

4TH EDITION

BASIC COLLEGE MATHEMATICS

A REAL-WORLD APPROACH

IGNACIO BELLO



 connect
| MATHEMATICS

This page intentionally left blank

Bello Basic College Mathematics

How to Use this Book: A Manual for Success

This brief guide shows you how to use the book effectively: Use It and Succeed!

It is as easy as 1, 2, 3.

BEGINNING OF THE SECTION

1. **To succeed:** Review the suggested topics at the beginning of each section
2. **Objectives:** Identify the tasks you should be able to perform (organized by section)
3. **Getting Started:** Preview the topics being discussed with a familiar application

EXAMPLES AND PAIRED MARGIN PROBLEMS

1. **Examples:** Explain, expand and help you attain the stated Objectives
2. **Green Math Examples:** Usually the last Example in each section deals with the environment
3. **Paired Margin Problems:** Reinforce skills in the Examples. (Answers at the bottom of page)

CHECK FOR MASTERY

1. **Concept Checker:** To reinforce key terms and get ready for the Mastery Test that follows
2. **Mastery Test:** Get a quick checkup to make sure you understand the material in the section
3. **Skill Checker:** Check in advance your understanding of the material in the next section

CONNECT WITH THE EXERCISES

1. **Connect:** Boost your grade with Connect Practice Problems, Self Tests, and Videos.
2. **Exercises (Grouped by Objectives):** Practice by doing! Interesting Applications included
3. **Green Applications:** Marked with a Green bar in the margin; math applied to the Environment

SUMMARY, REVIEW AND PRACTICE TEST

1. **Summary:** Easy-to-read grid details the items studied and their meaning and gives an Example
2. **Review:** Coded by Section number; do them and get extra reinforcement and practice!
3. **Practice Test:** Answers give Section, Example and Pages for easy reference to each question

EXTRA, EXTRA

1. **Cumulative Review:** Covers topics from present and prior chapters. Review all the material!
2. **Solutions Manual:** Worked out odd numbered solutions, all Reviews and Cumulative Reviews
3. **Videos on the Web:** Authors working problems from the Practice Test step by step

This page intentionally left blank

IGNACIO BELLO



BASIC COLLEGE

mathematics

A REAL-WORLD APPROACH

FOURTH EDITION

Ignacio Bello

Hillsborough Community College/University of South Florida





BASIC COLLEGE MATHEMATICS: A REAL-WORLD APPROACH, FOURTH EDITION

Published by McGraw-Hill, a business unit of The McGraw-Hill Companies, Inc., 1221 Avenue of the Americas, New York, NY 10020. Copyright © 2012 by The McGraw-Hill Companies, Inc. All rights reserved. Previous editions © 2009 and 2006. No part of this publication may be reproduced or distributed in any form or by any means, or stored in a database or retrieval system, without the prior written consent of The McGraw-Hill Companies, Inc., including, but not limited to, in any network or other electronic storage or transmission, or broadcast for distance learning.

Some ancillaries, including electronic and print components, may not be available to customers outside the United States.

 This book is printed on recycled, acid-free paper containing 10% postconsumer waste.

1 2 3 4 5 6 7 8 9 0 QDQ/QDQ 1 0 9 8 7 6 5 4 3 2 1

ISBN 978-0-07-338438-2

MHID 0-07-338438-0

ISBN 978-0-07-734330-9 (Annotated Instructor's Edition)

MHID 0-07-734330-1

Vice President, Editor-in-Chief: *Marty Lange*

Vice President, EDP: *Kimberly Meriwether David*

Senior Director of Development: *Kristine Tibbetts*

Editorial Director: *Stewart K. Mattson*

Sponsoring Editor: *Mary Ellen Rahn*

Developmental Editor: *Adam Fischer*

Marketing Manager: *Peter A. Vanaria*

Senior Project Manager: *Vicki Krug*

Buyer II: *Sherry L. Kane*

Senior Media Project Manager: *Sandra M. Schnee*

Senior Designer: *David W. Hash*

Cover Designer: *John Joran*

Cover Image: *Conga Drum on Tripod Stand*, © *Getty Images/Dorling Kindersley*, *View of Wall and Doorway*,

© *Getty Images/Grant Faint*

Senior Photo Research Coordinator: *Lori Hancock*

Photo Research: *David Tietz/Editorial Image, LLC*

Compositor: *MPS Limited, a Macmillan Company*

Typeface: *10/12 Times Roman*

Printer: *Quad/Graphics*

All credits appearing on page or at the end of the book are considered to be an extension of the copyright page.

Library of Congress Cataloging-in-Publication Data

Bello, Ignacio.

Basic college mathematics : a real-world approach / Ignacio Bello. — 4th ed.

p. cm.

Includes index.

ISBN 978-0-07-338438-2 — ISBN 0-07-338438-0 (hard copy : alk. paper) 1. Mathematics. I. Title.

QA39.3.B44 2012

510—dc22

2010020137

▶ About the Author



Bello

Ignacio Bello

attended the University of South Florida (USF), where he earned a B.A. and M.A. in Mathematics. He began teaching at USF in 1967, and in 1971 became a member of the Faculty at Hillsborough Community College (HCC) and Coordinator of the Math and Sciences Department. Professor Bello instituted the USF/HCC

remedial program, a program that started with 17 students taking Intermediate Algebra and grew to more than 800 students with courses covering Developmental English, Reading, and Mathematics. Aside from the present series of books (*Basic College Mathematics*, *Introductory Algebra*, and *Intermediate Algebra*), Professor Bello is the author of more than 40 textbooks including *Topics in Contemporary Mathematics* (ninth edition), *College Algebra*, *Algebra and Trigonometry*, and *Business Mathematics*. Many of these textbooks have been translated into Spanish. With Professor Fran Hopf, Bello started the Algebra Hotline, the only live, college-level television help program in Florida. Professor Bello is featured in three television programs on the award-winning Education Channel. He has helped create and develop the USF Mathematics Department Website (<http://mathcenter.usf.edu>), which serves as support for the Finite Math, College Algebra, Intermediate Algebra, and Introductory Algebra, and CLAST classes at USF. You can see Professor Bello's presentations and streaming videos at this website, as well as at <http://www.ibello.com>. Professor Bello is a member of the MAA and AMATYC and has given many presentations regarding the teaching of mathematics at the local, state, and national levels.

McGraw-Hill Connect

Less Managing.

More Teaching.

Greater Learning.

McGraw-Hill conducted in-depth research to create a new learning experience that meets the needs of students and instructors today. The result is a reinvented learning experience rich in information, visually engaging, and easily accessible to both instructors and students.

McGraw-Hill's Connect is a web-based assignment and assessment platform that helps students connect to their coursework and prepares them to succeed in and beyond the course.

Connect enables math and statistics instructors to create and share courses and assignments with colleagues and adjuncts with only a few clicks of the mouse. All exercises, learning objectives, and activities are directly tied to text-specific material.

McGraw-Hill has partnered with Blackboard Inc. to offer the deepest integration of digital content and tools with Blackboard's teaching and learning platform.



How was McGraw-Hill's Connect better developed than other sites in the market?

McGraw-Hill's Connect was developed with the instructor's needs in mind. Instructors with subject matter expertise in their respective course area worked with our vendors to build content that is accurate, maintains the intent of the original problem from the text, and is consistent with our authors' teaching methods.

Simple User Interface

Connect offers a variety of problem types with easy to use interface for students to input answers and receive various levels of feedback and help.

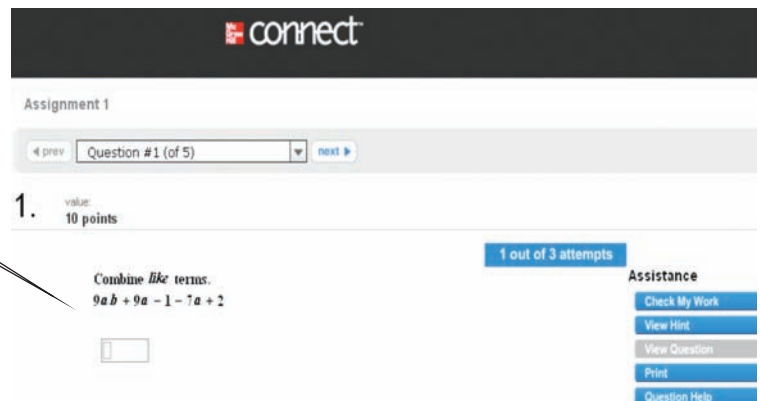

Simple Assignment Management

Connect allows instructors to quickly and easily build and organize assignments utilizing various sorting features for questions.

The screenshot shows the 'add questions' interface. On the left, there is a sidebar with filters: 'question type' (Answer Palette, Multiple Choice, Fill in the Blank, Chem/Physics/Eng Question, Multipart Answer, show all), 'Difficulty', 'Gradable', 'Learning Objective', 'Section', and 'Chapter'. The main area shows 'questions from... Chap. 4 - Polynomials > Sec. 4.02: Multiplication of Polynomials'. It lists 75 questions with checkboxes for selection and a 'question type' column. Questions include 'Example 1 - 4.2 Example 1' through 'Example 7 - 4.2 Example 7'.

Grade Reporting

The screenshot shows the 'assignment results' page. It includes a 'report type' dropdown set to 'Assignment Results'. Below, there are options for 'highlight ranges' (0-59%, 60-75%, 76-100%, all ranges, no ranges) and an 'export to excel' button. A table displays student performance:

Student	Pretest - Learning Chapter	Week Four - Learning	Summarize how memories are retrieved	Describe classical conditioning
Bickar, Wilson	100%	100%	85.71%	91.67%
Oberhuber, Ava	50%	66.67%	85.71%	100%
Dorn, Phoebe	100%	33.33%	28.57%	33.33%

View scored work immediately and track individual or group performance with various assignment and grade reports

Media-rich eBooks

Connect reinvents the textbook learning experience for the modern student. Each subject area is seamlessly integrated with ConnectPlus eBooks, which are designed to keep students focused on the concepts key to their success.

The screenshot shows a page titled 'chapter 1. Whole Numbers' with a sub-section '1.7 Primes, Factors, and Exponents'. It lists objectives and includes a 'Getting Started' section with a grid of numbers. Below that, there is a section for 'Primes and Composites' with a definition and examples.

▶ From the Author

The Inspiration for My Teaching

I was born in Havana, Cuba, and I encountered some of the same challenges in mathematics that many of my current students face, all while attempting to overcome a language barrier. In high school, I failed my freshman math course, which at the time was a complex language for me. However, with hard work and perseverance, I scored 100% on the final exam the second time around. While juggling various jobs in high school (roofer, sheetrock installer, and dock worker), I graduated and received a college academic scholarship. I first enrolled in calculus and made a “C.” Never one to be discouraged, I became a math major and worked hard to excel in the courses that had previously frustrated me.

While a graduate student at the University of South Florida (USF), I taught at a technical school, Tampa Technical Institute, a decision that contributed to my resolve to teach math and make it come alive for my students the way brilliant instructors such as Jack Britton, Donald Rose, and Frank Cleaver had done for me. My math instructors instilled in me the motivation to work toward success. Through my teaching, I have learned a great deal about the way in which students learn and how the proper guidance through the developmental mathematics curriculum leads to student success. I believe I have developed a strong level of guidance in my textbook series by carefully explaining the language of mathematics and providing my students with the key fundamentals to help them reach success.

A Lively Approach to Build Students’ Confidence

Teaching math at the University of South Florida was a great new career for me, but I found that students, professors, including myself, and administrators were disappointed by the rather imposing, mathematically correct but boring book we had to use. So, I took the challenge to write a book on my own, a book that was not only mathematically correct, but **student-oriented** with **interesting applications**—many suggested by the students themselves—and even, dare we say, entertaining! That book’s approach and philosophy proved an instant success and was a precursor to my current series.

Students fondly called my class “The Bello Comedy Hour,” but they worked hard, and they performed well. When my students ranked among the highest on the common final exam at USF, I knew I had found a way to motivate them through **common-sense language** and humorous, **realistic math applications**. I also wanted to show students they could overcome the same obstacles I had in math and become successful, too. If math has been a subject that some of your students have never felt comfortable with, then they’re not alone! This book was written with the **mathanxious** students in mind, so they’ll find it contains a jovial tone and explanations that are patient instead of making math seem mysterious, it makes it down-to-earth and easily digestible. For example, after explaining the different methods for simplifying fractions, readers are asked: “Which way should you simplify fractions? The way you understand!” Once students realize that math is within their grasp and not a foreign language, they’ll be surprised at how much more confident they feel.

A Real-World Approach: Applications, Student Motivation, and Problem Solving

What is a “real-world approach”? I found that most textbooks put forth “real-world” applications that meant nothing to the real world of my students. How many of my students would really need to calculate the speed of a bullet (unless they are in its

way) or cared to know when two trains traveling in different directions would pass by each other (disaster will certainly occur if they are on the same track)? For my students, both traditional and nontraditional, the real world consists of questions such as, “How do I find the best cell phone plan?” and “How will I pay my tuition and fees if they increase by $x\%$?” That is why I introduce mathematical concepts through everyday applications with **real data** and give homework using similar, well-grounded situations (see the Getting Started application that introduces every section’s topic and the word problems in every exercise section). Putting math in a real-world context has helped me overcome one of the problems we all face as math educators: **student motivation**. Seeing math in the real world makes students perk up in a math class in a way I have never seen before, and realism has proven to be the best motivator I’ve ever used. In addition, the real-world approach has enabled me to enhance students’ **problem-solving skills** because they are far more likely to tackle a real-world problem that matters to them than one that seems contrived.

Diverse Students and Multiple Learning Styles

We know we live in a pluralistic society, so how do you write one textbook for everyone? The answer is to build a flexible set of teaching tools that instructors and students can adapt to their own situations. Are any of your students members of a **cultural minority**? So am I! Did they learn **English as a second language**? So did I! You’ll find my book speaks directly to them in a way that no other book ever has, and fuzzy explanations in other books will be clear and comprehensible in mine.

Do your students all have the same **learning style**? Of course not! That’s why I wrote a book that will help students learn mathematics regardless of their personal learning style. **Visual learners** will benefit from the text’s clean page layout, careful use of color highlighting, “*Web Its*,” and the video lectures on the text’s website. **Auditory learners** will profit from the audio *e-Professor lectures* on the text’s website, and both **auditory** and **social learners** will be aided by the *Collaborative Learning* projects. **Applied** and **pragmatic learners** will find a bonanza of features geared to help them: *Pretests* can be found in MathZone providing practice problems by every example, and *Mastery Tests* appearing at the end of every section, to name just a few. **Spatial learners** will find the chapter *Summary* is designed especially for them, while **creative learners** will find the *Research Questions* to be a natural fit. Finally, **conceptual learners** will feel at home with features like “*The Human Side of Mathematics*” and the “*Write On*” exercises. Every student who is accustomed to opening a math book and feeling like they’ve run into a brick wall will find in my books that a number of doors are standing open and inviting them inside.

Listening to Student and Instructor Concerns

McGraw-Hill has given me a wonderful resource for making my textbook more responsive to the immediate concerns of students and faculty. In addition to sending my manuscript out for review by instructors at many different colleges, several times a year McGraw-Hill holds symposia and focus groups with math instructors where the emphasis is *not* on selling products but instead on the **publisher listening** to the needs of faculty and their students. These encounters have provided me with a wealth of ideas on how to improve my chapter organization, make the page layout of my books more readable, and fine-tune exercises in every chapter so that students and faculty will feel comfortable using my book because it incorporates their specific suggestions and anticipates their needs.

R-I-S-E to Success in Math

Why are some students more successful in math than others? Often it is because they know how to manage their time and have a plan for action. Students can use models similar to these tables to make a weekly schedule of their time (classes, study, work, personal, etc.) and a semester calendar indicating major course events like tests, papers, and so on. Have them try to do as many of the suggestions on the “**R-I-S-E**” list as possible. (Larger, printable versions of these tables can be found in MathZone at www.mhhe.com/bello.)

Weekly Time Schedule

Time	S	M	T	W	R	F	S
8:00							
9:00							
10:00							
11:00							
12:00							
1:00							
2:00							
3:00							
4:00							
5:00							
6:00							
7:00							
8:00							
9:00							
10:00							
11:00							

Semester Calendar

Wk	M	T	W	R	F
1					
2					
3					
4					
5					
6					
7					
8					
9					
10					
11					
12					
13					
14					
15					
16					

R—Read and/or view the material before and after each class. This includes the textbook, the videos that come with the book, and any special material given to you by your instructor.

I—Interact and/or practice using the CD that comes with the book or the Web exercises suggested in the sections, or seeking tutoring from your school.

S—Study and/or discuss your homework and class notes with a study partner/group, with your instructor, or on a discussion board if available.

E—Evaluate your progress by checking the odd numbered homework questions with the answer key in the back of the book, using the mastery questions in each section of the book as a selftest, and using the Chapter Reviews and Chapter Practice Tests as practice before taking the actual test.

As the items on this list become part of your regular study habits, you will be ready to “**R-I-S-E**” to success in math.

▶ Are you in need of relevant real-world applications? If so, look no further!

GREEN MATH

EXAMPLE 7 Water usage per day

How much water do you use each day? The average American uses as much as 101 gallons each day! The graph shows the water consumption at several locations in the home.

- In what location is the most water used?
- How many gallons per day are used in that location?
- What fraction of the total water is used in that location?

SOLUTION 7

- Toilet (shown gold)
- 27 gallons
- $\frac{27}{101}$

You can save between 3 and 5 gallons of water by cutting your shower short by one minute or flushing your toilet unnecessarily.

PROBLEM 7

- In what location is the least water used?
- How many gallons per day are used in that location?
- What fraction of the total water is used in that location?

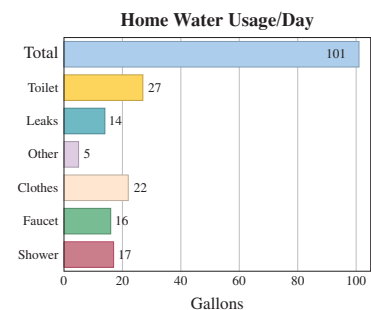

▶ New to this edition of Bello, *Basic College Mathematics*

Green Math Applications

We are learning more about the positive and negative impact we can have on the Earth’s fragile environment daily. It is everyone’s responsibility to help sustain our environment and the best way to get people involved is through awareness and education. The purpose of Green Math Applications is to provide students with the ability to apply mathematics to topics present in all aspects of their lives. Every day people see media reports about the environment, fill their car’s tank with gasoline, and make choices about what products they purchase. Green Math Applications teach students how to make and interpret these choices mathematically. Students will understand what it means when they read that this book was printed on paper that is 10% post consumer waste.

“The ‘Green Math’ applications are a great addition to the text. They answer the question that students always ask “But where will we ever use this stuff?”—Jan Butler, Colorado Community Colleges Online

▶ Preface

▶ Improvements in the Fourth Edition

General

- Unique to this edition and to the Bello mathematics series is the innovative Real-World Approach, Green Math Applications. New to this text are 59 examples and 224 exercises utilizing this new feature.
- Due to the evolution of our users, the Algebra Bridge feature has been removed from this edition.

Chapter 1

- Headers were added to application problems to clarify their objective.
- A new diagram was created to better illustrate the steps involved in Order of Operation problems.
- The rules for solving equations are now labeled as both Principles and Properties.
- Location of Divisibility of 4, 6, 8, 9, and 10 is now provided.

Chapter 2

- Clarified the definition of Equivalent Fractions.
- Added the objective and the coverage of the objective “Solve applications involving LCD” to Section 2.4.
- Changed Getting Starting and Using Your Knowledge in Section 2.6 to a more relevant topic for the students.
- Added a section part to Example 4.
- Clarified the steps in the Order of Operations found in Section 2.7.
- Area of a rectangle, Fundamental Properties of Fractions, and reducing to lowest terms were added to the Chapter Summary.

Chapter 3

- Added detail clarifying the steps involved in Order of Operations.
- Clarified the writing in the text and exercise sets.

Chapter 4

- The emphasis of Section 4.4 is Problem Solving Involving Proportions.
- Revised the definition of Ratio.
- Revised the definition of Ratio Notation.
- Revised the definition of Rates.
- New Getting Started in Section 4.4 connects the material to Section 4.3.
- Revised Chapter 4 Summary.

Chapter 5

- Updated the non–Green Math applications to reflect current data.
- Revised Chapter 5 Summary.

Chapter 6

- Updated the non–Green Math applications to reflect current data.
- Clarified the writing in the text and exercise sets.
- Updated the exercise sets to reflect more current data.

Chapter 7

- Clarified the writing in the text and exercise sets.
- Updated the exercise sets to reflect more current data.

Chapter 8

- Added more explanation regarding radius and diameter of a circle.
- Clarified the writing in the text and exercise sets.
- Updated the exercise sets to reflect more current data.

Chapter 9

- Revised the definition for Additive Inverse of a Number.
- Revised the definition for Dividends of Zero.
- Added Objective G: Solve applications involving rational numbers to Section 9.3.

Chapter 10

- Clarified the writing in the text and exercise sets.
- Added a note to clarify the use of signs in scientific notation.

Manuscript Review Panels

Teachers and academics from across the country reviewed the various drafts of the manuscript to give feedback on content, design, pedagogy, and organization. This feedback was summarized by the book team and used to guide the direction of the text.

Dr. Mohammed Abella, *Washtenaw Community College*
Harold Arnett, *Highland Community College*
Jean Ashby, *The Community College of Baltimore County*
Michelle Bach, *Kansas City Kansas Community College*
Mark Batell, *Washtenaw Community College*
Randy Burnette, *Tallahassee Community College*
Jan Butler, *Colorado Community Colleges Online*
Edie Carter, *Amarillo College*
Kris Chatas, *Washtenaw Community College*
Amtul Chaudry, *Rio Hondo College*
David DelRossi, *Tallahassee Community College*
Ginny Durham, *Gadsden State Community College*
Kristy Erickson, *Cecil College*
Brandi Faulkner, *Tallahassee Community College*
Angela Gallant, *Inver Hills Community College*
Matthew Gardner, *North Hennepin Community College*
Jane Golden, *Hillsborough Community College*
Lori Grady, *University of Wisconsin–Whitewater*
Jane Gringauz, *Minneapolis Community and Technical College*
Jennie Gurley, *Wallace State Community College–Hanceville*
Lawrence Hahn, *Luzerne County Community College*
Kristen Hathcock, *Barton Community College*
Mary Beth Headlee, *State College of Florida*
Rick Hobbs, *Mission College*
Linda Horner, *Columbia State Community College*
Kevin Hulke, *Chippewa Valley Technical College*
Nancy Johnson, *State College of Florida*
Linda Joyce, *Tulsa Community College*
John Keating, *Massasoit Community College*
Regina Keller, *Suffolk County Community College*
Charyl Link, *Kansas City Kansas Community College*
Debra Loeffler, *The Community College of Baltimore*

Annette Magyar, *Southwestern Michigan College*
Stan Mattoon, *Merced Community College*
Sherry McClain, *College of Central Florida*
Chris McNally, *Tallahassee Community College*
Allan Newhart, *West Virginia University–Parkersburg*
Charles Odion, *Houston Community College*
Laura Perez, *Washtenaw Community College*
Tammy Potter, *Gadsden State Community College*
Linda Prawdzik, *Luzerne County Community College*
Brooke Quinlan, *Hillsborough Community College*
Linda Reist, *Macomb Community College*
Nancy Ressler, *Oakton Community College*
Pat Rhodes, *Treasure Valley Community College*
Neal Rogers, *Santa Ana College*
Lisa Rombes, *Washtenaw Community College*
Nancy Sattler, *Terra Community College*
Joel Sheldon, *Santa Ana College*
Lisa Sheppard, *Lorain County Community College*
James Smith, *Columbia State Community College*
Linda Tremer, *Three Rivers Community College*
Dr. Miguel Uchofen, *Kansas City Kansas Community College*
Sara Van Asten, *North Hennepin Community College*
Alexsis Venter, *Arapahoe Community College*
Josefino Villanueva, *Florida Memorial University*
Ursula Walsh, *Minneapolis Community and Technical College*
Angela Wang, *Santa Ana College*
John Waters, *State College of Florida*
Karen White, *Amarillo College*
Jill Wilsey, *Genesee Community College*
Carol Zavarella, *Hillsborough Community College*
Vivian Zimmerman, *Prairie State College*
Loris Zucca, *Lone Star College–Kingwood*

I would like to thank the following people for their invaluable help:

Randy Welch, with his excellent sense of humor, organization, and very hard work; Dr. Tom Porter, of Photos at Your Place, who improved on some of the pictures I provided; Vicki Krug, one of the most exacting persons at McGraw-Hill, who will always give you the time of day and then solve the problem; Adam Fisher, our developmental editor, great with the numbers, professional, and always ready to help, Josie Rinaldo, who read a lot of the material for content overnight and Pat Steele, our very able copy editor. Finally, thanks to our attack secretary, Beverly DeVine, who still managed to send all materials back to the publisher on time. To everyone, my many thanks.

▶ Guided Tour

▶ Features and Supplements

Motivation for a Diverse Student Audience

A number of features exist in every chapter to motivate students' interest in the topic and thereby increase their performance in the course:

▶ The Human Side of Mathematics

To personalize the subject of mathematics, the origins of numerical notation, concepts, and methods are introduced through the lives of real people solving ordinary problems.



The Human Side of Mathematics

Here is a quiz for you: name one country that uses the metric system. Almost any country will do *except* the United States. Take a romantic vacation in France. It is a cool day; so you take a 30-minute walk to a nearby village, get some cheese and some wine. The temperature (in degrees Celsius, not Fahrenheit), the distance (kilometers, not miles), the cheese (kilograms, not pounds), and the wine (liters, not quarts) are all in the metric system. How did this happen?

Weights and measures are among the earliest tools invented by humans. Babylonians and Egyptians measured length with the forearm, hand, or finger, but the system used in the United States is based on the English system. The need for a single, worldwide, coordinated system of measurement was recognized over 300 years ago by Gabriel Mouton, vicar of St. Paul's Church in Lyon, France. In 1790, the National Assembly of France requested the French Academy of Sciences to "deduce an invariable standard for all measures and weights." The result was the metric system, made compulsory in France in 1840. What about the United States? As early as 1789, Thomas Jefferson submitted a report proposing a decimal-based system of measurement. Congress took no action on his proposal, but later, in 1832, he directed the Treasury Department to standardize the measures used by customs officials at U.S. ports. Congress allowed this report to stand without taking any formal action. Finally, in 1866, Congress legalized the use of the metric system and in 1875, the United States became one of the original signers of the Treaty of the Meter.

▶ Getting Started

Each topic is introduced in a setting familiar to students' daily lives, making the subject personally relevant and more easily understood.

▶ Getting Started

The sign on the left shows the price of 1 gallon of gasoline using the fraction, $\frac{9}{10}$. However, the sign on the right shows this price as the decimal 0.9. If we are given a



fraction, we can sometimes find its decimal equivalent by multiplying the numerator and denominator by a number that will cause the denominator to be a power of 10 (10, 100, 1000, etc.) and then writing the decimal equivalent. For example,

$$\frac{2}{5} = \frac{2 \cdot 2}{5 \cdot 2} = \frac{4}{10} = 0.4$$

$$\frac{3}{4} = \frac{3 \cdot 25}{4 \cdot 25} = \frac{75}{100} = 0.75$$

$$\frac{3}{125} = \frac{3 \cdot 8}{125 \cdot 8} = \frac{24}{1000} = 0.024$$

▶ Web It

Appearing in the margin of the section exercises, this URL refers students to the abundance of resources available on the Web that can show them fun, alternative explanations, and demonstrations of important topics.

Exercises 1.1

[connect](#)
MATHEMATICS

[Practice Problems](#) [Self-Tests](#)
[Media-rich eBooks](#) [e-Professors](#) [Videos](#)

▶ **A** **Place Value** In Problems 1–6, what is the value of the circled number?

States with most registered boats

Source: Data from National Marine Manufacturers Association.

5. 853,408

6. 853,048

▶ Web IT go to mhhe.com/bello for more lessons

▶ Write On

Writing exercises give students the opportunity to express mathematical concepts and procedures in their own words, thereby expressing and verbalizing what they have learned.

▶▶▶ Write On

52. What are the three variables (factors) used when calculating simple interest?

54. Which investment is better for you: \$10,000 invested at 5% compounded semiannually or \$10,000 invested at 4% compounded monthly. Explain why.

53. Write in your own words which would be better for you: to take a 20% discount on an item, or to take 10% off and then 10% off the reduced price.

55. Most people give 10%, 15%, or 20% of the total bill as a tip. (See Problem 42.)

a. In your own words, give a rule to find 10% of any amount. (*Hint:* It is a matter of moving the decimal point.)

b. Based on the rule in part a, state a rule that can be used to find 15% of any amount.

c. Based on the rule in part a, state a rule that can be used to find 20% of any amount.

▶ Collaborative Learning

Concluding the chapter are exercises for collaborative learning that promote teamwork by students on interesting and enjoyable exploration projects.

▶ Collaborative Learning

Planets	Time of Revolution Around the Sun	Weight	Multiplier	Factor
Mercury	88 days	Earth weight	×	0.38
Venus	224.7 days	Earth weight	×	0.91
Earth	365.25 days	Earth weight	×	1.00
Mars	687 days	Earth weight	×	0.38
Jupiter	11.86 years	Earth weight	×	2.60
Saturn	29.46 years	Earth weight	×	1.10
Uranus	84.01 years	Earth weight	×	0.90
Neptune	164.8 years	Earth weight	×	1.20
Pluto*	248.5 years	Earth weight	×	0.08

* Pluto is not classified as a planet at this time.

Suppose you want to become younger (in age) and trimmer (in weight). We can help you with that, but it will require a little travel. Let us start with the age issue. On Earth, a year is 365 days long but the year on other planets is dependent on the distance the planet is away from the sun. The first table shows the time it takes each of the planets to go around the sun. Now, suppose you are 18 years old. What is your Mercurian age? Since Mercury goes around the sun every 88 days, you would be much older! (You have been around more!) As a matter of fact your Mercurian age M would be $M = 18 \times \frac{365}{88} \approx 75$ years old.

In which planet will you become youngest? We will let you find out for yourself. *Hint:* The denominator has to be in days, for example, 88 days.

Now, for the weight issue. Suppose you weigh 130 pounds on Earth. How much would you weigh on Mercury? Since your weight is dependent on the laws of gravity of the planet you are visiting, your weight will change by the factor shown in the second table.

On Mercury, your weight would be: $130 \times 0.38 \approx 49$ pounds.

▶ Guided Tour

▶ Research Questions

Research questions provide students with additional opportunities to explore interesting areas of math, where they may find the questions can lead to surprising results.

▶ Research Questions

1. Where did the decimal point first appear, in what year, and who used the decimal point?
2. Write a brief description of the decimal system we use, how it works, and how decimals are used.
Reference: <http://www.infoplease.com>
3. Write a brief description of the Dewey decimal system, how it works, and for what it is used.
Reference: <http://www.mtsu.edu>
4. Write a paragraph about Bartholomeus Pitiscus and the ways in which he used the decimal point.
5. Write a paragraph explaining where our decimal system comes from and its evolution throughout the years.
Reference: <http://www.scit.wlv.ac.uk>

Abundant Practice and Problem Solving

Bello offers students many opportunities and different skill paths for developing their problem-solving skills.

▶ Paired Examples/ Problems

Examples are placed adjacent to similar problems intended for students to obtain immediate reinforcement of the skill they have just observed. These are especially effective for students who learn by doing and who benefit from frequent practice of important methods. Answers to the problems appear at the bottom of the page.

GREEN MATH

EXAMPLE 5 Windows and insulation

The return on investment ($ROI = \frac{\text{savings}}{\text{added cost}}$) when you install Energy Star windows is 0.43. (See Example 8, Section 3.3.) If you insulate your basement walls, your added cost is \$750 and your annual electricity savings are \$300.

- a. What is your ROI written as a reduced fraction?
- b. Compare 0.43 and the ROI from part a.
- c. Which is the better ROI, new windows or insulating the basement walls?

SOLUTION 5

- a. $\frac{300}{750} = \frac{2}{5}$
- b. We have to compare 0.43 and $\frac{2}{5}$. Convert $\frac{2}{5}$ to a decimal by dividing 2 by 5, obtaining 0.40. Now it is easy to compare $\frac{2}{5} = 0.40$ and 0.43; 0.43 is larger.
- c. The ROI when you install new windows (0.43) is better than insulating your basement walls (0.40).

PROBLEM 5

If you increase the insulation of your heating/AC ducts, the savings are \$180 at a cost of \$450.

- a. What is the ROI written as a reduced fraction?
- b. Compare the ROI of insulating your heating/AC ducts with the insulation of your basement walls (0.40).
- c. Which is the better ROI, insulating your heating/AC ducts or insulating your basement walls?

Answers to PROBLEMS

5. a. $\frac{2}{5}$ b. $\frac{2}{5}$ and 0.40 are the same c. Neither, they are both the same, 0.40

▶ RSTUV Method

The easy-to-remember “RSTUV” method gives students a reliable and helpful tool in demystifying word problems so that they can more readily translate them into equations they can recognize and solve.

- Read the problem and decide what is being asked.
- Select a letter or \square to represent this unknown.
- Translate the problem into an equation.
- Use the rules you have studied to solve the resulting equation.
- Verify the answer.

RSTUV PROCEDURE TO SOLVE WORD PROBLEMS

1. Read the problem carefully and decide what is asked for (the unknown).
2. Select \square or a letter to represent the unknown.
3. Translate the problem into an equation.
4. Use the rules we have studied to solve the equation.
5. Verify the answer.

TRANSLATE THIS

1. The average cost for tuition and fees at a 2-year public college is \$2191. This represents a 5.4% increase from last year's cost L .

Source: www.CollegeBoard.com.

2. The average 2-year public college student receives grant aid (G) that reduces the average tuition and fees of \$2191 to a net price of \$400.

Source: www.CollegeBoard.com.

3. According to the Census Bureau a person with a bachelor's degree earns 62% more on average than those with only a high school diploma. If a person with a high school diploma makes h dollars a year, what is the pay b for a person with a bachelor's degree?

Source: www.CollegeBoard.com.

4. At 2-year public institutions, the average tuition and fees is \$2191, which is \$112 more than last year's cost L . What was the cost of tuition and fees last year?

Source: www.CollegeBoard.com.

5. At American University, the cost per credit for undergraduate courses is \$918. What is the cost C for an undergraduate taking h credits?

Source: American University.

The third step in the RSTUV procedure is to **TRANSLATE** the information into an equation. In Problems 1–10 **TRANSLATE** the sentence and match the correct translation with one of the equations A–O.

- A. $T + 3.8 = 103.8$
- B. $2191 - G = 400$
- C. $P = 39 + 0.45m$
- D. $D = 10,9391P$
- E. $2191 = L + 5.4\%L$
- F. $h = b + 62\%h$
- G. $C = 13.75h$
- H. $C = 918h$
- I. $G - 2191 = 400$
- J. $h = b + 62\%h$
- K. $C = 51W$
- L. $P = 10,9391D$
- M. $W = 51C$
- N. $2191 = L + 112$
- O. $D = 10,9391P$

6. The monthly access fee for a cell phone plan is \$39 plus \$0.45 for each minute after a 300-minute allowance. If Joey used m minutes over 300, write an equation for the amount P Joey paid.
7. If the body temperature T of a penguin were 3.8°F warmer, it would be as warm as a goat, 103.8°F .
8. The Urban Mobility Institute reports that commuters say they would be willing to pay \$13.75 an hour to avoid traffic congestion. What would be the cost C for h hours of avoiding traffic congestion?
9. Since the price of gas is higher, commuters are willing to pay more than \$13.75 an hour to avoid traffic congestion, say W dollars per hour. South Florida travelers lose 51 hours per year due to traffic congestion. Write an equation that will give the total cost C for Florida travelers to avoid losing any time to traffic congestion.
10. As of this writing, one U.S. dollar is worth 10,9391 Mexican pesos. Write the formula to convert D dollars to P Mexican pesos.

▶ Translate This

These boxes appear periodically before word-problem exercises to help students translate phrases into equations, reinforcing the RSTUV method.

› Exercises

A wealth of exercises for each section are organized according to the learning objectives for that section, giving students a reference to study if they need extra help.

› Exercises 1.6

[Practice Problems](#) > [Self-Tests](#)
[Media-rich eBooks](#) > [e-Professors](#) > [Videos](#)

< A > Writing Division as Multiplication

In Problems 1–20, divide and check using multiplication.

1. $30 \div 5$	2. $63 \div 9$	3. $28 \div 4$	4. $6 \div 1$
5. $21 \div 7$	6. $2 \div 0$	7. $0 \div 2$	8. $54 \div 9$
9. $7 \div 7$	10. $56 \div 8$	11. $\frac{36}{9}$	12. $54 \div 6$
13. $\frac{3}{0}$	14. $\frac{0}{3}$	15. $\frac{32}{8}$	16. $\frac{13}{13}$
17. $\frac{24}{1}$	18. $\frac{45}{9}$	19. $\frac{62}{6}$	20. $\frac{48}{5}$

“Applications have a greater percentage of problems from any section when compared to the skill and drill (problems objective by objective). They are current and applicable, especially 5.6 Consumer Credit. An excellent section for college students. Should be an assignment for student orientation!”—Chris McNally, Tallahassee Community College

› Applications

Students will enjoy the exceptionally creative applications in most sections that bring math alive and demonstrate that it can even be performed with a sense of humor.

››› Applications: Green Math

Converting sunshine into electricity by using solar panels will actually cost you more than burning fossil fuels, but there is hope. Grants and tax incentives are available to make the process more cost effective. To read more about this go to <http://tinyurl.com/ck8n62>.

Area and cost of solar panels. In Problems 97–100, find the **area** of the panel. The approximate cost of each panel is given in parentheses (prices vary).

97. 60-watt panel, 27 inches by $30\frac{3}{8}$ inches. (\$350)

98. 50-watt panel, 28 inches by $21\frac{7}{8}$ inches. (\$420)



Source: <http://www.solarhome.org/60wattframedsolarpanel.aspx>.



Source: <http://www.solarhome.org/acesolaroff-grid-solar-module-50et.aspx>.

› Using Your Knowledge

Optional, extended applications give students an opportunity to practice what they’ve learned in a multistep problem requiring reasoning skills in addition to numerical operations.

››› Using Your Knowledge

Orbital times The table showing the approximate orbital time for Mars, Jupiter, Saturn, and Uranus will be used in Problems 51–53.

	Mars	Jupiter	Saturn	Uranus
Orbital period (Earth years)	2	12	30	84

51. You remember the planet alignment from the Getting Started? As you can see from the table it takes about 12 years for Jupiter to orbit around the sun once but it takes Saturn 30 years to do so. If Mars takes about 2 years to orbit the sun and the last planetary alignment of Jupiter, Mars, and Saturn was in the year 2000, in what year will the alignment of the three planets happen again?
52. If Jupiter, Uranus, and Mars were aligned today, how many years would it take for them to align again?
53. If Saturn and Uranus were aligned today, how many years will it take for them to align again?

▶ Guided Tour

Study Aids to Make Math Accessible

Because some students confront math anxiety as soon as they sign up for the course, the Bello system provides many study aids to make their learning easier.

▶ Objectives

The objectives for each section not only identify the specific tasks students should be able to perform, they organize the section itself with letters corresponding to each section heading, making it easy to follow.

3.4 Decimals, Fractions, and Order of Operations

▶ Objectives

You should be able to:

A > Compare two or more decimals and determine which is larger.

B > Compare fractions and decimals and determine which is larger.

C > Solve applications involving fractions, decimals, and the order of operations.

▶ To Succeed, Review How To . . .

- Write a fraction as a decimal. (pp. 223–225)
- Divide a decimal by a whole number. (p. 216)
- Understand the meaning of and notation for pure repeating decimals. (p. 226)
- Work with the order of operations. (pp. 82–84)

▶ Getting Started

Which of the two Pepsi offers is better? To answer this question, we can find the price of each can by dividing \$2.00 by 8 and \$2.99 by 12 and then comparing the individual price of each can.

0.25	0.24
8 2.00	12 2.99
16	24
40	59
40	48
0	11

▶ Reviews

Every section begins with “To succeed, review how to . . .,” which directs students to specific pages to study key topics they need to understand to successfully begin that section.

▶ Concept Checker

This feature has been added to the end-of-section exercises to help students reinforce key terms and concepts.

▶▶▶ Concept Checker

Fill in the blank(s) with the correct word(s), phrase, or mathematical statement.

- | | |
|--|--|
| <p>81. To convert a percent to a decimal, move the decimal point _____ places to the _____ and omit the % symbol.</p> <p>82. To convert a decimal to a percent, move the decimal point _____ places to the _____ and attach the % symbol.</p> <p>83. To convert a percent to a fraction, follow these steps:</p> <p style="margin-left: 20px;">a. Write the number over _____</p> <p style="margin-left: 20px;">b. _____ the resulting fraction</p> | <p>divide attach</p> <p>left reduce</p> <p>omit multiply</p> <p>two percent</p> <p>right fraction</p> <p>100 %</p> |
|--|--|

▶ Mastery Tests

Brief tests in every section give students a quick checkup to make sure they're ready to go on to the next topic.

▶▶▶ Mastery Test

- | | |
|--|--|
| <p>85. Among taxpayers who owed the IRS money, 82% said they would use money from their savings or checking accounts to pay their taxes. Write 82% as</p> <p style="margin-left: 20px;">a. a reduced fraction. b. a decimal.</p> <p>87. Write as a reduced fraction:</p> <p style="margin-left: 20px;">a. $6\frac{1}{2}\%$ b. 6.55%</p> | <p>86. Write as a percent:</p> <p style="margin-left: 20px;">a. $\frac{3}{8}$ b. $\frac{3}{5}$</p> <p>88. Write as a reduced fraction:</p> <p style="margin-left: 20px;">a. 19% b. 80%</p> |
|--|--|

▶ Skill Checkers

These brief exercises help students keep their math skills well honed in preparation for the next section.

▶▶▶ Skill Checker

In Problems 44–47, find:

- 44.** $\frac{1}{2}$ of 50 = **45.** $\frac{1}{2}$ of 100 = **46.** $3 \cdot 100 =$ **47.** $7 \cdot 100 =$

▶ Calculator Corner

When appropriate, optional calculator exercises are included to show students how they can explore concepts through calculators and verify their manual exercises with the aid of technology.

Calculator Corner

A calculator is very convenient when doing taxes, interest, commissions, and discounts. Let us take each of the problems separately. For example, to solve Example 1: Find how much you have to pay for a pair of pants costing \$18.50 if the tax is 6% by simply pressing $18.50 + 6 \%$ ENTER. The final answer, \$19.61, will be displayed.

If your calculator does not have a % key, you may have to use the **store** [M+] and **recall** [MR] keys. As their names imply, these keys *store* numbers in their memory and then *recall* them. Suppose you wish to solve Example 1 with a calculator. You press 18.50 [M+] 0.06 ENTER. Here the calculator has **stored** the 18.50 and taken 6% of 18.50. The display shows 1.11. Now, press $+$ [MR] ENTER and the calculator will add the number stored (18.50) to the 1.11, giving you \$19.61, as before.

If your calculator has a y^x key (a **power key**), then the quantity $(1.03)^6$ appearing in Example 4 can be obtained as follows: 1.03 y^x 6 ENTER. You will get 1.19405230.

▶ Summary

An easy-to-read grid summarizes the essential chapter information by section, providing an item, its meaning, and an example to help students connect concepts with their concrete occurrences.

▶ Summary Chapter 3			
Section	Item	Meaning	Example
3.1A	Word names	The word name for a number is the number written in words.	The word name for 4.7 is four and seven tenths.
3.1B	Expanded form	Numeral written as a sum indicating the value of each digit.	$78.2 = 70 + 8 + \frac{2}{10}$
3.2B	Multiplying by powers of 10	A product involving 10, 100, 1000, and so on as a factor.	$93.78 \times 100 = 9378$

“Great Review material. I like the fact that chapter tests at the end have the answers on the next page and corresponding pages for those problems students miss to go back and review the material.”—Vivian Zimmerman, Prairie State College.

▶ Review Exercises

Chapter review exercises are coded by section number and give students extra reinforcement and practice to boost their confidence.

▶ Review Exercises Chapter 3		
<i>(If you need help with these exercises, look in the section indicated in brackets.)</i>		
1. < 3.1A > Give the word name.	2. < 3.1B > Write in expanded form.	3. < 3.1C > Add.
a. 23.389	a. 37.4	a. $8.51 + 13.43$
b. 22.34	b. 59.09	b. $9.6457 + 15.78$
c. 24.564	c. 145.035	c. $5.773 + 18.0026$
	d. 150.309	d. $6.204 + 23.248$
	e. 234.003	e. $9.24 + 14.28$

▶ Practice Test with Answers

The chapter Practice Test offers students a nonthreatening way to review the material and determine whether they are ready to take a test given by their instructor. The answers to the Practice Test give students immediate feedback on their performance, and the answer grid gives them specific guidance on which section, example, and pages to review for any answers they may have missed.

▶ Practice Test Chapter 3	
<i>(Answers on page 252)</i>	
<i>Visit www.mhhe.com/bello to view helpful videos that provide step-by-step solutions to several of the problems below.</i>	
1. Give the word name for 342.85.	2. Write 24.278 in expanded form.
3. $9 + 12.18 = \underline{\hspace{2cm}}$	4. $46.654 + 8.69 = \underline{\hspace{2cm}}$
5. $447.42 - 18.5 = \underline{\hspace{2cm}}$	6. $5.34 \cdot 0.013 = \underline{\hspace{2cm}}$

▶ Answers to Practice Test Chapter 3				
Answer	If You Missed		Review	
	Question	Section	Examples	Page
1. Three hundred forty-two and eighty-five hundredths	1	3.1	1	201
2. $20 + 4 + \frac{2}{10} + \frac{7}{100} + \frac{8}{1000}$	2	3.1	2	202
3. 21.18	3	3.1	3	203
4. 55.344	4	3.1	4, 5	203–204

▶ Guided Tour

› Cumulative Review

The Cumulative Review covers material from the present chapter and any of the chapters prior to it and can be used for extra homework or for student review to improve their retention of important skills and concepts.

› Cumulative Review Chapters 1–3

1. Write $300 + 90 + 4$ in standard form.
2. Write three thousand, two hundred ten in standard form.
3. Write the prime factors of 20.
4. Write 60 as a product of primes.
5. Multiply: $2^2 \times 5 \times 5^0$
6. Simplify: $49 \div 7 \cdot 7 + 8 - 5$
7. Classify $\frac{5}{4}$ as proper or improper.
8. Write $\frac{11}{2}$ as a mixed number.
9. Write $5\frac{3}{8}$ as an improper fraction.
10. $\frac{2}{3} = \frac{?}{27}$
11. $\frac{5}{7} = \frac{25}{?}$
12. Multiply: $\frac{1}{2} \cdot 5\frac{1}{6}$

Supplements for Instructors

Annotated Instructor's Edition

This version of the student text contains **answers** to all odd- and even-numbered exercises in addition to helpful **teaching tips**. The answers are printed on the same page as the exercises themselves so that there is no need to consult a separate appendix or answer key.

Computerized Test Bank (CTB) Online

Available through McGraw-Hill Connect™ Mathematics, this **computerized test bank** utilizes Brownstone Diploma®, an algorithm-based testing software to quickly create customized exams. This user-friendly program enables instructors to search for questions by topic, format, or difficulty level; to edit existing questions or to add new ones; and to scramble questions and answer keys for multiple versions of the same test. Hundreds of text-specific open-ended and multiple-choice questions are included in the question bank. Sample chapter tests and final exams in Microsoft Word® and PDF formats are also provided.

Instructor's Solutions Manual

Available on McGraw-Hill Connect™ Mathematics, the Instructor's Solutions Manual provides comprehensive, **worked-out solutions** to all exercises in the text. The methods used to solve the problems in the manual are the same as those used to solve the examples in the textbook.



McGraw-Hill Connect™ Mathematics is a complete online tutorial and homework management system for mathematics and statistics, designed for greater ease of use than any other system available. Instructors have the flexibility to create and share courses and assignments with colleagues, adjunct faculty, and teaching assistants with only a few clicks of the mouse. All algorithmic exercises, online tutoring, and a variety of video and animations are directly tied to text-specific materials. Completely customizable, Connect Mathematics suits individual instructor and student needs. Exercises can be easily edited, multimedia is assignable, importing additional content is easy, and instructors can even control the level of help available to students while doing their homework. Students have the added benefit of full access to the study tools to individually improve their success without having to be part of a Connect Mathematics course. Connect Mathematics allows for automatic

grading and reporting of easy-to assign algorithmically generated homework, quizzes and tests. Grades are readily accessible through a fully integrated grade book that can be exported in one click to Microsoft Excel, WebCT, or BlackBoard.

Connect Mathematics Offers

- Practice exercises, based on the text's end-of-section material, generated in an unlimited number of variations, for as much practice as needed to master a particular topic.
- Subtitled videos demonstrating text-specific exercises and reinforcing important concepts within a given topic.
- Assessment capabilities, powered through ALEKS, which provide students and instructors with the diagnostics to offer a detailed knowledge base through advanced reporting and remediation tools.
- Faculty with the ability to create and share courses and assignments with colleagues and adjuncts, or to build a course from one of the provided course libraries.
- An Assignment Builder that provides the ability to select algorithmically generated exercises from any McGraw-Hill math textbook, edit content, as well as assign a variety of Connect Mathematics material including an ALEKS Assessment.
- Accessibility from multiple operating systems and Internet browsers.



ALEKS® (www.aleks.com)

ALEKS (Assessment and Learning in Knowledge Spaces) is a dynamic online learning system for mathematics education, available over the Web 24/7. ALEKS assesses students, accurately determines their knowledge, and then guides them to the material that they are most ready to learn. With a variety of reports, Textbook Integration Plus, quizzes, and homework assignment capabilities, ALEKS offers flexibility and ease of use for instructors.

- ALEKS uses artificial intelligence to determine exactly what each student knows and is ready to learn. ALEKS remediates student gaps and provides highly efficient learning and improved learning outcomes.
- ALEKS is a comprehensive curriculum that aligns with syllabi or specified textbooks. Used in conjunction with McGraw-Hill texts, students also receive links to text-specific videos, multimedia tutorials, and textbook pages.
- Textbook Integration Plus allows ALEKS to be automatically aligned with syllabi or specified McGraw-Hill textbooks with instructor chosen dates, chapter goals, homework, and quizzes.
- ALEKS with AI-2 gives instructors increased control over the scope and sequence of student learning. Students using ALEKS demonstrate a steadily increasing mastery of the content of the course.
- ALEKS offers a dynamic classroom management system that enables instructors to monitor and direct student progress toward mastery of course objectives.

Supplements for Students

Student's Solutions Manual

This supplement contains complete worked-out solutions to all odd-numbered exercises and all odd- and even-numbered problems in the Review Exercises and

▶ Guided Tour

Cumulative Reviews in the textbook. The methods used to solve the problems in the manual are the same as those used to solve the examples in the textbook. This tool can be an invaluable aid to students who want to check their work and improve their grades by comparing their own solutions to those found in the manual and finding specific areas where they can do better.



McGraw-Hill Connect Mathematics is a complete online tutorial and homework management system for mathematics and statistics, designed for greater ease of use than any other system available. All algorithmic exercises, online tutoring, and a variety of video and animations are directly tied to text-specific materials.

A screenshot of the McGraw-Hill Connect Mathematics interface showing 'Exercises 4.2'. The page has a purple header with the 'connect MATHEMATICS' logo and navigation links. Below the header, the title 'Exercises 4.2' is displayed. A vertical sidebar on the left contains the text 'Web IT go to mhhe.com/bello for more lessons'. The main content area is titled '< A > Writing Rates' and includes the instruction 'In Problems 1–10, write the indicated rates.' followed by ten numbered problems. Each problem is a word problem involving rates of pay, miles per gallon, plane speed, or production rates.

> Exercises 4.2

< A > Writing Rates In Problems 1–10, write the indicated rates.

1. *Rate of pay per hour* A student is paid at the rate of \$38 for 8 hours of work. What is the rate per hour?
2. *Construction worker's pay* According to the Bureau of Labor Statistics, the average construction worker makes \$760 a week and works 40 hours. What is the rate per hour?
3. *Calculating miles per gallon* A car uses 12 gallons of gas on a 258-mile trip. How many miles per gallon is that?
4. *Miles per gallon* A student traveled 231 miles in going from Houston to Dallas. If she used 12 gallons of gas, how many miles per gallon did her car get?
5. *Plane's rate of travel* A plane flew from Boston to Chicago in 1.5 hours. If the air distance between these two cities is 840 miles, what was the plane's rate of travel?
6. *Plane's rate of travel* The air distance between New York and Dallas is 1375 miles. If a plane takes $2\frac{1}{2}$ hours to make the flight, what is the plane's rate of travel?
7. *More flying* One of the fastest flights in the continental United States was made by Captain Robert G. Sowers. He flew 2459 miles from Los Angeles to New York in 2 hours. What was his rate of travel?
8. *Marathon runner* One of the fastest marathon runners is Balaine Desimo, who completed 26 miles in 2.1 hours. To the nearest mile, what was his rate of travel?
9. *Tortilla rate of consumption* Tom Nall ate 74 tortillas in 30 minutes at Mariano's Mexican Restaurant in Dallas, Texas. To the nearest tenth, what was his per-minute rate of consumption?
10. *Refinery rate of production* The Amerada Hess refinery in St. Croix produced 345,000 barrels of oil a day. What is the rate of production in barrels per hour?



ALEKS (Assessment and LEarning in Knowledge Spaces) is a dynamic online learning system for mathematics education, available over the Web 24/7. ALEKS assesses students, accurately determines their knowledge, and then guides them to the material that they are most ready to learn. With a variety of reports, Textbook Integration Plus, quizzes, and homework assignment capabilities, ALEKS offers flexibility and ease of use for instructors.

Bello Video Series

The video series is available online and features the authors introducing topics and working through selected odd-numbered exercises from the text, explaining how to complete them step by step. They are **closed-captioned** for the hearing impaired and are also **subtitled in Spanish**.

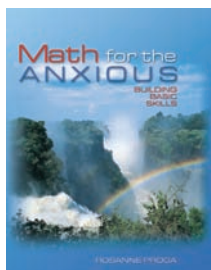

Math for the Anxious: Building Basic Skills, by Rosanne Proga

Math for the Anxious: Building Basic Skills is written to provide a practical approach to the problem of math anxiety. By combining strategies for success with a pain-free introduction to basic math content, students will overcome their anxiety and find greater success in their math courses.

Preface viii

Guided Tour: Features and Supplements xiv

Applications Index xxviii

Chapter
one

1



▶ Whole Numbers

The Human Side of Mathematics 1

- 1.1** Standard Numerals 2
- 1.2** Ordering and Rounding Whole Numbers 13
- 1.3** Addition 23
- 1.4** Subtraction 37
- 1.5** Multiplication 50
- 1.6** Division 63
- 1.7** Primes, Factors, and Exponents 72
- 1.8** Order of Operations and Grouping Symbols 83
- 1.9** Equations and Problem Solving 91

Collaborative Learning 102

Research Questions 103

Summary 103

Review Exercises 106

Practice Test 1 110

Chapter
two

2



▶ Fractions and Mixed Numbers

The Human Side of Mathematics 113

- 2.1** Fractions and Mixed Numbers 114
- 2.2** Equivalent Fractions: Building and Reducing 125
- 2.3** Multiplication and Division of Fractions and Mixed Numbers 134
- 2.4** The Least Common Multiple (LCM) 147
- 2.5** Addition and Subtraction of Fractions 157
- 2.6** Addition and Subtraction of Mixed Numbers 168
- 2.7** Order of Operations and Grouping Symbols 177
- 2.8** Equations and Problem Solving 186

Collaborative Learning 197

Research Questions 198

Summary 198

Review Exercises 200

Practice Test 2 205

Cumulative Review Chapters 1–2 207

Contents

Chapter *three*

3

▶ Decimals

Account Types	Annual Percentage Yield (APY)	Annual Interest Rate (AIR)
3 Month C/D	1.95	-
1 (\$100 Minimum Opening Deposit)	-	-
4 Month C/D	2.15	-
1 (\$100 Minimum Opening Deposit)	-	-
12 Month C/D	2.35	-
1 (\$100 Minimum Opening Deposit)	-	-
12 Month Club Savings	3.05	3.00
1 (\$100 Minimum Opening Deposit)	-	-
24 Month Club Savings	3.82	3.75
1 (\$100 Minimum Opening Deposit)	-	-
36 Month Club Savings	4.60	4.50
1 (\$100 Minimum Opening Deposit)	-	-
NOW	1.01	1.00
1 (\$100 Minimum Opening Deposit)	-	-
Money Market	1.26	1.25
1 (\$100 Minimum Opening Deposit)	-	-
Statement Savings	1.01	1.00
1 (\$100 Minimum Opening Deposit)	-	-
Investment Banking Account	0.00	0.00
Basic Checking Account	-	-

NOW: Money Market, Statement Savings and Flexible Savings Account rates are based on change in rates. NOW: Minimum balance \$100. Money Market: Minimum balance \$100. Statement Savings: Account balance \$100. All rates are subject to change without notice. Percentage Yield: Annual percentage yield (APY) is the rate of interest earned on an investment over a 12-month period. Annual Interest Rate (AIR) is the rate of interest earned on an investment over a 12-month period. All rates are subject to change without notice. Please contact Customer Service Desk for further information about applicable fees, charges and offers. [View Complete Annual Periodic Statement](#)

CHO HUNG BANK OF NEW YORK
Member FDIC

The Human Side of Mathematics 209

3.1 Addition and Subtraction of Decimals 210

3.2 Multiplication and Division of Decimals 221

3.3 Fractions and Decimals 234

3.4 Decimals, Fractions, and Order of Operations 243

3.5 Equations and Problem Solving 251

Collaborative Learning 258

Research Questions 259

Summary 259

Review Exercises 260

Practice Test 3 263

Cumulative Review Chapters 1–3 265

Chapter *four*

4

▶ Ratio, Rate, and Proportion



The Human Side of Mathematics 267

4.1 Ratio 268

4.2 Rates 274

4.3 Proportions 282

4.4 Problem Solving Involving Proportions 290

Collaborative Learning 297

Research Questions 298

Summary 298

Review Exercises 299

Practice Test 4 301

Cumulative Review Chapters 1–4 303

Chapter *five*

5

▶ Percent



The Human Side of Mathematics 305

5.1 Percent Notation 306

5.2 Percent Problems 316

5.3 Solving Percent Problems Using Proportions 328

5.4 Taxes, Interest, Commissions, and Discounts 333

5.5 Applications: Percent of Increase or Decrease 343

5.6 Consumer Credit 351

Collaborative Learning 361

Research Questions 361

Chapter
six

6

▶ Statistics and Graphs

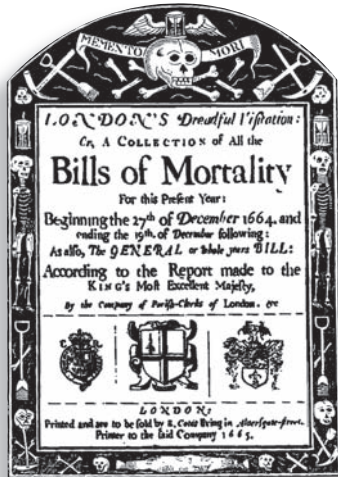

Summary 362
Review Exercises 363
Practice Test 5 367
Cumulative Review Chapters 1–5 369

The Human Side of Mathematics 371

6.1 Tables and Pictographs 372

6.2 Bar and Line Graphs 379

6.3 Circle Graphs (Pie Charts) 396

6.4 Mean, Median, and Mode 408

Collaborative Learning 419

Research Questions 419

Summary 420

Review Exercises 421

Practice Test 6 425

Cumulative Review Chapters 1–6 428

Chapter
seven

7

▶ Measurement and the Metric System



The Human Side of Mathematics 431

7.1 Length: U.S. System 432

7.2 Length: The Metric System 438

7.3 Length: U.S. to Metric and Metric to U.S. Conversions 444

7.4 Area: U.S., Metric, and Conversions 450

7.5 Volume (Capacity): U.S., Metric, and Conversions 455

7.6 Weight and Temperature: U.S., Metric, and Conversions 462

Collaborative Learning 469

Research Questions 470

Summary 470

Review Exercises 472

Practice Test 7 475

Cumulative Review Chapters 1–7 477

▶ Contents

Chapter
eight

8

▶ Geometry

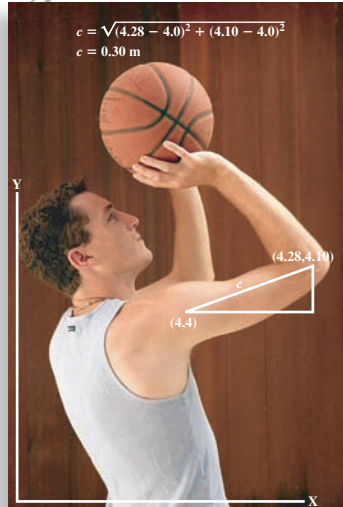

The Human Side of Mathematics 479

8.1 Lines, Angles, and Triangles 480

8.2 Finding Perimeters 498

8.3 Finding Areas 506

8.4 Volume of Solids 516

8.5 Square Roots and the Pythagorean Theorem 527

Collaborative Learning 535

Research Questions 536

Summary 536

Review Exercises 540

Practice Test 8 544

Cumulative Review Chapters 1–8 547

Chapter
nine

9

▶ The Real Numbers



The Human Side of Mathematics 549

9.1 Addition and Subtraction of Integers 550

9.2 Multiplication and Division of Integers 566

9.3 The Rational Numbers 575

9.4 Order of Operations 587

Collaborative Learning 595

Research Questions 595

Summary 596

Review Exercises 597

Practice Test 9 602

Cumulative Review Chapters 1–9 604

Chapter
ten

10

▶ Introduction to Algebra



The Human Side of Mathematics 607

10.1 Introduction to Algebra 608

10.2 The Algebra of Exponents 619

10.3 Scientific Notation 628

10.4 Solving Linear Equations 634

10.5 Applications: Word Problems 644

Collaborative Learning 657
Research Questions 658
Summary 658
Review Exercises 659
Practice Test 10 663
Cumulative Review Chapters 1–10 665

Selected Answers SA-1

Photo Credits C-1

Index I-1

► Applications Index

Animals

alligator teeth, 279
antelope speed, 437
bird sizes, 436, 443
brontosaurus weight, 99
cheetah speed, 437
cicada periods, 155
cricket chirps, 195
dog jumping, 436
elephant food consumption, 279, 467
elephant size, 468
fishbowl counting, 49
fish in aquarium, 506
fish weight, 181, 183
heights of, 443
leaf-cutting ant strength, 295
llama travel rate, 279
ostrich strides, 60
pet carrier volume, 522
reptile length, 443
rhinoceros beetle strength, 293–294
sea lion diet, 402
snake speed, 436
wildlife population, 296

Business

amortization, 359
banking, 99
budgets, 33, 67, 324, 349, 390–391, 399–400, 403, 477, 547, 561, 564, 604
buying power, 46
check writing, 11, 100
commissions, sales, 337, 339, 340, 367
company expenses, 165
corporate tax, 131
delivery schedules, 155
down payment, 306, 318
e-mail use, 21
employment numbers, 631
exchange rates, 255, 256
exports, 256
factory production rates, 289, 300
failures, 256
gold prices, 367
hourly salary, 195, 278
manufacturing rate, 289, 300, 303
operating costs, 257
per-word pay rates, 301
property tax, 287
radio station ownership, 313
refinery production, 278
revenue, 80
sales increase, 342, 367
sales per employee, 278
shorthand speed, 69
simple interest, 333–334, 339, 340, 367, 429, 477
stress at work, 385
time spent analysis, 165
total sales, 239, 241, 243
travel, most expensive cities, 388

typing speed, 20
wholesale price, 346
working late, 407
work stress, 385

Construction

antenna height, 95–96, 109
bench volume, 525
blueprints, 146
bookstore size, 453
bridge poles, 534
building height, 32, 46, 552
carpentry, 164, 175
casino area, 455
cement mixing, 195
Empire State Building, 32
fencing, 498
levies, 552, 593
model scale, 146, 287
waste dumping, 131
wood thickness, 164, 175

Consumer Issues

aspirin size, 442
ATM service preferences, 394
attendee count, 143
automobile ownership by type, 404
babysitting pay, 88
bequests, 165
boat registration, 8
books, money spent on, 614
bottle capacity, 141
car insurance, 100, 394, 614
car ownership, 404
car prices, 106, 346, 350
car rental costs, 231, 257, 622, 646, 657, 662, 663
cars, things kept in, 382
car sales, 18–19, 20, 23, 33, 34, 43, 46
car size, 436
cars to people ratio, 265, 273, 287, 299
cell phone bills, 254, 255
cell phone dimensions, 496
cell phone features, 312
cell phone use appropriateness, 313
cell phone users, 422
checkbook balancing, 219
childcare costs, 9
cities, salaries in various, 416
classified ad rates, 279, 281
clothing expenditure, 98
clothing manufacture, 144
coins, 192
cola preferences, 374–375
computer prices, 21, 46, 98
computer size, 144
computer speed, 633
computer trouble, 291
coupon use, 324
credit cards, 357
credit scores, 122, 218, 241, 296, 325
dating websites, 348
department store size, 453
detergent cost, 191
discounts, 337, 339, 340, 367
dollars and cents conversion, 224
dollar stores, increase in, 348
download speeds, 231
energy conservation, 228, 231, 232
energy use, 69
gas prices, 61, 275, 408, 414
grocery expenditure, 390–391
happiness, 314
hat size, 535
health insurance, 256
hours worked, 121, 175, 376
housing expenditure, 391
income and location, 416
inheritance, 165
Internet population, 259, 271, 295, 565
Internet speeds, 231
Internet use, 21, 313, 348, 376, 405, 417, 626, 651
job satisfaction, 402
junk e-mail, 376, 418
lollipop price, 221
magazine sales, 392
making change, 218
monthly expenses, 69, 220
moods, 585
mouthwash, 460, 461
nail polish remover, 295
newspaper expenditures, 175
online spending, 423, 426
paper use, 69, 615
pay rate, 278
phishing, 652
phone calls, unwanted, 387
pints in a flat, 56
plastic bags, 10
price to earnings ratio, 132
race and buying power, 378
rent costs, 261, 263, 265, 391
roast price, 222
sale prices, 91, 251, 337, 339, 340
scalping of tickets, 348
shopping mall visits, 348
social networks use, 130
Social Security deductions, 256
spam e-mail, 376, 418
spending totals, 218
stamp cost, 65
Supercenter stores, increase in, 348
tax software use, 348
tips, 100, 338, 340
tomato sauce cost, 190
toothpaste quantity, 144
toothpaste squeezing methods, 394
train schedules, 154
tuna price, 225
unemployment tax, 256
unit cost, 191, 196, 265, 279, 280, 281, 300, 301, 369, 388, 428, 650
unwanted phone calls, 387
used car purchase, 20

water use, 131, 402, 523
work hours, 175

Education

ACT scores, 256
attendance, 9
back to school spending, 385
Challenge Index, 273, 287
college expenses, 325
commuting, 255, 423, 426
completion rate, at university, 280
consolidation loans, 348
core curriculum hours, 429, 478, 548, 604, 665
costs, 28–29, 46, 47, 48, 69, 96, 99, 100, 166, 255, 257, 279, 321, 327, 342, 343, 349, 382, 385, 389, 403, 404
course completion rates, 280
course success rates, 312
daily routine, 401
earnings and, 8, 17, 255, 343, 355, 416
enrollment statistics, 615
first year course success, 312
gender discrimination, 418
grade point averages, 256, 410, 414, 418, 424, 426
grants, 99
inappropriate language use, 241
Internet knowledge by age, 388
loans, 326–327, 334–335, 339, 348, 355, 358
male to female student ratios, 299
manuscript letter count, 80
online, 375
pages in paper, 294
pencil length, 442
professor Internet use, 405
SAT scores, 563
saving for, 325
saving money, 324, 573
scholarships, 99, 321
school supply spending, 385
sheet music, money spent on, 614
Stafford loans, 355, 358
student enrollment, 615
student loans, 358
student routines, 401
student-teacher ratios, 273
teacher-student ratio, 133
test scores, 325
transportation for, 379
university president salaries, 414

Entertainment

alcoholic beverages, money spent on, 615
aspect ratio, 270, 288
Bible chapters, 32
computer game use, 372
cruise ship deck space, 454

cruise ship total area, 455
Digital Media Universe measurements, 377
digital music, 421, 425
downloading music, 387, 425, 427
expenditure, 345, 391
marriage proposal location, 426
Miss World measurements, 443
movie attendance, 387
movie revenue, 20, 183, 257
music, digital, 421, 425, 427
music downloads, 422
music preferences, 202, 495
music purchase methods, 387
music sales, 257
paper folding, 80
restaurant seating capacity, 311
screen area, 144
seating capacity, 311
television, households reached, 348
television height, 533
television screen dimensions, 443
television viewing times, 183
ticket scalping, 348
tickets purchased, 69
vacation cost, 85
vacation types, 380, 404
video game use, 372
wheel of fortune, 514

Environment

air pollution, 19
Amazon rainforest, 281
bottled water, 630
carbon emissions, 56, 61, 175, 253, 281, 571, 584, 593
coal power, 81
electric bulbs, 21, 374, 389, 580, 581, 584
electricity costs, 233
electric power, 80, 494
energy conservation, 97, 310, 322, 584
energy consumption, 87
environmental lapse, 573
ethanol, 459, 461
fuel savings, 29, 45, 322
garbage, 79, 384, 465, 612, 624
garbage pizza, 166
gas reserves, 324
geothermal ventilation, 101
glaciers, 447, 454
global warming, 10, 215, 409
greenhouse emissions, 175, 330, 347
greenhouse gap survey, 273
greenhouse remodeling, 239
hurricanes, 10
ice covering, 443
ice melting, 448
ice shelves, 10
nuclear power, 80
oil reserves, 324
paper use, 69, 196, 615

pollution, 10, 181, 463–464
recycling, 7, 10, 31, 100, 123, 153, 191–192, 232, 295, 377, 490, 612, 648
sea levels, 448, 640
solar energy, 81
solar panels, 142, 145
temperature change, 560, 642
water conservation, 101, 122–123
water leaks, 68
water usage, 119
windows and insulation, 246

Finances

account balance, 107
annual income, 241, 414
annual percentage rate, 357, 367
balance transfers, 357
bank deposits, 48, 650, 663
bill calculation, 254
budgets, 33, 69, 345, 352, 356, 390–391, 399–400, 403, 477, 547, 561, 564, 604
buying power, 46
car sales, 18–19, 20, 23, 33, 34, 43, 46
certificate of deposit, 339, 348, 622, 647, 651, 657
checking account balance, 43, 46, 339, 552
checking account deposits, 33, 561
checking deposits, 33
check writing, 11
commission, 365, 367
compound interest, 335–336, 339, 340, 365, 367, 624, 659
computer prices, 21, 46
corporate tax, 131
credit card fees, 351, 352, 354–355
credit scores, 122, 218, 241, 296, 325
depreciation, 346, 367
earnings estimates, 47
economic conditions, 395
education and income, 17
family budget, 399–400, 403, 547, 604
finance charges, 326, 334–335, 357, 367
household income, 46
income levels, 70, 341, 345, 347, 350, 429, 477, 547, 604, 665
income tax, 339, 340, 393
inflation, 295
interest rates, 56, 60, 326–327, 334–335, 339, 340, 356, 357, 360, 365, 367, 429, 477, 624, 647, 650, 651
investing, 340, 573, 626, 651
investment returns, 339
liquidity, 287
monthly payments, 107
net income, 46
profit, 46, 287, 316, 572, 650
property tax, 287

▶ Applications Index

salary, 67, 69, 108, 241, 348, 414, 417, 642, 650, 651
sales commissions, 337, 339, 340, 367
sales tax, 321, 333–334, 339, 340, 367, 428
silver prices, 256
simple interest, 365
solar tax credit, 338, 347
solvency, 287
stock losses, 572, 573
stock prices, 70, 200, 256, 287, 295, 342, 348, 562
stock purchase, 297, 300, 301
stock ratio, 119
stock shares, 69
taxable income, 340
tax deductions, 256
tax payments, 315
tax rates, 339, 340
tax returns, 21, 46
tax revenue, 121, 131
vacation costs, 85
wage gap, 270, 272

Food

bagel consumption, 631
banana sizes, 436
banana splits, 436
bread slicing, 194
bread volume, 526
breakfast consumption, 397
burger prices, 424
burger sales, 421, 425, 427
caffeine content, 651
calories, 32, 70, 99, 279, 572
candy, 98, 164
carbohydrate calories, 88
cheeseburger nutritional content, 378
cheese production, 401
cholesterol content, 426
coffee cup volume, 523
cookie recipe, 194
doughnut recipe, 152
expenditure, 390–391
fat content, 88, 118–119, 295, 424
favorite fast food restaurants, 376
food, 655
fresh fruit expenditure, 390–391
hamburger beef content, 526
hamburger calories, 409, 649, 657
hamburger cholesterol content, 426
hamburger fat content, 424
hamburger prices, 424
hamburger recipe, 136
hot dog buns, 166
individual calories, 99
lemonade recipe, 195
lollipop price, 221
meatball recipe, 143
meat consumption, 631
milk calories, 409
milkshakes, 32

nutritional content, 132, 241, 378
omelet area, 60, 514
paella, 32
pancake recipe, 194
pizza area, 514, 515, 593
pizza ingredients, 402
pizza sizes, 593
popcorn balls, 194, 277
popcorn consumption, American, 6
potato chip preferences, 404
protein calories, 88
punch recipe, 195
recipe proportions, 175
recipe unit conversions, 455, 458, 475
rice cost, 195
roast price, 222
sausage length, 436
serving sizes, 194, 295
sodium content, 99
soft drink preferences, 374–375
strawberry counting, 57–58
sugar container volume, 523
sugar content in soft drinks, 325
sweet roll recipe, 152
tamale recipe, 155
tomato sauce cost, 190
tomato soup recipe, 458
tortilla consumption, 278
tuna price, 225
vegetable consumption, 256, 631
vegetable expenditure, 390–391
water content of soft drinks, 245, 325
watering crops, 295
weight of, 131, 132
wheat costs, 241

Geometry

American flag measurements, 273, 284, 301, 303, 369, 428, 477
angles of Bermuda triangle, 488, 490
of petroglyphs, 488
area of baseball diamond, 514
area of bicycle wheel, 514
area of buildings, 454
area of crop circles, 510, 514, 516
area of Disneyland Carousel, 514
area of Fermi accelerator, 510
area of football field, 514
area of irregular figures, 515
area of pizza, 514
area of room, 201
area of storm, 514
box volume, 524
circumference, 269, 299, 301
cone volume, 520
diameter, 269, 299, 301
distance traveled by Venus, 502
funnel volume, 524
height of televisions, 533
land area, 245
length of conveyor belt, 533
Monaco, area of, 454

paper length, 294
perimeter of baseball diamond, 504
perimeter of exercise area, 502
perimeter of largest drydock, 504
perimeter of largest pool, 504
perimeter of Mona Lisa frame, 504
perimeter of room, 203, 207
pyramid volume, 524
scale
on blueprints, 146
on maps, 144, 295
on models, 146, 287
solar eclipse angles, 486
volume of bottle, 141
volume of bowling ball, 519
volume of funnel cloud, 524
volume of garbage can, 526
volume of garbage truck, 526
volume of pyramid of Giza, 520
volume of pyramid of the Moon, 524
volume of pyramid of the Sun, 524
volume of soda can, 518
volume of spherical water tank, 523
volume of sugar container, 523
volume of u-haul truck, 525
volume of UPS mailbox water volume, 196

Government

defense spending, 131
federal government revenue, 403
gas reserves, 324
intellectual property, 652
military, women in, 387
national debt, 552, 626
oil reserves, 9, 80, 324, 325
Pentagon (building), 33
petroleum reserves, 626
security breaches, 652
solar tax credit, 338, 347
tax revenue, 121, 131
women in military, 387

Home and Garden

air conditioning costs, 230
appliances, 21
area of house, 454
area of room, 141
baseboard molding, 175
bathroom time, 313
bedding purchases, 85
bed length, 442
carpeting, 102, 145, 454
chore participation, 175, 404
cleaning, and unit conversions, 457, 475
composting, 231
cow sales, 34
dinner plate area, 514
dishwashing, 69
electricity costs, 233
electric meter, 7, 11

electric meter readings, 7, 11
 fertilizer coverage, 300, 428
 framing, 504
 garbage, 79, 163, 256, 384, 402, 465, 612, 624, 632
 garbage can volume, 526
 gardening, 103
 gas meters, 231
 geothermal ventilation, 101
 greenhouse remodeling, 239
 home loans, 358, 376
 home purchase, 241
 hot tub volume, 523
 housework time, 131
 husband chore participation, 175, 404
 income, 562
 indoor water use, 402
 junk mail, 294
 lawn food cost, 275
 lawn food coverage, 294, 301, 303
 lawn mowing pay, 18, 88
 lawn watering, 514
 lighting costs, 231
 living room size, 442
 mortgages, 358, 367
 oven cleaner, 457
 painting, 102
 pasture area, 143
 peat moss coverage, 194
 perimeter of room, 173, 175
 pool size, 60, 504
 property damage, 373
 Purchase, 241
 purchase, 141
 recycling, 7, 10, 31, 100, 123, 153, 231, 232, 295, 377, 490, 612, 648
 room size, 141, 145, 173, 175
 rug cleaner, 460, 462
 rye grass seed, 290
 screw penetration, 144
 seed coverage, 291, 297, 300, 301
 sod coverage, 454
 soil removal volume, 521
 solar panels, 142, 145
 subdivision lots, 37
 superinsulation, 295
 swimming pool length, 443
 swimming pool perimeter, 504
 swimming pool volume, 358
 toilet volume, 523
 toilet water use, 241
 tomato plant growth rate, 279
 wallpaper, 454
 watering, 295
 water leaks, 68
 water saving, 101
 water usage, 119, 131
 windows and insulation, 246, 295
 yard area, 514

Law Enforcement

blood alcohol and traffic fatalities, 386
 calls, 288, 420

cell phone 911 calls, 288, 420
 software piracy, 376, 405
 speed limits, 443
 traffic fatalities, 386

Medicine and Health

antibiotic dosage, 293, 652
 body composition, 218
 body mass index, 98, 247, 249, 250, 262, 263
 body measurements, 532
 body proportions, 282
 body temperature, 175, 255, 256, 467
 body weight, 468
 bone lengths, 232, 443
 bone makeup, 165, 175
 brain weight, 175
 breast cancer risk, 383–384
 caloric intake, 60, 88, 655
 calorie counting, 32
 calories burned, 98, 100, 231
 cancer-obesity link, 247
 cardiac health, 332
 cold remedies, 155
 desirable body weight, 468
 diameter of aspirin, 442
 dieting, 645
 dieting rates, 397
 dosing, 88, 293
 dosing of medication, 88, 293
 exercise, 98, 100, 178, 486, 651, 653
 eye drops, 460, 461
 false teeth, 241
 fever, 468
 fluid intake, 460
 germs on phone, 9
 health care costs, 392, 411, 420
 heart disease risk factors, 33
 heart health, 332
 heart rate, 85, 178
 heat waves, 468
 heavy lifting, 20
 hemoglobin, 80
 hepatitis C infection, 652
 HIV infection, 652
 hormone replacement therapy, 380
 hospital website use, 348
 ideal weight, 468
 insurance, 256
 intravenous fluids, 458, 460
 metabolic rate, 98, 653
 metric system, 458
 migraines, 241
 nighttime pain, 183
 obesity, 295
 obesity-cancer link, 247
 protein intake, 293, 297, 300, 301, 303, 369, 428, 477
 pulse rate, 594
 risk of diseases, 383–384
 showers as sleep, 290
 sleeping pill consumption, 241

sleep time, 121, 183
 smoking, 20, 165, 175, 218
 soft drink consumption, 632
 stress causes, 381, 385
 stroke risk, 383–384
 vitamins, 460
 waist size, and heart disease, 332
 water consumption, 295
 water intake, 460
 weight loss, 20, 61, 99, 653, 657

Science

age and Internet knowledge, 388
 air pollution, 19, 314, 325
 anthropology, 232, 443, 646
 ash weight, 183
 astronomy, 147, 156, 629, 633
 atomic valences, 574, 656
 atom smasher area, 510
 bamboo growth rate, 279
 biodiesel, 655
 carbon monoxide, 56, 325
 Celsius-Fahrenheit conversion, 467
 child population, 324
 Clarice's rule, 89, 297
 clock hand movement, 504
 coal power, 81
 coal reserves, 325
 crater area, 514
 crop circles, 510, 514
 disk space, 652
 distances, in space, 80
 Einstein's problem, 594
 electric power, 80, 494
 elevation, 46, 443, 552, 573, 593
 energy production, 403
 Fahrenheit-Celsius conversion, 467
 Field's rule, 89
 genealogy, 31
 gold, melting point of, 467
 gold weight, 32
 greenhouse emissions, 175
 growth rate, 278
 hemlock weight, 183
 Hispanic population, 348
 historical dates, 564
 hours, fractions of, 121
 hours in days, weeks, months, 60
 jumbo jet weight, 629
 Jupiter's orbit, 505
 kindling point, 49
 light, distance traveled by, 60
 light speed, 632
 Louisiana sinking rate, 453
 melting point of gold, 467
 metallurgy, 203
 metal weights, 249
 nuclear power, 80
 ocean coverage, 249
 ocean depth, 561
 orbital period, 156
 oxidation number, 656

► Applications Index

pendulum volume, 525
planetary alignment, 147
planetary paths, 502, 505
pollution, 61, 181, 314, 325, 406,
463–464, 477, 547, 604
population, 20, 99, 324, 423, 425, 561,
655, 656
population density, 288, 632
population increase, 325, 348, 593
satellite paths, 486
solar eclipses, 486
solar energy, 81
solar panels, 142, 145
space, weights in, 60, 143, 258, 654
space travel, 80
specific heat, 249
temperature, 131, 560, 642
 body, 175, 468
 conversion, 195, 467, 468
 differences, 559, 563
thermometer readings, 552, 593
Venus, distance traveled by, 502
water
 oxygen in, 646
waterfall heights, 46
water flow, 61
water pollution, 406
water temperature, 559
weights
 of ash, 183
 desirable, 467
 of fish, 184
 fractions of, 118, 121
 of metals, 249
 on moon, 644
 in space, 60, 143, 258, 654
wind turbine, 81
Young's rule, 89

Social Studies

age and movie attendance, 387
age and traffic fatalities, 386
age demographics, 395
auto theft, 14
buying power by race, 378
race discrimination, 419
votes received, 651
world records, 437

Sports

baseball diamond area, 60, 514
baseball diamond distances, 530
baseball diamond perimeter, 60, 504
baseball salaries, 411, 414, 416

baseball stadium perimeter, 32
baseball statistics, 131
baseball timing, 129
basketball court area, 60
basketball court perimeter, 32
basketball player height, 442
basketball salaries, 413
basketball scoring rate, 278
batting averages, 240
bicycles to people ratio, 287
bicycle tires, 504
bowling ball volume, 519
bowling handicaps, 587
boxing, 32
boy and girls participation in, 389
cards, 131
diving records, 218
drydock size, 504
fishing, 20
football completions, 240
football field area, 514
football field size, 33, 61
football punts, 443
gender and sports participation, 389
golf, 493, 552, 566
hockey rink size, 33, 61
home runs, 241
jogging, 654
passing, in football, 46
playing cards, 131
points per game, 231
preferences, 205
race length, 442, 443
running speed, 195
soccer field length, 449
softball diamond distances, 530
stride length, 443
Super Bowl ticket prices, 348
swimming pool depth, 442
tennis, 493
weightlifting, 493
weight of players, 70
wrestler weight, 468

Transportation

abroad, 122
airline passenger numbers, 348
airplane takeoff lengths, 453
airport baggage handling, 348
alcohol and traffic fatalities, 386
altitude, 573, 593
automobile expenses, 398, 403
auto theft, 14
average speed, 100
baggage problems, air travel, 348

business, 388
bus schedules, 154
distance on tank of gas, 60, 124
distances, 34, 253, 257, 505
distances between destinations, 220
distance traveled, 34, 124, 144, 219,
220, 231, 253, 257, 281, 447,
505, 533
elevators, 564
expenses, 626
flight records, 99
flight times, 348
fuel tank volume, 523
gas costs, 230
gas mileage, 69, 123, 231, 278,
301, 428
gas octane rating, 593
gas reserves, 325
gas tank readings, 123
jet engine speed, 99
maps, money spent on, 614
map scale, 145, 295
metro park stations, 531
motor oil disposal, 61
oil consumption, 60
oil demand, 649
online planning, 348
online travel planning, 348
plane speeds, 278
public transportation, 154
road signs, 216
runway lengths, 453
to school, 379
speed, average, 100
taxi use, 17
trip length, 46, 216
truck volume, 525
walking speed, 437
to work, 165, 398, 426

Weather

annual rainfall, 429, 478
flooding, 552, 593
funnel cloud volume, 524
on Internet, 651
kinds of, 165
rainfall amounts, 9, 143, 175, 183,
429, 478
rainy days, 241
storm area, 514
storm size, 514
sunny days, 241
temperature, 131, 429, 468, 478, 547,
559, 598, 602–603
tornado volume, 525

Section

Chapter

- 1.1** Standard Numerals
- 1.2** Ordering and Rounding Whole Numbers
- 1.3** Addition
- 1.4** Subtraction
- 1.5** Multiplication
- 1.6** Division
- 1.7** Primes, Factors, and Exponents
- 1.8** Order of Operations and Grouping Symbols
- 1.9** Equations and Problem Solving

1

one

▶ Whole Numbers



The Human Side of Mathematics

The development of the number system used in arithmetic has been a multicultural undertaking. More than 20,000 years ago, our ancestors needed to count their possessions, their livestock, and the passage of days. Australian aborigines counted to two, South American Indians near the Amazon counted to six, and the Bushmen of South Africa were able to count to ten using twos ($10 = 2 + 2 + 2 + 2 + 2$).

The earliest technique for visibly expressing a number was tallying (from the French verb *taller*, “to cut”). Tallying, a practice that reached its highest level of development in the British Exchequer tallies, used flat pieces of hazelwood about 6 to 9 inches long and about an inch thick, with notches of varying sizes and types. When a loan was made, the appropriate notches were cut and the stick split into two pieces, one for the debtor, and one for the Exchequer. In this manner, transactions could easily be verified by fitting the two halves together and noticing whether the notches coincided, hence the expression “our accounts tallied.”

How do other cultures write numerals? The development of written numbers was due mainly to the Egyptians (about 3000 B.C.), the Babylonians (about 2000 B.C.), the early Greeks (about 400 B.C.), the Hindus (about 250 B.C.), and the Arabs (about 200 B.C.). The table shows the numbers some of these civilizations used.

In this chapter, we shall study operations with whole numbers and their uses in present-day society.

Egyptian, about 3000 B.C.

	∩	⊖	⋈	∩	∩	⋈
1	10	100	1000	10,000	100,000	1,000,000

Babylonian, about 2000 B.C.

ξ	▼	◀	◀◀	◀◀	▼	◀
0	1	10	12	20	60	600

Early Greek, about 400 B.C.

	Γ	△	⌒	⌒	⌒	⌒
1	5	10	50	100	500	5000

1.1

Standard Numerals

▶ Objectives

You should be able to:

- A > Determine the place value of a digit in a numeral.
- B > Write a standard numeral in expanded form.
- C > Write an expanded numeral in standard form.
- D > Write a standard numeral in words.
- E > Write a numeral given in words in standard form.
- F > Write the number corresponding to the given application.

▶ To Succeed, Review How To . . .

Recognize the counting numbers (1, 2, 3, and so on).

▶ Getting Started

In the following cartoon, Peter has used the **counting numbers** 1, 2, 3, and so on as mileage indicators. Unfortunately, he forgot about 4! In our number system we use the ten **digits** 0, 1, 2, 3, 4, 5, 6, 7, 8, and 9 to build **numerals** that name **whole numbers**. **Number** and **numeral** are closely related concepts (sometimes we use the terms interchangeably). A **number** is an abstract idea used to represent a quantity, whereas a **numeral** is a symbol that represents a number. In the cartoon, “four” is a number represented by the numeral 4. In Roman times, the number “four” would be represented by the numeral **IV**. Similarly, the marker on the last mileage indicator is “two hundred one,” or 201, or **CCI** in Roman numerals. We have written 201 two ways: in the standard form **201** and in words, **two hundred one**. In this section, we will learn how to write numerals three ways: in standard form, in expanded form, and in words. But before doing so we will explore how digits can have different values depending on their placement in a numeral.

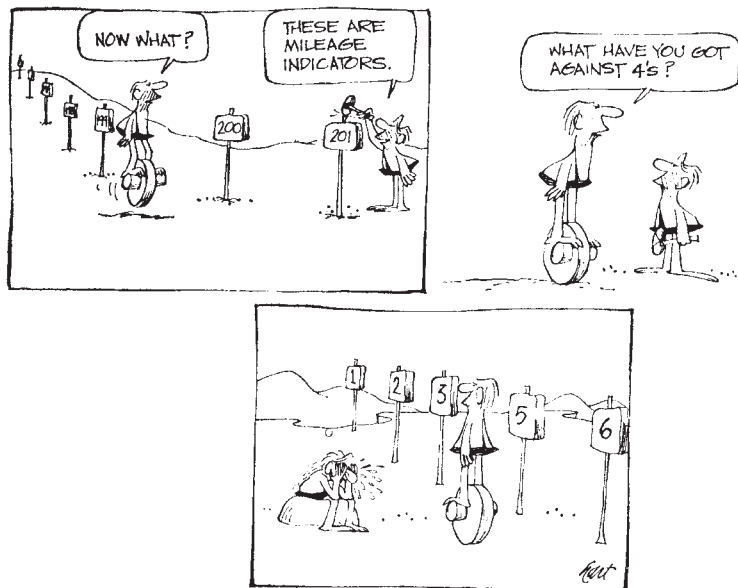

By Permission of John L. Hart FLP, and Creators Syndicate, Inc.

A > Place Value

The position of each digit in a number determines the digit’s **place value**. Look at the world population clock. Which is the only digit that is missing? Which digits are repeated? What is the **value** of the digits that are repeated? It depends! To help you with the answer, we use a place value chart in which each group of three digits is called a **period**. We name these periods *ones*, *thousands*, *millions*, *billions*, *trillions*, *quadrillions*,

The Population of the Earth is

6,511,257,348

To see the current population, try
<http://www.census.gov>

quintillions, and so on. Each period has three categories: *ones (units)*, *tens*, and *hundreds* separated by commas. (Note: Commas are usually omitted in four-digit numbers, such as 3248 and 5093.)

Now, place the **6,511,257,348** in the chart

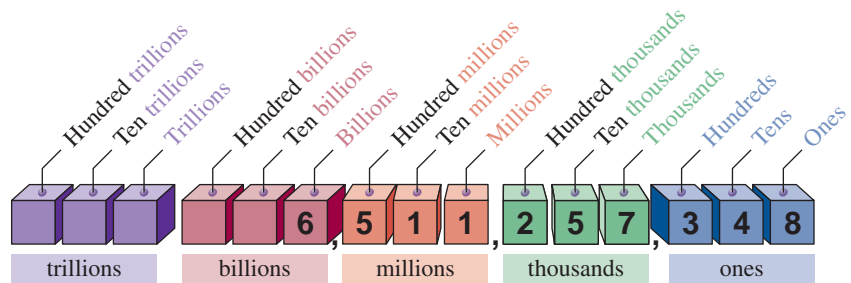

The U.S. National Debt is \$11,174,727,533,881.98. Can you use the diagram and read this number? The current figure is at: http://www.brillig.com/debt_clock/.

What is the value of the **1** (there are two of them)? Either **1 million** or **1 ten millions**. The value of **5** is either **5 ten thousands** or **5 hundred millions**. Get the idea? Just read the column (upward) using the category and the period in which the desired number appears.

EXAMPLE 1 Finding the value of a digit
Referring to the population of the earth, find the value of
a. 6 b. 3 c. 4

SOLUTION 1

- a. The 6 appears in the **billions** column; its value is **6 billion**.
- b. The 3 is in the **hundreds** column; its value is **3 hundred**.
- c. The 4 is in the **tens** column; its value is **4 tens**.

PROBLEM 1
Find the value of
a. 2 b. 7 c. 8

The numeral **6,511,257,348** is an example of a *whole number*. The set of whole numbers is

$$0, 1, 2, 3, 4, 5, 6, 7, 8, 9, 10, 11, 12, \dots$$

The *smallest* whole number is **0**, and the pattern continues *indefinitely*, as indicated by the three dots (*...*) called an *ellipsis*. This means that there is no *largest* whole number. If 0 is omitted from the set of whole numbers, the new set of numbers is called the **natural** or **counting** numbers. The natural numbers are

$$1, 2, 3, \dots$$

As promised, we will now learn how to write numbers in standard form, in expanded form, and in words.

B > Expanded Form of a Numeral

The **standard numeral** for the last mileage indicator in the cartoon is 201. Here are other standard numerals: 4372 and 68. Standard numerals such as 4372, 201, and 68 can be written in **expanded form** like this:

4	3	7	2	=	4000	+	300	+	70	+	2
2	0	1	=	200	+	0	+	1*			
6	8	=	60	+	8						

Answers to PROBLEMS

- 1. a. 2 hundred thousand
- b. 7 thousand
- c. 8 ones (units)

* 201 can also be written in expanded form as 200 + 1.

EXAMPLE 2 Writing numbers in expanded form

Write 4892 in expanded form.

SOLUTION 2

$$4892 = 4000 + 800 + 90 + 2$$

PROBLEM 2

Write 9241 in expanded form.

EXAMPLE 3 Writing numbers in expanded form

Write 765 in expanded form.

SOLUTION 3

$$765 = 700 + 60 + 5$$

PROBLEM 3

Write 197 in expanded form.

EXAMPLE 4 Writing numbers in expanded form

Write 41,205 in expanded form.

SOLUTION 4

$$\begin{aligned} 41,205 &= 40,000 + 1000 + 200 + 0 + 5 \text{ or} \\ &= 40,000 + 1000 + 200 + 5 \end{aligned}$$

Note that when zeros occur in the given numeral, the expanded form is shorter.

PROBLEM 4

Write 98,703 in expanded form.

EXAMPLE 5 Text messaging queen

In January 2009, Reina Hardesty set a record high 14,528 text messages in a 1-month period. Write 14,528 in expanded form.

SOLUTION 5

$$14,528 = 10,000 + 4000 + 500 + 20 + 8$$

PROBLEM 5

About 8 billion text messages are sent everyday, which comes to about 92,593 messages every second. Write 92,593 in expanded form.

C > Standard Form of a Numeral

We can also do the reverse process, that is, we can write the standard form for

$$\begin{array}{ccccccc} 3000 & + & 200 & + & 80 & + & 9 & \text{ as} \\ \swarrow & & \downarrow & & \swarrow & & \swarrow & \\ 3 & & 2 & & 8 & & 9 & \end{array}$$

EXAMPLE 6 Writing numbers in standard formWrite $7000 + 800 + 90 + 2$ in standard form.**SOLUTION 6**

$$\begin{array}{ccccccc} 7000 & + & 800 & + & 90 & + & 2 & \text{ is written as} \\ \swarrow & & \downarrow & & \swarrow & & \swarrow & \\ 7 & & 8 & & 9 & & 2 & \end{array}$$

PROBLEM 6Write $9000 + 200 + 20 + 5$ in standard form.**EXAMPLE 7** Writing numbers in standard formWrite $70,000 + 6000 + 300 + 20 + 1$ in standard form.**SOLUTION 7**

$$\begin{array}{ccccccc} 70,000 & + & 6000 & + & 300 & + & 20 & + & 1 & \text{ is written as} \\ \swarrow & & \downarrow & & \swarrow & & \swarrow & & \swarrow & \\ 7 & & 6 & , & 3 & & 2 & & 1 & \end{array}$$

PROBLEM 7Write $10,000 + 1000 + 100 + 10 + 1$ in standard form.**Answers to PROBLEMS**

2. $9000 + 200 + 40 + 1$ 3. $100 + 90 + 7$ 4. $90,000 + 8000 + 700 + 3$ 5. $90,000 + 2000 + 500 + 90 + 3$ 6. 9225 7. 11,111

EXAMPLE 8 Writing numbers in standard form
Write $90,000 + 600 + 1$ in standard form.

SOLUTION 8

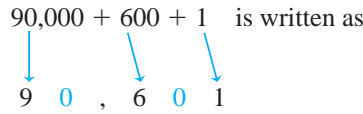

Note that a zero appears in the tens and in the thousands places of the answer, making the expanded numeral shorter.

PROBLEM 8
Write $50,000 + 200 + 6$ in standard form.

D > Numerals to Words

The amount of the lottery check shown here is \$294,000,000. Can you write this amount in words? Here we will show you how to do that, but we warn you that the word “and” used in writing “Two hundred and ninety four million” in the check is used incorrectly. Moreover, the amount in the check is not that large. According to the *Guinness Book of Records*, the greatest amount ever paid by a single check is \$16,640,000,000 and was paid by the U.S. government to the Ministry of Finance in India. Do you know how to read and write 16,640,000,000 in words? This amount is written as

sixteen billion six hundred forty million*



The number 16,640,000,000 can be placed in a chart like this:

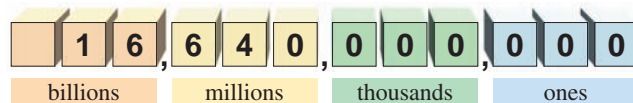

A **period** is a group of three digits.

In each period, digits are read in the normal way (“sixteen,” “six hundred forty”) and then, for each period except ones, the name of the period is added (“billion,” “million”). Note that “and” is not used in writing the word names for whole numbers.

Answers to PROBLEMS

8. 50,206

* In Europe and South America, a billion is a million millions, or 1,000,000,000,000.

EXAMPLE 9 Writing numbers in words

Write word names for each of the numbers.

SOLUTION 9

a. 85

Eighty-five

b. 102,682

We first label each period for easy reference as shown.
One hundred two *thousand*, six hundred eighty-two.

c. 13,012,825,476

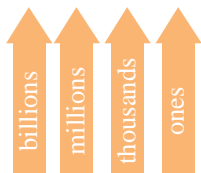
We first label each period for easy reference, as shown.
The word name is thirteen *billion*, twelve *million*, eight hundred twenty-five *thousand*, four hundred seventy-six.**PROBLEM 9**

Write word names for each of the numbers.

a. 93

b. 209,376

c. 75,142,642,893

E > Words to Numerals

We can reverse the process in Example 9 and write the word name of a numeral in standard form, as shown next.

EXAMPLE 10 Writing numbers in standard form

Write one hundred three million, eight hundred forty-seven thousand, six hundred eleven in standard form.

SOLUTION 10 Think of the value of each of the periods individually, like this:

one hundred three million, eight hundred forty-seven thousand, six hundred eleven

103, 847, 611

Then write your answer as 103,847,611.

PROBLEM 10

Write three hundred ten million, six hundred ninety-two thousand, seven hundred twelve in standard form.

EXAMPLE 11 Writing numbers in standard form

Write four billion in standard form.

Gobbling popcorn

Americans eat about 4 billion gallons of popped popcorn each year, with the average person munching about 15 gallons annually. That's enough popped corn to fill 70 four-cup-size popcorn boxes.

**SOLUTION 11** We have to include billions, millions, thousands, and ones.

4, 000, 000, 000

PROBLEM 11Americans eat one billion, one hundred twenty-five million pounds of popcorn each year. Write 1125 million in standard form.
Source: The Popcorn Board.**Answers to PROBLEMS**

9. a. Ninety-three b. Two hundred nine thousand, three hundred seventy-six c. Seventy-five billion, one hundred forty-two million, six hundred forty-two thousand, eight hundred ninety-three 10. 310,692,712 11. 1,125,000,000

F > Applications Involving Standard Numerals

The ideas discussed here can be used in everyday life. For example, the amount of electricity used in your house is measured by an electric meter that records kilowatt-hours (kWh). (An electric meter actually has *four* or *five* dials.) To read the meter we must use the standard form of the number involved. Thus, the meter below is read by starting at the left and writing the figures in standard form. When the pointer is between two numbers, we use the *smaller* one. In this manner, the reading on the meter is



EXAMPLE 12 Reading your electric meter

Read the meter.



SOLUTION 12 The first number is 6 (because the pointer is between 6 and 7, and we must choose the smaller number), and the next is 3, followed by 8 and 1. Thus, the reading is 6381 kilowatt-hours.

PROBLEM 12

Read the meter.



Some important and contemporary applications of mathematics concern the environment, ecology, and climate change, what we will call “**The Green Math.**” These applications will be clearly marked so you can pay special attention to them. Here is one of them.

GREEN MATH

EXAMPLE 13 Saving trees, water, and oil

By recycling one ton (2000 pounds) of paper, we save 17 trees, 6953 gallons of water, 463 gallons of oil, and 4077 kilowatt-hours of energy. Write word names for 17 and 6953.

SOLUTION 13 The word name for 17 is seventeen and the word name for 6953 is six thousand nine hundred fifty-three.

Source: SEED (Students Expressing Environmental Dedication).

PROBLEM 13

Write word names for 463 and 4077.

Calculator Corner

To the student and instructor: CALCULATOR CORNER exercises give the students the opportunity to see how the material relates to the features of an inexpensive scientific calculator.

1. What is the largest number you can enter on your calculator? Write the answer as a numeral and in words.
2. Do you have to use commas to enter the number 32,456 on your calculator?

Answers to PROBLEMS

12. 1784 13. 463 is four hundred sixty-three and 4077 is four thousand seventy-seven.

> Exercises 1.1

< A > **Place Value** In Problems 1–6, what is the value of the circled number?



Source: Data from National Marine Manufacturers Association.

5. 853,408
6. 853,448

>>> Applications: Green Math

In Problems 7–8, what is the value of the circled number?

Number of People Living without Electricity

Region	Millions without Electricity
7. Sub-Saharan Africa	5 4 7
8. East Asia	2 2 4

Source: Poverty Facts and Stats by Anup Sha <http://www.globalissues.org/>.

In Problems 9–12, what is the underlined place value?

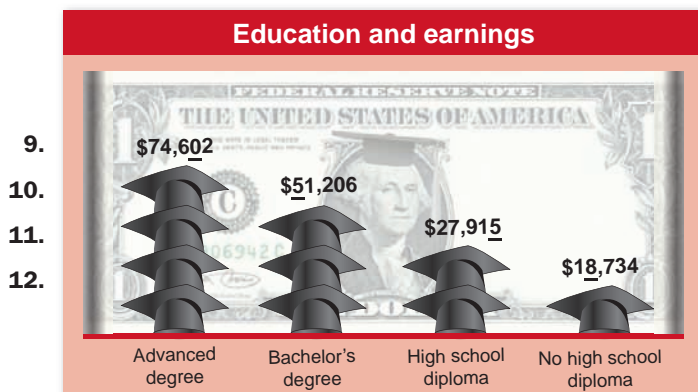

Source: Data from U.S. Census Bureau.

>>> Applications: Green Math

In Problems 13–16, what is the underlined place value?

Numbers of Threatened Species by Major Groups of Organisms (1996–2008)

Vertebrates	Number
13. Mammals	5488
14. Birds	9990
15. Reptiles	8 <u>7</u> 34
16. Fishes	<u>3</u> 0,700

Source: <http://www.iucnredlist.org/static/stats>.

< B > **Expanded Form of a Numeral** In Problems 17–36, write in expanded form.

- | | | |
|------------|-------------|------------|
| 17. 34 | 18. 27 | 19. 108 |
| 20. 375 | 21. 2500 | 22. 8030 |
| 23. 7040 | 24. 3990 | 25. 23,018 |
| 26. 30,013 | 27. 604,000 | 28. 82,000 |
| 29. 91,387 | 30. 13,058 | 31. 68,020 |
| 32. 30,050 | 33. 80,082 | 34. 50,073 |
| 35. 70,198 | 36. 90,487 | |

< C > **Standard Form of a Numeral** In Problems 37–56, write in standard form.

- | | | |
|---------------------------|-----------------------|---------------------------|
| 37. $70 + 8$ | 38. $60 + 3$ | 39. $300 + 8$ |
| 40. $600 + 5$ | 41. $800 + 20 + 2$ | 42. $600 + 30 + 6$ |
| 43. $700 + 1$ | 44. $900 + 4$ | 45. $3000 + 400 + 70 + 3$ |
| 46. $1000 + 600 + 10 + 2$ | 47. $5000 + 200 + 50$ | 48. $7000 + 500 + 20$ |
| 49. $2000 + 30$ | 50. $5000 + 60$ | 51. $8000 + 90$ |
| 52. $6000 + 3$ | 53. $7000 + 1$ | 54. $1000 + 300$ |
| 55. $6000 + 600$ | 56. $8000 + 70$ | |

< D > **Numerals to Words** In Problems 57–66, write word names for the numerals.

- | | |
|-------------------|--------------------|
| 57. 57 | 58. 109 |
| 59. 3408 | 60. 43,682 |
| 61. 181,362 | 62. 6,547,210 |
| 63. 41,300,000 | 64. 341,310,000 |
| 65. 1,231,341,000 | 66. 10,431,781,000 |

< E > **Words to Numerals** In Problems 67–76, write the given numeral in standard form.

- | | |
|--|---|
| 67. Eight hundred nine | 68. Six hundred fifty-three |
| 69. Four thousand eight hundred ninety-seven | 70. Eight thousand six hundred twenty-seven |
| 71. Two thousand three | 72. One million, two thousand |

73. Two million, twenty-three thousand, forty-five
75. Three hundred forty-five million, thirty-three thousand, eight hundred ninety-four

< F > Applications Involving Standard Numerals

77. *Cost of raising a child* The U.S. Department of Agriculture has determined that it costs about \$173,880 to raise a child from birth to age 18. Write the numeral 173,880 in words.
79. *School attendance* On an average day in America, 13,537,000 students attend secondary school. Write the numeral 13,537,000 in words.
81. *College attendance* On an average year in America, fourteen million, nine hundred seventy-nine thousand students are enrolled in colleges and universities. Write this number in standard form.

74. Seventeen million, forty-seven thousand, ninety-seven
76. Nine billion, nine hundred ninety-nine million, nine hundred ninety

78. *Germs on your phone* The average phone has 25,127 germs per square inch. Write the numeral 25,127 in words.
Source: Microbiologist Charles Gerba.
80. *Rainfall on an acre* A rainfall of 1 inch on an acre of ground will produce six million, two hundred seventy-two thousand, six hundred forty cubic inches of water. Write this number in standard form.
82. *Middle East oil reserves* The proven oil reserves of the Middle East are about six hundred eighty-five billion barrels. Write this number in standard form.
Source: BP Statistical Review of World Energy.

>>> Applications: Green Math

< E > **Words to Numerals.** In Problems 83–92, write the given numeral in standard form.

An Inconvenient Truth, a book by Vice-President Al Gore, is said to exaggerate the effects of Global Warming. Here are 10 items that are said to misrepresent the facts about Global Warming.

83. *Statement in the book* Sea level is rising **six** meters.
85. *Statement in the book* Polar bears are “dying.” As a matter of fact **four** bears died in a storm.
87. **One hundred** parts per million by volume of CO₂ is melting the mile-thick ice.
89. *Antarctic Peninsula ice shelves “breaking up”* Gore concentrates on the **two** % of Antarctica that is experiencing some warming.
91. *Hurricane Katrina “manmade”* (First South Atlantic hurricane, 2004). Air temperatures in the area were the coldest in **twenty-five** years, not warmest.
84. *Rebuttal* The IPCC’s (International Panel on Climate Change) maximum sea level rise estimate is a mere **fifty-nine** centimeters.
86. *Rebuttal* There are **twenty-five thousand** polar bears today compared to five thousand in 1940.
88. *Gore overstates the effect of CO₂* as **ten** times greater than even the IPCC’s highest estimate.
90. *Rebuttal* Gore neglects to mention the **ninety-eight** % of Antarctica that is cooling.
92. *Hurricanes “getting stronger”—rebuttal* They haven’t in **sixty** years.

Source: <http://scottthong.wordpress.com/2007/10/30/35-scientific-errors-or-intentional-lies-in-an-inconvenient-truth/>.

< F > Applications Involving Standard Numerals

93. *Sewage dumping* Americans dump over 15 tons of sewage into their streams and oceans every minute. Write 15 in words.
95. *Water usage* A typical family member uses over 80 gallons of water each day. Write 80 in words.
97. *Paper, metal, and glass discards* Each year, a typical American family throws away 2500 pounds of paper, 500 pounds of metal, 500 pounds of glass and food scraps. Write 2500 in words.
94. *Pollution from gas* A gallon of gas burned by our cars contributes 19 pounds of carbon dioxide to the atmosphere. Write 19 in words.
96. *CFC (chlorofluorocarbon) atoms* A single CFC atom may remain in the atmosphere for up to 100 years before it becomes harmless. Write 100 in words.
98. *Plastic bags and six-pack holders* Plastic bags and six-pack holders kill 100,000 marine mammals and over 1 million sea birds. Write 100,000 in words.

99. Using paper to heat homes We throw away enough paper each year to heat 50 million homes for 20 years. Write 50 million in standard form.

100. Dangerous pollution levels Over one hundred million Americans live in areas with air pollution levels considered harmful by the government. Write one hundred million in standard form.

101. CFCs in polystyrene cups One single polystyrene cup contains one billion molecules of CFCs. Write one billion in standard form.

102. Aluminum can waste Americans throw away enough aluminum cans, approximately 40 billion, to reach the moon and back over 20 times. Write 40 billion in standard form.

Source: Centerline Designs at <http://www.reddawn.com/greenfaq.html>.

In Problems 103–106, read the meter. (See section F, Example 12.)



Using Your Knowledge

Writing Checks Check this out! In problems 107–111, fill in the appropriate blank in the check.

107.

CHARLES SMITH
205 FAIR ST.
FORT BLAT, IL 64521

60-8124/7233
1000824431

1024

DATE June 20

PAY TO THE ORDER OF Major Motors \$

Nine thousand seven hundred ninety-nine and ⁰⁰/₁₀₀ DOLLARS

CITIZENS BANK
OF EAGLE POINT
EAGLE POINT, IL 64502

MEMO New car Chuck Smith

⑆ 7 23360 240⑆ ⑆0008 2443 1⑆ ⑆0 24

108.

JAMES L. SEAGOER
1004 CREEKSIDE AVE.
FORT BLAT, IL 64539

60-8124/7233
1000824628

2872

DATE August 23

PAY TO THE ORDER OF Ship in Shake Co. \$

Eight thousand six hundred ninety-six and ⁰⁰/₁₀₀ DOLLARS

CITIZENS BANK
OF EAGLE POINT
EAGLE POINT, IL 64502

MEMO New boat James Seagoer

⑆ 7 23360 240⑆ ⑆0008 246 28⑆ 28 7 2

109.

ALICE SMART
1919 WILBER ST.
FORT BLAT, IL 64521

60-8124/7233
1000824777

988

DATE March 19

PAY TO THE ORDER OF German Autos \$ 28,900

DOLLARS

 **CITIZENS BANK**
OF EAGLE POINT
EAGLE POINT, IL 64502

MEMO New car Alice Smart

⑆ 7 2 3 3 6 0 2 4 0 ⑆ 1 0 0 0 8 2 4 7 7 7 ⑆ 0 9 8 8

110.

FELICIA PEREZ
115 MAYFAIR DR.
RICHFIELD, IL 64011

60-8124/7233
1000828741

2399

DATE April 2

PAY TO THE ORDER OF Exclusive Boats \$ 47,100

DOLLARS

 **CITIZENS BANK**
OF EAGLE POINT
EAGLE POINT, IL 64502

MEMO New yacht Felicia Pérez

⑆ 7 2 3 3 6 0 2 4 0 ⑆ 1 0 0 0 8 2 8 7 4 1 ⑆ 2 3 9 9

111.

JOSEPH CLEMENTE
1316 PARK ST.
FORT BLAT, IL 64539

60-8124/7233
1000824119

1381

DATE July 1

PAY TO THE ORDER OF Home Makers, Inc. \$ 90,800

DOLLARS

 **CITIZENS BANK**
OF EAGLE POINT
EAGLE POINT, IL 64502

MEMO New house Joe Clemente

⑆ 7 2 3 3 6 0 2 4 0 ⑆ 1 0 0 0 8 2 4 1 1 9 ⑆ 1 3 8 1

>>> Write On

To the student and instructor: The WRITE ON exercises give you an opportunity to express your thoughts in writing. They usually can be answered in a few sentences. Most of the answers to these exercises do not appear at the back of the book.

- 112. What is the definition of a period?
- 113. Why do we use commas when writing large numbers?
- 114. In the numeral 5678, what is the value of the 5?
- 115. In the numeral 5678, what is the value of the 8?
- 116. In the numeral 5678, what digit tells the number of hundreds?
- 117. In the numeral 5678, what digit tells the number of tens?

>>> Concept Checker

This feature is found in every exercise set and is designed to check the student's understanding of the concepts covered in the section.

Fill in the blank(s) with the correct word(s), phrase, or mathematical statement.

- 118.** 1, 2, 3, . . . are the numbers you use to count, that is, the _____ numbers.
- 119.** 0, 1, 2, 3, . . . are the _____ numbers.
- 120.** A _____ is an abstract idea used to **represent** a quantity.
- 121.** 1, 2, 3, 4, . . . are the _____ numbers.
- 122.** When a numeral is written as an **addition** of their place values it is in _____ form.
- 123.** A _____ is a **symbol** that represents a number.

number	natural
numeral	standard
whole	digits
expanded	counting

>>> Mastery Test

- 124.** Write $8000 + 600 + 90 + 3$ in standard form.
- 125.** Write the numeral 12,849 in words.
- 126.** Write 785 in expanded form.
- 127.** What is the place value of 6 in 689?
- 128.** Write “fifty-six thousand, seven hundred eighty-five” in standard form.
- 129.** Write 305 in words.

1.2

Ordering and Rounding Whole Numbers

▶ Objectives

You should be able to:

- A** > Determine if a given number is less than or greater than another number.
- B** > Round whole numbers to the specified place value.
- C** > Solve applications involving the concepts studied.

▶ To Succeed, Review How To . . .

Find the place value of a digit in a numeral. (p. 3)

▶ Getting Started

How long is a large paper clip?
To the nearest inch, it is 2 inches.

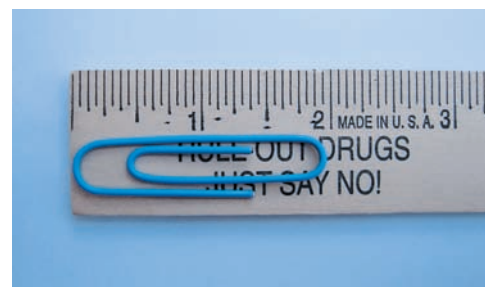

A > Ordering Numbers

We know that 2 is greater than one because the 2 on the ruler is to the **right** of the one. Whole numbers can be compared using the number line shown:

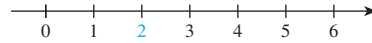

FOR ANY WHOLE NUMBERS a AND b

1. $a < b$ (read “ a is less than b ”) if a is to the **left** of b on a number line.
2. $a > b$ (read “ a is greater than b ”) if a is to the **right** of b on the number line.

Thus, $3 < 5$ because 3 is to the *left* of 5 on the number line. Similarly, $5 > 3$ because 5 is to the *right* of 3 on the number line. Sentences such as $3 < 5$ or $5 > 3$ are called **inequalities**. The inequality $3 < 5$ is true, but the inequality $3 > 8$ is false.

EXAMPLE 1 Creating true statements

Fill in the blank with $<$ or $>$ to make the resulting inequalities true.

- a. 27 ____ 28 b. 33 ____ 25

SOLUTION 1 We make a number line starting with 25.

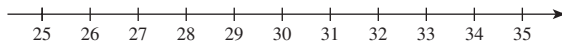

Since 27 is to the *left* of 28, $27 < 28$.

Since 33 is to the *right* of 25, $33 > 25$.

PROBLEM 1

Fill in the blank with $<$ or $>$ to make the resulting inequalities true.

- a. 23 ____ 25 b. 31 ____ 27

EXAMPLE 2 Ordering numbers

The graph shows the cities with the most auto thefts per 100,000 people.

- a. Order the *number* of auto thefts from smallest to largest.
- b. Which city had the smallest number of auto thefts?

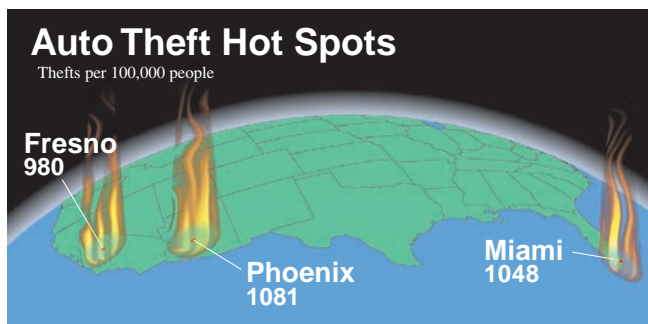

Source: Data from National Insurance Crime Bureau Study.

PROBLEM 2

- a. Order the number of auto thefts from largest to smallest.
- b. Which city had the largest number of auto thefts?

SOLUTION 2

- a. To make sure we include the numbers 980 to 1081, we construct a number line starting at 950 and ending at 1100, as shown in Figure 1.1.



>Figure 1.1

Answers to PROBLEMS

1. a. $<$ b. $>$ 2. a. $1081 > 1048 > 980$ b. Phoenix

For convenience, we make 50 unit subdivisions, that is, we count by fifties. The line looks like Figure 1.2.



>Figure 1.2

The numbers 980, 1048, and 1081 are then placed on the line from left to right, as shown in Figure 1.3.



>Figure 1.3

Since 1048 is to the right of 980 and 1081 is to the right of 1048, we have

$$\begin{array}{rcccl} 980 & < & 1048 & < & 1081 \\ \text{Fresno} & & \text{Miami} & & \text{Phoenix} \end{array}$$

b. The city with the smallest number of auto thefts is Fresno.

B > Rounding Whole Numbers

When finding the length of a paper clip, we might be told to **round** the answer to the nearest inch. In this case, the length is 2 inches. One use of **rounding numbers** is in dealing with very large numbers (such as the amount owed by the U.S. government in a recent year, \$6409 billion) or where the numbers change so fast that it is not possible to give an exact figure (for example, the population of a certain city might be about 250,000), or when estimating answers in solving problems.

To **round** a number, we specify the **place** value to which we are to round and underline it. Thus, when rounding 78 to the nearest ten, we write

$$\begin{array}{c} \underline{7} \ 8 \\ \uparrow \\ \text{Tens place} \end{array}$$

On the number line, this means we count by tens and find the group of tens closest to 78, which is 80, as shown in Figure 1.4.

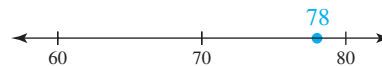

>Figure 1.4

When rounding 813 to the nearest hundred, write

$$\begin{array}{c} \underline{8} \ 1 \ 3 \\ \uparrow \\ \text{Hundreds place} \end{array}$$

and use a number line with intervals of 100. You can see that 813 is closest to 800, as indicated in Figure 1.5.

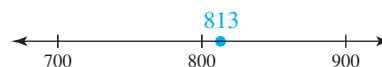

>Figure 1.5

When rounding 3500 to the nearest thousand, write

$$\begin{array}{c} \underline{3} \ 5 \ 0 \ 0 \\ \uparrow \\ \text{Thousands place} \end{array}$$

and use a number line with intervals of 1000. You can see that 3500 lies exactly in between 3000 and 4000, as shown in Figure 1.6.



>Figure 1.6

To do the actual **rounding**, we use the following rule:

RULE FOR ROUNDING WHOLE NUMBERS*

- Step 1.** *Underline* the place to which you are rounding.
- Step 2.** If the first digit to the *right* of the underlined place is 5 or more, *add one* to the underlined digit. Otherwise *do not change* the underlined digit.
- Step 3.** *Change* all the digits to the *right* of the underlined digit to zeros.

Thus, to round 78 to the nearest ten, we use the three steps given.

- Step 1.** Underline the place to which we are rounding.
- Step 2.** If the first digit to the right of the underlined place (the 8) is 5 or more, add one to the underlined digit.
- Step 3.** The digit to the right of the underlined digit becomes zero.
- $$\begin{array}{c} \underline{7} \quad 8 \\ + 1 \\ \hline 8 \quad 0 \end{array}$$

Tens place

The number to the right of the 7 is more than 5, so we add one to the 7 and get 8.
- $$\begin{array}{c} 8 \quad 0 \\ \uparrow \end{array}$$

The 8 becomes a zero.

We write the answer like this: $\underline{7}8 \approx 80$. Thus, 78 rounded to the nearest 10 is 80. (See Figure 1.4.)

EXAMPLE 3 Rounding whole numbers

Round 813 to the nearest hundred.

SOLUTION 3

- Step 1.** Underline the place to which we are rounding. $\underline{8} \quad 1 \quad 3$
- Step 2.** The first digit to the right of 8 is 1, so we do not change the underlined digit. $\underline{8} \quad 1 \quad 3$
- Step 3.** We then change all the digits to the right of the underlined digit to zeros. $\underline{8} \quad 0 \quad 0$

We then have $\underline{8}13 \approx 800$. Thus, 813 rounded to the nearest hundred is 800. (See Figure 1.5.)

PROBLEM 3

Round 347 to the nearest hundred.

EXAMPLE 4 Rounding whole numbers

Round 3500 to the nearest thousand.

SOLUTION 4

- Step 1.** Underline the place to which we are rounding. $\underline{3}500$

PROBLEM 4

Round 6508 to the nearest thousand.

* Some textbooks round a number ending in 5 so that the last retained digit is even.

Answers to PROBLEMS

3. $\underline{3}47 \approx 300$ 4. $\underline{6}508 \approx 7000$

Step 2. The first digit to the right of the underlined digit is 5, so we add one to the underlined digit (obtaining 4). $\underline{4}500$

Step 3. Change all the digits to the right of the underlined digit to zeros. $\underline{4}000$

Thus, $\underline{3}500 \approx 4000$ so that 3500 rounded to the nearest thousand is 4000. (See Figure 1.6.)

C > Applications Involving Whole Numbers

EXAMPLE 5 Rounding whole numbers

A planner estimated that on an average day 1,169,863 persons take a taxi. Round this number to the nearest thousand.

SOLUTION 5

Step 1. Underline the place to which we are rounding. $1,16\underline{9},863$

Step 2. The first digit to the right of the underlined digit is 8 (more than 5), so we add one to the 9, obtaining 10, and write the answer on the next line. You can also think of this as adding 1 to 69 and getting 70 on the next line. $1,16\underline{10},863$
 $1,170,863$

Step 3. Change all the digits to the right of the underlined digit to zeros. $1,170,000$

We then have $1,169,863 \approx 1,170,000$, which means that 1,169,863 rounded to the nearest thousand is 1,170,000.

PROBLEM 5

On an average day 6375 couples wed in the United States. Round this number to the nearest thousand.

Source: U.S. Census Bureau.

Sometimes the same number is rounded to different places. For example, on an average day 231,232,876 eggs are laid (honest!). This number can be rounded to

The nearest *hundred* $231,232,\underline{8}76 \approx 231,232,900$

The nearest *thousand* $231,232,\underline{8}76 \approx 231,233,000$

The nearest *million* $231,\underline{2}32,876 \approx 231,000,000$

We use this idea in Example 6, which should be of interest to you.

EXAMPLE 6 Rounding whole numbers

It has been estimated that by retirement age a high school graduate will outearn a non-high school graduate by \$405,648. Round this number to

- the nearest hundred.
- the nearest thousand.
- the nearest ten thousand.

SOLUTION 6

a. Step 1. $405,\underline{6}48$

↑
Underline the 6 (the hundreds place).

PROBLEM 6

A college graduate will outearn a high school graduate by \$1,013,088. Round this number to

- the nearest hundred.
- the nearest thousand.
- the nearest ten thousand.

(continued)

Answers to PROBLEMS

5. $\underline{6}375 \approx 6000$ 6. a. \$1,013,100 b. \$1,013,000 c. 1,010,000

Step 2. 405,648

Four is less than 5.
Leave the 6 as is.

Step 3. 405,600

Change to zeros.

Thus, 405,648 rounded to the nearest hundred is 405,600.

b. Step 1. 405,648

Underline the 5 (the thousands place).

Step 2. 406,648

Six is more than 5 (add 1 to the 5).
 $5 + 1 = 6$

Step 3. 406,000

Change to zeros.

Thus, 405,648 rounded to the nearest thousand is 406,000.

c. Step 1. 405,648

Underline the zero (the ten thousands place).

Step 2. 415,648

Five is equal to 5 (add 1 to the 0).
 $0 + 1 = 1$

Step 3. 410,000

Change to zeros.

Thus, 405,648 rounded to the nearest ten thousand is 410,000.

EXAMPLE 7 Rounding whole numbers

In 2009, the best-selling car in America was the Toyota Camry. Use the chart (page 19) to round the specified prices. Suppose you have a \$22,000 budget.

- Round the True Market Value (TMV) Base Price to the nearest hundred.
- Round the TMV price of the GJ package #3 to the nearest hundred.
- Round the TMV price of the BE package to the nearest hundred.

SOLUTION 7

- The base price is \$20,080. To round \$20,080 to the nearest hundred, underline the hundreds place, that is, the 0. Since the 8 to the right of 0 is more than 5, add one to the 0, write 1, and change the last two numbers to zeros to get the estimate \$20,100 as shown.
- The GJ package costs \$1475. Underline the hundreds place, that is, the 4. Since the 7 to the right of 4 is more than 5, add one to the 4, write 5, and add two zeros at the end to get the estimate, \$1500.
- The BE package is \$438. Underline the 4. Since the 3 to the right of the 4 is less than 5, leave the 4 alone and add two zeros at the end to get the estimate, \$400.

PROBLEM 7

Estimate, to the nearest hundred, the TMV price of

- the GU package.
- the SR package.
- the XV package.

Answers to PROBLEMS

7. a. \$1000 b. \$700 c. \$100

PRICE WITH OPTIONS

Add Options to this Toyota Camry LE V6 4dr Sedan (3.0L 6cyl 6A)						
	MSRP	Invoice	TMV True Market Value® Pricing	Estimate		
 <u>Regional Base Price</u>	\$22,260	\$19,810	\$20,080	\$20,100		
STEP 1 Add Options						
Add	Code	Option Name	MSRP	Invoice	TMV True Market Value® Pricing	Estimate
<input type="checkbox"/>	GJ	Package #3 info	\$1,820	\$1,432	\$1,475	\$1500
<input type="checkbox"/>	GU	VSC & Side Airbag Package info	\$1,150	\$950	\$972	
<input type="checkbox"/>	SR	Power Moonroof info	\$900	\$720	\$740	
<input type="checkbox"/>	GI	Package #2 info	\$630	\$490	\$505	
<input type="checkbox"/>	BE	Front Side & Curtain Airbags info	\$500	\$430	\$438	\$400
<input type="checkbox"/>	EJ	JBL 3-in-1 Premium Combo w/Changer info	\$490	\$368	\$381	
<input type="checkbox"/>	XV	Adjustable Power Accelerator Pedal Info	\$120	\$96	\$99	

By the way, the estimate comes to exactly \$22,000.

How does your car pollution compare to the pollution from your mower? We shall see in Example 8.

GREEN MATH

EXAMPLE 8 Air pollution from your mower and your car

According to the U.S. Environmental Protection Agency (EPA), a traditional gas-powered lawn mower produces as much air pollution as 43 new cars being driven 12,000 miles each. Round 43 to the nearest 10.

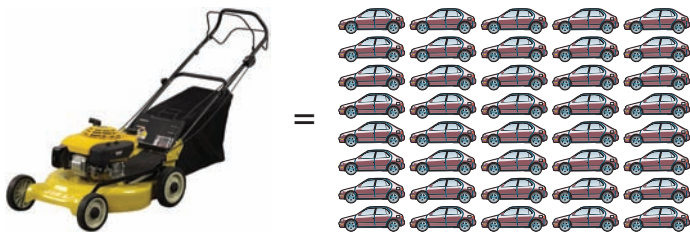

- SOLUTION 8**
- Step 1.** Underline the tens place, 43.
 - Step 2.** The number to the right of the underlined digit is 3, so we do not change the underlined digit 4.
 - Step 3.** Change all numbers to the right of 4 to 0's. Thus, 43 rounded to the nearest 10 is 40, that is, $43 \approx 40$.

Do you see how the artist/designer used rounding to create the graph?

Source: <http://www.peoplepoweredmachines.com/faq-environment.htm>.

PROBLEM 8

Round 12,000 to the nearest ten thousand.

Answers to PROBLEMS

8. 10,000



> Practice Problems > Self-Tests
> Media-rich eBooks > e-Professors > Videos

> Exercises 1.2

< A > Ordering Numbers In Problems 1–10, fill in the blank with $<$ or $>$ to make a true inequality.

- | | | | |
|----------------------------------|-----------------------------------|--------------------------------|--------------------------------|
| 1. $8 \underline{\quad} 10$ | 2. $6 \underline{\quad} 16$ | 3. $8 \underline{\quad} 0$ | 4. $0 \underline{\quad} 10$ |
| 5. $102 \underline{\quad} 120$ | 6. $808 \underline{\quad} 880$ | 7. $999 \underline{\quad} 990$ | 8. $777 \underline{\quad} 770$ |
| 9. $1001 \underline{\quad} 1010$ | 10. $2002 \underline{\quad} 2020$ | | |

< B > Rounding Whole Numbers In Problems 11–30, round to the underlined place.

- | | | | |
|------------------|------------------|------------------|------------------|
| 11. <u>7</u> 3 | 12. <u>8</u> 4 | 13. <u>8</u> 6 | 14. <u>4</u> 7 |
| 15. <u>9</u> 8 | 16. <u>9</u> 7 | 17. <u>1</u> 03 | 18. <u>2</u> 04 |
| 19. <u>3</u> 86 | 20. <u>4</u> 76 | 21. <u>9</u> 50 | 22. <u>9</u> 63 |
| 23. <u>2</u> 308 | 24. <u>6</u> 209 | 25. <u>6</u> 999 | 26. <u>8</u> 999 |
| 27. <u>9</u> 999 | 28. <u>9</u> 990 | 29. <u>9</u> 099 | 30. <u>9</u> 011 |

In Problems 31–40, round the given number to the nearest ten, the nearest hundred, and the nearest thousand.

	Ten	Hundred	Thousand
31. 586	_____	_____	_____
32. 650	_____	_____	_____
33. 29,450	_____	_____	_____
34. 39,990	_____	_____	_____
35. 49,992	_____	_____	_____
36. 349,908	_____	_____	_____
37. 259,906	_____	_____	_____
38. 349,904	_____	_____	_____
39. 289,000	_____	_____	_____
40. 999,000	_____	_____	_____

< C > Applications Involving Whole Numbers

- | | |
|---|---|
| <p>41. <i>Rapid typing</i> The record for rapid typing with a standard typewriter is held by Albert Tagora. On October 23, 1923, he typed an average of 147 words a minute. Round 147 to the nearest ten.</p> <p>43. <i>Weight loss</i> Do you have a weight problem? The heaviest man on record was Robert Earl Hughes, who tipped the scales at 1069 pounds. Round 1069 to the nearest hundred.</p> <p>45. <i>Really smoking!</i> If you smoke $1\frac{1}{2}$ packs of cigarettes a day, you will smoke about 10,950 cigarettes a year. Round 10,950 to the nearest thousand.</p> <p>47. <i>New York population</i> According to a recent census, the number of people in New York City is 7,895,563. Round this number to the nearest one hundred thousand.</p> | <p>42. <i>Fishing</i> Have you gone fishing lately? The largest fish ever caught by rod and reel was a white shark weighing 2664 pounds. Round 2664 to the nearest ten.</p> <p>44. <i>Heavy lifting</i> The heaviest weight ever lifted by a human being was 6270 pounds, lifted by Paul Anderson in 1957. Round 6270 to the nearest hundred.</p> <p>46. <i>Hertz used cars</i> A survey conducted by Hertz shows that the typical used car purchased in a certain year showed 29,090 miles on the odometer. Round 29,090 to the nearest thousand.</p> <p>48. <i>Population of Nevada</i> The number of residents of Nevada was counted and found to be 2,070,000. Round this number to the nearest one hundred thousand.</p> |
|---|---|

- 49. Godfather money!** Did you see the movie *The Godfather*? A lot of people did! In fact, during its first three years in circulation the movie made \$85,747,184. Round this number to the nearest million.
- 51. Cheap as Dell** Here are the prices for three Dell computer models.
Use an inequality to compare the prices:
- From lowest to highest
 - From highest to lowest
 - Which is the most expensive model?
 - Which is the least expensive model?
- 50. Movie revenue** *The Sound of Music* is another famous movie. In its first ten years it made \$83,891,000. Round this number to the nearest million.
- 52. Price of Gateways** Here are the prices for three Gateway computer models.
Use an inequality to compare the prices:
- From lowest to highest
 - From highest to lowest
 - Which is the most expensive model?
 - Which is the least expensive model?

Cutting Edge	Performance	Affordability
Dimension 8400 from \$1019	Dimension E310 from \$689	Dimension F510 from \$968

Feature Rich	High Performance	Value
Gateway GM 5072 starting at \$1299	Gateway GT 5058 starting at \$899	Gateway GT 4016 starting at \$449

>>> Applications: Green Math

Saving money in your electric bill

Strategy	Up-Front Cost	Savings per Year
Replace regular light bulbs with compact fluorescents	\$32	\$90
Wash laundry in cold water instead of hot or warm	\$0	\$167
Use a clothesline or a laundry rack instead of a dryer	\$20	\$141
Turn off a single 100-watt lightbulb from running constantly	\$0	\$96

- 53.** Use an inequality to arrange the **savings per year** (last column):
- From lowest to highest
 - From highest to lowest
 - Which strategy saves the most money?
 - Which strategy saves the least money?

Strategy	Up-Front Cost	Savings per Year
Replace top-loading washer with front-loading washer	\$500	\$90
Replace 1990 fridge with 2009 model	\$300	\$45
Replace a CRT computer monitor in a home office with an LCD display	\$200	\$21

- 54.** Use an inequality to arrange the **up-front costs**:
- From lowest to highest
 - From highest to lowest
 - Which is the most expensive strategy?
 - Which is the least expensive strategy?

Source: <http://michaelbluejay.com/electricity/laundry.html>.

>>> Using Your Knowledge

Here is an activity that you cannot evade: filing your income tax return. The U.S. government has a booklet called Publication 796 to help you do it! This publication states:

All money items appearing on your return may be rounded off to **whole dollars** on your returns and schedules, provided you do so for all entries on the return.

Use the knowledge you have obtained in this section to round off the numbers in the following form.

Income	7	Wages, salaries, tips, etc. Attach Form(s) W-2	7	23,899	56	55.
	8a	Taxable interest. Attach Schedule B if required	8a	39	06	56.
Attach Forms W-2 and W-2G here. Also attach Form(s) 1099-R if tax was withheld.	b	Tax-exempt interest. Do not include on line 8a	8b			
	9a	Ordinary dividends. Attach Schedule B if required	9a			
If you did not get a W-2, see page 22.	b	Qualified dividends (see page 23)	9b			
	10	Taxable refunds, credits, or offsets of state and local income taxes (see page 23)	10			
Enclose, but do not attach, any payment. Also, please use Form 1040-V.	11	Alimony received	11			
	12	Business income or (loss). Attach Schedule C or C-EZ	12	349	48	57.
	13a	Capital gain or (loss). Attach Schedule D if required. If not required, check here <input type="checkbox"/>	13a			
	b	If box on 13a is checked, enter post-May 5 capital gain distributions	13b			
	14	Other gains or (losses). Attach Form 4797	14			
	15a	IRA distributions	15a			
	b	Taxable amount (see page 25)	15b			
	16a	Pensions and annuities	16a	1,387	53	58.
	b	Taxable amount (see page 25)	16b			
	17	Rental real estate, royalties, partnerships, S corporations, trusts, etc. Attach Schedule E	17			
	18	Farm income or (loss). Attach Schedule F	18			
	19	Unemployment compensation	19			
	20a	Social security benefits	20a			
	b	Taxable amount (see page 27)	20b			
	21	Other income. List type and amount (see page 27)	21			
	22	Add the amounts in the far right column for lines 7 through 21. This is your total income	22	25,675	63	59.

Write On

- 60. Write in your own words the procedure you will use to round a number when the digit to the right of the place to which you are rounding is less than 5.
- 61. Write in your own words the procedure you will use to round a number when the digit to the right of the place to which you are rounding is 5 or more.
- 62. Can you think of three situations in which estimating can be useful?

Concept Checker

Fill in the blank(s) with the correct word(s), phrase, or mathematical statement.

- 63. $a < b$ means that a is to the _____ of b on the number line.
- 64. If a is to the right of b on the number line, a _____ b .
- 65. To **round** a number, we specify the _____ to which we are to round.
- 66. The first step in the **rule** for rounding whole numbers is to _____ the place to which we are rounding.
- 67. When rounding the number $\nabla \square$ to the nearest **ten**, if the number in the \square box is 5 or more, _____ to ∇ .
- 68. $a < b$ and $b > a$ are examples of _____.

- < right
- left inequalities
- place delete
- add one >
- underline rounding

Mastery Test

- 69. Round to the underlined place:
 - a. 765
 - b. 364
 - c. 862
- 70. Fill in the blank with $<$ or $>$ to make the resulting inequalities true.
 - a. 349 _____ 399
 - b. 57 _____ 27
 - c. 1000 _____ 999
 - d. 1099 _____ 1199
- 71. The median income of an MTV median household is \$49,773. Round \$49,773 to the nearest thousand.

Source: Nielsen Media Research.
- 72. The highest domestic gross receipts for a movie are from *Avatar*. The domestic gross ticket receipts (in millions) of five other movies listed alphabetically are as follows:
 - E.T., \$435
 - Spider-Man, \$404
 - Star Wars, \$461
 - Star Wars: The Phantom Menace, \$431
 - Titanic, \$601
 - a. List the *amounts* of ticket receipts from highest to lowest using inequalities.
 - b. List the *amounts* of ticket receipts from lowest to highest using inequalities.

>>> Skill Checker

What kind of car do you drive? Here are the six least-expensive cars in a recent year. Write the numerals in words.

- 73. Chevrolet Aveo, \$9995
- 74. Kia Rio, \$10,280
- 75. Hyundai Accent, \$10,544
- 76. Chevrolet Cavalier, \$10,890
- 77. Toyota Echo, \$10,995
- 78. Pontiac Sunfire, \$11,460

Source: Data for Exercises 73–78 from Edmunds.com, <http://www.edmunds.com>.

h

1.3

Addition

▶ Objectives

You should be able to:

- A > Add two or more whole numbers, regrouping (carrying) if necessary.
- B > Use addition to find perimeters of polygons.

▶ To Succeed, Review How To . . .

Use the addition facts in the table on page 24.

▶ Getting Started



Configuration	Invoice	MSRP
Base Model	\$19,810	\$22,260
Destination	\$485	\$485

What is the invoice price for the car? To find out, we have to *add* the Base Model Price (\$19,810) and the Destination charge (\$485). To answer the question “how many?” we use the set of *whole numbers* 0, 1, 2, 3, . . . , and the operation of **addition**.

A > Adding Two or More Whole Numbers

Addition can be explained by counting. For example, the sum

$$6 + 2$$

can be found by using a set of 6 objects and another set of 2 objects, putting them together, and counting all the objects, as shown:

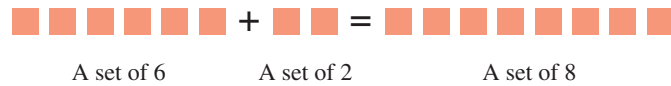

The numbers to be added, in this case 6 and 2, are called **addends**, and the result 8 is called the **sum**, or **total**. The procedure is usually written as

$$\begin{array}{r} 6 \\ +2 \\ \hline 8 \end{array}$$

← addend
← addend
← sum

where we have used the plus (+) sign to indicate addition. All the addition facts you need are in the table, but you either know these facts already, or should take the time to memorize them now!

ADD (+)	0	1	2	3	4	5	6	7	8	9
0	0	1	2	3	4	5	6	7	8	9
1	1	2	3	4	5	6	7	8	9	10
2	2	3	4	5	6	7	8	9	10	11
3	3	4	5	6	7	8	9	10	11	12
4	4	5	6	7	8	9	10	11	12	13
5	5	6	7	8	9	10	11	12	13	14
6	6	7	8	9	10	11	12	13	14	15
7	7	8	9	10	11	12	13	14	15	16
8	8	9	10	11	12	13	14	15	16	17
9	9	10	11	12	13	14	15	16	17	18

Zero is called the **identity** for addition.

IDENTITY FOR ADDITION

Any number a added to zero equals the number; that is, adding 0 to a number does not change the number.

$$a + 0 = a = 0 + a$$

Also, the order in which two numbers a and b are added is not important. This is called the **commutative property of addition**. Thus, $3 + 2 = 2 + 3$ and $5 + 7 = 7 + 5$. In general,

COMMUTATIVE PROPERTY OF ADDITION

Changing the order of two addends does not change their sum.

$$a + b = b + a$$

After you do the examples, you will see that the invoice price will be \$20,295.

Now let us try another problem:

$$\text{Add: } 46 + 52 = \underline{\quad}$$

Before adding, we note that the answer, to the nearest ten, should be $50 + 50$, or about 100. This kind of approximation, or **estimation**, can give a valuable check on the answer. We then write the problem like this:

$$\begin{array}{r} \text{tens column} \quad \text{ones column} \\ 46 \\ + 52 \\ \hline \end{array}$$

Note that the numbers have been arranged vertically in columns with the ones digits in the ones column and the tens digits in the tens column. We then add the ones first, then the tens, and so on. The short form of the addition is on the left, and the expanded form appears on the right.

Short Form	Expanded Form
$\begin{array}{r} 46 \\ + 52 \\ \hline 98 \end{array}$	$\begin{array}{r} 40 + 6 \\ + 50 + 2 \\ \hline 90 + 8 = 98 \end{array}$
<div style="border: 1px solid orange; padding: 2px; display: inline-block;">add tens</div>	<div style="border: 1px solid orange; padding: 2px; display: inline-block;">add ones first</div>

In this case, if the actual answer (98) is rounded to the nearest ten, we obtain our estimated answer (100).

Our estimate (100) is near the actual answer (98).

EXAMPLE 1 Adding whole numbers

Add $42 + 53$.

SOLUTION 1

$$\begin{array}{r} 42 \\ + 53 \\ \hline 95 \end{array}$$

Step 1. Estimate the answer. To the nearest ten, it will be

$$40 + 50 = 90.$$

Step 2. Arrange in columns.

Step 3. Add ones.

Step 4. Add tens.

Note that the actual answer (95) is near our estimate (90).

PROBLEM 1

Add $45 + 32$.

EXAMPLE 2 Adding whole numbers

Add $341 + 235$.

SOLUTION 2

$$\begin{array}{r} 341 \\ + 235 \\ \hline 576 \end{array}$$

Step 1. Estimate the answer: $340 + 240 = 580$.

Step 2. Arrange in columns.

Step 3. Add ones.

Step 4. Add tens.

Step 5. Add hundreds.

The answer (576) is close to our estimate (580).

PROBLEM 2

Add $236 + 741$.

Answers to PROBLEMS

1. 77 2. 977

Here is another problem: $56 + 38 = \underline{\hspace{2cm}}$. Compare the expanded form and the short form.

Short Form	Expanded Form
$\begin{array}{r} 1 \\ 56 \\ + 38 \\ \hline 94 \end{array}$	$\begin{array}{r} 50 + 6 \\ + 30 + 8 \\ \hline 80 + 14 = 80 + 10 + 4 \\ = 90 + 4 \\ = 94 \end{array}$

Note that the 1 “carried” over to the tens column is really a 10. The 14 is rewritten as $10 + 4$. Here is another way of showing this:

Step 1	Step 2	Step 3
$\begin{array}{r} 56 \\ + 38 \\ \hline 14 \end{array}$ <p style="text-align: center;">Add ones ($6 + 8 = 14$).</p>	$\begin{array}{r} 56 \\ + 38 \\ \hline 14 \\ 80 \end{array}$ <p style="text-align: center;">Add tens ($50 + 30 = 80$).</p>	$\begin{array}{r} 56 \\ + 38 \\ \hline 14 \\ 80 \\ \hline 94 \end{array}$ <p style="text-align: center;">Add partial sums ($14 + 80 = 94$).</p>

The 1 we “carry” is the 1 in 14. (*Note:* You should do your addition using the short form to save time.)

EXAMPLE 3 Adding whole numbers

Add $537 + 48$.

SOLUTION 3

$$\begin{array}{r} 1 \\ 537 \\ + 48 \\ \hline 585 \end{array}$$

Step 1. Estimate the answer: $540 + 50 = 590$.

Step 2. Arrange in columns.

Step 3. Add ones. Remember to carry 1: ($7 + 8 = 15$)

Step 4. Add tens.

Step 5. Add hundreds.

Our estimate (590) is close to the answer (585).

PROBLEM 3

Add $243 + 29$.

EXAMPLE 4 Adding whole numbers

Add $354 + 261$.

SOLUTION 4

$$\begin{array}{r} 1 \\ 354 \\ + 261 \\ \hline 615 \end{array}$$

Step 1. The estimated answer is $350 + 260 = 610$.

Step 2. Arrange in columns.

Step 3. Add ones.

Step 4. Add tens. Remember to carry 1: ($5 + 6 = 11$)

Step 5. Add hundreds.

Our estimate (610) is close to the answer (615).

PROBLEM 4

Add $263 + 475$.

Answers to PROBLEMS

3. 272 4. 738

EXAMPLE 5 Adding whole numbersAdd $823 + 746$.**SOLUTION 5**

$$\begin{array}{r} 823 \\ + 746 \\ \hline 1569 \end{array}$$

Step 1. The estimated answer is $820 + 750 = 1570$.**Step 2.** Arrange in columns.**Step 3.** Add ones.**Step 4.** Add tens.**Step 5.** Add hundreds.

The estimated answer (1570) is close to the answer (1569).

PROBLEM 5Add $632 + 754$.**EXAMPLE 6** Adding whole numbersAdd $704 + 5642$.**SOLUTION 6**

$$\begin{array}{r} 1 \\ 704 \\ + 5642 \\ \hline 6346 \end{array}$$

Step 1. To the nearest hundred, the estimate is $700 + 5600 = 6300$. (You could estimate the answer to the nearest ten, but such an estimate is as involved as the original problem.)**Step 2.** Arrange in columns.**Step 3.** Add ones.**Step 4.** Add tens.**Step 5.** Add hundreds. Remember to carry 1: ($7 + 6 = \underline{13}$)**Step 6.** Add thousands.

Our estimate (6300) is close to the answer (6346).

PROBLEM 6Add $813 + 1702$.**EXAMPLE 7** Adding whole numbersAdd $5471 + 2842$.**SOLUTION 7**

$$\begin{array}{r} 11 \\ 5471 \\ + 2842 \\ \hline 8313 \end{array}$$

Step 1. To the nearest thousand, the estimate is $5000 + 3000 = 8000$.**Step 2.** Arrange in columns.**Step 3.** Add ones.**Step 4.** Add tens. Remember to carry 1: ($7 + 4 = \underline{11}$)**Step 5.** Add hundreds. Remember to carry 1: ($1 + 4 + 8 = \underline{13}$)**Step 6.** Add thousands.

Note that our estimate (8000) is close to the actual answer (8313).

PROBLEM 7Add $3943 + 4672$.

Sometimes it is necessary to add more than two numbers. The procedure is similar to the one explained previously. For example, to do the addition

$$4272 + 2367 + 7489 + 1273$$

Answers to PROBLEMS

5. 1386 6. 2515 7. 8615

we proceed as follows:

$$\begin{array}{r}
 1\ 3\ 2 \\
 4\ 2\ 7\ 2 \\
 2\ 3\ 6\ 7 \\
 7\ 4\ 8\ 9 \\
 +\ 1\ 2\ 7\ 3 \\
 \hline
 1\ 5\ 4\ 0\ 1
 \end{array}$$

Step 1. To the nearest thousand, our estimate is $4000 + 2000 + 7000 + 1000 = 14,000$.

Step 2. Arrange in columns.

Step 3. $2 + 7 + 9 + 3 = 21$

Step 4. $2 + 7 + 6 + 8 + 7 = 30$

Step 5. $3 + 2 + 3 + 4 + 2 = 14$

Step 6. $1 + 4 + 2 + 7 + 1 = 15$

EXAMPLE 8 Adding whole numbers

Add $1343 + 5632 + 8789 + 7653$.

SOLUTION 8

$$\begin{array}{r}
 221 \\
 1343 \\
 5632 \\
 8789 \\
 +\ 7653 \\
 \hline
 23,417
 \end{array}$$

PROBLEM 8

Add $2451 + 4741 + 7879 + 6563$.

When adding a long list of digits, it is often easier to look for pairs of numbers whose sum is ten or a multiple of ten and add these first. Here is how you do it:

$$\begin{array}{r}
 1\ 3 \\
 4 \\
 7 \\
 6 \\
 +\ 3 \\
 \hline
 3\ 3
 \end{array}$$

EXAMPLE 9 Adding whole numbers

Add $16 + 8 + 4 + 5 + 2$.

SOLUTION 9

$$\begin{array}{r}
 1\ 6 \\
 8 \\
 4 \\
 5 \\
 +\ 2 \\
 \hline
 3\ 5
 \end{array}$$

PROBLEM 9

Add $13 + 6 + 4 + 7 + 8$.

$$\begin{array}{r}
 13 \\
 6 \\
 4 \\
 7 \\
 +\ 8 \\
 \hline
 \end{array}$$

There are many problems that require *addition* for their solution. We give one that may be of interest to you in the next example.

Answers to PROBLEMS

8. 21,634 9. 38

EXAMPLE 10 Tuition costs

How many thousands of dollars will it cost a Florida resident to attend the fall and spring semesters?

Tuition Costs and Fees	Florida Residents Fall & Spring	Out-of-State Residents Fall & Spring
Undergraduate Student		
Full-Time Tuition	\$2700	\$12,240
Room & Board	6450	6450
Books/Supplies	800	800
SUBTOTAL	_____	_____

SOLUTION 10 To find the answer, we first round each of the numbers in the first column (\$2700, \$6450, and \$800) to the nearest thousand and then add the thousands.

$$\begin{array}{r} \underline{2}700 \rightarrow 3000 \\ \underline{6}450 \rightarrow 6000 \\ 800 \rightarrow \underline{1}000 \\ \$10,000 \end{array}$$

Note that we can add 3 and 6 and then 1 like this:

$$(3 + 6) + 1 = 9 + 1 = 10 \quad \text{The parentheses tell us to add 3 and 6 first.}$$

$$\text{or } 3 + (6 + 1) = 3 + 7 = 10 \quad \text{Same answer}$$

This is an illustration of the associative property of addition. It tells us that it does not matter how we group the numbers, the answer is the same.

PROBLEM 10

How many thousands of dollars will it cost an out-of-state resident to attend the fall and spring semesters?



GREEN MATH

EXAMPLE 11 Things you can do to save gas and money:

Action	Gallons Saved per Year	Cost (\$3.40/gallon)
Drive less aggressively	125	\$425
Keep engine tuned	165	\$561
Combine trips (cut 20 miles per week)	52	\$177

How many total gallons can you save per year?

SOLUTION 11 Add the numbers in the first column.

$$\begin{array}{r} 11 \\ 125 \\ 165 \\ \underline{52} \\ 342 \end{array}$$

Step 1. Estimate the answer ($100 + 200 + 50 = 350$).

Step 2. Arrange in columns.

Step 3. Add the ones ($5 + 5 + 2 = 12$, carry 1).

Step 4. Add the tens ($1 + 2 + 6 + 5 = 14$, carry 1).

Step 5. Add the hundreds ($1 + 1 + 1 = 3$).

Note that the answer 342 is close to the estimate 350.

Source: <http://www.fightglobalwarming.com/>.

PROBLEM 11

In the table in Example 11, find the yearly cost by adding the numbers in the last column.

Answers to PROBLEMS

10. \$19,000 11. \$1163

**ASSOCIATIVE
PROPERTY OF
ADDITION**

The grouping of numbers (addends) does not change the final answer (sum).

$$(a + b) + c = a + (b + c)$$

B > Perimeter of Polygons

A **polygon** is a flat geometric figure with many sides. Some examples of polygons are triangles, squares, rectangles, and pentagons.

The associative law can be used to find the *perimeter* of polygons. What is the perimeter? Here is the definition:

PERIMETER

The **distance** around an object is its *perimeter*.

The perimeter of a **polygon** is the sum of the length of all sides.

EXAMPLE 12 Perimeter of a triangle

Find the perimeter of the triangle (in. means inches).

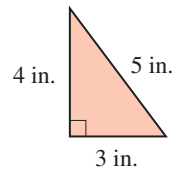

SOLUTION 12 You can add the length of sides 4 and 3 first, and then add 5, that is,

$$(4 + 3) + 5 = 7 + 5 = 12 \text{ inches}$$

or $4 + (3 + 5) = 4 + 8 = 12 \text{ inches}$

Because of the associative property, the answer is the same.

PROBLEM 12

Find the perimeter of the triangle (mi means miles).

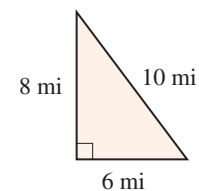
**Calculator Corner**

To add numbers on a calculator with algebraic logic, you can **key** in the problem by pressing the appropriate keys. For example, to do the problem

$$\begin{array}{r} 6 \\ +8 \\ \hline \end{array}$$

you simply press **6** **+** **8** **ENTER**. The display will give the correct answer, 14. If more than two numbers are to be added, the procedure is similar. For example, to obtain the answer for Problem 51, we proceed as follows:

1 **1** **+** **6** **5** **+** **2** **0** **1** **+** **3** **0** **5** **ENTER**

The display will give the correct answer, 582.

Answers to PROBLEMS

12. 24 mi

> Exercises 1.3



> Practice Problems > Self-Tests
> Media-rich eBooks > e-Professors > Videos

< A > Adding Two or More Whole Numbers In Problems 1–50, add.

$$\begin{array}{r} 1. \quad 8 \\ +3 \\ \hline \end{array}$$

$$\begin{array}{r} 2. \quad 6 \\ +4 \\ \hline \end{array}$$

$$\begin{array}{r} 3. \quad 4 \\ +7 \\ \hline \end{array}$$

$$\begin{array}{r} 4. \quad 0 \\ +6 \\ \hline \end{array}$$

$$\begin{array}{r} 5. \quad 4 \\ \quad 6 \\ +6 \\ \hline \end{array}$$

$$\begin{array}{r} 6. \quad 5 \\ \quad 5 \\ +0 \\ \hline \end{array}$$

$$\begin{array}{r} 7. \quad 10 \\ +20 \\ \hline \end{array}$$

$$\begin{array}{r} 8. \quad 30 \\ +30 \\ \hline \end{array}$$

$$\begin{array}{r} 9. \quad 82 \\ +83 \\ \hline \end{array}$$

$$\begin{array}{r} 10. \quad 71 \\ +65 \\ \hline \end{array}$$

$$\begin{array}{r} 11. \quad 4 \\ \quad 53 \\ +72 \\ \hline \end{array}$$

$$\begin{array}{r} 12. \quad 5 \\ \quad 93 \\ +91 \\ \hline \end{array}$$

$$13. \quad 9 + 51$$

$$14. \quad 7 + 33$$

$$15. \quad 0 + 11$$

$$16. \quad 7 + 71$$

$$17. \quad 28 + 6$$

$$18. \quad 32 + 0$$

$$19. \quad 26 + 9$$

$$20. \quad 39 + 7$$

$$\begin{array}{r} 21. \quad 4 \\ \quad 13 \\ + 6 \\ \hline \end{array}$$

$$\begin{array}{r} 22. \quad 5 \\ \quad 12 \\ + 5 \\ \hline \end{array}$$

$$\begin{array}{r} 23. \quad 3 \\ \quad 31 \\ +47 \\ \hline \end{array}$$

$$\begin{array}{r} 24. \quad 2 \\ \quad 38 \\ +61 \\ \hline \end{array}$$

$$\begin{array}{r} 25. \quad 21 \\ \quad 19 \\ +87 \\ \hline \end{array}$$

$$\begin{array}{r} 26. \quad 51 \\ \quad 39 \\ +28 \\ \hline \end{array}$$

$$\begin{array}{r} 27. \quad 67 \\ +58 \\ \hline \end{array}$$

$$\begin{array}{r} 28. \quad 65 \\ +25 \\ \hline \end{array}$$

$$\begin{array}{r} 29. \quad 97 \\ +35 \\ \hline \end{array}$$

$$\begin{array}{r} 30. \quad 86 \\ +24 \\ \hline \end{array}$$

$$\begin{array}{r} 31. \quad 85 \\ +67 \\ \hline \end{array}$$

$$\begin{array}{r} 32. \quad 36 \\ +98 \\ \hline \end{array}$$

$$\begin{array}{r} 33. \quad 386 \\ + 14 \\ \hline \end{array}$$

$$\begin{array}{r} 34. \quad 466 \\ + 89 \\ \hline \end{array}$$

$$\begin{array}{r} 35. \quad 6347 \\ + 426 \\ \hline \end{array}$$

$$\begin{array}{r} 36. \quad 7479 \\ + 521 \\ \hline \end{array}$$

$$\begin{array}{r} 37. \quad 432 \\ +1381 \\ \hline \end{array}$$

$$\begin{array}{r} 38. \quad 795 \\ +2160 \\ \hline \end{array}$$

$$\begin{array}{r} 39. \quad 136 \\ +3587 \\ \hline \end{array}$$

$$\begin{array}{r} 40. \quad 384 \\ +4439 \\ \hline \end{array}$$

$$\begin{array}{r} 41. \quad 4605 \\ + 39 \\ \hline \end{array}$$

$$\begin{array}{r} 42. \quad 7807 \\ + 46 \\ \hline \end{array}$$

$$\begin{array}{r} 43. \quad 108 \\ 2134 \\ + 98 \\ \hline \end{array}$$

$$\begin{array}{r} 44. \quad 706 \\ 3629 \\ + 83 \\ \hline \end{array}$$

$$\begin{array}{r} 45. \quad 305 \\ 6312 \\ +8573 \\ \hline \end{array}$$

$$\begin{array}{r} 46. \quad 609 \\ 6205 \\ +9503 \\ \hline \end{array}$$

$$\begin{array}{r} 47. \quad 82,583 \\ + 8692 \\ \hline \end{array}$$

$$\begin{array}{r} 48. \quad 99,989 \\ + 3454 \\ \hline \end{array}$$

$$\begin{array}{r} 49. \quad 63,126 \\ 77,684 \\ +80,000 \\ \hline \end{array}$$

$$\begin{array}{r} 50. \quad 89,137 \\ 60,470 \\ +36,409 \\ \hline \end{array}$$

>>> Applications

- 51. A kettle of descendants** Captain Wilson Kettle, who died on January 25, 1963, left 11 children, 65 grandchildren, 201 great-grandchildren, and 305 great-great-grandchildren. How many descendants did he leave behind at the time of his death?
- 52. Sugar fights** Sugar Ray Robinson had a record that included 175 victories, 6 draws, and 21 losses. How many total fights did he have?
- 53. Recovery efforts** The amounts of materials recovered (in millions of tons) in a recent year are as follows: paper and paperboard, 37; ferrous metals, 5; glass and plastics, 5; yard and other waste, 17. How many millions of tons is that?
- 54. People in plane** A jumbo jet carries 383 passengers and a crew of 9. How many people are there in the plane?

- 55. Milkshake gallons** One of the largest milkshakes ever made started out with 118 gallons of vanilla ice cream, 60 gallons of milk, and 17 gallons of strawberry flavoring. How many gallons of milkshake were mixed in order to make the milkshake?
- 57. Empire State total height** The Empire State Building is 1250 feet tall. The antenna on top of the building is 222 feet tall. How tall is the building with its antenna?
- 59. Gold in a nugget** The purest gold nugget ever found yielded 2248 ounces of pure gold and 32 ounces of impurities. How many ounces did the nugget weigh?
- 56. Bible chapters** In the Judeo-Christian Bible, the Old Testament has 929 chapters and the New Testament has 270. How many total chapters are there in the Judeo-Christian Bible?
- 58. Total calories** A lunch at McDonald's consisted of a Big Mac (570 calories), regular fries (220 calories), a 12-oz Sprite (144 calories), and a hot fudge sundae (357 calories). What is the total number of calories in this lunch?
- 60. Lots of paella!** One of the largest paellas made included 8140 pounds of rice, 6600 pounds of meat, 3300 pounds of mussels, 3080 pounds of beans and peppers, and 440 pounds of garlic. How many pounds of ingredients is that?

>>> Applications: Green Math

Saving energy costs

High Efficiency Appliances Reduce Household Energy Costs

Appliance	Existing	New (NAECA min.)	High-Efficiency Model
Refrigerator/freezers	\$93	\$61	\$24
Clothes washers	\$78	\$70	\$43
Clothes dryers	\$85	\$77	\$71
Dishwashers	\$50	\$40	\$29

Source: www.energystar.gov.

- 61.** Find the annual cost of running the four existing appliances (column 2).
- 62.** Find the annual cost of running the four New National Appliance Energy Conservation Act (NAECA) appliances (column 3).
- 63.** Find the annual cost of running the four high-efficiency model appliances (column 4).
- 64.** Which two high-efficiency models will cost exactly \$100 to run?

< B > Perimeter of Polygons

- 65. Perimeter** How far does a batter have to travel when circling the bases in the major league baseball stadium shown?
- 66. Perimeter of basketball court** What is the perimeter of the standard basketball court shown?

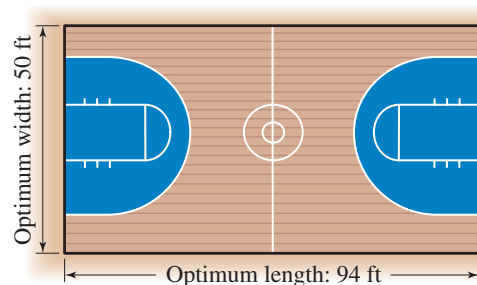
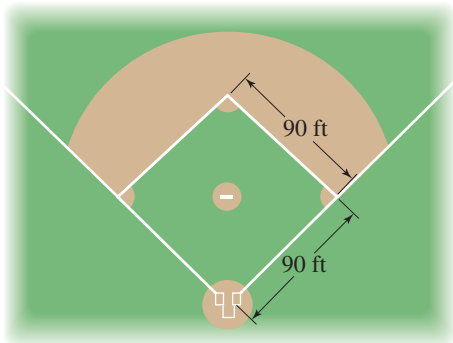

67. *Perimeter of football field* What is the perimeter of the football field?

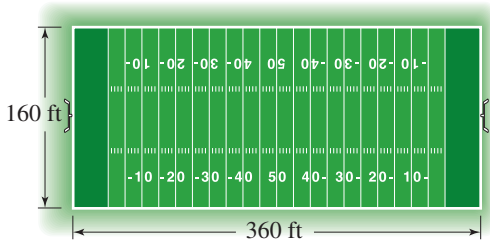

68. *Perimeter of hockey rink* The diagram shows half of a hockey rink. What is the perimeter of the whole rink?

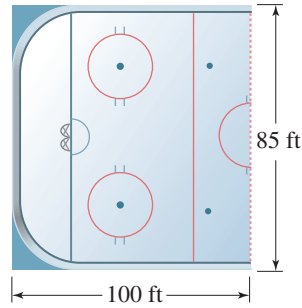

69. *Navajo homes* Do you know what a Hogan is? It is a traditional Navajo home usually built with the entrance facing east. There are two kinds of Hogans: male and female. The modern female Hogan has eight sides and each of the walls is about 8 feet wide. What is the perimeter of a female Hogan?



70. *Perimeter of the Pentagon* The Pentagon is a five-sided building housing the Defense Department. If each of the outside walls is 921 feet long, what is the perimeter of the building?



>>> **Using Your Knowledge**

71. *Deposit slips for savings* Individuals and businesses do banking transactions. A common transaction is to deposit money in a savings account. How much money did this person deposit?

SAVINGS DEPOSIT TICKET 60-8124/7233

NAME Mike Fine

ACCOUNT NUMBER 5225687133

DATE August 24
DEPOSITS MAY NOT BE AVAILABLE FOR IMMEDIATE WITHDRAWAL

CITIZENS BANK OF EAGLE POINT EAGLE POINT, IL 64502

⑆ 7 23360 240 ⑆

<input checked="" type="checkbox"/> CASH	98
COIN	
CHECKS #7	83
#14	93
#17	209
(OR TOTAL FROM OTHER SIDE)	
SUB TOTAL	\$

72. *Deposit slips for checking* Another transaction with a bank is to deposit money in a checking account. How much money did this person deposit?

DEPOSIT TICKET 60-8124/7233 1000821897

DAVE ROSE
124 FLOWERY ROAD
HILL CITY, IL 64715

DATE August 22
DEPOSITS MAY NOT BE AVAILABLE FOR IMMEDIATE WITHDRAWAL

SIGN HERE FOR CASH RECEIVED (IF REQUIRED) *

CITIZENS BANK OF EAGLE POINT EAGLE POINT, IL 64502

⑆ 7 23360 240 ⑆ ⑆ 0008 21897 ⑆ 02

<input checked="" type="checkbox"/> CASH	44
COIN	14
CHECKS #2	138
#8	204
#16	77
(OR TOTAL FROM OTHER SIDE)	
SUB TOTAL	\$

73. A budget is a plan for estimating how your income is to be spent (or saved). Find the estimated weekly expenditures of Family A and Family B:

	Family A	Family B
Housing	\$107	\$258
Food	98	175
Clothing	75	130
Transportation	150	190
Recreation	90	105
Savings	100	150

75. Heart disease is a major cause of death in America. There is a simple test based on a study made in Framingham, Mass., that can tell you your risk of suffering a heart attack or stroke. You can find out by *addition*. The chart giving the risk factors, along with the scores for a certain individual, is shown here. (The person scored 14 points, which means that the total risk of having a heart attack or stroke is average.) Add the scores for A, B, and C to determine the total risk for each.

Risk Factor	Scores
Smoking	0 Nonsmoker 2 Less than 20 cigarettes a day 4 20 cigarettes or more a day
Weight	0 Desirable 2 Up to 10 percent over 4 More than 10 percent over
Systolic blood pressure	0 Less than 120 2 120 to 140 4 Over 140
Cholesterol level	0 Less than 150 2 150 to 250 4 Over 250
Physical activity	0 Regular vigorous exercise 2 Moderate exercise 4 Sedentary
Stress and tension	0 Rarely tense or anxious 2 Feel tense two or three times a day 4 Extremely tense
Total risk	0–4 Low 5–9 Below average 10–14 Average 15–20 High 21–24 Very high

Certain Individual	A	B	C
0	2	4	0
2	0	2	2
2	0	4	2
4	2	2	0
2	4	4	0
<u>4</u>	<u>2</u>	<u>2</u>	<u>2</u>
14			

74. One of the items in the budget is the amount of money spent on transportation. In a recent year the total cost (in cents per mile) of owning and operating different automobiles and vans was as follows:

	Standard	Compact	Passenger Van
Maintenance	6	5	6
Gas and oil	9	8	11
Garage, parking	3	3	3
Insurance	7	4	8
Taxes, license, registration	<u>2</u>	<u>1</u>	<u>2</u>

How many cents per mile does it cost to operate

- A standard car?
 - A compact car?
 - A passenger van?
76. Suppose you want to buy a car. You should start by learning how to read a car invoice, finding out how much the dealer pays for the car, and estimating how much you should offer the dealer. (For a lesson on how to do this and many other tips, go to link 1-3-3 on the Bello website at mhhe.com/bello.)

Using the car dealer example shown here:

- Find the suggested list price.
- Find the total of fees.
- Find the total list price (including options).

Car Dealer Example	
BASE PRICE	\$18,580
Destination Charge	\$435
Floor Mats	\$50
Preferred Value Package	\$2571
SUGGESTED LIST PRICE	<input type="text"/>
EXTRA FEES:	
Sales Promotion Fund	\$100
Dealer Advertising Association	\$484
Holdback	\$371
Dealer Flooring Assistance	\$185
TOTAL OF FEES:	<input type="text"/>
TOTAL LIST PRICE (including options)	<input type="text"/>

77. Do the fees seem reasonable to you? Here is the story (reprinted with permission of Jeff Ostroff and Consumer.Net).

A farmer had been ripped off before by a local car dealer. One day, the car dealer told the farmer he was coming over to buy a cow. The farmer priced that cow with the invoice below:

- Round all prices to the nearest dollar.
- Find the farmer's actual suggested list price and the list price you get by adding the answers in part a.
- Find the actual total list price.
- What is the highest-priced item for the basic cow?
- What is the least expensive item for the basic cow?

Cow Dealer Example

BASIC COW	\$499.95
Shipping and handling	35.75
Extra stomach	79.25
Two-tone exterior	142.10
Produce storage compartment	126.50
Heavy-duty straw chopper	189.60
4 spigot/high output drain system	149.20
Automatic fly swatter	88.50
Genuine cowhide upholstery	179.90
Deluxe dual horns	59.25
Automatic fertilizer attachment	339.40
4 × 4 traction drive assembly	884.16
Pre-delivery wash and comb (Farmer Prep)	69.80
FARMER'S SUGGESTED LIST PRICE	<input type="text"/>
Additional Farmer Markup and hay fees	300.00
TOTAL LIST PRICE (including options)	<input type="text"/>
For a cow that's worth maybe \$2500.	

78. Now that you know how to buy a car, let us see how far we can go with it. The map shows distances between cities (red numbers) in the state of Florida. For instance, the driving distance from Tampa to Orlando is 82 miles and from Orlando to Cocoa is 49 miles.

- Find the driving distance from Tampa to Cocoa via Orlando.
- Find the driving distance from Tampa to Ft. Pierce via Orlando and Cocoa.
- Find the driving distance from Bradenton to Miami via West Palm Beach.
- Find the driving distance from Bradenton to Miami via Ft. Myers and Naples. Is this driving distance shorter than the one obtained in part c?



79. Next, let us travel in California.

- Find the driving distance from San Francisco to Manteca, via Oakland.
- Find the driving distance from Monterey to Los Angeles via San Luis Obispo and Santa Barbara.
- Find another route that takes the same number of miles as the one in part b.



80. a. The roads between Los Angeles, Long Beach, and San Bernardino form a triangle. The perimeter of this triangle is the driving distance for a round-trip from Los Angeles via Long Beach and San Bernardino. What is this perimeter?
b. What is the round-trip distance between Long Beach, San Diego, and San Bernardino?
81. The roads connecting San Bernardino, Indio, Blythe, Needles, Barstow, and back to San Bernardino form a pentagon (a five-sided figure). What is the perimeter of this pentagon?
82. Find a pentagon and its perimeter if you start at San Luis Obispo.

>>> Write On

83. Write in your own words what the identity for addition means.
85. Write in your own words what the associative property of addition means.
86. Tyrone drove from San Luis Obispo to Los Angeles via Santa Barbara, (101 + 96) miles. He then drove 62 more miles to San Bernardino.
- a. Write an expression that illustrates this situation and then find the distance from San Luis Obispo to San Bernardino.
- b. Maria started from San Luis Obispo but first stopped at Santa Barbara, 101 miles. She then drove to San Bernardino via Los Angeles, (96 + 62) miles. Write an expression that illustrates Maria's driving distance.
- c. Which property of addition justifies that the driving distances for Tyrone and Maria are the same?
84. Write in your own words what the commutative property of addition means.
87. The price P of a car is its base price (B) plus destination charges D , that is, $P = B + D$. Tran bought a Nissan in Smyrna, Tennessee, and there was no destination charge.
- a. What is D ?
- b. Fill in the blank in the equation $P = B + \underline{\hspace{2cm}}$.
- c. What property of addition justifies the equation in part **b** is correct?

>>> Concept Checker

Fill in the blank(s) with the correct word(s), phrase, or mathematical statement.

88. The **result** of addition is called the _____.
89. In an addition, the numbers to be **added** are called _____.
90. The fact that $a + b = b + a$ is called the _____ Property of Addition.
91. The **identity** for addition is _____.
92. The Associative Property of Addition states that $a + (b + c) = \underline{\hspace{2cm}}$.
93. The distance around an object is called its _____.

0	$a + (b + c)$
total	Perimeter
$(a + b) + c$	1
addends	area
sum	Associative
Commutative	

>>> Mastery Test

94. Find the perimeter of the triangle.

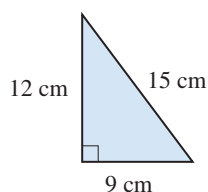

95. Add: $2454 + 6743 + 8789 + 7563$
96. Add: $5374 + 3478 + 8598 + 2382$
97. Add: $712 + 635$
98. Add: $32 + 54$

99. How many thousands of dollars (to the nearest thousand) will it cost a Florida resident to attend the fall and spring semesters?

Fall and Spring Tuition	
Florida Residents	
Tuition/Fees	\$2538
Room	\$3120
Board	\$3330

>>> Skill Checker

100. A Wendy's triple cheeseburger contains 1040 calories, 225 milligrams of cholesterol, and 72 grams of protein.
- Round 1040 to the nearest thousand.
 - Round 225 to the nearest hundred.
 - Round 72 to the nearest ten.
101. Write 1040, 225, and 72 in words.

1.4

Subtraction

▶ Objectives

You should be able to:

A > Subtract one whole number from another, regrouping (borrowing) if necessary.

B > Solve applications involving the concepts studied.

▶ To Succeed, Review How To . . .

- Add two numbers. (p. 24)
- Write a number in expanded form. (p. 4)

▶ Getting Started

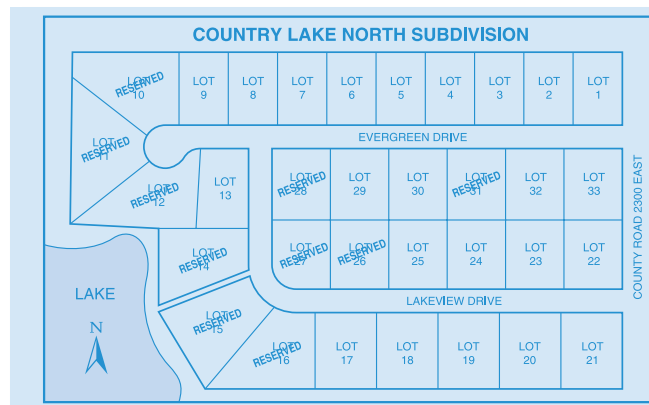

The subdivision has 33 lots and 10 are reserved. How many lots are available? To find the answer, we use the operation of subtraction, indicated by a minus sign ($-$), and write

$$33 - 10 = 23$$

↑
↑

minuend
subtrahend

difference

The procedure is usually written as

tens column	ones column	
3	3	← minuend
- 1	0	← subtrahend
—	2	← difference
	3	

To find how many lots are available you could also think this way: the number reserved is now 10; how many lots have to be reserved before all 33 are reserved? We write

$$10 + \square = 33$$

which means that there is a number \square that added to 10 gives 33. The answer is $\square = 23$.

A > Subtracting Whole Numbers

Here is the definition of subtraction.

SUBTRACTION

The difference $a - b$ is a unique number c so that $a = c + b$

From the discussion in the *Getting Started*, you can see that to subtract whole numbers, we start with two numbers, the **minuend**, which is the larger of the two,* and the **subtrahend**, which is the one being subtracted, and get a third number called the **difference**. As we mentioned, addition and subtraction are related. Thus,

$$7 - 3 = 4 \quad \text{because} \quad 7 = 3 + 4$$

$$8 - 5 = 3 \quad \text{because} \quad 8 = 5 + 3$$

Because addition and subtraction are related (they are *inverse* operations), you can use addition to check your answers in subtraction. For example, you can write

$$\left. \begin{array}{r} 7 \\ -3 \\ \hline 4 \end{array} \right\} \text{and check by adding} \\ 3 + 4 = 7$$

EXAMPLE 1 Subtracting whole numbers

Subtract $13 - 8$.

SOLUTION 1

$$\begin{array}{r} 13 \\ -8 \\ \hline 5 \end{array}$$

CHECK

$$\left. \begin{array}{r} 13 \\ -8 \\ \hline 5 \end{array} \right\} 8 + 5 = 13$$

PROBLEM 1

Subtract $15 - 9$.

Here is another problem:

$$59 - 36 = \underline{\hspace{2cm}}$$

As we did before, we estimate that the answer to the nearest ten should be $60 - 40 = 20$. We then write the problem with the ones and the tens arranged in a column as shown

* Subtractions such as $3 - 7$ and $5 - 8$ are discussed later.

tens column	ones column
↓	↓
5	9
-	3
3	6

As in addition, the numbers were arranged vertically in columns, with the ones digits in the ones column and the tens digits in the tens column. The short form of the subtraction is on the left, and the expanded form is on the right.

Short Form

$$\begin{array}{r} 59 \\ -36 \\ \hline 23 \end{array}$$

Expanded Form

$$\begin{array}{r} 50 + 9 \\ (-)30 + 6 \\ \hline 20 + 3 = 23 \end{array}$$

We can check our work by adding $36 + 23$. Since $36 + 23 = 59$, our answer is correct. Note that our estimate (20) is close to the actual answer (23).

EXAMPLE 2 Subtracting whole numbers

Subtract $86 - 23$.

SOLUTION 2

$$\begin{array}{r} 86 \\ -23 \\ \hline 63 \end{array}$$

Step 1. Estimate the answer, $90 - 20 = 70$.

Step 2. Arrange in columns.

Step 3. Subtract ones. ($6 - 3 = 3$)

Step 4. Subtract tens. ($8 - 2 = 6$)

Remember to check your answer by adding $23 + 63$.

PROBLEM 2

Subtract $95 - 62$.

Now consider the problem

$$\begin{array}{r} 46 \\ -28 \\ \hline \end{array}$$

We cannot subtract 8 from 6 and obtain a whole number, so we have to “borrow” 10 from the 4 (which represents 4 tens, or 40) and think of the 46 (regroup or rewrite) as $30 + 16$. We write

$$\begin{array}{r} (40 - 10 = 30) \rightarrow 3 \ 16 \leftarrow (10 + 6 = 16) \\ \cancel{4} \ 6 \\ -2 \ 8 \\ \hline \end{array}$$

We then subtract 8 from 16 and 2 from 3, as shown. Again, compare the short form and the expanded form.

Short Form

$$\begin{array}{r} 3 \ 16 \\ \cancel{4} \ 6 \\ -2 \ 8 \\ \hline 1 \ 8 \end{array}$$

Expanded Form

$$\begin{array}{r} 30 + 16 \\ (-)20 + 8 \\ \hline 10 + 8 = 18 \end{array}$$

CHECK $28 + 18 = 46$

EXAMPLE 3 Subtracting whole numbers

Subtract $742 - 327$.

SOLUTION 3 To the nearest hundred, the answer should be about $700 - 300 = 400$.

Short Form

$$\begin{array}{r} 3 \ 12 \\ 7 \ \cancel{4} \ \cancel{2} \\ -3 \ 2 \ 7 \\ \hline 4 \ 1 \ 5 \end{array}$$



- Step 1.** Estimate the answer.
- Step 2.** Arrange in columns.
- Step 3.** Write the 42 in 742 as $30 + 12$ (“borrow 1”), as shown.
- Step 4.** Subtract ones.
- Step 5.** Subtract tens.
- Step 6.** Subtract hundreds.

Expanded Form

$$\begin{array}{r} 700 + 30 + 12 \\ (-) 300 + 20 + 7 \\ \hline 400 + 10 + 5 = 415 \end{array}$$

CHECK

$$\begin{array}{r} 327 \\ +415 \\ \hline 742 \end{array}$$

So the result is correct.

PROBLEM 3

Subtract $654 - 239$.

Sometimes, we have to rewrite the number in the hundreds place. For example, to subtract 81 from 346 we proceed as follows:

$$(300 - 100 = 200) \rightarrow 2 \ 14 \leftarrow (100 + 40 = 140)$$

$$\begin{array}{r} \cancel{3} \ \cancel{4} \ 6 \\ -8 \ 1 \\ \hline 2 \ 6 \ 5 \end{array}$$



- Step 1.** Estimate the answer.
- Step 2.** Arrange in columns.
- Step 3.** Subtract ones. ($6 - 1 = 5$)
- Step 4.** Rewrite the 340 in 346 as $200 + 140$ (“borrow 1”), shown as 2 14.
- Step 5.** Subtract tens. ($14 - 8 = 6$)
- Step 6.** Subtract hundreds.

CHECK

$$\begin{array}{r} 1 \\ 81 \\ +265 \\ \hline 346 \end{array}$$

The expanded form for this procedure is

$$\begin{array}{r} 346 \quad 200 + 140 + 6 \\ -81 \quad (-) \quad 80 + 1 \\ \hline 200 + 60 + 5 = 265 \end{array}$$

Answers to PROBLEMS

3. 415

EXAMPLE 4 Subtracting whole numbersSubtract $937 - 53$.**SOLUTION 4**

$$\begin{array}{r} 8\ 13 \\ \cancel{9}\ \cancel{3}\ 7 \\ -\ 5\ 3 \\ \hline 8\ 8\ 4 \end{array}$$

Step 1. Estimate the answer.**Step 2.** Arrange in columns.**Step 3.** Subtract ones. ($7 - 3 = 4$)**Step 4.** Rewrite the 93 in 937 as $80 + 13$ (“borrow 1”), shown as 8 13.**Step 5.** Subtract tens.**Step 6.** Subtract hundreds.**PROBLEM 4**Subtract $846 - 72$.

There are some problems in which we have to rewrite the numbers involved more than once. Examine the subtraction problem $732 - 453 = \underline{\hspace{2cm}}$.

Expanded Form

$$\begin{array}{r} 700 + 30 + 2 \\ (-) \quad 400 + 50 + 3 \\ \hline \end{array} \quad \text{or} \quad \begin{array}{r} 700 + 20 + 12 \\ (-) \quad 400 + 50 + 3 \\ \hline \end{array} \quad \text{or} \quad \begin{array}{r} 600 + 120 + 12 \\ (-) \quad 400 + 50 + 3 \\ \hline 200 + 70 + 9 = 279 \end{array}$$

We cannot subtract 3 from 2, so we rewrite 732 as shown on the right.

We cannot subtract 50 from 20, so we rewrite 732 again.

The short form is

$$\begin{array}{r} 12 \\ 6\ \cancel{3}\ 12 \\ -4\ 5\ 3 \\ \hline 2\ 7\ 9 \end{array}$$

EXAMPLE 5 Subtracting whole numbersSubtract $520 - 149$.**SOLUTION 5****Step 1.** Estimate the answer to the nearest hundred.**Step 2.** Arrange in columns.

$$\begin{array}{r} 520 \\ -149 \\ \hline \end{array}$$

Step 3. Rewrite 20 as $10 + 10$ (“borrow 1”) and subtract 9 from 10.

$$\begin{array}{r} 10 \\ 5\ \cancel{2}\ 0 \\ -1\ 4\ 9 \\ \hline 1 \end{array}$$

Step 4. Rewrite 51 as $40 + 11$ (“borrow 1”) and subtract 4 from 11.

$$\begin{array}{r} 4\ 11\ 10 \\ \cancel{5}\ \cancel{2}\ 0 \\ -1\ 4\ 9 \\ \hline 7\ 1 \end{array}$$

Step 5. Subtract 1 from 4.

$$\begin{array}{r} 4\ 11\ 10 \\ \cancel{5}\ \cancel{2}\ 0 \\ -1\ 4\ 9 \\ \hline 3\ 7\ 1 \end{array}$$

CHECK

$$\begin{array}{r} 11 \\ 149 \\ +371 \\ \hline 520 \end{array}$$

PROBLEM 5Subtract $680 - 295$.**Answers to PROBLEMS**

4. 774 5. 385

(continued)

The complete procedure is usually written as

$$\begin{array}{r} 4 \ 11 \ 10 \\ \cancel{8} \ \cancel{2} \ \emptyset \\ -1 \ 4 \ 9 \\ \hline 3 \ 7 \ 1 \end{array}$$

EXAMPLE 6 Subtracting whole numbers

Subtract $8340 - 2459$.

SOLUTION 6

Step 1. Estimate the answer to the nearest thousand.

Step 2. Arrange in columns.

$$\begin{array}{r} 8340 \\ -2459 \\ \hline \end{array}$$

Step 4. Rewrite 33 as $20 + 13$ (“borrow 1”) and subtract 5 from 13.

$$\begin{array}{r} 2 \ 13 \ 10 \\ 8 \ \cancel{3} \ \cancel{4} \ \emptyset \\ -2 \ 4 \ 5 \ 9 \\ \hline 8 \ 1 \end{array}$$

Step 6. Subtract 2 from 7.

$$\begin{array}{r} 12 \\ 7 \ \cancel{2} \ 13 \ 10 \\ \cancel{8} \ \cancel{3} \ \cancel{4} \ \emptyset \\ -2 \ 4 \ 5 \ 9 \\ \hline 5 \ 8 \ 8 \ 1 \end{array}$$

CHECK

$$\begin{array}{r} 111 \\ 2459 \\ +5881 \\ \hline 8340 \end{array}$$

Step 3. Rewrite 40 as $30 + 10$ (“borrow 1”) and subtract 9 from 10.

$$\begin{array}{r} 3 \ 10 \\ 8 \ 3 \ \cancel{4} \ \emptyset \\ -2 \ 4 \ 5 \ 9 \\ \hline 1 \end{array}$$

Step 5. Rewrite 82 as $70 + 12$ (“borrow 1”) and subtract 4 from 12.

$$\begin{array}{r} 12 \\ 7 \ 2 \ 13 \ 10 \\ \cancel{8} \ \cancel{3} \ \cancel{4} \ \emptyset \\ -2 \ 4 \ 5 \ 9 \\ \hline 8 \ 8 \ 1 \end{array}$$

PROBLEM 6

Subtract $5250 - 1478$.

Now let us find the difference $705 - 238 = \underline{\hspace{2cm}}$. As usual, we write

$$\begin{array}{r} 705 \\ -238 \\ \hline \end{array}$$

Since we cannot subtract 8 from 5 and obtain a whole number answer, we rewrite 705 as $690 + 15$ and then subtract as shown:

$$\begin{array}{r} 6 \ 9 \ 15 \\ \cancel{7} \ \emptyset \ \cancel{5} \\ -2 \ 3 \ 8 \\ \hline 4 \ 6 \ 7 \end{array}$$

What we have done is rewrite

$$\begin{aligned} 705 &= 70 \text{ tens} + 5 \\ &= 69 \text{ tens} + 15 \end{aligned}$$

Answers to PROBLEMS

6. 3772

EXAMPLE 7 Subtracting whole numbers

Subtract $803 - 346$.

SOLUTION 7

$$\begin{array}{r} 79\cancel{13} \\ \cancel{8}\cancel{0}\cancel{3} \\ -346 \\ \hline 457 \end{array}$$



- Step 1.** Estimate the answer.
- Step 2.** Arrange in columns.
- Step 3.** Write 803 as 79 tens + 13.
- Step 4.** Subtract ones.
- Step 5.** Subtract tens.
- Step 6.** Subtract hundreds.

PROBLEM 7

Subtract $605 - 247$.

EXAMPLE 8 Subtracting whole numbers

Subtract $7006 - 6849$.

SOLUTION 8

$$\begin{array}{r} 699\cancel{16} \\ -\cancel{7}\cancel{0}\cancel{0}\cancel{6} \\ -6849 \\ \hline 0157 \end{array}$$



- Step 1.** Estimate the answer.
- Step 2.** Arrange in columns.
- Step 3.** Rewrite 7006 as 6990 + 16.
- Step 4.** Subtract ones.
- Step 5.** Subtract tens.
- Step 6.** Subtract hundreds.
- Step 7.** Subtract thousands.

The answer is written as 157.

CHECK

$$\begin{array}{r} 111 \\ 6849 \\ + 157 \\ \hline 7006 \end{array}$$

PROBLEM 8

Subtract $6002 - 5843$.

B > Applications Involving Subtraction

Subtraction is used in everyday life. For example, if you have a checking account, the **stub** gives you a record of your balance, the amount you paid, and to whom you paid it. To find the balance carried forward, we need to subtract 38 from 213. This is done in Example 9.

1024		BALANCE BROUGHT FORWARD	213 -
DATE	August 19	DEPOSIT	
TO	City Water Co.		
FOR	Water	TOTAL	213 -
		THIS CHECK	38 -
		OTHER	
TAX DEDUCTIBLE <input type="checkbox"/>		BALANCE	

Answers to PROBLEMS

7. 358 8. 159

EXAMPLE 9 Bank stub

Find the balance carried forward on the stub shown by subtracting 38 from 213.

SOLUTION 9

New balance	213	
Amount of this check	- 38	
Balance carried forward	175	

↑ ↑ ↑

subtract ones

subtract tens

subtract hundreds

Thus, the balance carried forward is \$175.

PROBLEM 9

The new balance in an account is \$317. A check for \$59 is written. What is the balance carried forward?

EXAMPLE 10 Subtracting discount and rebate

The ad says that if you subtract the discount and rebate (\$4043) from the factory MSRP (\$19,266) you obtain the clearance price \$15,233. Use addition to check this fact.

Source: Tampa Tribune, 2/23/03, Money, 12.

FACTORY MSRP: \$19,266
DISCOUNT & REBATE: -\$4,043
Clearance Price: **\$15,233** OR **0.0%** FINANCING FOR 60 MOS. in lieu of rebates

SOLUTION 10 Remember that $a - b = c$ means that $a = c + b$, that is, $\$19,266 - \$4,043 = \$15,233$ means that $\$19,266 = \$15,233 + \$4,043$, which is not a true statement. (Add 15,233 and 4043 to check it out!) The ad was incorrect!

PROBLEM 10

Check the clearance price in the following ad:

FACTORY MSRP: \$14,880
DISCOUNT & REBATE: -\$3,882
Clearance Price: **\$10,999** OR **0.0%** FINANCING FOR 60 MOS. in lieu of rebates OR **1.9%** FINANCING FOR 72 MOS. in lieu of rebates

Suppose you have a standard vehicle but you decide to change to a hybrid vehicle, a vehicle that uses an onboard rechargeable energy storage system (RESS) and a fuel based power source for vehicle propulsion. What annual fuel savings, if any, can you expect? What about costs savings? The answer depends on many factors: the price of gas, how many miles you drive, and how many miles per gallon each car gets.

Answers to PROBLEMS

9. \$258 10. Not a true statement; should be \$10,998

GREEN MATH

EXAMPLE 11 Annual fuel savings for a hybrid car

What are the annual fuel savings of a hybrid over a standard vehicle?

Estimated Fuel Use and Savings	
Calculated Results	Values
Fuel Used Annually by Standard Vehicle (Gallons)	730
Fuel Used Annually by Hybrid Vehicle (Gallons)	519
Annual Fuel Savings of Hybrid over Standard Vehicle (Gallons)	
Estimated Costs and Savings	
Cost of Fuel Used by Standard Vehicle (\$USD)	1,750
Cost of Fuel Used by Hybrid Vehicle (\$USD)	1,247
Cost Savings of Hybrid over Standard Vehicle (\$USD)	

SOLUTION 11 We have to find the difference between 730 and 519.

Step 1. Estimate the answer ($700 - 500 = 200$).

Step 2. Arrange in columns.

$$\begin{array}{r} 210 \\ 730 \\ -519 \\ \hline 211 \end{array}$$

Step 3. Subtract ones. Rewrite the 30 in 730 as $20 + 10$, then subtract 9 from 10.

Step 4. Subtract tens. $2 - 1 = 1$

Step 5. Subtract hundreds. $7 - 5 = 2$

Thus, your annual fuel savings amount to 211 gallons, close to our 200 estimate. Don't forget to check the answer. Since $519 + 211 = 730$, we are correct! Now that you know how to do this type of problem, we will reward you. Here is a calculator that will do it for your particular car: <http://politicalcalculations.blogspot.com/2005/08/comparing-standard-and-hybrid-cars.html>.

PROBLEM 11

What are the estimated fuel costs of the hybrid over the standard vehicle?

Calculator Corner

Subtraction with a calculator is easy. As with addition, you simply press the appropriate keys. Thus, to do the problem

$$\begin{array}{r} 35 \\ -15 \\ \hline \end{array}$$

you press **3** **5** **-** **1** **5** **ENTER**. The display shows the answer, 20.

> Exercises 1.4



> Practice Problems > Self-Tests
> Media-rich eBooks > e-Professors > Videos

< **A** > **Subtracting Whole Numbers** In Problems 1–50, subtract.

1. $\begin{array}{r} 14 \\ -6 \\ \hline \end{array}$

2. $\begin{array}{r} 8 \\ -5 \\ \hline \end{array}$

3. $\begin{array}{r} 13 \\ -6 \\ \hline \end{array}$

4. $\begin{array}{r} 16 \\ -9 \\ \hline \end{array}$

5. $\begin{array}{r} 17 \\ -0 \\ \hline \end{array}$

6. $\begin{array}{r} 19 \\ -9 \\ \hline \end{array}$

7. $\begin{array}{r} 17 \\ -9 \\ \hline \end{array}$

8. $\begin{array}{r} 15 \\ -7 \\ \hline \end{array}$

9. $\begin{array}{r} 66 \\ -32 \\ \hline \end{array}$

10. $\begin{array}{r} 53 \\ -21 \\ \hline \end{array}$

11. $\begin{array}{r} 83 \\ -20 \\ \hline \end{array}$

12. $\begin{array}{r} 55 \\ -30 \\ \hline \end{array}$

Answers to PROBLEMS

11. \$503

13. $\begin{array}{r} 90 \\ -56 \\ \hline \end{array}$ 14. $\begin{array}{r} 58 \\ -40 \\ \hline \end{array}$ 15. $\begin{array}{r} 73 \\ -58 \\ \hline \end{array}$ 16. $\begin{array}{r} 96 \\ -39 \\ \hline \end{array}$ 17. $\begin{array}{r} 503 \\ -291 \\ \hline \end{array}$ 18. $\begin{array}{r} 605 \\ -332 \\ \hline \end{array}$
19. $\begin{array}{r} 578 \\ -499 \\ \hline \end{array}$ 20. $\begin{array}{r} 937 \\ -888 \\ \hline \end{array}$ 21. $725 - 318$ 22. $835 - 608$
23. $872 - 657$ 24. $742 - 345$ 25. $560 - 278$ 26. $590 - 445$
27. $905 - 726$ 28. $308 - 199$ 29. $607 - 398$ 30. $804 - 297$
31. $\begin{array}{r} 5837 \\ -3216 \\ \hline \end{array}$ 32. $\begin{array}{r} 6784 \\ -3271 \\ \hline \end{array}$ 33. $\begin{array}{r} 4783 \\ -1278 \\ \hline \end{array}$ 34. $\begin{array}{r} 6892 \\ -4583 \\ \hline \end{array}$ 35. $\begin{array}{r} 6853 \\ -2765 \\ \hline \end{array}$ 36. $\begin{array}{r} 4721 \\ -1242 \\ \hline \end{array}$
37. $\begin{array}{r} 5325 \\ -2432 \\ \hline \end{array}$ 38. $\begin{array}{r} 9423 \\ -2540 \\ \hline \end{array}$ 39. $\begin{array}{r} 3860 \\ -2971 \\ \hline \end{array}$ 40. $\begin{array}{r} 4520 \\ -3362 \\ \hline \end{array}$ 41. $\begin{array}{r} 7634 \\ -388 \\ \hline \end{array}$ 42. $\begin{array}{r} 3425 \\ -137 \\ \hline \end{array}$
43. $\begin{array}{r} 5073 \\ -782 \\ \hline \end{array}$ 44. $\begin{array}{r} 6068 \\ -697 \\ \hline \end{array}$ 45. $\begin{array}{r} 6003 \\ -289 \\ \hline \end{array}$ 46. $\begin{array}{r} 9001 \\ -539 \\ \hline \end{array}$ 47. $\begin{array}{r} 13,456 \\ -7576 \\ \hline \end{array}$ 48. $\begin{array}{r} 27,333 \\ -9666 \\ \hline \end{array}$
49. $\begin{array}{r} 50,000 \\ -23,569 \\ \hline \end{array}$ 50. $\begin{array}{r} 80,000 \\ -65,687 \\ \hline \end{array}$

< B > Applications Involving Subtraction

51. *Tallest structure in the world* The tallest structure in the world is the BurJ Khalifa, 2717 feet tall. If the Empire State Building is 1250 feet high, what is the difference between the two heights?
52. *Elevation difference* The elevation of Lhasa, Tibet, is 12,087 feet above sea level. La Paz, Bolivia, is 11,916 feet above sea level. What is the difference in altitudes?
53. *Young authors* The youngest recorded commercially published author is Dorothy Straight, born in 1958. She published her book in 1962. How old was she then?
54. *Trip length* At the beginning of a trip the odometer on a car read 37,742 miles. At the end it read 43,224. How many miles was the trip?
55. *Fall difference* Niagara Falls is 193 feet tall. Angel Falls is 2212 feet. What is the difference in heights?
56. *Passing and rushing in Miami* The professional football team that gained the most yards in a season is Miami, with 6936 yards gained in 1984. If 5018 yards were gained passing, how many did they gain rushing?
57. *Motorcycle sale* A \$3200 motorcycle is on sale for \$2999. How much can be saved by buying it at the sale price?
58. *Bank balance* Your bank balance is \$347. You write checks for \$59 and \$39. What is your new balance?
59. *Making money* A woman bought a car for \$4500. She spent \$787 on repairs and then sold it for \$6300. How much profit did she make on the car?
60. *Income after deductions* A man makes \$682 a week. The deductions are:

Withholding tax	\$87
Social Security	\$46
Union dues	\$13

What is his net income after these deductions?

61. *Real buying power* The *real buying power* of your dollar is going down fast! How can you figure it out? Here are the steps:

Jane Dough		
Adjusted gross income	\$19,205	\$20,000
Subtract federal tax	<u>- 3,574</u>	<u>- 4,672</u>
Income less federal tax	15,631	<input type="text"/>
Subtract Social Security	<u>- 1,440</u>	<u>- 1,500</u>
Net income	14,191	<input type="text"/>
Subtract 10% of net income for inflation	<u>- 1,419</u>	<u>- 1,383</u>
Real buying power	\$12,772	<input type="text"/>

62. *Real buying power* Joe Worker is single and has an adjusted gross income of \$19,000. His federal tax amounts to \$4264, his Social Security contribution is \$1273. His 10% loss due to inflation amounts to \$1346. What is his real buying power?

This means that your net income of \$14,191 will buy only \$12,772 worth of goods this year. Find the real buying power for Jane Dough using the given figures.

According to Jeff Ostroff and ConsumerNet, Inc., when you buy a new car, the *dealer's actual cost* is given by:

$$\text{Invoice Price} - \text{Factory To Dealer Incentive} - \text{Factory Holdback}$$

Source: <http://carbuyingtips.com>.

- 63.** You want to buy a Toyota Camry LE V6 with an invoice price of \$19,922. You discovered a \$500 factory to dealer incentive exists, and a 2% holdback of the MSRP (\$447).
- What is the dealer's actual cost?
 - If the dealer offers to sell you the Camry for \$22,000, how much is the dealer making?
- 64.** You want a used Toyota Corolla CE. Surf over to Edmund's; the invoice price is \$13,853. Edmund's also shows a \$900 dealer incentive and a 2% holdback of \$302.
- What is the dealer's actual cost?
 - If you are letting the dealer make \$500 on the deal, how much should you offer for the car?

These computer prices will be used in Exercises 65–70.

Cutting Edge	Performance	Affordability
Dimension 8400 from \$1019	Dimension G310 from \$689	Dimension F310 from \$968

- 65.** What is the difference in price between a Dimension 8400 and Dimension F310?
- 66.** What is the difference in price between a Dimension 8400 and Dimension G310?
- 67.** What is the difference in price between a Dimension G310 and a Dimension F310?
- 68.** If you have enough money to buy a Dimension F310, how much more money do you need to upgrade to the 8400?
- 69.** If you can afford a Dimension G310, how much more money do you need to upgrade to the 8400?
- 70.** What is the difference in price between the most expensive and the least expensive of the computers?

College makes a difference over your lifetime earnings! Check the chart!

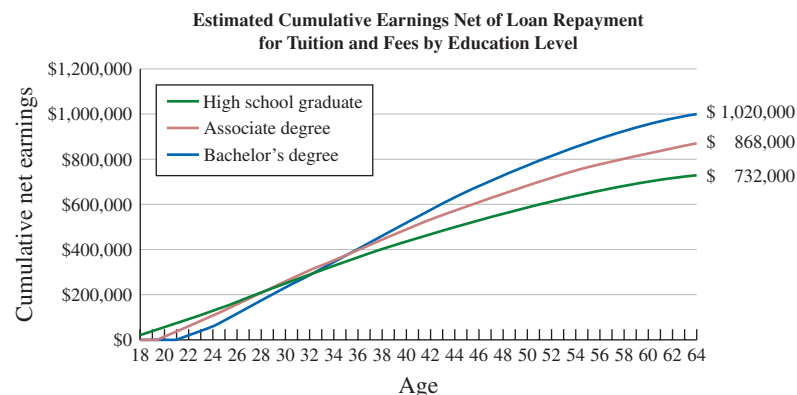

Source: College Board.

- 71.** At the beginning of your career (age 18–22) what group had the least earnings?
- 72.** At the end of your career (age 60–64), what group had the most earnings?
- 73.** At about what age did all three groups make about the same amount of money?
- 74.** What was the approximate difference in total estimated cumulative earnings between workers with a bachelor's degree and those who are high school graduates?
- 75.** What was the approximate difference in total estimated cumulative earnings between workers with a bachelor's degree and those with an associate degree?
- 76.** What was the approximate difference in total estimated cumulative earnings between workers with an associate degree and those who are high school graduates?

The table will be used in Problems 77–80.

Trends in College and University Pricing

	4-Year Public	2-Year Public	4-Year Private
Total tuition and fees	\$5491	\$2191	\$21,235

- 77. What is the price difference between a 4-year public college and a 2-year public college?
- 78. What is the price difference between a 4-year public college and a 4-year private college?

- 79. What is the price difference between a 4-year private college and a 2-year public college?
- 80. If you have saved \$3000 and want to go to a 4-year public college, how much more money do you need?
Source: Trends in College Pricing, The College Board, <http://www.ed.gov/about/bdscomm/list/hiedfuture/2nd-meeting/trends.pdf>.

Using Your Knowledge

One of the most important applications of addition and subtraction occurs in banking. To help customers keep a record of the money in their checking accounts, banks provide a **check stub** like the one shown on the right.

The first line of the stub shows that the check number (NO.) is 70. “This check” indicates that the person is paying \$120. Since the balance brought forward (the amount of money in the account) is \$380 and the amount of the check is \$120, we *subtract* \$120 from \$380, obtaining \$260, the new balance in the account. This new balance is then entered in the stub number 71, which is shown on the left below. Follow this procedure and find the new balance on each of the given stubs.

70		BALANCE BROUGHT FORWARD	380 -
DATE	January 23	DEPOSIT	
TO	Mortgage Co.		
FOR	House payment	TOTAL	380 -
		THIS CHECK	120 -
		OTHER	
TAX DEDUCTIBLE	<input type="checkbox"/>	BALANCE	260 -

81.

71		BALANCE BROUGHT FORWARD	260 -
DATE	January 23	DEPOSIT	
TO	Power Co.		
FOR	Light	TOTAL	
		THIS CHECK	50 -
		OTHER	
TAX DEDUCTIBLE	<input type="checkbox"/>	BALANCE	

82.

72		BALANCE BROUGHT FORWARD	
DATE	January 23	DEPOSIT	
TO	Gave More		
FOR	groceries	TOTAL	
		THIS CHECK	60 -
		OTHER	
TAX DEDUCTIBLE	<input type="checkbox"/>	BALANCE	

83.

73		BALANCE BROUGHT FORWARD	
DATE	January 24	DEPOSIT	
TO	Gas Co.		
FOR	gas	TOTAL	
		THIS CHECK	28 -
		OTHER	
TAX DEDUCTIBLE	<input type="checkbox"/>	BALANCE	

84.

74		BALANCE BROUGHT FORWARD	
DATE	January 25	DEPOSIT	
TO	Footsie Shoes		
FOR	shoes	TOTAL	
		THIS CHECK	23 -
		OTHER	
TAX DEDUCTIBLE	<input type="checkbox"/>	BALANCE	

Applications: Green Math

A Burning Issue The kindling (or flash) point of a substance is the amount of heat needed to make the substance burst into flames. For example, the kindling point of natural gas is 1225°F . If the kindling point of a certain piece of wood is 500°F , the difference between the kindling point of natural gas and that of wood is

$$\begin{array}{r} 1225 \\ - 500 \\ \hline 725^{\circ}\text{F} \end{array}$$

85. Find the difference ($^{\circ}\text{F}$) between the kindling point of paper and cotton (look at the graph).
86. Find the difference ($^{\circ}\text{F}$) between the kindling point of cotton and cellophane.
87. Find the difference ($^{\circ}\text{F}$) between the kindling point of cellophane and wood alcohol.
88. Find the difference ($^{\circ}\text{F}$) between the kindling point of paper and wood alcohol.
89. Find the difference ($^{\circ}\text{F}$) between the kindling point of cotton and wood alcohol.
90. Find the difference ($^{\circ}\text{F}$) between the kindling point of paper and cellophane.

Kindling Temperatures of Common Materials

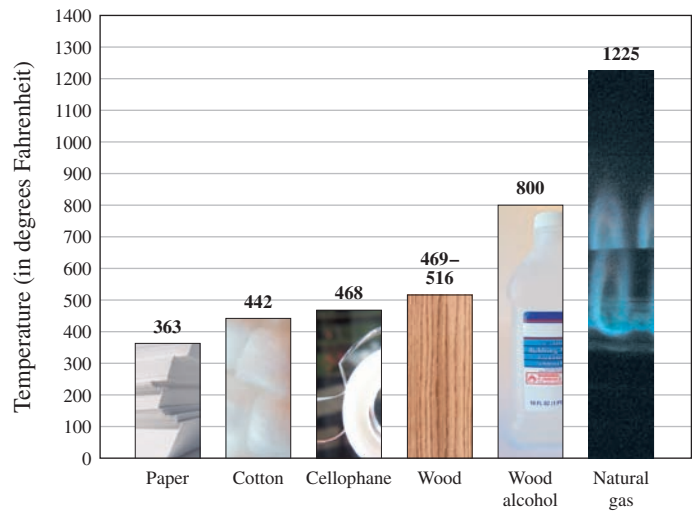

Write On

91. A subtraction problem can be changed to an addition problem; for example $20 - 15 = 5$ means that $20 = 15 + 5$. Write two more examples to demonstrate this.
92. Is the operation of subtraction commutative? Explain and give examples of why or why not.
93. Is the operation of subtraction associative? Explain and give examples of why or why not.
94. Is there an identity for subtraction? Explain.

Concept Checker

Fill in the blank(s) with the correct word(s), phrase, or mathematical statement.

95. The operation of subtraction is indicated by a _____ sign.
96. The **difference** of a and b is _____.
97. $a - b$ is a unique number c so that _____.
98. In the subtraction problem $106 - 79 = 27$, the **106** is called the _____, **79** is the _____, and **27** is the _____.
99. Addition and subtraction are _____ operations.

inverse

$a - b$

minuend

commutative

$a = c + b$

minus

associative

subtrahend

$c = b - a$

difference

$b - a$

Mastery Test

100. $632 - 216$
101. $857 - 62$
102. $720 - 169$
103. $703 - 257$
104. $8006 - 7859$
105. The balance in a checkbook is \$347. What is the new balance if you write a check for \$59?

Skill Checker

106. Add $28 + 120$.
107. Add $345 + 5400$.
108. Add $168 + 2349$.
109. Write 2348 in expanded form.
110. Write 5250 in expanded form.

1.5

Multiplication

▶ Objectives

You should be able to:

- A > Multiply two whole numbers.
- B > Multiply a whole number by any multiple of 10 (10, 100, 1000, etc.).
- C > Solve applications involving the concepts studied.
- D > Find areas using multiplication.

▶ To Succeed, Review How To . . .

Use the multiplication facts in the table on page 51.

▶ Getting Started

There's something fishy here! How many fishbowls do you see in the photo? To find the answer you can do one of the following:

1. Count the fishbowls.
2. Note that there are three bowls in each row, then add the rows like this:
 $3 + 3 + 3 + 3 = 12$
3. Multiply.

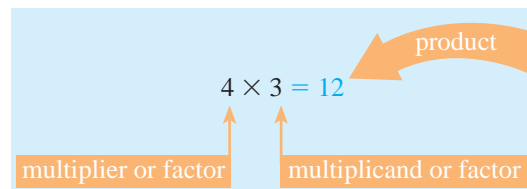

We used the product 4×3 to indicate the repeated addition $3 + 3 + 3 + 3$. We use a multiplication sign (\times) to indicate multiplication. A German mathematician by the name of Leibniz, who thought that \times could be confused with the letter x , started using the dot (\cdot) to indicate multiplication; thus 4×3 can be written as $4 \cdot 3$ or using parentheses as $(4)(3)$.



A > Multiplication of Whole Numbers

The procedure discussed is usually written as

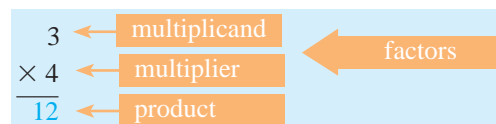

The multiplicand and the multiplier—that is, the numbers to be multiplied—are sometimes simply called **factors**. The **product** is the result of multiplication. All the multiplication facts you should know appear in the following table. As with the addition facts, you should know these facts already or take the time to memorize them now.

×	0	1	2	3	4	5	6	7	8	9
0	0	0	0	0	0	0	0	0	0	0
1	0	1	2	3	4	5	6	7	8	9
2	0	2	4	6	8	10	12	14	16	18
3	0	3	6	9	12	15	18	21	24	27
4	0	4	8	12	16	20	24	28	32	36
5	0	5	10	15	20	25	30	35	40	45
6	0	6	12	18	24	30	36	42	48	54
7	0	7	14	21	28	35	42	49	56	63
8	0	8	16	24	32	40	48	56	64	72
9	0	9	18	27	36	45	54	63	72	81

As with addition, multiplication has many useful properties. Notice in the table that when any number is multiplied by zero, the product is zero. This is called the multiplication property of zero.

MULTIPLICATION PROPERTY OF ZERO

The product of a number and zero is zero.

$$a \cdot 0 = 0$$

Also notice that when any number is multiplied by 1, the product is the same number. This is called the **Identity for Multiplication**.

IDENTITY FOR MULTIPLICATION

The product of any number and one is the number.

$$a \cdot 1 = a$$

Like addition, multiplication is both commutative and associative.

COMMUTATIVE PROPERTY OF MULTIPLICATION

Changing the *order* of two factors does not change their product.

$$a \cdot b = b \cdot a$$

Now that we know some of the multiplication properties, let us try another problem.

$$3 \times 32 = \underline{\hspace{2cm}}$$

First, we write the problem like this:

$$\begin{array}{r} 32 \\ \times 3 \\ \hline \end{array}$$

We can estimate that the answer is about $30 \times 3 = 90$. We then proceed by steps.

Step 1	Step 2	Step 3
$\begin{array}{r} 32 \\ \times 3 \\ \hline 6 \end{array}$	$\begin{array}{r} 32 \\ \times 3 \\ \hline 6 \\ \underline{90} \end{array}$	$\begin{array}{r} 32 \\ \times 3 \\ \hline 6 \\ \underline{+90} \\ 96 \end{array}$
Multiply 3 by 2.	Multiply 3 by 30.	Add 6 + 90.
$3 \times 2 = 6$	$3 \times 30 = 90$	$6 + 90 = 96$

The expanded form is

$$\begin{array}{r} 30 + 2 \\ \times 3 \\ \hline 90 + 6 = 96 \end{array}$$

The fact that we can do this multiplication is based on a property called the **Distributive Property**, which says that to multiply a number by a sum we can multiply each addend by the number and then add. Thus,

DISTRIBUTIVE PROPERTY OF MULTIPLICATION

$$a \times (b + c) = (a \times b) + (a \times c)$$

or $a \cdot (b + c) = \underline{a \cdot b} + \underline{a \cdot c}$

In our case, $3 \times (30 + 2)$

$$3 \times (30 + 2) = (3 \times 30) + (3 \times 2)$$

Note that the actual answer (96) is roughly equal to our estimate (90).

EXAMPLE 1 Multiplying whole numbers

Multiply 4×37 .

SOLUTION 1 The answer should be about $4 \times 40 = 160$. We then proceed by steps.

Step 1	Step 2	Step 3
$\begin{array}{r} 37 \\ \times 4 \\ \hline 28 \end{array}$	$\begin{array}{r} 37 \\ \times 4 \\ \hline 28 \\ \underline{120} \end{array}$	$\begin{array}{r} 37 \\ \times 4 \\ \hline 28 \\ \underline{120} \\ 148 \end{array}$
Multiply 4 by 7.	Multiply 4 by 30.	Add 28 and 120.
$4 \times 7 = 28$	$4 \times 30 = 120$	$28 + 120 = 148$

PROBLEM 1

Multiply 6×23 .

The procedure used to solve Example 1 can be shortened after some practice. Here is how.

Step 1	Step 2
$\begin{array}{r} 2 \\ 37 \\ \times 4 \\ \hline 8 \end{array}$	$\begin{array}{r} 2 \\ 37 \\ \times 4 \\ \hline 148 \end{array}$
$4 \times 7 = 28$, write 8 and carry 20.	$4 \times 30 = 120$, plus the 20 carried, is 140; write 14.

Answers to PROBLEMS

1. 138

The expanded form illustrating the procedure is

$$\begin{array}{r} 30 + 7 \\ \times 4 \\ \hline 120 + 28 = 120 + 20 + 8 \\ = 140 + 8 \\ = 148 \end{array}$$

Remember, we can indicate a multiplication by using the dot \cdot , as is done in Example 2.

EXAMPLE 2 Multiplying whole numbers

Multiply $7 \cdot 46$.

SOLUTION 2 The answer is about $7 \cdot 50 = 350$. Here are the steps.

Step 1	Step 2	Step 3
$\begin{array}{r} 46 \\ \times 7 \\ \hline 42 \end{array}$	$\begin{array}{r} 46 \\ \times 7 \\ \hline 42 \\ \underline{280} \end{array}$	$\begin{array}{r} 46 \\ \times 7 \\ \hline 42 \\ \underline{280} \\ 322 \end{array}$
Multiply 7 by 6.	Multiply 7 by 40.	Add 42 and 280.
$7 \times 6 = 42$	$7 \times 40 = 280$	$42 + 280 = 322$

PROBLEM 2

Multiply $6 \cdot 53$.

Multiplication involving two-digit factors is done in the same manner. Thus, to multiply $32 \cdot 53$, we proceed as follows:

Step 1	Step 2	Step 3
$\begin{array}{r} 53 \\ \times 32 \\ \hline 106 \end{array}$	$\begin{array}{r} 53 \\ \times 32 \\ \hline 106 \\ \underline{1590} \end{array}$	$\begin{array}{r} 53 \\ \times 32 \\ \hline 106 \\ \underline{1590} \\ 1696 \end{array}$
Multiply 2 by 53.	Multiply 30 by 53.	Add 106 and 1590.
$2 \times 53 = 106$	$30 \times 53 = 1590$ (The 0 in 1590 is usually omitted.)	$106 + 1590 = 1696$ (Note that the 0 in 1590 is omitted.)

EXAMPLE 3 Multiplying whole numbers

Multiply $43 \cdot 56$.

SOLUTION 3 The answer should be near $40 \times 60 = 2400$.

Step 1	Step 2	Step 3
$\begin{array}{r} 1 \\ 56 \\ \times 43 \\ \hline 168 \end{array}$	$\begin{array}{r} 2 \\ 56 \\ \times 43 \\ \hline 168 \\ \underline{2240} \end{array}$	$\begin{array}{r} 56 \\ \times 43 \\ \hline 168 \\ \underline{2240} \\ 2408 \end{array}$
Multiply 3 by 56.	Multiply 40 by 56.	Add 168 and 2240.
$3 \times 56 = 168$	$40 \times 56 = 2240$ (But the 0 is omitted.)	$168 + 2240 = 2408$

PROBLEM 3

Multiply $52 \cdot 38$.

Answers to PROBLEMS

2. 318 3. 1976

EXAMPLE 4 Multiplying whole numbersMultiply 132×418 .**SOLUTION 4** The answer should be about $100 \times 400 = 40,000$.

Step 1	Step 2	Step 3	Step 4
$\begin{array}{r} 1 \\ 418 \\ \times 132 \\ \hline 836 \end{array}$	$\begin{array}{r} 2 \\ 418 \\ \times 132 \\ \hline 836 \\ 1254 \end{array}$	$\begin{array}{r} 1 \\ 418 \\ \times 132 \\ \hline 836 \\ 1254 \\ \hline 418 \end{array}$	$\begin{array}{r} 418 \\ \times 132 \\ \hline 836 \\ 1254 \\ 418 \\ \hline 55176 \end{array}$
Multiply 2 by 418.	Multiply 30 by 418.	Multiply 100 by 418.	Add.
$2 \times 418 = 836$	$30 \times 418 = 12,540$	$100 \times 418 = 41,800$	$836 + 12,540 + 41,800 = 55,176$

PROBLEM 4Multiply 213×514 .**EXAMPLE 5** Multiplying whole numbersMultiply 203×417 .**SOLUTION 5** Here we should get about $200 \times 400 = 80,000$.

Step 1	Step 2	Step 3	Step 4
$\begin{array}{r} 2 \\ 417 \\ \times 203 \\ \hline 1251 \end{array}$	$\begin{array}{r} 417 \\ \times 203 \\ \hline 1251 \\ 000 \end{array}$	$\begin{array}{r} 1 \\ 417 \\ \times 203 \\ \hline 1251 \\ 000 \\ \hline 834 \end{array}$	$\begin{array}{r} 417 \\ \times 203 \\ \hline 1251 \\ 000 \\ 834 \\ \hline 84651 \end{array}$
Multiply 3 by 417.	Multiply 0 by 417.	Multiply 200 by 417.	Add.
$3 \times 417 = 1251$	$0 \times 417 = 0$	$200 \times 417 = 83,400$	$1251 + 000 + 83,400 = 84,651$

Of course, you can skip the second step and simply multiply 417 by 2, writing the 4 in 834 under the 2 in 1251 (instead of under the 5), as shown in the following short form.

$$\begin{array}{r} 417 \\ \times 203 \\ \hline 1251 \\ 8340 \\ \hline 84651 \end{array}$$

We attach a 0 to 834 to keep the columns lined up correctly.

PROBLEM 5Multiply 304×512 .**Answers to PROBLEMS**

4. 109,482 5. 155,648

EXAMPLE 6 Multiplying whole numbersMultiply 350×429 .**SOLUTION 6**

Step 1	Step 2	Step 3	Step 4
$\begin{array}{r} 429 \\ \times 350 \\ \hline 000 \end{array}$	$\begin{array}{r} 14 \\ 429 \\ \times 350 \\ \hline 000 \\ 2145 \end{array}$	$\begin{array}{r} 2 \\ 429 \\ \times 350 \\ \hline 000 \\ 2145 \\ \hline 1287 \end{array}$	$\begin{array}{r} 429 \\ \times 350 \\ \hline 000 \\ 2145 \\ \hline 1287 \\ \hline 150150 \end{array}$
Multiply 0 by 429.	Multiply 50 by 429.	Multiply 300 by 429.	Add.
$0 \times 429 = 0$	$50 \times 429 = 21,450$	$300 \times 429 = 128,700$	$000 + 21,450 + 128,700 = 150,150$

Note that you can save time by multiplying 35×429 and then attaching a zero to the result.

PROBLEM 6Multiply 290×134 .**EXAMPLE 7** Multiplying whole numbersMultiply 430×219 .

SOLUTION 7 We first multiply 43×219 , then attach zero to the result to obtain the answer.

Step 1	Step 2	Step 3
$\begin{array}{r} 2 \\ 219 \\ \times 43 \\ \hline 657 \end{array}$	$\begin{array}{r} 3 \\ 219 \\ \times 43 \\ \hline 657 \\ \hline 876 \end{array}$	$\begin{array}{r} 219 \\ \times 43 \\ \hline 657 \\ \hline 876 \\ \hline 9417 \end{array}$
Multiply 3 by 219.	Multiply 40 by 219.	Add.
$3 \times 219 = 657$	$40 \times 219 = 8760$	$657 + 8760 = 9417$

Attaching a zero to the result 9417, we have 94,170. Thus $430 \times 219 = 94,170$.

PROBLEM 7Multiply 620×318 .**B > Multiplying by Multiples of 10**

We are able to shorten the labor in Examples 6 and 7 because one of the numbers involved was a **multiple** of 10, that is, 10 multiplied by another number. Multiplication involving multiples of 10 can always be shortened. If you have been estimating the answers in Examples 1–5, the following pattern will be easy to follow.

$$\begin{array}{l} 10 \times 3 = 30 \\ 10 \times 6 = 60 \end{array} \left. \vphantom{\begin{array}{l} 10 \times 3 = 30 \\ 10 \times 6 = 60 \end{array}} \right\} \text{Add 1 zero.}$$

$$\begin{array}{l} 100 \times 3 = 300 \\ 100 \times 6 = 600 \end{array} \left. \vphantom{\begin{array}{l} 100 \times 3 = 300 \\ 100 \times 6 = 600 \end{array}} \right\} \text{Add 2 zeros.}$$

$$\begin{array}{l} 1000 \times 3 = 3000 \\ 1000 \times 6 = 6000 \end{array} \left. \vphantom{\begin{array}{l} 1000 \times 3 = 3000 \\ 1000 \times 6 = 6000 \end{array}} \right\} \text{Add 3 zeros.}$$

Answers to PROBLEMS

6. 38,860 7. 197,160

As you can see, to multiply a number by 10, 100, 1000, we simply write the number followed by as many zeros as there are in the multiplicand. Here are some more examples:

$$20 \times 3 = 10 \times 2 \times 3 = 60$$

$$30 \times 40 = 10 \times 3 \times 10 \times 4 = 1200$$

$$90 \times 70 = 10 \times 9 \times 10 \times 7 = 6300$$

$$100 \times 80 = 10 \times 10 \times 10 \times 8 = 8000$$

$$200 \times 70 = 10 \times 10 \times 2 \times 10 \times 7 = 14,000$$

The pattern here is found by multiplying the nonzero digits and adding as many zeros as appear in both factors.

EXAMPLE 8 Multiplication involving multiples of 10

- a. Multiply: 1000×7
- b. Multiply: 30×50
- c. Multiply: 300×70

SOLUTION 8

- a. $1000 \times 7 = 7000$
- b. $30 \times 50 = 1500$
- c. $300 \times 70 = 21,000$

PROBLEM 8

Multiply:

- a. 1000×5
- b. 40×90
- c. 700×80

C > Applications Involving Multiplication

Sometimes we must multiply more than two factors. For example, suppose you wish to buy a \$10,000 car. You put \$1000 down as a down payment and need to borrow the rest (say at about 6% interest) for 4 years. Under these terms your payment is \$210 per month. How much do you end up paying for the \$9000 you borrowed? The answer is

$$\begin{array}{ccc} \text{\$210} & \times & 4 \times 12 \\ \text{Monthly payment} & & \text{Number of months} \\ & & \text{in four years} \end{array}$$

We find this answer in Example 9.

EXAMPLE 9 Multiplying whole numbers

Multiply $210 \times 4 \times 12$.

SOLUTION 9 We first multiply 210 by 4, obtaining

$$\begin{array}{r} 210 \\ \times 4 \\ \hline 840 \end{array}$$

Then, multiply the product by 12.

$$\begin{array}{r} 840 \\ \times 12 \\ \hline 1680 \\ 840 \\ \hline 10080 \end{array}$$

Thus, you end up paying \$10,080 for the \$9000 you borrowed.

PROBLEM 9

Multiply $120 \times 4 \times 12$.

Carbon offsets are becoming an increasingly popular way for individuals and businesses to participate in solutions to global warming. The basic idea of a carbon offset is to figure out your personal contribution level to the global warming problem (your carbon footprint) from such activities as driving, flying, or home energy use. You can find your carbon footprint at <http://www.nature.org/initiatives/climatechange/calculator/>.

The average American produces about 17 metric tons of carbon dioxide annually.

Answers to PROBLEMS

8. a. 5000 b. 3600 c. 56,000 9. 5760

GREEN MATH

EXAMPLE 10 CO₂ emissions offsets

If it costs \$12 per metric ton to offset the amount of CO₂ you emit in a year, how much would it cost to offset 17 metric tons?

SOLUTION 10 We have to multiply 12 by 17 to find the cost.

$$\begin{array}{r} 17 \\ \times 12 \\ \hline 34 \\ 170 \\ \hline 204 \end{array}$$

Step 1. Multiply 2 by 17 ($2 \times 17 = 34$).

Step 2. $10 \times 17 = 170$

Step 3. Add 34 and 170.

The cost is \$ 204.

PROBLEM 10

The world average emissions per person are about 5 metric tons of carbon dioxide each year. At \$12 per metric ton, how much would it cost to offset 5 metric tons?

EXAMPLE 11 Strawberry fields

Here is some information about strawberries:

One pint = 15 large berries One quart = 2 pints
One flat = 8 quarts One flat = 12 pounds

- How many pints are in a flat?
- How many berries are in a flat?
- In a recent year, 6000 acres of berries were harvested. Each acre yielded about 2000 flats valued at \$10 a flat. What was the value of the total crop?

SOLUTION 11

- One flat = 8 quarts and one quart = 2 pints. So, we use substitution by exchanging 2 pints for one quart. Thus, one flat = 8 quarts = 8(2 pints) = 16 pints.

This means that one flat = 16 pints.

- Again, we use substitution by using 8 quarts for one flat, 2 pints for one quart, and 15 berries for one pint.

$$\text{One flat} = 8 \text{ quarts} = 8(2 \text{ pints}) = 8(2)(15 \text{ berries})$$

Thus, one flat = 8(2)(15) berries = 240 berries. Note that we use parentheses to indicate the multiplication: 8(2)(15) berries means $8 \times 2 \times 15$ berries.

- The value of the crop is the product of 6000 (acres), 2000 (flats), and \$10, that is,

$$6000 \times 2000 \times \$10 = \$120,000,000 \text{ ($120 million)}$$

PROBLEM 11

- How many berries are in a quart?
- What is the weight of 16 quarts?
- If 8000 acres of berries are harvested, what is the value of the crop?



In part **b** of Example 11 we can multiply 8 by 2 first and then multiply the result by 15, that is, $(8 \times 2) \times 15$. It is actually easier to multiply $8 \times (2 \times 15) = 8 \times 30 = 240$. It does not matter how we group the numbers because *multiplication is associative*.

ASSOCIATIVE PROPERTY OF MULTIPLICATION

Changing the *grouping* of two factors does not change the product.

$$\begin{aligned} a \times (b \times c) &= (a \times b) \times c \\ a \cdot (b \cdot c) &= (a \cdot b) \cdot c \end{aligned}$$

D > Finding Areas

An application of multiplication is finding the area of a region. The **area** of a region measures the amount of **surface** in the region. To find the area of a figure, we use multiplication and find the number of square units contained in the figure. Unit squares are shown on the

Answers to PROBLEMS

10. \$60 11. a. 30 berries b. 24 pounds c. \$160,000,000 or \$160 million

left below. The area of a rectangle, for example, consists of the number of square units it contains. If the rectangle measures 3 centimeters by 4 centimeters, then its area measures $3 \text{ cm} \times 4 \text{ cm} = 12 \text{ cm}^2$ (read “12 square centimeters”), as shown in the diagram.

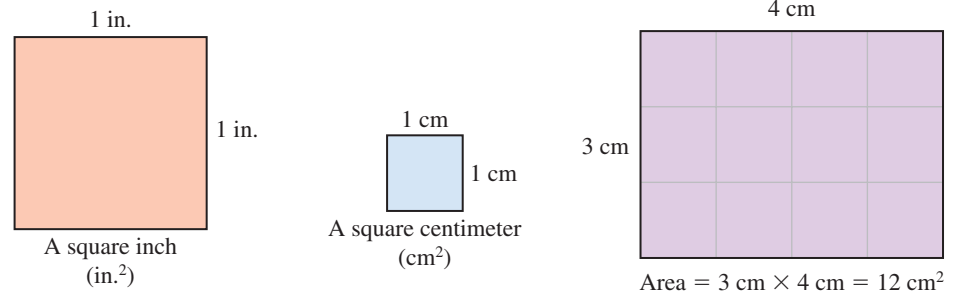

In general, we can find the area A of a rectangle by multiplying its length L by its width W , as given here.

AREA OF A RECTANGLE

The area A of a rectangle is found by multiplying its length L by its width W .

$$A = L \cdot W$$

EXAMPLE 12 Calculating area

One of the largest strawberry shortcakes ever created was made in Plant City, Florida. The table holding the shortcake measured 104 feet by 8 feet. What was the area of the table?



SOLUTION 12 The area of the table is $104 \text{ ft} \times 8 \text{ ft} = 832 \text{ ft}^2$. (Actually, the cake was 827 square feet, used 162,179 strawberries, 450 pounds of sugar, and 600 pounds of whipped cream.)

PROBLEM 12

The *St. Petersburg Times* of September 27, 2002, claims that Danny Julian made a cake measuring 40 feet by 38 feet. What is the area of this cake?

The 40-foot by 38-foot cake was assembled with two 40-foot tractor-trailer loads of 18-inch by 25-inch cakes, frozen and stacked together like bricks, with butter cream serving as mortar.



Calculator Corner

As with addition and subtraction, multiplication can be done by simply pressing the appropriate keys on the calculator. Thus, to do the problem 4×3 , we simply press **4** **×** **3** **ENTER** and the answer, 12, appears in the display. If more than two numbers are to be multiplied, the procedure is similar. Thus, to obtain the answer in Example 9, that is, to find $210 \times 4 \times 12$, we proceed as follows: **2** **1** **0** **×** **4** **×** **1** **2** **ENTER**, obtaining the answer, 10080, in the display. Note that **you** must insert the comma in this answer to obtain the final result, 10,080.

Answers to PROBLEMS

12. 1520 ft²

> Exercises 1.5



> Practice Problems > Self-Tests
> Media-rich eBooks > e-Professors > Videos

< A > Multiplication of Whole Numbers In Problems 1–34, multiply.

1. a. $\begin{array}{r} 3 \\ \times 4 \\ \hline \end{array}$

2. a. $\begin{array}{r} 5 \\ \times 2 \\ \hline \end{array}$

3. a. $\begin{array}{r} 9 \\ \times 1 \\ \hline \end{array}$

4. a. $\begin{array}{r} 0 \\ \times 6 \\ \hline \end{array}$

5. a. $\begin{array}{r} 5 \\ \times 8 \\ \hline \end{array}$

b. $\begin{array}{r} 3 \\ \times 7 \\ \hline \end{array}$

b. $\begin{array}{r} 5 \\ \times 9 \\ \hline \end{array}$

b. $\begin{array}{r} 8 \\ \times 1 \\ \hline \end{array}$

b. $\begin{array}{r} 0 \\ \times 9 \\ \hline \end{array}$

b. $\begin{array}{r} 9 \\ \times 8 \\ \hline \end{array}$

6. a. $\begin{array}{r} 9 \\ \times 6 \\ \hline \end{array}$

7. a. $\begin{array}{r} 0 \\ \times 0 \\ \hline \end{array}$

8. a. $\begin{array}{r} 7 \\ \times 0 \\ \hline \end{array}$

9. a. $\begin{array}{r} 1 \\ \times 8 \\ \hline \end{array}$

10. a. $\begin{array}{r} 1 \\ \times 0 \\ \hline \end{array}$

b. $\begin{array}{r} 7 \\ \times 6 \\ \hline \end{array}$

b. $\begin{array}{r} 0 \\ \times 3 \\ \hline \end{array}$

b. $\begin{array}{r} 4 \\ \times 0 \\ \hline \end{array}$

b. $\begin{array}{r} 1 \\ \times 4 \\ \hline \end{array}$

b. $\begin{array}{r} 8 \\ \times 1 \\ \hline \end{array}$

11. $6 \cdot 8$

12. $0 \cdot 9$

13. $1 \cdot 5$

14. $6 \cdot 1$

15. $9 \cdot 9$

16. $1 \cdot 1$

17. $0 \cdot 1$

18. $9 \cdot 8$

19. $4 \cdot 4$

20. $8 \cdot 8$

21. $\begin{array}{r} 10 \\ \times 9 \\ \hline \end{array}$

22. $\begin{array}{r} 10 \\ \times 5 \\ \hline \end{array}$

23. $\begin{array}{r} 20 \\ \times 8 \\ \hline \end{array}$

24. $\begin{array}{r} 90 \\ \times 5 \\ \hline \end{array}$

25. $\begin{array}{r} 53 \\ \times 6 \\ \hline \end{array}$

26. $\begin{array}{r} 39 \\ \times 4 \\ \hline \end{array}$

27. $\begin{array}{r} 48 \\ \times 17 \\ \hline \end{array}$

28. $\begin{array}{r} 98 \\ \times 15 \\ \hline \end{array}$

29. $\begin{array}{r} 608 \\ \times 32 \\ \hline \end{array}$

30. $\begin{array}{r} 508 \\ \times 23 \\ \hline \end{array}$

31. $\begin{array}{r} 1234 \\ \times 3 \\ \hline \end{array}$

32. $\begin{array}{r} 4321 \\ \times 4 \\ \hline \end{array}$

33. $\begin{array}{r} 35,209 \\ \times 16 \\ \hline \end{array}$

34. $\begin{array}{r} 43,802 \\ \times 15 \\ \hline \end{array}$

< B > Multiplying by Multiples of 10 In Problems 35–50, multiply.

35. $\begin{array}{r} 63 \\ \times 40 \\ \hline \end{array}$

36. $\begin{array}{r} 83 \\ \times 30 \\ \hline \end{array}$

37. $\begin{array}{r} 249 \\ \times 50 \\ \hline \end{array}$

38. $\begin{array}{r} 296 \\ \times 60 \\ \hline \end{array}$

39. $\begin{array}{r} 346 \\ \times 420 \\ \hline \end{array}$

40. $\begin{array}{r} 671 \\ \times 350 \\ \hline \end{array}$

41. $\begin{array}{r} 2260 \\ \times 200 \\ \hline \end{array}$

42. $\begin{array}{r} 3160 \\ \times 300 \\ \hline \end{array}$

43. $\begin{array}{r} 3020 \\ \times 405 \\ \hline \end{array}$

44. $\begin{array}{r} 6050 \\ \times 802 \\ \hline \end{array}$

45. $20 \cdot 5$

46. $(30)(90)$

47. $(700)(80)$

48. $120 \cdot 30$

49. $300 \cdot 200$

50. 600×900

< C > Applications Involving Multiplication

51. *Ostrich strides* An ostrich covers 25 feet in one stride. How far does it go in 8 strides?

52. *Patterns* Copy the pattern and write the missing numbers. Verify your answer by multiplying.

a. $1 \times 1 = 1$

$2 \times 2 = 1 + 2 + 1$

$3 \times 3 = 1 + 2 + 3 + 2 + 1$

$4 \times 4 = 1 + 2 + 3 + 4 + 3 + 2 + 1$

$= 1 + 2 + 3 + 4 + 5 + 4 + 3 + 2 + 1$

b. $999,999 \times 2 = 1,999,998$

$999,999 \times 3 = 2,999,997$

$999,999 \times 4 =$

c. $1 \times 9 + 2 = 11$

$12 \times 9 + 3 = 111$

$123 \times 9 + 4 = 1111$

$1234 \times 9 + 5 =$

- 53. Distance traveled by light** Light travels 300,000 kilometers per second. How far would light travel in
- 20 seconds?
 - 25 seconds?
 - 30 seconds?
- 55. Borrowing and interest** You borrow \$8000 (at 11% interest) for a period of 4 years. Your monthly payments amount to \$206. How much will you end up paying for the \$8000 borrowed? (See Example 9 in this section.)
- 57. Weeks** There are 52 weeks in a year. How many weeks are there in
- 5 years?
 - 10 years?
- 59. Oil consumption** In 2010, the estimated annual oil consumption of the United States is 8 billion barrels. At this rate, how much oil will be used in the next 8 years?
- 54. Hours in day, week, month** How many hours are there in
- 3 days?
 - A week?
 - A 30-day month?
 - A year (365 days)?
- 56. How far can you go?** A car can go about 28 miles on one gallon of gas. How far could it go on
- 2 gallons?
 - 5 gallons?
 - 10 gallons?
- 58. Earth weight** An object weighs six times as much on Earth as on the moon. Find the Earth weights of these:
- An astronaut weighing 27 pounds on the moon.
 - The Lunar Rover used by the astronauts of *Apollo 15*, which weighs 75 pounds on the moon.
 - The rocks brought back by the *Apollo 16* crew, which weighed 35 pounds on the moon.
- 60. Caloric intake** The caloric intake needed to maintain your weight is found by multiplying your weight by 15. For example, a 200-pound man needs

$$15 \times 200 = 3000 \text{ calories a day}$$

Find the caloric intake for:

< D > Finding Areas

- 61. Lots of eggs!** One of the largest omelets ever cooked was 30 feet long by 10 feet wide. What was its area?
- 63. Area of baseball diamond** Find the area of the region enclosed by the base lines on the baseball diamond shown.
- 62. Swimming, anyone?** One of the largest rectangular pools in the world is in Casablanca, Morocco, and it is 480 meters long and 75 meters wide. What is the area covered by the pool?
- 64. Area of basketball court** Find the area of the basketball court shown.

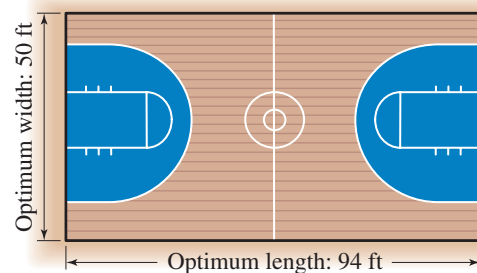
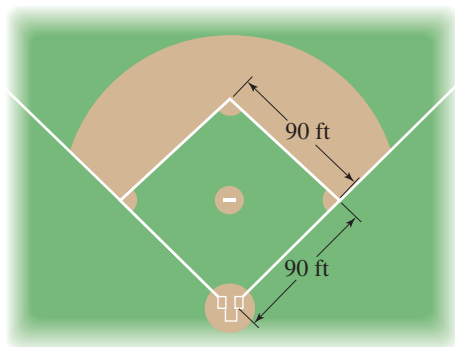

- 65. Area of football field** Find the area of the football field.

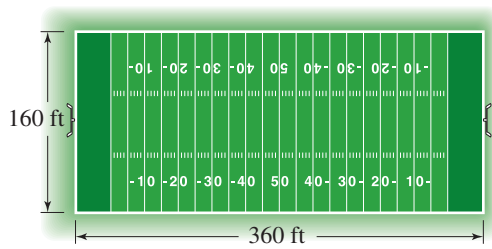

- 67. Trees** The average American uses the equivalent of seven trees a year in paper, wood, and other products. If there are about 300 million Americans, how many trees are used in a year?

Source: <http://members.aol.com>.

- 69. Water flow** Assuming a 5 gallon per minute flow, how much water could Tran save in a year (365 days) by taking a daily 4-minute shower instead of a daily 5-minute shower?

Source: <http://www.asheonline.com>.

- 71. Don't dump it!** A gallon of paint or a quart of motor oil can seep into the earth and pollute 250,000 gallons of drinking water. When changing the oil in your car, 5 quarts of motor oil are accidentally spilled and seep into the earth. How many gallons of drinking water can be polluted by the spill?

Source: <http://www.leeric.lsu.edu>.

- 66. Area** What is the area of the hockey rink?

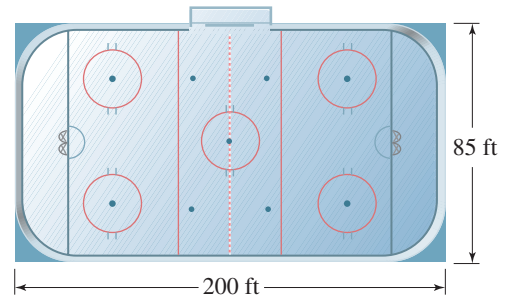

- 68. Water flow** A standard shower head has a flow rate of 5 to 10 gallons of water per minute. Most people take 5-minute showers. Assuming a 5 gallons per minute flow rate, how many gallons of water are used for a 5-minute shower? How many gallons of water does a family of four use in a week (7 days) assuming they each take a daily 5-minute shower?

Source: <http://www.asheonline.com>.

- 70. Gallons and gallons** A bath uses 50 gallons of water. Assuming a 5 gallon per minute flow, how much water could a person save in a week (7 days) by taking a daily 5-minute shower instead of a bath?

Source: <http://www.asheonline.com>.

- 72. Watch that tank!** A spilled gallon of gasoline can pollute 750,000 gallons of water. How many gallons of water can be polluted if your 13 gallon tank of gas leaks into the ground?

Source: <http://www.leeric.lsu.edu>.

Applications: Green Math

- 73. CO₂ emissions from an Escalade** An Escalade has a 26-gallon gas tank. How many pounds of carbon dioxide (CO₂) gas are produced for each tank of gas if each gallon produces about 19 pounds of CO₂?

- 75. Annual gas consumption for an Escalade** An Escalade gets about 13 miles per gallon of gas, and you need about 1150 gallons of gas a year. At \$4 per gallon, how much is that? If each gallon of gas produces about 19 pounds of CO₂, how many pounds of CO₂ will you produce driving the Escalade?

- 74. Annual cost of gas** An Escalade gets about 13 miles per gallon of gasoline. If you pay \$4 per gallon and you drive 13,000 miles per year, how much is the annual cost of the gas?

- 76. Cost of gas and emissions for a Honda** A 6-cylinder Honda Accord gets about 25 miles per gallon of gas, so you only need about 600 gallons of gas to drive 15,000 miles per year. At \$4 per gallon, how much is that? If each gallon of gas produces about 19 pounds of CO₂, how many pounds of CO₂ will you produce driving the Honda? Compare with the Escalade of Problem 75.

Using Your Knowledge

A Weighty Matter How much should you weigh? There is a formula to estimate your ideal weight. For an average man the formula is like this:

$$\text{Ideal weight} = \text{height (inches)} \times 4 - 130$$

For women,

$$\text{Ideal weight} = \text{height (inches)} \times 4 - 140$$

For example, the ideal weight for a 70-inch woman is calculated as follows:

$$\begin{aligned} \text{Ideal weight} &= 70 \times 4 - 140 \\ &= 280 - 140 \\ &= 140 \end{aligned}$$

77. Use the formula to find the ideal weight of a man 6 feet tall (72 inches).

The amount of food (calories) needed to maintain your ideal weight depends on your activities. Rate yourself on the following scale.

- 13 Very inactive
14 Slightly inactive
15 Moderately active
16 Relatively active
17 Frequently active

78. Use the formula to find the ideal weight of a woman 5 feet 8 inches tall (68 inches).

To find the daily calories needed to maintain your ideal weight, use the following formula:

$$\text{Calories needed} = \text{ideal weight} \times \text{activity level (from table)}$$

For example, a 200-pound office worker who is 13 on the scale calculated his need like this:

$$\text{Calories needed} = 200 \times 13 = 2600$$

79. Find the calories needed by a 150-pound man who is:
a. Moderately active. b. Frequently active.

>>> Write On

80. Write in your own words the procedure you use to multiply a whole number by 10, 100, or 1000.
81. Write in your own words the meaning of the commutative property of multiplication. How does this property compare to the commutative property of addition?
82. Write in your own words what it means when we say that 1 is the identity for multiplication. Why do you think they use the word identity to describe the number 1? What is the identity for addition?
83. Write in your own words the meaning of the associative property of multiplication. How does this property compare to the associative property of addition?
84. Which of the properties mentioned (commutative, associative, identity), if any, apply to the operation of subtraction? Explain and give examples.

>>> Concept Checker

Fill in the blank(s) with the correct word(s), phrase, or mathematical statement.

85. The **product** of a and b can be written three ways: _____, _____, and _____.
86. When we write $5 \times 4 = 20$, the 5 is the _____, the 4 is the _____, and the 20 is the _____.
87. The **multiplicand** and the **multiplier** are also called _____.
88. The **Commutative Property** of multiplication states that _____.
89. The **identity** for multiplication is _____.
90. $a \cdot (b + c) =$ _____.
91. The **Associative Property** of multiplication states that $(a \cdot b) \cdot c =$ _____.
92. The **area** of a rectangle of length L and width W is _____.

multiplicand	1
$L \cdot W$	$a \cdot (b \cdot c)$
$(a \cdot b) \cdot c$	$a \times b$
multiplier	$a \cdot b$
0	$(a)(b)$
product	$a \cdot b + a \cdot c$
factors	
$a \times b = b \times a$	

>>> Mastery Test

93. Multiply $210 \times 5 \times 12$.
94. Multiply 4000×80 .
95. Multiply 450×319 .
96. Multiply 403×319 .
97. Multiply 129×318 .
98. Multiply 53×65 .
99. Multiply 7×56 .
100. Multiply 1000×9 .
101. One pint contains about 15 large berries, and one quart is equivalent to two pints. How many berries are in a quart?
102. A volleyball playing court is 30 feet by 60 feet. What is the area of the court?

>>> Skill Checker

103. Write 234 in expanded notation.
104. Write 758 in expanded notation
105. Add 349 and 786.
106. Add 1289 and 7893.
107. Subtract 728 from 3500.
108. Subtract 999 from 2300.

1.6

Division

▶ Objectives

You should be able to:

- A > Write a division problem as an equivalent multiplication problem.
- B > Divide a counting number by another using long division.
- C > Solve applications using the concepts studied.

▶ To Succeed, Review How To . . .

1. Use the definition of a counting number. (p. 3)
2. Use the multiplication facts. (p. 51)

▶ Getting Started



Suppose you have 12 cents to spend on 3-cent stamps. How many stamps can you buy? If you have 12 pennies, you can separate them into equal groups of 3. Since there are four groups, you can buy four 3-cent stamps with 12 cents, as shown in the photo. We have separated a quantity into 4 equal groups. This process is called **division**. Of course, the problem could have been solved by dividing the money available (12 cents) by the cost of each stamp (3 cents).

A > Writing Division as Multiplication

In mathematics the phrase “twelve divided by 3” is written like this:

$$12 \div 3 = 4$$

where \div is the sign used to indicate division. In this problem, 12, the number being divided, is the **dividend**; 3, the number used to divide, is the **divisor**; and 4, the result of the division, is called the **quotient**. The mathematical statement $12 \div 3 = 4$ (twelve divided by three equals four) can also be written as

$$\frac{12}{3} = 4 \quad 12/3 = 4 \quad 3\overline{)12} \quad 4$$

Here is the definition.

DIVISION

The quotient $a \div b$, where $b \neq 0$, is the unique whole number c so that $a = b \times c$

How can you check the fact that $12/3 = 4$? One way is to use multiplication. By definition,

$$12 \div 3 = \square \text{ means that } 12 = 3 \times \square$$

This makes multiplication the inverse process of division. By placing 4 in the \square you make the statement $12 = 3 \times \square$ true. Similarly, to find $42 \div 6 = \square$ you think “ $42 = 6 \times \square$.” Since $42 = 6 \times 7$, $42 \div 6 = 7$.

EXAMPLE 1 Rewriting division as multiplication

Write each division problem as an equivalent multiplication problem, then find the answer.

a. $36 \div 9 = \square$ b. $54 \div 6 = \square$

SOLUTION 1

a. $36 \div 9 = \square$ can be written as $36 = 9 \times \square$. Since $36 = 9 \times 4$, $36 \div 9 = 4$.

b. $54 \div 6 = \square$ can be written as $54 = 6 \times \square$. Since $54 = 6 \times 9$, $54 \div 6 = 9$.

PROBLEM 1

Write each division problem as an equivalent multiplication problem, then find the answer.

a. $63 \div 9 = \square$

b. $56 \div 8 = \square$

As with addition and multiplication, the operation of division has some important properties.

DIVISION PROPERTIES OF 1

1. For any nonzero number a , $a \div a = 1$. A nonzero number divided by itself is 1.
2. For any number a , $a \div 1 = a$. Any number divided by 1 is the number.

DIVISION PROPERTIES OF 0

1. For any nonzero number a , $0 \div a = 0$. Zero divided by any nonzero number is 0.
2. For any number a , $a \div 0$ is undefined. Division by zero is undefined.

EXAMPLE 2 Rewriting division as multiplication

Write each division problem as an equivalent multiplication problem, then find the answer if possible.

a. $8 \div 8 = \square$ b. $8 \div 1 = \square$

c. $0 \div 8 = \square$ d. $8 \div 0 = \square$

SOLUTION 2

a. $8 \div 8 = \square$ can be written as $8 = 8 \times \square$. Since $8 \times 1 = 8$, $8 \div 8 = 1$.

b. $8 \div 1 = \square$ can be written as $8 = 1 \times \square$. Since $1 \times 8 = 8$, $8 \div 1 = 8$.

c. $0 \div 8 = \square$ can be written as $0 = 8 \times \square$. Since $8 \times 0 = 0$, $0 \div 8 = 0$.

d. $8 \div 0 = \square$ can be written as $8 = 0 \times \square$. Since there is *no* number such that $8 = 0 \times \square$, $8 \div 0$ is not defined.

PROBLEM 2

Write each division problem as an equivalent multiplication problem, then find the answer if possible.

a. $9 \div 9 = \square$

b. $9 \div 1 = \square$

c. $0 \div 9 = \square$

d. $9 \div 0 = \square$

Answers to PROBLEMS

1. a. $63 = 9 \times \square$; 7 b. $56 = 8 \times \square$; 7

2. a. $9 = 9 \times \square$; 1 b. $9 = 1 \times \square$; 9 c. $0 = 9 \times \square$; 0 d. $9 \div 0 = \square$; means $9 = 0 \times \square$, which is undefined. You cannot divide by 0.

How do we divide 67 by 13? Since we wish to find out how many groups of 13 there are in 67, we can do it by repeated subtractions, like this.

$$\begin{array}{r}
 67 \\
 -13 \rightarrow \text{First subtraction} \\
 \hline
 54 \\
 -13 \rightarrow \text{Second subtraction} \\
 \hline
 41 \\
 -13 \rightarrow \text{Third subtraction} \\
 \hline
 28 \\
 -13 \rightarrow \text{Fourth subtraction} \\
 \hline
 15 \\
 -13 \rightarrow \text{Fifth subtraction} \\
 \hline
 2 \\
 \text{Remainder} \rightarrow
 \end{array}$$

Thus, there are 5 thirteens in 67, with a **remainder** of 2. The remainder is what is left over. We then write

$$\begin{array}{ccccccc}
 & & 67 & \div & 13 & = & 5 & \text{r} & 2 \\
 & \nearrow & & & \nearrow & & \nearrow & & \nearrow \\
 & \text{Dividend} & & & \text{Divisor} & & \text{Quotient} & & \text{Remainder}
 \end{array}$$

As before, we can check this by multiplying $5 \times 13 = 65$ and then adding the remainder, 2, to the 65, obtaining the required 67.

But you don't have to do division using this method! Here is a better procedure!

B > Long Division

When doing long division, we still use repeated subtractions, but we write the procedure in a different way. We use the symbol $\overline{)}$ to indicate division, placing the **divisor** to the left of the division sign $\overline{)}$ and the **dividend** inside. Here is the set up:

$$\begin{array}{r}
 \text{quotient} \\
 \text{divisor} \overline{) \text{dividend}}
 \end{array}$$

Next, we want to find the *first digit* in the quotient. Here is the way to do it:

1. If the first digit in the dividend is greater than or equal to the divisor, divide it by the divisor and write the quotient of that division directly above the *first digit* of the dividend. If this is not the case, then go to step 2.
2. Divide the first *two digits* of the dividend by the divisor and write the quotient of that division directly above the *second digit* of the dividend.

We illustrate this procedure in Example 3, where we are dividing 786 by 6.

EXAMPLE 3 Using long division

Divide $786 \div 6$.

SOLUTION 3

$$\begin{array}{r}
 6 \overline{) 786} \\
 \underline{6} \\
 18 \\
 \underline{18} \\
 06 \\
 \underline{06} \\
 0
 \end{array}$$

Step 1. Arrange the divisor and dividend horizontally, as shown.
Step 2. 6 goes into 7 once. Write 1 above the 7.
Step 3. $6 \times 1 = 6$; subtract $7 - 6 = 1$.
Step 4. Bring down the 8. Now, 6 goes into 18 three times. Write 3 above the 8.
Step 5. $6 \times 3 = 18$; subtract $18 - 18 = 0$.
Step 6. Bring down the 6. The 6 goes into 6 once. Write 1 above the 6.
Step 7. $6 \times 1 = 6$; subtract $6 - 6 = 0$.

Thus, $786 \div 6 = 131$.

PROBLEM 3

Divide $917 \div 7$.

In Examples 1, 2, and 3, the remainders have been zero. This means that the dividend is exactly divisible by the divisor. Of course, not all problems are like this. Here is one in which a nonzero remainder occurs. In such cases, we continue the long division process until the *remainder is less than the divisor*.

EXAMPLE 4 Using long divisionDivide $1729 \div 9$.**SOLUTION 4**

$$\begin{array}{r} 9 \overline{)1729} \\ 192 \\ \hline 9 \overline{)1729} \\ -9 \\ \hline 82 \\ -81 \\ \hline 19 \\ -18 \\ \hline 1 \end{array}$$

Step 1. Arrange the divisor and dividend horizontally, as shown.**Step 2.** You cannot divide 1 by 9, so divide 17 by 9. 9 goes into 17 once. Write 1 above the 7.**Step 3.** $9 \times 1 = 9$; subtract $17 - 9 = 8$.**Step 4.** Bring down the 2. Now, 9 goes into 82 nine times. Write 9 above the 2.**Step 5.** $9 \times 9 = 81$; subtract $82 - 81 = 1$.**Step 6.** Bring down the 9. The 9 goes into 19 twice. Write 2 above the 9.**Step 7.** $9 \times 2 = 18$; subtract $19 - 18 = 1$.

The remainder 1 is less than the divisor 9, so we can stop. The answer is 192 with a remainder of 1 and we write $1729 \div 9 = 192 \text{ r } 1$. This is true because $1729 = 9 \times 192 + 1$, as shown in the diagram:

Start here →

$$9 \times 192 + 1 = 1729$$

$$= \begin{array}{r} \times \\ 192 \\ 9 \overline{)1729} \\ -9 \\ \hline 82 \\ -81 \\ \hline 19 \\ -18 \\ \hline 1 \end{array} +$$

Here is a slightly different example.

EXAMPLE 5 Using long divisionDivide $809 \div 8$.**SOLUTION 5**

$$\begin{array}{r} 8 \overline{)809} \\ 101 \\ \hline 8 \overline{)809} \\ -8 \\ \hline 009 \\ -8 \\ \hline 1 \end{array}$$

Step 1. Arrange the divisor and dividend horizontally, as shown.**Step 2.** 8 goes into 8 once. Write 1 above the 8.**Step 3.** $8 \times 1 = 8$; subtract $8 - 8 = 0$.**Step 4.** Bring down the 0 in 809. The 0 divided by 8 is 0. Write 0 above the 0 in 809.**Step 5.** Bring down the 9. Now, 8 goes into 9 once. Write 1 above the 9 in 809.**Step 6.** $8 \times 1 = 8$; subtract $9 - 8 = 1$.**PROBLEM 4**Divide $1367 \div 4$.**PROBLEM 5**Divide $709 \div 7$.**Answers to PROBLEMS**4. $341 \text{ r } 3$ 5. $101 \text{ r } 2$

The remainder 1 is less than the divisor 8, so we can stop. The answer is 101 with a remainder of 1 and we write $809 \div 8 = 101 \text{ r } 1$. This can be checked by following the diagram:

That is, $8 \times 101 + 1 = 809$.

We now give an example involving division by a two-digit number.

EXAMPLE 6 Using long division

Find the quotient and the remainder: $1035 \div 43$.

SOLUTION 6

$$\begin{array}{r} 24 \\ 43 \overline{)1035} \\ \underline{-86} \\ 175 \\ \underline{-172} \\ 3 \end{array}$$

Step 1. Arrange the divisor and dividend horizontally, as shown.

Step 2. 43 does not go into 10. Try to divide 103 by 43. 103 divided by 43 should be about 2 since 100 divided by 50 is 2. Since $43 \times 2 = 86$, it goes twice. Write 2 above the 3.

Step 3. $43 \times 2 = 86$; subtract $103 - 86 = 17$.

Step 4. Bring down the 5. The 43 goes into 175 four times. Write 4 above the 5.

Step 5. $43 \times 4 = 172$; subtract $175 - 172 = 3$.

The quotient is 24 with a remainder of 3. Now, 3 is less than the divisor 43, so we can stop and write $1035 \div 43 = 24 \text{ r } 3$. Since $43 \times 24 + 3$ is 1035, our result is correct.

PROBLEM 6

Find the quotient and the remainder:
 $1029 \div 45$.

C > Applications Involving Division

A person's annual salary is usually paid monthly, biweekly, or weekly. In any case, to find the amount of money the person is to receive each pay period, we must use **division**. For a \$19,500 annual salary, the amount received each *monthly* pay period should be

$$\frac{19,500}{12} \quad \begin{array}{l} \leftarrow \text{Annual salary} \\ \leftarrow \text{Months in a year} \end{array}$$

In Example 7 we find out how much this is.

EXAMPLE 7 Using long division

Divide 19,500 by 12.

SOLUTION 7

$$\begin{array}{r} 1625 \\ 12 \overline{)19500} \\ \underline{12} \\ 75 \\ \underline{72} \\ 30 \\ \underline{24} \\ 60 \\ \underline{60} \\ 0 \end{array}$$

Step 1. Arrange the divisor and dividend horizontally, as shown.

Step 2. 12 goes into 19 once. Write 1 above the 9.

Step 3. $12 \times 1 = 12$; subtract $19 - 12 = 7$.

Step 4. Bring down the 5. The 12 goes into 75 six times. Write 6 above the 5.

Step 5. $12 \times 6 = 72$; subtract $75 - 72 = 3$.

Step 6. Bring down the 0. Now, 12 goes into 30 twice. Write 2 above the first 0.

Step 7. $12 \times 2 = 24$; subtract $30 - 24 = 6$.

PROBLEM 7

If a person earns \$19,500 annually, the biweekly salary will be

$$\frac{\$19,500}{26}$$

Divide \$19,500 by 26.

Answers to PROBLEMS

6. 22 r 39 7. \$750

(continued)

Step 8. Bring down the other 0. The 12 goes into 60 five times. Write 5 above the second 0.

Step 9. $12 \times 5 = 60$; subtract $60 - 60 = 0$.

The answer is 1625 with no remainder. Thus, if a person earns \$19,500 annually, the monthly salary will be \$1625.

GREEN MATH

EXAMPLE 8 Checking water leaks to save water

According to Green Globe if water leaks from a tap or faucet at just one drop per second, you would be wasting 10,220 liters of water per year. If we assume a year has 365 days, how many liters per day is that?

SOLUTION 8 To find the answer, we have to divide 10,220 (the number of liters used) by 365 (the number of days in a year)

$$\begin{array}{r} 28 \\ 365 \overline{)10220} \\ \underline{-730} \\ 2920 \\ \underline{-2920} \\ 0 \end{array}$$

Step 1. Arrange the divisor and dividend, as shown.

Step 2. 365 goes into 1022 twice. Write 2 above the 2 in 10,220.

Step 3. $2 \times 365 = 730$; subtract 730 from 1022.

Step 4. Bring down the 0. 365 goes into 2920 eight times (you may have to try a couple of numbers, like 7, which is too small, or 9, which is too big). Write 8 above the 0.

Step 5. $8 \times 365 = 2920$

Step 6. Subtract 2920 from 2920, which is 0.

Thus, the answer is 28 with no remainder, which means that you will be wasting 28 liters of water every day!

Source: <http://greenglobeideas.com/idea/saving-water-indoors>.

PROBLEM 8

Do you take a bath or a shower? Replacing one bath a week with a shower will save a family of four 300 gallons of water per year. How many gallons per person is that?



Calculator Corner

Division is faster with a calculator, especially if there is *no* remainder. Thus, to divide 12 by 3, we press **1** **2** **÷** **3** **ENTER** and the result, 4, appears in the display. If there is a remainder, the calculator gives that remainder in the form of a **decimal**.

> Exercises 1.6



> Practice Problems > Self-Tests
> Media-rich eBooks > e-Professors > Videos

< **A** > **Writing Division as Multiplication** In Problems 1–20, divide and check using multiplication.

1. $30 \div 5$

2. $63 \div 9$

3. $28 \div 4$

4. $6 \div 1$

5. $21 \div 7$

6. $2 \div 0$

7. $0 \div 2$

8. $54 \div 9$

9. $7 \div 7$

10. $56 \div 8$

11. $\frac{36}{9}$

12. $54 \div 6$

13. $\frac{3}{0}$

14. $\frac{0}{3}$

15. $\frac{32}{8}$

16. $\frac{13}{13}$

17. $\frac{24}{1}$

18. $\frac{45}{9}$

19. $\frac{62}{6}$

20. $\frac{48}{5}$

Answers to PROBLEMS

8. 75

< B > Long Division In Problems 21–50, use long division to divide.

- | | | | |
|------------------------------|------------------------------|----------------------------|------------------------------|
| 21. $6\overline{)366}$ | 22. $7\overline{)371}$ | 23. $8\overline{)5048}$ | 24. $7\overline{)6097}$ |
| 25. $4\overline{)2055}$ | 26. $9\overline{)6013}$ | 27. $336 \div 14$ | 28. $340 \div 17$ |
| 29. $399 \div 19$ | 30. $406 \div 13$ | 31. $605 \div 10$ | 32. $600 \div 27$ |
| 33. $\frac{704}{16}$ | 34. $\frac{903}{17}$ | 35. $\frac{805}{81}$ | 36. $11\overline{)341}$ |
| 37. $12\overline{)505}$ | 38. $46\overline{)508}$ | 39. $22\overline{)1305}$ | 40. $53\overline{)1325}$ |
| 41. $42\overline{)9013}$ | 42. $111\overline{)3414}$ | 43. $123\overline{)5583}$ | 44. $253\overline{)8096}$ |
| 45. $417\overline{)36,279}$ | 46. $505\overline{)31,815}$ | 47. $50\overline{)31,500}$ | 48. $600\overline{)188,400}$ |
| 49. $654\overline{)611,302}$ | 50. $703\overline{)668,553}$ | | |

< C > Applications Involving Division

51. *Shares sold* A stockbroker sold \$12,600 worth of stocks costing \$25 per share. How many shares were sold?
52. *Tickets purchased* Receipts at a football game were \$52,640. If tickets sold for \$7, how many tickets were purchased for the game?
53. *Loads in the dishwasher* A dishwasher uses 14 gallons of hot water per load. If 42 gallons were used, how many loads were washed?
54. *Figuring miles per gallon* A car is driven 348 miles and uses 12 gallons of gas. How many miles per gallon is that?
55. *Finding the weekly salary* A teacher makes \$31,200 annually. What is the weekly salary? (There are 52 weeks in a year.)
56. *Cost per credit hour* A part-time student in a community college paid \$156 for tuition. The student was taking 3 credit hours. What was the cost of each credit hour?
57. *BTUs for 100-watt bulb* One 100-watt bulb burning for 10 hours uses 11,600 Btu. How many Btu per hour does the bulb burn?
58. *Running out of gas* The United States uses 23 trillion cubic feet of natural gas each year. The reserves of natural gas are 253 trillion cubic feet. If no more gas is discovered, how many more years will it take before we run out of natural gas?
59. *Words per minute in shorthand* The fastest recorded shorthand writing speed under championship conditions is 1500 words in 5 minutes. How many words per minute is that?
60. *Pay per word* One of the highest rates ever offered to a writer was \$30,000 to Ernest Hemingway for a 2000-word article on bullfighting. How much was he paid per word?

Monthly expenses In Problems 61–64 find the **monthly** expense for each of the categories.

	Category	Annual (12-Month) Expenditures
61.	Apparel and services	\$1368
62.	Entertainment	\$1164
63.	Housing	\$7656
64.	Personal Care Products	\$336

Source: Bureau of Labor Statistics, Consumer Expenditure Survey for persons under 25 <http://data.bls.gov/PDQ/outside.jsp?survey=cx>.

>>> Applications: Green Math

65. *Paper use* Americans use over 180,000 million pounds of paper per year. If we assume that there are 300 million Americans, how many pounds per person is that?
66. *Replacing paper towels* If every family in the United States replaced one 70-sheet roll of paper towels with a reusable alternative, it could save 6,528,000 trees per year. How many trees are saved per month?
67. *Paper use by teachers* In South Florida classrooms, paper is becoming a relic. The result: homework online, paperless term papers, and courses on compact discs. Mark Strauss, a principal in Fort Lauderdale, keeps track of how many copies teachers make. Those who exceed 24,000 in a year are urged to reconsider their paper-dependent ways.
68. *Cutting your shower short* If you cut your daily shower by a mere 2 minutes, you will save 1825 gallons of water per year.
- a. How many gallons per day is that? Assume there are 365 days in a year.
- b. How many gallons are saved daily if all the members of a family of four cut their shower by 2 minutes? How many gallons a year is that?
- a. How many copies per month is that?
- b. If a teacher works 120 days in the school year, how many copies per day is that?

Using Your Knowledge

An Average Problem The idea of an **average** is used in many situations. The average (mean) is the result obtained by dividing the sum of two or more quantities by the number of quantities. For example, if you have taken three tests and your scores were 90, 72, and 84, your average for the three tests is:

$$\begin{array}{l} \text{Sum of the scores} \rightarrow \frac{90 + 72 + 84}{3} = \frac{246}{3} = 82 \\ \text{Number of tests} \rightarrow \end{array}$$

Thus, the average for the three tests is 82.

The accompanying table shows the average income for a person with different numbers of years of schooling. For example, the average income for a person with a master's degree is obtained by dividing the *life income*, \$2,500,000, by the *number of years the average person receives income*, 40.

$$\begin{array}{l} \text{Income} \rightarrow \frac{2,500,000}{40} = \$62,500 \\ \text{Years} \rightarrow \end{array}$$

Thus, the average income is \$62,500

Years of School	Average Income	Life (40-yr) Income
Master's	\$62,500	\$2,500,000
Bachelor's	<input type="text"/>	2,100,000
Associate	<input type="text"/>	<input type="text"/>
Some College	<input type="text"/>	<input type="text"/>
High School	<input type="text"/>	<input type="text"/>
No High School	<input type="text"/>	<input type="text"/>

**Work Life (40 years) Earnings Estimates
(in Millions) for Full-Time Year-Round
Workers by Educational Attainment**

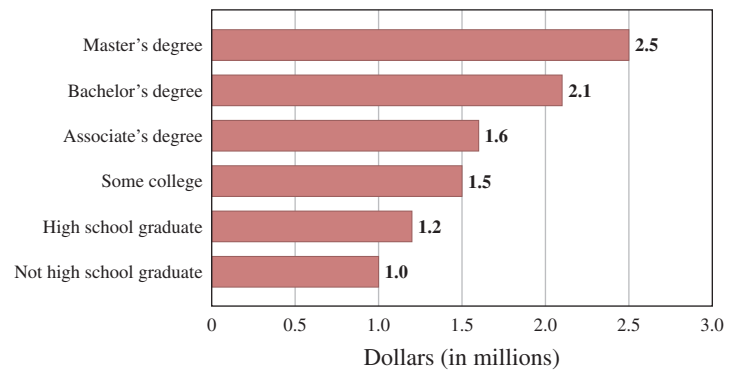

- 69.** Find the average income for a person with a bachelor's degree.
- 70.** Find the average income for a person with an associate's degree.
- 71.** Find the average income for a person with some college education.
- 72.** Find the average income for a high school graduate.
- 73.** Find the average income for a person who is not a high school graduate.
- 74.** What is the average number of calories in a hamburger? Estimate the answer using the following information:
- | | |
|-------------|--------------|
| Burger King | 275 calories |
| Dairy Queen | 360 calories |
| Hardee's | 275 calories |
| McDonald's | 265 calories |
| Wendy's | 350 calories |
- 75.** A person earned \$250, \$210, \$200, and \$240 during the four weeks of a certain month. What was the average weekly salary?
- 76.** The weight of the players in the defensive line of a football team is as follows: 240, 237, 252, and 263. What is the average weight of these players?
- 77.** The price of a certain stock during each day of last week was as follows: \$24, \$25, \$24, \$26, \$26. What was the average price of the stock?
- 78.** The ages of the players on a basketball team are as follows: 18, 17, 20, 18, 17. What is the average age of the players on this team?

>>> Write On

- 79.** Look at the definition of division and write the procedure you use to check a division problem using multiplication. Make sure the procedure includes the instances in which there is a remainder.
- 80.** If you divide a number by itself, the answer is 1. Write in your own words why this rule does not work when you divide 0 by 0.
- 81.** Explain in your own words why division by 0 is not defined.
- 82.** Is division commutative? Why or why not? Give examples.

>>> Concept Checker

Fill in the blank(s) with the correct word(s), phrase, or mathematical statement.

- 83.** The **quotient** $a \div b$ ($b \neq 0$) is the unique whole number c so that _____.
- 84.** When we write $20 \div 5 = 4$, 20 is called the _____, 5 is the _____, and 4 is the _____.
- 85.** **Multiplication** is the _____ process of division.
- 86.** $a \div a =$ _____ ($a \neq 0$).
- 87.** $a \div 1 =$ _____.
- 88.** $0 \div a =$ _____ ($a \neq 0$).

divisor	0
1	inverse
$a = b \times c$	quotient
$c = a \times b$	a
dividend	$b = a \times c$

>>> Mastery Test

- 89.** Write as a multiplication problem and find the answer if possible.
- a.** $48 \div 6 = \square$
- b.** $37 \div 1 = \square$
- 91.** Write as a multiplication problem and find the answer if possible.
- a.** $9 \div 9 = \square$
- b.** $7 \div 1 = \square$
- 93.** Divide using long division. (Show the remainder if there is one.)
- a.** $792 \div 6 = \underline{\hspace{2cm}}$ **b.** $1728 \div 9 = \underline{\hspace{2cm}}$
- 90.** Write as a multiplication problem and find the answer if possible.
- a.** $0 \div 8 = \square$
- b.** $8 \div 0 = \square$
- 92.** Write as a multiplication problem and find the answer if possible.
- a.** $99 \div 9 = \square$
- b.** $9 \div 3 = \square$
- 94.** A person earns \$27,600 annually. How much does the person earn each month?

>>> Skill Checker

Fill in with $<$ or $>$ to make the resulting inequality true.

95. $345 \underline{\hspace{2cm}} 354$

96. $908 \underline{\hspace{2cm}} 809$

Multiply:

97. 305×1003

98. 908×1203

1.7

Primes, Factors, and Exponents

▶ Objectives

You should be able to:

- A > Determine if a number is prime or composite.
- B > Find the prime factors of a number.
- C > Write a number as a product of primes, using exponential notation if necessary.
- D > Write two or more numbers containing exponents as a product and then find the product.

▶ To Succeed, Review How To . . .

1. Use the multiplication facts. (p. 51)
2. Apply the meaning of the word *factor*. (p. 51)

▶ Getting Started

Look at the numbers in the blue boxes (2, 3, 5, and so on). They are **prime numbers**. The spiral was constructed by arranging the counting numbers in a counterclockwise fashion and placing the numbers with exactly two factors (themselves and 1) in a blue box. As you can see, the prime numbers tend to form diagonal lines. Why? Nobody knows!

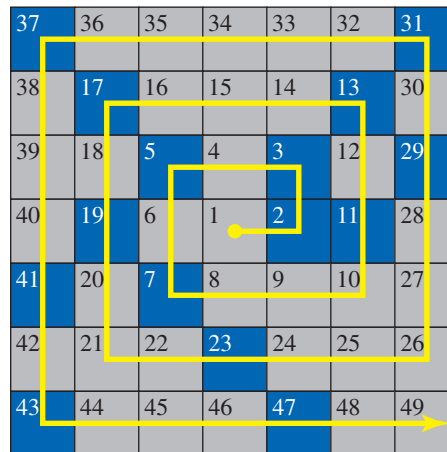

A > Primes and Composites

As you recall from Section 1.5, when a number is written as the product of other numbers, these other numbers are called **factors**. Thus, 2 and 3 are factors of 6 because $6 = 2 \times 3$. Note that 2×3 is an example of a **factorization** of 6. Similarly, 1 and 6 are factors of 6 because $6 = 1 \times 6$.

PRIME NUMBER

A **prime number** is a counting number having exactly *two different* factors, itself and 1.

Here are the first few counting numbers written as products of factors:

$$\begin{array}{ll}
 1 = 1 \times 1 & 4 = 1 \times 4 \text{ or } 2 \times 2 \\
 2 = 1 \times 2 & 5 = 1 \times 5 \\
 3 = 1 \times 3 & 6 = 1 \times 6 \text{ or } 2 \times 3
 \end{array}$$

As you can see:

1 has only one factor: 1

2 has two factors: 1 and 2

3 has two factors: 1 and 3

4 has three factors: 1, 2, and 4

5 has two factors: 1 and 5

6 has four factors: 1, 2, 3, and 6

Recall that $4 = 1 \times 4$ and 2×2 ,
 $6 = 1 \times 6$ and 2×3 .

Since a number is prime when it has exactly two *distinct* factors, itself and 1, the prime numbers in the list above are 2, 3, and 5. The other numbers (1, 4, 6) are **not prime**. Note that 1 is *not* prime because it does not have two *distinct* factors.

COMPOSITE NUMBER

A counting (natural) number greater than 1 that is **not prime** is said to be **composite**.

Thus, in the preceding list, 4 and 6 are composite.

EXAMPLE 1 Finding if a number is prime or composite

Determine if the given numbers are prime or composite.

a. 14

b. 17

SOLUTION 1

- a. 14 has more than two factors since $14 = 1 \times 14$ or 2×7 . Thus, 14 is composite.
- b. $17 = 1 \times 17$. Since 17 has *exactly* two factors, itself and 1, 17 is a prime number.

PROBLEM 1

Determine if the given numbers are prime or composite.

a. 19

b. 15

B > Finding Prime Factors

In Example 1 we noticed that 14 is a composite number with four factors (1, 2, 7, 14), two of which (2 and 7) are prime. The *prime* factors of a number are those factors that are prime. For example, the factors of 18 are 1, 2, 3, 6, 9, and 18, but the **prime factors** of 18 are 2 and 3. The numbers 1, 6, 9, and 18 are *not* prime and thus cannot be prime factors of 18.

EXAMPLE 2 Finding prime factors

Find the prime factors of these numbers.

a. 10

b. 11

SOLUTION 2

- a. $10 = 1 \times 10$ or 2×5 . Thus the factors of 10 are 1, 2, 5, and 10. Of these, 2 and 5 are prime factors.
- b. $11 = 1 \times 11$. Thus 11 has only one prime factor, 11. Any prime number has only one prime factor, itself.

PROBLEM 2

Find the prime factors of these numbers.

a. 13

b. 12

It is easy to find the prime factors of 10 because 10 is a small number. How can we find the prime factors of larger numbers? To do this we first need to know if the given number is prime. Unfortunately, nobody has discovered a simple formula for finding all prime numbers. However, a Greek mathematician named Eratosthenes invented a

Answers to PROBLEMS

1. a. prime b. composite

2. a. 13 b. 2 and 3

procedure to find all prime numbers smaller than a given number—say 50. He listed all the numbers 1 through 50 in a table, as shown here:

Sieve of Eratosthenes									
1	②	③	4	⑤	6	⑦	8	9	10
⑪	12	⑬	14	15	16	⑰	18	⑲	20
21	22	⑳	24	25	26	27	28	㉑	30
⑳	32	33	34	35	36	㉗	38	39	40
㉒	42	㉔	44	45	46	㉙	48	49	50

He then reasoned as follows: The number 1 is not a prime (it has only one factor), so he marked it out. He then concluded that 2 is a prime, but any number with 2 as a factor (4, 6, 8, etc.) is composite. He then circled 2 as a prime and crossed out 4, 6, 8, and so forth. Next, since 3 is a prime, he circled it and crossed out all numbers having 3 as a factor, starting with 9 (6 was already out). Similarly, he circled 5 (the next prime) and crossed out the numbers having 5 as a factor, starting with 25 (10, 15, and 20 were already out). He continued this process until he reached 11, noting that all the numbers having 11 as a factor (2×11 , 3×11 , and 4×11) had been eliminated when he had crossed out the numbers having factors of 2 and 3. Hence, all the numbers that are left are prime. They are circled and set in color in the table.

C > Writing Composite Numbers as Products of Primes

Now we are ready to write a composite number as a product of primes; that is, to find the prime factorization of a number (a procedure that is necessary to reduce and add fractions). This is done by dividing by the first few primes, 2, 3, 5, 7, 11, and so on. To help you in this process, we give the rules that will tell you if a number is divisible by 2, 3, and 5. (There are rules to tell if a number is divisible by 7 or 11, but they are so complicated that you may as well try dividing by 7 or 11. The Using Your Knowledge section has additional divisibility rules.)

RULE TO TELL IF A NUMBER IS DIVISIBLE BY 2

A number is divisible by 2 if it ends in an even number (2, 4, 6, 8, or 0).

For example, 42, 68, and 90 are divisible by 2. When a number is divisible by 2, it is called an **even** number, so 42, 68, and 90 are even. If a whole number is *not* even (not divisible by 2) it is called an **odd** number. Thus, 43, 71, and 95 are odd.

RULE TO TELL IF A NUMBER IS DIVISIBLE BY 3

A number is divisible by 3 if the sum of its digits is divisible by 3.

Thus, 273 is divisible by 3 because the sum of its digits (12) is divisible by 3 as shown:

$$\begin{array}{ccc} 2 & 7 & 3 \\ \downarrow & \downarrow & \downarrow \\ 2 + 7 + 3 = 12 & & \text{(divisible by 3)} \end{array}$$

RULE TO TELL IF A NUMBER IS DIVISIBLE BY 5

A number is divisible by 5 if it ends in 0 or 5.

For example, 300 and 95 are divisible by 5. Note that the divisibility rules for 4, 6, 8, 9, and 10 are given in Exercises 65–69.

We will use these divisibility tests to help us write a composite number as a product of primes. This is called prime factorization. Let us try to write 24 as a product of primes; that is, find the prime factorization of 24. To do so, we divide by successive primes (2, 3, 5, and so on).

Divide 24 by 2 (the first prime).	$\rightarrow 2 \overline{)24}$
Divide 12 by 2.	$\rightarrow 2 \overline{)12}$
Divide 6 by 2.	$\rightarrow 2 \overline{)6}$
3 cannot be divided by 2, so we divide by the next prime, 3.	$\rightarrow 3 \overline{)3}$
	1

Thus,

$$24 = 2 \times 2 \times 2 \times 3$$

You can also use a factor tree and still divide by successive primes, as follows:

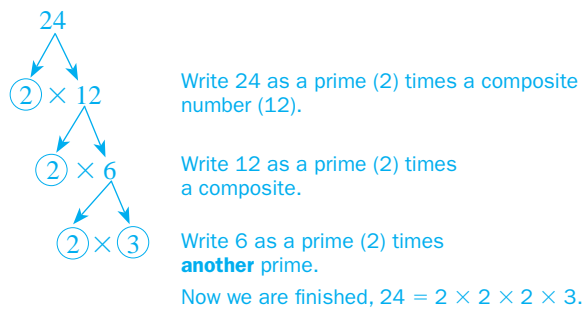

Note: You can also use a dot (\cdot) and write $24 = 2 \cdot 2 \cdot 2 \cdot 3$. In this section, we will use the multiplication sign (\times) to indicate a multiplication.

What about trying to write 79 as a product of primes? We do this by dividing by successive primes (2, 3, 5, etc.) if possible.

79 is not divisible by 2 (it ends in 9).

79 is not divisible by 3 ($7 + 9 = 16$, which is not divisible by 3).

79 is not divisible by 5.

79 is not divisible by 7. If we divide 79 by 7 we have a remainder of 2.

$$\begin{array}{r} 11 \\ 7 \overline{)79} \\ \underline{-7} \\ 09 \\ \underline{-7} \\ 2 \leftarrow \text{Remainder} \end{array}$$

79 is not divisible by 11. If we divide 79 by 11 we have a remainder of 2.

$$\begin{array}{r} 7 \\ 11 \overline{)79} \\ \underline{-77} \\ 2 \leftarrow \text{Remainder} \end{array}$$

Note that we can stop dividing here because dividing by 11 gives a quotient (7) less than the divisor (11). In general, when testing to see if a number is prime, you can stop dividing *when the quotient is less than the divisor*. Since 79 is *not* divisible by any of our prime divisors, 79 is a *prime* number.

EXAMPLE 3 Prime factorization: Writing as product of primes

Write (if possible) the given number as a product of primes.

- a. 45 b. 89 c. 32

SOLUTION 3

a. We must divide by the first few primes, 2, 3, 5, 7, and so on. Since 45 is not divisible by 2, we start by dividing by 3 as shown:

$$\begin{array}{l} \text{Divide by 3.} \quad \rightarrow 3 \overline{)45} \\ \text{Divide by 3.} \quad \rightarrow 3 \overline{)15} \\ \text{Divide by 5.} \quad \rightarrow 5 \overline{)5} \\ \quad\quad\quad\quad\quad\quad\quad 1 \end{array}$$

Thus,

$$45 = 3 \times 3 \times 5$$

The factor tree is

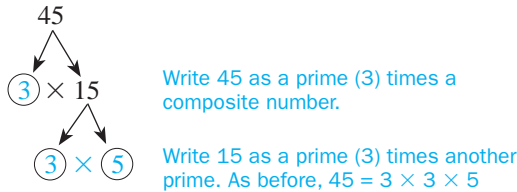

b. We try to divide by successive primes.

- 89 is not divisible by 2 (it ends in 9).
- 89 is not divisible by 3 ($8 + 9 = 17$, which is not divisible by 3).
- 89 is not divisible by 5.
- 89 is not divisible by 7.

$$\begin{array}{r} 12 \\ 7 \overline{)89} \\ -7 \\ \hline 19 \\ -14 \\ \hline 5 \leftarrow \text{Remainder} \end{array}$$

89 is not divisible by 11.

$$\begin{array}{r} 8 \\ 11 \overline{)89} \\ -88 \\ \hline 1 \leftarrow \text{Remainder} \end{array}$$

Since the quotient (8) is smaller than the divisor (11), we can stop here. Because 89 is not divisible by any of our prime divisors, we can say that 89 is a **prime number**.

- c. Divide by 2. $\rightarrow 2 \overline{)32}$
 Divide by 2. $\rightarrow 2 \overline{)16}$
 Divide by 2. $\rightarrow 2 \overline{)8}$ or
 Divide by 2. $\rightarrow 2 \overline{)4}$
 Divide by 2. $\rightarrow 2 \overline{)2}$
 1

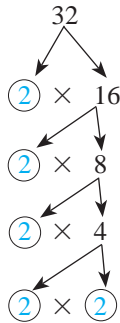

Thus,

$$32 = 2 \times 2 \times 2 \times 2 \times 2$$

PROBLEM 3

Prime factorization: Write (if possible) the given number as a product of primes.

- a. 35 b. 16 c. 97

Answers to PROBLEMS

3. a. 5×7 b. $2 \times 2 \times 2 \times 2$
 c. Prime

Products like $2 \times 2 \times 2 \times 2 \times 2$ are easier to write using **exponential notation**. Using this notation, we write

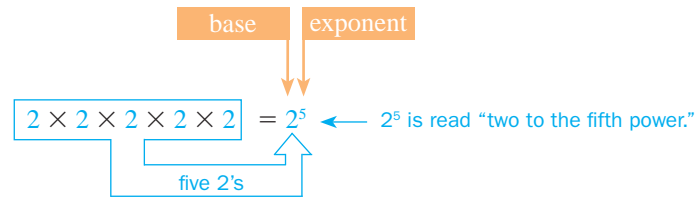

$$2 \times 2 \times 2 \times 2 \times 2 = 2^5$$

← 2^5 is read "two to the fifth power."

Here 2 is called the **base** and 5 is called the **exponent**. The exponent 5 tells us how many times the base 2 must be used as a factor. Similarly,

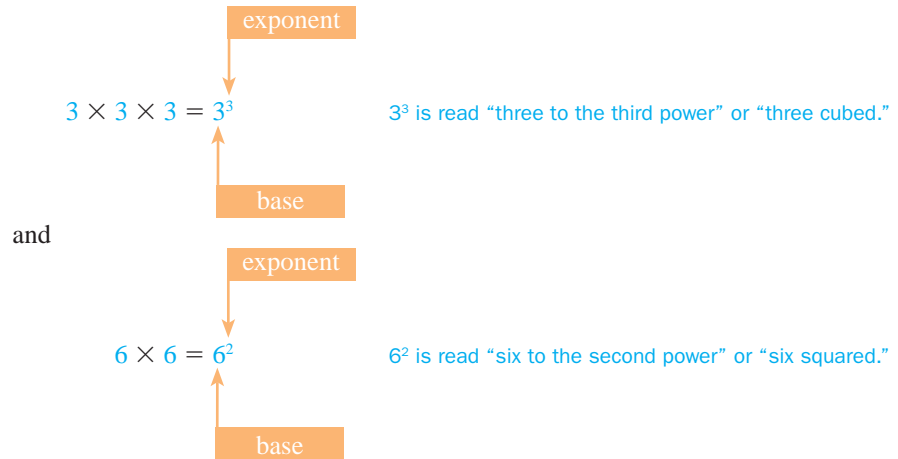

$$3 \times 3 \times 3 = 3^3$$

3^3 is read "three to the third power" or "three cubed."

and

$$6 \times 6 = 6^2$$

6^2 is read "six to the second power" or "six squared."

EXAMPLE 4 Prime factorization: writing numbers with exponential notation

Use exponential notation to write the given number as a product of primes.

a. 18

b. 72

SOLUTION 4

a. Divide by 2 $\rightarrow 2 \overline{)18}$

$$\text{Divide by 3} \rightarrow 3 \overline{)9} \quad \frac{18}{2} = 9$$

$$\text{Divide by 3} \rightarrow 3 \overline{)3} \quad \frac{9}{3} = 3$$

$$1 \quad \frac{3}{3} = 1$$

Thus,

$$18 = 2 \times 3 \times 3 = 2 \times 3^2$$

b. Divide by 2 $\rightarrow 2 \overline{)72}$

$$\text{Divide by 2} \rightarrow 2 \overline{)36} \quad \frac{72}{2} = 36$$

$$\text{Divide by 2} \rightarrow 2 \overline{)18} \quad \frac{36}{2} = 18$$

$$\text{Divide by 3} \rightarrow 3 \overline{)9} \quad \frac{18}{2} = 9$$

$$\text{Divide by 3} \rightarrow 3 \overline{)3} \quad \frac{9}{3} = 3 \text{ and } \frac{3}{3} = 1$$

1

Thus,

$$72 = 2 \times 2 \times 2 \times 3 \times 3 = 2^3 \times 3^2$$

$2^3 \times 3^2$ is read "2 cubed times 3 squared."

PROBLEM 4

Prime factorization: use exponential notation to write the given number as a product of primes.

a. 27

b. 98

Answers to PROBLEMS

4. a. 3^3 b. 2×7^2

D > Products Involving Exponents

Sometimes we are given a number such as $2^2 \times 3^2$ and we want to write the answer in standard notation. Thus,

$$2^2 \times 3^2 = 2 \times 2 \times 3 \times 3 = 36$$

EXAMPLE 5 Prime factorization: finding products involving exponents

Write the given numbers as a product of factors; then find the product.

a. $2^3 \times 3^2$

b. $2^2 \times 5^3$

SOLUTION 5

a. $2^3 \times 3^2 = (2 \times 2 \times 2) \times (3 \times 3) = 8 \times 9 = 72$

b. $2^2 \times 5^3 = (2 \times 2) \times (5 \times 5 \times 5) = 4 \times 125 = 500$

PROBLEM 5

Prime factorization: find the products by writing as a product of factors.

a. $2^2 \times 3^3$

b. $2^3 \times 5^2$

Now look at this pattern.

$$10^5 = 100,000$$

$$10^4 = 10,000$$

$$10^3 = 1000$$

$$10^2 = 100$$

$$10^1 = \underline{\quad ? \quad}$$

$$10^0 = \underline{\quad ? \quad}$$

Here, the exponent of a number whose base is 10 tells us how many zeros there are in the final product. Can you now find the values of 10^1 and 10^0 ? Since the exponent tells us the number of zeros, we have

$$10^1 = 10 \quad \text{and} \quad 10^0 = 1$$

In general, for any number a , we define

$$a^1 = a$$

$$a^0 = 1, a \neq 0$$

Thus, $2^1 = 2$, $3^1 = 3$, $2^0 = 1$, and $3^0 = 1$.

EXAMPLE 6 Prime factorization: finding products involving exponents

Write these as a product of factors, then find the product.

a. $3^2 \times 2^1$

b. $5^2 \times 2^3 \times 7^0$

SOLUTION 6

a. $3^2 \times 2^1 = 9 \times 2 = 18$

b. $5^2 \times 2^3 \times 7^0 = 25 \times 8 \times 1 = 200$

PROBLEM 6

Prime factorization: find the products by writing as a product of factors.

a. $3^1 \times 4^2$

b. $2^2 \times 3^0 \times 5^3$

Often, we have to derive an approximate result from insufficient or even conflicting data. *Guesstimation*, a book by Lawrence Weinstein and John A. Adams, shows you how to do just that. As one of the reviewers says: *Guesstimation* is a book that unlocks the power of approximation—it is popular mathematics rounded to the nearest power of ten! (Which is the subject of our discussion!) Two “guesstimations” are used in Example 7.

Answers to PROBLEMS

5. a. 108 b. 200

6. a. 48 b. 500

GREEN MATH

EXAMPLE 7 A lot of trash

How much trash do you produce every day? It should be between 4 and 5 pounds, but the whole country produces 2×10^8 tons of trash per year. Write 2×10^8 as a standard numeral and in words.

SOLUTION 7 $2 \times 10^8 = 2 \times 100,000,000 = 200,000,000$, that is, two hundred million tons of trash per year.

PROBLEM 7

The volume of the trash produced in the United States every year is 3×10^8 cubic meters per year. (A cubic meter is a cube one meter on each side.) Write 3×10^8 as a standard numeral and in words.

Calculator Corner

We can easily determine if a number is prime using a calculator. We simply divide the number by the first few primes. Thus, to determine if 79 is prime, we divide 79 by 2, 3, 5, 7, and 11. Since none of the divisions is exact, 79 is a prime number.

Regarding multiplying factors involving exponents, we can proceed two ways:

Method 1. By repeated multiplications.

Method 2. By using the y^x key, if your calculator has one.

Thus, to multiply $2^3 \times 3^2$ (as in Example 5), we can proceed as follows:

Method 1. $2^3 \times 3^2 = 2 \times 2 \times 2 \times 3 \times 3$ ENTER 72

Method 2. If you have a y^x key, you can find 2^3 first by pressing 2 y^x 3 ENTER. The display will show 8. To multiply this answer by 3^2 , key in \times 3 y^x 2 ENTER. As before, the answer will be 72. The complete sequence is 2 y^x 3 ENTER \times 3 y^x 2 ENTER.

> Exercises 1.7



> Practice Problems > Self-Tests
> Media-rich eBooks > e-Professors > Videos

< **A** > **Primes and Composites** In Problems 1–10, determine if the number is prime or composite. If composite, list *all* its factors.

- | | | | |
|-------|--------|-------|-------|
| 1. 7 | 2. 28 | 3. 6 | 4. 17 |
| 5. 24 | 6. 8 | 7. 25 | 8. 26 |
| 9. 23 | 10. 30 | | |

< **B** > **Finding Prime Factors** In Problems 11–20, find the *prime* factors of each number.

- | | | | | |
|--------|--------|--------|--------|--------|
| 11. 14 | 12. 16 | 13. 18 | 14. 23 | 15. 29 |
| 16. 30 | 17. 22 | 18. 20 | 19. 21 | 20. 31 |

< **C** > **Writing Composite Numbers as Products of Primes** In Problems 21–30, write each number as a product of primes using exponents. If the number is prime, indicate so.

- | | | | | |
|--------|--------|---------|---------|---------|
| 21. 34 | 22. 31 | 23. 41 | 24. 48 | 25. 64 |
| 26. 81 | 27. 91 | 28. 110 | 29. 190 | 30. 200 |

Answers to PROBLEMS

7. 300,000,000, that is, three hundred million cubic meters per year

< D > Products Involving Exponents In Problems 31–40, find the product by writing as a product of factors.

31. $3^0 \times 2^2$ 32. $10^3 \times 2^2$ 33. $2^0 \times 10^0$ 34. $4^2 \times 3^1$ 35. $5^2 \times 2^2$
 36. $2^2 \times 5^0 \times 3^2$ 37. $4^3 \times 2^1 \times 4^0$ 38. $10^0 \times 3^2 \times 10^3$ 39. $5^2 \times 2^3 \times 11^0$ 40. $2^3 \times 5^2 \times 6^1$

>>> Applications

41. *Prime numbers less than 50* How many prime numbers are less than 50?
42. *Prime number between 50 and 100* How many prime numbers are between 50 and 100? (*Hint:* Use a sieve of Eratosthenes.)
43. *Cell phones and exponents* At the end of 2005, the number of worldwide cell phone subscribers was 2,000,000,000. Write this number as a product using exponents.
44. *Alaskan oil reserves* The proved Alaskan oil reserves are 5,000,000,000 barrels. Write this number as a product by using exponents.
45. *Folding paper* Take a sheet of notebook paper. If you fold it in half once, it is 2 layers thick. If you fold it in half again, it is 4 layers thick. If you fold it in half another time, it is 8 layers thick. Here is the table relating the number of folds and the number of layers thick. Complete this table.

Number of Folds	Number of Layers Thick
0	$2^0 = 1$
1	$2^1 = 2$
2	$2^2 = 4$
3	$2^3 = 8$
4	$2 =$
5	$2 =$

46. *Patterns in paper folding* Is there a pattern for finding the number of layers thick by using exponents for 2? If so, how many layers thick will it be after:
- 6 folds?
 - 10 folds?
47. *Pioneer journey* *Pioneer 10*, a crewless U.S. spacecraft, was launched March 2, 1972, on a 639-day, 1,000,000,000-kilometer journey past Jupiter. Write this distance using exponents.
48. *Hemoglobin in red blood cells* A red blood cell contains about 3×10^8 hemoglobin molecules. Write this number as a product of factors and multiply out.
49. *Distance to Milky Way* Our solar system is 3×10^4 light-years from the center of the Milky Way galaxy. Write 3×10^4 as a product of factors and multiply out.
50. *Light-years to Milky Way* A light-year (the distance light travels in 1 year at 186,000 miles per second) is 6×10^{12} miles. Since we are 3×10^4 light-years from the center of the Milky Way, our distance from this center is $(3 \times 10^4) \times (6 \times 10^{12})$ miles. Write this number as a product of factors and multiply out.
51. *Letters in a manuscript* A typical typed page of text contains about $3000 = 3 \times 10^3$ letters. Thus, a 500-page manuscript will have $(5 \times 10^2) \times (3 \times 10^3)$ letters. Write this number as a product of factors and multiply.
52. *Hamburger revenue* A large hamburger costs $(\$3 \times 10^0)$. If 2 million $(= 2 \times 10^6)$ of these burgers are sold, the revenue would be $(\$3 \times 10^0) \times (2 \times 10^6)$. Write this number as a product of factors and multiply.
53. *0's in a googol* The definition of a googol is: **1 googol = 10^{100}** . How many 0's are in a googol? *Hint:* 10^2 has 2 zeros, 10^3 has 3 zeros.
54. *Exponents* If a **googolplex = 10^{googol}** , write a googolplex using powers of 10.

>>> Applications: Green Math

Problems 55–60 use data from *Guesstimation* but to understand some of the data, you have to understand some of the terminology:

Watt (W): the amount of power a device uses in performing its function (your computer uses about 130 watts when it is on).

GW: A gigawatt, equivalent to 10^9 watts.

Kilogram (kg): about 2.20 pounds.

Joule (J): the standard unit of energy, equivalent to 1 watt of power used or dissipated for 1 second.

55. *Electrical power* How much electrical power do you use? Your cable box uses 25 watts and your television 100. The total electrical power used in the United States in one year is 5×10^{11} watts. Write 5×10^{11} in standard form and in words.
56. *Nuclear power* If we add electricity generated by nuclear plants, the total electrical energy used in the United States in 1 year is 3×10^{19} joules. Write 3×10^{19} in standard form and in words.

- 57. Solar energy** We can also use solar energy, but we will need lots of land to place our solar panels to get the energy needed. Do you know how much land? 4×10^4 km² (km² is a square 1 kilometer on a side). Write 4×10^4 in standard form and in words.
- 58. Coal power** What if we use coal? How much coal does a one-GW (gigawatt) coal-fired electrical power plant require in 1 year? 5×10^4 kilograms per year! Write 5×10^4 in standard form and in words.
- 59. Back to nuclear** How much fuel does that one-GW nuclear power plant require in 1 year? The answer is 2×10^4 kg/year of 5% enriched uranium. Write 2×10^4 in standard form and in words.
- 60. Wind turbine** What if we used wind turbines, giant windmills that generate electricity? If the wind is blowing at 10 meters per second (about 20 mph) and the length of the blades is 40 meters, the available power from the turbine is 3×10^5 W. Write 3×10^5 in standard form and in words.

Using Your Knowledge

Divide and Conquer (Prime Factorization) To write a number as a product of primes, you have to divide the number by 2, 3, 5, 7, and so on. We restate the rules to tell, without dividing, if a number is divisible by 2, 3, or 5.

- 61.** A number is divisible by 2 if its last digit is 2, 4, 6, 8, or 0. Are these numbers divisible by 2?
a. 12 **b.** 13 **c.** 20
- 62.** A number is divisible by 3 if the sum of its digits is divisible by 3. For example, 462 is divisible by 3 because $4 + 6 + 2 = 12$, which is divisible by 3. Are these numbers divisible by 3?
a. 493 **b.** 112 **c.** 111
- 63.** A number is divisible by 5 if its last digit is 5 or 0. Are these numbers divisible by 5?
a. 125 **b.** 301 **c.** 240
- 64.** Use the information in problems 55, 56, and 57 to determine if the given numbers are divisible by 2, 3, or 5. (For example, 42 is divisible by 2 and 3, as indicated by the check marks.)

	Number	Divisible by		
		2	3	5
	42	✓	✓	
a.	24			
b.	50			
c.	19			
d.	30			
e.	91			

- 65. Divisibility by 4** A number is divisible by 4 if the number created by the last two digits in the number is divisible by 4. For example, 384 is divisible by 4, since the last two digits in the number form the number 84, which is divisible by 4. On the other hand, the number 319 is *not* divisible by 4, since the last two digits form the number 19, which is not divisible by 4. Are these numbers divisible by 4?
a. 420 **b.** 308
c. 1234 **d.** 1236
- 66. Divisibility by 6** A number is divisible by 6 if it is divisible by 2 and 3. Thus, 234 is divisible by 6 because 234 is divisible by 2 and by 3 ($2 + 3 + 4 = 9$, which is divisible by 3, so 234 is divisible by 3). On the other hand, 368 is *not* divisible by 6 because 368 is divisible by 2 but not by 3 ($3 + 6 + 8 = 17$, which is not divisible by 3). Are these numbers divisible by 6?
a. 432 **b.** 315
c. 3126 **d.** 4123
- 67. Divisibility by 8** A number is divisible by 8 if the number formed by the last three digits in the number is divisible by 8. For example, 3416 is divisible by 8 because the last three digits in the number form the number 416, which is divisible by 8. On the other hand, the number 1319 is *not* divisible by 8, since the last three digits form the number 319, which is not divisible by 8. Are these numbers divisible by 8?
a. 1424 **b.** 1630
c. 2360 **d.** 2148
- 68. Divisibility by 9** A number is divisible by 9 if the sum of the digits of the number is divisible by 9. This means that 342 is divisible by 9 since $3 + 4 + 2 = 9$, which is divisible by 9. However, 1352 is *not* divisible by 9, since $1 + 3 + 5 + 2 = 11$, which is not divisible by 9. Are these numbers divisible by 9?
a. 348 **b.** 564
c. 2386 **d.** 6570
- 69. Divisibility by 10** A number is divisible by 10 if it ends with a 0. Thus, 980 and 340 are divisible by 10, but 342 and 786 are not. Are these numbers divisible by 10?
a. 450 **b.** 432
c. 567 **d.** 980
- 70.** Christian Goldbach made a famous conjecture (guess) that has not yet been proved or disproved. He said that every even number greater than 2 can be written as the sum of two primes. For example,

$$4 = 2 + 2$$

$$6 = 3 + 3$$

$$8 = 3 + 5$$

Write each even number from 10 through 20 as the sum of two primes.

>>> Write On

- 71.** In 1771 Leonhard Euler, a Swiss mathematician, discovered the prime number $2^{31} - 1$. This is an example of a Mersenne prime, a prime of the form $2^p - 1$. The largest prime at this time is $2^{13466917} - 1$.
- Do you think this number is odd or even? Write the reasons.
 - How many digits do you think this prime has?
 - How many lines do you think it would take to type it?
- 72.** Do you think the number of primes is finite or infinite? Write your reasons.
- 73.** What is the difference between “the number of factors” of a number and “the number of prime factors” of a number? Explain and give examples.

>>> Concept Checker

Fill in the blank(s) with the correct word(s), phrase, or mathematical statement.

- | | | |
|--|----------------|----------------|
| 74. A number is divisible by 2 if it ends in an _____ number. | 1 | sum |
| 75. A number is divisible by 3 if the _____ of its digits is divisible by 3. | a | product |
| 76. A number is divisible by 5 if it ends in _____ or in _____. | factors | even |
| 77. A number is _____ if it is divisible by 2 . | 5 | 0 |
| 78. $a^1 =$ _____ ($a \neq 0$). | odd | |
| 79. $a^0 =$ _____ ($a \neq 0$). | | |

>>> Mastery Test

- 80.** Find the prime factors of 40.
- 81.** Determine if the following numbers are prime or composite:
- 41
 - 39
- 82.** Write 84 as a product of primes.
- 83.** Use exponents to write the number as a product of primes.
- 3600
 - 360
- 84.** Find the product: $2^4 \times 3^2$
- 85.** Find the product: $5^2 \times 2^2 \times 7^0$
- 86.** Find the product: $5^2 \times 2^2 \times 3^3$

>>> Skill Checker

In Section 1.1 we discussed how to write a number in expanded form. Thus, $387 = 300 + 80 + 7$. We can now write the expanded form using exponents. To do this, recall that $10^4 = 10,000$, $10^3 = 1,000$, $10^2 = 100$, $10^1 = 10$, and $10^0 = 1$. Thus,

$$387 = 3 \times 10^2 + 8 \times 10^1 + 7 \times 10^0$$

Write each number in expanded form using exponents.

- | | |
|-----------------|-----------------|
| 87. 138 | 88. 345 |
| 89. 1208 | 90. 3046 |

1.8

Order of Operations and Grouping Symbols

▶ Objectives

You should be able to:

- A** > Simplify expressions using the order of operations.
- B** > Remove grouping symbols within grouping symbols.
- C** > Solve applications using the concepts studied.

▶ To Succeed, Review How To . . .

1. Use arithmetic facts (+, −, ×, ÷). (pp. 24, 38, 51, 63)
2. Write a number containing exponents as a product and how to find this product. (p. 78)

▶ Getting Started

Suppose all 239 rooms in the motel are taken (for simplicity, do not include extra persons in the rooms). How can we figure out how much money we are going to collect? To do this, we *first* multiply the price of each room (\$24, \$28, and \$38) times the number of rooms (44, 150, 45). *Next*, we add all these figures and get the result. Note that we have *multiplied* before *adding*. (Did you get \$6966 for the answer?)

**A** > Order of Operations

If we want to find the answer to $3 \cdot 4 + 5$, do we (1) add 4 and 5 first and then multiply by 3, or (2) multiply 3 by 4 first and then add 5? In (1) the answer is 27. In (2) the answer is 17. What if we write $3 \cdot (4 + 5)$ or $(3 \cdot 4) + 5$? What do the parentheses mean? By the way, $3 \cdot (4 + 5)$ can also be written as $3(4 + 5)$ without the multiplication dot \cdot . To obtain an answer we can agree upon, we must make rules regarding the order in which we perform operations. The rules are as follows:

ORDER OF OPERATIONS

1. Do all calculations *inside* grouping symbols like parentheses (), brackets [], or braces { } first.
2. Evaluate all *exponential* expressions.
3. Do *multiplications* and *divisions* as they occur in order from left to right.
4. Do *additions* and *subtractions* as they occur in order from left to right.

You can remember this order if you remember the phrase PEMDAS.

Please	(parentheses)	←	Step 1.
Excuse	(exponential expressions)	←	Step 2.
My	(multiplication)	←	Step 3. If the multiplications occur first , do them first . If the divisions occur first , do the divisions first .
Dear	(division)	←	
Aunt	(addition)	←	Step 4. If the additions occur first , do them first . If the subtractions occur first , do the subtractions first .
Sally	(subtraction)	←	

Note that using **step 3** $8 \cdot 4 \div 2 = 32 \div 2 = 16$. When done *in order* from left to right multiplication was done *before* division, because the multiplication occurs before the division.

With these conventions:

$$\begin{aligned} 3 \cdot 2^2 + 5 &= 3 \cdot 4 + 5 && \text{Do exponents } (2^2 = 2 \cdot 2 = 4). \\ &= 12 + 5 && \text{Multiply } (3 \cdot 4 = 12). \\ &= 17 && \text{Add } (12 + 5 = 17). \end{aligned}$$

Similarly,

$$\begin{aligned} 3 \cdot (2^2 + 5) &= 3(4 + 5) && \text{To add inside parentheses, first do} \\ & && \text{exponents } (2^2 = 2 \cdot 2 = 4). \\ &= 3 \cdot 9 && \text{Add inside parentheses } (4 + 5 = 9). \\ &= 27 && \text{Multiply 3 by 9.} \end{aligned}$$

But

$$\begin{aligned} (3 \cdot 2^2) + 5 &= (3 \cdot 4) + 5 && \text{To multiply inside parentheses,} \\ & && \text{first do exponents } (2^2 = 2 \cdot 2 = 4). \\ &= 12 + 5 && \text{Multiply inside parentheses } (3 \cdot 4 = 12). \\ &= 17 && \text{Add } (12 + 5 = 17). \end{aligned}$$

EXAMPLE 1 Simplifying numerical expressions

Simplify.

a. $8 \cdot 3^2 - 3$

b. $3^3 + 3 \cdot 5$

SOLUTION 1

a. $8 \cdot 3^2 - 3 = 8 \cdot 9 - 3$ Do exponents ($3^2 = 3 \cdot 3 = 9$).
 $= 72 - 3$ Do multiplications and divisions in order from left to right
 $= 69$ Do additions and subtractions in order from left to right
 $(72 - 3 = 69)$.

b. $3^3 + 3 \cdot 5 = 27 + 3 \cdot 5$ Do exponents ($3^3 = 3 \cdot 3 \cdot 3 = 27$).
 $= 27 + 15$ Do multiplications and divisions in order from left to right
 $= 42$ Do additions and subtractions in order from left to right
 $(27 + 15 = 42)$.

PROBLEM 1

Simplify.

a. $7 \cdot 2^3 - 7$

b. $23 + 2^2 \cdot 5$

EXAMPLE 2 Simplifying numerical expressions

Simplify.

a. $63 \div 7 - (2 + 3)$

b. $8 \div 2 \cdot 2 \cdot 2 + 3 - 1$

PROBLEM 2

Simplify.

a. $48 \div 6 - (3 + 1)$

b. $10 \div 2 \cdot 2 \cdot 2 + 2 - 1$

Answers to PROBLEMS

1. a. 49 b. 43 2. a. 4 b. 21

SOLUTION 2

$$\begin{aligned} \text{a. } 63 \div 7 - (2 + 3) &= 63 \div 7 - 5 && \text{Do the operations inside parentheses first} \\ & && (2 + 3 = 5). \\ &= 9 - 5 && \text{Do multiplications and divisions } (63 \div 7 = 9). \\ &= 4 && \text{Do additions and subtractions } (9 - 5 = 4). \end{aligned}$$

$$\begin{aligned} \text{b. } 8 \div 2 \cdot 2 \cdot 2 + 3 - 1 &= 4 \cdot 2 \cdot 2 + 3 - 1 && \text{Divide 8 by 2.} \\ &= 16 + 3 - 1 && \text{Do multiplications } (4 \cdot 2 \cdot 2 = 16). \\ &= 19 - 1 && \text{Do additions } (16 + 3 = 19). \\ &= 18 && \text{Do subtractions } (19 - 1 = 18). \end{aligned}$$

EXAMPLE 3 Simplifying numerical expressionsSimplify $2^3 \div 4 \cdot 2 + 3(5 - 2) - 3 \cdot 2$.**SOLUTION 3**

$$\begin{aligned} 2^3 \div 4 \cdot 2 + 3(5 - 2) - 3 \cdot 2 & && \\ = 2^3 \div 4 \cdot 2 + 3(3) - 3 \cdot 2 &&& \text{Do calculations inside parentheses } (5 - 2 = 3). \\ = 8 \div 4 \cdot 2 + 3(3) - 3 \cdot 2 &&& \text{Do exponents } (2^3 = 8). \\ = 2 \cdot 2 + 3(3) - 3 \cdot 2 &&& \text{Divide 8 by 4.} \\ = 4 + 3(3) - 3 \cdot 2 &&& \text{Multiply 2 by 2.} \\ = 4 + 9 - 3 \cdot 2 &&& \text{Multiply 3 by 3.} \\ = 4 + 9 - 6 &&& \text{Multiply 3 by 2.} \\ = 13 - 6 &&& \text{Add 4 and 9.} \\ = 7 &&& \text{Subtract 6 from 13.} \end{aligned}$$

PROBLEM 3

Simplify.

$$6 \div 3 \cdot 2 + 2(5 - 3) - 2^2 \cdot 1$$

B > More Than One Set of Grouping Symbols

Suppose you wish to buy 2 bedspreads and 2 mattresses. The price of *one* bedspread and *one* mattress is $\$14 + \88 . Thus, the price of *two* of each is $2 \cdot (14 + 88)$. If, in addition, you wish to buy a lamp, the total price is

$$[2 \cdot (14 + 88)] + 12$$

We have used two types of grouping symbols in the expression, parentheses () and brackets []. There is one more grouping symbol, braces { }. When grouping symbols occur within other grouping symbols, computations in the innermost ones are done first. Thus, to simplify $[2 \cdot (14 + 88)] + 12$, we *first* add 14 and 88 (the innermost grouping symbols), then multiply by 2, and finally add the 12. Here is the procedure:

$$\begin{aligned} [2 \cdot (14 + 88)] + 12 &= [2 \cdot (102)] + 12 && \text{Add 14 and 88.} \\ &= 204 + 12 && \text{Multiply 2 by 102.} \\ &= 216 && \text{Add 204 and 12.} \end{aligned}$$

EXAMPLE 4 Simplifying numerical expressionsSimplify $20 \div 4 + \{2 \cdot 3^2 - [3 + (6 - 2)]\}$.**SOLUTION 4**

$$\begin{aligned}
 &20 \div 4 + \{2 \cdot 3^2 - [3 + (6 - 2)]\} \\
 &= 20 \div 4 + \{2 \cdot 3^2 - [3 + 4]\} && \text{Subtract inside parentheses } (6 - 2 = 4). \\
 &= 20 \div 4 + \{2 \cdot 3^2 - 7\} && \text{Add inside brackets } (3 + 4 = 7). \\
 &= 20 \div 4 + \{2 \cdot 9 - 7\} && \text{Do exponents } (3^2 = 9). \\
 &= 20 \div 4 + \{18 - 7\} && \text{Multiply inside braces } (2 \cdot 9 = 18). \\
 &= 20 \div 4 + 11 && \text{Subtract inside braces } (18 - 7 = 11). \\
 &= 5 + 11 && \text{Divide 20 by 4 } (20 \div 4 = 5). \\
 &= 16 && \text{Add } (5 + 11 = 16).
 \end{aligned}$$

PROBLEM 4

Simplify.

$$25 \div 5 + \{3 \cdot 2^2 - [5 + (4 - 1)]\}$$

C > Applications Involving Order of Operations**EXAMPLE 5** Finding the ideal heart rate

When swimming, you expend less energy than when running to get the same benefit. To calculate your ideal heart rate while swimming, subtract your age A from 205, multiply the result by 7, and divide the answer by 10. In symbols,

$$\text{Ideal rate} = [(205 - A) \cdot 7] \div 10$$

Suppose you are 25 years old ($A = 25$). What is your ideal heart rate?**SOLUTION 5**

$$\begin{aligned}
 \text{Ideal rate} &= [(205 - A) \cdot 7] \div 10 \\
 &= [(205 - 25) \cdot 7] \div 10 && \text{Let } A = 25. \\
 &= [180 \cdot 7] \div 10 && \text{Subtract inside the parentheses.} \\
 &= 1260 \div 10 && \text{Multiply inside the brackets.} \\
 &= 126 && \text{Divide.}
 \end{aligned}$$

PROBLEM 5

Find your ideal heart rate while swimming if you are 35 years old.

EXAMPLE 6 Estimating vacation costs

You are ready for your spring break and want to go to the Bahamas with 19 friends; a total of 20 people. A travel agent charges \$50 for setting up the trip and \$400 per person. You have a coupon for \$100 off the total.

- Write an expression for the total cost (using the coupon).
- Evaluate the expression and find the total cost.

SOLUTION 6

- The expression will consist of

$$50 + 20(400) - 100$$

\$50 setup + cost for 20 people - \$100 coupon

- We use the order of operations to simplify the expression.

$$\begin{array}{r r r}
 50 & + & 20(400) & - & 100 \\
 50 & + & 8000 & - & 100 & \text{Multiply.} \\
 8050 & & & - & 100 & \text{Add.} \\
 & & & & 7950 & \text{Subtract.}
 \end{array}$$

Thus, the total cost of the trip is \$7950 after the discount.

PROBLEM 6

You are having a party for 40 of your friends. The rental fee for the recreation hall is \$150, and the caterer charges \$25 per person but will give you a \$100 discount if you pay up front.

- Write an expression for the total cost assuming you pay up front.
- Evaluate the expression and find the total cost.

Answers to PROBLEMS4. 9 5. 119 6. a. $150 + [25(40) - 100]$ b. \$1050

Now that you know how much to pay for your vacation, we are ready to save some money in your electric usage. According to the U.S. Department of Energy the formula for estimating energy consumption is:

$$\text{Wattage} \times \text{Hours used per day} \div 1000 = \text{Daily kilowatt-hour (kWh) consumption}$$

Source: http://www.energysavers.gov/your_home/appliances/index.cfm/mytopic=10040.

If you then want to estimate the **annual** (365-day) power consumption of your PC computer (**120** watts) and your monitor (**150** watts) being used for **4** hours each day, you simply substitute the **120**, **150**, and **4** in the formula, but you have to know about the order of operations to place the numbers correctly.

We show how they do it (incorrectly) in Example 7.

GREEN MATH

EXAMPLE 7 U.S. Department of Energy consumption

$$(120 + 150 \text{ Watts} \times 4 \text{ Hours/day} \times 365 \text{ Days/year}) \div 1000$$

- Is that the correct way to enter the 120 and the 150?
- Find the answer to the nearest kWh.

SOLUTION 7

- To make clear the fact that we want to **add** the number of watts **first**, we should write the formula as

$$(120 + 150) \text{ Watts} \times 4 \text{ Hours/day} \times 365 \text{ Days/year} \div 1000$$

- To find the answer we follow the order of operations: **PEMDAS**

P $(270) \text{ Watts} \times 4 \text{ Hours/day} \times 365 \text{ Days/year} \div 1000$

M by 4 $1080 \text{ Watts} \times 365 \text{ Days/year} \div 1000$

M by 365 $394,200 \text{ Watts} \div 1000$

D by 1000 394.2

To the nearest kWh, we get 394 kWh.

How much would it cost to run the computer and monitor for a year? It depends on the cost of electricity in your area. For a map showing kWh cost by state try <http://michaelbluejay.com/electricity/cost.html>.

PROBLEM 7

The Department of Energy uses the given formula to compute (to the nearest kWh) the annual energy consumption of a 200-watt fan run 4 hours a day for 120 days. What is the answer?

Calculator Corner

Does your calculator know the order of operations? We can give your calculator a test to see if it does! Enter **3** **+** **4** **×** **5** **ENTER**. What answer should the calculator give you? It should be 23 (multiply 4 by 5 first and then add 3). But what if we get 35 for an answer? This means that the calculator performs the operations as they are entered rather than following the order of operations. In this case, the calculator added 3 and 4 and then multiplied the result, 7, by 5. If you have a calculator like this, you have to enter the operations in the order in which you want them performed. Thus, you should enter **4** **×** **5** **+** **3** **ENTER**. Sometimes, you can remedy this problem by using parentheses to indicate which operation you want performed first, that is, you would enter **3** **+** **(** **4** **×** **5** **)** **ENTER** and obtain 23.

Answers to PROBLEMS

7. 96 kWh



> Practice Problems > Self-Tests
> Media-rich eBooks > e-Professors > Videos

> Exercises 1.8

< A > Order of operations In Problems 1–20, simplify.

- | | | |
|--|---|--|
| 1. $4 \cdot 5 + 6$ | 2. $3 \cdot 4 + 6$ | 3. $7 + 3 \cdot 2$ |
| 4. $6 + 9 \cdot 2$ | 5. $7 \cdot 8 - 3$ | 6. $6 \cdot 4 - 9$ |
| 7. $20 - 3 \cdot 5$ | 8. $30 - 6 \cdot 5$ | 9. $48 \div 6 - (3 + 2)$ |
| 10. $81 \div 9 - (4 + 5)$ | 11. $3 \cdot 4 \div 2 + (6 - 2)$ | 12. $3 \cdot 6 \div 2 + (5 - 2)$ |
| 13. $6 \div 3 \cdot 3 \cdot 3 + 4 - 1$ | 14. $10 \div 2 \cdot 2 \cdot 2 + 3 - 2$ | 15. $8 \div 2 \cdot 2 \cdot 2 - 3 + 5$ |
| 16. $9 \div 3 \cdot 3 \cdot 3 - 8 + 5$ | 17. $10 \div 5 \cdot 2 + 8 \cdot (6 - 4) - 3 \cdot 4$ | 18. $15 \div 3 \cdot 3 + 2 \cdot (5 - 2) + 8 \div 4$ |
| 19. $4 \cdot 8 \div 2 - 3(4 - 1) + 9 \div 3$ | 20. $6 \cdot 3 \div 3 - 2(3 - 2) - 8 \div 2$ | |

< B > More than one set of grouping symbols In Problems 21–25, simplify.

- | | |
|---|---|
| 21. $20 \div 5 + [4 + (5 - 3)]$ | 22. $30 \div 6 + [4 \div 2 \cdot 3 + (3 + 5)]$ |
| 23. $(20 - 15) \cdot [20 \div 2 - (2 \cdot 2 + 2)]$ | 24. $(30 - 10) \cdot [52 \div 4 - (3 \cdot 3 + 3)]$ |
| 25. $\{4 \div 2 \cdot 6 - (3 + 2 \cdot 3) + [5(3 + 2) - 1]\}$ | |

< C > Applications Involving Order of Operations

26. *Babysitting pay* You have a babysitting job paying \$5 an hour. You work for 4 hours and they give you a \$10 tip.
- Write an expression for your total earnings.
 - Evaluate the expression to find the total earnings.
27. *Mowing lawns* You are mowing lawns, making \$10 an hour. You mow a lawn in 3 hours, but they must also pay you for \$2 worth of gas and oil.
- Write an expression for your total earnings.
 - Evaluate the expression to find the total earnings.

Is there a difference between fat calories and carbohydrate calories? The answer is yes. Each gram of fat contains 9 calories, but each gram of carbohydrate has only 4. To find the percent of fat in a dish, use this procedure:

- Multiply the number of grams of fat by 9.
- Divide by the total calories and multiply by 100.
- Round to the nearest whole number.

Note that you don't have to know about percents yet, the formula automatically tells you the percent of fat! For example, salmon smothered in cream sauce has 1024 total calories and 76 grams of fat. The percent of fat calories in the salmon is:

- $9 \cdot 76 = 684$
- $684/1024 \cdot 100 = 66.797$
- The nearest whole number is 67.

Thus, 67% of the calories in this dish come from fat.

28. *Fat calories* A quarter-pound cheeseburger, large fries, and a 16-ounce soda from McDonald's have about 1200 calories and 50 grams of fat. What percent of the calories come from fat?
29. *Fat calories* Three slices of cheese pizza and a 16-ounce diet soda from Domino's have about 510 calories and 15 grams of fat. What percent of the calories come from fat?
30. *Fat calories* A taco salad and 16-ounce soda from Taco Bell have about 1045 calories and 55 grams of fat. What percent of the calories come from fat?
31. *Fat calories* One piece of fried chicken (wing), mashed potatoes and gravy, coleslaw, and a 16-ounce diet soda from KFC contain about 380 calories and 19 grams of fat. What percent of the calories come from fat?

Follow the same three steps as for calculating the percent of fat calories in food, but in step 1 multiply by 4 instead of 9.

- 32. Carbohydrate calories** A half-cup serving of vanilla ice cream has about 180 calories and 15 grams of carbohydrates. What percent of the calories come from carbohydrates?
- 33. Carbohydrate calories** On the other hand, one-half cup of cooked carrots has about 36 calories and 8 grams of carbohydrates. What percent of the calories come from carbohydrates?
- 34. Carbohydrate calories** An Arby's Bacon Cheddar Deluxe, regular fries, and a soft drink have about 1000 calories and 100 grams of carbohydrates. What percent of the calories come from carbohydrates?
- 35. Carbohydrate calories** A Burger King Whopper with cheese, regular fries, and a medium drink have about 1380 calories and 150 grams of carbohydrates. What percent of the calories come from carbohydrates?

Did you find any proteins in Problems 28–35? The percent of protein calories in food can be found by following similar steps to those in Problems 28–35. As it turns out, a gram of protein contains the **same** amount of calories as one gram of carbohydrates: **4 calories**.

Calculating the percent of protein calories in food Follow the same three steps as for calculating the percent of carbohydrate calories in food to find the *percent* of protein calories in:

- 36. Protein calories** A McDonald's hamburger (105 grams) with 280 calories and 12 grams of protein.
- 37. Protein calories** A Carl's Jr. Hamburger (119 grams) with 284 calories and 14 grams of protein.
- 38. Protein calories** A Sonic Jr. Burger (135 grams) with 353 calories and 14 grams of protein.
- 39. Protein calories** A McDonald's McChicken (147 grams) with 430 calories and 14 grams of protein.
- 40. Protein calories** A Jack in the Box Chicken Sandwich (145 grams) with 390 calories and 15 grams of protein.
Source: <http://www.foodfacts.info/>.

Estimating the weight of a child The weight of a child (in kilograms) can be estimated based on age using the proper formula but you have to know the order of operations and the meaning of grouping symbols to do it correctly! In the table below, the asterisk * is used to indicate multiplication and the / is used to indicate division.

Age	Weight in Kilograms
At birth	3.25
From 3 to 12 months	$[(\text{Age in months}) + 9] / 2$
From age 1 to 6 years	$[(\text{Age in years}) * 2] + 8$
From age 7 to 12 years	$\{[(\text{Age in years}) * 7] - 5\} / 2$

Source: medal.org.

- 41.** Estimate the weight of a child at birth.
- 42.** Estimate the weight of a child 11 months old.
- 43.** Estimate the weight of a child 5 years old.
- 44.** Estimate the weight of a child 9 years old.
- 45.** To find the weight of a 6 year old child, we should use the formula
- $$[(\text{Age in years}) * 2] + 8$$
- a.** Find the weight of the child using this formula.
- b.** Suppose you use the formula $\{[(\text{Age in years}) * 7] - 5\} / 2$ which applies to 7- to 12-year-olds instead. To the nearest kg, what weight do you get then?
- 46.** There is an age in which the formulas $[(\text{Age in years}) * 2] + 8$ and $\{[(\text{Age in years}) * 7] - 5\} / 2$ give the same result. Substitute 1, 2, 3, 4, 5, 6, and 7 for the age in each of the formulas and discover at what age the results coincide.

Using Your Knowledge

What is the corresponding dose (amount) of medication for children when the adult dosage is known? There are several formulas that tell us.

- 47. Fried's rule** (for children under 2 years):

$$(\text{Age in months} \cdot \text{adult dose}) \div 150 = \text{child's dose}$$

Suppose a child is 10 months old and the adult dose is a 75-milligram tablet. What is the child's dose? [Hint: Simplify $(10 \cdot 75) \div 150$.]

- 49. Young's rule** (for children between 3 and 12):

$$(\text{Age} \cdot \text{adult dose}) \div (\text{age} + 12) = \text{child's dose}$$

Suppose a child is 6 years old and the adult dose of an antibiotic is 3 tablets every 12 hours. What is the child's dose? [Hint: Simplify $(6 \cdot 3) \div (6 + 12)$.]

- 48. Clarke's rule** (for children over 2 years):

$$(\text{Weight of child} \cdot \text{adult dose}) \div 150 = \text{child's dose}$$

If a 7-year-old child weighs 75 pounds and the adult dose is 4 tablets a day, what is the child's dose? [Hint: Simplify $(75 \cdot 4) \div 150$.]

You already know how to use the order of operations to evaluate expressions. Here is a more challenging game: Use the numbers 1, 2, 5, and 6, any of the operations we have studied, and parentheses to make an expression whose value is 24. Here is one: $(1 + 5) \cdot (6 - 2)$.

Now, you make your own expression using the given numbers.

50. 1, 2, 7, 2

51. 2, 3, 3, 8

52. 4, 6, 9, 5

53. 2, 3, 8, 9

>>> Write On

54. A student claimed that the answer to $15 + 5 \times 10$ is 200. What did the student do wrong?
55. The order of operations is PEMDAS, which lists multiplication before division. Using multiplication before division, what would be the value of $4/2 \cdot 2 + 3$?
The order of operations also states that the operations must be performed from left to right. Evaluate $4/2 \cdot 2 + 3$ if we do the operations as they occur from left to right.
56. In Problem 55, which answer is correct, 4 or 7? How can we make the rule more precise?

>>> Concept Checker

Fill in the blank(s) with the correct word(s), phrase, or mathematical statement.

We can remember the order of operations when evaluating an expression by remembering **PEMDAS**.

- | | | |
|--|--------------------|-----------------------|
| 57. P means to do the calculations inside the grouping symbols such as _____. | exponential | multiplication |
| 58. E means to evaluate all _____ expressions. | division | parentheses |
| 59. M means to do all _____ in order from left to right. | addition | powers |
| 60. D means to do all _____ in order from left to right. | subtraction | |
| 61. A means to do all _____ in order from left to right. | | |
| 62. S means to do all _____ in order from left to right. | | |

>>> Mastery Test

63. Simplify: $2^3 \div 8 \cdot 2 + 4(6 - 1) - 2 \cdot 3$
64. Simplify: $15 \div 3 + \{3 \cdot 2^2 - [4 + (5 - 3)]\}$
65. Simplify: $81 \div 9 - (3 + 4)$
66. A travel agent charges \$50 for setting up a cruise for 10 people, plus \$500 per person. If you get a \$100 discount:
a. Write an expression for the total cost.
b. Evaluate the expression and find the total cost.
67. Simplify: $27 \div 3 \cdot 3 \cdot 3 + 4 - 1$
68. Simplify: $7 \cdot 3^2 - 5$
69. Simplify: $2^3 + 4 \cdot 5$

>>> Skill Checker

70. Find the product $3^4 \cdot 2^2$.
71. Find the product $2^4 \cdot 3^2$.
72. Write the product $3^2 \cdot 10^2$ in words.
73. Write the product $2^3 \cdot 3^2 \cdot 10^2$ in words.
74. Write $3^0 \cdot 10^2 \cdot 2^2$ in expanded form.

1.9

Equations and Problem Solving

▶ Objectives

You should be able to:

A > Solve equations by using number facts.

B > Solve equations using the addition, subtraction, or division principle given in the text.

C > Solve applications using the concepts studied.

▶ To Succeed, Review How To . . .

1. Use the arithmetic facts (+, −, ×, ÷). (pp. 24, 38, 51, 63)
2. Check subtraction using addition. (p. 38)
3. Write a division problem as an equivalent multiplication problem. (p. 63)

▶ Getting Started

The ad says that you can save \$30 when you buy an electric cooktop. If the cooktop costs \$280 now, how much did it cost before? Since it costs \$280 now and you are saving \$30, it used to cost \$30 *more*, that is, $\$280 + 30 = \310 . If you think of the old cost as c , you can write the problem like this:

The new cost is the old cost reduced by \$30:

$$\$280 = c - \$30$$

With what number can you replace c to make the statement true? The answer is again \$310.



Electric cooktop **Cut \$30**

A > Solving Equations

Sentences such as $280 = c - 30$ or $27 = 7 + x$ that contain the equals sign (=) are called **equations**.

SOLUTIONS

The **solution** of an equation is the replacement that makes the equation a *true* statement. When we find the solution of an equation we say that we have **solved the equation**.

Thus, the *solution* of $280 = c - 30$ is **310**
 because $280 = 310 - 30$
 Similarly, the solution of $27 = 7 + x$ is **20**
 because $27 = 7 + 20$

EXAMPLE 1 Finding solutions to equations by substitution

Find the solution of each equation.

- a. $x + 7 = 13$ b. $10 - x = 3$
 c. $15 = 5x$ d. $24 \div x = 6$

SOLUTION 1

- a. We have to find a number x so that when we add 7 to it, we get 13. You can do this mentally or by substitution.

If we replace x with 5, we get $5 + 7 = 13$. False!If we replace x with 6, we get $6 + 7 = 13$. True.Thus, the solution of $x + 7 = 13$ is $x = 6$.*

- b. We need to find a number x so that when we subtract it from 10, the answer is 3. You can do this mentally or by substitution.

If we replace x with 5, we get $10 - 5 = 3$. False!Since $10 - 5 = 5$, we need a larger number for x .If we replace x with 6, we get $10 - 6 = 3$. False!

We need a bigger number. Try 7.

If we replace x with 7, we get $10 - 7 = 3$. True.Thus, the solution of $10 - x = 3$ is $x = 7$.

- c. To solve $15 = 5x$, we need a number that multiplied by 5 would give us 15. You can do this mentally. The number is 3. Thus, the solution of $15 = 5x$ is $x = 3$.
- d. Here we need a number x so 24 divided by this number would yield 6. You can do this mentally or by substitution. We can try 3. But $24 \div 3 = 8$ (not 6). If we try 4, we get $24 \div 4 = 6$, which is the desired result. The solution is $x = 4$.

PROBLEM 1

Find the solution of each equation.

- a. $x + 6 = 15$ b. $13 - x = 4$
 c. $24 = 8x$ d. $36 \div x = 9$

B > Rules for Solving Equations

So far, we have solved our equations by trial and error. We need some rules to follow. These rules are based on the idea of equivalent equations, equations that have the same solution.

EQUIVALENCE

Two equations are **equivalent** if their solutions are the same.

For example, $x + 7 = 10$ is equivalent to $x = 3$, but $x = 3$ has an obvious solution. Let us go back to the equation at the beginning of this section.

$$\begin{array}{ccccccc} \text{The new cost is the old cost reduced by } \$30 & & & & & & \\ \downarrow & \downarrow & & \downarrow & & \downarrow & \\ \$280 & = & c & - & \$30 & & \end{array}$$

Answers to PROBLEMS

1. a. $x = 9$ b. $x = 9$
 c. $x = 3$ d. $x = 4$

* Technically, the solution is 6, but some people write $x = 6$ instead.

To find the cost c we restore the \$30 cut; that is,

$$\$280 + 30 = c - 30 + 30$$

or

$$310 = c$$

This example illustrates the fact that we can *add* the same number on both sides of the equation and produce an *equivalent* equation. Here is the idea:

ADDITION PRINCIPLE (PROPERTY)

The equation $a = b$ is equivalent to $a + c = b + c$

Note: Some books use the word “property” instead of “principle.”

Thus, we can add the same number c to both sides of an equation and obtain an equivalent equation.

EXAMPLE 2 Using the addition principle

Solve.

a. $n - 17 = 20$

b. $30 = m - 18$

SOLUTION 2

a. The idea is to have n by itself on one side of the equation. Thus, we want to “restore” the 17. We do this by adding 17 to both sides.

We get:

$$\begin{aligned} n - 17 &= 20 \\ n - 17 + 17 &= 20 + 17 && \text{Add 17 on both sides.} \\ n &= 20 + 17 && n + 0 = n \\ n &= 37 && \text{Add.} \end{aligned}$$

The solution is $n = 37$. (Check: Substitute 37 in the original equation to get $37 - 17 = 20$, a true statement.)

b. This time we add 18 to both sides, obtaining

$$\begin{aligned} 30 + 18 &= m - 18 + 18 && \text{Add 18.} \\ 48 &= m && m + 0 = m \end{aligned}$$

The solution is $48 = m$. (Check: $30 = 48 - 18$.)

PROBLEM 2

Solve.

a. $n - 13 = 17$ b. $20 = m - 3$

Now, suppose the cost of the cooktop has gone *up* \$30 and the new cost is \$280. What was the old cost c ? The equation here is

$$\begin{array}{ccccc} & & c + 30 = 280 & & \\ & \nearrow & & \nwarrow & \\ \text{Old cost} & & \text{up } \$30 & & \text{new cost} \end{array}$$

This time, we bring the price *down* by *subtracting* \$30 from both sides of the equation. We get

$$\begin{aligned} c + 30 &= 280 \\ c + 30 - 30 &= 280 - 30 \\ c &= 250 \end{aligned}$$

Thus, the old cost was \$250. We have used the following principle.

SUBTRACTION PRINCIPLE (PROPERTY)

The equation $a = b$ is equivalent to $a - c = b - c$

Answers to PROBLEMS

2. a. $n = 30$ b. $m = 23$

EXAMPLE 3 Using the subtraction principle

Solve.

a. $n + 15 = 48$

b. $43 = 18 + m$

SOLUTION 3

a.

$$\begin{array}{r} n + 15 = 48 \\ n + 15 - 15 = 48 - 15 \quad \text{Subtract 15 from both sides.} \\ n = 48 - 15 \\ n = 33 \quad 48 - 15 = 33 \end{array}$$

The solution is $n = 33$. (You can check this in the original equation, since $33 + 15 = 48$.)

b.

$$\begin{array}{r} 43 = 18 + m \\ 43 - 18 = 18 + m - 18 \quad \text{Subtract 18 from both sides.} \\ 43 - 18 = m \quad 18 + m - 18 = m \\ 25 = m \quad 43 - 18 = 25 \end{array}$$

The solution is $m = 25$. (Check: $43 = 18 + 25$.)

PROBLEM 3

Solve.

a. $n + 10 = 13$

b. $39 = 18 + m$

Now, suppose the cost of the cooktop has *doubled*; it now costs \$280. What was the old cost c ? Since the old cost c has doubled and it is now \$280, the equation is $2c = 280$. To find the answer, we must cut the cost in *half* by dividing by 2. Thus, the old cost c was \$140. This example suggests that we can *divide* both sides of an equation by a (*nonzero*) number and obtain an equivalent equation. Here is the principle.

DIVISION PRINCIPLE (PROPERTY)

The equation $a = b$ is equivalent to $a \div c = b \div c$ ($c \neq 0$)

EXAMPLE 4 Using the division principle

Solve.

a. $3x = 33$

b. $48 = 6x$

SOLUTION 4

a. We use the division principle and divide on both sides by **3**, obtaining:

$$\begin{array}{r} 3x = 33 \\ 3x \div 3 = 33 \div 3 \quad \text{Divide both sides by 3.} \\ x = 33 \div 3 \quad \text{Divide 3x by 3.} \\ x = 11 \quad \text{Divide 33 by 3.} \end{array}$$

b. We divide both sides by **6**, obtaining:

$$\begin{array}{r} 48 = 6x \\ 48 \div 6 = 6x \div 6 \quad \text{Divide both sides by 6.} \\ 48 \div 6 = x \quad \text{Divide 6x by 6.} \\ 8 = x \quad \text{Divide 48 by 6.} \end{array}$$

PROBLEM 4

Solve.

a. $4x = 36$

b. $42 = 7x$

Answers to PROBLEMS

3. a. $n = 3$ b. $m = 21$

4. a. $x = 9$ b. $x = 6$

C > Applications: The RSTUV Method

Now that you've learned how to solve equations, you need to know how to apply this knowledge to solve real-world problems. These problems are usually stated in words and consequently are called **word** or **story** problems. This is an area in which many students encounter difficulties, but don't panic; we are about to give you a sure-fire method of tackling word problems. To start, let us look at this problem.

The Sears Tower (now called the Willis Tower) is 1454 feet tall. The addition of two antennas brought the height to 1559 feet. How tall are the antennas?

Before we attempt to solve this problem, we shall discuss an effective way to solve such a problem. The procedure is as easy as 1-2-3-4-5.

RSTUV PROCEDURE TO SOLVE WORD PROBLEMS

1. Read the problem carefully and decide what is asked for (the unknown).
2. Select \square or a letter to represent the unknown.
3. Translate the problem into an equation.
4. Use the rules we have studied to solve the equation.
5. Verify the answer.

This is the method you really want to learn to master word problems.

How do we remember all of these steps? Easy. Look at the first letter in each sentence (in bold). Do you see now why we call this the RSTUV method? To help you even more, here are some hints and tips for using the method.

1. **Read the problem.** Mathematics is a language. You have to learn how to read it. You may not understand or even get through reading the problem the first time. That's OK. Read it again, and as you do, pay attention to key words or instructions such as *compute*, *draw*, *write*, *construct*, *make*, *show*, *identify*, *state*, *simplify*, *solve*, and *graph*. (Can you think of others?)
2. **Select the unknown.** How can you answer a question if you don't know what the question is? One good way to look for the unknown (variable) is to look for the question mark and read the material to its left. Try to determine what is given and what is missing. Remember, this is your word problem, so you can use any letter you wish for the unknown. Here is a suggestion: Use h for height, s for speed, p for population, d for distance, and so on.
3. **Translate the problem into an equation or inequality.** Problem solving requires many skills and strategies. Some of them are *look for a pattern*; *examine a related problem*; *use a formula*; *make tables, pictures, or diagrams*; *write an equation*; *work backward*; and *make a guess*. When you solve problems, your plan should lead to writing an equation or an inequality.
4. **Use the rules we have studied to solve the equation.** If you are studying a mathematical technique, it's almost certain that you will have to use it in solving the given problem. Look for ways the technique you're studying (addition, subtraction, and division principles, for example) could be used to solve the problem.
5. **Verify the answer.** Look back and check the results of the original problem. Is the answer reasonable? Can you find it some other way?

Now, let us use the RSTUV procedure to solve Example 5.

EXAMPLE 5 Problem solving: RSTUV method

The Willis Tower, in Chicago, is 1454 feet tall. The addition of two antennas brought the height to 1559 feet. How tall are the antennas?

SOLUTION 5

1. Read the problem. Read the problem slowly, not once but two or three times. (Reading mathematics is not like reading a magazine; mathematics problems may have to be read several times before you understand them. It is OK, as long as you do understand them.)

2. Select the unknown. The problem asks for the height of the antennas. What would you call this height? We will use h for height. h is what we are looking for and is our unknown.

3. Translate the problem into an equation or inequality. The problem says that the Willis Tower is 1454 feet high. The *addition* of two antennas brought the height to 1559 feet. Here is the translation:

Willis Tower height + Two antennas height reached 1559

$$1454 + h = 1559$$

4. Use the rules we have studied to solve the equation. To solve this equation, we use the subtraction principle and subtract 1454 from both sides of the equation (so that we can have h by itself on the left side).

$$1454 - 1454 + h = 1559 - 1454$$

Simplify $h = 105$

Thus, the height h of the antennas is 105 feet.

5. Verify the answer. To verify the answer, recall that: The addition of the antennas (105) brought the height to 1559. Is it true that the original height (1454) plus 105 is 1559? Yes, $1454 + 105 = 1559$, so our answer is correct! Congratulations, you solved your first word problem using the RSTUV method! Now, use the same procedure and do Problem 5.

PROBLEM 5

Suppose the Willis Tower is 1559 feet tall. The addition of an antenna brought the height to 1710 feet. How tall is the antenna?

EXAMPLE 6 Problem solving: tuition and fees

In a recent year the charges for tuition and fees T plus room and board R , for 1 year, at a public 4-year college amounted to \$12,127. The room and board R cost \$1145 more than the tuition and fees T . What are the costs of tuition and fees T and the costs of room and board R ?

SOLUTION 6

1. Read the problem. This time there are **two** unknowns.

2. Select the unknowns. The two unknowns are: tuition and fees T and room and board R .

3. Translate the problem into an equation or inequality. There are two sentences to translate:

“tuition and fees T plus room and board R amounted to \$12,127”

This means that: (1) $T + R = \$12,127$

“The room and board R cost \$1145 more than tuition and fees T ”

This means that: (2) $R = T + \$1145$

Since we need one unknown only, substitute $T + 1145$ for R in (1)

Like this: (1) $T + R = \$12,127$

Substituting $T + (T + \$1145) = \$12,127$

PROBLEM 6

College charges for tuition and fees T plus room and board R , for 1 year, at a private 4-year college amounted to \$29,026. The tuition and fees T cost \$13,444 more than the room and board R . Use the RSTUV procedure to find the cost of tuition and fees T and the cost of room and board R .

Answers to PROBLEMS

5. 151 feet 6. $R = \$7791$, $T = \$21,235$

4. Use the rules we have studied to solve the equation.

To solve $T + (T + \$1145) = \$12,127$

Add like terms ($T + T = 2T$) $2T + \$1145 = \$12,127$

Subtract **\$1145** to isolate T $2T + \$1145 - \mathbf{\$1145} = \$12,127 - \mathbf{\$1145}$
 $2T = \$10,982$

Divide both sides by 2 $T = \$5491$

This means: (2) $R = \$5491 + \$1145 = \$6636$

5. Verify the answer. Is it true that tuition and fees (**\$5491**) plus room and board (**\$6636**) amount to \$12,127? Yes, $\$5491 + \$6636 = \$12,127$. Our answer is correct!

Source: <http://www.ed.gov/about/bdscomm/list/hiedfuture/2ndmeeting/trends.pdf>.

GREEN MATH

EXAMPLE 7 Keeping your cool and saving energy

If you use an air conditioner that uses A watts of power and an attic fan using F watts of power, you are using a total of 1300 watts. The air conditioner A uses 500 more watts than the attic fan F . How many watts does each of the items use?

SOLUTION 7

1. Read the problem. There are **two** unknowns.

2. Select the unknowns. The two unknowns are: A the watts for the air conditioner and F the watts for the fan.

3. Translate the problem into an equation or inequality. There are two sentences to translate:

“The air conditioner uses A watts and the fan uses F watts for a total of 1300”

This means that: (1) $A + F = 1300$

“The air conditioner A uses 500 more watts than the fan F ”

This means that: (2) $A = F + 500$

Since we need one unknown only, substitute $F + 500$ for A in (1)

Like this: (1) $A + F = 1300$

Substituting $(F + 500) + F = 1300$

4. Use the rules we have studied to solve the equation.

To solve $(F + 500) + F = 1300$

Add like terms ($F + F = 2F$) $2F + 500 = 1300$

Subtract **500** to isolate $2F$ $2F + 500 - \mathbf{500} = 1300 - \mathbf{500}$
 $2F = 800$

Divide both sides by 2 $F = 400$

This means: (2) $A = F + 500$ becomes $A = 400 + 500 = 900$

5. Verify the answer. Is it true that the air conditioner uses 500 more watts than the fan? Yes, the air conditioner uses 900 watts and the fan uses 400.

Our answer is correct!

PROBLEM 7

Together, your computer and monitor use 270 watts of power. If the monitor uses 30 more watts than the computer, how many watts does each use? By the way, if the computer and the monitor are in sleep mode, you will only use about 60 watts.

Answers to PROBLEMS

7. Computer 120, monitor 150

TRANSLATE THIS

1. Of the 995 candy products introduced in a recent year, 398 were chocolate. Write an equation for N , the number of candies that were *not* chocolate.

Source: National Confectioners Assoc.

2. Who spends the most on women's clothes? According to MapInfo, Connecticut women (C) do. As a matter of fact, they spend \$27 dollars more per household annually than women (N) in New Jersey. Write an equation for C .
3. If you are under 25 years old, your probability P of completing college is 69 percent, an increase of 12% over the probability 10 years ago.
4. You can buy a computer with a \$100 discount. If the original price of the computer was P , what is the discounted price D ?
5. Do women want to be thin or smarter? In a recent survey conducted by eDiets.com the percent of women T who wanted to be thinner exceeded the percent of women S who wanted to be smarter by 12%. Write an equation for T .
6. When jogging you will burn 675 calories each hour. What is the number of calories C burned in h hours of jogging?

The third step in the RSTUV procedure is to **TRANSLATE the information into an equation. In Problems 1–10 TRANSLATE the sentence and match the correct translation with one of the equations A–O.**

- A. $995 = N - 398$
 B. $69 = P + 12$
 C. $T = S + 12$
 D. $C = \frac{24W}{2.2} + \frac{0.70 \cdot 24W}{2.2}$
 E. $S = T + 12$
 F. $D = P - 100$
 G. $\text{BMR} = 2W + W$
 H. $\text{BMI} = \frac{P}{705H^2}$
 I. $995 - 398 = N$
 J. $\text{BMR} = \frac{705P}{H^2}$
 K. $C = 675h$
 L. $\$100 = D - P$
 M. $\text{BMR} = 10W + W$
 N. $C = N + 27$
 O. $\text{BMR} = 10W + 2W$

7. How many calories C do you need in a 24-hour day? It depends on your weight W in pounds and your daily activities.

Here are the steps:

1. Divide W by 2.2.
 2. Multiply by 24.
- These are the calories you need for basic function.
3. If your daily activities are moderate, multiply the result in 2 by 0.70.
 4. Add the results of steps 2 and 3. This is C .
8. The basal metabolic rate (BMR) for an adult male is obtained by multiplying his body weight W by 10 and adding double his body weight to this value. What is the formula for the BMR of an adult male?
9. The BMR for an adult female is obtained by multiplying her body weight W by 10 and adding her body weight to this value. What is the formula for the BMR of an adult female?
10. The body mass index (BMI) is a reliable indicator of body fatness for most people. BMI is obtained by multiplying your weight P by 705 and dividing by the square of your height H .

Note: If your BMI is between 18.5 and 24.9 you are normal!

Exercises 1.9

> Practice Problems > Self-Tests
 > Media-rich eBooks > e-Professors > Videos

< A > Solving Equations In Problems 1–12, find the solution of the equation, mentally or by substitution.

- | | | |
|---------------------|---------------------|---------------------|
| 1. $m + 9 = 17$ | 2. $n + 18 = 29$ | 3. $13 - x = 9$ |
| 4. $19 - x = 8$ | 5. $20 = 4x$ | 6. $27 = 3x$ |
| 7. $9x = 54$ | 8. $8x = 88$ | 9. $30 \div y = 6$ |
| 10. $45 \div y = 5$ | 11. $9 = 63 \div t$ | 12. $7 = 35 \div t$ |

< B > Rules for Solving Equations In Problems 13–24, solve.

- | | | |
|-------------------|-------------------|-------------------|
| 13. $z - 18 = 30$ | 14. $z - 13 = 41$ | 15. $40 = p - 12$ |
| 16. $30 = p - 9$ | 17. $x + 17 = 31$ | 18. $x + 12 = 37$ |
| 19. $30 = 17 + m$ | 20. $21 = 18 + m$ | 21. $4x = 28$ |
| 22. $7x = 49$ | 23. $9x = 36$ | 24. $11x = 121$ |

< C > Applications Using The RSTUV Method In Problems 25–50, use the RSTUV procedure to solve the problem.

- 25. Finding the speed of Thrust 2** The fastest car is the jet-engined Thrust SSC, which can travel 763 miles per hour. This is 130 miles per hour more than the Thrust 2. If s is the speed of the Thrust 2, find s .
- 27. Human-powered flight record** Glenn Tremml holds the record for human-powered flight. The previous record was held by Bryan Allen, who flew 22 miles across the English channel. If d is the distance flown by Glenn, and Bryan flew 15 miles less than that, find d .
- 29. Weight of a brontosaurus** A brontosaurus, a prehistoric animal, weighed about 60,000 pounds. This is four times as much as an average African elephant. If w is the weight of an African elephant, find w .
- 31. Calories in Coke** A McDonald's Quarter Pounder has 420 calories. If you have a small Coca-Cola with that, the total number of calories reaches 570. How many calories are in the Coke?
- 33. Coke calories** A Whopper sandwich contains 640 calories. If you have a medium Coca-Cola Classic with that, the total number of calories reaches 920. How many calories are in the Coke?
- 35. Individual calories** A McDonald's cheeseburger and small fries contain 540 calories. The cheeseburger has 120 more calories than the fries. How many calories are in each food item?
- 37. Tuition cost** At 2-year colleges, books and supplies cost about \$700. If you add to that tuition costs, the total is \$2272. What is the cost of tuition?
Source: Data from The Chronicle of Higher Education.
- 39. Scholarship and grants awards** The combined average financial aid award for scholarship and grants is about \$3600. If the scholarship money is \$400 less than the grant money, what are the average awards for scholarships and for grants?
Source: Data from Office of Student Financial Services.
- 41. Banking** Tran deposited his \$1000 summer earnings at a bank. He also had 5 direct deposit checks for p dollars each deposited in the account.
Write an expression for his balance.
His bank statement indicated a \$2115 balance. What was the amount p of each of the direct deposit checks?
- 43. Banking** Tran wrote four checks for \$50, \$120, \$70, and \$65. If his new balance n was \$907, what was his old (starting) balance?
- 26. Population predictions** It is predicted that by the year 2010 the world population will be 6823 million, 743 million more than in the year 2000. If p was the world population in the year 2000, find p .
- 28. Calories needed for weight maintenance** The number of calories you must eat to maintain your weight w (in pounds) is given by the formula:
$$15w = \text{number of calories}$$

A man is eating 2700 calories a day and maintaining his weight. What is his weight?
- 30. English Smiths** There are three times as many persons named Smith in the United States as there are in England. If the United States has 2,400,000 people named Smith, how many people named Smith are there in England?
- 32. Sodium in Coke** A Quarter Pounder contains 580 mg (milligrams) of sodium. If you have a small Coca-Cola with that, the total number of milligrams of sodium reaches 620. How many milligrams of sodium are in the Coke?
- 34. Coke sodium** A Whopper sandwich contains 870 mg (milligrams) of sodium. If you have a Coca-Cola Classic with that, the total number of milligrams of sodium reaches 920. How many milligrams of sodium are in the Coke?
- 36. Individual calories** A Whopper sandwich and medium fries contain 940 calories. The Whopper has 340 more calories than the fries. How many calories are in each food item?
Source: Olen Publishing.
- 38. Tuition, board, and book costs** If you are a student in a private four-year college, you should expect to pay about \$16,080 a year for tuition and board plus books. If the amount for tuition and board is \$14,680 more than the books, what is the cost of tuition and board and what is the cost of books?
Source: Data from The Chronicle of Higher Education.
- 40. Loans and grants awards** The combined average financial aid award for loans and grants is about \$5350. If the grant money is \$1150 less than the loan money, what are the average awards for loans and for grants?
Source: Data from Office of Student Financial Services.
- 42. Banking** Tran had his monthly car payment of c dollars each deducted from his account. After three monthly payments, his \$2115 balance was down to \$1212. How much was his monthly car payment c ?
- 44. Transportation** Andrea needed some transportation to go to school. She decided to buy a PT Cruiser and pay for it in 5 years (60 monthly payments) at 0% interest. If her total payments amounted to \$24,000, how much was her monthly payment?

- 45. Transportation** Andrea also needed some insurance for her Cruiser. Allstate told her that they would sell her a policy with the coverage she wanted and she could pay in three installments of t dollars each. If the price of the policy was \$1350, what was the amount t of each installment?
- 46. Transportation** Andrea was told that the Cruiser would get about 22 miles per gallon (mpg). She wanted to travel from Tampa to Miami, a distance of about 264 miles. How many gallons of gas would Andrea need?
- 47. Transportation** Andrea is driving from Tampa to Miami and will pass through Yeehaw Junction on the way. If the distance from Tampa to Yeehaw Junction is 106 miles and from Tampa to Miami is 264 miles, how many miles is it from Yeehaw Junction to Miami?
- 48. Transportation** A Mapquest map told Andrea the 264-mile trip would take about 4 hours. What was Andrea's average speed? (*Hint: Distance = Average speed \times Time.*)
- 50. Nutrition** You can burn calories by exercising. Here are the calories burned in one minute of the listed activity.

Type of Exercise	Calories Burned in One Minute
Walking (5 mi/hr)	3
Cycling (12 mi/hr)	10
Weightlifting	12

In Problems 51 and 52, follow the procedure of Example 6 and solve.

- 51. Tips** The tip T plus the cost M of a meal at a restaurant amounted to \$96. If the cost M of the meal was \$64 more than the tip T , how much was the tip and how much was the meal?
- 52. Tuition and fees** The tuition and fees T for courses at a college, for one semester, was \$290 more than the cost B of the books. If the total bill (tuition and fees plus books) came to \$1150, how much was the tuition and fees and how much were the books?



- 49. Nutrition** Did you know that you must burn about 3500 calories to lose one pound of body fat?
- How many calories does it take to lose 15 pounds?
 - Suppose you need 1800 calories to maintain your daily weight and you cut your daily calories to 1300. What is the number of excess calories burned each day?
 - How many days would it take you to lose 15 pounds?
- To burn 3500 calories (the equivalent of one pound loss), how long do you have to (answer to the nearest minute):
- Walk at 5 mi/hr?
 - Ride your bicycle at 12 mi/hr?
 - Lift weights?

>>> Applications: Green Math

What do you do with your e-waste, that is, your television sets, computer products (CPUs, monitors, notebooks, printers, keyboards, and faxes), and cell phones? Here are some problems dealing with electronic waste.

Source: <http://electronicstakeback.com/>.

- 53. Trashing TVs and computers** The number of trashed TVs and computer products in the United States amount to 178 million units each year, but there are 136 million more TVs than computer units trashed. How many TVs and how many computer units are trashed each year in the United States?
- 54. Recycling TVs and computer units** Fortunately, 54 million units of these items are recycled but, as expected, 42 million units more TVs than computer units are recycled. How many TVs and how many computer products are recycled each year?
- 55. Trashing cell phones and computer products** 283 million cell phones and computer products are trashed each year in the United States. If 31 million more units of computer products than cell phones are trashed, how many cell phones and how many computer products are trashed each year?
- 56. Recycling cell phones and computer products** Fortunately 62 million computer products and cell phones are recycled each year; 34 million more computer products than cell phones. How many computer products and how many cell phones are recycled each year?

- 57. Storing at home** As you probably know, we don't trash or recycle most items but stockpile them at home! There are 108 million computers and monitors stored at home and somehow there are 24 million more computers than monitors. How many computers and how many monitors are stored at home?

Be green and save

Source: <http://www.greenandsave.com/>.

- 58. Water savings** If you install new shower heads and water filters in your home you can save \$404 each year, but you save more by installing new shower heads, \$196 more. How much do you save annually with each improvement?
- 59. Winter savings** You can save money in the winter by having a heating system tune-up and sealing your duct leaks for \$480. The duct leak job is \$120 more than the tune-up. What is the cost of each?
- 60. Let the sun shine in** You can save \$1480 in utilities by installing a solar hot water heater and some solar electric panels, which is much more expensive at \$15,500. The solar panels will cost you \$10,500 more than the solar water heater. What is the cost of each item?
- 61. Geothermal and cross ventilation** If you want to go all out, you can install a **geothermal** system for heating and cooling your home and work with your architect or builder so that the windows provide good **cross ventilation** throughout the house. How much will it cost for both? \$31,200! Of course, the geothermal system will cost you \$28,800 more than the cross ventilation. What is the cost of each system?
- 62. Savings with geothermal and cross ventilation** How much can you save if you install your geothermal and cross ventilation system? \$3120, with the geothermal providing \$2880 more in savings. How much do you save with each system?

Using Your Knowledge

- 63.** The formula for the distance d at which a car travels in time t hours at 50 miles an hour is
- $$d = 50t$$
- How long would it take for the car to travel 300 miles?
- 64.** The formula for the velocity V (in feet per second) that an object travels after falling for t seconds is given by
- $$V = 32t$$
- How long would it take an object to reach a velocity of 96 feet per second?

Write On

- 65.** We have an addition, a subtraction, and a division principle. Write in your own words the reasons why we have no multiplication principle.
- 66.** Write in your own words what the multiplication principle should be.
- 67.** The solution of an equation is the replacement that makes the equation a true statement. What is the solution of $x + 1 = 2$? Does your answer satisfy the definition of a solution?
- 68.** What is the solution of $5 + x = 5$? What about the solution of $5 + x = 5 + x$?

Concept Checker

Fill in the blank(s) with the correct word(s), phrase, or mathematical statement.

- 69.** The _____ of an equation is the **replacement** that makes the equation a true statement.
- 70.** If the solutions of two different equations are the **same**, the equations are _____.
- 71.** Using the _____ Principle, the equation $a = b$ is **equivalent** to $a + c = b + c$.
- 72.** The equation $a = b$ is equivalent to the equation _____ using the Subtraction Principle.
- 73.** By the **Division Principle**, the equation $a = b$ is **equivalent** to the equation _____.
- 74.** In the **RSTUV** procedure, the **T** stands for _____.

$a - c = b - c$	equivalent
Addition	solution
$a \div c = b \div c; c \neq 0$	same
translate	equal

>>> Mastery Test

Solve:

75. $x + 8 = 17$

76. $12 - y = 7$

77. $20 = 4x$

78. $28 \div x = 7$

79. $40 = 38 + m$

80. $49 = 7p$

81. $x - 5 = 10$

82. $10 = n - 19$

83. $20 = x + 5$

84. The CN Tower in Canada is said to be 362 feet taller than the Willis Tower, which is 1454 feet high. What is the height of the CN Tower?

Note: Many people do not recognize the CN Tower as a building because, so they say, the CN Tower is not a building. Most of the structure is no more than a concrete shaft housing elevators, and therefore it is not a building, one could argue.

>>> Skill Checker

85. Use long division to divide $\frac{47}{5}$.

86. $0 \div 9 = \underline{\hspace{2cm}}$

> Collaborative Learning

This section will involve three groups of students: Carpenters, Gardeners, and Painters. At least one of the students in each group should have access to a telephone directory or the Internet and be willing to make some phone calls or get information.

Here are the dimensions of the rooms we will work with:

		Area
Family Room:	13' 0" × 15' 0"	
Living Room:	14' 0" × 15' 0"	
Dining Room:	10' 0" × 14' 0"	

Carpenters

In charge of estimating the cost of carpet for the three rooms: family room, living room, and dining room.

- Find the area of each room.
- Find the total area for the three rooms.
- Find the cost of a square foot of carpeting (you may have to call several carpet places or find the prices online).
- Find the cost of padding (the cushion under the carpet).
- Find the cost of all materials (carpet plus padding).
- Give the total area to a retailer or dealer and request an estimate for installing the carpet and padding. How much do you save if you install the carpet yourself?

Note: When estimating area you can check your work by searching the Web for a “carpet calculator.” It will calculate the area in square feet and square yards.

Painters

In charge of estimating the cost of the paint for the three rooms. *Hint:* Each room has four walls (ignore doors, windows, and ceilings), and we assume that the ceiling (and consequently each wall) is 8 feet tall.

- Find the area of the four walls in each room.
- Find the area of all walls in the three rooms.
- Find the cost of a gallon of wall paint (call several paint stores or find the prices online).
- Find how many gallons of paint you need. The industry standard for coverage is about 400 square feet per gallon, that is, you can paint 400 square feet of wall with one gallon of paint. *Note:* You can check with a paint calculator by doing a Web search.
- Find the cost of the paint.

Of course, you need brushes, cleaning materials, and paper or a tarp to cover the floor. For more information on measuring rooms and paint coverage, try a Web search.

Gardeners

We shall not neglect the outside of the house, so we shall install sod in our lawn.

Sod is usually sold in rectangles measuring 5 square feet (15 inches by 48 inches) or by pallets bringing 500 square feet per pallet. Dimensions and pallet sizes vary!

Assume our lawn is 40 feet by 50 feet.

1. Find the area of the lawn.
2. How many pallets of sod do we need?
3. What is the cost of each pallet (delivered)? Find the price for the sod by calling sod farms or searching online.
4. After you find the area of the lawn, call a sod farm and ask for the installed price of sod (per square foot).
5. Find the installed price of the sod for our lawn.
6. Compare the installed price and the do-it-yourself price. How much do you save if you install the sod yourself?

To find more information about sod, try a Web search for “sod installation.”

Research Questions

1. There is a charming story about the long-accumulated used wooden tally sticks mentioned in *The Human Side of Mathematics* at the beginning of this chapter. Find out how their disposal literally resulted in the destruction of the old Houses of Parliament in England.
2. Write a paper detailing the Egyptian number system and the base and symbols used, and enumerate the similarities and differences between the Egyptian and our (Hindu-Arabic) system of numeration.
3. Write a paper detailing the Greek number system and the base and symbols used, and enumerate the similarities and differences between the Greek and our system of numeration.
4. Find out about the development of the symbols we use in our present numeration system. Where was the symbol for zero invented and by whom?
5. Write a short paragraph discussing the development of the grouping symbols we have studied in this chapter.

Summary Chapter 1

Section	Item	Meaning	Example
1.1	Natural (Counting) numbers	1, 2, 3, and so on	19 and 23 are counting numbers.
	Digits	0, 1, 2, 3, 4, 5, 6, 7, 8, 9	
	Whole numbers	0, 1, 2, 3, and so on	0 and 17 are whole numbers.
1.1B	Expanded form	Numeral written with the ones, tens, hundreds, and so on displayed	$278 = 200 + 70 + 8$
1.2A	< (less than)	$a < b$ means that a is to the left of b on a number line.	$5 < 8$ and $0 < 9$

(continued)

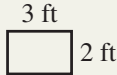
Section	Item	Meaning	Example
1.2A	> (greater than) Inequalities	$a > b$ means that a is to the <i>right</i> of b on a number line. Sentences using < or >	$8 > 5$ and $9 > 0$ $3 < 5$ and $8 > 2$
1.2B	Rounding	Approximating a given number to a specified number of digits	637 rounded to the nearest ten is 640; 637 rounded to the nearest hundred is 600.
1.3A	Addends Sum or total Identity for Addition Commutative Property of Addition Associative Property of Addition	The numbers to be added The result of an addition 0 is the identity for addition. $a + b = b + a$ $(a + b) + c = a + (b + c)$	In the sum $6 + 3 = 9$, 6 and 3 are the addends. The sum of 3 and 6 is 9. $0 + 5 = 5$, $9 + 0 = 9$. $5 + 4 = 4 + 5$ $(1 + 2) + 3 = 1 + (2 + 3)$
1.3B	Polygon Perimeter	A flat geometric region with many sides The distance around an object In the case of a polygon, the perimeter is the sum of the length of all sides.	 The perimeter of the rectangle  is $(3 + 2 + 3 + 2)$ ft = 10 ft.
1.4A	Minuend Subtrahend Difference	In $a - b = c$, a is the minuend. In $a - b = c$, b is the subtrahend. In $a - b = c$, c is the difference.	In $5 - 3 = 2$, 5 is the minuend. In $5 - 3 = 2$, 3 is the subtrahend. In $5 - 3 = 2$, 2 is the difference.
1.5A	Multiplicand Multiplier Product Factors	In $a \times b = c$, a is the multiplicand. In $a \times b = c$, b is the multiplier. In $a \times b = c$, c is the product. In $a \times b = c$, a and b are factors.	In $3 \times 5 = 15$, 3 is the multiplicand. In $3 \times 5 = 15$, 5 is the multiplier. In $3 \times 5 = 15$, 15 is the product. In $3 \times 5 = 15$, 3 and 5 are factors.
1.5A	Multiplication Property of Zero Commutative Property of Multiplication Identity for Multiplication Distributive Property	$0 \times a = 0 = a \times 0$ $a \times b = b \times a$ $1 \times a = a \times 1 = a$ $a \times (b + c) = (a \times b) + (a \times c)$	$0 \times 3 = 0$ and $5 \times 0 = 0$ $4 \times 7 = 7 \times 4$ $1 \times 4 = 4 \times 1 = 4$ $3 \times (20 + 3) = (3 \times 20) + (3 \times 3)$
1.5B	Multiples of 10	10, 100, 1000, etc.	$1000 \times 3 = 3000$
1.5C	Associative Property of Multiplication	$a \times (b \times c) = (a \times b) \times c$	$4 \times (2 \times 3) = (4 \times 2) \times 3$
1.5D	Area of rectangle	Multiply the length L by the width W .	The area of a rectangle 10 in. by 6 in. is 60 in.^2

Section	Item	Meaning	Example
1.6A	Dividend Divisor Quotient Division Properties of One Division Properties of Zero	In $a \div b = c$, a is the dividend. In $a \div b = c$, b is the divisor. In $a \div b = c$, c is the quotient. 1. $a \div a = 1$ ($a \neq 0$) 2. $a \div 1 = a$ 1. $0 \div a = 0$ ($a \neq 0$) 2. $a \div 0$ is undefined.	In $15 \div 3 = 5$, 15 is the dividend. In $15 \div 3 = 5$, 3 is the divisor. In $15 \div 3 = 5$, 5 is the quotient. $5 \div 5 = 1$ and $9 \div 9 = 1$ $7 \div 1 = 7$ and $10 \div 1 = 10$ $0 \div 17 = 0$ and $0 \div 3 = 0$ $7 \div 0$ is not defined.
1.7A	Prime number Composite number	A counting number having exactly two different factors, itself and 1 A counting number greater than 1 that is not prime	17 and 41 are prime. 22 and 48 are composite.
1.7B	Prime factors	The factors of a number that are prime numbers	The prime factors of 22 are 2 and 11.
1.7C	Base Exponent	In the expression b^n , b is the base. In the expression b^n , n is the exponent.	In the expression 2^3 , 2 is the base. In the expression 2^3 , 3 is the exponent.
1.7D	1 as an exponent 0 as an exponent	$a^1 = a$ $a^0 = 1$ ($a \neq 0$)	$9^1 = 9$ and $3^1 = 3$ $9^0 = 1$ and $3^0 = 1$
1.8A	Order of operations	PEMDAS (Parentheses, Exponents, Multiplication, Division, Addition, and Subtraction)	$36 \div 3 \times 6 - (3 + 4) + 5$ $= 36 \div 3 \times 6 - 7 + 5$ $= 12 \times 6 - 7 + 5$ $= 72 - 7 + 5$ $= 65 + 5$ $= 70$
1.9A	Equation Solution	A sentence using an = sign The solution of an equation is the replacement that makes the equation a true statement.	$10 = 2x$ and $x + 2 = 5$ are equations. The solution of $10 = 2x$ is 5.
1.9B	Equivalent equations The Addition Principle (Property) The Subtraction Principle (Property) The Division Principle (Property)	Two equations are equivalent if their solutions are the same. The equation $a = b$ is equivalent to $a + c = b + c$. The equation $a = b$ is equivalent to $a - c = b - c$. The equation $a = b$ is equivalent to $a \div c = b \div c$ ($c \neq 0$).	$2x + 1 = 3$ and $2x = 2$ are equivalent equations. The equation $x - 3 = 5$ is equivalent to $x - 3 + 3 = 5 + 3$. The equation $x + 3 = 5$ is equivalent to $x + 3 - 3 = 5 - 3$. The equation $2x = 6$ is equivalent to $2x \div 2 = 6 \div 2$.
1.9C	RSTUV procedure	R ead the problem. S elect the unknown. T ranslate the problem. U se the rules studied to solve the problem. V erify the answer.	

Review Exercises Chapter 1

If you need help with these exercises, look in the section indicated in brackets.

1. < 1.1A, B > Write in expanded form and find the value of the underlined digit.

- a. 127
- b. 189
- c. 380
- d. 1490
- e. 2559

2. < 1.1C > Write in standard form.

- a. $40 + 9$
- b. $500 + 80 + 6$
- c. $500 + 3$
- d. $800 + 10$
- e. $1000 + 4$

3. < 1.1D > Write the word name for these numbers.

- a. 79
- b. 143
- c. 1249
- d. 5659
- e. 12,347

4. < 1.1E > Write in standard form.

- a. Twenty-six
- b. One hundred ninety-two
- c. Four hundred sixty-eight
- d. One thousand, six hundred forty-four
- e. Forty-two thousand, eight hundred one

5. < 1.2A > Fill in the blank with $<$ or $>$ to make a true inequality.

- a. $27 \underline{\quad} 29$
- b. $30 \underline{\quad} 28$
- c. $23 \underline{\quad} 25$
- d. $19 \underline{\quad} 39$
- e. $39 \underline{\quad} 19$

6. < 1.2B > Round to the nearest hundred.

- a. 2848
- b. 9746
- c. 3550
- d. 4444
- e. 5555

7. < 1.2C > Round the price of the car to the nearest hundred dollars.

- a. \$21,090
- b. \$27,270
- c. \$35,540
- d. \$26,460
- e. \$22,990

8. < 1.3A > Add.

- a. $3402 + 8576$
- b. $2098 + 2383$
- c. $3099 + 6547$
- d. $4563 + 8603$
- e. $3480 + 9769$

9. < 1.3B > Find the perimeter of the triangle.

a.

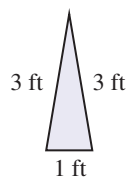

b.

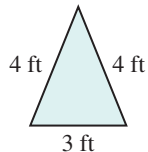

c.

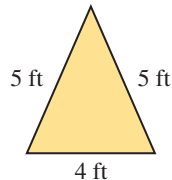

d.

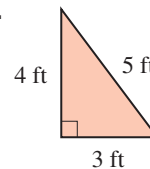

e.

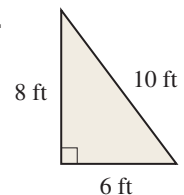

10. < 1.4A > Subtract.

- a. $47 - 18$
- b. $36 - 19$
- c. $55 - 26$
- d. $46 - 37$
- e. $93 - 44$

12. < 1.4B > The balance in a savings account is \$5403. How much money is left in the account if

- a. \$869 is withdrawn?
- b. \$778 is withdrawn?
- c. \$989 is withdrawn?
- d. \$676 is withdrawn?
- e. \$765 is withdrawn?

14. < 1.5A > Multiply.

- a. 123×216
- b. 231×413
- c. 345×654
- d. 231×843
- e. 879×569

16. < 1.5C > A person has a \$220 monthly payment. What is the total amount of money paid if

- a. 36 payments are required?
- b. 24 payments are required?
- c. 48 payments are required?
- d. 30 payments are required?
- e. 60 payments are required?

18. < 1.6A > Divide (if possible).

- a. $\frac{0}{2}$
- b. $\frac{0}{5}$
- c. $\frac{0}{12}$

20. < 1.6A > Divide.

- a. $75 \div 5$
- b. $84 \div 7$
- c. $90 \div 6$
- d. $88 \div 8$
- e. $68 \div 4$

11. < 1.4A > Subtract.

- a. $654 - 467$
- b. $547 - 458$
- c. $952 - 863$
- d. $851 - 673$
- e. $432 - 246$

13. < 1.5A > Multiply.

- a. 36×45
- b. 28×49
- c. 47×39
- d. 56×24
- e. 48×92

15. < 1.5B > Multiply.

- a. 330×234
- b. 220×546
- c. 550×324
- d. 450×124
- e. 490×892

17. < 1.5D > Find the area of a shortcake tray measuring:

- a. 36 in. by 10 in.
- b. 24 in. by 10 in.
- c. 30 in. by 12 in.
- d. 18 in. by 10 in.
- e. 24 in. by 12 in.

19. < 1.6A > Divide (if possible).

- a. $\frac{2}{0}$
- b. $\frac{5}{0}$
- c. $\frac{12}{0}$

21. < 1.6B > Divide.

- a. $279 \div 9$
- b. $378 \div 9$
- c. $824 \div 8$
- d. $126 \div 6$
- e. $455 \div 7$

22. < 1.6B > Divide.

- a. $21 \overline{)967}$
- b. $24 \overline{)1009}$
- c. $35 \overline{)876}$
- d. $29 \overline{)1074}$
- e. $51 \overline{)2450}$

24. < 1.7A > Classify as prime or composite (not prime).

- a. 41
- b. 26
- c. 37
- d. 81
- e. 2

26. < 1.7C > Write the number as a product of primes.

- a. 50
- b. 34
- c. 76
- d. 39
- e. 81

28. < 1.7D > Find the product by writing as a product of factors.

- a. $3^2 \times 5^3$
- b. $3^3 \times 8^0$
- c. $3^2 \times 5^2 \times 2^0$
- d. $5^0 \times 2^3 \times 5^2$
- e. $4^2 \times 9^0 \times 5^1$

30. < 1.8A > Simplify.

- a. $7 \cdot 8 - 2$
- b. $6 \cdot 8 - 3$
- c. $5 \cdot 8 - 4$
- d. $4 \cdot 8 - 5$
- e. $3 \cdot 8 - 5$

32. < 1.8A > Simplify.

- a. $48 \div 6 - (1 + 2)$
- b. $48 \div 8 - (2 + 2)$
- c. $48 \div 4 - (2 + 3)$
- d. $48 \div 3 - (2 + 4)$
- e. $48 \div 2 - (2 + 5)$

23. < 1.6C > A person's salary is \$11,232. How much does the person receive each pay period if the money is paid in

- a. 9 equal payments?
- b. 12 equal payments?
- c. 24 equal payments?
- d. 26 equal payments?
- e. 52 equal payments?

25. < 1.7B > Write the prime factors of these numbers.

- a. 40
- b. 25
- c. 75
- d. 128
- e. 68

27. < 1.7D > Find the product by writing as a product of factors.

- a. 2^2
- b. 3^2
- c. 5^3
- d. 2^7
- e. 3^5

29. < 1.7D > Find the product by writing as a product of factors.

- a. $2^2 \times 3 \times 8^0$
- b. $5^2 \times 7^0 \times 2^1$
- c. $3^3 \times 5^2 \times 6^0$
- d. $5^2 \times 3^0 \times 2^0$
- e. $5^0 \times 3^0 \times 2^0$

31. < 1.8A > Simplify.

- a. $30 + 4 \cdot 5$
- b. $31 + 5 \cdot 5$
- c. $32 + 6 \cdot 5$
- d. $33 + 7 \cdot 5$
- e. $34 + 8 \cdot 5$

33. < 1.8A > Simplify.

- a. $9 \div 3 \cdot 3 \cdot 3 + 3 - 1$
- b. $9 \div 3 \cdot 3 + 3 - 1$
- c. $8 \div 2 \cdot 2 \cdot 2 + 2 - 1$
- d. $8 \div 2 \cdot 2 + 2 - 1$
- e. $8 \div 4 \cdot 4 + 4 - 1$

34. < 1.8B > Simplify.

- a. $20 \div 5 + \{3 \cdot 9 - [3 + (5 - 2)]\}$
- b. $20 \div 5 + \{4 \cdot 9 - [3 + (5 - 3)]\}$
- c. $24 \div 6 + \{5 \cdot 9 - [3 + (5 - 4)]\}$
- d. $24 \div 4 + \{6 \cdot 9 - [3 + (5 - 5)]\}$
- e. $24 \div 3 + \{7 \cdot 9 - [3 + (5 - 1)]\}$

36. < 1.9A > Find the solution.

- a. $x + 6 = 18$
- b. $x + 7 = 18$
- c. $x + 8 = 18$
- d. $x + 9 = 18$
- e. $x + 10 = 18$

38. < 1.9A > Find the solution.

- a. $20 = 4x$
- b. $20 = 5x$
- c. $20 = 10x$
- d. $20 = 20x$
- e. $20 = 2x$

40. < 1.9B > Solve.

- a. $n - 10 = 11$
- b. $n - 14 = 12$
- c. $n - 27 = 13$
- d. $n - 48 = 14$
- e. $n - 18 = 15$

42. < 1.9B > Solve.

- a. $33 = 18 + m$
- b. $32 = 19 + m$
- c. $37 = 19 + m$
- d. $39 = 17 + m$
- e. $46 = 17 + m$

44. < 1.9B > Solve.

- a. $10 = 2x$
- b. $16 = 4x$
- c. $20 = 5x$
- d. $36 = 6x$
- e. $48 = 8x$

35. < 1.8C > A mechanic charges \$30 an hour plus parts to repair a car. If the parts cost \$80, find the total cost for a job that takes:

- a. 3 hours.
- b. 5 hours.
- c. 2 hours.
- d. 4 hours.
- e. 6 hours.

37. < 1.9A > Find the solution.

- a. $10 - x = 3$
- b. $10 - x = 4$
- c. $10 - x = 5$
- d. $10 - x = 6$
- e. $10 - x = 7$

39. < 1.9A > Find the solution.

- a. $28 \div x = 4$
- b. $24 \div x = 4$
- c. $20 \div x = 4$
- d. $16 \div x = 4$
- e. $12 \div x = 4$

41. < 1.9B > Solve.

- a. $20 = m - 12$
- b. $20 = m - 38$
- c. $11 = m - 14$
- d. $42 = m - 15$
- e. $49 = m - 16$

43. < 1.9B > Solve.

- a. $3x = 36$
- b. $4x = 52$
- c. $6x = 72$
- d. $7x = 63$
- e. $9x = 108$

45. < 1.9C > A building is 1430 feet tall. An antenna is added on the roof. Find the height of the antenna if the building is now:

- a. 1520 ft tall.
- b. 1530 ft tall.
- c. 1540 ft tall.
- d. 1515 ft tall.
- e. 1505 ft tall.

Practice Test Chapter 1

(Answers on page 111)

Visit www.mhhe.com/bello to view helpful videos that provide step-by-step solutions to several of the problems below.

- Write 348 in expanded form and find the value of the 3.
- Write 600 + 50 + 2 in standard form.
- Write 76,008 in words.
- Write eight thousand, five hundred ten in standard form.
- Fill in the blank with $<$ or $>$ to make a true inequality:
18 _____ 13
- Round 3749 to the nearest hundred.
- The price of a car is \$24,795. Round \$24,795 to the nearest hundred.
- $501 + 9786 =$
- Find the perimeter of a triangle with sides 24 inches, 18 inches, and 30 inches.
- $643 - 465 =$
- The balance in a savings account is \$4302. If \$978 is withdrawn, how much money is left in the account?
- $420 \times 381 =$
- A person must pay \$210 each month for 36 months. What is the total amount of money paid?
- Find the area of a rectangular frame measuring 20 inches by 8 inches.
- Divide: a. $\frac{0}{9}$ b. $\frac{9}{0}$
- Divide: $26 \overline{)885}$
- Divide: $328 \div 8$
- Is 49 a prime or a composite number?
- A person's annual salary of \$15,600 is paid in 12 equal monthly payments. How much does the person receive each month?
- Write the prime factors of 28.
- Write 60 as a product of primes.
- $2^2 \times 3^2 =$
- Simplify $3 \cdot 2^2 - 5$.
- $3^2 \times 5 \times 8^0 =$
- Simplify $15 \div 3 + \{2^2 \cdot 3 - [2 + (3 + 1)]\}$.
- Simplify $16 \div 4 \cdot 2^2 + 5 - 1$.
- Solve.
- A mechanic charges \$35 an hour plus parts to fix a car. If the parts cost \$90 and it took 3 hours to do the job, what is the total cost of the repair?
- Solve.
a. $10 = m - 6$ b. $30 = 20 + m$
- Solve.
a. $4x = 24$ b. $35 = 7x$
- A building is 1380 feet tall. An antenna is added on the roof of the building, which makes the building and antenna 1425 feet tall. How tall is the antenna?

> Answers to Practice Test Chapter 1

Answer	If You Missed		Review	
	Question	Section	Examples	Page
1. $348 = 300 + 40 + 8$; 300	1	1.1	1, 2, 3, 4, 5	3–4
2. 652	2	1.1	6, 7, 8	4–5
3. seventy-six thousand, eight	3	1.1	9	6
4. 8510	4	1.1	10, 11	6
5. $>$	5	1.2	1, 2	14
6. 3700	6	1.2	3, 4	16–17
7. \$24,800	7	1.2	5, 6, 7	17–19
8. 10,287	8	1.3	1–7	25–27
9. 72 in.	9	1.3	12	30
10. 178	10	1.4	1–8	38–43
11. \$3324	11	1.4	9, 10	44
12. 160,020	12	1.5	5, 6, 7	54–55
13. \$7560	13	1.5	9, 10, 11	56–57
14. 160 in.^2	14	1.5	12	58
15. a. 0 b. not defined	15	1.6	1, 2	64
16. 41	16	1.6	3, 4, 5	65–67
17. $34 \text{ r } 1$	17	1.6	6	67
18. \$1300	18	1.6	7, 8	67–68
19. composite	19	1.7	1	73
20. 2, 7	20	1.7	2	73
21. $2 \times 2 \times 3 \times 5 = 2^2 \times 3 \times 5$	21	1.7	3, 4	76–77
22. 36	22	1.7	5, 6	78
23. 45	23	1.7	5, 6	78
24. 7	24	1.8	1	84
25. 20	25	1.8	2, 3	84–85
26. 11	26	1.8	4	86
27. \$195	27	1.8	5, 6, 7	86–87
28. a. $m = 16$ b. $m = 10$	28	1.9	2, 3	93–94
29. a. $x = 6$ b. $x = 5$	29	1.9	4	94
30. 45 ft	30	1.9	5	96

This page intentionally left blank

Section

Chapter

- 2.1 Fractions and Mixed Numbers
- 2.2 Equivalent Fractions: Building and Reducing
- 2.3 Multiplication and Division of Fractions and Mixed Numbers
- 2.4 The Least Common Multiple (LCM)
- 2.5 Addition and Subtraction of Fractions
- 2.6 Addition and Subtraction of Mixed Numbers
- 2.7 Order of Operations and Grouping Symbols
- 2.8 Equations and Problem Solving

2

two

▶ Fractions and Mixed Numbers

The Human Side of Mathematics

As we mentioned in Chapter 1, the concept of a whole number is one of the oldest in mathematics. On the other hand, the concept of rational numbers or fractions (so named because they are ratios of whole numbers), developed much later because nonliterate tribes had no need for such a concept. Fractions evolved over a long period of time, stimulated by the need for certain types of measurement. For example, take a rod of length 1 unit and cut it into two equal pieces. What is the length of each piece? One-half, of course. If the same rod is cut into four equal pieces, then each piece is of length $\frac{1}{4}$. Two of these pieces will have length $\frac{2}{4}$, which tells us that $\frac{2}{4} = \frac{1}{2}$, as you will see later in the chapter. It was ideas such as these that led to the development of the arithmetic of fractions.

How were fractions written? During the Bronze Age, Egyptian hieroglyphic inscriptions show the reciprocals of whole numbers by using an elongated oval sign. Thus, $\frac{1}{8}$ and $\frac{1}{20}$ were written as

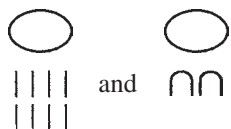

In this chapter, we study the operations with fractions that are the quotients of two whole numbers and their uses today.



2.1

Fractions and Mixed Numbers

▶ Objectives

You should be able to:

- A > Write a fraction corresponding to a given diagram.
- B > Classify a fraction as proper or improper.
- C > Write an improper fraction as a mixed number.
- D > Write a mixed number as an improper fraction.
- E > Solve applications using the concepts studied.

▶ To Succeed, Review How To . . .

1. Understand the basic arithmetic (+, −, ×, ÷) facts. (pp. 24, 37, 51, 63)
2. Use the definition of a counting number. (p. 2)

▶ Getting Started

In the cartoon, Sally is very upset with the idea of learning about **fractions**. The word *fraction* comes from the Latin word *fractio*, which means “to break” or “to divide.”

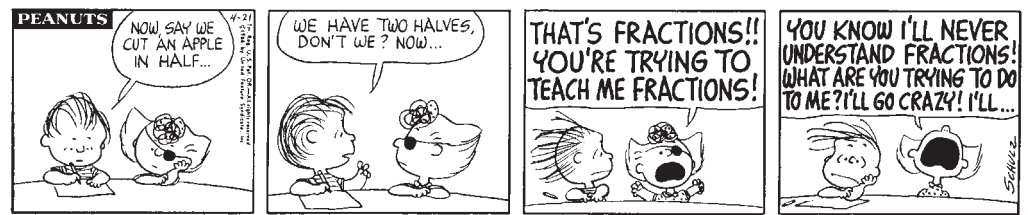

Peanuts: © United Features Syndicate, Inc.

A fraction is a number (usually written as $\frac{a}{b}$, where a and b are whole numbers and b is not 0) equal to the quotient of a divided by b . Fractions are used in everyday life. For example,

- $\frac{1}{3}$ of Americans do their grocery shopping at night.
- $\frac{7}{10}$ of all popcorn consumed is consumed at home.
- $\frac{3}{4}$ of all U.S. tomatoes are grown in California.
- $\frac{3}{10}$ of M&M's Plain Chocolate Candies are brown.



There are infinitely many fractions and some examples are $\frac{1}{3}$, $\frac{7}{10}$, $\frac{3}{4}$, and $\frac{3}{10}$. Look at the symbol $\frac{2}{3}$ on the measuring cup. The number above the bar (the top number) is called the **numerator** and the number below the bar (the bottom number) is called the **denominator**.

$$\frac{2}{3} \begin{array}{l} \leftarrow \text{numerator} \\ \leftarrow \text{denominator} \end{array}$$

The denominator of a fraction tells us the number of equal parts into which a whole has been divided and the numerator tells us how many of these parts are being considered. Thus $\frac{2}{3}$ tells us that the whole (a cup) has been divided into 3 equal parts and that 2 parts are being used.

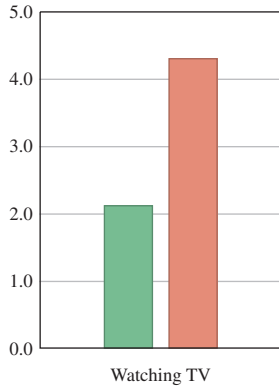

■ Ages 15-19
■ Ages 75 and over

Source: Bureau of Labor Statistics. The graph shows that the number of hours watching TV for 15- to 19-year-olds (green bar) is about half as much as that of persons 75 and over (orange bar).

A > Diagramming Fractions

To help us understand fractions, we can represent them by using a diagram such as the following:

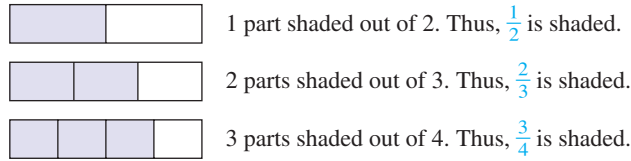

You can also show $\frac{1}{2}$, $\frac{2}{3}$, and $\frac{3}{4}$ using a shaded circle.

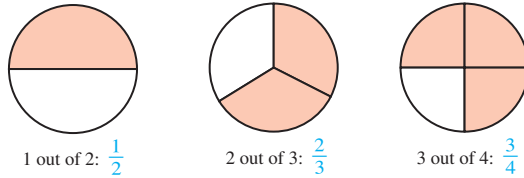

Or using portions of a **one-unit-long** line

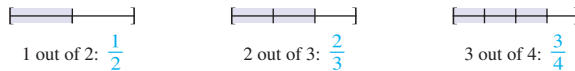

EXAMPLE 1 Using a diagram to represent fractions

Represent $\frac{3}{5}$ and $\frac{1}{4}$ by using a diagram similar to the ones shown above.

SOLUTION 1

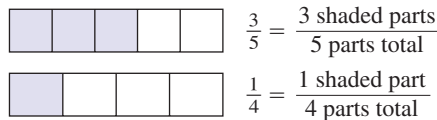

PROBLEM 1

Represent $\frac{2}{5}$ and $\frac{1}{7}$ in the diagrams below.



B > Proper and Improper Fractions

In Example 1, the fractions $\frac{3}{5}$ and $\frac{1}{4}$ are *less* than the whole that is used. Such fractions are called *proper fractions*.

DEFINITION OF A PROPER FRACTION

A proper fraction is a fraction in which the numerator is less (smaller) than the denominator.

Thus, $\frac{3}{5}$, $\frac{5}{16}$, $\frac{7}{32}$, and $\frac{99}{100}$ are proper fractions. On the other hand, some fractions such as $\frac{7}{7}$, $\frac{5}{1}$, or $\frac{14}{7}$ are *equal to* or **greater** (larger) than a whole. Such fractions are called *improper fractions*.

DEFINITION OF AN IMPROPER FRACTION

An improper fraction is a fraction in which the numerator is equal to or greater than the denominator.

Thus, $\frac{5}{5}$, $\frac{5}{2}$, $\frac{3}{3}$, $\frac{5}{1}$, and $\frac{17}{2}$ are improper fractions. Note that $\frac{5}{5}$ and $\frac{3}{3}$ both have the value 1. All improper fractions have values that are greater than or equal to 1. In general,

Answers to PROBLEMS

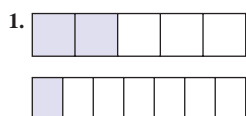

WRITING 1 AS A FRACTION

$$\frac{n}{n} = 1 \text{ for any number } n \neq 0$$

On the other hand, $\frac{5}{1} = 5$, $\frac{3}{1} = 3$, and $\frac{49}{1} = 49$. In general,

WRITING n AS A FRACTION

$$\frac{n}{1} = n \text{ for any number } n$$

WRITING 0 AS A FRACTION

$$\frac{0}{n} = 0 \text{ for any number } n \neq 0$$

Caution! $\frac{n}{0}$ is undefined.

EXAMPLE 2 Classifying fractions

Classify the given fraction as proper or improper.

- a. $\frac{15}{16}$ b. $\frac{17}{5}$ c. $\frac{8}{8}$ d. $\frac{0}{8}$ e. $\frac{8}{1}$

SOLUTION 2

- a. 15 is less than 16; thus, $\frac{15}{16}$ is a proper fraction (the numerator is less than the denominator).
 b. 17 is greater than 5; thus, $\frac{17}{5}$ is an improper fraction.
 c. 8 is equal to 8; thus, $\frac{8}{8}$ is an improper fraction.
 d. 0 is less than 8; thus, $\frac{0}{8}$ is a proper fraction.
 e. 8 is greater than 1; thus, $\frac{8}{1}$ is an improper fraction.

PROBLEM 2

Classify the given fraction as proper or improper.

- a. $\frac{6}{6}$ b. $\frac{3}{19}$ c. $\frac{19}{3}$
 d. $\frac{0}{3}$ e. $\frac{7}{1}$

C > Improper Fractions as Mixed Numbers

In Example 2 we mentioned that $\frac{17}{5}$ is an improper fraction. This fraction can also be written as a *mixed number*.

DEFINITION OF A MIXED NUMBER

A mixed number is a number representing the sum of a whole number and a proper fraction.

To write an improper fraction as a mixed number, divide the numerator by the denominator, obtaining the whole number part of the mixed number. The fractional part uses the remainder as numerator and the same denominator as the original fraction. Here is a diagram illustrating the procedure.

Note: Here is the diagram for $\frac{17}{5}$:

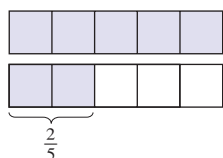
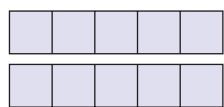

Do you see that this is $3 + \frac{2}{5}$?

Divide the numerator (17) by the denominator (5).

The answer (3) is the whole number part of the mixed number.

The remainder is the numerator of the fractional part.

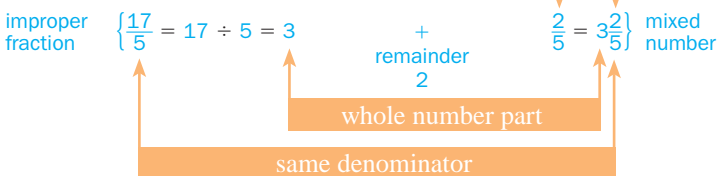

Answers to PROBLEMS

2. a. Improper b. Proper
 c. Improper d. Proper
 e. Improper

Note that $3\frac{2}{5} = 3 + \frac{2}{5}$, the sum of a whole number and a proper fraction. Similarly, $\frac{5}{3} = 1\frac{2}{3}$ and $\frac{8}{5} = 1\frac{3}{5}$.

EXAMPLE 3 Writing improper fractions as mixed numbers

Write as mixed numbers.

a. $\frac{23}{6}$

b. $\frac{47}{5}$

SOLUTION 3

a. $\frac{23}{6} = 3$ with a remainder of 5. Thus, $\frac{23}{6} = 3\frac{5}{6}$.

b. $\frac{47}{5} = 9$ with a remainder of 2. Thus, $\frac{47}{5} = 9\frac{2}{5}$.

PROBLEM 3

Write as mixed numbers.

a. $\frac{26}{5}$

b. $\frac{47}{6}$

D > Mixed Numbers as Improper Fractions

We can also rewrite a mixed number as an improper fraction. For example, to write $3\frac{1}{4}$ as an improper fraction, we think of $3\frac{1}{4}$ as a sum, where the 3 is expressed as $\frac{12}{4}$, as shown in the diagram.

$$3\frac{1}{4} = 3 + \frac{1}{4} = \frac{13}{4}$$

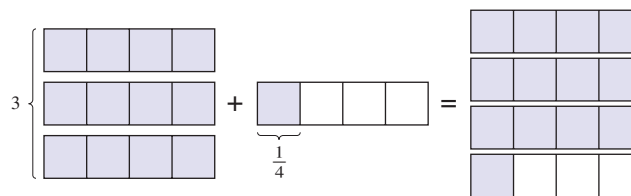

Here is a shortened form of this procedure (work clockwise from the denominator):

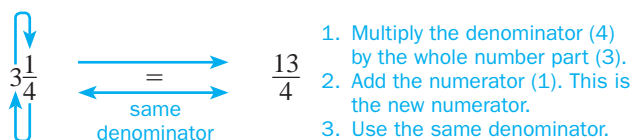

Here is the procedure. To write a mixed number as an improper fraction:

1. Multiply the denominator by the whole number part and add the numerator.
2. Use the number obtained in part 1 as the numerator of the improper fraction.
3. Use the same denominator.

EXAMPLE 4 Writing mixed numbers as improper fractions

Write as an improper fraction.

a. $6\frac{2}{7}$

b. $3\frac{1}{9}$

SOLUTION 4

a. $6\frac{2}{7} = \frac{7 \times 6 + 2}{7} = \frac{44}{7}$

b. $3\frac{1}{9} = \frac{9 \times 3 + 1}{9} = \frac{28}{9}$

PROBLEM 4

Write as an improper fraction.

a. $5\frac{3}{4}$

b. $8\frac{2}{7}$

Answers to PROBLEMS

3. a. $5\frac{1}{5}$ b. $7\frac{5}{6}$

4. a. $\frac{23}{4}$ b. $\frac{58}{7}$

E > Applications Involving Writing Fractions

Suppose you want to know what fraction of a pound (16 ounces) is in the 5-ounce can. Since the can contains 5 ounces and the whole pound is 16 ounces, the answer is $\frac{5}{16}$. Similarly, a week (7 days) is $\frac{7}{31}$ of the month of January (which has 31 days), and a weekend (2 days) is $\frac{2}{7}$ of a week. Note that in all these fractions, the numerator and denominator are expressed in the same type of unit.



EXAMPLE 5 Finding fractions of a week

Find what fraction of a week (7 days) each amount of days represents.

- a. 4 days b. 7 days c. 14 days

SOLUTION 5

- a. 4 days = $\frac{4}{7}$ week b. 7 days = $\frac{7}{7}$, or 1, week
 c. 14 days = $\frac{14}{7}$, or 2, weeks

PROBLEM 5

Find what fraction of a month (30 days) each amount of days represents.

- a. A week b. 30 days
 c. 60 days

What type of oil do you use for cooking? Here are the fat contents of nine different oils.

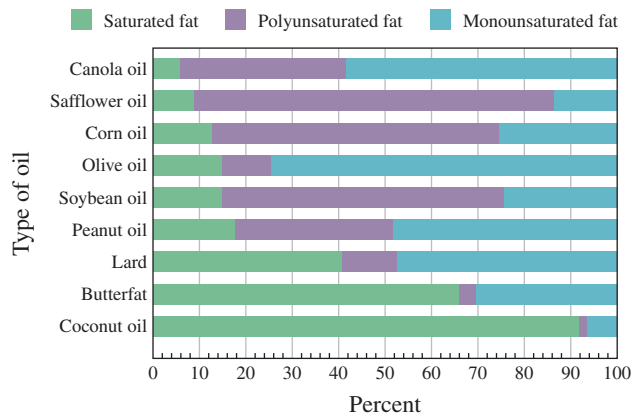

Source: NC State University.

Which oil has the most monounsaturated fat? Approximately what fraction of the oil is monounsaturated? Since monounsaturated fats are shown in blue, the oil with the most monounsaturated fat is olive oil, which is about $\frac{7}{10}$ monounsaturated fat. Why? The bar representing the olive oil is 10 units long and about 7 of them are blue, representing monounsaturated fats; thus

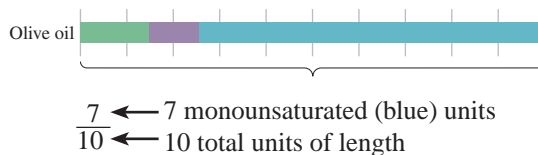

Answers to PROBLEMS

5. a. $\frac{7}{30}$ b. $\frac{30}{30} = 1$ c. $\frac{60}{30} = 2$

EXAMPLE 6 Looking for saturated fats

Referring to the preceding figure,

- Which oil has the most saturated fat?
- About what fraction of the fat in this oil is saturated?

SOLUTION 6

- Coconut oil has the most saturated fat.
- About nine (9) of the ten (10) units in the coconut oil bar are green. Thus, $\frac{9}{10}$ of the coconut oil is saturated fat.

PROBLEM 6

Referring to the figure,

- Which oil has the most polyunsaturated fat?
- About what fraction of the fat in this oil is polyunsaturated?

GREEN MATH

EXAMPLE 7 Water usage per day

How much water do you use each day? The average American uses as much as 101 gallons each day! The graph shows the water consumption at several locations in the home.

- In what location is the most water used?
- How many gallons per day are used in that location?
- What fraction of the total water is used in that location?

SOLUTION 7

- Toilet (shown gold)
- 27 gallons
- $\frac{27}{101}$

You can save between 3 and 5 gallons of water by cutting your shower short by one minute or flushing your toilet unnecessarily.

PROBLEM 7

- In what location is the least water used?
- How many gallons per day are used in that location?
- What fraction of the total water is used in that location?

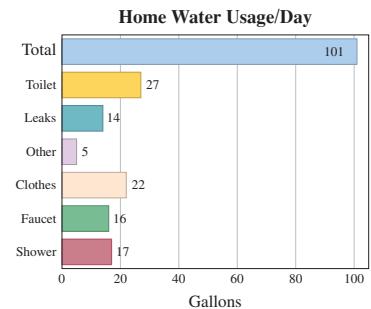

Many applications of fractions involve the idea of a ratio. A **ratio** is a quotient of two numbers.

RATIO

The ratio of a to b is written as the fraction $\frac{a}{b}$ ($b \neq 0$).

For example, the ratio of men to women in your class may be $\frac{19}{21}$ or $\frac{22}{31}$.

EXAMPLE 8 Price-to-earnings ratio of stock

The price-to-earnings (P/E) ratio of a stock is the price of the stock divided by its earnings per share. If the price of a stock is \$30 and its earnings per share are \$3, what is the P/E ratio of the stock?

SOLUTION 8 The P/E ratio is $\frac{30}{3} = 10$

PROBLEM 8

What is the P/E ratio of a stock whose price is \$28 and whose earnings are \$4 per share?

Answers to PROBLEMS

6. a. safflower b. $\frac{8}{10}$ 7. a. Other b. 5 c. $\frac{5}{101}$ 8. $\frac{28}{4} = 7$



- > Practice Problems
- > Self-Tests
- > Media-rich eBooks
- > e-Professors
- > Videos

> Exercises 2.1

< A > Diagramming Fractions In Problems 1–10, what part of each object is shaded?

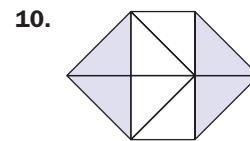
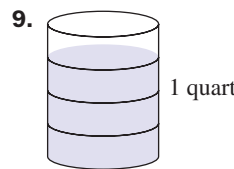
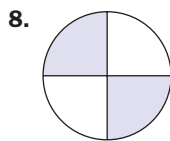
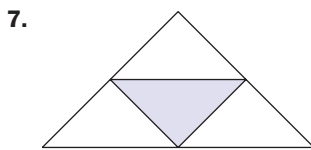
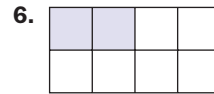
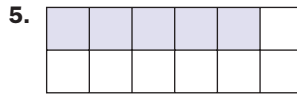
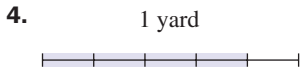
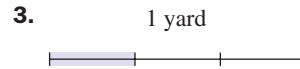
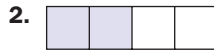
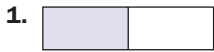

In Problems 11–20, what fraction of the dollar bill is green (not faded)?



< B > Proper and Improper Fractions In Problems 21–30, classify the fraction as proper or improper.

21. $\frac{9}{61}$ 22. $\frac{61}{9}$ 23. $\frac{4}{17}$ 24. $\frac{17}{4}$ 25. $\frac{8}{41}$
 26. $\frac{9}{47}$ 27. $\frac{8}{16}$ 28. $\frac{14}{1}$ 29. $\frac{3}{100}$ 30. $\frac{100}{10}$

< C > Improper Fractions as Mixed Numbers In Problems 31–40, write the fraction as a mixed number.

31. $\frac{31}{10}$ 32. $\frac{46}{5}$ 33. $\frac{8}{7}$ 34. $\frac{59}{8}$ 35. $\frac{29}{8}$
 36. $\frac{19}{2}$ 37. $\frac{69}{7}$ 38. $\frac{83}{3}$ 39. $\frac{101}{10}$ 40. $\frac{97}{3}$

< D > Mixed Numbers as Improper Fractions In Problems 41–50, write the mixed number as an improper fraction.

41. $5\frac{1}{7}$ 42. $6\frac{1}{9}$ 43. $4\frac{1}{10}$ 44. $5\frac{3}{11}$ 45. $1\frac{2}{11}$
 46. $3\frac{2}{13}$ 47. $8\frac{3}{10}$ 48. $7\frac{2}{11}$ 49. $2\frac{1}{6}$ 50. $9\frac{7}{8}$

< E > Applications Involving Writing Fractions

51. *Sleepy time* A person slept 7 hours. What fraction of the day (24 hours) is that?
52. *Fraction of an hour* Forty-five minutes is what fraction of an hour (60 minutes)?
53. *Fraction of a pound* A box of cereal weighs 7 ounces. What fraction of a pound (16 ounces) is that?
54. *Pizza fractions* A pizza was cut into 8 equal parts. Five pieces were eaten.
 a. What fraction of the pizza was eaten?
 b. What fraction of the pizza was left?
55. *Hours worked as fractions* A woman has worked for 5 hours. If her workday is 8 hours long, what fraction of the day has she worked?
56. *Fraction of reading* Sam Smart has to read 41 pages. He has already read 31. What fraction of the reading has he finished?
57. *Taxpayers' revenue* In a recent year the Internal Revenue Service collected 51 cents of every dollar (100 cents) of revenue from individual taxpayers. What fraction of the revenue came from individual taxpayers?
58. *Taxpayers' revenue* In a recent year the Internal Revenue Service collected 7 cents of every dollar (100 cents) of revenue from corporate taxes. What fraction of the revenue came from corporate taxes?
59. *Minutes in a commercial* A viewer made the following table showing the number of seconds various commercials lasted:
60. In Phoenix it rained 3 out of 31 days. What fraction of the 31 days is that?

Complete the table by filling in the number of minutes each commercial lasted. For example, the shampoo commercial lasted $\frac{30}{60}$ minutes.

Time of Commercials		
Commercial	Seconds	Minutes
Shampoo	30	$\frac{30}{60}$ or $\frac{1}{2}$
Dog food	60	a.
Toothpaste	90	b.
Soap	45	c.
Cereal	15	d.

The following information will be used in Problems 61–65.

Household overcrowding Is your household overcrowded? In a recent survey it was discovered that of every 98 households in America:

- 25 are single-person
- 33 are two-person
- 16 are three-person
- 15 are four-person
- 6 are five-person
- 2 are six-person
- 1 are seven-person or more

The following information will be used in Problems 66–70.

Traveling abroad Are you taking a trip soon? In a recent survey, it was discovered that of every 99 Americans who traveled abroad, their destinations were as shown.

1. Mexico	37	6. Italy	5
2. Canada	30	7. Japan	2
3. United Kingdom	8	8. Spain	2
4. France	6	9. Netherlands	2
5. Germany	5	10. Switzerland	2

Source: Infoplease.

FICO scores When you apply for credit—whether for a credit card, a car loan, or a mortgage—lenders want to know what risk they'd take by loaning money to you. Your FICO scores are the credit scores most lenders use to determine your credit risk. What are these scores based on? Look at the five categories in the pie chart!

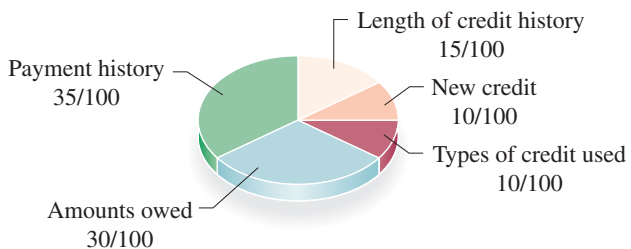

Source: <http://www.myfico.com>.

61. What fraction of the households consisted of a single person?
62. What fraction of the households consisted of three persons?
63. What fraction of the households consisted of five persons?
64. What fraction of the households consisted of five persons or more?
65. What fraction of the households consisted of six persons or more?

Source: U.S. Census Bureau.

66. What fraction of the travelers went to Germany?
67. What fraction of the travelers went to Mexico?
68. What fraction of the travelers went to Italy?
69. What fraction of the travelers went to Spain?
70. What fraction of the travelers went to Switzerland?

71. What reduced fraction of the score is based on your payment history?
72. What reduced fraction of the score is based on the amounts you owe?
73. What reduced fraction of the score is based on the length of your credit history?
74. What reduced fraction of the score is based on new credit?
75. What reduced fraction of the score is based on the types of credit used?
76. Which of the categories is the most important for your score?

>>> Applications: Green Math

Water withdrawn per day (408 billion gallons) The graph will be used in Exercises 77–80.

The different types of water users and their consumption of the 408 billion gallons used each day in the United States are shown.

Source: <http://pubs.usgs.gov/fs/2005/3051/>.

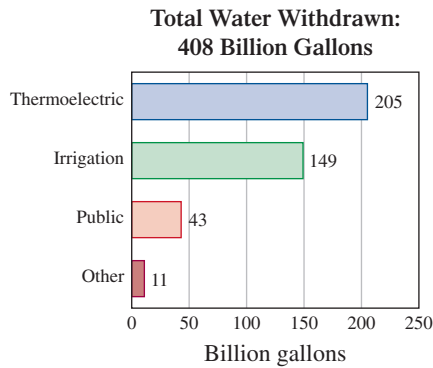

- 77.** Which of the categories uses the most water and what fraction of the water does it use?
- 78.** Which of the categories uses the least water and what fraction of the water does it use?
- 79.** What fraction of the 408 total billion gallons does the Public category use?
- 80.** What fraction of the 408 total billion gallons does Irrigation use?

Trashing and recycling e-waste The table is used in Exercises 81–86.

E-Waste—Was It Trashed or Recycled?

Products	Total disposed** (millions of units)	Trashed (millions of units)	Recycled (millions of units)
Televisions	27	21	6
Computer products*	206	157	50
Cell phones	140	127	13
Totals			

*Computer products include CPUs, monitors, notebooks, keyboards, mice, and “hard copy peripherals,” which are printers, copiers, and faxes.

**These totals don’t include products that are no longer used, but stored.

Source: EPA.

- 81.** How many million units are on the total disposed (blue) column? What fraction were televisions?
- 82.** What fraction of the products in the total disposed (blue) column are computer products?
- 83.** What fraction of the products in the total disposed (blue) column are cell phones?
- 84.** How many million units are on the trashed (green) column? What fraction were televisions?
- 85.** What fraction of the products in the trashed (green) column are computer products?
- 86.** What fraction of the products in the trashed (green) column are cell phones?

Using Your Knowledge

In Problems 87–90, indicate what fraction of the gas in the tank has been used and what fraction remains when:

- 87.** The gas gauge is on ①
- 88.** The gas gauge is on ②
- 89.** The gas gauge is on ③
- 90.** The gas gauge is on ④



How do you know how many miles per gallon your car gets? You look at the number (ratio) of miles traveled divided by the number of gallons of gas used. Thus, if your car travels 200 miles on 10 gallons of gas, your car gets $\frac{200}{10} = 20$ miles per gallon (mpg).

- 91.** Your car travels 180 miles on 10 gallons of gas. How many miles per gallon does your car get?
- 92.** You take a trip from Tampa to Miami, 260 miles. If you use 13 gallons of gas, how many miles per gallon does your car get?

93. You take a trip from Santa Rosa to Eureka, a distance of 210 miles. You use 10 gallons of gas. How many miles per gallon does your car get?
95. Your car gets 25 mpg. Your gas tank takes 14 gallons of gas. How far can you go on one tank of gas?
97. The distance from Monterey to Los Angeles is about 340 miles. Your car gets about 20 miles per gallon and the tank holds 14 gallons of gas. Can you make the trip on one tankful of gas? Explain.
99. Your car gets 20 mpg. You want to travel from Las Vegas to Ely, a distance of 240 miles. What is the capacity of the smallest gas tank that would get you to Ely?
94. You know you can make it from Los Angeles to Long Beach, a distance of 23 miles, on one gallon of gas. How many miles per gallon does your car get?
96. You want to travel from Los Angeles to Lone Pine, a distance of 220 miles. Your car gets 20 mpg. How many gallons of gas do you need?
98. You want to travel from Eureka to San Francisco, a distance of 260 miles. If your car gets 20 mpg and you use exactly one tank of gas, what is the capacity of your gas tank?
100. Your gas tank holds 14 gallons of gas. If you want to go to San Jose from Eureka, a distance of 322 miles, what is the minimum mpg your car can get so you reach your destination using one tank of gas?

>>> Write On

101. Write in your own words why $\frac{n}{0}$ is not defined. Can $n = 0$? Explain.
102. Write in your own words why $\frac{0}{n} = 0$. Can $n = 0$?
103. Write in your own words why $\frac{n}{1} = n$. Can $n = 0$?

>>> Concept Checker

Fill in the blank(s) with the correct word(s), phrase, or mathematical statement.

104. In the fraction $\frac{a}{b}$ the a is the _____.
105. In the fraction $\frac{a}{b}$ the b is the _____.
106. A **proper fraction** is a fraction in which the **numerator** is _____ than the **denominator**.
107. An **improper fraction** is a fraction in which the **numerator** is equal to or _____ than the **denominator**.
108. $\frac{0}{n} =$ _____ for any nonzero number n .
109. $\frac{n}{0}$ is _____ for any n .
110. A **mixed number** is a number representing the _____ of a **whole number** and a **proper fraction**.
111. The **ratio of a to b** ($b \neq 0$) is written as the **fraction** _____.

n	sum
numerator	denominator
less	0
$\frac{b}{a}$	greater
difference	$\frac{a}{b}$
well	undefined

>>> Mastery Test

112. If the price of a stock is \$48 and its earnings are \$12 per share, what is the P/E ratio of the stock?
113. What fraction of a year is 5 months?
114. Write $7\frac{2}{3}$ as a proper fraction.
115. Write $\frac{25}{3}$ as a mixed number.
116. Is $\frac{17}{18}$ a proper or an improper fraction?
117. Is $\frac{17}{17}$ a proper or an improper fraction?
118. Represent $\frac{2}{5}$ by drawing and shading a diagram.

>>> Skill Checker

Write as a product of primes using exponents.

119. 36
120. 90
121. 28
122. 72
123. 180
124. 200

2.2

Equivalent Fractions: Building and Reducing

▶ Objectives

You should be able to:

- A > Write a fraction equivalent to a given one and with a specified numerator or denominator.
- B > Reduce a fraction.
- C > Solve applications involving the concepts studied.

▶ To Succeed, Review How To . . .

1. Distinguish the meaning of the symbols $>$ and $<$. (p. 14)
2. Write a composite number as a product of primes. (pp. 74–77)

▶ Getting Started



The picture above illustrates the fact that one-half (dollar) is *equivalent* to two quarters. In symbols we write

$$\frac{1}{2} = \frac{2}{4}$$

When two fractions represent numerals or names for the same number, the fractions are said to be *equivalent*.

The following diagram shows that $\frac{1}{2}$, $\frac{2}{4}$, $\frac{3}{6}$, and $\frac{4}{8}$ are equivalent fractions.

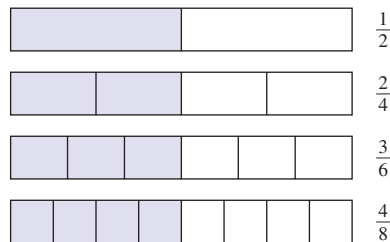

Thus, $\frac{1}{2} = \frac{2}{4} = \frac{3}{6} = \frac{4}{8}$ and so on.

A > Equivalent Fractions

EQUIVALENT
FRACTIONS

Two fractions are **equivalent** if they have the same value, that is, both fractions represent numerals or names for the same number.

The fraction $\frac{1}{2}$ is *equivalent* to many other fractions. We can always obtain fractions equivalent to any given fraction by **multiplying** both the **numerator** and **denominator** of the original fraction by the same nonzero number. In symbols,

FUNDAMENTAL PROPERTY OF FRACTIONS

If a , b , and c are any numbers, then

$$\frac{a}{b} = \frac{a \cdot c}{b \cdot c} \quad (b \neq 0 \text{ and } c \neq 0)$$

and

$$\frac{a}{b} = \frac{a \div c}{b \div c} \quad (b \neq 0 \text{ and } c \neq 0)$$

This property means that you can multiply or divide the numerator and denominator of the fraction $\frac{a}{b}$ by the same nonzero number c and obtain the equivalent fraction $\frac{a \cdot c}{b \cdot c}$ or $\frac{a \div c}{b \div c}$. In fact, this is the same as multiplying (or dividing) the fraction by $\frac{c}{c} = 1$. For example,

$$\begin{aligned} \frac{1}{3} &= \frac{1 \times 2}{3 \times 2} = \frac{2}{6} \\ \frac{1}{3} &= \frac{1 \times 3}{3 \times 3} = \frac{3}{9} \\ \frac{1}{3} &= \frac{1 \times 4}{3 \times 4} = \frac{4}{12} \end{aligned}$$

Thus, $\frac{1}{3} = \frac{2}{6} = \frac{3}{9} = \frac{4}{12}$. Can we find a fraction equivalent to $\frac{3}{5}$ with a denominator of 20? To do this we have to solve this problem:

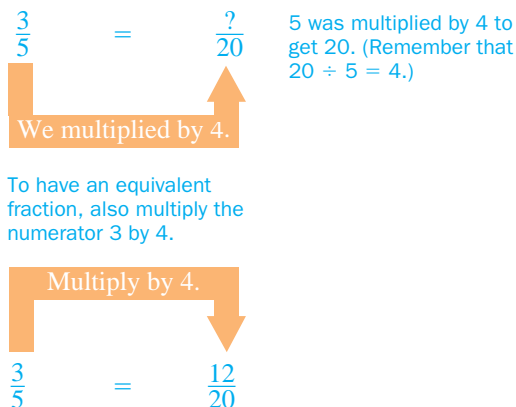

EXAMPLE 1 Finding equivalent fractions

Find the equivalent fractions.

a. $\frac{2}{3} = \frac{?}{9}$

b. $\frac{3}{8} = \frac{6}{?}$

SOLUTION 1

a. The denominator, 3, has to be multiplied by 3 to get a new denominator of 9. So, we multiply the numerator, 2, by 3. Here is the diagram.

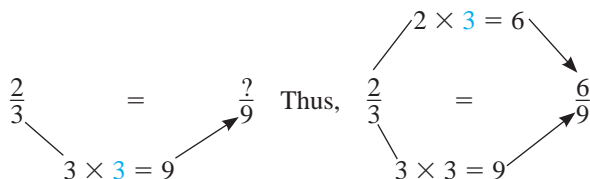

PROBLEM 1

Find the equivalent fractions.

a. $\frac{2}{7} = \frac{?}{28}$

b. $\frac{5}{6} = \frac{20}{?}$

Answers to PROBLEMS

1. a. $\frac{2}{7} = \frac{8}{28}$ b. $\frac{5}{6} = \frac{20}{24}$

- b. The numerator, 3, has to be multiplied by 2 to get the new numerator, 6. Thus we have to multiply the denominator, 8, by 2. (See the diagram.)

$$\frac{3}{8} = \frac{6}{?} \quad \text{Thus,} \quad \frac{3}{8} = \frac{6}{16}$$

Now here is a slightly different problem. Can we find a fraction equivalent to $\frac{15}{20}$ with a denominator of 4? To do this we have to solve this problem:

$$\frac{15}{20} = \frac{?}{4} \quad \text{20 was divided by 5 to get 4.}$$

We divided by 5.

$$\frac{15}{20} = \frac{3}{4} \quad \text{15 was divided by 5 to get 3.}$$

Divide by 5.

EXAMPLE 2 Finding equivalent fractions

Find the equivalent fractions.

a. $\frac{18}{24} = \frac{?}{8}$

b. $\frac{20}{30} = \frac{4}{?}$

SOLUTION 2

a. $\frac{18}{24} = \frac{?}{8}$ Thus, $\frac{18}{24} = \frac{6}{8}$

b. $\frac{20}{30} = \frac{4}{?}$ Thus, $\frac{20}{30} = \frac{4}{6}$

PROBLEM 2

Find the equivalent fractions.

a. $\frac{42}{54} = \frac{?}{18}$

b. $\frac{6}{20} = \frac{3}{?}$

B > Reducing Fractions

This rule can be used to **reduce** fractions to lowest terms:

REDUCING TO LOWEST TERMS

A fraction is *reduced to lowest terms* (simplified) when there are no common factors (except 1) in the numerator and denominator.

Answers to PROBLEMS

2. a. $\frac{42}{54} = \frac{14}{18}$ b. $\frac{6}{20} = \frac{3}{10}$

For example, to reduce $\frac{140}{154}$ to lowest terms, we proceed by steps:

Divide 140 by 2.	$\begin{array}{r} 2 \\ \hline 140 \\ 2 \\ \hline 70 \\ 5 \\ \hline 35 \\ 7 \\ \hline 7 \\ 1 \end{array}$	$\begin{array}{r} 2 \\ \hline 154 \\ 7 \\ \hline 77 \\ 11 \\ \hline 11 \\ 1 \end{array}$	Divide 154 by 2.
Divide 70 by 2.			Divide 77 by 7.
Divide 35 by 5.			Divide 11 by 11.
Divide 7 by 7.			

Step 1. Write the numerator and denominator as products of primes. (See Section 1.7.)

$$140 = 2 \times 2 \times 5 \times 7 \quad 154 = 2 \times 7 \times 11$$

$$\frac{140}{154} = \frac{2 \times 2 \times 5 \times 7}{2 \times 7 \times 11}$$

Step 2. Rewrite the fraction using the factored numerator and denominator.

$$\begin{aligned} \frac{140}{154} &= \frac{2 \times \cancel{2} \times 5 \times \cancel{7}}{\cancel{2} \times \cancel{7} \times 11} = \frac{2 \times 5}{11} \\ &= \frac{10}{11} \end{aligned}$$

Step 3. Divide the numerator and denominator by the common factors (2 and 7).

The division of 2 by 2 and 7 by 7 is indicated by crossing out 2 and 7 and writing the quotient, 1. Note that we actually divided numerator and denominator by $2 \times 7 = 14$, which is the **greatest common factor** (GCF) of 140 and 154. Thus

$$\frac{140}{154} = \frac{140 \div 14}{154 \div 14} = \frac{10}{11}$$

The reduction of $\frac{140}{154}$ is sometimes shown by dividing by 7 and then by 2 like this:

$\frac{10}{11}$	←	
$\frac{20}{22}$	←	
$\frac{140}{154}$	←	Divide by 7 first.
$\frac{140}{154}$	←	Divide by 2 next.
$\frac{22}{11}$	←	

The result is $\frac{10}{11}$. This method saves time. Use it!

Similarly, to reduce $\frac{60}{105}$ to lowest terms we proceed as before:

$$\frac{60}{105} = \frac{2 \times 2 \times \cancel{3} \times \cancel{5}}{\cancel{3} \times \cancel{5} \times 7} = \frac{4}{7}$$

We divide numerator and denominator by $3 \times 5 = 15$, the GCF of 60 and 105.

or, in the shortened version

$\frac{4}{7}$	←	
$\frac{20}{35}$	←	
$\frac{60}{105}$	←	Divide by 3 first.
$\frac{60}{105}$	←	Divide by 5 next.
$\frac{35}{7}$	←	

EXAMPLE 3 Simplifying fractions

Reduce (simplify) each fraction.

a. $\frac{15}{105}$

b. $\frac{36}{90}$

PROBLEM 3

Reduce (simplify) these.

a. $\frac{16}{80}$

b. $\frac{70}{155}$

Answers to PROBLEMS

3. a. $\frac{1}{5}$ b. $\frac{14}{31}$

SOLUTION 3

$$\text{a. } \frac{15}{105} = \frac{\overset{1}{\cancel{3}} \times \overset{1}{\cancel{5}}}{\underset{1}{\cancel{3}} \times \underset{1}{\cancel{5}} \times 7} = \frac{1}{7} \quad \text{or} \quad \begin{array}{r} \frac{15}{105} \\ \hline \frac{35}{35} \\ \hline \frac{1}{7} \end{array}$$

Divide by 3 first. Divide by 5 next.

Note that we divided 3 by 3, and 5 by 5, obtaining an answer of 1, which appears in the numerator and denominator of the fraction. You can also do the problem by dividing numerator and denominator by 15, the GCF of 15 and 105, obtaining

$$\frac{15}{105} = \frac{15 \div 15}{105 \div 15} = \frac{1}{7}$$

$$\text{b. } \frac{36}{90} = \frac{\overset{2}{\cancel{2}} \times \overset{1}{\cancel{2}} \times \overset{1}{\cancel{3}} \times \overset{1}{\cancel{3}}}{\underset{1}{\cancel{2}} \times \underset{1}{\cancel{3}} \times \underset{1}{\cancel{3}} \times 5} = \frac{2}{5} \quad \text{or} \quad \begin{array}{r} \frac{36}{90} \\ \hline \frac{18}{45} \\ \hline \frac{2}{5} \end{array}$$

Divide by 2 first. Divide by 3 next. Divide by 3 again.

The GCF of 36 and 90 is $2 \times 3 \times 3 = 18$.

You can also do the problem by dividing the numerator and denominator by 18 like this:

$$\frac{36}{90} = \frac{36 \div 18}{90 \div 18} = \frac{2}{5}$$

C > Applications Involving Reducing Fractions**EXAMPLE 4** Origin of the 24-second shot clock

Do you think professional basketball is boring? Danny Biasone (the owner of the Syracuse Nationals) thought the sport was boring. Biasone thought that a clock was necessary to force players to shoot at regular intervals and speed up the game. But how many seconds should be allowed between shots? Here is his reasoning: There are 48 minutes in a game, and $48 \times 60 = 2880$ seconds. An average game contained 60 shots per team, or $60 \times 2 = 120$ total shots. Thus, Biasone reasoned it should take $\frac{2880}{120}$ seconds per shot. Reduce $\frac{2880}{120}$.

SOLUTION 4 We first note that 2880 and 120 both end in 0, that is, they both have a factor of 10. We write: $\frac{288 \times 10}{12 \times 10} = \frac{288}{12}$. If you notice that 12 goes into 288 exactly 24 times, we are finished. Otherwise, write 288 and 12 as products of primes.

$$\begin{array}{r} 2 \overline{)288} \\ 2 \overline{)144} \\ 2 \overline{)72} \\ 2 \overline{)36} \\ 2 \overline{)18} \\ 3 \overline{)9} \\ 3 \overline{)3} \\ 1 \end{array} \quad \begin{array}{r} 2 \overline{)12} \\ 2 \overline{)6} \\ 3 \overline{)3} \\ 1 \end{array}$$

$$\frac{\overset{1}{\cancel{2}} \times \overset{1}{\cancel{2}} \times 2 \times 2 \times 2 \times 2 \times \overset{1}{\cancel{3}} \times 3}{\underset{1}{\cancel{2}} \times \underset{1}{\cancel{2}} \times \underset{1}{\cancel{3}}} = 24$$

And that is the way the 24-second shot clock was invented!

PROBLEM 4

Reduce $\frac{280}{120}$.

Answers to PROBLEMS

4. $\frac{7}{3}$

GREEN MATH

EXAMPLE 5 Use of social networks

Do you use Twitter, Facebook, or Myspace? Millions of people do!

Rank	Site	UV	Monthly Visits	Previous Rank
1	facebook.com	68,557,534	1,191,373,339	2
2	myspace.com	58,555,800	810,153,536	1
3	twitter.com	5,979,052	54,218,731	22

The UV column lists the number of unique visitors in January 2009 for each of the networks. (UV means that if you visit more than once, you are counted only once.)

- Round each of the numbers in the UV column to the nearest 10 million.
- How many unique visitors (after rounding) are there?
- What reduced fraction of the (rounded) unique visitors used Facebook?

SOLUTION 5

- a. To round 68,557,534 to the nearest 10 million,

- Underline the ten's million place, the 6. $\underline{68},557,534$
- The number to the right of 6 is 8. Change 6 to 7. $78,557,534$
- Change all numbers to the right of 7 to 0's. $70,000,000$

Thus, $68,557,534 \approx 70,000,000$ or 70 million

Similarly, $58,555,800 \approx 60,000,000$ or 60 million

and $5,979,052 \approx 6,000,000$ or 6 million

- b. There are $70 + 60 + 6 = 136$ million UV visitors.

- c. 70 million out of 136 million, or $\frac{70}{136} = \frac{35}{68}$.

Source: <http://tinyurl.com/czsls9>.

PROBLEM 5

What reduced fraction of the unique visitors (after rounding) use Myspace and what reduced fraction use Twitter?



Calculator Corner

Some calculators are designed to work with fractions. If you have such a calculator and you want to find a fraction equivalent to $\frac{12}{30}$ with a denominator of 10, the calculator has a key often labeled $\frac{x}{y}$ that allows you to reduce fractions. To simplify (reduce) $\frac{15}{20}$ enter $15 \frac{x}{y} 20$ **ENTER** and tell the calculator to **simplify** the result by pressing **SIMP**, the calculator asks you what factor you want to divide numerator and denominator by. You have to know that you want to divide numerator and denominator by 5, so enter 5 **ENTER** and the answer $\frac{3}{4}$ appears. To reduce $\frac{12}{30}$ to lowest terms, enter $12 \frac{x}{y} 30$ **ENTER** **SIMP**. The calculator asks FACTOR? Enter 6 and press **ENTER** and you get the answer $\frac{2}{5}$. Here, you are dividing the numerator and denominator of $\frac{12}{30}$ by 6.

> Exercises 2.2



> Practice Problems > Self-Tests
> Media-rich eBooks > e-Professors > Videos

< **A** > **Equivalent Fractions** In Problems 1–16, find the missing number.

1. $\frac{3}{5} = \frac{?}{50}$

2. $\frac{1}{8} = \frac{4}{?}$

3. $\frac{1}{6} = \frac{5}{?}$

4. $\frac{7}{9} = \frac{?}{27}$

5. $\frac{3}{5} = \frac{27}{?}$

6. $\frac{7}{12} = \frac{?}{60}$

7. $1\frac{2}{3} = \frac{?}{9}$

8. $2\frac{1}{5} = \frac{?}{15}$

Answer to PROBLEMS

5. $\frac{15}{34}$ and $\frac{3}{68}$

9. $4\frac{1}{2} = \frac{?}{16}$ 10. $5\frac{1}{10} = \frac{?}{90}$ 11. $\frac{12}{15} = \frac{?}{5}$ 12. $\frac{14}{42} = \frac{?}{6}$
 13. $\frac{8}{24} = \frac{4}{?}$ 14. $\frac{12}{18} = \frac{4}{?}$ 15. $\frac{21}{56} = \frac{?}{8}$ 16. $\frac{36}{180} = \frac{?}{5}$

◀ B ▶ Reducing Fractions In Problems 17–30, reduce each fraction to lowest terms.

17. $\frac{28}{30}$ 18. $\frac{15}{12}$ 19. $\frac{13}{52}$ 20. $\frac{27}{54}$ 21. $\frac{56}{24}$
 22. $\frac{56}{21}$ 23. $\frac{21}{28}$ 24. $\frac{18}{24}$ 25. $\frac{22}{33}$ 26. $\frac{100}{25}$
 27. $\frac{45}{210}$ 28. $\frac{180}{160}$ 29. $\frac{231}{1001}$ 30. $\frac{91}{455}$

◀ C ▶ Applications Involving Reducing Fractions

31. *Personal income taxes* In a recent year, 46 cents out of every dollar (100 cents) of revenue came from personal income taxes. What (reduced) fraction of the revenues is that?
32. *Corporate income taxes* In a recent year, 8 cents out of every dollar (100 cents) of revenue came from corporate income taxes. What (reduced) fraction of the revenues is that?
33. *Defense* The predicted defense budget for 2008 is \$460 billion. The predicted total budget is \$2760 billion. What (reduced) fraction of the budget will be spent on defense?
Source: The White House.
34. *Temperature* In Alabama, about 20 days out of the year (365 days) have temperatures less than 32 degrees Fahrenheit. What (reduced) fraction of the days is that?
35. *Temperature* In West Virginia, 100 days of the year (365 days) have temperatures less than 32 degrees Fahrenheit. What (reduced) fraction of the days is that?
36. *Water usage* A recent survey determined that the average household uses 80 gallons of water a day. If you fill your tub, 36 gallons are used. What (reduced) fraction of the water used per day is the 36 gallons?
Source: Center for Innovation in Engineering and Science Education.
37. *Cards* A standard deck of cards consists of 52 cards. Which (reduced) fraction of the deck is each of the following?
 a. Red (26 cards are red)
 b. Hearts (13 cards are hearts)
 c. Kings (4 cards are kings)
38. *Baseball* A baseball player collected 210 hits in 630 times at bat. What (reduced) fraction of the time did he get a hit?
39. *Recipes* A recipe calls for $\frac{3}{5}$ cup of sugar. Another recipe calls for $\frac{1}{2}$ cup. Which recipe takes more sugar?
40. *Waste* In a recent year, about 10,000 tons of waste materials were dumped into the ocean. Of these 4500 tons were sewage.
 a. What (reduced) fraction of the waste materials was sewage?
 b. In the following year about $\frac{1}{5}$ of the waste materials dumped into the ocean were sewage. Proportionately, in which year was the dumping of sewage greater?

The following information will be used in Problems 41–44.

Housework study The New York State College of Human Ecology at Cornell University conducted a study of housework. The study found that the average housewife puts 8 hours a day into housework. What about the husband? He does only 96 minutes a day! Here is what the husband does in his 96 minutes of chores:

Cleaning	36 minutes
Kitchen work	12 minutes
Caring for the family	24 minutes
Shopping and paperwork	24 minutes

The following information will be used in Problems 45–47.

Big Mac A Big Mac weighs 200 grams and provides

25 grams of protein
40 grams of carbohydrates
35 grams of fat

41. What (reduced) fraction of his time does the husband use in shopping and paperwork?
42. What (reduced) fraction of his time does the husband use in cleaning?
43. What (reduced) fraction of his time does the husband use in doing kitchen work?
44. What (reduced) fraction of his time does the husband use in caring for the family?
45. What (reduced) fraction of a Big Mac is protein?
46. What (reduced) fraction of a Big Mac is carbohydrates?
47. What (reduced) fraction of a Big Mac is fat?

The following information will be used in Problems 48–50.

Two slices of a 12-inch Domino's cheese pizza weigh 140 grams and provide:

- 18 grams of protein
- 52 grams of carbohydrates
- 6 grams of fat

48. What (reduced) fraction of the 2 slices is protein?
 49. What (reduced) fraction of the 2 slices is carbohydrates?
 50. What (reduced) fraction of the 2 slices is fat?

	Serving Size (g)	Calories	Calories from Fat	Total Fat (g)	Saturated Fat (g)	Trans Fats (g)	Cholesterol (mg)	Sodium (mg)	Carbohydrates (g)	Dietary Fiber (g)	Sugars (g)	Protein (g)
6" Bourbon Chicken (Subway)	258	350	45	5.0	1.5	0	50	1020	54	4	16	25
Tendergrill™ Chicken Sandwich w/Honey Mustard (Burger King)	258	450	90	10	2	0	75	1210	53	4	9	37

Nutritional information The chart gives the nutritional information for a 6-inch Bourbon Chicken Sandwich from Subway and a Tendergrill Chicken Sandwich from Burger King. Each of the sandwiches weighs **258** grams.

51. What reduced fraction of the 258-gram serving size are total fat for each sandwich?
 a. Subway sandwich
 b. Burger King sandwich
52. What reduced fraction of the 258-gram serving size are trans fats for each sandwich?
 a. Subway sandwich
 b. Burger King sandwich
53. What reduced fraction of the 258-gram serving size are carbohydrates for each sandwich?
 a. Subway sandwich
 b. Burger King sandwich
54. What reduced fraction of the 258-gram serving size are dietary fibers for each sandwich?
 a. Subway sandwich
 b. Burger King sandwich
55. What reduced fraction of the 258-gram serving size are sugars for each sandwich?
 a. Subway sandwich
 b. Burger King sandwich
56. What reduced fraction of the 258-gram serving size are proteins for each sandwich?
 a. Subway sandwich
 b. Burger King sandwich

>>> Applications: Green Math

Cost of improvements and annual savings The table shows the added cost of making improvements and your annual savings.

Source: Green and Save: <http://www.greenandsave.com/>.

	Added Cost	Annual Savings
Programmable thermostat	\$115	\$180
Compact fluorescent lighting	\$60	\$80
Heating system tune-up	\$200	\$180
Water filters	\$200	\$104

57. What is the added cost of a programmable thermostat, and the annual savings? What reduced fraction of the annual savings is the added cost?
58. What is the added cost of a Compact Fluorescent Lighting, and the annual savings? What reduced fraction of the annual savings is the added cost?
59. What is the added cost of a Heating System Tune-up, and the annual savings? What reduced fraction of the annual savings is the added cost?
60. What is the added cost of water filters, and the annual savings? What reduced fraction of the annual savings is the added cost? Of all the improvements in problems 57–60, which is the best deal? (Best return on investment)

Using Your Knowledge

A **ratio** is not only a fraction but is also a way of comparing two or more quantities. (We will study ratios in more detail in Chapter 4.) For example, if in a group of 10 people, there are 3 women and 7 men, the ratio of women to men is

$$\frac{3}{7} \leftarrow \begin{array}{l} \text{Number of women} \\ \text{Number of men} \end{array}$$

On the other hand, if there are 6 women and 4 men in the group, the *reduced* ratio of men to women is

$$\frac{4}{6} = \frac{2}{3} \leftarrow \begin{array}{l} \text{Number of men} \\ \text{Number of women} \end{array}$$

Another way to write this ratio is “2 to 3.”

- 61.** A class is composed of 25 girls and 30 boys. Find the reduced ratio of girls to boys.
- 62.** Stock analysts consider the price-to-earnings (P/E) ratio when buying or selling stock. If the price of a certain stock is \$20 and its earnings are \$5, what is the P/E ratio of the stock?

- 63.** Do you know what the teacher–student ratio is in your school? For example, if your school has 5000 students and 250 teachers, the teacher–student ratio is

$$\frac{250}{5000} = \frac{1}{20}$$

This means that for every teacher there are 20 students.

- a.** Find the teacher-to-student ratio in a school with 200 teachers and 5600 students.
- b.** If a school wishes to maintain a $\frac{1}{20}$ ratio, and the enrollment goes up to 8000 students, you can find how many teachers you need by writing

$$\text{Ratio you want } \frac{1}{20} = \frac{?}{8000} \leftarrow \begin{array}{l} \text{Teachers you need} \\ \text{Students you have} \end{array}$$

How many teachers are needed?

Write On

- 64.** Write in your own words the meaning of the fundamental law of fractions.
- 65.** What does it mean when we say that two fractions are equivalent? Give examples of equivalent fractions.
- 66.** What does it mean when we say that a fraction is reduced to lowest terms? Give examples of fractions that are not reduced to lowest terms and the procedure that must be used to reduce them.
- 67.** Is there a difference between “simplify” and “reduce to lowest terms”? Explain.
- 68.** Write the procedure you use to find the GCF of two numbers.

Concept Checker

Fill in the blank(s) with the correct word(s), phrase, or mathematical statement.

- 69.** Two fractions are _____ if they **represent numerals** or **names** for the **same** number.
- 70.** The **Fundamental Property of Fractions** states that for any nonzero numbers a , b , and c , $\frac{a}{b} = \frac{a \cdot c}{b \cdot c}$.
- 71.** A **fraction** is _____ when **there are no common factors** (except 1) in the **numerator** and the **denominator**.
- 72.** To **compare** two fractions with **different** denominators, write both fractions with a **denominator** equal to the _____ of the **original** ones.

sum

reduced

product

equivalent

$$\frac{a \cdot c}{b \cdot c}$$

$$\frac{b \cdot c}{a \cdot c}$$

Mastery Test

- 73.** Find the fraction equivalent to $\frac{3}{5} = \frac{?}{25}$.
- 74.** Find the fraction equivalent to $\frac{4}{9} = \frac{24}{?}$.
- 75.** Find the fraction equivalent to $\frac{9}{75} = \frac{?}{25}$.
- 76.** Find the fraction equivalent to $\frac{54}{90} = \frac{6}{?}$.
- 77.** Reduce $\frac{20}{115}$.
- 78.** Reduce $\frac{54}{90}$.

Skill Checker

Write as an improper fraction.

79. $3\frac{3}{8}$

80. $6\frac{5}{7}$

81. $7\frac{9}{10}$

82. $9\frac{2}{11}$

83. $10\frac{2}{13}$

84. $11\frac{1}{5}$

2.3

Multiplication and Division of Fractions and Mixed Numbers

Objectives

You should be able to:

- A** > Multiply two fractions.
- B** > Multiply a mixed number by a fraction and vice versa.
- C** > Find the square or cube of a fraction or mixed number.
- D** > Divide a fraction by another fraction.
- E** > Divide a fraction by a mixed number.
- F** > Solve applications involving the concepts studied.
- G** > Find areas using multiplication of fractions.

To Succeed, Review How To . . .

Write a multiplication problem as a division problem (1.6). (pp. 63–64)

Getting Started

The photo shows 3 cups, each containing $\frac{1}{4}$ cup of sugar. How much sugar do they contain altogether? To find the answer we must multiply 3 by $\frac{1}{4}$, that is, we must find

$$3 \cdot \frac{1}{4}$$

We have 3 one-quarter cups of sugar, which make $\frac{3}{4}$ cup. Thus, to find the answer, we multiply 3 by $\frac{1}{4}$, obtaining

$$3 \cdot \frac{1}{4} = \frac{3}{4}$$

We can show the idea pictorially like this:

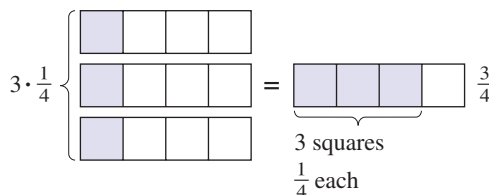

The diagram also suggests that multiplication is repeated addition; that is, $3 \times \frac{1}{4} = \frac{1}{4} + \frac{1}{4} + \frac{1}{4}$. Similarly, if a recipe calls for $\frac{1}{3}$ cup of flour and we wish to make only $\frac{1}{2}$ of the recipe, we have to find $\frac{1}{2}$ of $\frac{1}{3}$ (which means $\frac{1}{2} \times \frac{1}{3}$ because “of” is translated as “times”), that is, $\frac{1}{2} \cdot \frac{1}{3}$. Here is a diagram to help you do it.

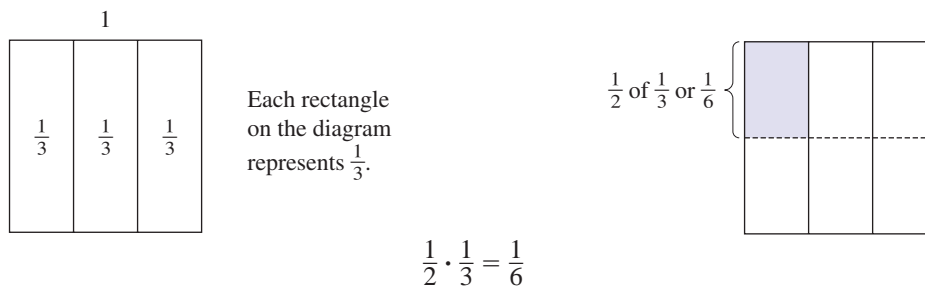

A > Multiplying Fractions

Note that we can also find the product of $\frac{1}{2}$ and $\frac{1}{3}$ like this:

$$\frac{1}{2} \cdot \frac{1}{3} = \frac{1 \cdot 1}{2 \cdot 3} = \frac{1}{6}$$

Similarly,

$$\frac{2}{5} \cdot \frac{3}{7} = \frac{2 \cdot 3}{5 \cdot 7} = \frac{6}{35}$$

and

$$\frac{3}{2} \cdot \frac{2}{5} = \frac{3 \cdot 2}{2 \cdot 5} = \frac{6}{10} = \frac{3}{5}$$

Notice that we reduced $\frac{6}{10}$, the answer obtained when multiplying $\frac{3}{2} \cdot \frac{2}{5}$.

In general, to multiply two fractions together, we multiply their numerators and their denominators.

RULE FOR MULTIPLYING FRACTIONS

The **product** of two fractions is a fraction whose *numerator* is the product of the *numerators* of the given fractions and whose *denominator* is the product of their *denominators*. In symbols,

$$\frac{a}{b} \cdot \frac{c}{d} = \frac{a \cdot c}{b \cdot d}$$

EXAMPLE 1 Multiplying fractions

Multiply.

a. $\frac{2}{7} \cdot \frac{3}{11}$

b. $\frac{3}{5} \cdot \frac{2}{3}$

SOLUTION 1

a. $\frac{2}{7} \cdot \frac{3}{11} = \frac{2 \cdot 3}{7 \cdot 11} = \frac{6}{77}$

b. $\frac{3}{5} \cdot \frac{2}{3} = \frac{3 \cdot 2}{5 \cdot 3} = \frac{6}{15} = \frac{2}{5}$

PROBLEM 1

Multiply.

a. $\frac{2}{5} \cdot \frac{4}{7}$

b. $\frac{3}{4} \cdot \frac{2}{3}$

When multiplying fractions it saves time if common factors are eliminated before you multiply. Thus, to multiply $\frac{1}{3}$ by $\frac{9}{10}$, we write

$$\frac{1}{\cancel{3}} \cdot \frac{\overset{3}{9}}{10} = \frac{3}{10}$$

Instead of writing

$$\frac{1}{3} \cdot \frac{9}{10} = \frac{1 \cdot 9}{3 \cdot 10} = \frac{9}{30} = \frac{\cancel{3} \cdot 3}{\cancel{3} \cdot 10} = \frac{3}{10}$$

we just divided numerator and denominator by the common factor 3 before multiplying.

Answers to PROBLEMS

1. a. $\frac{8}{35}$ b. $\frac{1}{2}$

B > Multiplication with Mixed Numbers

To multiply by a mixed number, write the mixed number as a fraction *first*, since our rule for multiplying states only how to multiply *fractions*. We illustrate this in Example 2.

EXAMPLE 2 Multiplying mixed numbers by fractions

Here is a recipe for hamburger. We wish to cut it in half (take $\frac{1}{2}$ of each ingredient).

- Find the amount of ground beef needed.
- Find the amount of veal needed.
- Find the amount of onion needed.
- Find the amount of salt needed.
- Find the amount of garlic salt needed.
- Find the amount of pepper needed.

Hamburger

$1\frac{1}{2}$ pounds ground beef

1 pound ground veal

$\frac{1}{4}$ cup minced onion

2 teaspoons salt

$\frac{1}{2}$ teaspoon garlic salt

$\frac{1}{3}$ teaspoon pepper

SOLUTION 2

- a. We need $\frac{1}{2} \cdot 1\frac{1}{2}$ pounds of ground beef. We first write $1\frac{1}{2}$ as $\frac{3}{2}$, then we multiply.

$$\frac{1}{2} \cdot 1\frac{1}{2} = \frac{1}{2} \cdot \frac{3}{2} = \frac{1 \cdot 3}{2 \cdot 2} = \frac{3}{4} \text{ pound of ground beef}$$

- b. We need $\frac{1}{2} \cdot 1$ pound of veal.

$$\frac{1}{2} \cdot 1 = \frac{1}{2}$$

Thus, we need $\frac{1}{2}$ pound of ground veal. Remember, any number multiplied by 1 equals the original number.

- c. Here we need $\frac{1}{2} \cdot \frac{1}{4}$ cup of onion.

$$\frac{1}{2} \cdot \frac{1}{4} = \frac{1 \cdot 1}{2 \cdot 4} = \frac{1}{8}$$

Thus, we need $\frac{1}{8}$ cup of minced onion.

- d. Now, we need $\frac{1}{2} \cdot 2$ teaspoons of salt. To multiply by a whole number such as 2, write the whole number as a fraction with denominator 1, that is, as $\frac{2}{1}$. Then multiply.

$$\frac{1}{2} \cdot 2 = \frac{1}{2} \cdot \frac{2}{1} = 1$$

Thus, we need 1 teaspoon of salt.

- e. This time we need $\frac{1}{2} \cdot \frac{1}{2}$ teaspoon of garlic salt.

$$\frac{1}{2} \cdot \frac{1}{2} = \frac{1 \cdot 1}{2 \cdot 2} = \frac{1}{4}$$

Thus, we need $\frac{1}{4}$ teaspoon of garlic salt.

- f. Finally, we need $\frac{1}{2} \cdot \frac{1}{3}$ teaspoon of pepper.

$$\frac{1}{2} \cdot \frac{1}{3} = \frac{1 \cdot 1}{2 \cdot 3} = \frac{1}{6}$$

Thus, we need $\frac{1}{6}$ teaspoon of pepper.

PROBLEM 2

We wish to make $\frac{1}{3}$ as much hamburger. Find the needed amount of each ingredient.

- Ground beef _____
- Veal _____
- Onion _____
- Salt _____
- Garlic salt _____
- Pepper _____

If you multiply a fraction by 1, you get the same fraction.

Answers to PROBLEMS

2. a. $\frac{1}{2}$ pound b. $\frac{1}{3}$ pound
 c. $\frac{1}{12}$ cup d. $\frac{2}{3}$ teaspoon
 e. $\frac{1}{6}$ teaspoon f. $\frac{1}{9}$ teaspoon

What did we learn from Example 2?

RULE TO MULTIPLY A FRACTION BY A MIXED NUMBER

1. To multiply a fraction by a mixed number, *first* convert the mixed number to a fraction. Thus,

$$3\frac{1}{7} \cdot \frac{2}{5} = \frac{22}{7} \cdot \frac{2}{5} = \frac{44}{35}$$

Convert to a fraction

2. Any fraction multiplied by 1 equals the fraction. Thus,

$$\frac{3}{19} \cdot 1 = \frac{3}{19}$$

3. To multiply a fraction by a whole number (such as 5), write the number as a fraction with a denominator of 1. Thus, write 5 as $\frac{5}{1}$ and multiply as shown.

$$5 \cdot \frac{3}{10} = \frac{5}{1} \cdot \frac{3}{10} = \frac{3}{2}$$

5 = $\frac{5}{1}$

What about multiplying more than two fractions? See Example 3!

EXAMPLE 3 Multiplying mixed numbers by fractions

Find $2\frac{1}{3} \cdot \frac{3}{5} \cdot \frac{5}{7}$.

SOLUTION 3 We first write $2\frac{1}{3}$ as $\frac{7}{3}$, and then we proceed as shown:

$$\frac{\cancel{7}^1}{3} \cdot \frac{\cancel{3}}{\cancel{5}} \cdot \frac{\cancel{5}}{\cancel{7}} = 1$$

Recall that $2\frac{1}{3} = \frac{2 \cdot 3 + 1}{3} = \frac{7}{3}$

The answer is 1.

PROBLEM 3

Find $3\frac{1}{4} \cdot \frac{4}{3} \cdot \frac{3}{13}$.

C > Exponents and Fractions

Do you remember what 3^2 means?

$$3^2 = 3 \cdot 3 = 9$$

What about $(\frac{2}{3})^2$?

$$(\frac{2}{3})^2 = \frac{2}{3} \cdot \frac{2}{3} = \frac{4}{9}$$

$(\frac{2}{3})^2$ means raising $\frac{2}{3}$ to the **second** power.

$$(\frac{2}{3})^3 = \frac{2}{3} \cdot \frac{2}{3} \cdot \frac{2}{3} = \frac{8}{27}$$

Here we raise $\frac{2}{3}$ to the **third** power.

We use these ideas in Example 4.

EXAMPLE 4 Raising a fraction or mixed number to a power

Evaluate.

a. $\left(\frac{3}{4}\right)^3$

b. $\left(1\frac{1}{5}\right)^2$

c. $\left(\frac{3}{4}\right)^2 \cdot \left(1\frac{1}{3}\right)$

SOLUTION 4

a. $\left(\frac{3}{4}\right)^3 = \frac{3}{4} \cdot \frac{3}{4} \cdot \frac{3}{4} = \frac{27}{64}$

b. We first write $1\frac{1}{5}$ as $\frac{6}{5}$. Thus,

$$\left(1\frac{1}{5}\right)^2 = \left(\frac{6}{5}\right)^2 = \frac{6}{5} \cdot \frac{6}{5} = \frac{36}{25}$$

c. $\left(\frac{3}{4}\right)^2 \cdot \left(1\frac{1}{3}\right) = \frac{3}{4} \cdot \frac{3}{4} \cdot \frac{4}{3} = \frac{3}{4}$

PROBLEM 4

Evaluate.

a. $\left(\frac{2}{5}\right)^3$

b. $\left(1\frac{1}{4}\right)^2$

c. $\left(\frac{2}{3}\right)^2 \cdot \left(2\frac{1}{4}\right)$

D > Division of Fractions

Now we are ready to do division!



Henry Serrano, Tampa, Florida

In the cartoon it is claimed that 5 will divide into 2 if you push it! What this means is that $2 \div 5$ is *not* a counting number but a fraction. Thus,

$$2 \div 5 = \frac{2}{5} = 2 \cdot \frac{1}{5}$$

multiply

The divisor is inverted.

Note that to divide 2 by 5 we *multiplied* 2 by $\frac{1}{5}$, where the fraction $\frac{1}{5}$ was obtained by *inverting* $5 = \frac{5}{1}$ to obtain $\frac{1}{5}$. (In mathematics, 5 and $\frac{1}{5}$ are called *reciprocals* of each other.) Here is the rule we need:

RULE FOR FINDING THE RECIPROCAL OF A FRACTION

To find the reciprocal of $\frac{a}{b}$, **invert** the fraction (interchange the numerator and denominator) to obtain $\frac{b}{a}$. This means that $\frac{a}{b}$ and $\frac{b}{a}$ are **reciprocals** of each other.

Answers to PROBLEMS

4. a. $\frac{8}{125}$ b. $\frac{25}{16}$ c. 1

Thus, the reciprocal of 5 is $\frac{1}{5}$, the reciprocal of $\frac{2}{3}$ is $\frac{3}{2}$, and the reciprocal of $\frac{5}{4}$ is $\frac{4}{5}$. Now let us try the problem $5 \div \frac{5}{7}$. If we try to do it like the previous problem we must multiply 5 by the reciprocal of $\frac{5}{7}$, that is,

$$5 \div \frac{5}{7} = 5 \cdot \frac{7}{5}$$

Since $5 = \frac{5}{1}$, $5 \cdot \frac{7}{5} = \frac{5}{1} \cdot \frac{7}{5} = 7$. Thus, $5 \div \frac{5}{7} = 7$. To check this answer we recall that any division problem can be written as an equivalent multiplication problem. Thus, the problem $12 \div 4 = \square$ can be written as $12 = 4 \cdot \square$. Similarly,

$$5 \div \frac{5}{7} = \square \quad \text{means} \quad 5 = \frac{5}{7} \cdot \square$$

What number can we place in the box so that $5 = \frac{5}{7} \times \square$? The answer is 7, since $\frac{5}{7} \times 7 = 5$. We now have a simple rule for dividing fractions:

RULE FOR DIVIDING FRACTIONS: INVERT THE DIVISOR

To divide $\frac{a}{b}$ by $\frac{c}{d}$, *invert* the divisor $\frac{c}{d}$ and multiply.

In symbols, $\frac{a}{b} \div \frac{c}{d} = \frac{a}{b} \cdot \frac{d}{c}$.

Note: You can also state this rule like this:

To divide $\frac{a}{b}$ by $\frac{c}{d}$, multiply $\frac{a}{b}$ by the *reciprocal* of $\frac{c}{d}$.

For example,

$$7 \div \frac{3}{5} = \frac{7}{1} \cdot \frac{5}{3} = \frac{35}{3}$$

Caution To divide by a fraction, we *invert the divisor only* and then multiply.

Recall that to *invert* means to switch the numerator and denominator. Thus, inverting $\frac{3}{5}$ gives $\frac{5}{3}$, inverting $\frac{1}{6}$ gives $\frac{6}{1}$, or 6, and inverting 2 gives $\frac{1}{2}$. Here are some more examples:

$$\frac{3}{4} \div \frac{5}{7} = \frac{3}{4} \cdot \frac{7}{5} = \frac{21}{20}$$

Check

$$\frac{3}{4} \div \frac{5}{7} = \frac{21}{20} \quad \text{because} \quad \frac{3}{4} = \frac{8}{8} \cdot \frac{21}{20}$$

$$\frac{5}{11} \div \frac{5}{7} = \frac{5}{11} \cdot \frac{7}{5} = \frac{7}{11}$$

Check

$$\frac{5}{11} \div \frac{5}{7} = \frac{7}{11} \quad \text{because} \quad \frac{5}{11} = \frac{5}{\cancel{7}} \cdot \frac{1}{\cancel{7}} \cdot \frac{7}{11}$$

EXAMPLE 5 Dividing by a fraction and by a whole number

Divide.

a. $\frac{3}{5} \div \frac{2}{7}$

b. $\frac{4}{9} \div 5$

SOLUTION 5

$$\text{a. } \frac{3}{5} \div \frac{2}{7} = \frac{3}{5} \cdot \frac{7}{\cancel{2}} = \frac{21}{10}$$

$$\text{b. } \frac{4}{9} \div 5 = \frac{4}{9} \cdot \frac{1}{5} = \frac{4}{45}$$

PROBLEM 5

Divide.

a. $\frac{5}{7} \div \frac{3}{8}$

b. $\frac{3}{4} \div 7$

E > Division with Mixed Numbers

As in the case of multiplication, if mixed numbers are involved, they are changed to improper fractions first, like this:

$$2\frac{1}{4} \div \frac{3}{5} = \frac{9}{4} \div \frac{3}{5} = \frac{9}{\cancel{4}} \cdot \frac{5}{\cancel{3}} = \frac{15}{4}$$

EXAMPLE 6 Division involving mixed numbers

Divide.

a. $3\frac{1}{4} \div \frac{7}{8}$

b. $\frac{11}{12} \div 7\frac{1}{3}$

SOLUTION 6

$$\text{a. } 3\frac{1}{4} \div \frac{7}{8} = \frac{13}{4} \div \frac{7}{8} = \frac{13}{\cancel{4}} \cdot \frac{8}{7} = \frac{26}{7}$$

$$\text{b. } \frac{11}{12} \div 7\frac{1}{3} = \frac{11}{12} \div \frac{22}{3} = \frac{11}{\cancel{12}} \cdot \frac{3}{\cancel{22}} = \frac{1}{8}$$

PROBLEM 6

Divide.

a. $5\frac{1}{2} \div \frac{3}{4}$

b. $\frac{6}{7} \div 3\frac{1}{7}$

F > Applications Involving Multiplying and Dividing Fractions

If you are considering purchasing a home, you need to figure out how much you can afford. Home and Garden Bulletin No. 182 (U.S. Dept. of Agriculture) suggests that a family spend no more than $2\frac{1}{2}$ times its total annual income for a home.

Answers to PROBLEMS

5. a. $\frac{40}{21}$ b. $\frac{3}{28}$ 6. a. $\frac{22}{3}$ b. $\frac{3}{11}$

EXAMPLE 7 Purchasing a home

Supposing your family has \$24,000 in total annual income, how much can you afford to pay for a home?

SOLUTION 7

or

$$\frac{5}{2} \cdot 24,000 = \frac{5}{2} \cdot \frac{12,000 \cdot 24,000}{1} = 60,000$$

$2\frac{1}{2}$ times 24,000
 ↓ ↓ ↓
 $\frac{5}{2}$ ↓ ↓ ↓ $\frac{12,000 \cdot 24,000}{1}$

Thus, your family can afford a \$60,000 home.

PROBLEM 7

A family has \$41,000 in total annual income. How much can it afford for a home?

EXAMPLE 8 Capacity of a bottle

The 2-in-1 toothpaste bottle contains 130 grams of gel. If you use $1\frac{1}{5} = \frac{6}{5}$ of a gram each time you brush your teeth, how many times can you brush with the 130 grams in the bottle?

SOLUTION 8 Since you have 130 grams of gel and you use $1\frac{1}{5}$ grams per application, you should be able to have $130 \div 1\frac{1}{5}$ brushings. Now, $130 \div 1\frac{1}{5} = 130 \div \frac{6}{5} = 130 \cdot \frac{5}{6} = \frac{650}{6} = 108\frac{1}{3}$ or about 108 brushings.

**PROBLEM 8**

How many brushings are possible if you use $1\frac{2}{3}$ grams each time you brush?

G > Applications: Finding Area

As you recall from Section 1.5,

AREA OF A RECTANGLE

The area A of a rectangle is found by multiplying its length L by its width W .

$$A = L \cdot W$$

Apply this formula in Examples 9 and 10.

EXAMPLE 9 Find the area of a room

A room measures $3\frac{1}{3}$ yd by $5\frac{2}{3}$ yd. How many square yards of carpet would it take to cover the floor?

SOLUTION 9 The area of the floor is: $3\frac{1}{3} \cdot 5\frac{2}{3} = \frac{10}{3} \cdot \frac{17}{3} = \frac{170}{9} = 18\frac{8}{9}$ yd² or almost 19 yd², so it takes about 19 square yards of carpet to cover the floor.

PROBLEM 9

Find the area of a room measuring $4\frac{1}{3}$ yards by $5\frac{2}{3}$ yards.

Answers to PROBLEMS

7. \$102,500 8. About 93 ($92\frac{6}{7}$)
 9. $24\frac{2}{3}$ yd²

The International Space Station uses rectangular solar panels measuring 115 ft by 38 ft. There are 8 of these panels, so they cover an area of $8 \times 115 \times 38$ square ft. (How much area is that?) You can use smaller panels covering less area and have your own solar electric system at home. See how much area a typical panel covers in Example 10.



GREEN MATH

EXAMPLE 10 Solar panels for the home

A typical 20-watt rectangular solar panel module measures 22 inches (in.) by $14\frac{3}{16}$ in. What area does such a panel cover?

SOLUTION 10

The area of a rectangle is found by multiplying the length by the width, that is, $22 \times 14\frac{3}{16}$. Now, $22 = \frac{22}{1}$ and $14\frac{3}{16} = \frac{227}{16}$. Thus,

$$22 \times 14\frac{3}{16} = \frac{22}{1} \times \frac{227}{16} = \frac{2497}{8} = 312\frac{1}{8}$$

So the panel covers $312\frac{1}{8}$ square inches. By the way, it costs \$140.

Source: <http://www.solarhome.org/11-20wattsolarpanels.aspx>.

PROBLEM 10

A 20-watt panel measures 20 in. by $16\frac{3}{16}$ in. What area does such a panel cover?



Calculator Corner

You can multiply and divide fractions with a scientific calculator. The difficulty is that your answer will be a decimal. Thus, to multiply $\frac{3}{5} \times \frac{5}{8}$ you enter 3 \div 5 \times 5 \div 8 **ENTER**. The display will show 0.375, which is the correct answer but in decimal form. With a fraction calculator with an $\frac{x}{y}$ key, you enter 3 $\frac{x}{y}$ 5 \times 5 $\frac{x}{y}$ 8 **ENTER**. The result is given as 15/40. But the answer is not in reduced form! To do that press **SIMP**. The calculator asks: FACTOR? The GCF here is 5, so enter 5 and press **ENTER**. The answer 3/8 is displayed.

You can also do multiplication involving mixed numbers if you know how to enter the mixed numbers. To do so you enter the whole number part first and then the fraction part. Thus, to enter $3\frac{4}{5}$, enter 3 **UNIT** 4 $\frac{x}{y}$ 5. If you now decide to multiply by 2, just enter \times 2 **ENTER**. If you want the answer $38/5$ displayed as a mixed number, press **A^{b/c}** and you get $7\frac{3}{5}$, which means $7\frac{3}{5}$.

Answers to PROBLEMS

10. $323\frac{3}{4}$ square inches

Exercises 2.3



> Practice Problems > Self-Tests
> Media-rich eBooks > e-Professors > Videos

A **Multiplying Fractions** In Problems 1–14, multiply (reduce answers to lowest terms).

- | | | | | |
|---------------------------------------|--------------------------------------|--------------------------------------|--------------------------------------|-------------------------------------|
| 1. $\frac{3}{4} \cdot \frac{7}{8}$ | 2. $\frac{2}{3} \cdot \frac{7}{3}$ | 3. $\frac{1}{6} \cdot \frac{6}{7}$ | 4. $\frac{5}{9} \cdot \frac{4}{5}$ | 5. $\frac{2}{5} \cdot \frac{5}{3}$ |
| 6. $\frac{6}{5} \cdot \frac{7}{6}$ | 7. $3 \cdot \frac{2}{5}$ | 8. $\frac{3}{4} \cdot 7$ | 9. $\frac{5}{6} \cdot \frac{3}{5}$ | 10. $\frac{7}{3} \cdot \frac{6}{7}$ |
| 11. $\frac{7}{5} \cdot \frac{15}{14}$ | 12. $\frac{2}{7} \cdot \frac{21}{8}$ | 13. $\frac{6}{7} \cdot \frac{14}{3}$ | 14. $\frac{21}{2} \cdot \frac{8}{7}$ | |

B **Multiplication with Mixed Numbers** In Problems 15–24, multiply (reduce answers to lowest terms).

- | | | | | |
|---------------------------------------|--------------------------------------|--------------------------------------|---------------------------------------|---------------------------------------|
| 15. $1\frac{2}{3} \cdot \frac{6}{5}$ | 16. $2\frac{1}{4} \cdot \frac{4}{7}$ | 17. $\frac{9}{4} \cdot 3\frac{1}{9}$ | 18. $\frac{2}{15} \cdot 2\frac{1}{2}$ | 19. $2\frac{1}{3} \cdot 4\frac{1}{2}$ |
| 20. $2\frac{3}{5} \cdot 2\frac{1}{7}$ | 21. $3 \cdot 4\frac{1}{3}$ | 22. $5 \cdot 1\frac{2}{5}$ | 23. $5\frac{1}{6} \cdot 12$ | 24. $3\frac{1}{3} \cdot 6$ |

C **Exponents and Fractions** In Problems 25–36, multiply.

- | | | | |
|--|---|---|---|
| 25. $(\frac{1}{3})^2$ | 26. $(\frac{4}{5})^2$ | 27. $(2\frac{1}{4})^2$ | 28. $(1\frac{1}{4})^2$ |
| 29. a. $\frac{3}{4} \times \frac{8}{9} \times \frac{1}{5}$ | 30. a. $\frac{4}{5} \times 2\frac{1}{2} \times 3$ | 31. $(\frac{2}{3})^2 \cdot \frac{3}{4}$ | 32. $(\frac{4}{5})^2 \cdot \frac{7}{8}$ |
| | b. $\frac{5}{12} \times \frac{6}{7} \times \frac{7}{5}$ | b. $\frac{3}{8} \times 2\frac{1}{3} \times 4$ | |
| 33. $\frac{14}{27} \cdot (\frac{3}{7})^2$ | 34. $\frac{5}{12} \cdot (\frac{6}{5})^2$ | 35. $(\frac{2}{3})^3$ | 36. $(\frac{3}{5})^3$ |

D **Division of Fractions** In Problems 37–48, divide (reduce answers to lowest terms).

- | | | | |
|-------------------------------------|-------------------------------------|-------------------------------------|-------------------------------------|
| 37. $5 \div \frac{2}{3}$ | 38. $7 \div \frac{3}{5}$ | 39. $\frac{4}{5} \div 6$ | 40. $\frac{3}{4} \div 9$ |
| 41. $\frac{2}{3} \div \frac{6}{7}$ | 42. $\frac{3}{5} \div \frac{9}{10}$ | 43. $\frac{4}{5} \div \frac{8}{15}$ | 44. $\frac{3}{7} \div \frac{9}{14}$ |
| 45. $\frac{2}{3} \div \frac{5}{12}$ | 46. $\frac{1}{2} \div \frac{3}{4}$ | 47. $\frac{3}{4} \div \frac{3}{4}$ | 48. $\frac{9}{10} \div \frac{3}{5}$ |

E **Division with Mixed Numbers** In Problems 49–60, divide (reduce answers to lowest terms).

- | | | | |
|--------------------------------------|---------------------------------------|---------------------------------------|--|
| 49. $\frac{3}{5} \div 1\frac{1}{2}$ | 50. $\frac{5}{8} \div 3\frac{1}{3}$ | 51. $3\frac{3}{4} \div \frac{3}{8}$ | 52. $1\frac{1}{5} \div \frac{3}{5}$ |
| 53. $6\frac{1}{2} \div 2\frac{1}{2}$ | 54. $1\frac{5}{8} \div 2\frac{7}{8}$ | 55. $3\frac{1}{8} \div 1\frac{1}{3}$ | 56. $2\frac{1}{2} \div 6\frac{1}{4}$ |
| 57. $3\frac{1}{8} \div 3\frac{1}{8}$ | 58. $10\frac{1}{2} \div 2\frac{1}{3}$ | 59. $1\frac{2}{3} \div 13\frac{3}{4}$ | 60. $4\frac{7}{10} \div 4\frac{7}{10}$ |

F **G** **Applications Involving Multiplying and Dividing Fractions**

61. *Area of pasture* A farm has an area of $\frac{2}{3}$ square mile and $\frac{3}{7}$ of the land is pasture. What area of the farm is pasture in square miles?
62. *Meatball recipe* A recipe for making meatballs to serve 100 people calls for 75 pounds of meat. Charlie Chef made $\frac{2}{3}$ of this recipe.
- How many pounds of beef did he use?
 - About how many people will $\frac{2}{3}$ of the recipe serve?
63. *Number of attendees* Rosa invited 90 people to a party and $\frac{4}{5}$ of them came. How many people came to the party?
64. *Floating in space* Lt. Col. Aleksey Arkhipovich Leonov was the first person to leave an artificial satellite during orbit. He was in space for 20 minutes, and $\frac{3}{5}$ of this time he “floated” at the end of a line. How long did he float in space?
65. *Rain in Prince George* In Prince George it rains or snows on an average of $\frac{8}{15}$ of the days in November. How many days is that?
66. *Weight of the Lunar Rover on the moon* The weight of an object on the moon is $\frac{1}{6}$ of its weight on earth. How much did the Lunar Rover, weighing 450 pounds on earth, weigh on the moon?

- 67. Screw penetration** On each turn a screw goes $\frac{3}{16}$ of an inch into the wood. How many turns are needed to make it go in $1\frac{1}{2}$ inches?
- 69. Making vests** Pete has $10\frac{1}{2}$ yards of material. How many vests can he make if each one takes $\frac{5}{8}$ yard of material?
- 71. Unit conversions** One rod equals $16\frac{1}{2}$ feet. How many feet is 40 rods?
- 73. Unit conversions** In the Old Testament, there is a unit of measurement called an *omer*. An omer is $2\frac{1}{5}$ liters. How many liters are in 5 omers?
- 74. Unit conversions** In the Old Testament, there is a unit of weight called a *shekel*. A shekel is $11\frac{1}{5}$ grams. How many grams are in 10 shekels?
- 68. Wallpaper** One sheet of wallpaper covers $4\frac{1}{2}$ feet of wall. How many sheets are needed to cover $24\frac{3}{4}$ feet of wall?
- 70. Recipes** A recipe calls for $3\frac{1}{2}$ cups of sugar. How many portions can be made with 98 cups of sugar?
- 72. Unit conversions** Many horse races are 7 furlongs. If 40 rods is a furlong:
- How many rods are in 7 furlongs?
 - If one rod is $16\frac{1}{2}$ feet, how many feet are in a furlong?
 - How many feet are in a 7-furlong race?
- 75. Unit conversions** A gallon of gasoline weighs $6\frac{1}{5}$ pounds. If the content of your gas tank weighs $80\frac{3}{5}$ pounds, how many gallons of gasoline does the tank contain?

The following information will be used in Problems 76–80.

How many uses are in each Aquafresh® tube or pump?

Using 1 to 1.2 grams of toothpaste on the brush (numbers are approximate)

PUMPS	4.3 oz	90 brushings
	4.6 oz	110 brushings
	6.0 oz	140 brushings
	6.4 oz	160 brushings
TUBES	1.4 oz	37 brushings
	2.7 oz	73 brushings
	4.3 oz	100 brushings
	4.6 oz	120 brushings
	6.0 oz	150 brushings
	6.4 oz	170 brushings
	8.2 oz	220 brushings

Toothpaste The number of uses (brushings) in each Aquafresh tube or pump is shown. Find the grams of toothpaste per brushing.

Scales on maps The scale on a certain map is 1 inch = 36 miles. If the distance from Indianapolis to Dayton on the map is $2\frac{1}{4}$ inches, the approximate distance is $36 \times 2\frac{1}{4} = 36 \times \frac{9}{4} = 81$ miles.

- 76.** 90 brushings in the 120-gram pump
- 77.** 160 brushings in the 180-gram pump
- 78.** 37 brushings in the 40-gram tube
- 79.** 120 brushings in the 130-gram tube
- 80.** 220 brushings in the 230-gram tube
- 81.** Find the approximate distance from Indianapolis to Cincinnati, a distance of $2\frac{2}{3}$ inches on the map.
- 82.** Find the approximate distance from Indianapolis to Terre Haute, a distance of $2\frac{1}{4}$ inches on the map.
- 83.** Find the approximate distance from Indianapolis to Chicago, a distance of $4\frac{2}{3}$ inches on the map.
- 84.** If the approximate distance between two cities is 108 miles, what is the distance on the map?
- 85.** If the approximate distance between Indianapolis and Detroit is 240 miles, what is the distance on the map?
- 86.** If the approximate distance between Indianapolis and Cleveland is 279 miles, what is the distance on the map?

Area In Problems 87–91, find the area of the envelope.

- 87.** A-2 size measuring $4\frac{3}{8}$ inches by $5\frac{3}{4}$ inches.
- 88.** A-7 size measuring $5\frac{1}{4}$ inches by $7\frac{1}{4}$ inches.
- 89.** Business size 10 measuring $4\frac{1}{8}$ inches by $9\frac{1}{2}$ inches.
- 90.** A U.S. postal envelope measuring 5 inches by $3\frac{1}{2}$ inches.
- 91.** Maximum size international envelope is $9\frac{1}{4}$ inches by $4\frac{2}{3}$ inches.
- 92. Area** The width of the screen is $13\frac{2}{5}$ inches and the height is $9\frac{1}{2}$ inches. What is its area?



93. *Area* The width of the screen is $10\frac{1}{2}$ inches and the height is $12\frac{4}{5}$ inches. What is its area?



94. *Area* The dimensions of the Palm™ organizer are $3\frac{1}{10}$ inches by $4\frac{1}{2}$ inches. What is its area?



95. *Area* The area of a room is $15\frac{3}{4}$ square yards. If the room is $3\frac{1}{2}$ yards wide, how long is it?

96. *Area* A remodeling job calls for $65\frac{1}{2}$ square yards of carpet. How many remodeling jobs could you do with 655 square yards of carpet?

>>> Applications: Green Math

Converting sunshine into electricity by using solar panels will actually cost you more than burning fossil fuels, but there is hope. Grants and tax incentives are available to make the process more cost effective. To read more about this go to <http://tinyurl.com/ck8n62>.

Area and cost of solar panels. In Problems 97–100, find the **area** of the panel. The approximate cost of each panel is given in parentheses (prices vary).

97. 60-watt panel, 27 inches by $30\frac{1}{8}$ inches. (\$350)



Source: <http://www.solarhome.org/60wattframedsolarpanl.aspx>.

98. 50-watt panel, 28 inches by $21\frac{7}{8}$ inches. (\$420)



Source: <http://www.solarhome.org/aeesolaroff-gridsolarmoduleae-50et.aspx>.

99. 60-watt panel, $31\frac{1}{8}$ inches \times $21\frac{1}{8}$ inches. (\$456)

100. 40-watt panel, $25\frac{13}{16}$ inches by $21\frac{1}{8}$ inches. (\$310)

>>> Using Your Knowledge

THE WIZARD OF ID

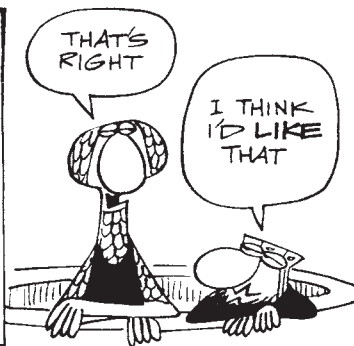

by Brant parker and Johnny hart



By permission of John L. Hart FLP, and Creators Syndicate, Inc.

Scale model A scale drawing or scale model is used to represent an object that is too large or small to be drawn actual size. Pictures in dictionaries show things to scale. For example, the picture of a bird may be $1\frac{1}{4}$ inches long. Actually the bird is $3\frac{1}{2}$ times as long. Thus, the bird is really

$$3\frac{1}{2} \times 1\frac{1}{4} = \frac{7}{2} \times \frac{5}{4} = \frac{35}{8} = 4\frac{3}{8} \text{ inches long}$$

- 101. Blueprints** A landscape plan shows a flower bed $6\frac{1}{2}$ inches wide. If the scale on the plan is **1 in. = 4 ft**, what is the width of the actual flower bed?
- 102. Blueprints** A set of drawings for an office building shows a conference room $7\frac{3}{4}$ inches long. If the scale is **1 in. = 6 ft**, what is the actual length of the conference room?
- 103. Scale Model** An illustration of a honeybee is $4\frac{1}{2}$ centimeters long. If the scale is **1 cm = $\frac{1}{4}$ cm**, what is the actual size of the honeybee?
- 104.** The picture of a bird in a dictionary is $1\frac{1}{2}$ inches long. The bird is actually $4\frac{1}{2}$ times as long. How long is the bird?
- 105.** A bluebird is pictured with a length of $1\frac{1}{4}$ inches. The actual length is $2\frac{1}{2}$ times that of the picture. What is the actual length of the bird?

>>> Write On

- 106.** Write the procedure you use to multiply two fractions.
- 107.** Write the procedure you use to multiply a fraction by 1.
- 108.** Write the procedure you use to multiply a whole number by a fraction.
- 109.** Write the procedure you use to divide one fraction by another fraction.
- 110.** Write the procedure you use to divide a fraction by a nonzero whole number.

>>> Concept Checker

Fill in the blank(s) with the correct word(s), phrase, or mathematical statement.

111. $\frac{a}{b} \cdot \frac{c}{d} =$ _____

$$\frac{a \cdot b}{c \cdot d}$$

112. $\frac{a}{b} \div \frac{c}{d} =$ _____

$$\frac{a \cdot d}{b \cdot c}$$

$$\frac{a \cdot c}{b \cdot d}$$

>>> Mastery Test

Marinade for Bello Burgers:

- 1/4 cup balsamic vinegar
- 1/4 cup soy sauce
- 1/4 cup olive oil
- 3 cloves garlic, minced

- 113.** The recipe for four servings of the marinade sauce used for Bello Burgers is above. Suppose you want to serve eight persons instead of four. How much balsamic vinegar do you need for the updated recipe?
Source: About.com.
- 114.** Multiply: $\frac{3}{5} \cdot \frac{2}{3}$
- 115.** Multiply: $5 \cdot \frac{3}{4}$
- 116.** Find: $\left(\frac{3}{4}\right)^3$
- 117.** Find: $\left(\frac{3}{4}\right)^2 \cdot \left(1\frac{1}{2}\right)$
- 118.** Divide: $\frac{3}{5} \div \frac{2}{3}$
- 119.** Divide: $1\frac{3}{5} \div \frac{2}{5}$
- 120.** Divide: $\frac{8}{5} \div 2\frac{2}{3}$
- 121.** Find the area of a room that measures $3\frac{1}{3}$ yards by $4\frac{2}{3}$ yards.

>>> Skill Checker

Write as a product of primes using exponents.

122. 84

123. 128

124. 72

125. 180

126. 105

127. 900

2.4

The Least Common Multiple (LCM)

▶ Objectives

You should be able to:

- A** > Find the Least Common Multiple (LCM) of two numbers.
- B** > Find the Lowest Common Denominator (LCD) of two fractions and write them using the LCD as the denominator.
- C** > Compare two fractions.
- D** > Solve applications involving LCD.

▶ To Succeed, Review How To . . .

1. Write a number as a product of primes using exponents. (pp. 77–78)
2. Write a fraction as an equivalent one with a specified numerator or denominator. (pp. 125–127)

▶ Getting Started

Planetary Alignments

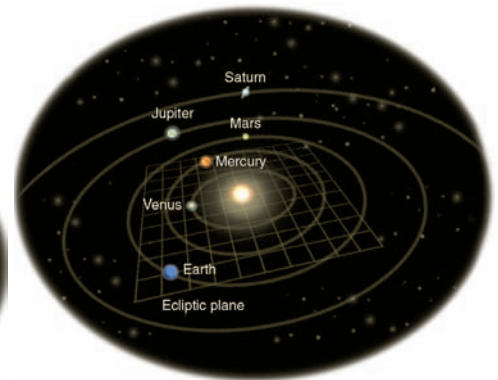
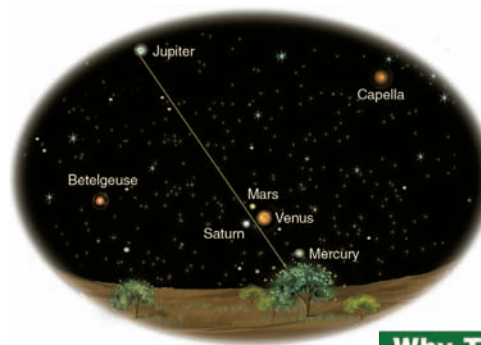

Why They Line Up

When: Monday, May 6

On May 6, Saturn, Mars, Venus, and Mercury fall into an almost straight line with Earth. Because the three dimensions of space are compressed into two when we view the night sky, these four planets appear to be at almost the same point in the sky. This “dimensional compression” also explains why all the planets stay close to the ecliptic line that cuts across the night sky. This line is really a plane in three dimensions, and the orbits of all planets lie pretty much along this plane.

On May 5, 2000, and again on May 6, 2002, there was an unusual alignment of the planets Mercury, Venus, Mars, Jupiter, and Saturn as shown on the left, with their orbits shown on the right. When will this unusual alignment happen again? Astronomers say in 2040, 2060, and 2100. We will study the techniques for verifying this, but for now let us concentrate on Jupiter and Saturn. When will they line up again? It takes Jupiter 12 years to go around the sun once but Saturn takes 30 years! Let us look at the time (in years) it takes each of the planets to go around the sun 1, 2, 3, 4, and 5 orbits.

	1 orbit	2 orbits	3 orbits	4 orbits	5 orbits
Jupiter	12	24	36	48	60
Saturn	30	60	90	120	150

As you can see, after 60 years Jupiter would have made 5 orbits and Saturn 2 so it will take 60 years for Jupiter and Saturn to line up again! The number 60 is the **least common multiple (LCM)** of 12 and 30.

A > Finding the LCM of Two Numbers

The **least common multiple (LCM)** of two natural numbers is the *smallest* number that is a *multiple* of both numbers.

To find the LCM of two numbers, make a *list* of the multiples of each number, compare the lists, and find the **first** multiple that appears on both lists: that number is the **LCM** of the two numbers.

EXAMPLE 1 Finding the LCM of two numbers

Find the LCM of 8 and 12.

SOLUTION 1 Write the multiples of 8 and of 12 and select the **first** multiple that appears on both lists.

Multiples of 8	8	16	24	32	40
Multiples of 12	12	24	36	48	60

Since the **first** multiple appearing on both lists is 24, the LCM of 8 and 12 is **24**.

PROBLEM 1

Find the LCM of 6 and 8.

EXAMPLE 2 Finding the LCM of two numbers

Find the LCM of 6 and 10.

SOLUTION 2

Multiples of 6	6	12	18	24	30	36
Multiples of 10	10	20	30	40	50	60

The **first** multiple appearing on both lists is 30, so the LCM of 6 and 10 is **30**.

PROBLEM 2

Find the LCM of 10 and 12.

You can save some time when finding the LCM of two numbers if you select the **larger** of the two numbers and list its multiples until you get a number that is a multiple of the smaller number. Thus, when finding the LCM of 6 and 10, select 10 (the larger of 6 and 10) and list the multiples of 10 until you get a multiple of 6 (the smaller). The multiples of 10 are 10, 20, **30 (Stop!)**. Since 30 is a multiple of 6, the LCM of 6 and 10 is **30** as before.

EXAMPLE 3 Finding the LCM of two numbers

Find the LCM of 9 and 12.

SOLUTION 3 Using our short cut, list the multiples of 12 (the **larger** of the two given numbers) until you find a multiple of 9.

Multiples of 12	12	24	36 (Stop!)
-----------------	----	----	------------

Since **36** is a multiple of 9, the LCM of 9 and 12 is **36**.

PROBLEM 3

Find the LCM of 18 and 12.

The short cut we have used can save us even more time when the *larger* of the two given numbers is already a *multiple* of the smaller one. For example, if you are finding the LCM of 7 and 21 and follow the procedure, you list the multiples of 21, the larger number, and as soon as you do you realize that the very first multiple you list, the **21** is also a multiple of 7. Thus, the LCM of 7 and 21 is **21**. Similarly, the LCM of 10 and 30 is **30** and the LCM of 11 and 55 is **55**. This is because 30 is a multiple of 10 and 55 is a multiple of 11.

EXAMPLE 4 Finding the LCM of two numbers

Find the LCM of 15 and 45.

SOLUTION 4 Since 45 is a multiple of 15, the LCM of 15 and 45 is **45**.

PROBLEM 4

Find the LCM of 13 and 39.

Answers to PROBLEMS

1. 24 2. 60 3. 36 4. 39

B > Writing Fractions with the Lowest Common Denominator (LCD)

The graph shows the approximate expenses at a community college. The greatest expense is **food**, which is $\frac{3}{10}$ of the total. The next expense is **tuition**, $\frac{1}{4}$ of the total. How much more is the food than the tuition? We can not exactly tell right now, because the whole is not divided into equal parts; that is, parts that are **common** to the whole. If we divide the whole into **20** equal parts, we can easily compare tuition and food. **Tuition** is $\frac{5}{20}$ and **food** is $\frac{6}{20}$, so the expenses for food are more than for tuition. But, where did the **20** come from? Remember **least common multiples**?

Expenses at a Community College

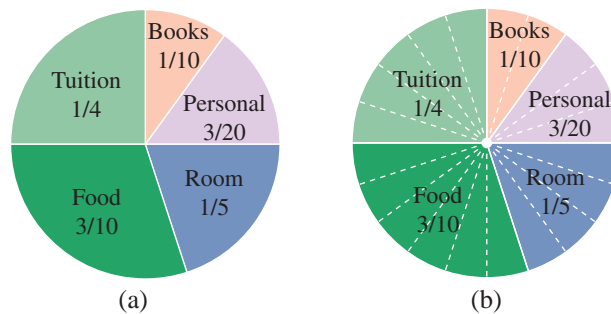

20 is the *least common multiple* of **10** and **4**, the denominators for the tuition portion ($\frac{1}{4}$) and the food portion ($\frac{3}{10}$). In general, the **smallest** denominator that allows us to compare fractions directly—that is, having the same denominator—is the **lowest common denominator** (LCD) of the fractions. This number is also the **least common multiple** (LCM) of the denominators.

EXAMPLE 5 Writing fractions with the LCD as denominator

Personal and room expenses at a community college are $\frac{3}{20}$ and $\frac{1}{5}$ of the total expenses respectively. (See the diagram.)

- Find the LCD of $\frac{3}{20}$ and $\frac{1}{5}$.
- Write $\frac{3}{20}$ and $\frac{1}{5}$ using the LCD as the denominator.

SOLUTION 5

- Since **20** is a multiple of 5, the LCD of $\frac{3}{20}$ and $\frac{1}{5}$ is **20**.
- $\frac{3}{20}$ is already written using the LCD **20** as denominator.

To write $\frac{1}{5}$ with **20** as denominator, we have to multiply the denominator 5 (as well as the numerator 1), by **4** like this:

$$\frac{1}{5} = \frac{1 \cdot 4}{5 \cdot 4} = \frac{4}{20}$$

PROBLEM 5

Find the LCD of

- $\frac{3}{10}$ and $\frac{1}{6}$.
- Write $\frac{3}{10}$ and $\frac{1}{6}$ with the LCD as denominator.

EXAMPLE 6 Finding the LCD using multiples

- Find the LCD of $\frac{3}{8}$ and $\frac{2}{5}$ using multiples.
- Write $\frac{3}{8}$ and $\frac{2}{5}$ using the LCD as denominator.

SOLUTION 6

- The multiples of 8 (the larger of the two denominators) are

8 16 24 32 40 **Stop!** 40 is a multiple of 5.

The LCD of $\frac{3}{8}$ and $\frac{2}{5}$ is **40**.

PROBLEM 6

- Find the LCD of $\frac{3}{7}$ and $\frac{4}{5}$ using multiples.
- Write $\frac{3}{7}$ and $\frac{4}{5}$ using the LCD as denominator.

(continued)

Answers to PROBLEMS

5. a. 30 b. $\frac{9}{30}, \frac{5}{30}$ 6. a. 35 b. $\frac{15}{35}, \frac{28}{35}$

- b. To write $\frac{3}{8}$ with a denominator of **40** we have to multiply the denominator 8 (as well as the numerator 3) by **5**.

$$\text{We have: } \frac{3}{8} = \frac{3 \cdot 5}{8 \cdot 5} = \frac{15}{40}$$

$$\text{Similarly, } \frac{2}{5} = \frac{2 \cdot 8}{5 \cdot 8} = \frac{16}{40}$$

Suppose you want to find the LCD of $\frac{1}{30}$ and $\frac{1}{54}$. To list the multiples of 54 is too time-consuming. Here is a second way to find the LCD of two fractions. (We are finding the LCD of $\frac{1}{30}$ and $\frac{1}{54}$.)

We first write 30 and 54 as products of primes.

$$\text{Divide by 2. } \rightarrow 2 \overline{)30}$$

$$\text{Divide by 3. } \rightarrow 3 \overline{)15}$$

$$\text{Divide by 5. } \rightarrow 5 \overline{)5}$$

$$\text{Stop, we have 1. } \quad 1$$

$$\text{Divide by 2. } \rightarrow 2 \overline{)54}$$

$$\text{Divide by 3. } \rightarrow 3 \overline{)27}$$

$$\text{Divide by 3. } \rightarrow 3 \overline{)9}$$

$$\text{Divide by 3. } \rightarrow 3 \overline{)3}$$

$$\text{Stop, we have 1. } \quad 1$$

$$\text{Thus, } 30 = 2 \cdot 3 \cdot 5$$

$$\text{Thus, } 54 = 2 \cdot 3 \cdot 3 \cdot 3 = 2 \cdot 3^3$$

It will help if you place the same primes vertically in a column.

$$\begin{array}{c}
 \text{all the 2's here} \\
 \text{all the 3's here} \\
 \text{all the 5's here} \\
 \begin{array}{r}
 30 = 2 \cdot 3 \cdot 5 \\
 54 = 2 \cdot 3^3
 \end{array}
 \end{array}$$

To find the LCD we must include 2 from the first column, 3^3 from the second column, and 5 from the third column. Thus, the least common denominator is $2 \cdot 3^3 \cdot 5 = 270$. Here is the procedure.

PROCEDURE TO FIND THE LCD OF FRACTIONS USING PRIMES

1. Write each denominator as a product of primes using exponents.
2. Select the *highest* power of each prime which occurs in any factorization.
3. The product of the factors selected in step 2 is the LCD.

Some students prefer another method for finding the LCD. It works like this:

FINDING LCDs: ALTERNATE METHOD USING DIVISION

1. Write the denominators in a horizontal row and divide each number by a *prime* common to two or more of the numbers. (If any of the other numbers is *not* divisible by this prime, *circle* the number and carry it to the next line.)
2. Continue this process until *no prime* divides two of the quotients.
3. The LCD is the *product* of the primes and the numbers in the final line.

- Step 1.** Divide by 2.
Divide by 3
(the next prime).

$$\begin{array}{r}
 2 \overline{) 30 \quad 54} \\
 3 \overline{) 15 \quad 27} \\
 \quad 5 \quad 9
 \end{array}$$

Step 2. No prime divides 5 and 9.

Step 3. The LCD is

$$2 \cdot 3 \cdot 5 \cdot 9 = 270$$

Note that in either case (using primes or using division), the LCD is 270. We shall use both methods when finding LCDs.

EXAMPLE 7 Finding the LCD of fractions

Find the LCD of $\frac{1}{60}$ and $\frac{1}{18}$.

SOLUTION 7

METHOD 1

Step 1. Write 60 and 18 as products of primes.

$$\begin{array}{l} 60 = |2^2| \cdot |3| \cdot |5| \\ 18 = |2| \cdot |3^2| \end{array}$$

Step 2. Select each prime to the highest power to which it occurs (2^2 , 3^2 , and 5).

Step 3. The product of the factors from step 2 is the LCD:

$$2^2 \cdot 3^2 \cdot 5 = 180 \text{ is the LCD}$$

METHOD 2

Step 1. Write the denominators in a row and divide by a prime common to two of the numbers.

$$\begin{array}{r|rr} 2 & 60 & 18 \\ \hline 3 & 30 & 9 \\ \hline & 10 & 3 \end{array}$$

Step 2. Continue until no prime divides both quotients (no prime divides 10 and 3).

Step 3. The product of the primes and the numbers in the final line is the LCD:

$$2 \cdot 3 \cdot 10 \cdot 3 = 180 \text{ is the LCD}$$

METHOD 3

You can also find the LCD by using multiples. The multiples of 60 are 60, 120, and 180, which is a multiple of 18, so the LCD is still 180.

PROBLEM 7

Find the LCD of $\frac{1}{40}$ and $\frac{5}{12}$.

The methods we have studied (multiples, primes, and division) can be used to find the *lowest common denominator* (LCD) of more than two fractions. For example, to find the LCD of $\frac{1}{10}$, $\frac{1}{12}$, and $\frac{1}{8}$ we use the short cut of Example 3 and list the multiples of the **largest** denominator, which is 12, until we get a number that is a multiple of 10 and 8.

The multiples of 12 are 12 24 36 48 60 72 84 96 108 120 (**Stop!**). Since 120 is a multiple of 10 and also a multiple of 8, the LCD of $\frac{1}{10}$, $\frac{1}{12}$, and $\frac{1}{8}$ is **120**.

Is there an easier way? Try the division method:

Step 1. Divide by 2.

$$\begin{array}{r|rrr} 2 & 10 & 12 & 8 \\ \hline 2 & 5 & 6 & 4 \\ \hline & 5 & 3 & 2 \end{array}$$

Divide by 2.

Step 2. Remember to circle the 5 because it is not divisible by 2 and carry it to the next line.

Step 3. The LCD is $2 \cdot 2 \cdot 5 \cdot 3 \cdot 2 = 120$ as before.

Answers to PROBLEMS

7. 120

EXAMPLE 8 Finding the LCD of three fractions

Find the LCD of $\frac{1}{6}$, $\frac{1}{10}$, and $\frac{1}{9}$.

SOLUTION 8 In this case, it is easier to use the division method.

Step 1. Divide by 2.

2	6	10	9
3	3	5	9
1	5	3	

Divide by 3.

3	3	5	9
1	5	3	

Step 2. Remember to circle the 9 and 5 and carry them to the next line.

Step 3. The LCD is $2 \cdot 3 \cdot 1 \cdot 5 \cdot 3 = 90$.

PROBLEM 8

Find the LCD of $\frac{1}{8}$, $\frac{1}{12}$, and $\frac{1}{14}$.

C > Comparing Fractions: Order

The LCD can be used to compare fractions. Here are the ingredients for the recipes of sweet rolls and buttermilk dough.

Sweet Rolls

- 3 packages of yeast
- $\frac{3}{4}$ cup water
- $\frac{3}{4}$ cup milk
- $\frac{1}{2}$ cup sugar
- $1\frac{1}{2}$ teaspoon salt
- $\frac{1}{2}$ cup butter
- 2 eggs
- $5\frac{1}{2}$ cups flour

Buttermilk Doughnuts

- 2 tablespoons shortening
- $\frac{3}{4}$ cup sugar
- 2 eggs
- 4 cups flour
- 2 teaspoons baking powder
- $\frac{1}{2}$ teaspoon cinnamon
- 1 cup buttermilk
- $\frac{1}{2}$ teaspoon salt

To find which recipe uses more salt is easy: the sweet rolls! You can convince yourself by writing $1\frac{1}{2}$ as $\frac{3}{2}$ and compare $\frac{3}{2}$ and $\frac{1}{2}$, two fractions with the same denominator. Here is the rule:

COMPARING FRACTIONS: SAME DENOMINATOR

To compare two fractions with the same denominator, compare the numerators. The one with the greater numerator is greater.



You can see that $\frac{3}{2}$ is greater than $\frac{1}{2}$.

Since $\frac{3}{2}$ has the numerator 3, which is greater than the numerator 1 in $\frac{1}{2}$ the $\frac{3}{2}$ is greater than $\frac{1}{2}$, and thus the sweet rolls use more salt.

Can you tell which recipe uses more sugar? Since $\frac{1}{2}$ and $\frac{3}{4}$ do **not** have the same denominator, we write both fractions as equivalent ones with the LCD as the denominator. Because 4 is a multiple of 2, the LCD of $\frac{1}{2}$ and $\frac{3}{4}$ is **4**, so we write $\frac{1}{2} = \frac{1 \cdot 2}{2 \cdot 2} = \frac{2}{4}$.

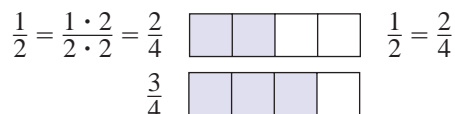

Since the numerator in $\frac{3}{4}$, the 3, is **greater** than the numerator in $\frac{2}{4}$, the 2, we write $\frac{3}{4} > \frac{2}{4} = \frac{1}{2}$.

This means that the buttermilk dough has more sugar. Here is the rule to compare fractions with different denominators.

COMPARING FRACTIONS: DIFFERENT DENOMINATORS

To compare two fractions with different denominators, write both fractions with the LCD as their denominators. The fraction with the **greater** (larger) numerator is **greater** (larger).

EXAMPLE 9 Comparing fractions

Fill in the blank with $<$ or $>$ to make the resulting inequality true.

a. $\frac{5}{7}$ _____ $\frac{4}{7}$

b. $\frac{3}{5}$ _____ $\frac{4}{7}$

SOLUTION 9

- a. The two fractions have the same denominator, but $\frac{5}{7}$ has a greater numerator than $\frac{4}{7}$. Thus $\frac{5}{7}$ is greater than $\frac{4}{7}$, that is, $\frac{5}{7} > \frac{4}{7}$.
- b. We first have to write $\frac{3}{5}$ and $\frac{4}{7}$ as equivalent fractions with the LCD 35 as denominator.

$$\frac{3}{5} = \frac{3 \times 7}{5 \times 7} = \frac{3 \times 7}{5 \times 7} = \frac{21}{35}$$

$$\frac{4}{7} = \frac{4 \times 5}{7 \times 5} = \frac{4 \times 5}{7 \times 5} = \frac{20}{35}$$

Since $\frac{21}{35} > \frac{20}{35}$,

$$\frac{3}{5} > \frac{4}{7} \quad \left(\frac{3}{5} \text{ is greater than } \frac{4}{7}\right)$$

PROBLEM 9

Fill in the blank with $<$ or $>$ to make the resulting inequality true.

a. $\frac{3}{17}$ _____ $\frac{2}{17}$

b. $\frac{1}{5}$ _____ $\frac{2}{9}$

D > Applications Involving LCM and LCD

There is a lot of talk about recycling and saving the Earth. How are we doing? The chart tells us! Of all our solid waste, $\frac{1}{3}$ is recovered for recycling (that is good), $\frac{3}{25}$ is burned to create energy (somewhat good), and $\frac{27}{50}$ is simply discarded (not so good).

GREEN MATH

EXAMPLE 10 Managing MSW using LCD

- a. Find the LCD of $\frac{1}{3}$ and $\frac{3}{25}$.
- b. Write $\frac{1}{3}$ and $\frac{3}{25}$ using the LCD as the denominator.

SOLUTION 10

- a. We find the multiples of the larger number (25) until we get a multiple that is divisible by 3. That would be the LCD. Multiples of 25: 25 50 **75** (Stop!) Since 75 is divisible by 3, **75** is the LCD of 3 and 25.
- b. We have to write $\frac{1}{3}$ and $\frac{3}{25}$ using the LCD 75 as denominator.

$$\frac{1}{3} = \frac{1 \cdot 25}{3 \cdot 25} = \frac{25}{75} \quad \text{and} \quad \frac{3}{25} = \frac{3 \cdot 3}{25 \cdot 3} = \frac{9}{75}$$

Thus, $\frac{1}{3}$ and $\frac{3}{25}$ are both written with a denominator of 75.

Source: <http://www.epa.gov/osw/nonhaz/municipal/pubs/msw07-rpt.pdf>.

PROBLEM 10

- a. Find the LCD of $\frac{1}{3}$ and $\frac{27}{50}$.
- b. Write $\frac{1}{3}$ and $\frac{27}{50}$ using the LCD as denominator.

Management of MSW in the United States

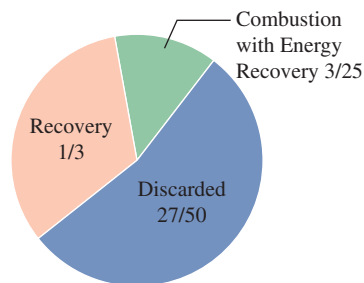

Answers to PROBLEMS

9. a. $>$ b. $<$ 10. a. 150 b. $\frac{50}{150}$ and $\frac{81}{150}$



> Practice Problems > Self-Tests
> Media-rich eBooks > e-Professors > Videos

> Exercises 2.4

< A > Finding the LCM of Two Numbers In Problems 1–10, find the LCM of the numbers by listing the multiples.

- | | | |
|--------------------|---------------|-------------------|
| 1. 8 and 10 | 2. 6 and 10 | 3. 16 and 24 |
| 4. 21 and 28 | 5. 9 and 18 | 6. 30 and 60 |
| 7. 14 and 21 | 8. 80 and 120 | 9. 30, 15, and 60 |
| 10. 15, 20, and 30 | | |

< B > Writing Fractions with the Lowest Common Denominator (LCD) In Problems 11–20, find the LCD of the fractions using multiples and write the fractions with the LCD as denominator.

- | | | | |
|--|--|---|---|
| 11. $\frac{1}{3}$ and $\frac{1}{6}$ | 12. $\frac{2}{5}$ and $\frac{1}{15}$ | 13. $\frac{1}{21}$ and $\frac{1}{7}$ | 14. $\frac{2}{9}$ and $\frac{1}{3}$ |
| 15. $\frac{3}{4}$ and $\frac{1}{10}$ | 16. $\frac{7}{10}$ and $\frac{4}{15}$ | 17. $\frac{1}{6}$, $\frac{1}{12}$, and $\frac{1}{24}$ | 18. $\frac{7}{15}$, $\frac{3}{10}$, and $\frac{1}{6}$ |
| 19. $\frac{3}{5}$, $\frac{5}{8}$, and $\frac{7}{20}$ | 20. $\frac{2}{9}$, $\frac{7}{12}$, and $\frac{11}{24}$ | | |

In Problems 21–30, find the LCD using the decomposition of primes or the division method and write the fractions with the LCD as denominator.

- | | | | |
|--|--|---|---|
| 21. $\frac{1}{18}$ and $\frac{1}{24}$ | 22. $\frac{3}{15}$ and $\frac{2}{45}$ | 23. $\frac{1}{32}$ and $\frac{1}{80}$ | 24. $\frac{2}{9}$ and $\frac{1}{12}$ |
| 25. $\frac{3}{4}$ and $\frac{3}{10}$ | 26. $\frac{7}{20}$ and $\frac{4}{15}$ | 27. $\frac{1}{6}$, $\frac{1}{12}$, and $\frac{1}{24}$ | 28. $\frac{7}{15}$, $\frac{3}{10}$, and $\frac{1}{6}$ |
| 29. $\frac{3}{5}$, $\frac{5}{8}$, and $\frac{7}{20}$ | 30. $\frac{2}{9}$, $\frac{7}{12}$, and $\frac{11}{24}$ | | |

< C > Comparing Fractions: Order In Problems 31–34, find the greater of the two numbers.

- | | | | |
|-----------------------------------|-----------------------------------|-------------------------------------|-----------------------------------|
| 31. $\frac{5}{8}$, $\frac{7}{8}$ | 32. $\frac{5}{9}$, $\frac{7}{9}$ | 33. $\frac{4}{11}$, $\frac{5}{11}$ | 34. $\frac{3}{7}$, $\frac{2}{7}$ |
|-----------------------------------|-----------------------------------|-------------------------------------|-----------------------------------|

In Problems 35–40, fill in the blank with $<$ or $>$ to make the resulting inequality true.

- | | | | | | |
|--|--|--|--|--|--|
| 35. $\frac{2}{3}$ $\underline{\hspace{1cm}}$ $\frac{4}{5}$ | 36. $\frac{5}{8}$ $\underline{\hspace{1cm}}$ $\frac{1}{2}$ | 37. $1\frac{4}{7}$ $\underline{\hspace{1cm}}$ $1\frac{5}{7}$ | 38. $8\frac{3}{4}$ $\underline{\hspace{1cm}}$ $8\frac{7}{8}$ | 39. $11\frac{2}{7}$ $\underline{\hspace{1cm}}$ $11\frac{3}{8}$ | 40. $6\frac{1}{3}$ $\underline{\hspace{1cm}}$ $6\frac{2}{5}$ |
|--|--|--|--|--|--|

>>> Applications

41. *Transportation* Do you use public transportation to go to school? If buses depart every 20 minutes and trains every 30 minutes and you just missed the bus and the train, how long do you have to wait before a bus and a train will be departing for your school at the same time?



42. *Transportation* Trains A, B, and C leave Grand Central Station every 10, 20, or 45 minutes, respectively. If A, B, and C just departed, what is the minimum time you have to wait before all three trains are available at the same time?



Applications: Green Math

43. Farming and urbanization of suitable habitats have reduced the populations of *cicadas*, a type of insect sometimes called “locusts” even though they are unrelated to true locusts. The *dogday* cicadas appear during July and August and have 2 to 5 year cycles. The periodical *cicada* in the photo is a 17-year *magicicada*. The 17 means that this species emerge every 17 years. There is also a 13-year *magicicada*. It is thought that some broods for the 13- and 17-year cicadas may be extinct. If both species of the 13- and 17-year *cicadas* emerge this year, how many years will it be before they emerge together again?



A 17-year cycle *magicicada*

44. *Cicada* Fortunately, cicadas have predators! Suppose predators emerge 3 years from now and you have a 15-year cicada cycle starting right now.

a. In how many years will the cicada face the predators?

b. If you have a 17-year *magicicada* cycle starting now, in how many years will they face the 3-year predators?

46. *Common cold* If in addition to the soup (every 6 hours), the lozenges (every 2 hours), and the aspirin (every 4 hours) you take a 12-hour nasal spray and you start your medications at 12 P.M., in how many hours will you have to take all four medicines again?

Source: <http://walmart.triaddigital.com/>.

48. *Tamales and pastries* The meat used for filling in the tamales and pastries is delivered every 2 days. If all items were fresh today, in how many days will they have fresh tamales (made fresh every 5 days), fresh pastries (made fresh every 4 days) filled with fresh meat (delivered fresh every 2 days)?

49. *Deliveries* The delivery for wraps is every 4 days but the ingredients for the sports supplement come every 3 days. If deliveries were made today, in how many days will fresh wraps and supplements be delivered?

50. *Deliveries* The delivery schedule for the products listed is as follows:

Smoothie: Every 30 days

Wraps: Every 4 days

Protein drinks: Every 5 days

Sports supplements: Every 3 days

If all products were delivered today, in how many days will all four products be delivered again?

45. *Common cold* There is no cure for it, but here are some things you can do.

Grandma was right—chicken soup actually is good for a cold! One serving every 6 hours.

Zinc lozenges could help you get better sooner. One lozenge every 2 hours.

Aspirin, acetaminophen, and ibuprofen to relieve some symptoms: Two tablets every 4 hours.

You start your three medications (soup, lozenges, and aspirin) at 12 P.M. In how many hours will you have to take all three again?

47. *Tamales and pastries* La Cubanita Restaurant prepares fresh tamales every 5 days. Pastries are freshly made every 4 days. Andreas had fresh tamales and pastries today. In how many days will the tamales and pastries be made fresh again?



JJ Smoothy

NOW OPEN

- SMOOTHIES
- WRAPS
- PROTEIN DRINKS
- SPORTS SUPPLEMENTS

Using Your Knowledge

Orbital times The table showing the approximate orbital time for Mars, Jupiter, Saturn, and Uranus will be used in Problems 51–53.

	Mars	Jupiter	Saturn	Uranus
Orbital period (Earth years)	2	12	30	84

51. You remember the planet alignment from the Getting Started? As you can see from the table it takes about 12 years for Jupiter to orbit around the sun once but it takes Saturn 30 years to do so. If Mars takes about 2 years to orbit the sun and the last planetary alignment of Jupiter, Mars, and Saturn was in the year 2000, in what year will the alignment of the three planets happen again?
52. If Jupiter, Uranus, and Mars were aligned today, how many years would it take for them to align again?
53. If Saturn and Uranus were aligned today, how many years will it take for them to align again?

Write On

54. Write in your own words the procedure you use to find the LCM of three numbers by using the division method.
55. Which of the three methods shown in this section will be most efficient to find the LCM of:
- 5, 10, and 20. Why?
 - 32 and 40. Why?
56. Write in your own words the criteria you use to determine which of the three methods to use when finding the LCM of three numbers.
57. Write in your own words what is the relationship between the LCD of several fractions and the LCM of the denominators of the fraction.

Concept Checker

Fill in the blank(s) with the correct word(s), phrase, or mathematical statement.

58. The _____ of two numbers is the **smallest number** that is a **multiple** of both numbers. **denominator**
59. The **LCD of two fractions** is also the _____ of the **denominators** of the **fractions**. **numerators**
60. To **compare** fractions with the **same** denominator, we have to **compare** the _____. **LCD**
61. To **compare** fractions with **different** denominators we have to write both fractions with the _____ as their **denominator**. **LCM**

Mastery Test

62. Fill in the blank with < or > to make the resulting inequality true: $\frac{4}{11}$ _____ $\frac{5}{11}$.
63. Fill in the blank with < or > to make the resulting inequality true: $\frac{3}{11}$ _____ $\frac{1}{4}$.
64. Find the LCM of 12 and 14.
65. Find the LCM of 15 and 45.
66. Find the LCM of 10, 3, and 14.
67. Write fractions equivalent to $\frac{3}{7}$ and $\frac{4}{5}$ using their LCD as denominator.
68. Find the LCD of $\frac{1}{40}$ and $\frac{1}{18}$.
69. Find the LCD of $\frac{1}{6}$, $\frac{1}{20}$, and $\frac{1}{9}$.

>>> Skill Checker

70. Write $\frac{1}{8}$ and $\frac{1}{6}$ with a denominator of 24.
71. Write $\frac{5}{9}$ and $\frac{3}{8}$ with a denominator of 72.
72. Write $\frac{1}{8}$, $\frac{1}{12}$, and $\frac{1}{10}$ with a denominator of 120.

2.5

Addition and Subtraction of Fractions

▶ Objectives

You should be able to:

- A** > Add two fractions having the same denominator.
- B** > Add two fractions with different denominators using the idea of a multiple to find the LCD.
- C** > Use the LCD to add fractions.
- D** > Use the LCD to subtract fractions.
- E** > Find what fraction of a circle graph is represented by a given region.

▶ To Succeed, Review How To . . .

1. Write a number as a product of primes using exponents. (pp. 77–78)
2. Write a mixed number as an improper fraction and vice versa. (p. 117)

▶ Getting Started



The photo shows that 1 quarter plus 2 quarters equals 3 quarters. In symbols we have

$$\frac{1}{4} + \frac{2}{4} = \frac{1+2}{4} = \frac{3}{4}$$

Here is a diagram showing what happens when we add quarters.

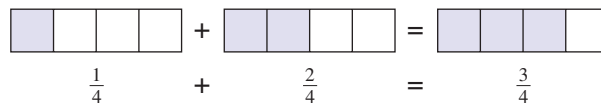

A > Adding Fractions with the Same Denominator

To add fractions with the *same* denominator, *add* the numerators and *keep* the denominator. Here is the rule:

ADDING FRACTIONS WITH THE SAME DENOMINATOR

For any numbers a , b , and c , where $b \neq 0$,

$$\frac{a}{b} + \frac{c}{b} = \frac{a+c}{b}$$

Add numerators a and c , keep the denominator b .

Thus,

$$\frac{1}{5} + \frac{3}{5} = \frac{1+3}{5} = \frac{4}{5}$$

$$\frac{3}{7} + \frac{2}{7} = \frac{3+2}{7} = \frac{5}{7}$$

$$\frac{1}{4} + \frac{5}{4} = \frac{1+5}{4} = \frac{6}{4} = \frac{3}{2}$$

Note that we reduced $\frac{6}{4}$ to $\frac{3}{2}$. When working with fractions (adding, subtracting, multiplying, or dividing them) you should *reduce* your answers if possible.

EXAMPLE 1 Adding fractions with the same denominator

Add.

a. $\frac{2}{5} + \frac{1}{5}$

b. $\frac{4}{9} + \frac{2}{9}$

SOLUTION 1

a. $\frac{2}{5} + \frac{1}{5} = \frac{2+1}{5} = \frac{3}{5}$

b. $\frac{4}{9} + \frac{2}{9} = \frac{4+2}{9} = \frac{6}{9} = \frac{2}{3}$

PROBLEM 1

Add.

a. $\frac{2}{11} + \frac{3}{11}$ b. $\frac{1}{8} + \frac{3}{8}$

B > Adding Fractions with Different Denominators

Now suppose we want to add $\frac{2}{5}$ and $\frac{1}{4}$. Since these two fractions do not have the same denominators, our rule does not work. We have to write $\frac{2}{5}$ and $\frac{1}{4}$ as equivalent fractions with the LCD as denominators so that we can use the rule.

To find the LCD of $\frac{2}{5}$ and $\frac{1}{4}$ look at the multiples of 5 until you find a multiple of 5 that is divisible by 4. The multiples of 5 are

5 10 15 20 (stop!)

20 is a multiple of 4

So the LCD of $\frac{2}{5}$ and $\frac{1}{4}$ is 20. Next, we write $\frac{2}{5}$ and $\frac{1}{4}$ using the LCD 20 as denominator

$$\frac{2 \cdot 4}{5 \cdot 4} = \frac{8}{20} \quad \text{and} \quad \frac{1 \cdot 5}{4 \cdot 5} = \frac{5}{20}$$

Thus, $\frac{8}{20}$ and $\frac{5}{20}$ are fractions equivalent to $\frac{2}{5}$ and $\frac{1}{4}$ and with the LCD as denominator, so they can be added. Thus,

$$\frac{2}{5} + \frac{1}{4} = \frac{2 \cdot 4}{5 \cdot 4} + \frac{1 \cdot 5}{4 \cdot 5} = \frac{8}{20} + \frac{5}{20} = \frac{8+5}{20} = \frac{13}{20}$$

You can also add fractions vertically, like this:

$$\begin{array}{r} \frac{2}{5} = \frac{2 \cdot 4}{5 \cdot 4} = \frac{8}{20} \\ + \frac{1}{4} = + \frac{1 \cdot 5}{4 \cdot 5} = + \frac{5}{20} \\ \hline \frac{13}{20} \end{array}$$

Answers to PROBLEMS

1. a. $\frac{5}{11}$ b. $\frac{4}{8} = \frac{1}{2}$

Adding Fractions with Different Denominators If we wish to add $\frac{3}{4} + \frac{1}{6}$, we first find the LCD of $\frac{3}{4}$ and $\frac{1}{6}$, which is 12, and write $\frac{3}{4}$ and $\frac{1}{6}$ with 12 as the denominator

$$\frac{3}{4} = \frac{3 \cdot 3}{4 \cdot 3} = \frac{9}{12}$$

and

$$\frac{1}{6} = \frac{1 \cdot 2}{6 \cdot 2} = \frac{2}{12}$$

Thus, $\frac{9}{12}$ and $\frac{2}{12}$ are equivalent to $\frac{3}{4}$ and $\frac{1}{6}$, respectively, and have the same denominator. Then

$$\frac{3}{4} + \frac{1}{6} = \frac{9}{12} + \frac{2}{12} = \frac{9+2}{12} = \frac{11}{12}$$

Note that we could have used $\frac{18}{24}$ and $\frac{4}{24}$ as our equivalent fractions with the same denominator. This was not done, however, because the fractions $\frac{9}{12}$ and $\frac{2}{12}$ had lesser denominators. When adding fractions, we *always* try to obtain the **Lowest Common Denominator (LCD)**. Suppose we insisted on using 24 as our denominator:

$$\frac{3}{4} = \frac{3 \cdot 6}{4 \cdot 6} = \frac{18}{24}$$

and

$$\frac{1}{6} = \frac{1 \cdot 4}{6 \cdot 4} = \frac{4}{24}$$

Thus,

$$\begin{aligned} \frac{3}{4} + \frac{1}{6} &= \frac{18}{24} + \frac{4}{24} \\ &= \frac{18+4}{24} = \frac{22}{24} = \frac{11}{12} \end{aligned}$$

Of course, we got the same answer, but it was a lot more work!

Remember, to find the LCD of $\frac{1}{8}$ and $\frac{5}{6}$ list the multiple of 8 (the larger of the two denominators) until you find the first multiple of 6.

Multiples of 8: 8, 16, 24 ← A multiple of 6
(6 goes exactly into 24)

Not a multiple of 6 (6 does not go exactly into 8 or into 16)

Thus, the LCD of $\frac{1}{8}$ and $\frac{5}{6}$ is 24. In general, we can use this procedure:

FINDING THE LCD OF FRACTIONS

Check the multiples of the *greater* denominator until you get a multiple of the smaller denominator.

EXAMPLE 2 Adding fractions with unlike denominators

Add.

$$\frac{1}{8} + \frac{5}{6}$$

SOLUTION 2 The LCD of $\frac{1}{8}$ and $\frac{5}{6}$ is 24 (try the multiples of 8: 8, 16, 24), and $24 = 8 \times 3 = 6 \times 4$. We write

$$\begin{aligned} \frac{1}{8} &= \frac{1 \times 3}{8 \times 3} = \frac{3}{24} \\ \frac{5}{6} &= \frac{5 \times 4}{6 \times 4} = \frac{20}{24} \end{aligned}$$

Thus,

$$\frac{1}{8} + \frac{5}{6} = \frac{3}{24} + \frac{20}{24} = \frac{23}{24}$$

PROBLEM 2

Add.

$$\frac{3}{8} + \frac{1}{6}$$

Answers to PROBLEMS

2. $\frac{13}{24}$

EXAMPLE 3 Adding fractions with unlike denominators

Add.

$$\frac{7}{4} + \frac{1}{15}$$

SOLUTION 3 We first find the LCD. The multiples of 15 (the larger of the two denominators) are

$$\underline{15, 30, 45, 60} \leftarrow \text{Multiple of 4 (4 goes into it)}$$

Not multiples of 4

Thus, the LCD of $\frac{7}{4}$ and $\frac{1}{15}$ is 60, and $\frac{7}{4} = \frac{105}{60}$ and $\frac{1}{15} = \frac{4}{60}$. So,

$$\frac{7}{4} + \frac{1}{15} = \frac{105}{60} + \frac{4}{60} = \frac{109}{60} \quad \text{or} \quad 1\frac{49}{60}$$

PROBLEM 3

Add.

$$\frac{3}{4} + \frac{5}{9}$$

Here is the procedure we have used to add fractions with different denominators:

ADDING FRACTIONS WITH DIFFERENT DENOMINATORS

1. Find the LCD of the fractions (you can use multiples, product of primes, or division).
2. Write each fraction as an equivalent one with the LCD as denominator.
3. Add the fractions and reduce the answer, if possible.

We illustrate the procedure in Example 4, where we use multiples to find the LCD, and in Example 5, where we first find the LCD of $\frac{1}{8}$, $\frac{1}{12}$, and $\frac{1}{10}$ and then add the fractions.

C > Using the LCD to Add Fractions**EXAMPLE 4** Finding the LCD using multiples and adding fractions

Add.

$$\frac{1}{60} + \frac{5}{18}$$

SOLUTION 4 The multiples of 60 are 60, 120, and 180, so the LCD of 60 and 18 is 180. We need to write $\frac{1}{60}$ and $\frac{5}{18}$ with a denominator of 180. To have a denominator of 180, we multiply the denominator of $\frac{1}{60}$ (and hence the numerator) by 3. Similarly, we multiply the numerator and denominator of $\frac{5}{18}$ by 10, obtaining

$$\frac{1}{60} = \frac{1 \cdot 3}{60 \cdot 3} = \frac{3}{180} \quad \text{and} \quad \frac{5}{18} = \frac{5 \cdot 10}{18 \cdot 10} = \frac{50}{180}$$

Thus,

$$\frac{1}{60} + \frac{5}{18} = \frac{3}{180} + \frac{50}{180} = \frac{53}{180}$$

(53 is prime, so this fraction cannot be reduced.)

PROBLEM 4

Add.

$$\frac{1}{40} + \frac{5}{12}$$

Can we add three fractions like $\frac{1}{8} + \frac{1}{12} + \frac{1}{10}$? Of course. We first illustrate how to find the LCD using **all** methods. (You choose the one you prefer.) Then we add the fractions.

Answers to PROBLEMS

3. $\frac{47}{36}$ or $1\frac{11}{36}$ 4. $\frac{53}{120}$

Method 1

Step 1. Write 8, 12, and 10 as products of primes.

$$\begin{array}{l} 8 = 2^3 \\ 12 = 2^2 \cdot 3 \\ 10 = 2 \cdot 5 \end{array}$$

Step 2. Select each prime to the highest power to which it occurs (2^3 , 3, 5).

Step 3. The product of the factors from Step 2 is the LCD—that is,
 $2^3 \cdot 3 \cdot 5 = 120$

Method 2

Step 1. Divide by 2.
Divide by 2.

2	8	12	10
2	4	6	5
	2	3	5

Step 2. Remember to circle the 5 and carry it to the next line.

Step 3. The LCD is
 $2 \cdot 2 \cdot 2 \cdot 3 \cdot 5 = 120$

Method 3 Note that you can also find the LCD by listing the multiples of the *largest* denominator, which is 12, until you find a multiple of 12 that is divisible by 8 and 10.

Multiples of 12 are 12, 24, 36, 48, 60, 72, 84, 96, 108, and 120. Finally! 120 is divisible by 8 and by 10, so 120 is the LCD.

EXAMPLE 5 Adding three fractions with unlike denominators

Add.

$$\frac{1}{8} + \frac{1}{12} + \frac{1}{10}$$

SOLUTION 5 The LCD is 120, so we write the fractions with 120 as denominator.

$$\frac{1}{8} = \frac{1 \cdot 15}{8 \cdot 15} = \frac{15}{120}, \quad \frac{1}{12} = \frac{1 \cdot 10}{12 \cdot 10} = \frac{10}{120}, \quad \frac{1}{10} = \frac{1 \cdot 12}{10 \cdot 12} = \frac{12}{120}$$

Thus,

$$\begin{aligned} & \frac{1}{8} + \frac{1}{12} + \frac{1}{10} \\ &= \frac{15}{120} + \frac{10}{120} + \frac{12}{120} \\ &= \frac{15 + 10 + 12}{120} = \frac{37}{120} \end{aligned}$$

PROBLEM 5

Add.

$$\frac{1}{8} + \frac{1}{12} + \frac{1}{9}$$

D > Subtraction of Fractions

Now that you know how to add, *subtraction* is no problem. All the rules we have mentioned still apply! Thus,

$$\begin{aligned} \frac{5}{8} - \frac{2}{8} &= \frac{5-2}{8} = \frac{3}{8} \\ \frac{7}{9} - \frac{1}{9} &= \frac{7-1}{9} = \frac{6}{9} = \frac{2}{3} \end{aligned}$$

Example 6 shows how to subtract fractions involving *different* denominators.

As with addition, we find the LCD first.

EXAMPLE 6 Subtracting fractions with unlike denominators

Subtract.

a. $\frac{7}{12} - \frac{1}{18}$

b. $\frac{8}{15} - \frac{6}{25}$

SOLUTION 6

a. We first get the LCD of the fractions using multiples. Since the multiples of 18 are 18, 36, the LCD is 36. We can also use product of primes or division to find the LCD as shown next.

PROBLEM 6

Subtract.

a. $\frac{7}{12} - \frac{1}{10}$

b. $\frac{11}{15} - \frac{3}{20}$

(continued)

Answers to PROBLEMS

5. $\frac{23}{72}$ 6. a. $\frac{29}{60}$ b. $\frac{7}{12}$

METHOD 1

Step 1. $12 = |2^2| \cdot |3|$
 $18 = |2| \cdot |3^2|$

Step 2. Select 2 to the highest power to which it occurs (2^2) and 3 to the highest power to which it occurs (3^2).

Step 3. The LCD is $2^2 \cdot 3^2 = 36$.

METHOD 2

Step 1. $2 \begin{array}{|l} 12 \\ 18 \end{array}$
Step 2. $3 \begin{array}{|l} 6 \\ 9 \end{array}$
 $2 \quad 3$

Step 3. The LCD is $2 \cdot 3 \cdot 2 \cdot 3 = 36$

We then write each fraction with 36 as the denominator.

$$\frac{7}{12} = \frac{7 \cdot 3}{12 \cdot 3} = \frac{21}{36} \quad \text{and} \quad \frac{1}{18} = \frac{1 \cdot 2}{18 \cdot 2} = \frac{2}{36}$$

Thus,

$$\frac{7}{12} - \frac{1}{18} = \frac{21}{36} - \frac{2}{36} = \frac{21 - 2}{36} = \frac{19}{36}$$

b. To find the LCD of $\frac{8}{15}$ and $\frac{6}{25}$, write the multiples of 25, the larger of the two denominators, until you get a multiple that is divisible by 15. The multiples of 25 are

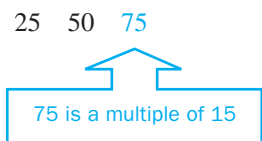

The LCD is 75.

Next, we write $\frac{8}{15}$ and $\frac{6}{25}$ using the LCD 75 as the denominator

$$\frac{8}{15} = \frac{8 \cdot 5}{15 \cdot 5} = \frac{40}{75} \quad \text{and} \quad \frac{6}{25} = \frac{6 \cdot 3}{25 \cdot 3} = \frac{18}{75}$$

Thus, $\frac{8}{15} - \frac{6}{25} = \frac{40}{75} - \frac{18}{75} = \frac{40 - 18}{75} = \frac{22}{75}$

EXAMPLE 7 Adding and subtracting fractions

Add and subtract.

a. $\frac{5}{9} + \frac{3}{8} - \frac{1}{12}$

b. $\frac{7}{8} - \frac{1}{3} + \frac{7}{12}$

SOLUTION 7

a. We first get the LCD of the fractions. (Use primes or division.)

METHOD 1

Step 1. $9 = |3^2|$
 $8 = |2^3|$
 $12 = |2^2| \cdot |3|$

Step 2. Select 2 to the highest power to which it occurs (2^3) and 3 to the highest power to which it occurs (3^2).

Step 3. The LCD is $2^3 \cdot 3^2 = 72$.

METHOD 2

Step 1. $2 \begin{array}{|l} 9 \\ 8 \end{array}$
 $2 \begin{array}{|l} 4 \\ 6 \end{array}$
 $3 \begin{array}{|l} 3 \\ 2 \end{array}$
 $3 \quad 2 \quad 1$

Step 2. No prime divides 3, 2, and 1.

Step 3. The LCD is $2 \cdot 2 \cdot 3 \cdot 3 \cdot 2 = 72$

PROBLEM 7

Add and subtract.

a. $\frac{3}{8} + \frac{1}{6} - \frac{2}{9}$

b. $\frac{7}{8} - \frac{1}{3} + \frac{11}{12}$

Answers to PROBLEMS

7. **a.** $\frac{23}{72}$ **b.** $\frac{35}{24} = 1\frac{11}{24}$

We now rewrite each fraction with a denominator of 72.

$$\frac{5}{9} = \frac{5 \cdot 8}{9 \cdot 8} = \frac{40}{72}, \quad \frac{3}{8} = \frac{3 \cdot 9}{8 \cdot 9} = \frac{27}{72}, \quad \frac{1}{12} = \frac{1 \cdot 6}{12 \cdot 6} = \frac{6}{72}$$

Thus

$$\frac{5}{9} + \frac{3}{8} - \frac{1}{12} = \frac{40}{72} + \frac{27}{72} - \frac{6}{72} = \frac{40 + 27 - 6}{72} = \frac{61}{72}$$

b. The LCD of $\frac{7}{8}$, $\frac{1}{3}$, and $\frac{7}{12}$ is 24.

$$\frac{7}{8} = \frac{7 \cdot 3}{8 \cdot 3} = \frac{21}{24}$$

$$\frac{1}{3} = \frac{1 \cdot 8}{3 \cdot 8} = \frac{8}{24}$$

$$\frac{7}{12} = \frac{7 \cdot 2}{12 \cdot 2} = \frac{14}{24}$$

Thus,

$$\frac{7}{8} - \frac{1}{3} + \frac{7}{12} = \frac{21}{24} - \frac{8}{24} + \frac{14}{24} = \frac{27}{24} = \frac{9}{8} = 1\frac{1}{8}$$

E > Graphs and Fractions

GREEN MATH

EXAMPLE 8 It is all garbage

A popular way to display information is a **pie chart (circle graph)** like the one shown illustrating what fraction of the 254 million tons of Municipal Solid Waste (MSW) generated in the United States in a recent year corresponded to different materials such as food scraps ($\frac{1}{8}$), paper and paperboard ($\frac{13}{40}$), glass ($\frac{1}{20}$), and metals ($\frac{2}{25}$).

- Which was the largest category of MSW generated?
- Which was the smallest category of MSW generated?
- What fraction of the garbage was plastics?
- What fraction of the garbage was metal or glass?

SOLUTION 8

- The largest category corresponds to the largest “slice”: **paper and paperboard**.
- The smallest category is the smallest “slice”: **Other**.
- $\frac{3}{25}$ was plastics.
- $\frac{2}{25} + \frac{1}{20}$ was metal or glass. To add these two fractions, we note that the LCD is 100, so we write both fractions with a denominator of 100, and add as shown:

$$\frac{2}{25} + \frac{1}{20} = \frac{2 \cdot 4}{25 \cdot 4} + \frac{1 \cdot 5}{20 \cdot 5} = \frac{8}{100} + \frac{5}{100} = \frac{13}{100}$$

Source: <http://www.epa.gov/epawaste/nonhaz/municipal/pubs/msw07-rpt.pdf>.

PROBLEM 8

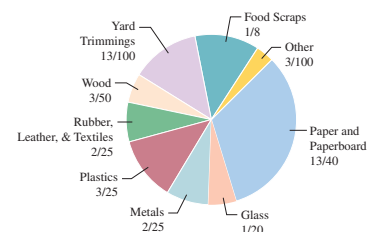

- Which category is the second largest?
- Which category is the third largest?
- What fraction of the garbage was metals?
- What fraction of the garbage was plastics or glass?

Answers to PROBLEMS

8. a. Yard trimmings b. Food scraps c. $\frac{2}{25}$ d. $\frac{17}{100}$



> Practice Problems > Self-Tests
> Media-rich eBooks > e-Professors > Videos

> Exercises 2.5

< A > Adding Fractions with the Same Denominator In Problems 1–10, add (reduce answers to lowest terms).

- | | | |
|---------------------------------|---------------------------------|--------------------------------|
| 1. $\frac{1}{3} + \frac{1}{3}$ | 2. $\frac{1}{5} + \frac{2}{5}$ | 3. $\frac{1}{7} + \frac{4}{7}$ |
| 4. $\frac{1}{9} + \frac{7}{9}$ | 5. $\frac{2}{9} + \frac{4}{9}$ | 6. $\frac{3}{8} + \frac{5}{8}$ |
| 7. $\frac{1}{6} + \frac{5}{6}$ | 8. $\frac{2}{9} + \frac{10}{9}$ | 9. $\frac{3}{4} + \frac{5}{4}$ |
| 10. $\frac{6}{7} + \frac{8}{7}$ | | |

< B > Adding Fractions with Different Denominators In Problems 11–26, add using multiples to find the LCD (reduce answers to lowest terms).

- | | | | |
|-----------------------------------|--------------------------------------|-------------------------------------|------------------------------------|
| 11. $\frac{1}{3} + \frac{1}{5}$ | 12. $\frac{1}{4} + \frac{1}{6}$ | 13. $\frac{1}{2} + \frac{1}{6}$ | 14. $\frac{7}{8} + \frac{3}{4}$ |
| 15. $\frac{1}{2} + \frac{4}{5}$ | 16. $\frac{5}{6} + \frac{3}{10}$ | 17. $\frac{4}{7} + \frac{3}{14}$ | 18. $\frac{1}{6} + \frac{11}{12}$ |
| 19. $\frac{1}{2} + \frac{3}{8}$ | 20. $\frac{5}{12} + \frac{1}{6}$ | 21. $\frac{1}{40} + \frac{1}{18}$ | 22. $\frac{5}{24} + \frac{7}{30}$ |
| 23. $\frac{2}{65} + \frac{3}{26}$ | 24. $\frac{7}{120} + \frac{11}{150}$ | 25. $\frac{7}{120} + \frac{1}{180}$ | 26. $\frac{1}{90} + \frac{7}{120}$ |

< C > Using the LCD to Add Fractions In Problems 27–30, find the LCD and add the fractions.

- | | | |
|---|---|---|
| 27. $\frac{3}{10} + \frac{7}{20} + \frac{11}{60}$ | 28. $\frac{5}{9} + \frac{7}{12} + \frac{5}{18}$ | 29. $\frac{11}{14} + \frac{5}{6} + \frac{8}{9}$ |
| 30. $\frac{5}{36} + \frac{1}{80} + \frac{7}{90}$ | | |

< D > Subtraction of Fractions In Problems 31–50, add and subtract as indicated (reduce answers to lowest terms).

- | | | |
|--|--|---|
| 31. $\frac{3}{7} - \frac{1}{7}$ | 32. $\frac{5}{8} - \frac{2}{8}$ | 33. $\frac{5}{6} - \frac{1}{6}$ |
| 34. $\frac{3}{8} - \frac{1}{8}$ | 35. $\frac{5}{12} - \frac{1}{4}$ | 36. $\frac{1}{3} - \frac{1}{6}$ |
| 37. $\frac{1}{2} - \frac{2}{5}$ | 38. $\frac{1}{4} - \frac{1}{6}$ | 39. $\frac{5}{20} - \frac{7}{40}$ |
| 40. $\frac{7}{10} - \frac{3}{20}$ | 41. $\frac{7}{8} - \frac{5}{12}$ | 42. $\frac{8}{15} - \frac{2}{25}$ |
| 43. $\frac{13}{60} - \frac{1}{48}$ | 44. $\frac{19}{24} - \frac{7}{60}$ | 45. $\frac{8}{9} - \frac{2}{9} - \frac{1}{9}$ |
| 46. $\frac{7}{11} - \frac{3}{11} - \frac{2}{11}$ | 47. $\frac{3}{4} + \frac{5}{12} - \frac{1}{6}$ | 48. $\frac{5}{6} + \frac{1}{9} - \frac{1}{3}$ |
| 49. $\frac{9}{2} - \frac{7}{3}$ | 50. $\frac{11}{5} - \frac{7}{4}$ | |

51. A board $\frac{3}{4}$ inch thick is glued to another board $\frac{3}{8}$ inch thick. If the glue is $\frac{1}{32}$ inch thick, how thick is the result?

52. Candy Sweet bought $\frac{1}{4}$ pound of chocolate candy and $\frac{1}{2}$ pound of caramels. How many pounds of candy is this?

53. A father left $\frac{1}{4}$ of his estate to his daughter, $\frac{1}{2}$ to his wife, and $\frac{1}{8}$ to his son. How much of the estate remained?
55. Human bones are $\frac{1}{4}$ water, $\frac{3}{10}$ living tissue, and the rest minerals. The fraction of the bone that is minerals is $1 - \frac{1}{4} - \frac{3}{10}$. Find this fraction.

54. A recent survey found that $\frac{3}{10}$ of the American people work long hours and smoke, while $\frac{1}{5}$ are overweight. Thus, the fraction of people who are neither of these is $1 - \frac{1}{5} - \frac{3}{10}$. What fraction is that?

E **Graphs and Fractions** The circle graph has 12 “slices” and will be used in Problems 56–58.

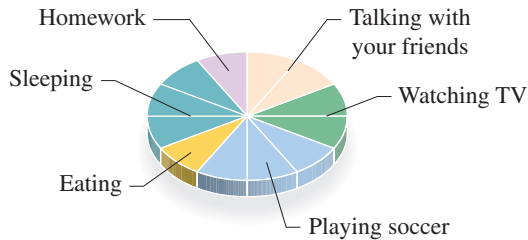

Source: Adapted from Learn.co.uk.

The circle graph is divided into 12 equal parts (slices).

56. What reduced fraction of the time was spent eating?
57. What reduced fraction of the time was spent watching TV?
58. What fraction of the time was spent doing homework?

The circle graph will be used in Problems 59–60. The graph shows the fraction of the budget spent by a company on its employees.

Employee Expenses

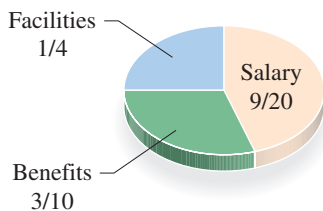

Source: Adapted from Visual Mining, Inc.

59. What fraction of the expenses was for benefits or salary?
60. What fraction of the expenses was for benefits or facilities?

The circle graph will be used in Problems 61–62. The graph shows the fraction of the days in which it is sunny, snowy, rainy, or cloudy in a certain city.

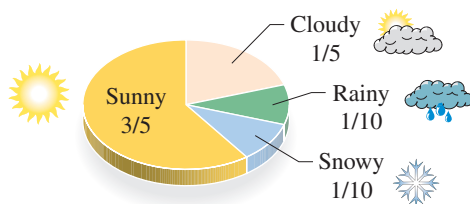

61. What reduced fraction of the days is rainy or snowy?
62. What reduced fraction of the days is rainy or cloudy?

The circle graph will be used in Problems 63–65. The graph shows the mode of transportation used by people going to work in England.

Ways of Traveling to Work

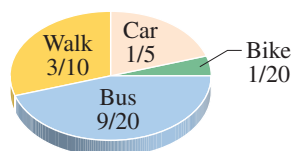

63. What fraction of the people walk or use a car?
64. What fraction of the people bike or use a car?
65. What fraction of the people *do not* walk?

The circle graph shows the fraction of the money spent by a typical community college student in five different areas and will be used in Problems 66–70. The expenses total \$3000.

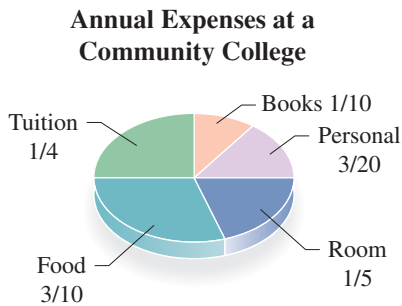

66. a. What fraction of the expenses go toward food and tuition?
b. What amount is for food and tuition?
67. a. What fraction of the expenses go toward food and room?
b. What amount is for food and room?
68. a. What fraction of the expenses go toward books and tuition?
b. What amount is for books and tuition?
69. a. What fraction of the expenses go toward books, personal, and room?
b. What amount is for books, personal, and room?
70. a. What fraction of the expenses go toward paying for everything except books?
b. What amount is for everything except books?

>>> Applications: Green Math

The garbage pizza A project by the Illinois Environmental Protection Agency and The Waste Management and Research Center created a pizza, but not the ones with the pepperoni, cheese and jalapenos. No, no, they created the **garbage pizza**, illustrating the fact that each citizen of Illinois created enough garbage to make a $5\frac{1}{2}$ pound pizza. The graph will be used in Exercises 71–78

71. What is the biggest slice of the pizza made of?
72. What is the smallest slice of the pizza made of?
73. What reduced fraction of the pizza would be Wood ($\frac{7}{100}$) and Textiles ($\frac{1}{20}$)?
74. What fraction of the pizza would be Glass ($\frac{3}{50}$) and Metals ($\frac{9}{100}$)?
75. Which two categories make up about half of the pizza? (There are two answers!)
76. What fraction of the pizza would be Paper/Paperboard and Food Scraps? What about Paper/Paperboard and Plastics?
77. $\frac{3}{100}$ of the $5\frac{1}{2}$ pound pizza is Rubber and Leather. How many pounds is that?
78. $\frac{13}{100}$ of the $5\frac{1}{2}$ pound pizza is Food Scraps. How many pounds is that?

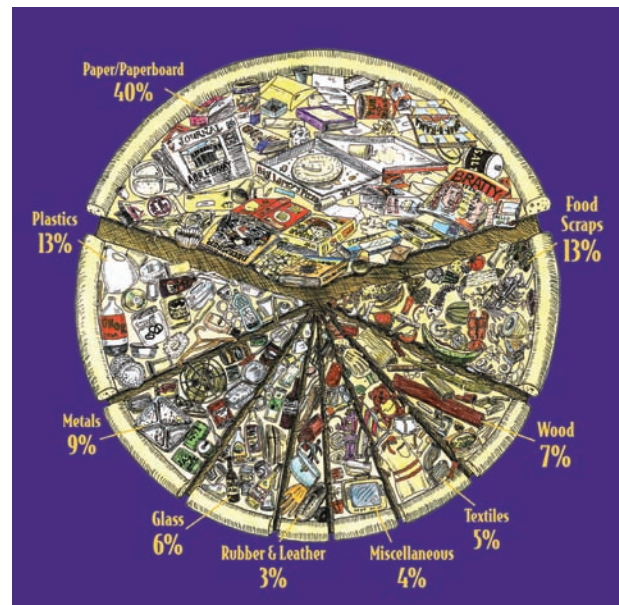

>>> Using Your Knowledge

Hot dogs, buns, and LCDs In this section, we learned how to find the LCD of several fractions by finding the multiples of the *larger* denominator until you get a multiple of the *smaller* denominators. We are going to apply this theory to purchasing hot dogs and buns! Have you noticed that hot dogs come 10 to a package but buns come in packages of 8 or 12?

79. What is the smallest number of packages of hot dogs (10 to a package) and buns (8 to a package) you must buy so that you have as many hot dogs as you have buns? (*Hint: Think of multiples.*)
80. If buns are sold in packages of 12 and hot dogs in packages of 10, what is the smallest number of packages of hot dogs and buns you must buy so that you have as many hot dogs as you have buns?

>>> Write On

- 81.** When adding $\frac{3}{4} + \frac{1}{6}$ we mentioned we could use the equivalent fractions $\frac{18}{24}$ and $\frac{4}{24}$, then do the addition. You can always use the product of the denominators as the denominator of the sum. Is this correct? Why or why not?
- 82.** Write in your own words the process you prefer for finding the LCD of two fractions.
- 83.** Write in your words the procedure you use to add fractions with different denominators.
- 84.** Write in your own words the procedure you use to subtract fractions with different denominators.

>>> Concept Checker

Fill in the blank(s) with the correct word(s), phrase, or mathematical statement.

85. $\frac{a}{c} + \frac{b}{c} =$ _____

86. $\frac{a}{c} - \frac{b}{c} =$ _____

$$\frac{a+c}{b}$$

$$\frac{a-b}{c}$$

$$\frac{a+b}{c}$$

$$\frac{a-c}{b}$$

>>> Mastery Test

- 87.** Find the LCD of $\frac{1}{30}$ and $\frac{1}{18}$.
- 88.** Add: $\frac{1}{10} + \frac{7}{10}$
- 89.** Add: $\frac{1}{8} + \frac{1}{6}$
- 90.** Add: $\frac{1}{10} + \frac{7}{4}$
- 91.** Perform the indicated operation: $\frac{1}{10} + \frac{1}{12} + \frac{3}{8}$
- 92.** Subtract: $\frac{5}{12} - \frac{1}{18}$
- 93.** Perform the indicated operation: $\frac{3}{10} + \frac{1}{12} - \frac{1}{8}$
- 94.** The graph shows the concerns of a mythical chinchilla.
- What fraction of the time is the chinchilla concerned about eating too much or too little?
 - What fraction of the time does the chinchilla either have no concerns or act weird?

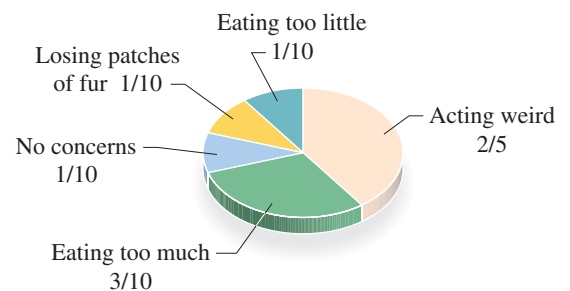

>>> Skill Checker

Write as an improper fraction.

95. $3\frac{1}{5}$

96. $5\frac{3}{11}$

97. $6\frac{7}{8}$

98. $7\frac{10}{11}$

Write as a mixed number.

99. $\frac{10}{6}$

100. $\frac{45}{6}$

2.6

Addition and Subtraction of Mixed Numbers

▶ Objectives

You should be able to:

- A** > Add mixed numbers having the same denominator.
- B** > Add mixed numbers with different denominators using the idea of a multiple to find the LCD.
- C** > Subtract mixed numbers with different denominators using the idea of a multiple to find the LCD.
- D** > Use the LCD of two or more fractions to add or subtract mixed numbers.
- E** > Use addition of mixed numbers to find perimeters and greenhouse emissions.

▶ To Succeed, Review How To . . .

1. Write a number as a product of primes using exponents. (pp. 77–78)
2. Write a mixed number as an improper fraction and vice versa. (p. 117)

▶ Getting Started

In many cases, the packaging of products remains the same but the actual content is reduced. Watch your fractions! For example, the contents of the Edy's ice cream went from $1\frac{3}{4}$ quarts to $1\frac{1}{2}$ quarts. How much was the decrease? To find the answer you have to subtract $1\frac{1}{2}$ from $1\frac{3}{4}$, that is, find $1\frac{3}{4} - 1\frac{1}{2}$. This involves the subtraction of mixed numbers and you can do it two ways:

1. Subtract the whole number part ($1 - 1 = 0$) and then subtract the fraction part ($\frac{3}{4} - \frac{1}{2} = \frac{3}{4} - \frac{2}{4} = \frac{1}{4}$)
2. Convert each mixed number to a fraction ($1\frac{3}{4} = \frac{7}{4}$ and $1\frac{1}{2} = \frac{3}{2}$), then subtract

$$1\frac{3}{4} - 1\frac{1}{2} = \frac{7}{4} - \frac{3}{2} = \frac{7}{4} - \frac{6}{4} = \frac{1}{4}$$

In this section, we will study the addition and subtraction of mixed numbers.

A > Adding Mixed Numbers with the Same Denominator

Can we add $3\frac{1}{5} + 1\frac{2}{5}$? Of course! You can change $3\frac{1}{5}$ and $1\frac{2}{5}$ to improper fractions first. Since

$$3\frac{1}{5} = \frac{5 \cdot 3 + 1}{5} = \frac{16}{5} \quad \text{and} \quad 1\frac{2}{5} = \frac{5 \cdot 1 + 2}{5} = \frac{7}{5}$$

we have

$$3\frac{1}{5} + 1\frac{2}{5} = \frac{16}{5} + \frac{7}{5} = \frac{16+7}{5} = \frac{23}{5} = 4\frac{3}{5}$$

You can also add $3\frac{1}{5}$ and $1\frac{2}{5}$ vertically, like this:

$$\begin{array}{r} 3\frac{1}{5} \\ + 1\frac{2}{5} \\ \hline 4\frac{3}{5} \end{array}$$

Add the whole parts. →

↑ Add the fractional parts first.

Note that when adding mixed numbers, the answer is given as a mixed number.

EXAMPLE 1 Adding mixed numbers: same denominators

Add $2\frac{1}{7} + 1\frac{3}{7}$.

SOLUTION 1

Method 1. $2\frac{1}{7} + 1\frac{3}{7} = \frac{15}{7} + \frac{10}{7} = \frac{25}{7} = 3\frac{4}{7}$

Method 2.

$$\begin{array}{r} 2\frac{1}{7} \\ + 1\frac{3}{7} \\ \hline 3\frac{4}{7} \end{array}$$

Add whole parts. →

↑ Add fractional parts.

PROBLEM 1

Add $3\frac{1}{9} + 2\frac{4}{9}$.

B > Adding Mixed Numbers with Different Denominators

If we have mixed numbers with different denominators, we must find the LCD first, as in Example 2.

EXAMPLE 2 Adding mixed numbers with different denominators

Add $1\frac{3}{4} + \frac{2}{15}$.

SOLUTION 2 We first find the LCD. The multiples of 15 (the larger of the two denominators) are

15, 30, 45, 60 ← Multiple of 4 (4 goes into it)
Not multiples of 4

Thus, the LCD of $1\frac{3}{4}$ and $\frac{2}{15}$ is 60. Now $1\frac{3}{4} = \frac{7}{4}$. Thus, $\frac{7}{4} = \frac{105}{60}$ and $\frac{2}{15} = \frac{8}{60}$. So

$$1\frac{3}{4} + \frac{2}{15} = \frac{105}{60} + \frac{8}{60} = \frac{113}{60} = 1\frac{53}{60}$$

PROBLEM 2

Add $1\frac{3}{4} + \frac{1}{6}$.

Answers to PROBLEMS

1. $5\frac{5}{9}$ 2. $1\frac{11}{12}$

EXAMPLE 3 Adding mixed numbers: different denominatorsAdd $3\frac{3}{4} + 2\frac{5}{6}$.**SOLUTION 3****Method 1.** Convert to improper fractions first.

$$3\frac{3}{4} = \frac{15}{4} \quad \text{and} \quad 2\frac{5}{6} = \frac{17}{6}$$

The LCD of 4 and 6 is 12, so we rewrite the fractions with this denominator. (Note that 4 and 6 divide into 12.)

$$3\frac{3}{4} = \frac{15}{4} = \frac{15 \cdot 3}{4 \cdot 3} = \frac{45}{12} \quad \text{and} \quad 2\frac{5}{6} = \frac{17}{6} = \frac{17 \cdot 2}{6 \cdot 2} = \frac{34}{12}$$

Thus,

$$3\frac{3}{4} + 2\frac{5}{6} = \frac{45}{12} + \frac{34}{12} = \frac{45 + 34}{12} = \frac{79}{12} = 6\frac{7}{12}$$

Method 2. Write the fractional parts using the LCD 12 as their denominator:

$$\begin{aligned} 3\frac{3}{4} &= 3\frac{9}{12} \quad \left(\frac{3}{4} = \frac{3 \cdot 3}{4 \cdot 3} = \frac{9}{12}\right) \\ + 2\frac{5}{6} &= +2\frac{10}{12} \quad \left(\frac{5}{6} = \frac{5 \cdot 2}{6 \cdot 2} = \frac{10}{12}\right) \\ \hline 5\frac{19}{12} &= 5 + \frac{19}{12} \\ &= 5 + 1\frac{7}{12} = 6\frac{7}{12} \end{aligned}$$

PROBLEM 3Add $5\frac{1}{4} + 1\frac{5}{6}$.**C** > Subtracting Mixed Numbers

The rules we mentioned for adding mixed numbers also apply to the subtraction of mixed numbers. We illustrate the procedure in Example 4.

EXAMPLE 4 Subtracting mixed numbers: different denominatorsSubtract **a.** $3\frac{1}{6} - 2\frac{5}{8}$.**b.** $4\frac{1}{8} - 3\frac{1}{3}$.**SOLUTION 4** **a.** The LCD of 6 and 8 is 24.**Method 1.** First convert to improper fractions.

$$3\frac{1}{6} = \frac{19}{6} \quad \text{and} \quad 2\frac{5}{8} = \frac{21}{8}$$

Now, write $\frac{19}{6}$ and $\frac{21}{8}$ with 24 as a denominator by multiplying the numerator and denominator of $\frac{19}{6}$ by 4 and the numerator and denominator of $\frac{21}{8}$ by 3. We have

$$\begin{aligned} 3\frac{1}{6} - 2\frac{5}{8} &= \frac{19 \cdot 4}{6 \cdot 4} - \frac{21 \cdot 3}{8 \cdot 3} \\ &= \frac{76}{24} - \frac{63}{24} \\ &= \frac{13}{24} \end{aligned}$$

PROBLEM 4Subtract **a.** $4\frac{1}{6} - 3\frac{2}{9}$. **b.** $5\frac{1}{8} - 4\frac{1}{6}$.

Answers to PROBLEMS

3. $7\frac{1}{12}$ 4. **a.** $\frac{17}{18}$ **b.** $\frac{23}{24}$

Method 2. Write the fractional parts using the LCD 24 as the denominator.

$$\begin{array}{r} 3\frac{1}{6} = 3\frac{4}{24} \left(\frac{1}{6} = \frac{1 \cdot 4}{6 \cdot 4} = \frac{4}{24} \right) \\ -2\frac{5}{8} = -2\frac{15}{24} \left(\frac{5}{8} = \frac{5 \cdot 3}{8 \cdot 3} = \frac{15}{24} \right) \end{array}$$

We cannot subtract $\frac{15}{24}$ from $\frac{4}{24}$. We have to borrow.

We can then rewrite the problem as

$$\begin{array}{r} 3\frac{1}{6} = 3\frac{4}{24} = 2\frac{28}{24} \\ -2\frac{5}{8} = -2\frac{15}{24} = -2\frac{15}{24} \\ \hline \frac{13}{24} \end{array}$$

Write $3\frac{4}{24}$ as $2 + \frac{24}{24} + \frac{4}{24} = 2\frac{28}{24}$.

Note that the answer is the same with either method.

b. The LCD of 8 and 3 is 24.

Method 1. First convert to improper fractions

$$4\frac{1}{8} = \frac{33}{8} \text{ and } 3\frac{1}{3} = \frac{10}{3}$$

Write $\frac{33}{8}$ and $\frac{10}{3}$ with 24 as the denominator. This can be done by multiplying the numerator and denominator of $\frac{33}{8}$ by 3 and the numerator and denominator of $\frac{10}{3}$ by 8. We then write

$$\begin{aligned} 4\frac{1}{8} - 3\frac{1}{3} &= \frac{33}{8} - \frac{10}{3} = \frac{33 \cdot 3}{8 \cdot 3} - \frac{10 \cdot 8}{3 \cdot 8} \\ &= \frac{99}{24} - \frac{80}{24} \\ &= \frac{19}{24} \end{aligned}$$

Method 2. Write each fraction using the LCD 24 as its denominator.

$$\begin{array}{r} 4\frac{1}{8} = 4\frac{3}{24} \\ -3\frac{1}{3} = 3\frac{8}{24} \end{array}$$

We cannot subtract $\frac{8}{24}$ from $\frac{3}{24}$, so we have to borrow from the 4. Write $4\frac{3}{24} = 3 + 1 + \frac{3}{24} = 3 + \frac{24}{24} + \frac{3}{24} = 3\frac{27}{24}$.

Then rewrite the problem as

$$\begin{array}{r} 4\frac{1}{8} = 4\frac{3}{24} = 3\frac{27}{24} \\ -3\frac{1}{3} = 3\frac{8}{24} = 3\frac{8}{24} \\ \hline \frac{19}{24} \end{array}$$

Note that the answer is the same with either method.

D > Addition and Subtraction of Mixed Numbers

Finally, we do a problem involving addition and subtraction with three mixed numbers.

EXAMPLE 5 Adding and subtracting mixed numbers

$$1\frac{5}{9} + 2\frac{3}{10} - 1\frac{1}{12} = \underline{\hspace{2cm}}$$

SOLUTION 5 We first find the LCD of $\frac{5}{9}$, $\frac{3}{10}$, and $\frac{1}{12}$.

METHOD 1

Step 1. Write the denominators as products of primes.

$$\begin{array}{l} 9 = | \quad | \quad | 3^2 \\ 10 = | 2 \cdot | \quad | 5 \\ 12 = | 2^2 \cdot | 3 \end{array}$$

Step 2. Select 2^2 , 3^2 , and 5.

Step 3. The LCD is

$$2^2 \cdot 3^2 \cdot 5 = 180.$$

METHOD 2

Step 1. Write the denominators in a horizontal row and divide by a prime divisor common to two or more numbers.

$$\begin{array}{r} 2 \overline{) 9 \ 10 \ 12} \\ 3 \overline{) 9 \ 5 \ 6} \\ \quad 3 \ 5 \ 2 \end{array}$$

Step 2. No prime divides 3, 5, and 2.

Step 3. The LCD is

$$2 \cdot 3 \cdot 3 \cdot 5 \cdot 2 = 180.$$

In either case, the LCD is 180. We now rewrite each of the fractions as an improper fraction with a denominator of 180.

$$\begin{aligned} 1\frac{5}{9} &= \frac{9 \cdot 1 + 5}{9} = \frac{14}{9} = \frac{14 \cdot 20}{9 \cdot 20} = \frac{280}{180} \\ 2\frac{3}{10} &= \frac{10 \cdot 2 + 3}{10} = \frac{23}{10} = \frac{23 \cdot 18}{10 \cdot 18} = \frac{414}{180} \\ 1\frac{1}{12} &= \frac{12 \cdot 1 + 1}{12} = \frac{13}{12} = \frac{13 \cdot 15}{12 \cdot 15} = \frac{195}{180} \end{aligned}$$

Thus,

$$\begin{aligned} 1\frac{5}{9} + 2\frac{3}{10} - 1\frac{1}{12} &= \frac{280}{180} + \frac{414}{180} - \frac{195}{180} \\ &= \frac{280 + 414 - 195}{180} \\ &= \frac{499}{180} \quad (\text{Note that } 499 \div 180 = 2 \text{ r } 139.) \\ &= 2\frac{139}{180} \end{aligned}$$

PROBLEM 5

$$1\frac{3}{8} + 2\frac{3}{10} - 2\frac{1}{12} = \underline{\hspace{2cm}}$$

E > Perimeter and Greenhouse Emissions

As you recall from Section 1.3, the **perimeter** of an object (geometric figure) is the distance around the object. Here is the definition.

PERIMETER

The *distance* around an object is its *perimeter*.

Answers to PROBLEMS

5. $1\frac{71}{120}$

EXAMPLE 6 Finding the perimeter

The dimensions of the family room are $21\frac{8}{12}$ feet by 15 feet. (Note that 21^8 means $21\frac{8}{12}$ feet and 15^0 means 15 feet.) How much baseboard molding do you need (red) for this room?

SOLUTION 6 If we disregard the fact that the doors need no baseboard molding, we simply need to find the perimeter of the room, which is:

$$21\frac{8}{12} \text{ feet} + 15 \text{ feet} + 21\frac{8}{12} \text{ feet} + 15 \text{ feet}$$

First note that $21\frac{8}{12}$ feet = $21\frac{2}{3}$ feet. Thus, we need

$$\begin{aligned} & 21\frac{2}{3} \text{ feet} + 15 \text{ feet} + 21\frac{2}{3} \text{ feet} + 15 \text{ feet} \\ &= 21\frac{2}{3} \text{ feet} + 21\frac{2}{3} \text{ feet} + 15 \text{ feet} + 15 \text{ feet} \\ &= 42\frac{4}{3} \text{ feet} + 30 \text{ feet} \\ &= \left(42 + 1\frac{1}{3}\right) \text{ feet} + 30 \text{ feet} \\ &= 43\frac{1}{3} \text{ feet} + 30 \text{ feet} \\ &= 73\frac{1}{3} \text{ feet of molding} \end{aligned}$$

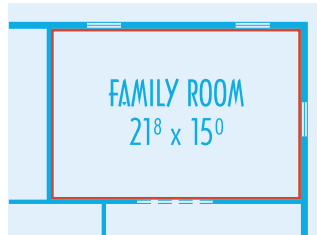
**PROBLEM 6**

How much molding is needed if the dimensions are 20^8 feet by 15 feet? Note: 15^0 means 15 ft

GREEN MATH

EXAMPLE 7 Greenhouse gas emissions

Greenhouse gases trap heat from the sun and warm the planet's surface. The pie chart shows the U.S. emissions of greenhouse gases in billion of metric tons of carbon dioxide equivalents (CO_2e).

- Which fuel accounts for the most CO_2e emissions?
- What are the combined CO_2e emissions of coal and petroleum?

SOLUTION 7

- The biggest piece of the pie (sector) is petroleum.
- The combined emissions of coal and petroleum correspond to $2\frac{1}{10} + 2\frac{3}{5}$ of the pie. To add these two mixed numbers we proceed as in Example 3 and convert to improper fractions first.

$$2\frac{1}{10} = \frac{21}{10} \quad \text{and} \quad 2\frac{3}{5} = \frac{13}{5}$$

The LCD of 10 and 5 is 10, so we rewrite $\frac{13}{5} = \frac{13 \cdot 2}{5 \cdot 2} = \frac{26}{10}$

$$\text{Thus, } 2\frac{1}{10} + 2\frac{3}{5} = \frac{21}{10} + \frac{26}{10} = \frac{47}{10} = 4\frac{7}{10}$$

This means that the combined emissions of coal and petroleum amount to $4\frac{7}{10}$ billion metric tons of CO_2e 's.

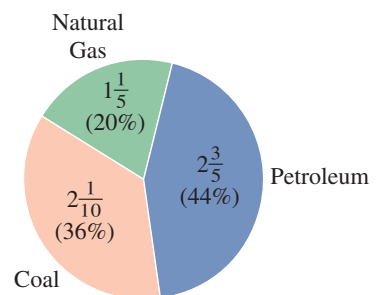
PROBLEM 7**Billion Metric Tons CO_2e** 

Source: Energy Information Administration, *Emissions of Greenhouse Gases in the United States 2006* (Nov. 2007).

- Which fuel accounts for the least CO_2e emissions?
- What are the combined CO_2e emissions of petroleum and natural gas?

Answers to PROBLEMS

6. $71\frac{1}{3}$ ft 7. a. Natural gas b. $3\frac{4}{5}$ billion metric tons



> Practice Problems > Self-Tests
> Media-rich eBooks > e-Professors > Videos

> Exercises 2.6

< A > Adding Mixed Numbers with the Same Denominator In Problems 1–10, add. Reduce if possible.

- | | | |
|----------------------------------|----------------------------------|---------------------------------|
| 1. $3\frac{1}{7} + 1\frac{3}{7}$ | 2. $3\frac{1}{9} + 4\frac{3}{9}$ | 3. $2\frac{1}{7} + \frac{3}{7}$ |
| 4. $5\frac{1}{9} + \frac{7}{9}$ | 5. $\frac{3}{8} + 5\frac{1}{8}$ | 6. $\frac{3}{8} + 2\frac{1}{8}$ |
| 7. $1\frac{3}{5} + 2\frac{4}{5}$ | 8. $2\frac{4}{7} + 5\frac{5}{7}$ | 9. $2 + 3\frac{1}{7}$ |
| 10. $3 + 4\frac{1}{8}$ | | |

< B > Adding Mixed Numbers with Different Denominators In Problems 11–20, add. Reduce if possible.

- | | | |
|-----------------------------------|-----------------------------------|--------------------------------------|
| 11. $2\frac{3}{4} + \frac{2}{15}$ | 12. $2\frac{3}{5} + \frac{3}{8}$ | 13. $1\frac{3}{10} + 2\frac{11}{12}$ |
| 14. $1\frac{4}{5} + 3\frac{7}{9}$ | 15. $1\frac{3}{4} + 2\frac{5}{6}$ | 16. $2\frac{4}{5} + 3\frac{5}{6}$ |
| 17. $8\frac{1}{7} + 3\frac{1}{9}$ | 18. $6\frac{1}{8} + 5\frac{3}{7}$ | 19. $9\frac{1}{11} + 3\frac{1}{10}$ |
| 20. $7\frac{3}{8} + 1\frac{1}{9}$ | | |

< C > Subtracting Mixed Numbers In Problems 21–34, subtract. Reduce if possible.

- | | | |
|--------------------------------------|--------------------------------------|-------------------------------------|
| 21. $3\frac{3}{7} - 1\frac{1}{7}$ | 22. $7\frac{5}{8} - 3\frac{3}{8}$ | 23. $4\frac{5}{6} - 3\frac{1}{6}$ |
| 24. $5\frac{3}{8} - 2\frac{1}{8}$ | 25. $3\frac{1}{12} - 1\frac{1}{4}$ | 26. $3\frac{1}{3} - 1\frac{5}{6}$ |
| 27. $3\frac{1}{2} - 2\frac{4}{5}$ | 28. $4\frac{1}{4} - 3\frac{5}{6}$ | 29. $4\frac{1}{20} - 3\frac{3}{40}$ |
| 30. $8\frac{3}{10} - 7\frac{9}{20}$ | 31. $3\frac{7}{8} - 1\frac{5}{12}$ | 32. $5\frac{8}{15} - 1\frac{2}{25}$ |
| 33. $3\frac{13}{60} - 3\frac{1}{48}$ | 34. $4\frac{19}{24} - 4\frac{7}{60}$ | |

< D > Addition and Subtraction of Mixed Numbers In Problems 35–44, add and subtract as indicated. Reduce if possible.

- | | | |
|---|--|---|
| 35. $3\frac{8}{9} + 1\frac{2}{9} - 1\frac{1}{9}$ | 36. $4\frac{7}{11} + 2\frac{3}{11} - 3\frac{2}{11}$ | 37. $3\frac{3}{4} + 1\frac{1}{12} - 1\frac{1}{6}$ |
| 38. $2\frac{5}{6} + 3\frac{1}{9} - 2\frac{1}{3}$ | 39. $4\frac{1}{2} - 2\frac{1}{3} + 3\frac{1}{4}$ | 40. $2\frac{1}{5} - 1\frac{3}{4} + 5\frac{1}{2}$ |
| 41. $3\frac{1}{65} + 10\frac{1}{26} - 1\frac{2}{65}$ | 42. $1\frac{7}{62} + 3\frac{1}{155} - 1\frac{3}{62}$ | |
| 43. $14\frac{11}{45}$
$+ 7\frac{7}{60}$
$- 3\frac{8}{45}$ | 44. $10\frac{3}{26}$
$+ 5\frac{1}{91}$
$- 3\frac{1}{26}$ | |

>>> Applications

- 45. Body temperature** The normal body temperature is $98\frac{6}{10}$ degrees Fahrenheit. Carlos had the flu, and his temperature was $101\frac{6}{10}$ degrees. How many degrees above normal is that?
- 47. Human brain weight** As stated in Problem 46, the average human brain weighs approximately $3\frac{1}{8}$ pounds. The heaviest brain ever recorded was that of Ivan Sergeevich Turgenev, a Russian author. His brain weighed approximately $4\frac{7}{16}$ pounds. How much above the average is this weight?
- 49. Ingredients in recipe** A recipe uses $2\frac{1}{2}$ cups of flour and $\frac{3}{4}$ cup of sugar. What is the total number of cups of these ingredients?
- 51. Packages weight** Sir Loin Stake, an English butcher, sold packages weighing $\frac{1}{4}$, $2\frac{1}{2}$, and 3 pounds. What was the total weight of the three packages?
- 53. Human bones composition** Human bones are $\frac{1}{4}$ water, $\frac{9}{20}$ minerals, and the rest living tissue. The fraction of the bone that is living tissue is $1 - \frac{1}{4} - \frac{9}{20}$. Find this fraction.
- 55. Average work hours: Canadians and Americans** Americans work an average of $46\frac{3}{5}$ hours per week, while Canadians work $38\frac{9}{10}$. How many more hours per week do Americans work?
- 46. Human brain weight** The average human brain weighs approximately $3\frac{1}{8}$ pounds. The brain of the writer Anatole France weighed only $2\frac{1}{4}$ pounds. How much under the average was that?
- 48. Ride length** Desi rode $\frac{3}{4}$ of a mile. She then rode $1\frac{2}{3}$ miles more. How far did she ride in all?
- 50. Thickness of board** A board $1\frac{3}{4}$ inch thick is glued to another board $\frac{5}{8}$ inch thick. If the glue is $\frac{1}{32}$ inch thick, how thick is the result?
- 52. Working, smoking, and weight** A recent survey found that $\frac{3}{10}$ of the American people work long hours and smoke, while $\frac{1}{5}$ are overweight. Thus, the fraction of people who are neither of these is $1 - \frac{1}{5} - \frac{3}{10}$. What fraction is that?
- 54. Newspaper expenditures** Americans spend $\$6\frac{1}{2}$ billion on daily newspapers and $\$3\frac{1}{10}$ billion on Sunday newspapers. How many billions of dollars are spent on newspapers?
- 56. Household chore help from husbands** Do husbands help with the household chores? A recent survey estimated that husbands spend about $7\frac{1}{2}$ hours on weekdays helping around the house, $2\frac{3}{5}$ hours on Saturday, and 2 hours on Sunday. How many hours do husbands work around the house during the entire week?

>>> Applications: Green Math

- 57.** Referring to the pie chart in Example 7, what are the combined CO_2e emissions of coal and natural gas?
- 58.** Referring to the pie chart in Example 7, how many more billion metric tons of CO_2e are produced by petroleum than by coal?

- < E > Perimeter** In Problems 59–60, find the approximate amount of baseboard molding needed for the rooms shown (include door openings).

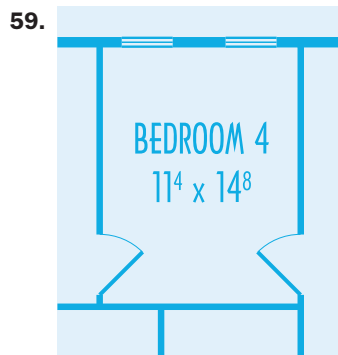

Note: 11^4 means $11\frac{4}{12}$ feet.

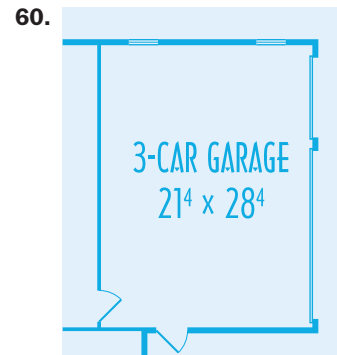

Note: 21^4 means $21\frac{4}{12}$ feet and 28^4 means $28\frac{4}{12}$ feet.

In Problems 61–64 write the addition or subtraction operation illustrated by the diagram and then add or subtract as indicated.

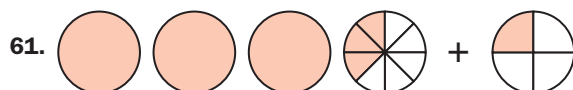

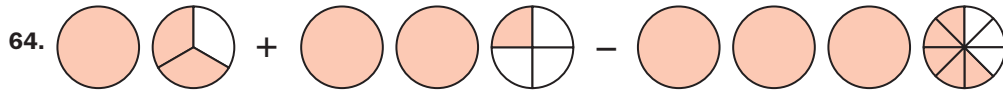

>>> Using Your Knowledge

You already know how to find the amount of base molding needed for a room if you include the door opening. In Problems 65–68, use your knowledge to find the base molding needed when you disregard the door openings. (Note that the **red** arrows mean an open space so you do not need molding for that space.) Measurements are given in feet and inches. Recall that $21^8 \times 15^0$ means that the dimensions of the room are 21 feet and 8 inches by 15 feet.

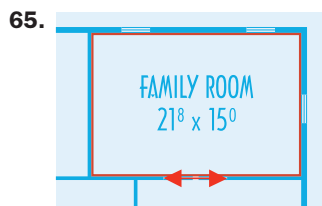

Door $3\frac{1}{2}$ feet wide

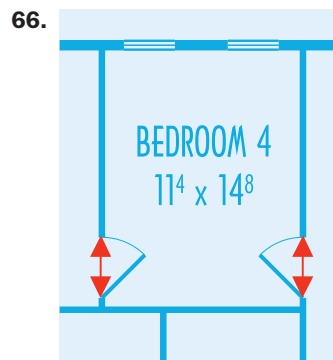

Each door $3\frac{1}{2}$ feet wide

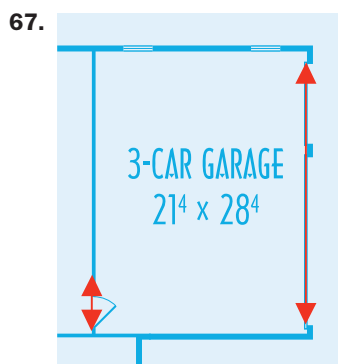

Small door $3\frac{1}{2}$ feet wide; main door 26 feet wide

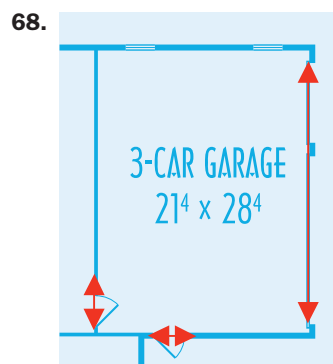

Each small door $3\frac{1}{2}$ feet wide; main door 26 feet wide

>>> Write On

69. Is the sum of two proper fractions always a proper fraction? Explain and give examples.
70. Is the sum of two mixed numbers always a mixed number? Explain and give examples.
71. Write in your own words the procedure you use to add two mixed numbers.
72. Write in your own words the procedure you use to subtract one mixed number from another.

>>> Concept Checker

Fill in the blank(s) with the correct word(s), phrase, or mathematical statement.

73. To **add** or **subtract** mixed numbers with **different denominators**, we must first find the _____ of the **denominators**.

GCD

LCD

area

perimeter

74. The **distance around** an object is the _____ of the **object**.

>>> Mastery Test

75. Add: $2\frac{3}{4} + \frac{1}{15}$

76. Add: $3\frac{3}{7} + 2\frac{1}{7}$

77. Add: $2\frac{3}{4} + 3\frac{5}{6}$

78. Subtract: $3\frac{3}{4} - 1\frac{1}{15}$

79. Perform the indicated operations:

$$2\frac{5}{9} + 3\frac{7}{10} - 4\frac{1}{12}$$

80. Find the perimeter of the rectangle:

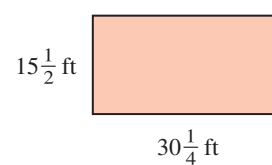

>>> Skill Checker

Perform the indicated operations.

81. $\frac{5}{18} \cdot \frac{9}{10}$

82. $\frac{3}{10} \cdot \frac{6}{28}$

83. $\frac{4}{5} \div \frac{15}{32}$

84. $\frac{10}{33} \div \frac{25}{11}$

2.7

Order of Operations and Grouping Symbols

▶ Objectives

A > Simplify expressions containing fractions and mixed numbers using the order of operations.

B > Remove grouping symbols within grouping symbols.

C > Solve applications using the concepts studied.

▶ To Succeed, Review How To . . .

1. Use the arithmetic facts (+, −, ×, ÷). (pp. 24, 37, 51, 63)
2. Evaluate an expression containing exponents. (pp. 77–78)
3. Use the order of operations studied in Section 1.8 to simplify expressions. (pp. 178–180)

▶ Getting Started



Do you exercise regularly? If you do, you probably take your pulse to ascertain what your heart rate is. To find your **ideal heart rate** (in beats per minute), subtract your age A from 205 and multiply the result by $\frac{7}{10}$. As you recall from Section 1.8, we use parentheses to indicate which operation we want to do first. In this case, we first want to subtract your age A from 205;

in symbols, $(205 - A)$.

Then, multiply the result by $\frac{7}{10}$, that is, $\frac{7}{10}(205 - A)$.

Thus, your **ideal heart rate** $= \frac{7}{10}(205 - A)$.

Now, suppose you are 25 years old. This means $A = 25$, and

$$\text{Ideal heart rate} = \frac{7}{10}(205 - 25)$$

To evaluate this last expression, we use the *order of operations* studied in Section 1.8. Thus, we do the operations inside the parentheses **first**, then multiply by $\frac{7}{10}$ like this:

$$\begin{aligned} \text{Ideal heart rate} &= \frac{7}{10}(205 - 25) \\ &= \frac{7}{10}(180) && \text{Subtract 25 from 205.} \\ &= \frac{7 \cdot 180}{10} && \text{Multiply 7 by 180.} \\ &= \frac{1260}{10} && 7 \cdot 180 = 1260 \\ &= 126 && \text{Divide by 10.} \end{aligned}$$

This means that your **ideal heart rate** is 126 beats per minute. Is there an easier way? According to the *order of operations*, you could have divided 180 by 10, obtaining 18, and multiplied the 18 by 7. The result is the same, 126.

A > Order of Operations

The order of operations we used for whole numbers (see the diagram in Section 1.8) also applies to fractions and mixed numbers. These rules are restated here for your convenience.

ORDER OF OPERATIONS (PEMDAS)

1. Do all calculations inside *parentheses* and other grouping symbols such as $()$, $[]$, $\{ \}$, and the fraction (division) bar first.
2. Evaluate all *exponential* expressions.
3. Do *multiplications* and *divisions* in order (as they occur) from left to right.
4. Do *additions* and *subtractions* in order (as they occur) from left to right.

Note that in **step 3**, **multiplication** is done **first**, if it occurs **first**. Thus $6 \cdot 3 \div 2 = 18 \div 2 = 9$. But **division** is done **first** if it occurs **first**, that is, $6 \div 3 \div 2 = 2 \div 2 = 1$. Similarly, in **step 4** **additions** are done **first** if they occur **first** but **subtractions** are done **first** if they occur **first**.

EXAMPLE 1 Using the order of operations

Simplify.

a. $\frac{1}{2} \cdot \left(\frac{2}{3}\right)^2 - \frac{1}{18}$

b. $\left(\frac{1}{2}\right)^3 + \frac{3}{4} \cdot \frac{1}{2}$

PROBLEM 1

Simplify.

a. $\frac{1}{3} \cdot \left(\frac{3}{2}\right)^2 - \frac{1}{12}$

b. $\left(\frac{1}{3}\right)^3 + \frac{2}{3} \cdot \frac{1}{9}$

Answers to PROBLEMS

1. a. $\frac{2}{3}$ b. $\frac{1}{9}$

SOLUTION 1

$$\begin{aligned} \text{a. } & \frac{1}{2} \cdot \left(\frac{2}{3}\right)^2 - \frac{1}{18} \\ &= \frac{1}{2} \cdot \left(\frac{4}{9}\right) - \frac{1}{18} \\ &= \frac{4}{18} - \frac{1}{18} \\ &= \frac{3}{18} \\ &= \frac{1}{6} \end{aligned}$$

Do exponents first $\left(\frac{2}{3}\right)^2 = \frac{4}{9}$.Do \times , \div in order from left to right $\frac{1}{2} \cdot \left(\frac{4}{9}\right) = \frac{4}{18}$.Do $+$, $-$ in order from left to right $\frac{4}{18} - \frac{1}{18} = \frac{3}{18}$.Reduce $\frac{3}{18}$ to $\frac{1}{6}$.

$$\begin{aligned} \text{b. } & \left(\frac{1}{2}\right)^3 + \frac{3}{4} \cdot \frac{1}{2} \\ &= \frac{1}{8} + \frac{3}{4} \cdot \frac{1}{2} \\ &= \frac{1}{8} + \frac{3}{8} \\ &= \frac{4}{8} \\ &= \frac{1}{2} \end{aligned}$$

Do exponents first $\left(\frac{1}{2}\right)^3 = \frac{1}{8}$.Do \times , \div in order from left to right $\frac{3}{4} \cdot \frac{1}{2} = \frac{3}{8}$.Do $+$, $-$ in order from left to right $\frac{1}{8} + \frac{3}{8} = \frac{4}{8}$.Reduce $\frac{4}{8}$ to $\frac{1}{2}$.**EXAMPLE 2** Using the order of operations

Simplify.

$$\text{a. } \frac{3}{4} \div \frac{1}{6} - \left(\frac{1}{2} + \frac{1}{5}\right)$$

$$\text{b. } 8 \div \frac{1}{2} \cdot \frac{1}{2} \cdot \frac{1}{2} + \frac{1}{3} - 1$$

SOLUTION 2

$$\begin{aligned} \text{a. } & \frac{3}{4} \div \frac{1}{6} - \left(\frac{1}{2} + \frac{1}{5}\right) \\ &= \frac{3}{4} \div \frac{1}{6} - \left(\frac{7}{10}\right) \\ &= \frac{9}{2} - \left(\frac{7}{10}\right) \\ &= \frac{38}{10} \\ &= \frac{19}{5} \\ &= 3\frac{4}{5} \end{aligned}$$

Add inside parentheses: $\left(\frac{1}{2} + \frac{1}{5}\right) = \left(\frac{5}{10} + \frac{2}{10}\right) = \left(\frac{7}{10}\right)$.Do \times , \div in order from left to right $\frac{3}{4} \div \frac{1}{6} = \frac{3}{4} \cdot \frac{6}{1} = \frac{18}{4} = \frac{9}{2}$.Do $+$, $-$ from left to right $\frac{9}{2} - \left(\frac{7}{10}\right) = \frac{45}{10} - \frac{7}{10} = \frac{38}{10}$.Reduce $\frac{38}{10}$ to $\frac{19}{5}$.

$$\text{b. } 8 \div \frac{1}{2} \cdot \frac{1}{2} \cdot \frac{1}{2} + \frac{1}{3} - 1$$

$$= \frac{8}{1} \cdot \frac{2}{1} \cdot \frac{1}{2} \cdot \frac{1}{2} + \frac{1}{3} - 1$$

Do \times , \div in order from left to right $8 \div \frac{1}{2} = \frac{8}{1} \cdot \frac{2}{1}$.

$$= \frac{16}{1} \cdot \frac{1}{2} \cdot \frac{1}{2} + \frac{1}{3} - 1$$

Do \times , \div in order from left to right $\frac{8}{1} \cdot \frac{2}{1} = \frac{16}{1}$.

$$= 4 + \frac{1}{3} - 1$$

Do \times , \div in order from left to right $\frac{16}{1} \cdot \frac{1}{2} \cdot \frac{1}{2} = \frac{16}{4} = 4$.

$$= 4\frac{1}{3} - 1$$

Do $+$, $-$ in order from left to right $4 + \frac{1}{3} = 4\frac{1}{3}$.

$$= 3\frac{1}{3}$$

Do $+$, $-$ in order from left to right $4\frac{1}{3} - 1 = 3\frac{1}{3}$.**PROBLEM 2**

Simplify.

$$\text{a. } \frac{3}{4} \div \frac{5}{6} - \left(\frac{1}{3} + \frac{1}{5}\right)$$

$$\text{b. } 27 \div \frac{1}{3} \cdot \frac{1}{3} \cdot \frac{1}{3} + \frac{1}{2} - 1$$

Answers to PROBLEMS

$$2. \text{ a. } \frac{11}{30} \quad \text{b. } 8\frac{1}{2}$$

EXAMPLE 3 Using the order of operations

Simplify.

$$\left(\frac{1}{2}\right)^3 \div \frac{1}{4} \cdot \frac{1}{2} + \frac{1}{3}\left(\frac{5}{2} - \frac{1}{2}\right) - \frac{1}{3} \cdot \frac{1}{2}$$

SOLUTION 3

$$\begin{aligned} &\left(\frac{1}{2}\right)^3 \div \frac{1}{4} \cdot \frac{1}{2} + \frac{1}{3}\left(\frac{5}{2} - \frac{1}{2}\right) - \frac{1}{3} \cdot \frac{1}{2} \\ &= \left(\frac{1}{2}\right)^3 \div \frac{1}{4} \cdot \frac{1}{2} + \frac{1}{3}(2) - \frac{1}{3} \cdot \frac{1}{2} \\ &= \frac{1}{8} \div \frac{1}{4} \cdot \frac{1}{2} + \frac{1}{3}(2) - \frac{1}{3} \cdot \frac{1}{2} \\ &= \frac{1}{2} \cdot \frac{1}{2} + \frac{1}{3}(2) - \frac{1}{3} \cdot \frac{1}{2} \\ &= \frac{1}{4} + \frac{2}{3} - \frac{1}{6} \\ &= \frac{11}{12} - \frac{1}{6} \\ &= \frac{9}{12} \\ &= \frac{3}{4} \end{aligned}$$

Do operations inside parentheses:

$$\left(\frac{5}{2} - \frac{1}{2}\right) = \left(\frac{4}{2}\right) = (2).$$

$$\text{Do exponents: } \left(\frac{1}{2}\right)^3 = \frac{1}{8}.$$

$$\text{Do divisions: } \frac{1}{8} \div \frac{1}{4} = \frac{1}{8} \cdot \frac{4}{1} = \frac{1}{2}.$$

$$\text{Do multiplications: } \frac{1}{2} \cdot \frac{1}{2} = \frac{1}{4}; \frac{1}{3}(2) = \frac{2}{3}; \frac{1}{3} \cdot \frac{1}{2} = \frac{1}{6}.$$

$$\text{Do additions: } \frac{1}{4} + \frac{2}{3} = \frac{3}{12} + \frac{8}{12} = \frac{11}{12}.$$

$$\text{Do subtractions: } \frac{11}{12} - \frac{1}{6} = \frac{11}{12} - \frac{2}{12} = \frac{9}{12}.$$

$$\text{Reduce } \frac{9}{12} \text{ to } \frac{3}{4}.$$

PROBLEM 3

Simplify.

$$\left(\frac{1}{2}\right)^3 \div \frac{1}{8} \cdot \frac{1}{2} + \frac{1}{3}\left(\frac{3}{2} - \frac{1}{2}\right) - \frac{1}{3} \cdot \frac{1}{2}$$

B > More Than One Set of Grouping Symbols

As you recall from Section 1.8, when grouping symbols occur within other grouping symbols (nested symbols), computations in the innermost grouping symbols are done first. We illustrate this in Example 4.

EXAMPLE 4 Using the order of operations

Simplify.

$$\frac{1}{5} \div 1\frac{1}{5} + \left\{ 12 \cdot \left(\frac{1}{2}\right)^2 - \left[\frac{1}{3} + \left(2\frac{1}{2} - \frac{1}{2}\right)\right] \right\}$$

SOLUTION 4

$$\begin{aligned} &\frac{1}{5} \div 1\frac{1}{5} + \left\{ 12 \cdot \left(\frac{1}{2}\right)^2 - \left[\frac{1}{3} + \left(2\frac{1}{2} - \frac{1}{2}\right)\right] \right\} \\ &= \frac{1}{5} \div 1\frac{1}{5} + \left\{ 12 \cdot \left(\frac{1}{2}\right)^2 - \left[\frac{1}{3} + (2)\right] \right\} && \text{Subtract inside parentheses: } \left(2\frac{1}{2} - \frac{1}{2}\right) = (2). \\ &= \frac{1}{5} \div 1\frac{1}{5} + \left\{ 12 \cdot \left(\frac{1}{2}\right)^2 - 2\frac{1}{3} \right\} && \text{Add inside brackets: } \left[\frac{1}{3} + (2) = 2\frac{1}{3}\right]. \\ &= \frac{1}{5} \div 1\frac{1}{5} + \left\{ 12 \cdot \left(\frac{1}{4}\right) - 2\frac{1}{3} \right\} && \text{Do exponents inside braces: } \left(\frac{1}{2}\right)^2 = \left(\frac{1}{4}\right). \\ &= \frac{1}{5} \div 1\frac{1}{5} + \left\{ 3 - 2\frac{1}{3} \right\} && \text{Multiply inside braces: } 12 \cdot \left(\frac{1}{4}\right) = \left(\frac{12}{4}\right) = 3. \\ &= \frac{1}{5} \div 1\frac{1}{5} + \left\{ \frac{2}{3} \right\} && \text{Subtract inside braces: } 3 - 2\frac{1}{3} = \frac{2}{3}. \\ &= \frac{1}{6} + \frac{2}{3} && \text{Divide: } \frac{1}{5} \div 1\frac{1}{5} = \frac{1}{5} \div \frac{6}{5} = \frac{1}{5} \cdot \frac{5}{6} = \frac{1}{6}. \\ &= \frac{5}{6} && \text{Add: } \frac{1}{6} + \frac{2}{3} = \frac{1}{6} + \frac{4}{6} = \frac{5}{6}. \end{aligned}$$

PROBLEM 4

Simplify.

$$\frac{1}{6} \div 1\frac{1}{6} + \left\{ 27 \cdot \left(\frac{1}{3}\right)^2 - \left[\frac{1}{3} + \left(2\frac{1}{3} - \frac{1}{3}\right)\right] \right\}$$

Answers to PROBLEMS

3. $\frac{2}{3}$ 4. $\frac{17}{21}$

C > Applications: Averages

Suppose you score 8, 9, and 8 on three math quizzes. What is the average for the three quizzes? Here is the rule we need:

AVERAGES

To find the **average** of a set of numbers, add the numbers and divide by the number of (elements in the set) addends.

The addends are the numbers to be added (8, 9, and 8).

Thus, to find the average of 8, 9, and 8, we add 8, 9, and 8 and divide by the number of addends, which is 3. The answer is

$$\frac{8 + 9 + 8}{3} = \frac{25}{3} = 8\frac{1}{3}$$

EXAMPLE 5 Calculating an average

Shroeder went fishing and caught four fish weighing $3\frac{1}{2}$, $5\frac{1}{4}$, $2\frac{1}{2}$, and $7\frac{1}{4}$ pounds, respectively. What is the average weight of the four fish?

SOLUTION 5 To find the average, add the weights and divide by 4.

$$\frac{3\frac{1}{2} + 5\frac{1}{4} + 2\frac{1}{2} + 7\frac{1}{4}}{4} \quad \leftarrow \text{Add these first.}$$

To simplify the calculation, add the whole parts 3, 5, 2, and 7, obtaining 17, and then the fractional parts $\frac{1}{2} + \frac{1}{4} + \frac{1}{2} + \frac{1}{4} = 1\frac{1}{2}$.

$$\begin{aligned} \text{Thus, we have: } \frac{3\frac{1}{2} + 5\frac{1}{4} + 2\frac{1}{2} + 7\frac{1}{4}}{4} &= \frac{17 + 1\frac{1}{2}}{4} = \frac{18\frac{1}{2}}{4} = \frac{37}{8} \\ &= \frac{37}{2} \cdot \frac{1}{4} = \frac{37}{8} = 4\frac{5}{8} \end{aligned}$$

This means that the average weight of the four fish is $4\frac{5}{8}$ pounds.

PROBLEM 5

Find the average weight of four fish weighing $5\frac{1}{4}$, $6\frac{1}{2}$, $4\frac{1}{4}$, and $3\frac{1}{2}$ pounds, respectively.

How can you decrease pollution? By using a more efficient car! The most efficient overall car is the Toyota Prius, the least-efficient two-seater, the Lamborghini Murcielago.

Most efficient overall

	MPG	
	City	Hwy.
 Toyota Prius	51	48

Least-Efficient Two-Seaters

Lamborghini Murcielago, 12 cyl, 6.5 L, Man(6)		
Lamborghini Murcielago Roadster, 12 cyl, 6.5 L, Man(6)	8	13

Source: <http://www.fueleconomy.gov/feg/bestworst.shtml>.

You can find the average MPG (that is, the MPG you probably will get) by taking the *average* of your miles per gallon (MPG) in the city and on the highway (Hwy.).

Answers to PROBLEMS

5. $4\frac{7}{8}$ pounds

GREEN MATH

EXAMPLE 6 Calculating average MPG for cars

- Find the average MPG for the Toyota Prius.
- Find the average MPG for the Lamborghini Murcielago.

SOLUTION 6

- To find the average MPG for the Toyota Prius, add the city MPG (51) to the Hwy. MPG (48) and take the average by dividing by 2.

$$\text{Ave. MPG} = \frac{51 + 48}{2} = \frac{99}{2} = 49\frac{1}{2} \text{ MPG}$$

Thus, the Ave. MPG for the Prius is $49\frac{1}{2}$ miles per gallon.

- To find the average MPG for the Lamborghini, add the city MPG (8) to the Hwy. MPG (13) and take the average by dividing by 2.

$$\text{Ave. MPG} = \frac{8 + 13}{2} = \frac{21}{2} = 10\frac{1}{2} \text{ MPG}$$

Thus, the Ave. MPG for the Lamborghini is $10\frac{1}{2}$ miles per gallon.

You can almost drive five times as far on a gallon of gas with the Prius as with the Murcielago, but which one would you rather drive?

PROBLEM 6

The most efficient compact car is the Honda Civic Hybrid yielding 40 MPG city and 45 MPG Hwy.

- Find the average MPG for the Honda Civic Hybrid.
- The least-efficient compact car is the Bentley Azure with 9 and 15 MPG of city and Hwy. driving, respectively. What is the average MPG for the Bentley Azure?

> Exercises 2.7



> Practice Problems > Self-Tests
> Media-rich eBooks > e-Professors > Videos

< A > < B > Order of Operations In Problems 1–25, simplify.

- $\left(\frac{1}{2}\right)^2 \cdot \frac{1}{5} + \frac{1}{6}$
- $\frac{1}{3} \cdot \left(\frac{1}{2}\right)^2 + \frac{1}{6}$
- $\frac{1}{7} + \frac{1}{3} \cdot \left(\frac{1}{2}\right)^2$
- $\frac{1}{6} + \left(\frac{1}{3}\right)^2 \cdot \frac{1}{2}$
- $\frac{1}{7} \cdot \left(\frac{1}{2}\right)^3 - \frac{1}{56}$
- $\frac{4}{9} \cdot \left(\frac{1}{2}\right)^2 - \left(\frac{1}{3}\right)^2$
- $\frac{1}{2} - \frac{1}{3} \cdot \frac{1}{5}$
- $\frac{1}{3} - \frac{1}{6} \cdot \frac{1}{5}$
- $12 \div 6 - \left(\frac{1}{3} + \frac{1}{2}\right)$
- $18 \div 9 - \left(\frac{1}{4} + \frac{1}{6}\right)$
- $\frac{1}{3} \cdot \frac{1}{4} \div \frac{1}{2} + \left(\frac{5}{6} - \frac{1}{2}\right)$
- $\frac{1}{3} \cdot \frac{1}{6} \div \frac{1}{2} + \left(\frac{4}{5} - \frac{1}{2}\right)$
- $\frac{1}{6} \div \frac{1}{3} \cdot \frac{1}{3} \cdot \frac{1}{3} + \left(\frac{1}{4} - \frac{1}{9}\right)$
- $\frac{1}{10} \div \frac{1}{2} \cdot \frac{1}{2} \cdot \frac{1}{2} + \left(\frac{2}{3} - \frac{1}{2}\right)$
- $8 \div \frac{1}{2} \cdot \frac{1}{2} \cdot \frac{1}{2} - \left(\frac{1}{3} + \frac{1}{5}\right)$
- $6 \div \frac{1}{3} \cdot \frac{1}{3} \cdot \frac{1}{3} - \left(\frac{1}{3} + \frac{1}{5}\right)$
- $\frac{1}{10} \div \frac{1}{5} \cdot \frac{1}{2} + \frac{1}{8} \left(\frac{4}{5} - \frac{1}{2}\right) + \left(\frac{1}{8} \div \frac{1}{4}\right)$
- $\frac{1}{15} \div \frac{1}{3} \cdot \frac{1}{3} + \frac{1}{2} \left(\frac{4}{5} - \frac{1}{2}\right) + \left(\frac{1}{8} \div \frac{1}{4}\right)$
- $\frac{1}{5} \div \frac{1}{3} \cdot \frac{1}{3} + \frac{1}{2} \left(\frac{1}{2} - \frac{1}{5}\right) + \left(\frac{1}{8} \div \frac{1}{4}\right)$
- $\frac{1}{20} \div \frac{1}{5} + \left\{ \frac{1}{3} \div \frac{1}{4} - \left[\frac{1}{4} + \left(\frac{1}{3} - \frac{1}{5}\right) \right] \right\}$
- $\frac{7}{30} \div \frac{1}{15} \cdot \left\{ \frac{1}{10} \div \frac{1}{20} - \left[\frac{1}{2} \cdot \frac{1}{2} + \frac{1}{2} \right] \right\}$
- $\frac{1}{30} \div \frac{1}{10} \cdot \left\{ \frac{1}{2} \div \frac{1}{4} - \left[\frac{1}{3} \cdot \frac{1}{3} + \frac{1}{3} \right] \right\}$
- $\frac{1}{4} \div \frac{1}{12} \cdot \frac{1}{6} + \left[\frac{1}{5} \left(\frac{1}{3} + \frac{1}{2}\right) - \frac{1}{6} \right] - \left(\frac{1}{3} + \frac{1}{2} \cdot \frac{1}{3}\right)$

Answers to PROBLEMS

6. a. $42\frac{1}{2}$ MPG b. 12 MPG

Applications: Green Math

26. The **green** chart shows the **original** mandated CAFE (Corporate Average Fuel Economy) MPG regulations for fuel economy of cars and light trucks sold in the United States. What is the average MPG for the **original** standards in years 2011–2015?
27. The **blue** chart shows the **revised** CAFE standards for years 2011–2015. What is the average MPG for the **revised** standards in years 2011–2015?

Year	MPG	Year	MPG
2011	27	2011	28
2012	29	2012	30
2013	30	2013	32
2014	31	2014	33
2015	32	2015	35

28. *Weight of ash* The approximate weight of one cubic foot of different varieties of ash (in pounds) is as follows:
- Black ash: 40
Green ash: $41\frac{1}{2}$
White ash: 43
- What is the average weight of one cubic foot of ash?
29. *Weight of hemlock* The approximate weight of one cubic foot of different varieties of hemlock (in pounds) is as follows:
- Eastern: 29
Western: $32\frac{1}{2}$
Mountain: $32\frac{3}{5}$
- What is the average weight of one cubic foot of hemlock?
30. *Top three box office moneymakers* The top three domestic box office films of all time and their box office gross (in millions of dollars) are:
- Avatar* (2009): $\$671\frac{7}{10}$
Titanic (1997): $600\frac{4}{5}$
The Dark Knight (2008): $\$533\frac{3}{10}$
- What is the average box office gross for these three films?
31. *Last three box office moneymakers* The last three films in the 100 top grossing domestic films and their box office gross (in millions of dollars) are:
- Armageddon* (1998): $\$201\frac{4}{5}$
Superman Returns (2006): $\$200\frac{1}{10}$
Gone with the Wind (1939): $\$198\frac{7}{10}$
- a. What is the average box office gross for these three films?
b. What is the difference between the averages for the last three films in the top 100 and the first three films (Problem 30)?
- Source: <http://boxofficemojo.com>.
32. *Hours of sleep for shift workers* According to Shiftworker Online, the average number of hours of sleep per 24-hour period for shift workers equally distributed into three shifts are as follows:
- Night shifts: $4\frac{3}{5}$
Evening shifts: $8\frac{1}{2}$
Day workers: $7\frac{1}{2}$
- What is the average number of hours of sleep for these three types of workers?
33. *Nighttime pain* Here is the reported number of nights per month with nighttime pain and sleeplessness in different age groups.
- 18–34: $6\frac{4}{5}$ nights per month
35–49: $8\frac{1}{10}$ nights per month
50 and over: $10\frac{7}{10}$ nights per month
- What is the average number of nights per month during which nighttime pain with sleeplessness occurs?
Source: Gallup Poll/National Sleep Foundation.

TV viewing The chart shows the average number of hours (per week) of TV viewing for different age groups in three Canadian cities. This will be used in Problems 34–40.

	Total Pop.	Children 2–11	Adolescents 12–17	Men 18 and over	Women 18 and over
Ontario	$20\frac{1}{10}$	$13\frac{4}{5}$	$12\frac{4}{5}$	$19\frac{4}{5}$	$23\frac{9}{10}$
Manitoba	$20\frac{9}{10}$	$14\frac{2}{5}$	$12\frac{4}{5}$	$21\frac{1}{10}$	$24\frac{9}{10}$
Saskatchewan	$20\frac{1}{2}$	$14\frac{3}{10}$	$12\frac{1}{2}$	$20\frac{1}{5}$	$25\frac{1}{10}$

Source: Statistics Canada.

Find the average number of hours per week of TV viewing for

34. The total population.
 35. Children 2–11.
 36. Adolescents 12–17.
 37. Men 18 and over.
 38. Women 18 and over.
 39. On the average, which of the groups watches the most hours?
 40. On the average, which of the groups watches the least hours?

Fish weight Can you approximate the weight of a fish (in pounds) using a ruler? You can if you use the formulas below and remember that the length L and the girth G (distance around, or perimeter) of the fish must be measured in **inches**. If you don't have a flexible ruler to go around the fish, you can approximate the girth by doubling the height of the fish.

Formulas for the weight of the fish (in pounds)

$$\text{Bass} = \frac{L^2 \cdot G}{1200}$$

$$\text{Pike} = \frac{L^3}{3500}$$

$$\text{Trout} = \frac{L \cdot G^2}{800}$$

$$\text{Walleye} = \frac{L^3}{2700}$$

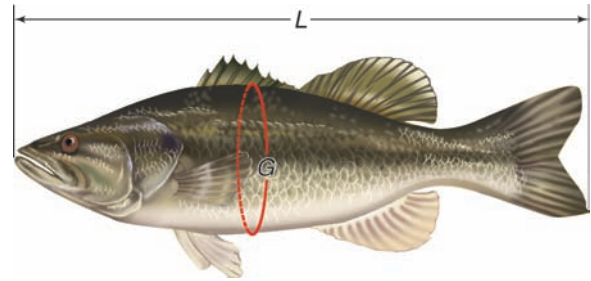

Source: <http://dnr.wi.gov>.

41. Find the approximate weight of a bass 20 inches long and with a $15\frac{1}{2}$ -inch girth.
 42. Find the approximate weight of a pike 20 inches long.
 43. Find the approximate weight of a trout 30 inches long and with a 25-inch girth.
 44. Find the approximate weight of a walleye 24 inches long.

Using Your Knowledge

Divisors, Averages, Harmony, and Equations Consider the number 6.

- a. 6 has 4 divisors: 6, 3, 2, and 1.
 b. The average of the 4 divisors of 6 is $A_6 = \frac{6 + 3 + 2 + 1}{4} = \frac{12}{4} = 3$
 c. The harmonic mean H_6 of the divisors is

$$H_6 = \frac{4}{\frac{1}{6} + \frac{1}{3} + \frac{1}{2} + \frac{1}{1}} = \frac{4}{\frac{1}{6} + \frac{2}{6} + \frac{3}{6} + \frac{6}{6}} = \frac{4}{\frac{12}{6}} = \frac{4}{1} \cdot \frac{6}{12} = 2$$

Now, drum roll here,

$$6 = A_6 \cdot H_6 = 3 \cdot 2$$

Is this true for any whole number?

45. Consider the number 8.
 a. Find the divisors of 8. (You should find 4 of them.)
 b. Find the average of the 4 divisors of 8, that is, A_8 .
 c. Find the harmonic mean of the divisors, that is, H_8 .
 d. Is it true that $A_8 \cdot H_8 = 8$?
 46. Repeat Problem 45 using the number 16. Remember, you must have $A_{16} \cdot H_{16} = 16$.

>>> Write On

47. We have studied the order of operations twice: in this section, as it applies to fractions, and in Section 1.8 as it applied to whole numbers. Write in your own words the steps you use to simplify an expression using the order of operations.
48. When simplifying $16 \cdot \frac{3}{8}$, Maria multiplied 16 by 3 and then divided by 8. Her answer was 6. Ty divided 16 by 8 *first* then multiplied the result 2, by 3.
- Write in your own words who is right, Maria or Ty?
 - Which procedure is easier, Maria's or Ty's?

>>> Concept Checker

Fill in the blank(s) with the correct word(s), phrase, or mathematical statement.

49. The **P** in **PEMDAS** means to do all calculations inside _____ and other grouping symbols.
50. The **E** in **PEMDAS** means to **evaluate** all _____ expressions.
51. The **M** in **PEMDAS** means to do all _____ and **division** in order from left to right.
52. The **D** in **PEMDAS** means to do all **multiplication** and _____ in order from left to right.
53. The **A** in **PEMDAS** means to do all _____ and **subtraction** in order from left to right.
54. The **S** in **PEMDAS** means to do all addition and _____ in order from left to right.

subtraction
addition
division
multiplication
exponential
equivalent
parentheses

>>> Mastery Test

55. Simplify: $\frac{3}{8} \div \frac{1}{12} - \left(\frac{1}{4} + \frac{1}{10}\right)$
56. Simplify: $9 \div \frac{1}{3} \cdot \frac{1}{3} \cdot \frac{1}{3} + \frac{1}{2} - 1$
57. Simplify: $\frac{1}{3} \cdot \left(\frac{3}{2}\right)^2 - \frac{1}{18}$
58. Simplify: $\left(\frac{1}{3}\right)^3 + \frac{2}{3} \cdot \frac{1}{9}$
59. Simplify: $\left(\frac{1}{3}\right)^3 \div \frac{1}{3} \cdot \frac{1}{9} + \frac{1}{2} \left(\frac{5}{3} - \frac{1}{3}\right) - \frac{1}{3} \cdot \frac{1}{2}$
60. Simplify: $\frac{1}{7} \div 1\frac{1}{7} + \left\{12 \cdot \left(\frac{1}{2}\right)^2 - \left[\frac{1}{4} + \left(2\frac{1}{2} - \frac{1}{2}\right)\right]\right\}$
61. Find the average of $2\frac{1}{2}$, $5\frac{1}{4}$, $3\frac{1}{2}$, and $4\frac{1}{4}$.

>>> Skill Checker

Solve:

62. $x + 5 = 17$

63. $x + 7 = 13$

64. $10 - x = 3$

65. $15 = 5x$

66. $24 \div x = 6$

2.8

Equations and Problem Solving

▶ Objectives

You should be able to:

- A** > Translate word sentences and phrases into mathematical equations.
- B** > Translate a given problem into a mathematical equation, then solve the equation.
- C** > Solve applications involving the concepts studied.

▶ To Succeed, Review How To . . .

1. Use the addition, subtraction, and division principles. (pp. 93–94)
2. Add, subtract, multiply, and divide fractions and mixed numbers. (pp. 157–161, 161–163, 135, 138–140)
3. Use the RSTUV procedure. (p. 95)

▶ Getting Started

In the ad shown, it is claimed that 4 out of 5 people—that is, $\frac{4}{5}$ of the people—say Big John's beans taste better. If 400 people actually made that statement, can we find how many people were surveyed? To do this, we must learn how to translate the problem from words to mathematics.



4 out of 5 people say Big John's Beans taste better.

We bet 20¢ you'll agree.

A > Translating Mathematical Equations

PROCEDURE FOR SOLVING PROBLEMS

1. Read the problem carefully and decide what is asked for (the unknown).
2. Select \square or a letter to represent this unknown.
3. Translate the problem into an equation.

$\frac{4}{5}$ of the people prefer John's beans. This is 400 people.

$\frac{4}{5} \cdot p = 400$

Diagram showing arrows from the words in the sentence above to the corresponding parts of the equation below: $\frac{4}{5}$ from "of the people", \cdot from "prefer", p from "people", and $= 400$ from "This is 400 people".

4. Use the rules studied to solve the equation.
5. Verify your answer.

How do we remember these steps? Look at the first letter in each sentence. We still call this the RSTUV method.

Read the problem.

Select the unknown.

Translate the problem.

Use the rules studied to solve.

Verify your answer.

As you can see from step 3 on the previous page, we have translated the word “of” as multiplication (\cdot) and the words “this is” as $=$. Since these and other words will be used later, we give you a dictionary so that you can translate them properly.

Mathematics Dictionary

Word or phrase	Translation
Is, is equal to, equals, the same	$=$
Of, the product, times, multiple, multiplied by	\times or \cdot
Add, more than, plus, sum, increased by, added to, more	$+$
Subtract, less than, minus, difference, decreased by, subtracted from, less	$-$
Divide, divided by, the quotient	\div
Double, twice, twice as much	$2 \times$ or $2 \cdot$
Half, half of, half as much	$\frac{1}{2} \times$ or $\frac{1}{2} \cdot$

Now let us use the dictionary to translate these phrases:

a. a number multiplied by 8

$$n \cdot 8$$

b. the sum of $\frac{1}{5}$ and a number

$$\frac{1}{5} + n$$

(You can use *any* letter in place of n .)

c. $\frac{1}{3}$ less than twice a number

$$2 \cdot n - \frac{1}{3}$$

d. a number divided by 8

$$n \div 8 \text{ or } \frac{n}{8}$$

e. $\frac{3}{4}$ of a quantity is equal to 300

$$\frac{3}{4} \cdot q = 300$$

EXAMPLE 1 Translating words into mathematical equations

Translate into mathematical equations.

- 7 more than a number is 8.
- The difference between a number and 4 is 1.
- Twice a number equals 10.

SOLUTION 1

- $n + 7 = 8$
- $n - 4 = 1$
- $2 \cdot n = 10$

PROBLEM 1

Translate into mathematical equations.

- 5 more than a number is 6.
- The difference between a number and 8 is 2.
- 3 times a number equals 12.

Answers to PROBLEMS

- a. $n + 5 = 6$ b. $n - 8 = 2$
c. $3 \cdot n = 12$

B > Solving Problems

How can we find the answers to (a), (b), and (c) in Example 1? We can solve by using the principles we studied in Section 1.9. To make things easier, we shall state a more general principle here:

PRINCIPLES TO SOLVE EQUATIONS

If c is any number, the equation $a = b$ is equivalent to:

$$\begin{aligned} a + c &= b + c && \text{(Addition principle)} \\ a - c &= b - c && \text{(Subtraction principle)} \\ a \cdot c &= b \cdot c && \text{(Multiplication principle) } (c \neq 0) \\ a \div c &= b \div c && \text{(Division principle) } (c \neq 0) \end{aligned}$$

or
$$\frac{a}{c} = \frac{b}{c}$$

Thus, to find the answer to (a), $n + 7 = 8$, we *solve* this equation using the subtraction principle.

$$\begin{aligned} n + 7 &= 8 \\ n + \underbrace{7 - 7} &= 8 - 7 && \text{Subtract 7.} \\ 0 &&& 7 - 7 = 0 \\ n &= 1 \end{aligned}$$

To solve (b):

$$\begin{aligned} n - 4 &= 1 \\ n - \underbrace{4 + 4} &= 1 + 4 && \text{Add 4.} \\ 0 &&& -4 + 4 = 4 - 4 = 0 \\ n &= 5 \end{aligned}$$

To solve (c):

$$\begin{aligned} 2 \cdot n &= 10 \\ \frac{2 \cdot n}{2} &= \frac{10}{2} && \text{Divide by 2.} \\ n &= 5 && \frac{2}{2} = 1 \text{ and } 1 \cdot n = n \end{aligned}$$

EXAMPLE 2 Translating and solving equations

Translate and solve.

- A number x increased by $\frac{1}{7}$ gives $\frac{1}{2}$. Find x .
- $\frac{1}{3}$ less than a number y is $\frac{2}{5}$. Find y .
- The quotient of z and 5 is $\frac{3}{4}$. Find z .

SOLUTION 2

a. We translate the problem as:

A number x increased by $\frac{1}{7}$ gives $\frac{1}{2}$.

$$x + \frac{1}{7} = \frac{1}{2}$$

Since $\frac{1}{7}$ is being added to x , we subtract $\frac{1}{7}$ on both sides to obtain

$$\begin{aligned} x + \frac{1}{7} - \frac{1}{7} &= \frac{1}{2} - \frac{1}{7} \\ 0 & \\ x &= \frac{1}{2} - \frac{1}{7} \end{aligned}$$

PROBLEM 2

Translate and solve.

- A number n increased by $\frac{1}{4}$ is $\frac{3}{5}$. Find n .
- $\frac{1}{3}$ less than a number m is $\frac{3}{5}$. Find m .
- The quotient of q and 7 is $\frac{3}{5}$. Find q .

Answers to PROBLEMS

2. a. $n + \frac{1}{4} = \frac{3}{5}$; $n = \frac{7}{20}$ b. $m - \frac{1}{3} = \frac{3}{5}$; $m = \frac{14}{15}$ c. $\frac{q}{7} = \frac{3}{5}$; $q = \frac{21}{5} = 4\frac{1}{5}$

The LCD of 2 and 7 is 14, so we write

$$\begin{aligned}x &= \frac{1 \cdot 7}{2 \cdot 7} - \frac{1 \cdot 2}{7 \cdot 2} \\ &= \frac{7}{14} - \frac{2}{14} = \frac{5}{14}\end{aligned}$$

b. Translating: $\frac{1}{3}$ less than a number y is $\frac{2}{5}$.

$$\begin{aligned}y - \frac{1}{3} &= \frac{2}{5} \\ y - \frac{1}{3} + \frac{1}{3} &= \frac{2}{5} + \frac{1}{3} \quad \text{Add } \frac{1}{3}. \\ 0 & \\ y &= \frac{2}{5} + \frac{1}{3}\end{aligned}$$

The LCD of 5 and 3 is 15, so we rewrite each of the fractions with a denominator of 15, obtaining

$$y = \frac{2 \cdot 3}{5 \cdot 3} + \frac{1 \cdot 5}{3 \cdot 5} = \frac{6}{15} + \frac{5}{15} = \frac{11}{15}$$

c. The quotient of z and 5 is $\frac{3}{4}$ is translated as

$$\begin{aligned}\frac{z}{5} &= \frac{3}{4} \\ 5 \cdot \frac{z}{5} &= 5 \cdot \frac{3}{4} \quad \text{Multiply by 5.} \\ z &= \frac{15}{4} = 3\frac{3}{4}\end{aligned}$$

Here are some more problems involving translations. Don't forget to use the RSTUV method.

EXAMPLE 3 Translating and solving equations

Solve:

$\frac{3}{5}$ of what number is 12?

SOLUTION 3

$$\begin{aligned}\frac{3}{5} \cdot n &= 12 \\ \frac{\frac{3}{5} \cdot n}{\frac{3}{5}} &= \frac{12}{\frac{3}{5}} \quad \text{Divide by } \frac{3}{5}.\end{aligned}$$

Thus,

$$n = \frac{12}{\frac{3}{5}} = 12 \div \frac{3}{5} = 12 \cdot \frac{5}{3} = 4 \cdot 5 = 20$$

CHECK Is $\frac{3}{5} \cdot 20 = 12$? Yes,

$$\frac{3}{5} \cdot 20 = 12$$

PROBLEM 3

$\frac{5}{6}$ of what number is 15?

EXAMPLE 4 Translating and solving equations

Solve:

What fraction of $1\frac{1}{2}$ is $2\frac{3}{4}$?

$$n \cdot 1\frac{1}{2} = 2\frac{3}{4}$$

PROBLEM 4

What fraction of $2\frac{1}{2}$ is $3\frac{1}{4}$?

(continued)

Answers to PROBLEMS

3. 18 4. $\frac{13}{10}$

SOLUTION 4

Since $1\frac{1}{2} = \frac{3}{2}$ and $2\frac{3}{4} = \frac{11}{4}$,

$$n \cdot \frac{3}{2} = \frac{11}{4}$$

Dividing by $\frac{3}{2}$,

$$\frac{n \cdot \frac{3}{2}}{\frac{3}{2}} = \frac{\frac{11}{4}}{\frac{3}{2}}$$

Thus,

$$n = \frac{11}{4} \div \frac{3}{2} = \frac{11}{4} \cdot \frac{2}{3} = \frac{11}{\cancel{4}^2} \cdot \frac{\cancel{2}^1}{3} = \frac{11}{6}$$

CHECK Is $\frac{11}{6} \times \frac{3}{2} = \frac{11}{4}$? Yes,

$$\frac{11}{\cancel{6}^2} \cdot \frac{\cancel{3}^1}{2} = \frac{11}{4}$$

EXAMPLE 5 Translating and solving equations

Find a number such that $\frac{3}{5}$ of it is $1\frac{3}{4}$.

SOLUTION 5

$$\frac{3}{5} \cdot n = 1\frac{3}{4}$$

$$\frac{3}{5} \cdot n = \frac{7}{4} \quad \text{Write } 1\frac{3}{4} \text{ as } \frac{7}{4}$$

$$\frac{\frac{3}{5} \cdot n}{\frac{3}{5}} = \frac{\frac{7}{4}}{\frac{3}{5}} \quad \text{Divide by } \frac{3}{5}.$$

Thus,

$$n = \frac{7}{4} \div \frac{3}{5} = \frac{7}{4} \cdot \frac{5}{3} = \frac{35}{12}$$

CHECK Is $\frac{3}{5} \cdot \frac{35}{12} = \frac{7}{4}$? Yes,

$$\frac{\frac{3}{5} \cdot \frac{35}{12}}{1} = \frac{7}{4}$$

PROBLEM 5

Find a number such that $\frac{2}{7}$ of it is $1\frac{1}{2}$.

EXAMPLE 6 Finding products

The product of $3\frac{1}{2}$ and $1\frac{5}{7}$ is what number?

$$\text{SOLUTION 6} \quad 3\frac{1}{2} \cdot 1\frac{5}{7} = n$$

or $\frac{7}{2} \cdot \frac{12}{7} = n$

$$6 = n$$

PROBLEM 6

The product of $2\frac{1}{4}$ and $1\frac{1}{3}$ is what number?

C > Applications Involving Equations

The ideas presented in these examples can be used to solve problems of this type: If $7\frac{1}{2}$ ounces of tomato sauce cost 15¢, what will 10 ounces cost? To solve this problem, we make up a simpler problem that we can easily solve and then use it as a model. For example, if 8 apples cost 40¢, what will 10 apples cost?

Solution 8 apples cost 40¢

1 apple costs 5¢ (This is the unit cost.)

10 apples cost $5 \times 10 = 50$ ¢

Answers to PROBLEMS

5. $\frac{21}{4}$ 6. 3

Now to solve the tomato sauce problem, we proceed similarly, using the problem on the left as a model.

8 apples cost 40¢
1 apple costs $40¢ \div 8 = 5¢$

10 apples cost $5¢ \times 10 = 50¢$

$7\frac{1}{2} = \frac{15}{2}$ ounces cost 15¢
1 ounce costs (unit cost)

$$15¢ \div \frac{15}{2} = 15 \cdot \frac{2}{15} = 2¢$$

10 ounces cost
 $2¢ \cdot 10 = 20¢$

What we have done here is to use one of the problem-solving techniques mentioned in Section 1.9: create a related problem or *model* that is easy to solve and follow that pattern to solve the given problem.

This problem can also be solved using ratios and proportions. These topics are covered in Chapter 4.

EXAMPLE 7 Cost of detergent

If 1 pint 6 ounces ($1\frac{3}{8}$ pints) of liquid detergent cost 66¢, what will 2 pints cost?

SOLUTION 7 The solution follows the model already shown.

$1\frac{3}{8}$ pints cost 66¢
1 pint costs

$$66¢ \div \frac{11}{8} = 66¢ \cdot \frac{8}{11} = 48¢ \text{ (unit cost)}$$

2 pints cost $48 \cdot 2¢ = 96¢$

PROBLEM 7

$1\frac{1}{4}$ pints of detergent cost 60¢. What will 2 pints cost?

GREEN MATH

EXAMPLE 8 Recycling aluminum to conserve oil

According to the Environmental Protection Agency (EPA), recycling $1\frac{1}{2}$ tons of aluminum cans is the equivalent of conserving about 54 barrels of oil. How many barrels of oil will be conserved if $5\frac{1}{2}$ tons of aluminum cans are recycled?

SOLUTION 8 The solution follows the model already shown.

$$1\frac{1}{2} = \frac{3}{2} \text{ tons}$$

$$54 = \frac{54}{1} \text{ barrels}$$

One ton is equivalent to

$$\frac{54}{1} \div \frac{3}{2} = \frac{54}{1} \times \frac{2}{3} = 36 \text{ barrels}$$

Thus, $5\frac{1}{2}$ tons is equivalent to

$$5\frac{1}{2} \times 36 = \frac{11}{2} \times \frac{36}{1} = 198 \text{ barrels}$$

By the way, 198 barrels of oil yields about 4000 gallons of gas!

PROBLEM 8

According to the EPA recycling $1\frac{1}{2}$ tons of aluminum cans is the equivalent of conserving about 2400 gallons of gas. How many gallons of gas will be conserved if $5\frac{1}{2}$ tons of aluminum cans are recycled?

Answers to PROBLEMS

7. 96¢ 8. 8800

Now that we are familiar with a model to help solve equations, we shall refer back to the *Getting Started* and solve the equation about the number of people who participated in a survey.

$$\frac{4}{5} \cdot p = 400$$

Divide both sides by $\frac{4}{5}$. This means

$$p = 400 \div \frac{4}{5} = 400 \cdot \frac{5}{4} = 500$$

Thus, 500 people were surveyed, which can be easily verified because $\frac{4}{5}$ of 500 is 400, that is, $\frac{4}{5} \times 500 = 400$.

Let us summarize what we have done:

- We learned to translate words into equations.
- We solved the equations using the four principles given.
- We used simple models to solve applications.

We now use the RSTUV procedure to incorporate the techniques we've just mentioned.

EXAMPLE 9 Coins

Do you know what a Sacagawea dollar is? It is a dollar coin like the one shown. So that they could be used in coin machines, these dollars were designed with the same shape and weight as a Susan B. Anthony dollar. The Sacagawea dollar consists of an alloy that is $\frac{3}{25}$ zinc, $\frac{7}{100}$ manganese, $\frac{1}{25}$ nickel, and the rest copper. What fraction of the Sacagawea dollar is copper?



SOLUTION 9 Let us use the RSTUV procedure to solve this problem. The directions are in bold, the responses are below.

- Read the problem.** Remember, you may have to read the problem several times before you go on to step 2. The question is: What fraction of the Sacagawea dollar is copper?
- Select the unknown.** Since we want to find the fraction of the Sacagawea dollar that is copper, let the unknown (what we are looking for) be c .
- Translate the problem into an equation or inequality.** Write the essential information and translate into an *equation*. When we add the fractions ($\frac{3}{25}$, $\frac{7}{100}$, $\frac{1}{25}$, and c) we want to end with one (1).

$$\begin{array}{ccccccc} \frac{3}{25} & & \frac{7}{100} & & \frac{1}{25} & & \text{the rest} \\ \text{zinc} & & \text{manganese} & & \text{nickel} & & \text{copper} \\ \frac{3}{25} & + & \frac{7}{100} & + & \frac{1}{25} & + & c = 1 \end{array}$$

PROBLEM 9

What fraction would be copper if the amount of manganese were increased to $\frac{9}{100}$?

Answers to PROBLEMS

9. $\frac{75}{100} = \frac{3}{4}$

4. Use the rules we have studied to solve the equation. To solve the equation, we have to simplify (add) first. The LCD of 25, 100, and 25 is 100, so we write all fractions with a denominator of 100.

$$\frac{3}{25} + \frac{7}{100} + \frac{1}{25} + c = 1$$

$$\frac{12}{100} + \frac{7}{100} + \frac{4}{100} + c = \frac{100}{100}$$

Add fractions.

$$\frac{23}{100} + c = \frac{100}{100}$$

Subtract $\frac{23}{100}$ from both sides.

$$c = \frac{100}{100} - \frac{23}{100} \\ = \frac{77}{100}$$

Thus, the fraction of the coin that is copper is $c = \frac{77}{100}$.

5. Verify the answer. To verify the answer, note that:

$$\begin{aligned} & \frac{3}{25} + \frac{7}{100} + \frac{1}{25} + \frac{77}{100} \\ = & \frac{12}{100} + \frac{7}{100} + \frac{4}{100} + \frac{77}{100} = \frac{100}{100} = 1 \end{aligned}$$

TRANSLATE THIS

1. 8 more than a number is 17.

2. The difference between a number and 10 is 1.

3. The difference between 10 and a number is 1.

4. A number increased by $\frac{1}{8}$ gives $\frac{1}{3}$.

5. $\frac{1}{5}$ less than a number is $\frac{2}{5}$.

The third step in the RSTUV procedure is to **TRANSLATE the information into an equation. In Problems 1–10, TRANSLATE the sentence and match the correct translation with one of the equations A–O.**

A. $n + 17 = 8$

B. $10 - n = 1$

C. $n - \frac{1}{5} = \frac{2}{5}$

D. $\frac{6}{n} = \frac{2}{5}$

E. $n - \frac{2}{5} = \frac{1}{5}$

F. $n + \frac{1}{8} = \frac{1}{3}$

G. $3\frac{1}{5}n = 1\frac{2}{3}$

H. $\frac{2}{3} = 5n$

I. $n + 8 = 17$

J. $\frac{4}{5}n = 1\frac{2}{3}$

K. $\frac{n}{6} = \frac{2}{5}$

L. $\frac{1}{5} - n = \frac{2}{5}$

M. $1\frac{2}{3}n = 3\frac{1}{5}$

N. $n - 10 = 1$

O. $\frac{2}{3}n = 5$

6. The quotient of a number and 6 is $\frac{2}{5}$.

7. The quotient of 6 and a number is $\frac{2}{5}$.

8. $\frac{2}{3}$ of a number is 5.

9. What fraction of $1\frac{2}{3}$ is $3\frac{1}{5}$?

10. Find a number so that $\frac{4}{5}$ of it is $1\frac{2}{3}$.



> Practice Problems > Self-Tests
> Media-rich eBooks > e-Professors > Videos

> Exercises 2.8

< A > Translating Mathematical Equations In Problems 1–20, translate into mathematical symbols, expressions, or equations.

- | | | |
|---|---|--------------------------|
| 1. Is | 2. Plus | 3. Of |
| 4. Is equal to | 5. Increased by | 6. Multiplied by |
| 7. Less | 8. Half of a number | 9. Twice a number |
| 10. Subtracted | 11. A number added to 5 | 12. 7 less than a number |
| 13. A number less 7 | 14. The product of $1\frac{3}{4}$ and a number | |
| 15. The quotient of $\frac{3}{4}$ and a number is 5. | 16. The quotient of a number and $\frac{3}{4}$ is 5. | |
| 17. Half of 3 times a number equals 2. | 18. Twice a number increased by 2 is $\frac{8}{3}$. | |
| 19. Half a number decreased by 4 equals $\frac{3}{2}$. | 20. A number subtracted from 8 is the same as the number. | |

< B > Solving Problems In Problems 21–40, translate and solve.

- | | |
|--|--|
| 21. A number m increased by $\frac{1}{8}$ gives $\frac{3}{7}$. Find m . | 22. A number n added to $\frac{1}{5}$ gives $\frac{3}{8}$. Find n . |
| 23. $\frac{2}{5}$ more than a number p is $1\frac{3}{4}$. Find p . | 24. $\frac{1}{5}$ less than a number x is $\frac{4}{7}$. Find x . |
| 25. y decreased by $\frac{3}{4}$ yields $\frac{4}{5}$. Find y . | 26. $\frac{3}{5}$ subtracted from z is $1\frac{7}{8}$. Find z . |
| 27. u divided by 6 gives $3\frac{1}{2}$. Find u . | 28. The quotient of r and 7 is $\frac{3}{5}$. Find r . |
| 29. Three times a number t is $2\frac{1}{5}$. Find t . | 30. Half of a number n is $1\frac{2}{3}$. Find n . |
| 31. $1\frac{1}{2}$ of what number is $7\frac{1}{2}$? | 32. $1\frac{5}{8}$ of what number is $2\frac{7}{8}$? |
| 33. What fraction of $1\frac{2}{3}$ is 4? | 34. What fraction of $2\frac{1}{2}$ is 6? |
| 35. What part of $2\frac{1}{2}$ is $6\frac{1}{4}$? | 36. What part of $1\frac{1}{3}$ is $3\frac{1}{8}$? |
| 37. $1\frac{1}{3}$ of what number is $4\frac{2}{3}$? | 38. $3\frac{2}{5}$ of what number is $4\frac{1}{4}$? |
| 39. $1\frac{1}{8}$ of $2\frac{1}{2}$ is what number? | 40. $1\frac{1}{8}$ of $2\frac{2}{3}$ is what number? |

< C > Applications Involving Equations

(Use the RSTUV procedure and create a related problem (see part c) when possible.)

- | | |
|--|---|
| 41. <i>Slicing bread</i> Laura baked a loaf of bread $22\frac{1}{2}$ inches long, then cut it into 12 big slices. How long would the loaf be if it had 16 slices of the same thickness as the 12 slices? | 42. <i>Pancake recipe</i> A recipe for $2\frac{1}{2}$ dozen pancakes calls for $\frac{3}{2}$ cups of milk. How many cups are needed to make $1\frac{1}{4}$ dozen pancakes? |
| 43. <i>Cookie recipe</i> A recipe for $2\frac{1}{2}$ dozen cookies calls for $1\frac{7}{8}$ cups of flour. How many cups of flour are needed to make $1\frac{1}{3}$ dozen cookies? | 44. <i>Making popcorn balls</i> Desi used $2\frac{2}{3}$ cups of popped popcorn to make two popcorn balls. How many cups would she need to make 5 popcorn balls? |
| 45. <i>Banquet portions</i> At a certain banquet 20 people ate 15 pounds of ham. How much ham would have been needed to feed 32 people? | 46. <i>Peat moss for rose bushes</i> Pete Moss uses 9 pounds of peat moss for his 27 rose bushes. If each bush gets an equal amount of peat, how many pounds would he need for 30 bushes? |

- 47. Running rate** A runner goes $1\frac{1}{2}$ kilometers in $4\frac{1}{2}$ minutes. At this pace how far can he go in $7\frac{1}{2}$ minutes?
- 49. Rice costs** If $3\frac{1}{4}$ pounds of rice cost 91¢, what will $2\frac{1}{2}$ pounds cost?
- 48. Product cost** If $6\frac{1}{2}$ ounces of a product cost 26¢, what will $3\frac{1}{2}$ ounces cost?
- 50. Hourly salary** If you earn \$225 for $37\frac{1}{2}$ hours of work, how much should you earn for $46\frac{1}{2}$ hours of work at the same rate of pay?

U.S. and foreign patents The graph shows the fraction of utility (new and useful) patents granted in the United States and in foreign countries and will be used in Problems 51–52.

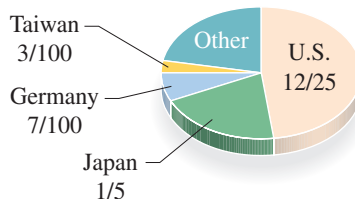

Source: U.S. Patents and Trademarks Office.

- 51.** What fraction of the patents were foreign?
- 53. Celsius to Fahrenheit temperatures** If you know the temperature C in degrees Celsius, you can convert it to degrees Fahrenheit by using the formula

$$F = 1\frac{4}{5}C + 32$$

What is the temperature in degrees Fahrenheit when it is 25 degrees Celsius?

- 55. Fahrenheit temperature and cricket chirps** If you do not have a thermometer to find the temperature F in degrees Fahrenheit, you can always use the number of chirps c a cricket makes in one minute!

The formula is

$$F = \frac{c}{4} + 39$$

If a cricket makes 120 chirps in one minute, what is the temperature?

- 52.** What fraction of the patents were granted to other countries?
- 54. Fahrenheit to Celsius temperature** On the other hand, if you want to convert from degrees Fahrenheit F , to degrees Celsius C , you can use the formula

$$C = \frac{5F - 160}{9}$$

What is the temperature in degrees Celsius when it is 68 degrees Fahrenheit?

- 56. Fahrenheit temperature and cricket chirps** There is another formula to find the temperature F in degrees Fahrenheit by counting the chirps c a cricket makes in one minute. The formula is

$$F = \frac{c - 40}{4} + 50$$

- a.** What is the temperature if a cricket makes 120 chirps in one minute?
- b.** Is the answer different from that in Exercise 55? By how much?

In Problems 57–64, follow the procedure of Example 9 to solve the problem.

- 57. Mixing cement** General-purpose cement is good for just about everything except foundations and exposed paving. This cement is made by mixing $\frac{1}{2}$ part cement, $\frac{1}{3}$ part fine aggregate, and the rest coarse aggregate.
- What fraction is cement?
 - What fraction is fine aggregate?
 - What fraction is coarse aggregate?
 - How many pounds of coarse aggregate would there be in a 50-pound bag of general-purpose cement?
- 59. Watermelon punch recipe** A recipe for Watermelon Punch calls for
- | | |
|-------------------------------|-------------------------------|
| 6 cups watermelon juice | $\frac{1}{4}$ cup raspberries |
| $\frac{1}{2}$ cup lemon juice | $\frac{1}{3}$ cup sugar |
- How many cups is that?
 - If a cup is 8 ounces, how many ounces is that?
 - If you want to make 10 servings, how many ounces are in a serving?
- 58. Best lemonade recipe** The so-called Best Lemonade Ever includes $1\frac{3}{4}$ cups of white sugar, 8 cups of water, and $1\frac{1}{2}$ cups of lemon juice.
- How many cups is that?
 - If a cup is 8 ounces, how many ounces is that?
 - If you want to make 20 servings, how many ounces are in a serving?
- 60. Volume of water** A cubic foot (ft^3) of water weighs $62\frac{1}{2}$ pounds. If the water in a container weighs 250 pounds, how many cubic feet does the water occupy?

Applications: Green Math

- 61. Recycling paper** According to the Environmental Protection Agency (EPA), recycling $1\frac{1}{2}$ tons of mixed paper is the equivalent of conserving about 270 gallons of gasoline. How many gallons of gasoline will be conserved if $5\frac{1}{2}$ tons of mixed paper is recycled?
- 62. Recycling more paper** Recycling $1\frac{1}{2}$ tons of mixed paper is the equivalent of conserving about 270 gallons of gasoline. How many gallons of gasoline will be conserved if $8\frac{1}{2}$ tons of a mixed paper is recycled?
- 63. Saving gas by recycling** According to the EPA, recycling and composting 85 million tons of Municipal Solid Waste (MSW) is equivalent to saving 11 billion gallons of gasoline. How many billion gallons of gasoline are saved if 170 million tons of MSW are recycled and composted?
- 64. Saving more gas by recycling** According to the EPA, recycling and composting 85 million tons of MSW is equivalent to saving 11 billion gallons of gasoline. How many billion gallons of gasoline are saved if 510 million tons of MSW are recycled and composted?

Using Your Knowledge

Unit Pricing You may have noticed that many supermarkets are using the idea of *unit pricing*. What this means is that each item carries a label stating its *unit price*. The *unit price* is the cost divided by the amount. In this case,

$$\frac{\text{cost}}{\text{ounces}}$$

The result is the cost per ounce. For example, if 3 ounces of tuna cost 75¢, the *unit price* is $75 \div 3 = 25\text{¢}$.

Now consider a $3\frac{1}{2}$ ounce can of tuna selling for 84¢. The *unit price* is

$$84 \div 3\frac{1}{2} = 84 \div \frac{7}{2} = 84 \cdot \frac{2}{7} = 24\text{¢}$$

That is, each ounce costs 24¢.

Now if another can of tuna containing $4\frac{1}{2}$ ounces costs 99¢, which can is the better buy? Since the first can of tuna costs 24¢ per ounce, $4\frac{1}{2}$ ounces would cost $4\frac{1}{2} \cdot 24 = \frac{9}{2} \cdot 24 = 108\text{¢}$, which is more than 99¢.

You can also solve this problem by finding the unit cost for the 99¢ can. This cost is

$$99 \div 4\frac{1}{2} = 99 \div \frac{9}{2} = 99 \cdot \frac{2}{9} = \frac{99}{1} \cdot \frac{2}{9} = 11 \cdot 2$$

or 22¢ per ounce. In either case, the second can is a better buy. Here is the summary of what we do to compare prices:

- Step 1.** Divide the price of the first item by the number of units it contains.
- Step 2.** Multiply the number obtained in step 1 by the number of units contained in the second item.
- Step 3.** Select the less expensive of the two items.

In the following problems, select the best buy.

- 65.** Sardines selling at 45¢ for $4\frac{1}{2}$ ounces
Sardines selling at 66¢ for $5\frac{1}{2}$ ounces
- 67.** Tuna selling at 70¢ for $3\frac{1}{2}$ ounces
Tuna selling at 98¢ for 4 ounces
- 69.** Lemonade concentrate selling at 33¢ for $5\frac{1}{2}$ ounces
Lemonade concentrate selling at 29¢ for 5 ounces
- 66.** Vienna sausage selling at 28¢ for $3\frac{1}{2}$ ounces
Vienna sausage selling at 33¢ for $5\frac{1}{2}$ ounces
- 68.** Orange juice concentrate selling at 36¢ for $4\frac{1}{2}$ ounces
Orange juice concentrate selling at 39¢ for 5 ounces

Write On

- 70.** Write in your own words the procedure you use to solve word problems.
- 71.** Write a list of all the strategies you use to solve word problems.
- 72.** When reading a word problem, what is the first thing you try to determine?
- 73.** How do you verify an answer in a word problem?

>>> Concept Checker

Fill in the blank(s) with the correct word(s), phrase, or mathematical statement.

- 74.** According to the **addition principle** to solve equations, if c is any number, the equation $a = b$ is equivalent to _____.
- 75.** According to the **subtraction principle** to solve equations, if c is any number, the equation $a = b$ is equivalent to _____.
- 76.** According to the **multiplication principle** to solve equations, if c is any nonzero number, the equation $a = b$ is equivalent to _____.
- 77.** According to the **division principle** to solve equations, if c is any nonzero number, the equation $a = b$ is equivalent to _____.

$$a \div c = b \div c$$

$$b + a = c + a$$

$$a + c = b + c$$

$$c - a = b - a$$

$$a - c = b - c$$

$$a \cdot b = a \cdot c$$

$$a \cdot c = b \cdot c$$

$$b \div a = c \div a$$

>>> Mastery Test

- 78.** Find a number such that $\frac{3}{5}$ of it is $3\frac{1}{4}$.
- 79.** What fraction of $1\frac{1}{2}$ is $3\frac{3}{4}$?
- 80.** Solve: $\frac{2}{3}$ of what number is 6?
- 81.** Translate into symbols:
- Three times a number equals 9.
 - The difference between a number and 5 is 2.
 - 8 more than a number is 7.
- 82.** Translate and solve:
- A number x increased by $\frac{1}{8}$ gives $\frac{1}{2}$. Find x .
 - $\frac{1}{4}$ less than a number y is $\frac{2}{5}$. Find y .
 - The quotient of z and 4 is $\frac{3}{5}$. Find z .
- 83.** The product of $2\frac{1}{2}$ and $3\frac{5}{7}$ is what number?
- 84.** One pint 8 ounces ($1\frac{1}{2}$ pints) of detergent cost 78 cents. What would 2 pints cost?
- 85.** A runner runs $1\frac{1}{2}$ miles in $8\frac{1}{2}$ minutes. How far can she run in 17 minutes?

>>> Skill Checker

- 86.** Round 185 to the nearest hundred.
- 87.** Round 185 to the nearest ten.
- 88.** Round 3285 to the nearest thousand.
- 89.** Simplify $8 \div 4 \cdot \frac{11}{2} - \left[3\left(\frac{5}{3} - \frac{1}{3}\right) + 1 \right]$.
- 90.** Simplify $4 \cdot \frac{3}{4} \div \frac{1}{3} + \left[\left(\frac{5}{8} - \frac{2}{7}\right) - \frac{1}{4} \right]$.

> Collaborative Learning

Health professionals use many ratios to detect abnormalities. Form three different groups: Library, Internet, and Other. What is the leading cause of death in the United States? Heart disease! Let each of the groups find the answers to the following questions:

- How many deaths a year are attributed to heart disease? What is the total number of annual deaths? What is the ratio of deaths attributed to heart disease to the total number of deaths? Do the answers of the groups agree? Why or why not?

There are several ratios associated with heart disease. Let us look at two of them, HDL/cholesterol and Waist/Hip.

- Let each of the groups find out what the HDL/cholesterol ratio measures. What is the recommended value of this ratio?

3. There is another noninvasive way to measure your cardiac health. This time, divide the groups into males and females. Complete the following table:

	Waist (w)	Hips (h)	Ratio w/h
Women			
Men			

For women the risk of heart disease increases when $w/h > \frac{8}{10} = \frac{4}{5} = 0.8$; for men, when $w/h > 1$.

As a matter of fact, when w/h is over 1.0 for men and 0.8 for women, the risk of heart attack or stroke is five to ten times greater than for persons with a lower ratio. ■

Research Questions

1. The earliest Egyptian and Greek fractions were usually unit fractions (having a numerator of 1). How were such fractions shown?
2. How were fractions indicated in ancient Rome?
3. It is probable that our method of writing common fractions is due essentially to the Hindus. Name the two Hindu mathematicians who wrote fractions as we do today, but without the bar.
4. The horizontal fraction bar was introduced by the Arabs and attributed to an Arab mathematician who lived around 1200. What was the name of the Arab mathematician?
5. Name the first European mathematician to use the fraction bar as it is used today.
6. Why was the diagonal fraction bar / (called a *solidus* or *virgule*) introduced and why?

Summary Chapter 2

Section	Item	Meaning	Example
2.1	Numerator Denominator	In the fraction $\frac{a}{b}$, a is the numerator. In the fraction, $\frac{a}{b}$, b is the denominator.	The numerator of $\frac{2}{3}$ is 2. The denominator of $\frac{2}{3}$ is 3.
2.1B	Proper fraction (always less than 1) Improper fraction (always greater than or equal to 1)	A fraction whose numerator is less than the denominator. A fraction whose numerator is greater than or equal to its denominator.	$\frac{3}{4}$, $\frac{9}{11}$, and $\frac{16}{17}$ are proper fractions. $\frac{17}{16}$, $\frac{19}{19}$, and $\frac{1}{1}$ are improper fractions.

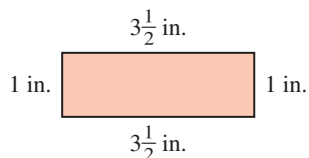
Section	Item	Meaning	Example
2.1C	Mixed number	The sum of a whole number and a proper fraction.	$5\frac{2}{3}$ and $10\frac{1}{4}$ are mixed numbers.
2.2	Equivalent fractions	Two fractions are equivalent if they are names for the same number. (They have the same value.)	$\frac{2}{4}$ and $\frac{1}{2}$ are equivalent.
2.2A	Fundamental Properties of Fractions	If a , b , and c are any numbers, then $\frac{a}{b} = \frac{a \cdot c}{b \cdot c} \quad b \neq 0, c \neq 0$ and $\frac{a}{b} = \frac{a \div c}{b \div c} \quad b \neq 0, c \neq 0$	$\frac{2}{3} = \frac{2 \cdot 4}{3 \cdot 4} = \frac{8}{12}$ $\frac{6}{9} = \frac{6 \div 3}{9 \div 3} = \frac{2}{3}$
2.2B	Reducing to lowest terms	A fraction is reduced to lowest terms when there are no common factors (except 1) in the numerator and denominator.	$\frac{140}{152}$ is not in lowest terms. $\frac{35}{38}$ is in lowest terms.
2.3A	Product of two fractions	$\frac{a}{b} \cdot \frac{c}{d} = \frac{a \cdot c}{b \cdot d}$	$\frac{3}{5} \cdot \frac{2}{7} = \frac{3 \cdot 2}{5 \cdot 7} = \frac{6}{35}$
2.3D	Reciprocal of a fraction Division of fractions	The reciprocal of $\frac{a}{b}$ is $\frac{b}{a}$. $\frac{a}{b} \div \frac{c}{d} = \frac{a}{b} \cdot \frac{d}{c}$ To divide $\frac{a}{b}$ by $\frac{c}{d}$ multiply by the reciprocal of $\frac{c}{d}$.	$\frac{4}{5}$ and $\frac{5}{4}$ are reciprocals of each other. $\frac{2}{3} \div \frac{4}{5} = \frac{2}{3} \cdot \frac{5}{4} = \frac{10}{12} = \frac{5}{6}$
2.3G	Area of a rectangle	The area A of a rectangle is found by multiplying its length L by its width W .	The area of a rectangle $5\frac{1}{2}$ in. by 3 in. is $3 \cdot 5\frac{1}{2} = 16\frac{1}{2}$ in. ² .
2.4A	LCM (least common multiple)	The LCM of two natural numbers is the <i>smallest</i> number that is a multiple of both numbers.	The LCM of 10 and 12 is 60 and the LCM of 82 and 41 is 82.
2.4B	LCD (lowest common denominator)	The LCD of two fractions is the LCM of the denominators of the fractions.	The LCD of $\frac{1}{4}$ and $\frac{1}{12}$ is 12 and the LCD of $\frac{1}{9}$ and $\frac{1}{12}$ is 36.
2.5A	Addition of fractions	$\frac{a}{b} + \frac{c}{b} = \frac{a+c}{b}$	$\frac{3}{7} + \frac{2}{7} = \frac{5}{7}$
2.5C	LCD of three fractions	The smallest number that is a multiple of all the denominators.	The LCD of $\frac{2}{5}$ and $\frac{3}{4}$ and $\frac{1}{10}$ is 20.
2.5D	Subtraction of fractions	$\frac{a}{b} - \frac{c}{b} = \frac{a-c}{b}$	$\frac{3}{7} - \frac{2}{7} = \frac{1}{7}$
2.6E	Perimeter	The distance around an object.	The perimeter of the rectangle is 9 inches. 

(continued)

Section	Item	Meaning	Example
2.7A	Order of operations PEMDAS	The order of operations is P (calculations inside parentheses) E (exponential expressions) M (multiplications) D (divisions) A (additions) S (subtractions)	To evaluate $3 \cdot 2 \div 6 + (2 + 4) - 2^2$ P: $3 \cdot 2 \div 6 + (6) - 2^2$ E: $3 \cdot 2 \div 6 + (6) - 4$ M: $6 \div 6 + (6) - 4$ D: $1 + (6) - 4$ A: $7 - 4$ S: 3
2.8B	Equivalent equations Principles to solve equations	Each of the following equations is equivalent to $a = b$ (c any number): $a + c = b + c$ $a - c = b - c$ $a \cdot c = b \cdot c$ (c not 0) $a \div c = b \div c$ (c not 0)	

Review Exercises Chapter 2

(If you need help with these exercises, look in the section indicated in brackets.)

1. < 2.1B > Classify as a proper or improper fraction.

- a. $\frac{9}{11}$ b. $\frac{0}{8}$ c. $\frac{3}{3}$
d. $\frac{5}{8}$ e. $\frac{11}{11}$

3. < 2.1D > Write as an improper fraction.

- a. $4\frac{1}{2}$ b. $3\frac{1}{9}$ c. $4\frac{2}{5}$
d. $8\frac{3}{14}$ e. $7\frac{7}{8}$

5. < 2.2A > Find each missing number.

- a. $\frac{4}{3} = \frac{?}{6}$ b. $\frac{3}{5} = \frac{?}{25}$ c. $\frac{8}{9} = \frac{?}{27}$
d. $\frac{14}{21} = \frac{?}{42}$ e. $\frac{3}{9} = \frac{?}{54}$

7. < 2.2B > Reduce to lowest terms.

- a. $\frac{4}{8}$ b. $\frac{6}{9}$ c. $\frac{14}{35}$
d. $\frac{8}{28}$ e. $\frac{10}{95}$

2. < 2.1C > Write as a mixed number.

- a. $\frac{22}{7}$ b. $\frac{18}{7}$ c. $\frac{29}{3}$
d. $\frac{14}{4}$ e. $\frac{19}{11}$

4. < 2.1E > The price of a stock is \$80 per share. Find the P/E ratio of the stock if its earnings per share are

- a. \$10 b. \$8 c. \$20
d. \$40 e. \$16

6. < 2.2A > Find each missing number.

- a. $\frac{6}{21} = \frac{2}{?}$ b. $\frac{8}{10} = \frac{4}{?}$ c. $\frac{18}{24} = \frac{6}{?}$
d. $\frac{24}{48} = \frac{4}{?}$ e. $\frac{18}{30} = \frac{6}{?}$

8. < 2.2B >

- a. Find the GCF of 12 and 36 and reduce $\frac{12}{36}$.
b. Find the GCF of 10 and 50 and reduce $\frac{10}{50}$.
c. Find the GCF of 18 and 45 and reduce $\frac{18}{45}$.
d. Find the GCF of 28 and 42 and reduce $\frac{28}{42}$.
e. Find the GCF of 51 and 34 and reduce $\frac{51}{34}$.

9. < 2.3A > Multiply (reduce answers to lowest terms).
- a. $\frac{1}{3} \cdot \frac{2}{7}$ b. $\frac{2}{5} \cdot \frac{5}{9}$
- c. $\frac{3}{7} \cdot \frac{7}{9}$ d. $\frac{4}{5} \cdot \frac{15}{8}$
- e. $\frac{7}{8} \cdot \frac{8}{7}$
10. < 2.3B > Multiply (reduce answers to lowest terms).
- a. $\frac{4}{7} \cdot 3\frac{1}{6}$ b. $\frac{3}{5} \cdot 3\frac{1}{3}$
- c. $\frac{6}{7} \cdot 1\frac{3}{4}$ d. $\frac{9}{10} \cdot 2\frac{1}{4}$
- e. $\frac{6}{7} \cdot 4\frac{2}{3}$
11. < 2.3C > Multiply.
- a. $(\frac{2}{5})^2 \cdot \frac{5}{6}$ b. $(\frac{3}{2})^2 \cdot \frac{4}{9}$
- c. $(\frac{3}{2})^2 \cdot \frac{8}{27}$ d. $(\frac{3}{2})^2 \cdot \frac{14}{27}$
- e. $(\frac{3}{2})^2 \cdot \frac{8}{9}$
12. < 2.3D > Divide (reduce answers to lowest terms).
- a. $\frac{3}{4} \div \frac{6}{7}$ b. $\frac{3}{8} \div \frac{6}{7}$
- c. $\frac{4}{5} \div \frac{5}{9}$ d. $\frac{5}{3} \div \frac{7}{9}$
- e. $\frac{6}{7} \div \frac{12}{7}$
13. < 2.3E > Divide (reduce answers to lowest terms).
- a. $2\frac{1}{4} \div \frac{4}{5}$ b. $3\frac{1}{7} \div \frac{7}{8}$
- c. $6\frac{1}{2} \div \frac{4}{13}$ d. $1\frac{1}{9} \div \frac{20}{27}$
- e. $4\frac{1}{7} \div \frac{14}{15}$
14. < 2.3E > Divide (reduce answers to lowest terms).
- a. $\frac{3}{5} \div 1\frac{1}{5}$ b. $\frac{4}{7} \div 2\frac{3}{7}$
- c. $\frac{3}{5} \div 3\frac{1}{5}$ d. $\frac{1}{7} \div 2\frac{1}{2}$
- e. $\frac{2}{9} \div 3\frac{1}{8}$
15. < 2.3G > Find the area of a room with dimensions.
- a. $3\frac{1}{3}$ yards by $4\frac{2}{3}$ yards
- b. $3\frac{1}{2}$ yards by $4\frac{1}{2}$ yards
- c. $3\frac{1}{3}$ yards by $4\frac{1}{2}$ yards
- d. $3\frac{1}{2}$ yards by $4\frac{1}{3}$ yards
- e. $4\frac{1}{2}$ yards by $5\frac{1}{2}$ yards
16. < 2.4A > Find the LCM of each group of numbers.
- a. 8 and 12
- b. 15 and 6
- c. 18 and 12
- d. 20 and 24
- e. 54 and 180
17. < 2.4A > Find the LCM of
- a. 11 and 33
- b. 17 and 34
- c. 57 and 19
- d. 40 and 10
- e. 92 and 23
18. < 2.4B > Find the LCD and use it to write the fractions with the LCD as denominator.
- a. $\frac{7}{12}$ and $\frac{3}{16}$
- b. $\frac{2}{15}$ and $\frac{5}{9}$
- c. $\frac{5}{16}$ and $\frac{5}{18}$
- d. $\frac{3}{7}$ and $\frac{4}{5}$
- e. $\frac{5}{9}$ and $\frac{4}{15}$
19. < 2.4B > Find the LCD and use it to write the fractions with the LCD as denominator.
- a. $\frac{3}{4}$, $\frac{1}{2}$, and $\frac{5}{6}$
- b. $\frac{5}{12}$, $\frac{1}{9}$, and $\frac{3}{8}$
- c. $\frac{13}{16}$, $\frac{1}{18}$, and $\frac{11}{12}$
- d. $\frac{1}{10}$, $\frac{3}{8}$, and $\frac{1}{12}$
- e. $\frac{1}{5}$, $\frac{4}{9}$, and $\frac{1}{8}$
20. < 2.4C > Fill in the blank with < or > to make the resulting inequality true.
- a. $\frac{1}{3}$ _____ $\frac{3}{10}$
- b. $\frac{2}{3}$ _____ $\frac{3}{7}$
- c. $\frac{4}{5}$ _____ $\frac{5}{7}$
- d. $\frac{2}{9}$ _____ $\frac{3}{7}$
- e. $\frac{3}{8}$ _____ $\frac{5}{32}$

21. < 2.5A > Add (reduce answers to lowest terms).

a. $\frac{1}{5} + \frac{2}{5}$

b. $\frac{2}{3} + \frac{1}{3}$

c. $\frac{3}{7} + \frac{1}{7}$

d. $\frac{2}{9} + \frac{1}{9}$

e. $\frac{7}{2} + \frac{9}{2}$

23. < 2.5B > Find the LCD and add (reduce answers to lowest terms).

a. $\frac{15}{4} + \frac{16}{3}$

b. $\frac{7}{2} + \frac{5}{3}$

c. $\frac{17}{4} + \frac{33}{16}$

d. $\frac{19}{9} + \frac{13}{3}$

e. $\frac{9}{8} + \frac{19}{9}$

25. < 2.5D > Find the LCD and subtract.

a. $\frac{7}{8} - \frac{3}{4}$

b. $\frac{11}{12} - \frac{7}{18}$

c. $\frac{7}{12} - \frac{5}{16}$

d. $\frac{5}{7} - \frac{3}{5}$

e. $\frac{16}{27} - \frac{5}{24}$

27. < 2.6B > Add.

a. $4\frac{1}{5} + 3\frac{1}{6}$

b. $2\frac{1}{3} + 3\frac{1}{12}$

c. $4\frac{4}{7} + 3\frac{2}{8}$

d. $5\frac{1}{3} + 2\frac{1}{9}$

e. $3\frac{5}{8} + 5\frac{3}{12}$

22. < 2.5B > Find the LCD and add (reduce answers to lowest terms).

a. $\frac{1}{3} + \frac{5}{6}$

b. $\frac{1}{5} + \frac{1}{9}$

c. $\frac{3}{7} + \frac{5}{6}$

d. $\frac{1}{6} + \frac{9}{20}$

e. $\frac{2}{7} + \frac{3}{15}$

24. < 2.5D > Find the LCD of the fractions and then find each of the following.

a. $\frac{5}{7} + \frac{1}{6} - \frac{1}{12}$

b. $\frac{3}{4} + \frac{1}{8} - \frac{1}{12}$

c. $\frac{5}{8} + \frac{3}{4} - \frac{1}{16}$

d. $\frac{4}{5} + \frac{1}{3} - \frac{2}{15}$

e. $\frac{2}{3} + \frac{3}{4} - \frac{1}{12}$

26. < 2.5E > Student music preferences

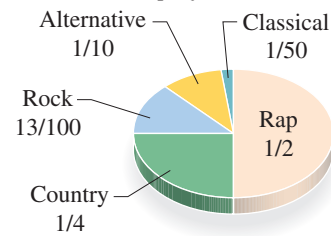

What fraction of the students prefer:

- Rap or country?
- Rock or country?
- Alternative or rock?
- Classical or rap?
- Alternative or classical?

28a. < 2.6C > Subtract.

a. $2\frac{7}{8} - 2\frac{2}{3}$

b. $3\frac{1}{3} - 1\frac{3}{5}$

c. $3\frac{1}{5} - 2\frac{1}{3}$

d. $4\frac{3}{5} - 3\frac{5}{8}$

e. $1\frac{7}{8} - 1\frac{5}{9}$

28b. < 2.6D > Add and subtract as indicated.

- $2\frac{5}{9} + 3\frac{1}{8} - 2\frac{1}{10}$
- $3\frac{5}{9} + 3\frac{1}{6} - 2\frac{1}{10}$
- $4\frac{5}{9} + 3\frac{1}{12} - 2\frac{1}{8}$
- $5\frac{5}{9} + 3\frac{1}{12} - 2\frac{1}{6}$
- $6\frac{5}{9} + 3\frac{1}{8} - 2\frac{1}{6}$

30. < 2.7A > Simplify:

- $\frac{1}{2} \cdot \left(\frac{2}{3}\right)^2 - \frac{1}{9}$
- $\frac{1}{3} \cdot \left(\frac{3}{4}\right)^2 - \frac{1}{16}$
- $\frac{1}{5} \cdot \left(\frac{5}{6}\right)^2 - \frac{1}{36}$
- $\frac{1}{6} \cdot \left(\frac{6}{7}\right)^2 - \frac{1}{49}$
- $\frac{1}{7} \cdot \left(\frac{7}{8}\right)^2 - \frac{1}{64}$

32. < 2.7A > Simplify:

- $\left(\frac{1}{2}\right)^3 \div \frac{1}{3} \cdot \frac{1}{4} + \frac{1}{3} \left(\frac{7}{2} - \frac{1}{2}\right) - \frac{1}{3} \cdot \frac{1}{2}$
- $\left(\frac{1}{2}\right)^3 \div \frac{1}{3} \cdot \frac{1}{4} + \frac{1}{3} \left(\frac{9}{2} - \frac{1}{2}\right) - \frac{1}{3} \cdot \frac{1}{2}$
- $\left(\frac{1}{2}\right)^3 \div \frac{1}{3} \cdot \frac{1}{4} + \frac{1}{3} \left(\frac{5}{2} - \frac{1}{2}\right) - \frac{1}{3} \cdot \frac{1}{2}$
- $\left(\frac{1}{2}\right)^3 \div \frac{1}{8} \cdot \frac{1}{2} + \frac{1}{3} \left(\frac{3}{2} - \frac{1}{2}\right) - \frac{1}{3} \cdot \frac{1}{2}$
- $\left(\frac{1}{2}\right)^3 \div \frac{1}{4} \cdot \frac{1}{2} + \frac{1}{3} \left(\frac{11}{2} - \frac{1}{2}\right) - \frac{1}{3} \cdot \frac{1}{2}$

34. < 2.7C > Find the average weight of four fish weighing

- $3\frac{1}{2}$, $4\frac{1}{4}$, $2\frac{1}{2}$, and $7\frac{1}{4}$ pounds.
- $4\frac{1}{2}$, $5\frac{1}{4}$, $3\frac{1}{2}$, and $8\frac{1}{4}$ pounds.
- $5\frac{1}{2}$, $6\frac{1}{4}$, $4\frac{1}{2}$, and $9\frac{1}{4}$ pounds.
- $6\frac{1}{2}$, $7\frac{1}{4}$, $5\frac{1}{2}$, and $10\frac{1}{4}$ pounds.
- $7\frac{1}{2}$, $8\frac{1}{4}$, $6\frac{1}{2}$, and $11\frac{1}{4}$ pounds.

29. < 2.6E > Find the perimeter of a room whose dimensions are:

- $4\frac{1}{4}$ yards by $5\frac{1}{2}$ yards
- $3\frac{1}{2}$ yards by $4\frac{1}{3}$ yards
- $4\frac{1}{3}$ yards by $5\frac{1}{2}$ yards
- $3\frac{1}{2}$ yards by $5\frac{1}{3}$ yards
- $3\frac{1}{6}$ yards by $2\frac{5}{6}$ yards

31. < 2.7A > Simplify:

- $4 \div \frac{1}{2} \cdot \frac{1}{2} \cdot \frac{1}{2} + \frac{1}{3} - 2$
- $6 \div \frac{1}{2} \cdot \frac{1}{2} \cdot \frac{1}{2} + \frac{1}{3} - 3$
- $8 \div \frac{1}{2} \cdot \frac{1}{2} \cdot \frac{1}{2} + \frac{1}{3} - 4$
- $10 \div \frac{1}{2} \cdot \frac{1}{2} \cdot \frac{1}{2} + \frac{1}{3} - 5$
- $12 \div \frac{1}{2} \cdot \frac{1}{2} \cdot \frac{1}{2} + \frac{1}{3} - 6$

33. < 2.7B > Simplify:

- $\frac{1}{6} \div 1\frac{1}{6} + \left\{ 16 \cdot \left(\frac{1}{2}\right)^2 - \left[\frac{1}{3} + \left(3\frac{1}{2} - \frac{1}{2}\right)\right] \right\}$
- $\frac{1}{5} \div 1\frac{1}{5} + \left\{ 20 \cdot \left(\frac{1}{2}\right)^2 - \left[\frac{1}{3} + \left(4\frac{1}{2} - \frac{1}{2}\right)\right] \right\}$
- $\frac{1}{4} \div 1\frac{1}{4} + \left\{ 24 \cdot \left(\frac{1}{2}\right)^2 - \left[\frac{1}{3} + \left(5\frac{1}{2} - \frac{1}{2}\right)\right] \right\}$
- $\frac{1}{3} \div 1\frac{1}{3} + \left\{ 28 \cdot \left(\frac{1}{2}\right)^2 - \left[\frac{1}{3} + \left(6\frac{1}{2} - \frac{1}{2}\right)\right] \right\}$
- $\frac{1}{2} \div 1\frac{1}{2} + \left\{ 32 \cdot \left(\frac{1}{2}\right)^2 - \left[\frac{1}{3} + \left(7\frac{1}{2} - \frac{1}{2}\right)\right] \right\}$

35. < 2.8A > Translate into mathematical equations.

- 8 more than a number is 10.
- The difference between a number and 5 is 1.
- Twice a number equals 12.
- A number divided by 2 is 8.
- The quotient of a number and 7 is 3.

36. < 2.8B > Translate and solve.

- a. A number p increased by $\frac{1}{6}$ gives $\frac{1}{3}$. Find p .
- b. A number q increased by $\frac{1}{5}$ gives $\frac{1}{4}$. Find q .
- c. A number r increased by $\frac{1}{4}$ gives $\frac{2}{5}$. Find r .
- d. A number s increased by $\frac{1}{3}$ gives $\frac{5}{6}$. Find s .
- e. A number t increased by $\frac{1}{2}$ gives $\frac{6}{7}$. Find t .

38. < 2.8B > Translate and solve.

- a. The quotient of v and 3 is $\frac{2}{7}$. Find v .
- b. The quotient of v and 4 is $\frac{3}{7}$. Find v .
- c. The quotient of v and 5 is $\frac{4}{7}$. Find v .
- d. The quotient of v and 6 is $\frac{5}{7}$. Find v .
- e. The quotient of v and 7 is $\frac{6}{7}$. Find v .

40. < 2.8C > An alloy consists of four metals A, B, C, and D. What fraction of the alloy is D when A, B, and C are, respectively,

- a. $\frac{3}{25}, \frac{7}{100}, \frac{1}{25}$
- b. $\frac{6}{25}, \frac{7}{100}, \frac{2}{25}$
- c. $\frac{7}{25}, \frac{7}{100}, \frac{3}{25}$
- d. $\frac{8}{25}, \frac{7}{100}, \frac{4}{25}$
- e. $\frac{9}{25}, \frac{7}{100}, \frac{6}{25}$

37. < 2.8B > Translate and solve.

- a. $\frac{1}{6}$ less than a number r is $\frac{2}{7}$. Find r .
- b. $\frac{1}{5}$ less than a number s is $\frac{3}{7}$. Find s .
- c. $\frac{1}{4}$ less than a number t is $\frac{4}{7}$. Find t .
- d. $\frac{1}{3}$ less than a number u is $\frac{5}{7}$. Find u .
- e. $\frac{1}{2}$ less than a number v is $\frac{6}{7}$. Find v .

39. < 2.8B > Find the number.

- a. $\frac{1}{2}$ of what number is 8?
- b. $\frac{2}{3}$ of what number is 4?
- c. $\frac{3}{5}$ of what number is 27?
- d. $\frac{2}{7}$ of what number is 14?
- e. $\frac{6}{5}$ of what number is 12?

Practice Test Chapter 2

(Answers on page 206)

Visit www.mhhe.com/bello to view helpful videos that provide step-by-step solutions to several of the problems below.

- Classify as a proper or improper fraction.
 - $\frac{3}{4}$
 - $\frac{5}{3}$
 - $\frac{8}{8}$
- Write $2\frac{3}{7}$ as an improper fraction.
- Fill in the blank: $\frac{4}{7} = \frac{\square}{21}$
- Reduce $\frac{14}{35}$ to lowest terms.
- Multiply: $\frac{1}{6} \cdot \frac{5}{7}$
- Multiply: $(\frac{4}{3})^2 \cdot \frac{1}{16}$
- Divide: $2\frac{1}{2} \div \frac{4}{3}$
- Find the area of a room whose dimensions are $4\frac{1}{3}$ yards by $5\frac{2}{3}$ yards.
- Find the LCM of 17 and 51.
- Find the LCD of $\frac{7}{10}$, $\frac{3}{4}$, and $\frac{5}{8}$ and write $\frac{7}{10}$, $\frac{3}{4}$, and $\frac{5}{8}$ as equivalent fractions with the LCD as denominator.
- Add: $\frac{3}{7} + \frac{2}{7}$
- Find the LCD and add: $\frac{5}{3} + \frac{22}{7}$
- Find the LCD and subtract: $\frac{7}{15} - \frac{3}{10}$
- Add: $3\frac{4}{5} + 2\frac{2}{3}$
- Subtract:
 - $3\frac{5}{6} - 2\frac{1}{5}$
 - $2\frac{2}{7} - 1\frac{1}{4}$
- Find the perimeter of a room whose dimensions are $3\frac{1}{3}$ yards by $5\frac{2}{3}$ yards.
- Simplify: $\frac{1}{3} \cdot (\frac{3}{4})^2 - \frac{1}{16}$
- Simplify: $6 \div \frac{1}{2} \cdot \frac{1}{2} \cdot \frac{1}{2} + \frac{1}{3} - 2$
- Simplify: $(\frac{1}{3})^3 \div \frac{1}{3} \cdot \frac{1}{4} + \frac{1}{3} (\frac{5}{2} - \frac{1}{2}) - \frac{1}{3} \cdot \frac{1}{2}$
- Simplify: $\frac{1}{3} \div 1\frac{1}{3} + \left\{ 12 \cdot (\frac{1}{2})^2 - \left[\frac{1}{3} + (2\frac{1}{2} - \frac{1}{2}) \right] \right\}$
- Translate and solve: $\frac{1}{7}$ less than a number y is $\frac{2}{5}$. What is y ?
- What fraction of $1\frac{2}{3}$ is $2\frac{1}{9}$?
- The product of $1\frac{2}{3}$ and $2\frac{1}{5}$ is what number?
- Write $\frac{23}{6}$ as a mixed number.
- The price of a stock is \$60 per share and its earnings per share are \$5. What is the P/E ratio of the stock?
- Fill in the blank: $\frac{2}{5} = \frac{6}{\square}$
- Find the GCF of 32 and 48, then reduce $\frac{32}{48}$.
- Multiply: $\frac{3}{7} \cdot 2\frac{1}{6}$
- Divide: $\frac{2}{3} \div \frac{4}{7}$
- Divide: $\frac{3}{2} \div 1\frac{1}{4}$
- Find the LCM of 15 and 20.
- Find the LCD of $\frac{7}{8}$ and $\frac{5}{12}$ and write $\frac{7}{8}$ and $\frac{5}{12}$ as equivalent fractions with the LCD as denominator.
- Fill in the blank with $<$ or $>$ to make the resulting inequality true: $\frac{2}{3} \underline{\hspace{1cm}} \frac{4}{7}$
- Find the LCD and add: $\frac{2}{3} + \frac{1}{5}$
- Find the LCD of $\frac{6}{7}$, $\frac{5}{6}$, and $\frac{1}{12}$ and then find: $\frac{6}{7} + \frac{5}{6} - \frac{1}{12}$
- Here are the favorite sports for a group of students.

Favorite Sports

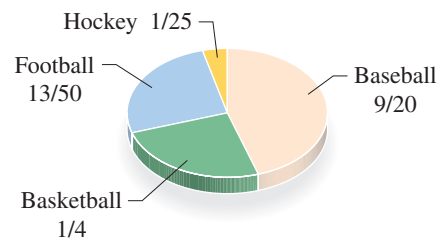

What fraction of the students chose either baseball or basketball?

- Pedro went fishing and caught 4 fish weighing $3\frac{1}{2}$, $5\frac{1}{4}$, $2\frac{1}{2}$, and $6\frac{1}{4}$ pounds, respectively. What is the average weight of the 4 fish?
- $\frac{3}{5}$ of what number is 9?
- Find a number such that $\frac{4}{5}$ of it is $1\frac{1}{3}$.
- A proposed dollar coin is made of an alloy consisting of $\frac{4}{25}$ zinc, $\frac{7}{100}$ manganese, $\frac{1}{25}$ nickel, and the rest copper. What fraction of the coin is copper?

Answers to Practice Test Chapter 2

Answer	If You Missed		Review	
	Question	Section	Examples	Page
1. a. Proper b. Improper c. Improper	1	2.1	2	116
2. $3\frac{5}{6}$	2	2.1	3	117
3. $\frac{17}{7}$	3	2.1	4	117
4. 12	4	2.1	5, 6, 7, 8	118–119
5. 12	5	2.2	1	126
6. 15	6	2.2	2	127
7. $\frac{2}{5}$	7	2.2	3	128–129
8. GCF 16; $\frac{32}{48} = \frac{2}{3}$	8	2.2	1, 2, 3	126–129
9. $\frac{5}{42}$	9	2.3	1a	135
10. $\frac{13}{14}$	10	2.3	2a	136
11. $\frac{1}{9}$	11	2.3	4	138
12. $\frac{7}{6} = 1\frac{1}{6}$	12	2.3	5	140
13. $\frac{15}{8} = 1\frac{7}{8}$	13	2.3	6a	140
14. $\frac{6}{5} = 1\frac{1}{5}$	14	2.3	6b	140
15. $\frac{221}{9} = 24\frac{5}{9}$ square yards	15	2.3	9, 10	141–142
16. 60	16	2.4	1–3	148
17. 51	17	2.4	4	148
18. LCD 24; $\frac{21}{24}, \frac{10}{24}$	18	2.4	5–7	149–151
19. LCD 40; $\frac{28}{40}, \frac{30}{40}, \frac{25}{40}$	19	2.4	8	152
20. >	20	2.4	9	153
21. $\frac{5}{7}$	21	2.5	1	158
22. LCD 15; $\frac{13}{15}$	22	2.5	2	159
23. LCD 21; $\frac{101}{21} = 4\frac{17}{21}$	23	2.5	3	160
24. LCD 84; $\frac{45}{28} = 1\frac{17}{28}$	24	2.5	5, 7	161–163
25. LCD 30; $\frac{1}{6}$	25	2.5	6	161–162
26. $\frac{14}{20} = \frac{7}{10}$	26	2.5	8	163
27. $\frac{97}{15} = 6\frac{7}{15}$	27	2.6	1, 2, 3	169–170
28. a. $\frac{49}{30} = 1\frac{19}{30}$ b. $1\frac{1}{28}$	28a, b	2.6	4	170
29. 18 yards	29	2.6	6	173
30. $\frac{1}{8}$	30	2.7	1	178–179
31. $\frac{4}{3} = 1\frac{1}{3}$	31	2.7	2	179
32. $\frac{19}{36}$	32	2.7	3	180
33. $\frac{11}{12}$	33	2.7	4	180
34. $4\frac{3}{8}$ pounds	34	2.7	5	181
35. $y - \frac{1}{7} = \frac{2}{5}$; $y = \frac{19}{35}$	35	2.8	2	188
36. 15	36	2.8	3	189
37. $\frac{19}{15} = 1\frac{4}{15}$	37	2.8	4	189–190
38. $\frac{5}{3} = 1\frac{2}{3}$	38	2.8	5	190
39. $\frac{11}{3} = 3\frac{2}{3}$	39	2.8	6	190
40. $\frac{73}{100}$	40	2.8	7, 8, 9	191–192

› Cumulative Review Chapters 1–2

1. Write 438 in expanded form.
2. Write $900 + 80 + 4$ in standard form.
3. Write the word name for 74,008.
4. Write six thousand seven hundred ten in standard form.
5. Round 8649 to the nearest hundred.
6. Add: $903 + 2776$
7. Subtract: $652 - 498$
8. Multiply: 137×319
9. Betty makes loan payments of \$310 each month for 12 months. What is the total amount of money paid?
10. Divide: $26\overline{)889}$
11. Write the prime factors of 24.
12. Write 180 as a product of primes.
13. Multiply: $2^3 \times 4 \times 7^0$
14. Simplify: $36 \div 6 \cdot 6 + 8 - 4$
15. Solve for m : $26 = m + 3$
16. Solve for x : $21 = 7x$
17. Classify $\frac{2}{3}$ as a proper or improper fraction.
18. Write $\frac{11}{2}$ as a mixed number.
19. Write $2\frac{1}{4}$ as an improper fraction.
20. Fill in the blank: $\frac{2}{3} = \frac{\square}{21}$
21. Fill in the blank: $\frac{2}{3} = \frac{18}{\square}$
22. Reduce $\frac{10}{12}$ to lowest terms.
23. Insert $=$, $<$, or $>$ to make a true statement:
 $\frac{3}{4}$ — $\frac{5}{6}$
24. Multiply: $\frac{1}{2} \cdot 6\frac{1}{3}$
25. Multiply: $(\frac{7}{6})^2 \cdot \frac{1}{49}$
26. Divide: $\frac{6}{7} \div 1\frac{1}{3}$
27. Find the LCD and add: $7\frac{1}{3} + 9\frac{3}{10}$
28. Subtract: $8\frac{1}{7} - 1\frac{8}{9}$
29. Translate and solve: $\frac{6}{7}$ less than a number z is $\frac{4}{9}$. What is z ?
30. Find a number such that $\frac{9}{10}$ of it is $5\frac{1}{5}$.
31. $3\frac{1}{2}$ pounds of sugar cost 49 cents. How much will 8 pounds cost?
32. Find the perimeter of a room whose dimensions are $4\frac{1}{3}$ by $6\frac{2}{3}$ yards.
33. Find the area of a room whose dimensions are $4\frac{1}{3}$ by $6\frac{2}{3}$ yards.
34. Find the LCM of 16 and 20.
35. Find the LCM of 19 and 76.
36. Find the LCD of $\frac{7}{9}$ and $\frac{5}{12}$ and write $\frac{7}{9}$ and $\frac{5}{12}$ as equivalent fractions with the LCD as denominator.
37. Find the LCD of $\frac{7}{10}$, $\frac{5}{6}$, and $\frac{3}{5}$ and write $\frac{7}{10}$, $\frac{5}{6}$, and $\frac{3}{5}$ as equivalent fractions with the LCD as denominator.

This page intentionally left blank

Section

Chapter

- 3.1** Addition and Subtraction of Decimals
- 3.2** Multiplication and Division of Decimals
- 3.3** Fractions and Decimals
- 3.4** Decimals, Fractions, and Order of Operations
- 3.5** Equations and Problem Solving

3 three

▶ Decimals

The Human Side of Mathematics

The introduction of a decimal system of money has made the use of **decimals** much more common. Even our stock market now uses decimals rather than fractions to quote the value of stocks.

Modern methods of writing decimals were invented less than 500 years ago, but their use can be traced back thousands of years. As far back as 1579 the Italian/French mathematician Francois Vieta called for the use of the decimal system in his book *Canon Mathematicus*.

The daily use of the decimal system was popularized by a book published in 1586 by Simon Stevin, a Dutch mathematician born in 1548. The book was aptly titled *The Thiende* (The Tenth). His aim: “To perform with an ease unheard of, all computations necessary between men by integers without fractions.” This is one of our aims as well.

The notation used in our decimal system has evolved through time. The decimal point separating the whole part from the decimal part seems to have been the invention of Bartholomaeus Pitiscus, who used it in his trigonometrical tables in 1612. Our familiar decimals were used by John Napier, a Scottish mathematician, who developed the use of logarithms for carrying out complex calculations. The modern decimal point became standard in England in 1619, but many countries in Europe still use the decimal **comma** rather than the decimal **point**. (They write 3,1416 rather than 3.1416.) Whether you use commas or periods for the decimal, the objective is the same: to make clear where the ones column is!

Account Types	Annual Percentage Yield (APY)	Annual Interest Rate (AIR)
3 Month C/D (US\$1,000 Minimum Opening Deposit)	1.95	.
6 Month C/D (US\$1,000 Minimum Opening Deposit)	2.15	.
12 Month C/D (US\$1,000 Minimum Opening Deposit)	2.35	.
12, 18 Month Club Savings (US\$1,000 Minimum Contract Amount)	3.05	3.00
24, 30 Month Club Savings (US\$1,000 Minimum Contract Amount)	3.82	3.75
36 Month Club Savings (US\$1,000 Minimum Contract Amount)	4.60	4.50
N.O.W. (US\$1,500 Minimum Opening Deposit)	1.01	1.00
Money Market (US\$1,000 Minimum Opening Deposit)	1.26	1.25
Statement Savings (US\$ 500 Minimum Opening Deposit)	1.01	1.00
Personal Checking Account (Basic Checking Account)	0.00	0.00

Unit: %

N.O.W., Money Market, Statement Savings and Passbook Savings Account rates are subject to change weekly. N.O.W. Account balance below US\$1,500. Money Market Account balance below US\$1,000 and Statement Savings Account balance below US\$100 will incur fees. Annual Percentage Yield assumes principal and interest are remaining on deposit for one year at the same rate of interest, compounded daily. Substantial penalties will be imposed for early withdrawal of C/Ds, Club Savings. Please contact Customer Service Desk for further information about applicable fees, terms and others. Please Inquire About Our Low Cost Checking Account Thank You.

CHB CHO HUNG BANK OF NEW YORK
Member FDIC

3.1

Addition and Subtraction of Decimals

▶ Objectives

You should be able to:

- A > Write the word name for a decimal.
- B > Write a decimal in expanded form.
- C > Add two or more decimals.
- D > Subtract one decimal from another.

▶ To Succeed, Review How To . . .

1. Write the word name for a number. (p. 9)
2. Write a number in expanded form. (p. 4)
3. Work with the addition and subtraction facts. (pp. 24, 38)

▶ Getting Started

Can you buy a dozen students with an ID for \$7.29? No, but if you are a student with an ID you can buy a dozen doughnuts for \$7.29! The \$7.29 contains the **decimal** part .29. In the **decimal** (the Latin word for *ten*) **system** we use the digits to count from 1 to 9; then we use the numbers 1 and 0 to express ten, the **base** of the system. The \$7.29 in the ad has a **decimal point** separating the **whole-number part** (7) from the **decimal part** (.29). You can think of \$7.29 as

\$7 and 29¢

or as

\$7 and $\$ \frac{29}{100}$

since 1 cent is one hundredths of a dollar ($\$ \frac{1}{100}$).



A > Writing Word Names for Decimals

In Chapter 2 we represented a part of a whole by using **fraction notation**. We can also represent a part of a whole using **decimal notation**. A number written in **decimal notation** is simply called a **decimal**. The decimal number system was introduced in A.D. 1619 by the Scottish mathematician John Napier. A **decimal** consists of three parts:

1. The **whole-number part**.
2. A **period**, **.**, called the **decimal point**.
3. The **decimal part**.

Thus, in the decimal **247.83** the whole-number part is **247** and the decimal part is **.83**. When we use the decimal system we can write fractions without explicitly writing the numerator and denominator. For example, in the decimal system the decimal fraction $\frac{7}{10}$ is written as the **decimal** **0.7** and read as *seven tenths* or *zero point 7*. Note that the decimal 0.7 does not have a whole-number part, so we placed a zero to the left of the decimal point. In general, the **number of decimal places** in a number is the **number of digits to the right of the decimal point**. Thus, 0.19 has *two* decimal places and 57.568 has *three* decimal places. How many decimal places in a whole number such as 100? Technically, **0** but when dealing with money we usually write \$100 as \$100.**00**. (\$100 is the same as \$100 and *no* cents!)

The place value chart used in Chapter 1 can be extended to include decimals so the place values are 100, 10, 1, $\frac{1}{10}$, $\frac{1}{100}$, and so on to help us write decimals in words as shown.

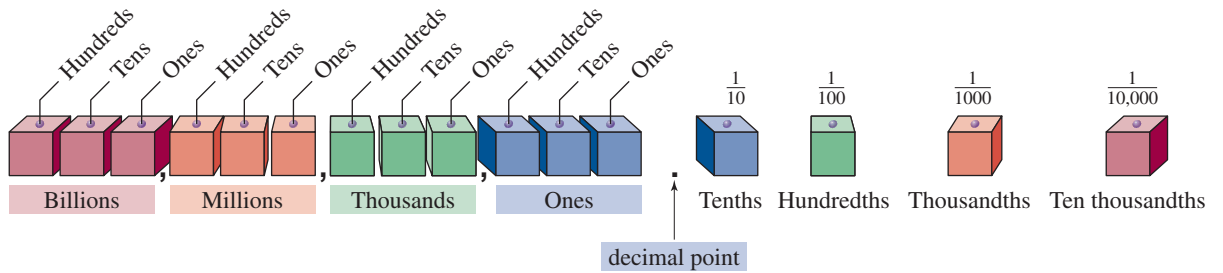

Notice that the names for the place values to the right of the decimal point end with **th**. A decimal fraction such as $\frac{9}{10}$ is read as *nine tenths* and $\frac{41}{100}$ is read as *forty-one hundredths*. How do we write 7.29 in words? Since 7 and $\frac{29}{100}$ can be written as $7\frac{29}{100}$, we can write 7.29 as seven and twenty-nine hundredths. Use the diagram to help in writing the word name for 284.356.

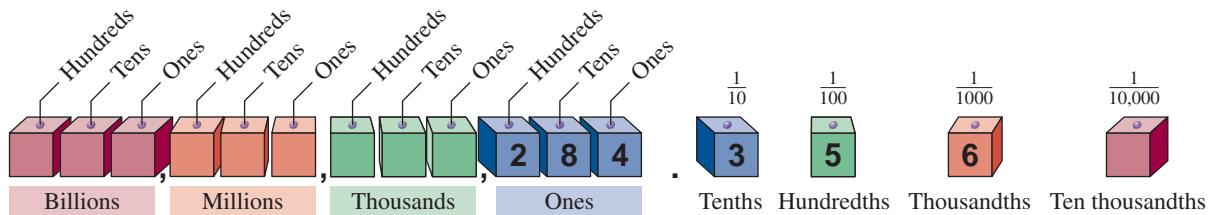

TO WRITE THE WORD NAME FOR A DECIMAL

1. Write the word name for the whole-number part (the number to the left of the decimal point).
2. Write the word *and* for the decimal point.
3. Write the word name for the number to the right of the decimal point, followed by the place value of the *last* digit.

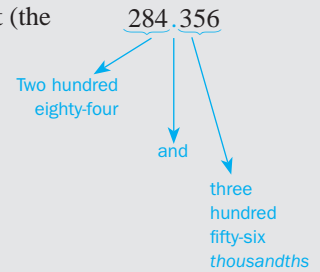

EXAMPLE 1 Writing a number in words
Give the word name for 187.93.

SOLUTION 1 One hundred eighty-seven *and* ninety-three hundredths

PROBLEM 1
Write the word name for 147.17.

B > Writing Decimals in Expanded Form

Let us go back to \$7.29. You can think of \$7.29 as

$$\$7 + 2 \text{ dimes} + 9 \text{ cents}$$

or

$$\$7 + \frac{2}{10} + \frac{9}{100}$$

since a dime is one-tenth of a dollar ($\frac{1}{10}$) and a cent is one-hundredth of a dollar ($\frac{1}{100}$). When we write 7.29 as $7 + \frac{2}{10} + \frac{9}{100}$, we say that 7.29 is written in **expanded form**. Similarly, the decimal 284.356 can be written in expanded form like this:

$$200 + 80 + 4 + \frac{3}{10} + \frac{5}{100} + \frac{6}{1000}$$

Answers to PROBLEMS

1. One hundred forty-seven and seventeen hundredths

EXAMPLE 2 Using expanded form

Write 35.216 in expanded form.

SOLUTION 2

$$30 + 5 + \frac{2}{10} + \frac{1}{100} + \frac{6}{1000}$$

PROBLEM 2

Write 47.321 in expanded form.

C > Adding Decimals

Adding decimals is similar to adding whole numbers: line up the place values and add the numbers in each place value (hundredths, tenths, ones, tens, and so on), carrying if necessary. For example,

$$0.2 + 0.7 = 0.9$$

This is because $0.2 = \frac{2}{10}$ and $0.7 = \frac{7}{10}$. Thus,

$$0.2 + 0.7 = \frac{2}{10} + \frac{7}{10} = \frac{2+7}{10} = \frac{9}{10} = 0.9$$

If the addition is done using a vertical column as we did with whole numbers, we place the tenths digit in the tenths column and the ones (units) digits in the units column. We then proceed as shown in the diagram.

$$\begin{array}{r|l} \text{decimal point column} & \text{tenths column} \\ \hline 0.2 & \\ + 0.7 & \\ \hline 0.9 & \end{array}$$

Note that 0.2 and 0.7 have *no* whole number parts (pure decimals) and are written with a 0 to the left of the decimal point.

Similarly, $3.2 + 4.6$ is added like this:

Short Form

$$\begin{array}{r} 3.2 \\ + 4.6 \\ \hline 7.8 \end{array}$$

Long Form

$$\begin{array}{l} 3 + \frac{2}{10} \\ 4 + \frac{6}{10} \\ \hline 7 + \frac{8}{10} = 7\frac{8}{10} = 7.8 \end{array}$$

Of course, we use the short form to save time, making sure we line up (align) the decimal points by writing them in the *same* column and then making sure that digits of the same place value are in the same column. Here is the way to add:

$$\begin{array}{r} 4.13 \\ + 5.24 \\ \hline 9.37 \end{array}$$

Step 1. Align the decimal points; that is, write them in the same column.

Step 2. Add hundredths.

Step 3. Add tenths.

Step 4. Add units.

The result is 9.37.

Answers to PROBLEMS

2. $40 + 7 + \frac{3}{10} + \frac{2}{100} + \frac{1}{1000}$

EXAMPLE 3 Adding decimalsAdd $5 + 12.15$.**SOLUTION 3**

$$\begin{array}{r} 5.00 \\ +12.15 \\ \hline 17.15 \end{array}$$

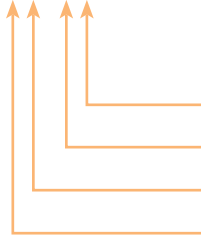
**Step 1.** Note that $5 = 5.00$.**Step 2.** Align the decimal points.**Step 3.** Attach placeholder zeros to the 5, so that both addends have the same number of decimal digits.**Step 4.** Add hundredths.**Step 5.** Add tenths.**Step 6.** Add units.**Step 7.** Add tens.**PROBLEM 3**Add $4 + 12.4$.

Note that 5 was written as 5.00. This is possible because

$$5.00 = 5 + \frac{0}{10} + \frac{0}{100}$$

Thus,

$$5 = 5.00$$

What happens if we have to carry when adding decimals, and what does it mean?

Short Form

$$\begin{array}{r} 4.8 \\ +3.7 \\ \hline 8.5 \end{array}$$

$.8 + .7 = 1.5$
 write .5, carry 1
 $1 + 4 + 3 = 8$

Expanded Form

$$\begin{aligned} &4 + \frac{8}{10} \\ &+ 3 + \frac{7}{10} \\ \hline &7 + \frac{8+7}{10} = 7 + \frac{15}{10} \\ &= 7 + \frac{10}{10} + \frac{5}{10} \\ &= 7 + 1 + \frac{5}{10} \\ &= 8 + \frac{5}{10} \\ &= 8.5 \end{aligned}$$

Note that in the expanded form, $0.8 + 0.7 = \frac{8}{10} + \frac{7}{10} = \frac{15}{10}$. We carry 1 (regroup) because we write $\frac{15}{10} = \frac{10}{10} + \frac{5}{10} = 1 + \frac{5}{10}$, leaving the $\frac{5}{10}$ in the first column and carrying the 1 to the ones' place.

EXAMPLE 4 Adding decimalsAdd $32.663 + 8.58$.**PROBLEM 4**Add $49.28 + 7.921$.*(continued)***Answers to PROBLEMS**

3. 16.4 4. 57.201

SOLUTION 4**Short Form**

$$\begin{array}{r} 11 \\ 32.663 \\ + 8.580 \\ \hline 41.243 \end{array}$$

Expanded Form

$$\begin{aligned} & 32 + \frac{6}{10} + \frac{6}{100} + \frac{3}{1000} \\ & + 8 + \frac{5}{10} + \frac{8}{100} + \frac{0}{1000} \\ \hline & 40 + \frac{11}{10} + \frac{14}{100} + \frac{3}{1000} \\ & = 40 + \frac{10}{10} + \frac{1}{10} + \frac{10}{100} + \frac{4}{100} + \frac{3}{1000} \\ & = 40 + \frac{1 + \frac{1}{10}}{1} + \frac{1}{10} + \frac{4}{100} + \frac{3}{1000} \\ & = 41 + \frac{2}{10} + \frac{4}{100} + \frac{3}{1000} \\ & = 41.243 \end{aligned}$$

Keep using the short form to save time!

We can also add more than two numbers involving decimals as long as we continue to align the decimal points. For example, suppose you owe \$3748.74 on a mortgage, \$517.46 on a car, \$229 on credit cards, and \$550.51 on personal loans. How much do you owe? To find the answer we must *add* all these quantities. We do this in Example 5.

EXAMPLE 5 Adding decimals

Add \$3748.74, \$517.46, \$229, and \$550.51 to find how much you owe.

SOLUTION 5 First we note that \$229 = \$229.00. (If you have \$229, you have \$229 and no cents; thus, \$229 = \$229.00.) We then proceed by steps:

$$\begin{array}{r} 2121 \\ 3748.74 \\ 517.46 \\ 229.00 \\ 550.51 \\ \hline 5045.71 \end{array}$$

Step 1. Align the decimal points.

Step 2. Add hundredths.

Step 3. Add tenths.

Step 4. Add units.

Step 5. Add tens.

Step 6. Add hundreds.

Step 7. Add thousands.

Thus, you owe \$5045.71.

PROBLEM 5

A student owes \$11,022.77 on his mortgage, \$1521.54 on his car, \$674 on credit cards, and \$1618.73 on personal loans. How much does he owe?

D > Subtracting Decimals

Subtraction of decimals is like subtraction of whole numbers as long as you remember to align the decimal points and insert any placeholder zeros so that both numbers have

Answers to PROBLEMS

5. \$14,837.04

the *same* number of decimal digits. For example, if you earned \$231.47 and you made a \$52 payment, you have $\$231.47 - \52 . To find the answer we write.

$$\begin{array}{r} 231.47 \\ - 52.00 \\ \hline 179.47 \end{array}$$

Align the decimal points.
Attach two zeros (\$52 is the same as \$52 and no cents or \$52.00).
The decimal point is in the same column.

Thus, you have \$179.47 left. You can check this answer by adding \$52 and \$179.47, obtaining \$231.47.

EXAMPLE 6 Subtracting decimals

Subtract $383.43 - 17.5$.

SOLUTION 6

$$\begin{array}{r} 83.43 \\ - 17.50 \\ \hline 65.93 \end{array}$$

Step 1. Align the decimal points.
Step 2. Attach one zero.
Step 3. Subtract.
The decimal point is in the same column.

PROBLEM 6

Subtract $742.32 - 13.6$.

EXAMPLE 7 Subtracting decimals

Subtract $347.8 - 182.231$.

SOLUTION 7

$$\begin{array}{r} 47.800 \\ - 182.231 \\ \hline 165.569 \end{array}$$

Step 1. Align the decimal points.
Step 2. Attach two zeros.
Step 3. Subtract.
The decimal point is in the same column.

PROBLEM 7

Subtract $429.6 - 233.381$.

Global warming can do many things to the Earth: burn the rain forest, kill all plants, and melt the polar ice causing flooding in New York, Florida, and California. Is there a trend? See for yourself in Example 8, but keep in mind that the data are limited. For a more complete picture go to http://www.earth-policy.org/datacenter/xls/indicator8_2010_1.xls.

GREEN MATH

EXAMPLE 8 Global warming warnings

The table shows the average global temperature in degrees Fahrenheit ($^{\circ}\text{F}$) for several years.

1905	56.75	2005	58.56
1906	56.93	2006	58.38
1907	56.48	2007	58.51

- Is there a definite warming trend in the 1900s? In the 2000s?
- Find the difference in temperature between 2005 (58.56°F) and 1905 (56.75°F).
- Find the difference in temperature between 2007 (58.51°F) and 1907 (56.48°F).

PROBLEM 8

- Is the change in temperatures accelerating? (*Hint:* Look at the answers for parts **b** and **c**, 1.81°F and 2.03°F , respectively.)
- Find the difference in temperature between 2006 and 1906.

(continued)

Answers to PROBLEMS

6. 728.72 7. 196.219 8. a. Yes, the change went from 1.81°F to 2.03°F b. 1.45°F

SOLUTION 8

- a. There seems to be no pattern in the 1900s (increase from 56.75 to 56.93 then a decrease to 56.48). No definite pattern in the 2000s temperatures (down, then up).
- b. We have to find the difference $58.56 - 56.75$. We do it by steps.

$$\begin{array}{r} 58.56 \\ -56.75 \\ \hline 1.81 \end{array}$$

Step 1. Align the decimal points.**Step 2.** Subtract.

Thus, the change in temperature from 1905 to 2005 was 1.81°F . You can check this by adding 56.75 and 1.81 obtaining 58.56.

- c. We need the difference $58.51 - 56.48$. Here are the steps.

$$\begin{array}{r} 58.51 \\ -56.48 \\ \hline 2.03 \end{array}$$

Step 1. Align the decimal points.**Step 2.** Subtract.

Thus, the change in temperature from 1907 to 2007 was 2.03°F .

Check: $56.48 + 2.03 = 58.51$, so our answer is correct.

Some scientists argue that the global average of temperature **readings** are increasing, not the temperatures themselves, because heat sources are being located near the official temperature recording stations.



As you can see, decimals are everywhere, and you have to know how to use them! Many interstate highways have signs (like the one shown) at the exits. For example, if you want to know how far you are from Shoney's Inn, you simply read the answer: 0.5. Of course, it is assumed that you understand that these distances are in miles. Thus, when you get off the interstate and take a left, you are 0.5 or $\frac{1}{2}$ mile from Shoney's Inn.

EXAMPLE 9 Subtracting decimals

Using the photo above, find the following:

- How far is the Happy Traveler RV Park?
- How far is it from the Holiday Inn to the Wingate Inn?
- If you decide to walk from the Happy Traveler RV Park to the Holiday Inn, how far do you have to walk?

SOLUTION 9

- The Happy Traveler RV Park is 0.8 miles to the right.
- The Holiday Inn is 4.6 miles to the left and the Wingate Inn is 3.7 miles to the left, so the distance from the Holiday Inn to the Wingate Inn is $4.6 - 3.7$ miles.



Here is the subtraction:

$$\begin{array}{r} 3.16 \\ 4.6 \\ -3.7 \\ \hline 0.9 \end{array}$$

Align the decimal points.

Subtract.

Thus, the Holiday Inn is 0.9 mile from the Wingate Inn.

- Note that to go to the Happy Traveler RV Park you have to go right, but the Holiday Inn is to the *left*. Thus, the distance from the Happy Traveler RV Park to the Holiday Inn is $0.8 + 4.6$ miles.

PROBLEM 9

- How far is La Quinta Inn?
- How far is it from the Holiday Inn to Shoney's Inn?
- How far is it from the Happy Traveler RV Park to the Wingate Inn?

Answers to PROBLEMS

9. a. 3.5 mi to the left b. 4.1 mi c. 4.5 mi

Here is the addition:

$$\begin{array}{r}
 \text{H}(4.6) \qquad \qquad \text{RV}(0.8) \qquad \qquad \begin{array}{r} 1 \\ 0.8 \\ + 4.6 \\ \hline 5.4 \end{array} \\
 \begin{array}{c} \longleftarrow \qquad \qquad \longrightarrow \\ \longleftarrow \qquad \qquad \longrightarrow \end{array}
 \end{array}$$

Align the decimal points.

Add.

Thus, you have to walk 5.4 miles from the Happy Traveler RV Park to get to the Holiday Inn.



Calculator Corner

If you use a calculator to add or subtract decimals, you do not have to worry about aligning the decimal point or entering the zero to the left of the decimal because the calculator will align the numbers for you.

Thus, to add 0.2 and 0.3, we press \cdot 2 + \cdot 3 ENTER. Moreover, to add $5 + 12.15$ (Example 3), you simply press 5 + 1 2 \cdot 1 5 ENTER, without having to write the 5 as 5.00.

The same idea works in subtraction. Thus, if you earned \$231.47 and made a \$52 payment, you have $\$231.47 - \52 left. To find how much you have left, simply press 2 3 1 \cdot 4 7 - 5 2 ENTER, obtaining \$179.47.

> Exercises 3.1



> Practice Problems > Self-Tests
> Media-rich eBooks > e-Professors > Videos

< **A** > **Writing Word Names for Decimals** In Problems 1–10, write the word name for the number.

- | | |
|-----------|------------|
| 1. 3.8 | 2. 9.6 |
| 3. 13.12 | 4. 46.78 |
| 5. 132.34 | 6. 394.05 |
| 7. 5.183 | 8. 9.238 |
| 9. 0.2172 | 10. 0.3495 |

< **B** > **Writing Decimals in Expanded Form** In Problems 11–20, write in expanded form.

- | | | |
|-------------|-------------|--------------|
| 11. 3.21 | 12. 4.7 | 13. 41.38 |
| 14. 37.10 | 15. 89.123 | 16. 13.278 |
| 17. 238.392 | 18. 312.409 | 19. 301.5879 |
| 20. 791.354 | | |

< **C** > < **D** > **Adding Decimals and Subtracting Decimals**

In Problems 21–60, add or subtract as required.

- | | | | |
|-----------------|-----------------|-------------------|-------------------|
| 21. $0.4 + 0.1$ | 22. $0.3 + 0.2$ | 23. $0.6 + 0.9$ | 24. $0.4 + 0.8$ |
| 25. $0.3 - 0.1$ | 26. $0.7 - 0.4$ | 27. $8.3 - 5.2$ | 28. $7.5 - 4.4$ |
| 29. $5 - 3.2$ | 30. $8 - 7.3$ | 31. $9 - 4.1$ | 32. $6 - 3.5$ |
| 33. $3.8 - 1.9$ | 34. $2.6 - 1.7$ | 35. $1.1 - 0.8$ | 36. $3.4 - 0.5$ |
| 37. $12.23 + 9$ | 38. $13.24 + 8$ | 39. $4.6 + 18.73$ | 40. $7.8 + 16.31$ |

41. $17.35 - 8.4$ 42. $13 - 7.5$ 43. $\$648.01 + \341.06
 44. $\$237.49 + \458.72 45. $72.03 + 847.124$ 46. $13.12 + 108.138$
 47. $104 + 78.103$ 48. $184 + 69.572$ 49. $0.35 + 3.6 + 0.127$
 50. $5.2 + 0.358 + 21.005$ 51. $27.2 - 0.35$ 52. $4.6 - 0.09$
 53. $19 - 16.62$ 54. $99 - 0.161$ 55. $9.43 - 6.406$
 56. $9.08 - 3.465$ 57. $8.2 - 1.356$ 58. $6.3 - 4.901$
 59. $6.09 + 3.0046$ 60. $2.01 + 1.3045$

Applications

61. *Trip length* The mileage indicator on a car read 18,327.2 at the beginning of a trip. At the end of the trip, it read 18,719.7. How long was the trip?
62. *Nicotine content* The highest nicotine content for a nonfilter cigarette is 1.7 milligrams. Another brand contains 0.8 milligram. What is the difference in the nicotine amounts?
63. *Total spending* A woman wrote checks for \$18.47, \$23.48, and \$12.63. How much did she spend?
64. *Swimming records* In 1972 Mark Spitz established an Olympic swimming record in the 100-meter butterfly. He finished in 54.27 seconds. In 1988 Anthony Nesty finished in 53 seconds. How much faster was Nesty?
65. *Springboard records* In 1984 Greg Louganis won the springboard diving in the Olympics by scoring 754.41 points. He won again in 1988 by scoring 730.80. How many fewer points did he score in 1988?
66. *Change for a twenty* A man bought merchandise costing \$6.84. He paid with a \$20 bill. How much change did he receive?

Anatomy—body composition The following information will be used in Problems 67–70.

By weight the average adult is composed of

43%	muscle	2.7%	liver	0.5%	kidneys
26%	skin	2.2%	brain	0.5%	heart
17.5%	bone	2.2%	intestines	0.2%	spleen
7%	blood	1.5%	lungs	0.1%	pancreas

However, an old-time song, named *16 Tons*, makes the following claim about the body of miners:

Some people say a man is made of mud,
 Bone, skin, muscle, and blood.

Muscle and blood, skin and bone,

I owe my soul to the company store.

67. What percent of an average adult is composed of skin, muscle, blood, and bone?
68. Since the weight of all body parts must add up to 100%, if a person is made up of mud, skin, muscle, blood, and bone, what percent is mud?
69. There is another difficulty with these data. Add up all the percents and see what it is!
70. How much over 100% is the amount obtained in Problem 69?

Note that you don't have to know about percent yet (that will come in Chapter 4); you only have to know addition!

Credit Do you know what your FICO (Fair Isaac Credit Organization) score is? "When you apply for credit, lenders want to know what risk they'd take by loaning money to you. FICO scores are the credit scores most lenders use to determine your credit risk. You have three FICO scores, one for each of the three credit bureaus: Experian, TransUnion, and Equifax." Source: <http://myfico.com/>.

The higher your FICO® scores, the less you pay to buy on credit—no matter whether you're getting a home loan, a cell phone, a car loan, or signing up for credit cards. For example, on a \$216,000 30-year, fixed-rate mortgage:

If Your FICO® Score Is	Your Interest Rate Is	... And Your Monthly Payment Is	And Your Total Payment Is
1. 760–850	6.2%	\$1322.93	\$476,254.80
2. 700–759	6.42%	\$1353.92	\$487,411.20
3. 680–699	6.6%	\$1379.50	\$496,620.00
4. 660–679	6.81%	\$1409.60	\$507,456.00
5. 640–659	7.24%	\$1472.04	\$529,934.40
6. 620–639	7.79%	\$1553.43	\$559,234.80

In Problems 71 through 76, find the difference in *monthly payment* and the difference in *total payment* between persons in the specified categories:

71. Category 1 (760–850) and category 6 (620–639)

72. Category 1 (760–850) and category 5 (640–659)

73. Category 1 (760–850) and category 4 (660–679)

74. Category 1 (760–850) and category 3 (680–699)

75. Category 1 (760–850) and category 2 (700–759)

76. Category 2 (700–759) and category 3 (680–699)

Applications: Green Math

Some scientists claim a relationship between global warming and CO₂ (carbon dioxide concentrations in the atmosphere). The world's most current data for atmospheric CO₂ (in parts per million, ppm) is from measurements at the Mauna Loa Observatory in Hawaii, started by David Keeling in 1958.

Source: <http://co2now.org/>.

YEAR	CO ₂ (ppm)	YEAR	CO ₂ (ppm)
1967	322.16	2007	384.42
1968	323.04	2008	385.96
1969	324.62	2009	388.79

In Exercises 77–80, refer to the table to find:

77. The difference in CO₂ concentration between 2007 and 1967.

78. The difference in CO₂ concentration between 2008 and 1968.

79. The difference in CO₂ concentration between 2009 and 1969.

80. Was the CO₂ concentration increasing in the 1960s? 2000s?

Using Your Knowledge

Balancing Your Checkbook Here is a bank statement sent to a depositor. The balance on the statement is \$568.40. Unfortunately, this balance may be different from the one in the depositor's checkbook.

FIRST BANK OF MAPLE POINT MAPLE POINT, IL 68122		STATEMENT OF ACCOUNT		PAGE 1						
CHARLES SMITH 206 FAIR LN. FORT KEY, IL 68121		ACCOUNT NUMBER 1000824431		STATEMENT PERIOD FROM 07-06-2006 TO 08-06-2006						
Account Number Type 1000824431 Free Checking		Balance		568.40						
Account Summary for Free Checking - 1000824431										
Starting Balance	+	Deposits	+	Interest Paid	-	Withdrawals	-	Service Charges	=	Ending Balance
228.90		450.00		0.00		110.50		0.00		568.40
Transactions for Free Checking - 1000824431										
Date	Description	Checks/ Debits	Deposits/ Credits	Balance						
07-06	Starting Balance			228.90						
07-27	Check	-50.00		178.90						
07-28	Check	-30.00		148.90						
07-29	Check	-10.50		138.40						
07-30	Deposit		100.00	238.40						
08-02	Check	-20.00		218.40						
08-03	Deposit		350.00	568.40						

On the reverse side of the statement is a reconciliation form. It shows three outstanding checks for \$27.50, \$50.00, and \$10.00. (form on the right)

THIS FORM IS PROVIDED TO HELP YOU BALANCE YOUR BANK STATEMENT

CHECKS OUTSTANDING NOT CHARGED TO ACCOUNT			MONTH	20
NO.	DOLLARS	CENTS	BANK BALANCE SHOWN ON THIS STATEMENT	
5	27	50	\$ 568.40	
9	50	00	ADD+ DEPOSITS NOT CREDITED IN THIS STATEMENT (IF ANY)	
14	10	00	90.00	
			60.30	
			TOTAL	
			\$	
TOTAL			SUBTRACT- CHECKS OUTSTANDING	
			BALANCE	
			\$	
SHOULD AGREE WITH YOUR CHECK BOOK BALANCE AFTER DEDUCTING SERVICE CHARGE (IF ANY) SHOWN ON THIS STATEMENT				

HINTS FOR FINDING DIFFERENCES

RE-CHECK THE ADDITION, SUBTRACTION AND CORRECTIONS ON THIS RECONCILEMENT FORM AND IN YOUR CHECKBOOK.

VERIFY THE CARRY OVER OF THE BALANCE FROM PAGE TO PAGE OF YOUR CHECKBOOK.

MAKE SURE YOU HAVE SUBTRACTED THE SERVICE CHARGE, IF ANY, FROM YOUR CHECKBOOK BALANCE.

COMPARE THE AMOUNT ENCODED IN THE LOWER RIGHT HAND CORNER OF EACH CHECK WITH THE AMOUNT RECORDED IN YOUR CHECKBOOK.

81. What is the sum of these checks?

The reconciliation form shows two deposits of \$90.00 and \$60.30 not credited.

82. What is the sum of \$90.00 and \$60.30?

The form directs the depositor to add the bank balance and the deposits not credited to get the total. (See the form above right.)

83. What is the total?

Then, to find the balance we subtract the outstanding checks from the total.

84. Find the balance.

Distance Answer questions 85–88.



85. How far is it to the Wingate Inn?
 86. How far is it from Shoney's to La Quinta?
 87. How far is it from La Quinta to the Holiday Inn?
 88. How far is it from the Happy Traveler RV Park to La Quinta?

>>> Write On

93. Pedro read the number 3805 as “three thousand eight hundred and five.” What is wrong with the way Pedro read the number?
 94. Milé read the number 18.105 as “Eighteen and one hundred and five thousandths.” What is wrong with the way Milé read the number?
 95. What is the difference between: Subtract “3 from 4.8” and “6.6 minus 4.8”? What answer do you get in each case?

>>> Concept Checker

Fill in the blank(s) with the correct word(s), phrase, or mathematical statement.

96. When writing the word name for a decimal, we use the **word** _____ for the decimal point.
 97. A decimal consists of three parts, the _____ **number** part, the _____ **point**, and the _____ **part**.
 98. The number of decimal places in a number is the number of **digits** to the _____ of the decimal point.
 99. **Fractions** such as $\frac{1}{10}$, $\frac{1}{100}$, and $\frac{1}{1000}$ are called _____ fractions.

decimal **left**
right **and**
whole **or**

>>> Mastery Test

100. Add: $7 + 13.18$
 101. Add: $38.773 + 3.69$
 102. Your bills for this month are: \$47.10 for the phone, \$59.49 for electricity, \$258.20 for the car payment, \$308 for the rent, and \$105.27 for miscellaneous expenses. What is the total for all your bills?
 103. Write 41.208 in expanded form.

Distance Many interstate highways have signs like the one shown indicating how far food is!

89. How far is McDonald's?
 90. How far is it from McDonald's to Perkins?
 91. How far apart are Burger King and McDonald's?
 92. If you decide to walk from the 76 station to Perkins, how far do you have to walk?



104. Write the word name for 283.98.

105. Subtract: $473.43 - 18.6$

106. Subtract: $458.9 - 293.342$

107. How far is it from  to ?

108. How far is it from  to ?



>>> Skill Checker

Multiply.

109. 23×10

111. 240×1000

113. Round 3487 to the nearest hundred.

110. 235×100

112. Round 237 to the nearest ten.

114. Round 5480 to the nearest thousand.

3.2

Multiplication and Division of Decimals

▶ Objectives

You should be able to:

- A** > Find the product of (multiply) two decimals.
- B** > Find the product of decimals involving a power of 10.
- C** > Find the quotient of (divide) two decimals.
- D** > Round a number to a specified number of decimal digits or places.
- E** > Find the quotient of decimals involving a power of 10.
- F** > Solve applications involving the concepts studied.

▶ To Succeed, Review How To . . .

1. Write a decimal in expanded form. (pp. 211–212)
2. Multiply or divide a whole number by a power of 10. (pp. 55–56)

▶ Getting Started

The man in the picture sold three lollipops that cost 30¢ (\$0.30) each. How much is the bill? To find the answer we must find

$$3 \times 0.30$$

which is 0.90, but do you know why? Since $0.30 = \frac{30}{100}$ and $3 = \frac{3}{1}$, we multiply

$$\frac{3}{1} \times \frac{30}{100} = \frac{90}{100} = 0.90$$

That is, the bill comes to 90¢. Note that we could simply have multiplied $3 \times 30 = 90$

and then placed the decimal point correctly in the result. To learn *where* to place the decimal point, look at these multiplications. The number in color indicates how many *decimal digits* (digits to the *right* of the decimal point) the number has.



$$0.\underset{\color{blue}{1}}{\underset{\color{blue}{1}}{3}} \times 7 = \frac{3}{10} \times 7 = \frac{21}{10} = 2\frac{1}{10} = 2 + \frac{1}{10} = 2.\underset{\color{blue}{1}}{1}$$

$$0.\underset{\color{blue}{1}}{3} \times 0.\underset{\color{blue}{1}}{7} = \frac{3}{10} \times \frac{7}{10} = \frac{21}{100} = 0.\underset{\color{blue}{2}}{21}$$

$$0.\underset{\color{blue}{1}}{3} \times 0.\underset{\color{blue}{2}}{07} = \frac{3}{10} \times \frac{7}{100} = \frac{21}{1000} = 0.\underset{\color{blue}{3}}{021}$$

$$0.\underset{\color{blue}{1}}{3} \times 0.\underset{\color{blue}{3}}{007} = \frac{3}{10} \times \frac{7}{1000} = \frac{21}{10,000} = 0.\underset{\color{blue}{4}}{0021}$$

A > Multiplying Decimals

When you multiply decimals, the number of decimal digits in the product is the *sum* of the number of decimal digits in the factors. For example, 0.3 has *one* decimal digit and 0.0007 has *four*; the product,

$$0.\underset{\color{blue}{1} \text{ decimal digit}}{3} \times 0.\underset{\color{blue}{4} \text{ decimals digits}}{0007} = \frac{3}{10} \times \frac{7}{10,000} = \frac{21}{100,000} = 0.\underset{\color{blue}{1 + 4 = 5 \text{ decimal digits}}}{00021}$$

has $1 + 4 = 5$ decimal digits. Here is the rule used to multiply decimals:

TO MULTIPLY DECIMALS

1. Multiply the two decimal numbers *as if they were whole numbers*.
2. The *number of decimal digits* in the product is the *sum* of the number of decimal digits in the factors.

Now let us find the price of 3.5 and 5 pounds of roast selling at \$2.29 per pound. Following the rule just given, we have



Price for 3.5 Pounds

$$\begin{array}{r} 2.29 \\ \times 3.5 \\ \hline 1145 \\ 687 \\ \hline 8.015 \end{array}$$

Count 2 + 1 = 3 decimal digits from the right in the answer.

The price is about \$8.02.

Price for 5 Pounds

$$\begin{array}{r} 2.29 \\ \times 5 \\ \hline 11.45 \end{array}$$

Count 2 + 0 = 2 decimal digits from the right in the answer.

The price is \$11.45.

EXAMPLE 1 Multiplying decimals

Multiply: a. $\begin{array}{r} 2.31 \\ \times 4.2 \\ \hline \end{array}$ b. $\begin{array}{r} 13.813 \\ \times 7.1 \\ \hline \end{array}$

SOLUTION 1

a. $\begin{array}{r} 2.31 \\ \times 4.2 \\ \hline 462 \\ 924 \\ \hline 9.702 \end{array}$ Count 2 + 1 = 3 decimal digits.

b. $\begin{array}{r} 13.813 \\ \times 7.1 \\ \hline 13813 \\ 96691 \\ \hline 98.0723 \end{array}$ Count 3 + 1 = 4 decimal digits.

PROBLEM 1

Multiply: a. $\begin{array}{r} 3.12 \\ \times 5.3 \\ \hline \end{array}$ b. $\begin{array}{r} 12.172 \\ \times 5.1 \\ \hline \end{array}$

Answers to PROBLEMS

1. a. 16.536 b. 62.0772

Sometimes we need to *prefix* zeros to (write zeros before) the product to obtain the required number of decimal digits. For example:

$$\begin{array}{r} 0.005 \quad 3 \text{ decimal digits} \\ \times \quad 3 \quad 0 \text{ decimal digits} \\ \hline .015 \quad 3 + 0 = 3 \text{ decimal digits.} \end{array}$$

We need 3 decimal digits. Zero is inserted to obtain 3 decimal digits.

(Note that $0.005 \times 3 = \frac{5}{1000} \times 3 = \frac{15}{1000}$.)

The answer is written as 0.015.

$$\begin{array}{r} 0.016 \quad 3 \text{ decimal digits} \\ \times 0.23 \quad 2 \text{ decimal digits} \\ \hline 48 \\ 32 \\ \hline .00368 \quad 3 + 2 = 5 \text{ decimal digits.} \end{array}$$

3 + 2 = 5 decimal digits.

2 zeros inserted here to obtain 5 decimal digits.

The answer is written as 0.00368.

EXAMPLE 2 Multiplying decimals

Multiply:

a.
$$\begin{array}{r} 5.102 \\ \times 21.03 \\ \hline \end{array}$$

b.
$$\begin{array}{r} 5.213 \\ \times 0.0012 \\ \hline \end{array}$$

SOLUTION 2

a.
$$\begin{array}{r} 5.102 \quad 3 \text{ decimal digits} \\ \times 21.03 \quad 2 \text{ decimal digits} \\ \hline 15306 \\ 5102 \\ 10204 \\ \hline 107.29506 \quad 3 + 2 = 5 \text{ decimal digits.} \end{array}$$

b.
$$\begin{array}{r} 5.213 \quad 3 \text{ decimal digits} \\ \times 0.0012 \quad 4 \text{ decimal digits} \\ \hline 10426 \\ 5213 \\ \hline .0062556 \quad 3 + 4 = 7 \text{ decimal digits.} \end{array}$$

The answer is written as 0.0062556.

PROBLEM 2

Multiply:

a.
$$\begin{array}{r} 3.201 \\ \times 31.02 \\ \hline \end{array}$$

b.
$$\begin{array}{r} 4.132 \\ \times 0.0021 \\ \hline \end{array}$$

B > Multiplying by Powers of 10

In many cases, we have to multiply decimals by **powers** of 10 (10, 100, 1000, etc.). The rules for doing this are very simple. See if you discover a pattern.

$$32.314 \times 10 = 323.14$$

$$32.314 \times 100 = 3231.4$$

$$32.3104 \times 1000 = 32314.$$

Did you find the pattern?

Here is the general rule to multiply by powers of 10.

RULE FOR MULTIPLYING BY A POWER OF 10

To *multiply* a decimal number by 10, 100, 1000, or a higher power of 10, move the decimal point as many places to the *right* as there are *zeros* in the power of 10 being multiplied. (Sometimes you will need to attach additional zeros in order to move the decimal point.)

EXAMPLE 3 Multiplying by powers of 10

Multiply:

a. $41.356 \times 100 = \underline{\hspace{2cm}}$

b. $32.3 \cdot 1000 = \underline{\hspace{2cm}}$

c. $(0.417)(10) = \underline{\hspace{2cm}}$

SOLUTION 3

a. $41.356 \times 100 = 4135.6$ Move the decimal point two places to the right. The answer is 4135.6.

PROBLEM 3

Multiply:

a. $58.12 \times 100 = \underline{\hspace{2cm}}$

b. $43.1 \cdot 1000 = \underline{\hspace{2cm}}$

c. $(10.296)(10) = \underline{\hspace{2cm}}$

(continued)

Answers to PROBLEMS

2. a. 99.29502 b. 0.0086772 3. a. 5812 b. 43,100 c. 102.96

- b. $32.3 \cdot 1000 = 32300$ Move the decimal point three places to the right and attach two additional zeros. The answer is 32,300.
- c. $(0.417)(10) = 4.17$ Move the decimal point one place to the right. The answer should be written as 4.17.

EXAMPLE 4 Multiplying decimals at Burger King

The sign below says that items from the Burger King (BK) value menu cost .99 cents. What will be the cost of 100 items from the BK value menu?

SOLUTION 4 To find the answer, we multiply .99 cents by 100.

$$\begin{aligned} .99 \text{ cents} \times 100 &= (.99 \times 100) \text{ cents} \\ &= 99. \text{ cents} && \text{Move the decimal 2 places.} \\ &= 99 \text{ cents} \end{aligned}$$

So, you can buy 100 BK value menu items for 99 cents!

PROBLEM 4

What will be the cost of 10 items from the BK value menu?



Do you see what the error in the sign is? What they really mean is that one BK value menu item is 99 cents (no decimal). .99¢ is ninety-nine hundredth of a cent, not even a whole penny! This is a common error! Let us discuss the relationship between dollars and cents further.

EXAMPLE 5 Converting cents to dollars and vice versa

- a. If you have 457 cents, how many dollars do you have?
b. If you have \$5.48, how many cents do you have?

SOLUTION 5 We solve these problems by substitution using two facts:

- One cent is one hundredth of a dollar. 1 cent = \$0.01
- One dollar consists of 100 cents. \$1 = 100 cents

Now, we use these two facts and substitution to solve the problems.

a. $457 \text{ cents} = 457 (\$0.01) = \$4.57$
substituting

Thus, if you have 457 cents, you have \$4.57.

b. $\$5.48 = 5.48 \text{ dollars} = 5.48 (100 \text{ cents}) = 548 \text{ cents}$
substituting

Thus, if you have \$5.48 you have 548 cents.

PROBLEM 5

- a. If you have 692 cents, how many dollars do you have?
b. If you have \$7.92, how many cents do you have?

C > Dividing Decimals

We are now ready to do division of decimals. Actually, the division of decimal numbers is very similar to the division of whole numbers. For example, to find the cost per ounce of the tuna in the ad, we need to solve this division problem:

$$\begin{array}{r} \underline{52} \\ 6.5 \end{array} \begin{array}{l} \leftarrow \text{Price (in cents)} \\ \leftarrow \text{Number of ounces} \end{array}$$

Answers to PROBLEMS

4. 9.9¢ 5. a. \$6.92 b. 792 cents



If we multiply the numerator and denominator of this fraction by 10, we obtain

$$\frac{52}{6.5} = \frac{52 \times 10}{6.5 \times 10} = \frac{520}{65} = 8 \quad (\text{cents per ounce})$$

Thus, $\frac{52}{6.5} = 8$, as can be easily checked, since $52 = 6.5 \times 8$. This problem can be shortened by using the following steps.

- Step 1.** Write the problem in the usual long division form. $6.5 \overline{)52}$
- Step 2.** Move the decimal point in the divisor, 6.5, to the right until a whole number is obtained. (This is the same as multiplying 6.5 by 10.) $65 \overline{)52}$
- Step 3.** Move the decimal point in the dividend the *same* number of places as in Step 2. This is the same as multiplying the dividend 52 by 10. Attach zeros if necessary. $65 \overline{)520}$
- Step 4.** Place the decimal point in the answer directly above the new decimal point in the dividend. $65 \overline{)520.}$
- Step 5.** Divide exactly as you would divide whole numbers. (We converted the problem into a familiar one!) The result is 8 cents per ounce, as before. $65 \overline{)520.}$
 $\begin{array}{r} 8. \\ 65 \overline{)520.} \\ \underline{520} \\ 0 \end{array}$

Here is another example: $\frac{1.28}{1.6}$.

- Step 1.** Write the problem in the usual long division form. $1.6 \overline{)1.28}$
- Step 2.** Move the decimal point in the divisor to the right until a whole number is obtained. $16 \overline{)1.28}$
- Step 3.** Move the decimal point in the dividend the *same* number of places as in Step 2. $16 \overline{)12.8}$
- Step 4.** Place the decimal point in the answer directly above the new decimal point in the dividend. $16 \overline{)12.8.}$
- Step 5.** Divide exactly as you would divide whole numbers. $16 \overline{)12.8.}$
 $\begin{array}{r} .8 \\ 16 \overline{)12.8} \\ \underline{12.8} \\ 0 \end{array}$

Thus,

$$\frac{1.28}{1.6} = 0.8$$

EXAMPLE 6 Dividing decimals

Divide $\frac{2.1}{0.035}$.

SOLUTION 6

$$0.035 \overline{)2.100}$$

We moved the decimal point in the divisor (and also in the dividend) three places to the right. When doing this we had to attach two zeros to 2.1.

$$\begin{array}{r} 60. \\ 35 \overline{)2100.} \\ \underline{210} \\ 00 \end{array}$$

We next place the decimal point in the answer directly above the one in the dividend and proceed in the usual manner. The answer is 60; that is,

$$\frac{2.1}{0.035} = 60$$

CHECK $0.035 \times 60 = 2.100$

PROBLEM 6

Divide $\frac{1.4}{0.035}$.

Sometimes it is necessary to write one or more zeros in the quotient. We illustrate this procedure in Example 7.

EXAMPLE 7 Dividing decimalsDivide $\frac{0.0048}{12}$.**SOLUTION 7**

$$\begin{array}{r} 0.\overline{0004} \\ 12 \overline{)0.0048} \\ \underline{48} \\ 0 \end{array}$$

Zeros inserted
The divisor is already a whole number, so we place the decimal point in the answer directly above the one in the dividend and proceed as shown. Thus,

$$\frac{0.0048}{12} = 0.0004$$

CHECK $12 \times 0.0004 = 0.0048$ **PROBLEM 7**Divide $\frac{0.0065}{13}$.**D > Rounding Decimals**

In Examples 6 and 7 the dividend (numerator) was exactly divisible by the divisor (denominator). If this is *not* the case, we must stop the division when a predetermined number of decimal digits is reached and *round* (approximate) the answer. For example, if three cans of soup cost 89¢, what is the cost per can approximated to the nearest cent? The cost will be

$$89 \div 3 \quad \text{or} \quad 3 \overline{)89}$$

$$\begin{array}{r} 6 \\ \underline{18} \\ 29 \\ \underline{27} \\ 2 \end{array}$$

What do we do now? Since we have already obtained the whole part of the answer, we enter a decimal point after the 89 and continue the division until one decimal digit is obtained, as shown.

$$\begin{array}{r} 29.6 \\ 3 \overline{)89.0} \\ \underline{6} \\ 29 \\ \underline{27} \\ 20 \\ \underline{18} \\ 2 \end{array}$$

We now approximate our answer, 29.6, to the nearest cent, that is, to 30¢. Thus, the cost per can will be 30¢. Here are the steps used in rounding numbers.

RULE FOR ROUNDING DECIMAL NUMBERS

- Step 1.** *Underline* the number of digits or places to which you are rounding.
- Step 2.** If the first number to the *right* of the underlined place is 5 or more, *add one* to the underlined number. Otherwise, *do not change* the underlined number.
- Step 3.** *Change* all the numbers to the *right* of the underlined number to zeros if they are to the *left* of the decimal point. Otherwise, simply delete them.

Answers to PROBLEMS

7. 0.0005

Here is the number 23.653 rounded to *two* and *one* decimal places, respectively.

23.653 becomes 23.65 The 3 is deleted because it is less than 5.

23.653 becomes 23.7 The 6 is increased by 1, becoming 7, because the number to the right of the underlining is 5.

EXAMPLE 8 Rounding decimals

Round 234.851 to the specified place value.

- a. the nearest ten. b. one decimal digit (the nearest tenth). c. two decimal digits (the nearest hundredth).

SOLUTION 8

- a. Rounded to the nearest ten, 234.851 becomes 230.
 b. Rounded to one decimal digit, 234.851 becomes 234.9.
 c. Rounded to two decimal digits, 234.851 becomes 234.85.

PROBLEM 8

Round 27.752 to the specified place value.

- a. the nearest ten.
 b. one decimal digit (the nearest tenth).
 c. two decimal digits (the nearest hundredth).

The rule we have just developed can be used to round the answer in division problems. Here is how.

EXAMPLE 9 Rounding quotients

Divide $80 \div 0.14$. (Round the answer to two decimal digits, the nearest hundredth.)

SOLUTION 9

$$0.14 \overline{)8000.}$$

Move the decimal in the dividend and divisor two places to the right, attaching three zeros as shown, so we can round to the required two decimal digits. (Note that $8000 = 8000.000$.)

$$\begin{array}{r} 571.428 \\ 14 \overline{)8000.000} \\ \underline{70} \\ 100 \\ \underline{98} \\ 20 \\ \underline{14} \\ 60 \\ \underline{56} \\ 40 \\ \underline{28} \\ 120 \\ \underline{112} \\ 8 \end{array}$$

Proceed as in the division of whole numbers, until the whole part of the answer, 571, is obtained. Since we are rounding to *two* decimal digits, attach three zeros to the 8000. and continue dividing until *three* decimal digits are obtained, as shown. The answer obtained, 571.428, when rounded to two decimal digits, becomes 571.43. (Since the digit to the *right* of the underlining, 8, was more than 5, we increased the last underlined digit, the 2, by 1.)

PROBLEM 9

Divide $56 \div 0.12$.
 (Round the answer to two decimal digits, the nearest hundredth.)

E > Dividing by Powers of 10

Division of decimals by powers of 10 is very easy. See if you discover the pattern:

$$346.31 \div 10 = 34.631$$

$$346.31 \div 100 = 3.4631$$

$$346.31 \div 1000 = 0.34631$$

Here is the general rule for dividing by a power of 10.

RULE FOR DIVIDING BY A POWER OF 10

To divide a decimal number by 10, 100, 1000, or a higher power of 10, move the decimal point as many places to the *left* as there are zeros in the divisor. (Sometimes it is necessary to prefix additional zeros in order to move the decimal point.)

Answers to PROBLEMS

8. a. 30 b. 27.8 c. 27.75

9. 466.67

EXAMPLE 10 Dividing by powers of 10

Divide:

a. $338.4 \div 100$

b. $2.16 \div 1000$

c. $3.16 \div 10$

SOLUTION 10

a. $338.4 \div 100 = 3.384$

Move the decimal point two places to the left.
The answer is 3.384.

b. $2.16 \div 1000 = 0.00216$

Move the decimal point three places to the left after
prefixing two additional zeros. The answer is 0.00216.

c. $3.16 \div 10 = 0.316$

Move the decimal point one place to the left. The
answer should be written as 0.316.**PROBLEM 10**

Divide:

a. $352.9 \div 100$

b. $3.27 \div 1000$

c. $9.35 \div 10$

F > Applications Involving Decimals

A booklet called *Conservation Payback*, published by Shell, uses division of decimals to find out the time (T) it takes to pay back the cost of an energy-saving measure. This is done by dividing the cost of undertaking the measure by the *amount saved the first year*; that is,

$$T \text{ (time for payback)} = \frac{\text{cost}}{\text{amount saved}}$$

For example, an insulation blanket for your hot water heater costs \$25. The amount saved in electricity the first year is \$20. Thus, the time for payback is

$$\frac{\text{cost}}{\text{amount saved}} = \frac{25}{20} \quad \text{or} \quad \begin{array}{r} 1.25 \\ 20 \overline{)25.00} \\ \underline{20} \\ 50 \\ \underline{40} \\ 100 \\ \underline{100} \\ 0 \end{array}$$

That is, it takes 1.25 years to pay back the cost of the \$25 blanket. We will use this formula in Example 11.

EXAMPLE 11 Conservation by insulation

It is estimated that insulating the walls of a house in Oregon (done by a contractor) costs \$478 and will save \$168 in heating costs the first year. To the nearest tenth of a year, how much time will it take to pay back the total cost?

SOLUTION 11 According to the formula, we must divide the cost of insulating (\$478) by the amount saved the first year (\$168). We carry the division to two decimal places and then round to the nearest tenth.

$$\begin{array}{r} 2.84 \\ 168 \overline{)478.00} \\ \underline{336} \\ 1420 \\ \underline{1344} \\ 760 \\ \underline{672} \\ 88 \end{array}$$

When the answer 2.84 is rounded to the nearest tenth, we obtain $2.\underline{8}4 \rightarrow 2.8$. Thus, it will take about 2.8 years to pay back the \$478 cost.

PROBLEM 11

In Oregon a blanket to insulate a water heater costs \$27. This measure can save \$22 (in electricity) the first year. How long will it take (to the nearest tenth of a year) to pay back the cost of the insulation?

Answers to PROBLEMS

10. a. 3.529 b. 0.00327 c. 0.935 11. 1.2 years

Did you know that you are contributing to global warming when you drive? A gallon of gasoline weighs just over 6 pounds and when burned, the carbon in it combines with oxygen to produce about 19 pounds of CO_2 . But don't forget to add the energy that went into making and distributing the fuel, making the total global warming pollution about **25 pounds of CO_2** per gallon. Your personal emissions depend on your car's efficiency and the miles you drive. Let us see how in Example 12.

Source: <http://www.fightglobalwarming.com/page.cfm?tagID=263>.

GREEN MATH

EXAMPLE 12 Car pollution

If your car makes 20 miles per gallon and you drive 50 miles each day:

- How many gallons of gas do you use each day?
- How much CO_2 does your car produce each day?
- Assume you drive 300 days each year, how much CO_2 does your car produce in a year?

SOLUTION 12

- To find how many gallons you use each day, divide 50 by 20. You can use long division to do this, but note that $\frac{50}{20} = \frac{5}{2} = 2\frac{1}{2}$ gallons.
- Each gallon of gas produces 25 pounds of CO_2 . So $2\frac{1}{2}$ gallons produce

$$25 \times 2\frac{1}{2} = 25 \times 2.5$$

$$\begin{array}{r} 25 \\ \times 2.5 \\ \hline 125 \\ 50 \\ \hline 625 \end{array}$$

1 decimal digit

1 decimal digit

Thus, your car produces 62.5 pounds of CO_2 each day.

- If your car produces 62.5 pounds of CO_2 each day, in 300 days you produce 300×62.5 pounds of CO_2 . Save time! Set up the multiplication as shown. Multiply 300×62.5 and add the 2 zeros. (You can think of this as multiplying $3 \times 100 \times 62.5$.)

$$\begin{array}{r} 62.5 \\ \times 300 \\ \hline 187500 \end{array}$$

1 decimal

1 decimal

So, your car produces 18,750 pounds of CO_2 in a year.

PROBLEM 12

If your car makes 40 miles per gallon and you still drive 50 miles each day:

- How many gallons of gas do you use each day?
- How much CO_2 does your car produce each day?
- Assume you drive 300 days each year, how much CO_2 does your car produce in a year?

Note that if your car makes 40 miles per gallon instead of 20 miles per gallon, you cut emissions in half!

See Exercises 77–83 for more cost and pollution saving tips!



Calculator Corner

Multiplying and dividing decimals using a calculator really simplifies things. You do not have to bother with the placement of the decimal point in the final answer at all! To do Example 2, part **a**: Multiply 5.102 by 21.03 by pressing

5 . 1 0 2 \times 2 1 . 0 3 ENTER and the final answer, 107.29506, will appear in the display. Similarly, to complete the division $80 \div 0.14$ (rounded to two decimal digits, as in Example 9), we enter 8 0 \div . 1 4 ENTER. The display shows 571.42857, giving 571.43 when rounded to two decimal digits.

Answers to PROBLEMS

12. a. 1.25 b. 31.25 c. 9375



> Practice Problems > Self-Tests
> Media-rich eBooks > e-Professors > Videos

> Exercises 3.2

< A > Multiplying Decimals In Problems 1–16, multiply.

- | | | | |
|------------------------|-----------------------|-------------------------|-------------------------|
| 1. $0.5 \cdot 0.7$ | 2. $0.9 \cdot 0.2$ | 3. $0.8 \cdot 0.8$ | 4. $0.7 \cdot 0.9$ |
| 5. $0.005 \cdot 0.07$ | 6. $0.012 \cdot 0.3$ | 7. $9.2 \cdot 0.613$ | 8. $0.514 \cdot 7.4$ |
| 9. $8.7 \cdot 11$ | 10. $78.1 \cdot 108$ | 11. $7.03 \cdot 0.0035$ | 12. $8.23 \cdot 0.025$ |
| 13. $3.0012 \cdot 4.3$ | 14. $6.1 \cdot 2.013$ | 15. $0.0031 \cdot 0.82$ | 16. $0.51 \cdot 0.0045$ |

< B > Multiplying by Powers of 10 In Problems 17–26, multiply.

- | | | | | |
|------------------------|----------------------|----------------------|-----------------------|------------------------|
| 17. $42.33 \cdot 10$ | 18. $36.37 \cdot 10$ | 19. $19.5 \cdot 100$ | 20. $18.3 \cdot 100$ | 21. $32.89 \cdot 1000$ |
| 22. $35.35 \cdot 1000$ | 23. $0.48 \cdot 10$ | 24. $0.37 \cdot 10$ | 25. $0.039 \cdot 100$ | 26. $0.048 \cdot 100$ |

< C > Dividing Decimals In Problems 27–36, divide.

- | | | | | |
|------------------------|------------------------|------------------------|------------------------|----------------------|
| 27. $15 \overline{)9}$ | 28. $48 \overline{)6}$ | 29. $5 \overline{)32}$ | 30. $8 \overline{)36}$ | 31. $8.5 \div 0.005$ |
| 32. $4.8 \div 0.003$ | 33. $4 \div 0.05$ | 34. $18 \div 0.006$ | 35. $2.76 \div 60$ | 36. $31.8 \div 30$ |

< D > Rounding Decimals In Problems 37–46, round the numbers to the specified place value or indicated number of digits.

- | | | |
|------------------------------------|-------------------------------|--------------------------------------|
| 37. 34.8 to the nearest ten | 38. 505.6 to the nearest ten | 39. 96.87 to the nearest hundred |
| 40. 241.2 to the nearest hundred | 41. 3.15 to one decimal digit | 42. 0.415 to two decimal digits |
| 43. 7.81 to the nearest ten | 44. 7.81 to the nearest tenth | 45. 338.123 to the nearest hundredth |
| 46. 338.123 to the nearest hundred | | |

< E > Dividing by Powers of 10 In Problems 47–50, divide.

- | | | | |
|--------------------|---------------------|---------------------|-----------------------|
| 47. $7.8 \div 100$ | 48. $3.5 \div 1000$ | 49. $0.05 \div 100$ | 50. $0.061 \div 1000$ |
|--------------------|---------------------|---------------------|-----------------------|

In Problems 51–60, divide and round the answer to two decimal digits, the nearest hundredth.

- | | | | | |
|---------------------------|-----------------------|----------------------|----------------------------|------------------------------|
| 51. $1 \div 3$ | 52. $20 \div 7$ | 53. $0.06 \div 0.70$ | 54. $0.05 \div 0.90$ | 55. $12.243 \overline{)2.8}$ |
| 56. $20 \overline{)5.47}$ | 57. $8.156 \div 1000$ | 58. $7.355 \div 100$ | 59. $20 \overline{)0.545}$ | 60. $60 \overline{)0.386}$ |

< F > Applications Involving Decimals

- | | |
|--|---|
| 61. <i>Cost of filling up</i> What is the cost of filling a 13.5-gallon gas tank, if gasoline costs \$2.61 per gallon? Answer to the nearest cent. | 62. <i>Cost of filling up</i> What is the cost of filling a 14.5-gallon gas tank, if gasoline costs \$3.32 per gallon? |
| 63. <i>Cost of operating a central air conditioner</i> The cost of operating a central air conditioner (used 24 hours a day) is about \$0.67 per hour. How much does it cost to
a. operate the air for 24 hours?
b. operate the air for a month (30 days)? | 64. <i>Cost of operating a fluorescent lightbulb</i> The cost of operating a 22-watt fluorescent lightbulb (used 12 hours a day) is about \$0.0308 per hour. To the nearest cent, how much does it cost to
a. operate the bulb for 12 hours?
b. operate the bulb for 30 days (use the result from a)? |

Gas meters In Section 1.1, we learned how to read electric meters. Gas meters are read in the same way, and the result is in therms.

- 65.** If you use 30 therms of gas costing \$1.8 per therm, what is the total cost of your gas?
- 67.** Suppose you use 48 therms of gas. If the first 15 therms cost \$1.09 per therm and the remainder cost \$1.27 per therm, what is the total gas bill?
- 69.** *Van renting costs* The daily cost of renting a 15-foot van from Ryder® is \$69.99 plus 49 cents per mile. If you rent a van for 3 days and travel 348 miles, what is the total rental cost?
- 66.** If you use 50 therms of gas costing \$1.27 per therm, what is the total cost of your gas?
- 68.** Suppose you use 50 therms of gas. If the first 15 therms cost \$1.10 per therm and the remainder cost \$1.30 per therm, what is the total gas bill?
- 70.** *Van renting costs* A 20-foot truck rents for \$79.99 per day plus 49 cents per mile. If you rent a truck for 3 days and travel 257 miles, what is the total rental cost?

Downloading times (text, pictures, video) The table gives the estimated download time for text, pictures, and videos. Since Web files on the Internet are compressed, to obtain the approximate real-world download time we divide these times by 2.

- 71.** Find the estimated download time for text using a 9600 bps (bits per second) modem.
- 72.** Find the estimated download time for a picture using a 14,400 bps modem.
- 73.** Find the estimated download time for text using a 28,800 bps modem.
- 74.** Find the estimated download time for video using a 28,800 bps modem.
- 75.** What is the time difference when downloading a video with a 9600 bps modem as opposed to a 14,400 bps modem?

Modem Speed	Text (2.2 KB)	Picture (300 KB)	Video (2.4 MB)
2400 bps	7.33 sec	16.6 min	2.42 hr
9600 bps	1.83 sec	4.17 min	33.3 min
14,400 bps	1.22 sec	2.78 min	22.2 min
28,800 bps	0.61 sec	1.39 min	11.1 min

- 76.** What is the time difference when downloading a picture with a 14,400 bps modem as opposed to a 28,800 bps modem?

>>> Applications: Green Math

The more fuel you burn, the more pollution you create! **25 pounds (lb) of CO₂ per gallon!** How much does it cost and how much pollution is created? In Exercises 77–83, complete the columns and find the average fuel used (column 2), the approximate CO₂ created (column 3), and the cost (column 4).

The Annual Cost of Fuel Efficiency and the Pollution It Causes

Average Gas Mileage	Average Fuel Used (Based on 12,000 Miles per Year)	Approximate CO ₂ Pollution	Approximate Cost (Based on \$2.30/Gallon)
77. 50 mpg			
78. 40 mpg			
79. 30 mpg			
80. 25 mpg			
81. 20 mpg			
82. 15 mpg			
83. 10 mpg			

What can you do to save on gas and cut pollution? You can buy a *hybrid* or more efficient car if you can afford it. Otherwise, do Exercises 84–86 and see.

- 84.** *Eliminate unnecessary trips* Walk, use public transportation, or carpool and save up to 30 gallons of gas per year! What are the savings if gas costs \$2.30 a gallon? How much pollution at 25 pounds of CO₂ per gallon do you save?
- 85.** *Reduce aggressive driving!* Rapid acceleration and braking reduces gas mileage and can burn an extra 125 gallons of gas per year. How much can you save at \$2.30 per gallon and how much pollution at 25 pounds of CO₂ per gallon can be eliminated?
- 86.** *Keep your car tuned!* You can save up to 165 gallons of gas per year! How much money at \$2.30 per gallon and how much pollution at 25 pounds of CO₂ per gallon is avoided?

In Problems 87–91, use the formula preceding Example 11 to find the payback time. Give answers to the nearest tenth of a year.

Conservation Measure	Cost (Do It Yourself)	Savings (1st Year)
87. Add storm windows/door (Connecticut)	\$790	\$155
88. Insulate basement walls (Connecticut)	\$621	\$360
89. Caulk around windows (Texas)	\$41	\$18
90. Increase attic insulation (Texas)	\$260	\$98
91. Insulate floors (Oregon)	\$315	\$92

92. *Recycling* Recycling one aluminum can saves the equivalent of half a gallon of gasoline. How many gallons of gasoline are saved if you recycle seven aluminum cans?

Source: <http://members.aol.com>.

94. *Worms* One pound of red worms can consume half a pound of food waste every day. How many pounds of food waste can 15 pounds of red worms consume? If you have 9 pounds of food waste, how many pounds of red worms do you need to consume the 9 pounds?

Source: <http://www.ilacsd.org>.

93. *Save on those diapers* A cloth diaper washed at home costs 3¢ per use. A disposable diaper costs 22¢ per use. How much do you save per use? If a typical baby uses 10,000 diapers, how much can you save (in dollars)?

Source: <http://members.aol.com>.

Using Your Knowledge

Anthropology The relationship between the length of various bones and height is so precise that anthropological detectives with only a dried bone as a clue can determine about how tall a person was. The chart shows this relationship for persons whose height is between 60 and 85 inches.

Height (Inches)	
Male	Female
$(2.89 \times \text{humerus}) + 27.81$	$(2.75 \times \text{humerus}) + 28.14$
$(3.27 \times \text{radius}) + 33.83$	$(3.34 \times \text{radius}) + 31.98$
$(1.88 \times \text{femur}) + 32.01$	$(1.95 \times \text{femur}) + 28.68$
$(2.38 \times \text{tibia}) + 30.97$	$(2.35 \times \text{tibia}) + 22.439$

For example, suppose a 16.2-inch humerus bone from a human male is found. The man's former height is determined as follows:

$$(2.89 \times 16.2) + 27.81 = 46.82 + 27.81 = 74.63 \text{ inches}$$

(We rounded the product 2.89×16.2 to two decimal places.)

Anthropology Use the formulas in the chart to find the person's height. Round answers to the nearest tenth of an inch.

- | | |
|---|--|
| 95. 16.2-inch tibia (male) | 96. 12.5-inch tibia (female) |
| 97. 8.25-inch radius (female) | 98. 10.3-inch radius (male) |
| 99. 18.8-inch femur (male) | 100. 16-inch femur (female) |
| 101. 15.9-inch humerus (male) | 102. 12.75-inch humerus (female) |
| 103. <i>Longest bone</i> The longest recorded human bone was the femur of the German giant Constantine. It measured 29.9 inches. Use the chart to find out his height. (He was actually 105 inches tall.) What's wrong? Read the last sentence above the chart. | 104. <i>Height for Robert Wadlow</i> The femur of Robert Wadlow, the tallest man on record, measured 29.5 inches. How tall was he according to the table? (He was actually 107 inches tall.) |

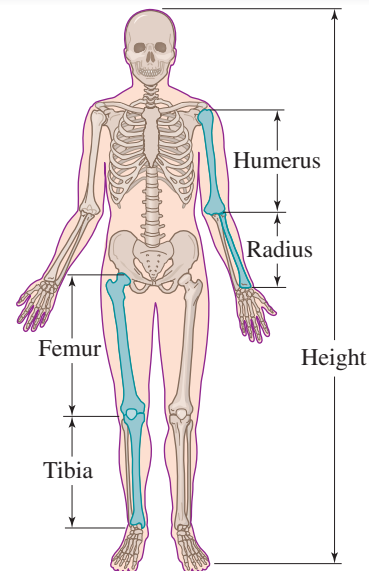

>>> Write On

- 105.** Write in your own words the procedure you use to round a decimal.
- 106.** Write in your own words the procedure you use to change dollars to cents.
- 107.** Write in your own words the procedure you use to change cents to dollars.

>>> Concept Checker

Fill in the blank(s) with the correct word(s), phrase, or mathematical phrase.

- | | | |
|--|-----------------|--------------|
| 108. When multiplying decimals, the number of decimal digits in the product is the _____ of the number of decimal digits in the factors. | subtract | sum |
| 109. To multiply a decimal number by 10, 100, 1000 , or a higher power of 10, move the decimal point as many places to the _____ as there are _____ in the power of 10 being multiplied. | divisor | right |
| 110. When rounding a decimal number, if the first number to the _____ of the underlined place is 5 or more , _____ one to the underlined number. | left | add |
| 111. To divide a decimal number by 10, 100, 1000, or a higher power of 10, move the decimal point as many places to the _____ as there are zeros in the _____. | zeros | |

>>> Mastery Test

- 112.** Divide:
- $449.6 \div 100$
 - $3.14 \div 1000$
 - $4.23 \div 10$
- 113.** Divide: $90 \div 0.14$ (Round the answer to two decimal digits.)
- 114.** Round 587.752 to
- the nearest ten.
 - one decimal digit.
 - two decimal digits.
- 115.** Divide: $\frac{0.0060}{12}$
- 116.** Divide: $\frac{2.7}{0.045}$
- 117.** Multiply:
- 32.423×10
 - $48.4 \cdot 1000$
 - $(0.328)(100)$
- 118.** Multiply:
- 6.103×21.02 (Round the answer to two decimal digits.)
 - 3.214×0.0021 (Round the answer to two decimal digits.)
- 119.** Multiply:
- 4.41×3.2
 - 14.724×5.1
- 120.** According to the Sacramento Municipal Utilities District, you can save \$48 per year in electricity costs if you buy an Energy Star clothes dryer. If the dryer costs \$360, how much time will it take to pay back the total cost?

>>> Skill Checker

Find the missing number.

121. $\frac{2}{5} = \frac{?}{10}$

122. $\frac{3}{10} = \frac{?}{100}$

123. $\frac{2}{125} = \frac{?}{1000}$

3.3

Fractions and Decimals

▶ Objectives

You should be able to:

- A > Write a fraction as an equivalent decimal.
- B > Write a terminating decimal as a fraction in reduced form.
- C > Write a repeating decimal as a fraction.
- D > Solve applications involving the concepts studied.

▶ To Succeed, Review How To . . .

1. Write a fraction as an equivalent one with a specified denominator. (pp. 125–127)
2. Write a fraction in reduced form. (pp. 127–129)
3. Write the word name for a decimal. (p. 211)

▶ Getting Started

The sign on the left shows the price of 1 gallon of gasoline using the fraction, $\frac{9}{10}$. However, the sign on the right shows this price as the decimal 0.9. If we are given a fraction, we can sometimes find its decimal equivalent by multiplying the numerator and denominator by a number that will cause the denominator to be a power of 10 (10, 100, 1000, etc.) and then writing the decimal equivalent. For example,



$$\frac{2}{5} = \frac{2 \cdot 2}{5 \cdot 2} = \frac{4}{10} = 0.4$$

$$\frac{3}{4} = \frac{3 \cdot 25}{4 \cdot 25} = \frac{75}{100} = 0.75$$

$$\frac{3}{125} = \frac{3 \cdot 8}{125 \cdot 8} = \frac{24}{1000} = 0.024$$

A > Writing Fractions as Decimals

These conversions can *always* be made by *dividing* the numerator by the denominator. Thus,

$$\frac{2}{5} = 2 \div 5 \quad \text{or} \quad \begin{array}{r} 0.4 \\ 5 \overline{)2.0} \\ \underline{20} \\ 0 \end{array}$$

$$\frac{3}{4} = 3 \div 4 \quad \text{or} \quad \begin{array}{r} 0.75 \\ 4 \overline{)3.00} \\ \underline{28} \\ 20 \\ \underline{20} \\ 0 \end{array}$$

That is, $\frac{2}{5} = 0.4$.

That is, $\frac{3}{4} = 0.75$.

$$\frac{3}{125} = 3 \div 125 \quad \text{or} \quad \begin{array}{r} 0.024 \\ 125 \overline{)3.000} \\ \underline{250} \\ 500 \\ \underline{500} \\ 0 \end{array} \quad \text{That is, } \frac{3}{125} = 0.024.$$

Here is the rule:

TO CONVERT A FRACTION TO A DECIMAL

Divide the numerator by the denominator.

EXAMPLE 1 Converting fractions to decimals

Write as a decimal.

a. $\frac{4}{5}$

b. $\frac{11}{40}$

c. $3\frac{11}{40}$

SOLUTION 1

a. $\frac{4}{5} = 4 \div 5$ or
$$\begin{array}{r} 0.8 \\ 5 \overline{)4.0} \\ \underline{40} \\ 0 \end{array}$$

Hence $\frac{4}{5} = 0.8$.

b. $\frac{11}{40} = 11 \div 40$ or
$$\begin{array}{r} 0.275 \\ 40 \overline{)11.000} \\ \underline{80} \\ 300 \\ \underline{280} \\ 200 \\ \underline{200} \\ 0 \end{array}$$

Hence $\frac{11}{40} = 0.275$.

c. Recall that $3\frac{11}{40} = 3 + \frac{11}{40}$
 $= 3 + 0.275 = 3.275$

PROBLEM 1

Write as a decimal.

a. $\frac{3}{5}$

b. $\frac{3}{40}$

c. $5\frac{3}{40}$

In all the previous examples you obtained a **terminating decimal** for an answer; that is, when you divided the numerator by the denominator, you eventually got a remainder of 0. However, this is not always the case. For example, to write $\frac{1}{6}$ as a decimal, we proceed as before:

$$\frac{1}{6} = 1 \div 6 \quad \text{or} \quad \begin{array}{r} 0.166 \\ 6 \overline{)1.000} \\ \underline{6} \\ 40 \\ \underline{36} \\ 40 \\ \underline{36} \\ 4 \end{array}$$

If the division is carried further, you will continue getting 6's in the quotient. The decimal equivalent for $\frac{1}{6}$ is a **repeating decimal**. The group of repeating digits is called the **repetend**. The answer can be written as

$$\frac{1}{6} = 0.1666 \dots$$

or by writing a bar called a vinculum over the repetend, like this:

$$\frac{1}{6} = 0.1\overline{6}$$

(The bar means the 6 repeats, so 6 is the repetend.)

EXAMPLE 2 Converting fractions to decimals

Write $\frac{1}{7}$ as a decimal.

PROBLEM 2

Write $\frac{2}{7}$ as a decimal.

(continued)

Answers to PROBLEMS

1. a. 0.6 b. 0.075 c. 5.075

2. $0.\overline{285714}$

SOLUTION 2

$$\frac{1}{7} = 1 \div 7 \quad \text{or} \quad \begin{array}{r} 0.142857 \\ 7 \overline{)1.0} \\ \underline{7} \\ 30 \\ \underline{28} \\ 20 \\ \underline{14} \\ 60 \\ \underline{56} \\ 40 \\ \underline{35} \\ 50 \\ \underline{49} \\ 1 \end{array}$$

Note that the remainder 1 is equal to the original dividend. This indicates that the quotient repeats itself. Thus, $\frac{1}{7} = 0.142857$.

Note that in Example 2, we could have rounded the answer to two decimal digits. We then would obtain $\frac{1}{7} \approx 0.14$, where the sign \approx means “is approximately equal to.”

B > Writing Terminating Decimals as Fractions

We are now ready to convert decimals to fractions. Do you remember the word name for 0.2?

0.2 is two-tenths

$$\text{Thus, } 0.2 = \frac{2}{10} = \frac{1}{5}$$

0.11 is eleven-hundredths

$$\text{Thus, } 0.11 = \frac{11}{100}$$

0.150 is one hundred fifty thousandths

$$\text{Thus, } 0.150 = \frac{150}{1000} = \frac{3}{20}$$

Note that 0.2 has 2 as numerator and 10 as denominator. Also, 0.11 has 11 as numerator and 100 as denominator, and 0.150 has 150 as numerator and 1000 as denominator. Here is the rule:

RULE FOR CONVERTING A TERMINATING DECIMAL TO A FRACTION

1. Write the digits to the *right* of the decimal point as the *numerator* of the fraction.
2. The *denominator* is a 1 followed by as many zeros as there are decimal digits in the decimal.
3. Reduce the fraction.

EXAMPLE 3 Converting terminating decimals to fractions

Write each decimal as a reduced fraction.

a. 0.025

b. 0.0175

SOLUTION 3

a. 0.025 is twenty-five thousandths. Thus

$$\underbrace{0.025}_{\substack{\uparrow \\ \text{3 digits}}} = \frac{25}{\underbrace{1000}_{\substack{\uparrow \\ \text{3 zeros}}}} = \frac{1}{40}$$

PROBLEM 3

Write each decimal as a reduced fraction.

a. 0.050

b. 0.0350

Answers to PROBLEMS

3. a. $\frac{1}{20}$ b. $\frac{7}{200}$

b. 0.0175 is one hundred seventy-five ten-thousandths. Thus

$$0.0175 = \frac{175}{10,000} = \frac{7}{400}$$

↑ 4 digits ↑ 4 zeros

In case the decimal has a whole number part, convert the decimal part to a fraction first and then add the whole number part. For example, to write 3.17 as a fraction, we write

$$3.17 = 3 + 0.17 = 3 + \frac{17}{100} = 3\frac{17}{100} = \frac{317}{100}$$

Note that 3.17 is three and seventeen hundredths; that is, $3.17 = 3\frac{17}{100} = \frac{317}{100}$. What do you think 8.91 is? $\frac{891}{100}$, of course. You can use this idea in Example 4.

EXAMPLE 4 Converting terminating decimals to fractions

Write each as a reduced fraction.

a. 2.19

b. 4.15

SOLUTION 4

a. 2.19 is two and nineteen hundredths. Thus,

$$2.19 = 2 + \frac{19}{100} = 2\frac{19}{100} = \frac{219}{100}$$

b. 4.15 is four and fifteen hundredths. Thus,

$$4.15 = 4 + \frac{15}{100} = 4 + \frac{3}{20} = 4\frac{3}{20} = \frac{83}{20}$$

PROBLEM 4

Write each as a reduced fraction.

a. 1.17

b. 4.35

C > Writing Repeating Decimals as Fractions

Can we write a repeating decimal as a fraction? Of course! Here are some examples; you can check them by division. See if you can find a pattern:

$$0.\overline{3} = \frac{3}{9} = \frac{1}{3}$$

$$0.\overline{61} = \frac{61}{99}$$

$$0.\overline{123} = \frac{123}{999} = \frac{41}{333}$$

The rule for making this conversion is given next. Note that this rule applies to decimals that repeat *immediately* after the decimal point—that is, *pure repeating decimals* such as $0.333\dots = 0.\overline{3}$, $0.878787\dots = 0.\overline{87}$ —but not to decimals such as $0.1666\dots = 0.1\overline{6}$.

RULE FOR CONVERTING A PURE REPEATING DECIMAL TO A FRACTION

1. Write the *repeating part* as the *numerator* of the fraction.
2. The *denominator* consists of *as many nines as there are digits in the repetend* (the part that repeats).

For example,

$$0.\overline{6} = \frac{6}{9} = \frac{2}{3}$$

↑ One digit ↑ One nine

Answers to PROBLEMS

4. a. $\frac{117}{100}$ b. $\frac{87}{20}$

$$0.\overline{16} = \frac{16}{99}$$

Two digits Two nines

EXAMPLE 5 Converting repeating decimals to fractions

Write each decimal as a reduced fraction.

a. $0.\overline{43}$

b. $0.\overline{102}$

SOLUTION 5

a. $0.\overline{43} = \frac{43}{99}$

b. $0.\overline{102} = \frac{102}{999} = \frac{34}{333}$

PROBLEM 5

Write each decimal as a reduced fraction.

a. $0.\overline{41}$

b. $0.\overline{105}$

D > Applications Involving Decimal Parts of Numbers

As we have shown, decimal numbers can be written as fractions and hence can represent a part of some quantity. For example, if we wish to find out what decimal part of 12 is 3, we proceed like this:

What decimal part d of 12 is 3?

$$d \times 12 = 3$$

$$d = 3 \div 12 = 12 \overline{)3.0}$$

$$\begin{array}{r} 0.25 \\ 12 \overline{)3.0} \\ \underline{24} \\ 60 \\ \underline{60} \\ 0 \end{array}$$

Divide on both sides by 12.

Thus, 3 is 0.25 of 12.

CHECK $0.25 \times 12 = 3$.**EXAMPLE 6** Finding the decimal part of a number

What decimal part of 16 is 5?

SOLUTION 6What decimal part d of 16 is 5?

$$d \times 16 = 5$$

$$d = 5 \div 16 \quad \text{Divide on both sides by 16.}$$

$$0.3125$$

$$= 16 \overline{)5.0000}$$

$$\begin{array}{r} 48 \\ \underline{20} \\ 16 \\ \underline{40} \\ 32 \\ \underline{80} \\ 80 \\ \underline{0} \end{array}$$

Thus, 5 is 0.3125 of 16, as can be easily checked, since $0.3125 \times 16 = 5$.**PROBLEM 6**

What decimal part of 16 is 7?

Answers to PROBLEMS

5. a. $\frac{41}{99}$ b. $\frac{35}{333}$ 6. 0.4375

Have you had breakfast at McDonald's lately? Example 7 will give you an idea of how much money a restaurant makes on breakfast.

EXAMPLE 7 Finding the decimal part of a number

A restaurant brings in \$131,600 a year for breakfasts alone! If the total take is \$940,000 a year, what decimal part of the \$940,000 is for breakfasts?

SOLUTION 7 In this problem, we want to know
 What part of the \$940,000 is for breakfasts?

$$\begin{aligned} \square \times 940,000 &= 131,600 \\ \square &= \frac{131,600}{940,000} \\ &= \frac{1316}{9400} \\ &= \frac{329}{2350} \\ &= \frac{7}{50} \end{aligned}$$

We now divide 7 by 50.

$$\begin{array}{r} 0.14 \\ 50 \overline{)7.00} \\ \underline{50} \\ 200 \\ \underline{200} \\ 0 \end{array}$$

Thus, 0.14 is the decimal part of the \$940,000 spent for breakfast. This means that \$0.14 of every dollar spent at this restaurant is for breakfast.

PROBLEM 7

A certain restaurant brings in \$128,000 a year for breakfasts. Its total sales amount to \$800,000 a year. What part of the \$800,000 is for breakfasts?

McDonald's does not release typical breakfast figures, but it has been estimated that if annual total sales in a restaurant are \$2.5 million, breakfast sales are \$750,000

$$\text{or } \frac{750,000}{2,500,000} = \frac{75}{250} = 0.30.$$

This means that of every dollar spent in the restaurant 0.30 or 30 cents are for breakfast. Check this!

Source: <http://tinyurl.com/ppuv6b>.

GREEN MATH

EXAMPLE 8 Bang for your buck (return on investment, ROI)

Use the table to find the ROI, $\frac{\text{Savings}}{\text{Added cost}}$ and write it as a reduced fraction and as a two-decimal digit when you install:

- a. Solar path and garden lights.
- b. Windows.
- c. Which is a better return on your investment?

GREEN Remodel

	Added Cost	Annual SAVINGS
Solar path and garden lights	\$375	\$176
Windows	\$700	\$300
Skylights	\$70	\$30
Insulated walls	\$750	\$300

SOLUTION 8

- a. $\frac{176}{375}$. Dividing 176 by 375 (rounded to two places), we get 0.47
- b. $\frac{300}{700} = \frac{3}{7} \approx 0.43$ (Verify this!)
- c. The solar path and garden lights, 0.47 is a better ROI than 0.43

Note that it would be more difficult to compare the fractions $\frac{176}{375}$ and $\frac{3}{7}$, so we converted them to decimals!

$$\begin{array}{r} 0.469 \approx 0.47 \\ 375 \overline{)176.000} \\ \underline{-150} \\ 260 \\ \underline{-225} \\ 350 \\ \underline{-337} \\ 125 \end{array}$$

PROBLEM 8

Find the ROI as a reduced fraction and as a two-decimal digit when you install:

- a. Skylights
- b. Insulated walls
- c. Which is a better return on your investment?

Answers to PROBLEMS

7. 0.16 8. a. $\frac{30}{70} = \frac{3}{7} \approx 0.43$ b. $\frac{300}{750} = \frac{2}{5} = 0.40$ c. The skylights (0.43 against 0.40)



Calculator Corner

To convert a fraction to a decimal using a calculator is very simple. Thus, to write $\frac{4}{5}$ as a decimal (Example 1), we simply recall that $\frac{4}{5}$ means $4 \div 5$. Pressing **4** **÷** **5** **ENTER** will give us the correct answer, 0.8. (Most calculators do not write the zero to the left of the decimal in the final answer.) You can also do Example 2 using division.

> Exercises 3.3



> Practice Problems > Self-Tests
> Media-rich eBooks > e-Professors > Videos

< A > Writing Fractions as Decimals In Problems 1–10, write as a decimal.

- | | | | | |
|--------------------|-------------------|--------------------|-------------------|-------------------|
| 1. $\frac{1}{2}$ | 2. $\frac{2}{5}$ | 3. $\frac{11}{16}$ | 4. $\frac{7}{40}$ | 5. $\frac{9}{20}$ |
| 6. $\frac{15}{16}$ | 7. $\frac{9}{10}$ | 8. $\frac{3}{100}$ | 9. $\frac{1}{4}$ | 10. $\frac{3}{8}$ |

In Problems 11–20, write as a decimal (round to two decimal digits).

- | | | | | |
|--------------------|-------------------|-------------------|--------------------|---------------------|
| 11. $\frac{5}{6}$ | 12. $\frac{7}{6}$ | 13. $\frac{3}{7}$ | 14. $\frac{7}{12}$ | 15. $\frac{8}{3}$ |
| 16. $\frac{11}{6}$ | 17. $\frac{1}{3}$ | 18. $\frac{2}{3}$ | 19. $\frac{2}{11}$ | 20. $\frac{12}{11}$ |

< B > Writing Terminating Decimals as Fractions In Problems 21–28, write as a reduced fraction.

- | | | | | |
|-----------|----------|----------|----------|-----------|
| 21. 0.8 | 22. 0.9 | 23. 0.19 | 24. 0.20 | 25. 0.030 |
| 26. 0.060 | 27. 3.10 | 28. 2.16 | | |

< C > Writing Repeating Decimals as Fractions In Problems 29–34, write as a reduced fraction.

- | | | |
|------------------|------------------|------------------|
| 29. $0.\bar{5}$ | 30. $0.\bar{3}$ | 31. $0.2\bar{1}$ |
| 32. $0.\bar{19}$ | 33. $0.\bar{11}$ | 34. $0.\bar{44}$ |

< D > Applications Involving Decimal Parts of Numbers

Solve.

- | | |
|--|---|
| 35. What decimal part of 8 is 3? | 36. What decimal part of 16 is 9? |
| 37. What decimal part of 1.5 is 37.5? | 38. What decimal part of 2.3 is 36.8? |
| 39. Find a number such that 0.25 of it is 1.2. | 40. Find a number such that 0.5 of it is 1.6. |
| 41. Find 2.5 of 14. | 42. Find 0.33 of 60. |

>>> Applications

43. *Batting averages* The batting average of a baseball player is obtained by dividing the number of hits by the number of times at bat. Find the batting average of a player who has gotten 1 hit in 3 at-bats (round the answer to the nearest thousandth).
44. *Batting averages* Find the batting average of a player with 5 hits in 14 at-bats (round the answer to the nearest thousandth). (*Hint:* See Problem 43.)
45. *Football completions* On September 21, 1980, Richard Todd attempted 59 passes and completed 42. His completion average was $42 \div 59$. Write this number as a decimal rounded to the nearest tenth.
46. *Football completions* Find the completion average for Ken Anderson, who completed 20 out of 22 passes in a game between Cincinnati and Pittsburgh on November 10, 1974. Round the answer to the nearest tenth.

Source: Football.com.

- 47. Wheat cost** If 11 pounds of wheat cost \$24, what is the cost per pound? (Round the answer to the nearest cent.)
- 49. Sunny days in Little Rock** In Little Rock, Arkansas, $\frac{5}{8}$ of the days of the year are sunny. Write $\frac{5}{8}$ as a decimal.
- 51. Sleeping pill consumption** Sleeping pills are taken by $\frac{1}{18}$ of all Americans at least once a week. Write this fraction as a decimal. (Round the answer to the nearest thousandth.)
- 53. Toilet flushing** The average American home uses 60 gallons of water a day, of which 29 are spent in flushing the toilet. Write $\frac{29}{60}$ as a decimal. (Round the answer to the nearest hundredth.)
- 48. Rainy days in Hawaii** In Mt. Waialeale, Hawaii, $\frac{9}{10}$ of the days of the year are rainy. Write $\frac{9}{10}$ as a decimal.
- 50. A headache problem** Here are some interesting statistics about headaches.
- Migraine headaches strike $\frac{1}{8}$ of all Americans. Write $\frac{1}{8}$ as a decimal.
 - Two-thirds of the victims are women. Write $\frac{2}{3}$ as a decimal. (Round the answer to the nearest hundredth.)
 - If both parents suffer migraine headaches, three-quarters of their children will. Write $\frac{3}{4}$ as a decimal.
- 52. False teeth** One American in six wears a full set of false teeth. Write $\frac{1}{6}$ as a decimal, rounded to the nearest hundredth.
- 54. Dirty words in college** The average college student throws in a dirty word for every 11 clean ones. Write $\frac{1}{11}$ as a decimal. (Round the answer to the nearest thousandth.)

Applications: Green Math

In Exercises 55–60, follow the procedure of Example 8 to find the ROI, $\frac{\text{Savings}}{\text{Added cost}}$, and then write the result as a reduced fraction and as a two-digit decimal when you install:

GREEN Remodel	Added Cost	Annual SAVINGS
55. Clothes washer	\$300	\$72
56. Recycled mulch	\$172	\$38
57. Ceiling fans	\$300	\$60
58. Insulate attics and ceilings	\$600	\$120
59. Heat pumps/AC	\$1,000	\$200
60. Sun tubes	\$300	\$45

FICO scores Do you know what your FICO (Fair Isaac Credit Organization) score is? “When you apply for credit—whether for a credit card, a car loan, or a mortgage—lenders want to know what risk they’d take by loaning money to you. FICO scores are the credit scores most lenders use to determine your credit risk. You have three FICO scores, one for each of the three credit bureaus: Experian, TransUnion, and Equifax.”

Source: <http://www.myfico.com>.

The diagram shows the fraction that makes up each of the categories in your FICO score. In Problems 61–64, write the fraction for the specified category as a decimal.

- Payment history
- Amounts owed
- Length of credit history
- New credit

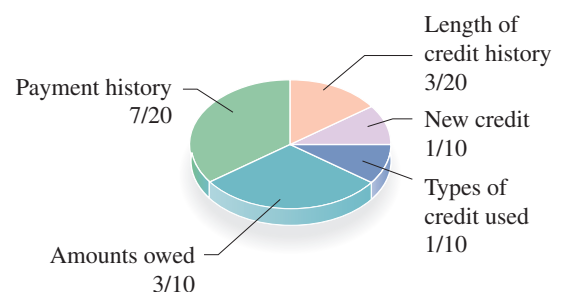

Using Your Knowledge

Many products (such as cereal, milk, etc.) list their nutrition information per serving. For example, Product 19 contains 3 grams of protein. If the recommended daily allowance (RDA) of protein is 70 grams, Product 19 provides $\frac{3}{70}$ of your daily protein needs. In the following problems find the fraction of the protein RDA (70 grams) provided by the given product. Then write your answer as a decimal, to two digits.

65. Special K, 4 grams per serving
 67. Spinach (1 cup), 5 grams
 69. 1 egg, 7 grams

66. Cornflakes, 2 grams per serving
 68. Froot Loops, 1 gram per serving

Bolting In The chart shows the drill bit size (column 2) to be used to tap a screw or bolt of a certain size (column 1). If you use the closest fractional size to a $\frac{3}{64}$ -inch bit (third row), the chart shows the decimal inches equivalency (column 4) is **.0469** (as you will discover, this is only an approximation).

(1)	(2)	(3)	(4)
To Tap This Size Screw or Bolt:	Use This Drill Bit:	(Closest Fractional:)	Decimal Inches
0-80 NF*	3/64"	3/64"	.0469
1-72 NF	#53	1/16"	.0595
3-48 NC*	#47	5/64"	.0785
4-48 NF	#42	3/32"	.0935

Source: <http://www.korit.com/tapndrill.htm>.

* NF means Natural fine thread; NC means National coarse thread.

Terminating	Repeating
$\frac{7}{8} = \frac{7}{2 \cdot 2 \cdot 2} = 0.875$	$\frac{1}{3} = \frac{1}{3} = 0.\bar{3}$
$\frac{3}{4} = \frac{3}{2 \cdot 2} = 0.75$	$\frac{2}{3} = \frac{2}{3} = 0.\bar{6}$
$\frac{5}{8} = \frac{5}{2 \cdot 2 \cdot 2} = 0.625$	$\frac{1}{6} = \frac{1}{2 \cdot 3} = 0.1\bar{6}$
$\frac{1}{2} = \frac{1}{2} = 0.5$	$\frac{1}{9} = \frac{1}{3 \cdot 3} = 0.\bar{1}$
$\frac{3}{8} = \frac{3}{2 \cdot 2 \cdot 2} = 0.375$	$\frac{1}{12} = \frac{1}{2 \cdot 2 \cdot 3} = 0.08\bar{3}$
$\frac{1}{5} = \frac{1}{5} = 0.2$	$\frac{1}{7} = \frac{1}{7} = 0.14285\bar{7}$
$\frac{1}{10} = \frac{1}{2 \cdot 5} = 0.1$	$\frac{1}{11} = \frac{1}{11} = 0.0\bar{9}$

70. Find the *exact* measurement for a $\frac{3}{64}$ -inch bit written as a decimal, then round your answer to four decimal places.
 71. Find the *exact* measurement for a $\frac{1}{16}$ -inch bit written as a decimal, then round your answer to four decimal places.
 72. Find the *exact* measurement for a $\frac{5}{64}$ -inch bit written as a decimal, then round your answer to four decimal places.
 73. Find the *exact* measurement for a $\frac{3}{32}$ -inch bit written as a decimal, then round your answer to four decimal places.

74. Here are some fractions and their decimal equivalents.

Look at the denominators of the terminating fractions. Now look at the denominators of the repeating fractions. Can you make a conjecture (guess) about the denominators of the fractions that terminate?

>>> Write On

75. Write in your own words the procedure you use to convert a fraction to a decimal.
 76. Write in your own words the procedure you use to convert a decimal to a fraction. Does the same procedure apply to terminating as well as repeating fractions? What is the difference?

>>> Concept Checker

Fill in the blank(s) with the correct word(s), phrase, or mathematical statement.

77. To convert a **fraction** to a **decimal**, divide the _____ by the _____.
 78. The first step in converting a terminating decimal to a fraction is to write the digits to the _____ of the decimal point as the _____ of the fraction.
 79. The first step in converting a **pure repeating decimal** to a **fraction** is to write the repeating part as the _____ of the fraction.
 80. When changing a **pure repeating decimal** to a **fraction** the _____ consists of as many _____ as there are digits in the _____.

nines
left
repetend
numerator
denominator
right

>>> Mastery Test

81. A bookstore sells \$4800 worth of mathematics books. If total sales are \$8000, what decimal part of sales are mathematics books?
82. What decimal part of 16 is 7?
83. Write as a reduced fraction:
 a. 0.41 b. 0.303
84. Write as a reduced fraction:
 a. 3.19 b. 2.15
85. Write as a reduced fraction:
 a. 0.035 b. 0.0375
86. Write $\frac{3}{7}$ as a decimal
87. Write as a decimal:
 a. $\frac{3}{5}$ b. $\frac{9}{40}$

>>> Skill Checker

Fill in the blank with $<$ or $>$ so that the resulting inequality is true.

88. $\frac{3}{10}$ _____ $\frac{4}{13}$

89. $\frac{3}{11}$ _____ $\frac{2}{7}$

90. $\frac{4}{9}$ _____ $\frac{3}{7}$

91. $\frac{5}{7}$ _____ $\frac{5}{6}$

3.4

Decimals, Fractions, and Order of Operations

▶ Objectives

You should be able to:

- A** > Compare two or more decimals and determine which is larger.
- B** > Compare fractions and decimals and determine which is larger.
- C** > Solve applications involving fractions, decimals, and the order of operations.

▶ To Succeed, Review How To . . .

1. Write a fraction as a decimal. (pp. 234–236)
2. Divide a decimal by a whole number. (p. 226)
3. Understand the meaning of and notation for pure repeating decimals. (p. 237)
4. Work with the order of operations. (pp. 83, 178)

▶ Getting Started

Which of the two Pepsi offers is better? To answer this question, we can find the price of each can by dividing \$2.00 by 8 and \$2.99 by 12 and then comparing the individual price of each can.

$$\begin{array}{r} 0.25 \\ 8 \overline{)2.00} \\ \underline{16} \\ 40 \\ \underline{40} \\ 0 \end{array} \qquad \begin{array}{r} 0.24 \\ 12 \overline{)2.99} \\ \underline{24} \\ 59 \\ \underline{48} \\ 11 \end{array}$$

Since $0.25 > 0.24$, 12 cans for \$2.99 is a better deal.

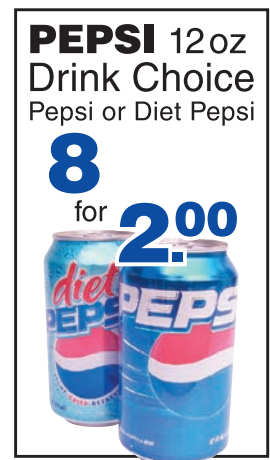

A > Comparing Decimals

What about comparing 0.251 and 0.25? We can do this by writing 0.25 as 0.250 and noting that $0.251 > 0.250$. We inserted a placeholder 0 at the end of 0.25 to make it 0.250 so that both decimals had three decimal digits. In general, to compare two decimals we use the following procedure:

TO COMPARE DECIMALS

Make sure all decimals have the same number of decimal digits (include extra placeholder 0's to the right of the decimal point if necessary). Compare corresponding digits starting at the left until two of the digits are different. The number with the larger digit is the larger of the decimals.

Thus, to compare 3.14, 3.15, and 3.1, we first write 3.1 as 3.10. We then write the three decimals as

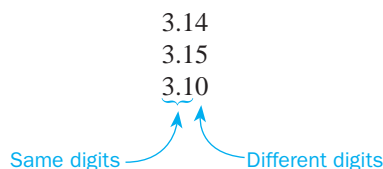

Since the 5 is the greatest digit in the hundredths place, 3.15 is the greatest decimal. Thus,

$$3.15 > 3.14 > 3.10$$

EXAMPLE 1 Comparing decimals

Arrange in order of decreasing magnitude (from largest to smallest): 5.013, 5.01, 5.004.

SOLUTION 1 First, write a 0 at the end of 5.01 so that all three numbers have three decimal digits. Then write:

5.013
5.010
5.004

Thus,

$$5.013 > 5.010 > 5.004$$

(Note that 5.013 and 5.010 both have a 1 in the hundredths place, so they are both larger than 5.004. Moreover, since 5.013 has a 3 in the thousandths place and 5.010 has a 0, 5.013 is greater.)

PROBLEM 1

Arrange in order of decreasing magnitude: 6.024, 6.02, and 6.002.

How can we compare $3.\overline{14}$, $3.\overline{14}$, and 3.14? Since the bar indicates the part that repeats,

$$3.\overline{14} = 3.141414 \dots$$

$$3.\overline{14} = 3.144444 \dots$$

$$3.14 = 3.140000 \quad (\text{Note added 0's})$$

The first three columns (starting at the left) have the same numbers, 3, 1, and 4, respectively. In the fourth (thousandths) column, the largest number is the 4 in $3.\overline{14}$. Thus, $3.\overline{14}$ is the greatest decimal, followed by $3.\overline{14}$ and 3.14; that is,

$$3.\overline{14} > 3.\overline{14} > 3.14$$

Answers to PROBLEMS

1. $6.024 > 6.02 > 6.002$

EXAMPLE 2 Comparing decimals

Write in order of decreasing magnitude: $3.14\overline{5}$, 3.145 , and $3.14\overline{5}$.

SOLUTION 2 We rewrite the numbers as:

$$3.14\overline{5} = 3.14555 \dots$$

$$3.145 = 3.14500$$

$$3.14\overline{5} = 3.14545 \dots$$

Starting from the left, the first four columns have the same numbers (3, 1, 4, and 5). In the fifth column, the greatest number is 5, followed by 4 and then by 0, corresponding to $3.14\overline{5}$, $3.14\overline{5}$, and 3.145 , respectively. Thus,

$$3.14\overline{5} > 3.14\overline{5} > 3.145$$

PROBLEM 2

Write in order of decreasing magnitude: $2.\overline{145}$, $2.14\overline{5}$, and 2.145 .

B > Comparing Fractions and Decimals

Are you watching your intake of fats? If you eat a McDonald's hamburger weighing 100 grams, 11 of these grams will be fat; that is, $\frac{11}{100}$ of the hamburger is fat. On the other hand, 0.11009 of a Burger King hamburger is fat. Which hamburger has more fat? To compare these numbers, we write $\frac{11}{100}$ as a decimal, adding three zeros so that we can compare the result with 0.11009. We write:

$$\frac{11}{100} = 0.11000$$

and

$$0.11009 = 0.11009$$

Thus, $0.11009 > 0.11000$; that is, the Burger King hamburger has proportionately more fat. Here is the rule:

TO COMPARE A DECIMAL AND A FRACTION

Write the fraction as a decimal and compare it with the given number.

EXAMPLE 3 Finding the water in the Coke

In a court case called *The U.S. v. Forty Barrels and Twenty Kegs of Coca-Cola*, the first analysis indicated that $\frac{3}{7}$ of the Coca-Cola was water. Another analysis showed that 0.41 of the Coca-Cola was water. Which of the two analyses indicated more water in the Coke?

SOLUTION 3 We must compare $\frac{3}{7}$ and 0.41. If we divide 3 by 7, we obtain

$$\begin{array}{r} 0.42 \\ 7 \overline{)3.00} \\ \underline{28} \\ 20 \\ \underline{14} \\ 6 \end{array} \quad \begin{array}{l} \text{(We stop here because the answer has two decimal places,} \\ \text{so we can compare 0.42 with 0.41.)} \end{array}$$

Since $\frac{3}{7} \approx 0.42 > 0.41$, the first analysis showed more water in the Coke.

PROBLEM 3

A chemical analysis indicated that $\frac{4}{7}$ of a substance was oil. A second analysis showed that 0.572 of the substance was oil. Which of the two analyses showed more oil?

EXAMPLE 4 Comparing land areas

The chart shows the fraction of the land area covered by each continent.

a. Africa covers approximately $\frac{1}{5}$ of the land area of Earth. Which is larger, $\frac{1}{5}$ or 0.203?

PROBLEM 4

- a. North America covers approximately $\frac{4}{25}$ of the land area of Earth. Which is larger, $\frac{4}{25}$ or 0.163?
- b. Europe covers about 0.067 of the land area of Earth. Which is smaller, 0.067 or $\frac{7}{100}$?

(continued)

Answers to PROBLEMS

2. $2.14\overline{5} > 2.\overline{145} > 2.145$ 3. The second analysis 4. a. 0.163 b. 0.067

- b. South America covers 0.124 of the land area of Earth. Which is smaller, 0.124 or $\frac{9}{100}$?

Continent	Total Land Area
The World	1.00
Asia (plus the Middle East)	0.30
Africa	0.203
North America	0.163
South America	0.124
Antarctica	$\frac{9}{100}$
Europe	$\frac{7}{100}$
Australia (plus Oceania)	$\frac{5}{100}$

Source: Enchanted Learning.com.

SOLUTION 4

- a. To compare $\frac{1}{5}$ and 0.203, we rewrite $\frac{1}{5}$ as a decimal. Dividing 1 by 5 we have:

$$\frac{1}{5} = 0.20$$

We then write
and

$$\frac{1}{5} = 0.200$$

$$0.203$$

The first two columns after the decimal (the 2 and the 0) are the same, but in the thousandths column, we have a 3 for the 0.203.

Thus, $0.203 > \frac{1}{5}$

This means that 0.203 is larger than $\frac{1}{5}$.

- b. We have to compare $\frac{9}{100}$ and 0.124. Writing $\frac{9}{100}$ as a decimal, we obtain:

and

$$\frac{9}{100} = 0.090$$

$$0.124 \quad \text{Already a decimal}$$

Thus, $0.124 > \frac{9}{100}$
which means that 0.124 is larger than $\frac{9}{100}$.

GREEN MATH

EXAMPLE 5 Windows and insulation

The return on investment ($\text{ROI} = \frac{\text{savings}}{\text{added cost}}$) when you install Energy Star windows is 0.43. (See Example 8, Section 3.3.) If you insulate your basement walls, your added cost is \$750 and your annual electricity savings are \$300.

- What is your ROI written as a reduced fraction?
- Compare 0.43 and the ROI from part a.
- Which is the better ROI, new windows or insulating the basement walls?

SOLUTION 5

- $\frac{300}{750} = \frac{2}{5}$
- We have to compare 0.43 and $\frac{2}{5}$. Convert $\frac{2}{5}$ to a decimal by dividing 2 by 5, obtaining 0.40. Now it is easy to compare $\frac{2}{5} = 0.40$ and 0.43; 0.43 is larger.
- The ROI when you install new windows (0.43) is better than insulating your basement walls (0.40).

PROBLEM 5

If you increase the insulation of your heating/AC ducts, the savings are \$180 at a cost of \$450.

- What is the ROI written as a reduced fraction?
- Compare the ROI of insulating your heating/AC ducts with the insulation of your basement walls (0.40).
- Which is the better ROI, insulating your heating/AC ducts or insulating your basement walls?

Answers to PROBLEMS

5. a. $\frac{2}{5}$ b. $\frac{2}{5}$ and 0.40 are the same c. Neither, they are both the same, 0.40

Obesity, Cancer Linked

Obesity may be linked to one in six cancer deaths, a new study says. The study used body mass index, which measures weight against height. A BMI of 18.5 to 24.9 was considered normal, and a BMI of 30 or above was considered obese.

Percent increase in death rates from all cancers based on body mass index score

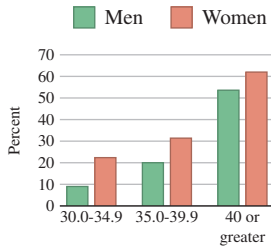

Body mass index (BMI) is equal to:

$$\frac{\text{Weight (pounds)}}{\text{Height (inches)}^2} \times 703$$

Source: Tampa Tribune, 4/24/03.

C > Applications and Order of Operations

As you can see from the chart to the left, there is a relationship between obesity (being overweight) and cancer. How do we measure obesity? By using the body mass index (BMI) as defined in the margin. A BMI of 18.5 to 24.9 is normal, but if the BMI is over 30 the person is considered obese. Now, suppose a person is 74 inches tall and weighs 148 pounds. Is the person obese?

According to the formula,

$$\text{BMI} = \frac{\text{weight}}{\text{height}^2} \times 703 = \frac{148}{74^2} \times 703 = \frac{2 \cdot 74}{74 \cdot 74} \times 19 \cdot 37 = 19$$

Since 19 is between 18.5 and 24.9 the person is normal.

Note that in this case 74 was a factor of 148 in the numerator and $2 \times 37 = 74$, so the computation was simple. For more complicated calculations of the form $\frac{a}{b} \times n$ you can use one of these two methods:

Method 1. Convert $\frac{a}{b}$ to a decimal and multiply by n .

Method 2. Write n as $\frac{n}{1}$ and multiply by $\frac{a}{b}$.

Of course, you should do the calculations using the order of operations for decimals, which, fortunately, are the same rules as those used for fractions. Here they are for your convenience:

ORDER OF OPERATIONS (PEMDAS)

1. Do all calculations inside *Parentheses* and other grouping symbols (), [], { } and the division bar first.
2. Evaluate all *Exponential* expressions.
3. Do *Multiplications* and *Divisions* in order from left to right.
4. Do *Additions* and *Subtractions* in order from left to right.

Remember that in steps 3 and 4, operations are done as they occur (in order from left to right). Thus, if in step 3, a multiplication occurs **before** a division, multiply first! If a division occurs **before** a multiplication, divide first!

Let us use all these concepts in Example 6.

EXAMPLE 6 Finding BMI (body mass index)

Find the BMI (to the nearest whole number) for a man 70 inches tall and weighing 250 pounds.

SOLUTION 6

$$\text{BMI} = \frac{\text{weight}}{\text{height}^2} \times 703 = \frac{250}{70^2} \times 703 = \frac{250}{70 \cdot 70} \times 703$$

First, divide numerator and denominator of $\frac{250}{70 \cdot 70}$ by 10 to obtain $\frac{25}{70 \cdot 7}$. Then it is probably easier to use Method 2, multiply 25 by 703 and divide the product, 17,575, by 490. We obtain

$$\begin{array}{r} 35.8 \\ 490 \overline{)17575.0} \\ \underline{1470} \\ 2875 \\ \underline{2450} \\ 4250 \\ \underline{3920} \\ 330 \end{array}$$

To the nearest whole number 35.8 is 36. Thus, the BMI is about 36. Note that according to the graph, a BMI of 35–39.9 for a man indicates a 20 percent increase in death rates for all cancers.

PROBLEM 6

Find the BMI (to the nearest whole number) for a woman 60 inches tall and weighing 180 pounds.

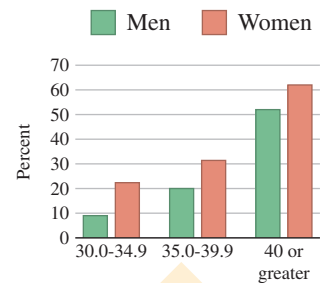

A 36 BMI for a man indicates a 20% increase in death rates from all cancers.

Answers to PROBLEMS

6. 35

Now, a reminder: if there are several operations involved, follow the order of operations given on page 247. Let us see how.

EXAMPLE 7 Order of operations involving fractions

Simplify $(\frac{1}{2})^3 \div \frac{1}{4} \cdot \frac{1}{2} + \frac{1}{3}(\frac{5}{2} - \frac{1}{2})$.

SOLUTION 7

$$(\frac{1}{2})^3 \div \frac{1}{4} \cdot \frac{1}{2} + \frac{1}{3}(\frac{5}{2} - \frac{1}{2})$$

$$= (\frac{1}{2})^3 \div \frac{1}{4} \cdot \frac{1}{2} + \frac{1}{3}(2)$$

$$= \frac{1}{8} \div \frac{1}{4} \cdot \frac{1}{2} + \frac{1}{3}(2)$$

$$= \frac{1}{2} \cdot \frac{1}{2} + \frac{1}{3}(2)$$

$$= \frac{1}{4} + \frac{2}{3}$$

$$= \frac{11}{12}$$

Do operations inside parentheses: $(\frac{5}{2} - \frac{1}{2}) = (\frac{4}{2}) = (2)$

Do exponents: $(\frac{1}{2})^3 = \frac{1}{8}$

Do division: $\frac{1}{8} \div \frac{1}{4} = \frac{1}{8} \cdot \frac{4}{1} = \frac{1}{2}$

Do multiplication: $\frac{1}{2} \cdot \frac{1}{2} = \frac{1}{4}$; $\frac{1}{3}(2) = \frac{2}{3}$

Do addition: $\frac{1}{4} + \frac{2}{3} = \frac{3}{12} + \frac{8}{12} = \frac{11}{12}$

PROBLEM 7

Simplify $(\frac{1}{2})^3 \div \frac{1}{4} \cdot \frac{1}{2} + \frac{1}{3}(\frac{5}{2} - \frac{3}{2})$.

We will practice more with the order of operations in Problems 31–52.



Calculator Corner

As we mentioned in the Calculator Corner for Section 3.3, you can convert a fraction to a decimal by dividing the numerator by the denominator. Then you can compare the resulting decimal to a given fraction. Thus, in Example 3, the fraction $\frac{3}{7}$ can be converted to a decimal by pressing **3** **÷** **7** **ENTER**. The calculator will give the answer 0.428571428, which you can immediately compare with 0.41.

> Exercises 3.4



> Practice Problems > Self-Tests
> Media-rich eBooks > e-Professors > Videos

< **A** > **Comparing Decimals** In Problems 1–16, arrange in order of decreasing magnitude using the > sign.

- | | | |
|---|---|---|
| 1. 66.066, 66.06, and 66.606 | 2. 0.301, 0.311, and 0.31 | 3. 0.501, 0.51, and 0.5101 |
| 4. 0.60, 0.6007, and 0.607 | 5. 9.099, 9.909, and 9.999 | 6. 2.8031, 2.8301, and 2.8013 |
| 7. 7.043, 7.403, and 7.430 | 8. 3.351, 3.35, and 3.6 | 9. $3.\overline{14}$, $3.\overline{14}$, and 3.14 |
| 10. 2.87, $2.\overline{87}$, and $2.8\overline{7}$ | 11. 5.1, $5.\overline{1}$, and 5.12 | 12. 8.9, $8.\overline{9}$, and 8.99 |
| 13. 0.333, $0.\overline{3}$, and 0.33 | 14. $0.\overline{99}$, 0.999, and 0.99 | 15. 0.88, $0.\overline{8}$, and $0.\overline{81}$ |
| 16. $3.\overline{7}$, 3.77, and $3.\overline{78}$ | | |

Answers to PROBLEMS

7. $\frac{7}{12}$

< B > Comparing Fractions and Decimals In Problems 17–26, determine which is greater.

17. $\frac{1}{9}$ or 0.111 18. 0.23 or $\frac{2}{9}$ 19. 0.1666 or $\frac{1}{6}$ 20. 0.83 or $\frac{5}{6}$ 21. 0.285 or $\frac{2}{7}$
 22. 0.43 or $\frac{3}{7}$ 23. $0.1\bar{4}$ or $\frac{1}{7}$ 24. $\frac{3}{7}$ or $0.4\bar{2}$ 25. $0.\bar{9}$ or $\frac{1}{11}$ 26. $\frac{1}{13}$ or $0.0\bar{7}$

>>> Applications: Green Math

The graph shows the energy usage for an average home with four members.

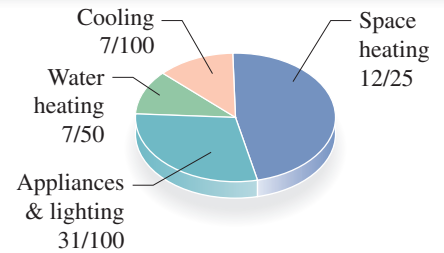

27. a. Convert all the fractions to decimals.
 b. Which categories use the most and least energy?
28. a. Arrange the fractions obtained in Problem 27 in order of decreasing magnitude (largest to smallest).
 b. Arrange the corresponding fractions in order of decreasing magnitude (largest to smallest). Which is easier: arranging the fractions or arranging the decimals?

< C > Applications and Order of Operations

29. *Finding BMI* Find the BMI (to the nearest whole number) of a person 59 inches tall and weighing 150 pounds. (*Hint*: $BMI = \frac{\text{weight}}{\text{height}^2} \times 703$.)
30. *Finding BMI* Find the BMI (to the nearest whole number) of a person 61 inches tall and weighing 100 pounds.

In Problems 31–52, use the order of operations.

31. $\frac{3}{4} \cdot 16.64$ 32. $\frac{3}{5} \cdot 218.14$ 33. $2\frac{3}{5} \cdot 4.65$ 34. $1\frac{3}{4} \cdot 120.8$
 35. $\frac{10}{9} \cdot 8.25$ 36. $\frac{11}{6} \cdot 8.12$ 37. $4\frac{3}{4} - 1.75$ 38. $40\frac{3}{5} - 18.42$
 39. $\frac{2}{7} \cdot 0.2135 + \frac{7}{4} \cdot 0.248$ 40. $\frac{4}{5} \cdot 685.1 - \frac{5}{8} \cdot 98.08$ 41. $\frac{3}{4} \cdot 0.92 - 0.96 \cdot \frac{3}{8}$ 42. $\frac{2}{3} \cdot 0.81 - 0.48 \cdot \frac{5}{8}$
 43. $\frac{4}{3} \cdot 128.1 - 31.5 \div \frac{7}{5}$ 44. $\frac{5}{6} \cdot 0.2136 - 0.105 \div \frac{3}{5}$ 45. $14.05 \div \frac{5}{8} + \frac{2}{5} \cdot 15.5$
 46. $28.07 \div \frac{7}{3} + \frac{5}{6} \cdot 24.06$ 47. $12 \div 6 - \left(\frac{1}{3} + \frac{1}{2}\right)$ 48. $18 \div 9 - \left(\frac{1}{4} + \frac{1}{6}\right)$
 49. $\frac{1}{3} \cdot \frac{1}{4} \div \frac{1}{2} + \left(\frac{5}{6} - \frac{1}{2}\right)$ 50. $\frac{1}{3} \cdot \frac{1}{6} \div \frac{1}{2} + \left(\frac{4}{5} - \frac{1}{2}\right)$ 51. $\frac{1}{6} \div \frac{1}{3} \cdot \frac{1}{3} \cdot \frac{1}{3} + \left(\frac{1}{4} - \frac{1}{9}\right)$
 52. $\frac{1}{10} \div \frac{1}{2} \cdot \frac{1}{2} \cdot \frac{1}{2} + \left(\frac{2}{3} - \frac{1}{2}\right)$

>>> Using Your Knowledge

Decimals are used to measure several physical properties, such as weight and heat.

53. *Weight of metals* Here are the weights of several metals in pounds per cubic inch. Arrange them from *heaviest* to *lightest*.
- | | |
|---------|--------|
| Brass | 0.3103 |
| Cadmium | 0.3121 |
| Copper | 0.3195 |
| Nickel | 0.3175 |

54. *Specific heat* The **specific heat** of a substance is the amount of heat required to raise the temperature of 1 gram of the substance 1°C. Here are the specific heats of several substances. Arrange the substances from *least* to *greatest* in terms of specific heat. (The lower the specific heat, the less heat is needed to raise the temperature of the substance a given amount.)

Boron	0.309
Sugar	0.30
Wood	0.33

>>> Write On

55. Two common approximations for the number π are $\frac{22}{7}$ and 3.141593. How would you determine which of these two approximations is greater?
56. Fill in the blank with $>$ or $<$ to make the resulting statement true:
- a. 3.141592 _____ π
- b. 3.141593 _____ π
- Write in your own words the reasons for your answers.

>>> Concept Checker

Fill in the blank(s) with the correct word(s), phrase, or mathematical statement.

57. To compare a decimal and a fraction, write the fraction as a _____ and compare it with the given number.
58. When using the order of operations with decimals, we first do all calculations inside _____.
59. The **E** in **PEMDAS** means that we do all _____ expressions.
60. When using the order of operations, we must do them as they occur from _____ to _____.

right **decimal**
left **parentheses**
exponential
powers

>>> Mastery Test

61. Find the BMI (to the nearest whole number) for a person 70 inches tall and weighing 230 pounds.
Hint: $BMI = \frac{\text{weight}}{\text{height}^2} \times 703$
62. An encyclopedia claims that $\frac{7}{10}$ of the surface of the earth is covered by oceans. Another encyclopedia says that 0.71 of the earth is covered by oceans. Which is greater, $\frac{7}{10}$ or 0.71?
63. Three-sevenths of the students in class A are women. The fraction of women in class B is 0.4. Which class has more women?
64. Write in order of *increasing* magnitude (smallest to largest):
 7.14 $\overline{6}$ 7.146 7.14 $\overline{6}$
65. Write in order of *decreasing* magnitude (largest to smallest):
 8.015 8.01 8.005

>>> Skill Checker

Find:

66. $3.4 \cdot 8.12$ 67. $4.5 \cdot 6.31$ 68. $0.6 \div 0.03$
69. $3.5 \div 0.07$ 70. $3.8 + 3.2 \cdot 4 \div 2$ 71. $3.1(4.5 - 0.5) + 3.2 \div 2 \cdot 4$

3.5

Equations and Problem Solving

▶ Objectives

You should be able to:

A > Solve equations involving decimals.

B > Solve word problems involving decimals.

▶ To Succeed, Review How To . . .

1. Use the principles and rules used to solve equations. (pp. 92–94)
2. Use the RSTUV method to solve word problems. (pp. 95, 186)
3. Add, subtract, multiply, and divide decimals. (pp. 212–214, 214–217, 222–223, 224–226)

▶ Getting Started

Gas range has	Low as
170° valve rotation	\$654.99
for more precise	white
flame setting	\$19 MONTHLY

**CUT
\$100**

The ad says that \$100 is cut from the price if you buy the gas range for \$654.99. How much did it cost before? \$100 *more*—that is, \$754.99. If we let c be the old cost, we know that:

The old cost was cut by \$100 to \$654.99:

$$c - 100 = 654.99$$

$$c - 100 + 100 = 654.99 + 100 \quad \text{Add 100 to both sides.}$$

$$c = 754.99$$

We have illustrated the fact that you can add a number like 100 to both sides of an equation and obtain an equivalent equation.

Equations such as $c - 100 = 654.99$ can be solved using the idea of an equivalent equation. We restate the principles involved here for your convenience.

**A** > Solving Equations Involving Decimals**PRINCIPLES FOR SOLVING EQUATIONS**

The equation $a = b$ is *equivalent* to:

$$a + c = b + c \quad \text{Addition principle}$$

$$a - c = b - c \quad \text{Subtraction principle}$$

$$a \cdot c = b \cdot c \quad \text{Multiplication principle} \\ (c \neq 0)$$

$$a \div c = b \div c \quad \text{Division principle } (c \neq 0)$$

$$\text{or } \frac{a}{c} = \frac{b}{c} \quad (c \neq 0)$$

In effect, these principles tell us that to solve an equation, we may add or subtract the same number c on both sides and multiply or divide both sides by the same nonzero number c .

EXAMPLE 1 Solve by subtracting a numberSolve: $x + 7.2 = 9.5$.**SOLUTION 1** Since we wish to have x by itself on the left side (it now has 7.2 added to it), we *subtract* 7.2 from both sides. Here is the procedure:

$$\begin{aligned} x + 7.2 &= 9.5 && \text{Given.} \\ x + 7.2 - 7.2 &= 9.5 - 7.2 && \text{Subtract 7.2 from both sides.} \\ x &= 9.5 - 7.2 && \text{Subtract 7.2 from 9.5.} \\ &= 2.3 \end{aligned}$$

PROBLEM 1Solve $y + 6.4 = 9.8$.**EXAMPLE 2** Solve by adding a numberSolve: $y - 8.2 = 3.9$.**SOLUTION 2** This time we *add* 8.2 to both sides like this:

$$\begin{aligned} y - 8.2 &= 3.9 && \text{Given.} \\ y - 8.2 + 8.2 &= 3.9 + 8.2 && \text{Add 8.2 to both sides.} \\ y &= 3.9 + 8.2 && \text{Add 3.9 and 8.2.} \\ &= 12.1 \end{aligned}$$

PROBLEM 2Solve $x - 5.4 = 6.7$.**EXAMPLE 3** Solve by dividing by a numberSolve: $3.6 = 0.6z$.**SOLUTION 3** Since z is being *multiplied* by 0.6, we must *divide* both sides by 0.6. We have:

$$\begin{aligned} 3.6 &= 0.6z && \text{Given.} \\ 3.6 \div 0.6 &= 0.6z \div 0.6 && \text{Divide both sides by 0.6.} \\ 3.6 \div 0.6 &= z && \text{Divide 3.6 by 0.6.} \\ 6 &= z \end{aligned}$$

$$\begin{array}{r} 6 \\ 0.6 \overline{)3.6} \\ \underline{3.6} \\ 0 \end{array}$$

Thus, the solution is $6 = z$, or $z = 6$.**PROBLEM 3**Solve $6.3 = 0.9z$.**EXAMPLE 4** Solve by multiplying by a numberSolve: $6 = \frac{m}{3.2}$.**SOLUTION 4** To have the m by itself on the right, we must multiply both sides by 3.2. Here is the procedure:

$$\begin{aligned} 6 &= \frac{m}{3.2} && \text{Given.} \\ 3.2 \cdot 6 &= \frac{m}{3.2} \cdot 3.2 && \text{Multiply both sides by 3.2.} \\ 3.2 \cdot 6 &= m && \text{Multiply 3.2 by 6.} \\ 19.2 &= m \end{aligned}$$

PROBLEM 4Solve $5 = \frac{n}{2.4}$.**B > Solving Word Problems Involving Decimals**

Do you know what a carbon footprint is? It is the total amount of greenhouse gas (GHG) emissions you have produced. A carbon footprint calculator can help you find your carbon footprint, you can even do something about it by picking from the suggestions at: <http://www.kiplinger.com/features/archives/2007/07/gogreen.html>.

Answers to PROBLEMS

1. $y = 3.4$ 2. $x = 12.1$
 3. $z = 7$ 4. $n = 12$

GREEN MATH

EXAMPLE 5 Offsetting carbon emissions

It costs \$5.50 per ton of CO₂ to offset the amount of emissions you have created. If you pay \$44 to offset your carbon emissions, how many tons T have you created?

SOLUTION 5

The cost to offset the amount of emissions is $5.50T$, where T is the number of tons of CO₂ you have created. Since you have paid \$44

$$\begin{aligned} 5.50T &= 44 \\ T &= \frac{44}{5.50} \quad \text{Divide both sides by 5.50} \\ T &= 8 \end{aligned}$$

Thus,

This means you have created 8 tons, or 16,000 pounds of CO₂. You can verify that 8 is the correct answer by multiplying 8×5.50 and obtaining the \$44 paid. Just remember that every gallon of gas you burn produces 20 pounds of CO₂!

Read more about carbon offsetting at <http://www.carbonfund.org/>.

PROBLEM 5

A couple paid \$176 to offset their CO₂ emissions. If the cost is \$8 per ton, how many tons did they pay for?

EXAMPLE 6 Travel distances

You enter I-75 at mile marker 4 (Miami Gardens Dr.) traveling north. What is the mile marker number after you travel the specified number of miles? To solve this problem, we shall use the RSTUV method we studied in Sections 1.9 and 2.8.

- 30 miles
- 120 miles
- d miles
- If you have a flat tire at marker 256.8, how many miles m have you traveled?



SOLUTION 6

- Read the problem.** Read the problem very carefully. There are several things you should know: Miles are marked consecutively and in ascending order as you travel north, that is, if you start at marker 4, the next marker is 5, then 6, and so on.
- Select the unknown.** The unknown is the mile marker number.
- Translate the problem into an equation or inequality.**
 - If you start at marker 4 and go 30 miles, you are at marker $4 + 30 = 34$.
 - If you start at marker 4 and go 120 miles, you are at marker $4 + 120 = 124$.
 - If you start at marker 4 and go d miles, you are at marker $4 + d$. (See the pattern?)
 - If you start at marker 4 and travel m miles, you are at marker $4 + m$, which is given as marker 256.8.

PROBLEM 6

Find the marker number if you enter I-75 at mile marker 111 (Immokalee R.) and travel north for the specified number of miles.

- 50 miles
- 75 miles
- m miles
- If you have a flat tire at mile marker 263.4, how many miles m have you traveled?

(continued)

Answers to PROBLEMS

5. 22 6. a. 161 b. 186
c. $111 + m$ d. 152.4

4. Use the rules we have studied to solve the equation.

$$\begin{aligned} \text{Thus,} \quad 4 + m &= 256.8 \\ 4 + m - 4 &= 256.8 - 4 && \text{Subtract 4.} \\ m &= 252.8 \end{aligned}$$

So you have traveled 252.8 miles.

5. Verify the answer. The verification is left for you.

Sometimes you must use several of the principles to solve equations, as illustrated next.

EXAMPLE 7 Calculating bills

A customer received a cell phone bill for \$85.40 (before taxes and other charges). How many extra minutes did the customer use?

Plan Choices	Monthly Access	Monthly Airtime Allowance (in minutes)	Per Minute Rate After Allowance
America's Choice sm 300	\$35	300	\$0.45

SOLUTION 7

1. Read the problem. Read the problem carefully. Note that the bill is for \$85.40 and consists of two parts: the \$35 monthly access *plus* extra minutes after the 300-minute allowance. The minutes cost \$0.45 each.

2. Select the unknown. Let m be the number of extra minutes. Since they cost \$0.45 each, the cost for the m extra minutes is $0.45 \cdot m$.

3. Translate the problem into an equation or inequality. As we mentioned in step 1, the bill consists of

The monthly access *plus* the cost of the extra minutes

$$\$35 \quad + \quad 0.45 \cdot m$$

Since the bill is for \$85.40, we have the equation

$$\$35 + 0.45 \cdot m = \$85.40$$

4. Use the rules we have studied to solve the equation.

$$35 + 0.45 \cdot m - 35 = 85.40 - 35 \quad \text{Subtract 35.}$$

$$0.45m = 50.40$$

$$m = \frac{50.40}{0.45} \quad \text{Divide by 0.45.}$$

$$m = \frac{5040}{45} \quad \text{Multiply numerator and denominator by 100.}$$

$$m = 112$$

Thus, the number of extra minutes used is 112.

5. Verify the answer. The total bill is \$35 plus $0.45 \cdot 112$.

$$= \$35 + \$50.40 \text{ or } \$85.40$$

PROBLEM 7

If the bill is for \$62.90, how many extra minutes did the customer use?

TRANSLATE THIS

1. The average cost for tuition and fees at a 2-year public college is \$2191. This represents a 5.4% increase from last year's cost L .

Source: www.CollegeBoard.com.

2. The average 2-year public college student receives grant aid (G) that reduces the average tuition and fees of \$2191 to a net price of \$400.

Source: www.CollegeBoard.com.

3. According to the Census Bureau a person with a bachelor's degree earns 62% more on average than those with only a high school diploma. If a person with a high school diploma makes h dollars a year, what is the pay b for a person with a bachelor's degree?

Source: www.CollegeBoard.com.

4. At 2-year public institutions, the average tuition and fees is \$2191, which is \$112 more than last year's cost L . What was the cost of tuition and fees last year?

Source: www.CollegeBoard.com.

5. At American University, the cost per credit for undergraduate courses is \$918. What is the cost C for an undergraduate taking h credits?

Source: American University.

The third step in the RSTUV procedure is to **TRANSLATE the information into an equation. In Problems 1–10 TRANSLATE the sentence and match the correct translation with one of the equations A–O.**

- A. $T + 3.8 = 103.8$
 B. $2191 - G = 400$
 C. $P = 39 + 0.45m$
 D. $D = 10.9391P$
 E. $2191 = L + 5.4\%L$
 F. $b = h + 62\%h$
 G. $C = 13.75h$
 H. $C = 918h$
 I. $G - 2191 = 400$
 J. $h = b + 62\%h$
 K. $C = 51W$
 L. $P = 10.9391D$
 M. $W = 51C$
 N. $2191 = L + 112$
 O. $D = 10.9391P$

6. The monthly access fee for a cell phone plan is \$39 plus \$0.45 for each minute after a 300-minute allowance. If Joey used m minutes over 300, write an equation for the amount P Joey paid.
7. If the body temperature T of a penguin were 3.8°F warmer, it would be as warm as a goat, 103.8°F .
8. The Urban Mobility Institute reports that commuters say they would be willing to pay \$13.75 an hour to avoid traffic congestion. What would be the cost C for h hours of avoiding traffic congestion?
9. Since the price of gas is higher, commuters are willing to pay more than \$13.75 an hour to avoid traffic congestion, say W dollars per hour. South Florida travelers lose 51 hours per year due to traffic congestion. Write an equation that will give the total cost C for Florida travelers to avoid losing any time to traffic congestion.
10. As of this writing, one U.S. dollar is worth 10.9391 Mexican pesos. Write the formula to convert D dollars to P Mexican pesos.

Exercises 3.5

> Practice Problems > Self-Tests
 > Media-rich eBooks > e-Professors > Videos

< **A** > **Solving Equations Involving Decimals** In Problems 1–16, solve the equation.

- | | | |
|-------------------------|-------------------------|-------------------------|
| 1. $x + 8.2 = 9.7$ | 2. $x + 7.3 = 9.8$ | 3. $y + 3.6 = 10.1$ |
| 4. $y + 4.5 = 10.2$ | 5. $z - 3.5 = 2.1$ | 6. $y - 4.9 = 11.3$ |
| 7. $z - 6.4 = 10.1$ | 8. $z - 3.7 = 12.3$ | 9. $4.2 = 0.7m$ |
| 10. $5.6 = 0.8m$ | 11. $0.63 = 0.9m$ | 12. $0.72 = 0.9m$ |
| 13. $7 = \frac{n}{3.4}$ | 14. $4 = \frac{n}{3.6}$ | 15. $3.1 = \frac{n}{4}$ |
| 16. $4.5 = \frac{n}{3}$ | | |

>>> Applications: Green Math

17. One of the problem-solving suggestions given on page 95 is to *work backward*. Let us practice that technique by trying to reverse the three steps below assuming that **you drive 12,000 miles a year in a car that yields 20 miles per gallon.**
1. You use $\frac{12,000 \text{ miles}}{20 \text{ miles/gallon}} = 600$ gallons of gas.
 2. Each gallon of gas used produces **20** pounds of CO_2 . You produced $600 \times 20 = 12,000$ pounds of CO_2 that is $\frac{12,000}{2000} = 6$ tons of it!
 3. To offset those 6 tons of CO_2 , at \$5.50 per ton, you pay \$33.00.

Suppose you pay \$41.25 to offset the carbon emissions. **Reverse steps** 1, 2, and 3 to find out how many miles you drove. Start by solving $5.50T = \$41.25$ to find how many tons of CO_2 you produced.

18. If you are driving the car of Exercise 17 and you pay \$55 to offset the CO_2 carbon emissions, how many miles did you drive the car?

< B > Solving Word Problems Involving Decimals In Problems 19–44, use the RSTUV method to solve.

19. *Temperature of polar bears* If the body temperature of a polar bear were 4.7°F warmer, it would be as warm as a goat, 103.8°F . What is the body temperature of a polar bear?
20. *Temperature of arctic gulls* If the body temperature of an arctic gull were increased by 5.9°C , it would be as warm as a goat, 39.9°C . What is the body temperature of the arctic gull?
21. *Garbage* The average American produces 1.94 pounds more garbage per day now than in 1960. If 2.68 pounds of garbage were produced by each person per day in 1960, how many pounds of garbage are produced per day by each person now?
22. *Eating vegetables* The average American eats 59.6 more pounds of vegetables than fruits a year. If the average American consumes 192.1 pounds of vegetables, what is the corresponding consumption of fruit?
23. *Losing billions* In January 1980 the Hunt brothers had \$4.5 billion in silver bullion. By March the price had fallen by \$4 billion. How much was their silver worth in March? (Bunker Hunt's only comment to their staggering loss was "A billion isn't what it used to be.")
24. *Business failures in the UK* The number of business failures this year in the UK is predicted to increase by 5100 to 25,000 next year. How many business failures were there in the UK this year?
25. *Decreasing Latin America exports* In a period of seven years, U.S. exports to Latin America decreased by \$8.061 billion to \$27.969 billion. How many billions were exported to Latin America before?
26. *Composite ACT scores* Between 1998 and 2001 the composite score on the ACT decreased by 0.2 points to 20.8. What was the composite score on the ACT in 1998?
27. *Social Security deductions* To find the Social Security deduction from your wages, multiply your wages by 0.0751. If the Social Security deduction on a check amounted to \$22.53, what was the amount of the wages?
28. *FUTA tax* To find the Federal Unemployment Tax (FUTA) deduction for an employer, multiply the total of the salaries paid by the employer by 0.062. If the FUTA tax totaled \$145.08, how much was the total of the salaries?
29. *Mileage deductions* The Internal Revenue Service allows a \$0.55 deduction for each mile driven for business purposes. If a person claimed a \$562.65 deduction, how many miles had the person driven?
30. *Health insurance* The first step in figuring the health insurance deduction for self-employed individuals is to multiply the annual amount of health insurance premiums by 0.70. If this product is \$3348.20, what was the total cost of health insurance premiums to the nearest dollar?
31. *Converting dollars to Euros* As of this writing, one Euro (the official currency of 12 European countries) was worth \$1.55 (dollars). To convert dollars to Euros, use the formula $E = \frac{D}{1.55}$. If you are in England and have \$50, how many Euros do you have?
32. *Paying for dinner in Greece* Next, you travel to Greece and your dinner costs \$186 (dollars before tax). How many Euros is that?
33. *Wine by the liter in France* You buy a 2-liter bottle of wine in France. If one quart is 0.95 liters, use the formula $Q = 0.95L$ to find how many quarts of wine you have. Answer to one decimal place.
34. *Buying oil by the liter* You buy 5 liters of oil for your car. How many quarts is that? Answer to one decimal place.
35. *Operating costs and mileage traveled* It is estimated that the operating costs (gas, oil, maintenance, and tires) for a standard six-cylinder automobile are 10.8 cents per mile, that is, \$0.108. If the cost amounts to \$885.60, how many miles were traveled?
36. *Total cost of operating a car and miles traveled* It is estimated that the total cost of operating an automobile is about \$0.45 per mile. If the cost of operating an automobile amounts to \$6840, how many miles were traveled?

- 37. Renting a truck in Canada** Discount Auto of Canada rents a pickup truck for \$39.99 per day plus \$0.12 per kilometer. If your bill for a one-day rental comes to \$60.63 (in dollars, before taxes), how many kilometers did you drive?
- 39. Partial payment for total cost at a public university** Annual tuition and fees at a public university are 0.30 of the total annual cost C . Your \$9000 partial payment consists of a \$6000 loan plus the $0.30C$. How much is the total annual cost C ?
- 41. Movie trivia** Quick, which movie do you think has brought in the most money (to the nearest million) at the box office?
- If you guessed *Avatar*, you are right! What about this: If you add the domestic gross income of this top movie (T) and the domestic gross of *Star Wars* (S), you will get \$1062 million. Translate this statement into an equation.
 - If the top-grossing movie T made \$140 million more than *Star Wars* (S), translate this statement into an equation.
 - Star Wars* actually grossed \$461 million. Find the gross for the top movie T . OK, the T is for *Titanic*.
- 43. Music** The worldwide sales of the two best-selling albums of all time reach \$92 million. If one album sells T millions and the other B millions,
- Translate this statement into an equation.
 - T sold \$10 million more than B . Translate this into an equation.
 - Substitute the equation you obtained in part **b** into the equation in part **a**, and solve for B . The albums are *Thriller* and *Back in Black*.
- Source: Wikipedia Disclaimer: The world's best-selling album cannot be listed officially, since there is no international body to count global record sales.
- 38. Renting a car from the university** The University of Minnesota Fleet Services will rent a full-size sedan for \$40 a day plus \$0.15 per mile. If the charges for one day amount to \$74.20 (before taxes and other charges), how many miles did you drive?
- 40. Partial payment for total cost at a private university** Board charges at a private university are 0.10 of the total annual cost C . Your \$17,100 partial payment consists of a \$15,200 scholarship plus the $0.10C$. How much is the total annual cost C ?
- 42. Movie Trivia** The top-grossing movie T mentioned in Problem 41 is not the best-ranking movie (defined as the movie that ranked number 1 the most weekends). The number of weekend rankings at number 1 for the best-ranking movie (B) is one more than the number 1 weekend rankings T for *Titanic*.
- Translate this statement into an equation.
 - If *Titanic* came in number 1 for 15 weekends, find B . By the way, the movie is *E.T.* *Avatar* came in first for 7 weekends.
- 44. Music** The Recording Industry Association of America says that the total number of copies of the two best-selling albums of all time reached 54 million. If one album sold E million copies and the other T million copies:
- Translate this statement into an equation.
 - E sold 2 million more copies than T . Translate this into an equation.
 - Substitute the equation you obtained in part **b** into the equation in part **a** and solve for T . The albums are *Thriller* and the *Eagles Greatest Hits*.
- Source: <http://www.infoplease.com/ipea/A0151020.html>.

Using Your Knowledge

The distance D (in miles) traveled in time T (in hours) by an object moving at a rate R (in miles per hour) is given by $D = R \cdot T$.

- 45.** A car travels 137.5 miles in 2.5 hours. How fast was it traveling?
- 46.** A car travels 227.5 miles in 3.5 hours. How fast was it traveling?
- 47.** In 2003, Gil de Ferran won the Indianapolis 500 by posting a speed of about 156 miles per hour. How many hours did it take to cover the 500 miles? (Give the answer to the nearest tenth of an hour.)
- 48.** In 2003 Mark Martin won the Coca-Cola 600 by posting a speed of about 138 miles per hour. How many hours did it take to cover the 600 miles? (Give the answer to three decimal digits.)

Write On

- 49.** Write in your own words the procedure you use to solve word problems.
- 50.** Write in your own words how you decide what the unknown is in a word problem.

>>> Concept Checker

Fill in the blank(s) with the correct word(s), phrase, or mathematical statement.

51. The **addition** principle states that the equation $a = b$ is equivalent to the equation _____. $a \div c = b \div c$
52. The **subtraction** principle states that the equation $a = b$ is equivalent to the equation _____. $a + c = b + c$
53. The **multiplication** principle states that the equation $a = b$ is equivalent to the equation _____. $a - c = b - c$
54. The **division** principle states that the equation $a = b$ is equivalent to the equation _____. $a \cdot c = b \cdot c$

>>> Mastery Test

55. Solve: $8 = \frac{n}{2.3}$
56. Solve: $4.5 = 0.5r$
57. Solve: $x - 7.2 = 2.9$
58. Solve: $z + 5.2 = 7.4$
59. A student withdrew \$304.57 from her account. If the balance (the money left) in her account is \$202.59, how much money did she have in the account originally?
60. If you enter Interstate 75 at marker 49 traveling north, find the mile marker number after you travel
- 40 miles.
 - 120 miles.
 - m miles.
 - If your car breaks down and you use the phone at marker 256.8, how many miles have you traveled since you entered the interstate?

>>> Skill Checker

Perform the indicated operations.

61. $\frac{1}{7} + \frac{2}{5}$

62. $\frac{3}{8} + \frac{5}{12}$

63. $5\frac{3}{7} - 3\frac{4}{5}$

64. $6\frac{3}{8} - 5\frac{4}{7}$

> Collaborative Learning

Planets	Time of Revolution Around the Sun	Weight	Multiplier	Factor
Mercury	88 days	Earth weight	×	0.38
Venus	224.7 days	Earth weight	×	0.91
Earth	365.25 days	Earth weight	×	1.00
Mars	687 days	Earth weight	×	0.38
Jupiter	11.86 years	Earth weight	×	2.60
Saturn	29.46 years	Earth weight	×	1.10
Uranus	84.01 years	Earth weight	×	0.90
Neptune	164.8 years	Earth weight	×	1.20
Pluto*	248.5 years	Earth weight	×	0.08

* Pluto is not classified as a planet at this time.

On which planet will you become youngest? We will let you find out for yourself. *Hint:* The denominator has to be in days, for example, 88 days.

Now, for the weight issue. Suppose you weigh 130 pounds on Earth. How much would you weigh on Mercury? Since your weight is dependent on the laws of gravity of the planet you are visiting, your weight will change by the factor shown in the second table.

On Mercury, your weight would be: $130 \times 0.38 \approx 49$ pounds.

On which planet would your weight be the highest? You find out!

Suppose you want to become younger (in age) and trimmer (in weight). We can help you with that, but it will require a little travel. Let us start with the age issue. On Earth, a year is 365 days long but the year on other planets is dependent on the distance the planet is away from the sun. The first table shows the time it takes each of the planets to go around the sun. Now, suppose you are 18 years old. What is your Mercurian age? Since Mercury goes around the sun every 88 days, you would be much older! (You have been around more!) As a matter of fact your Mercurian age M would be $M = 18 \times \frac{365}{88} \approx 75$ years old.

Now, divide into three groups. The first group will handle the first three planets (Mercury, Venus, Earth), the second group will take Mars, Jupiter, and Saturn and the third group will have Uranus, Neptune, and Pluto.

Answer the following questions regarding your group and planet.

1. Find your age and weight on the planets assigned to your group.
2. On which of your assigned planets are you older? Younger?
3. What is the oldest age in all groups? The youngest?
4. What is the heaviest weight in all groups? The lightest?
5. If A_p is the age on your planet, A_e your age on Earth, and T_p the time of one revolution around the sun, based on your calculations, find a formula for A_p .
6. If W_p is the weight on your planet, W_e your age on Earth, and F_p the factor assigned to your planet, find a formula for W_p .

See, you can be younger and trimmer if you do a little travel.

You can check some of your work at <http://www.exploratorium.edu/ronh/weight/>.

Research Questions

1. Where did the decimal point first appear, in what year, and who used the decimal point?
2. Write a brief description of the decimal system we use, how it works, and how decimals are used.
Reference: <http://www.infoplease.com>.
3. Write a brief description of the Dewey decimal system, how it works, and for what it is used.
Reference: <http://www.mtsu.edu>.
4. Write a paragraph about Bartholomeus Pitiscus and the ways in which he used the decimal point.
5. Write a paragraph explaining where our decimal system comes from and its evolution throughout the years.
Reference: <http://www.scit.wlv.ac.uk>.

Summary Chapter 3

Section	Item	Meaning	Example
3.1A	Word names	The word name for a number is the number written in words.	The word name for 4.7 is four and seven tenths.
3.1B	Expanded form	Numeral written as a sum indicating the value of each digit.	$78.2 = 70 + 8 + \frac{2}{10}$
3.2B	Multiplying by powers of 10	A product involving 10, 100, 1000, and so on as a factor.	$93.78 \times 100 = 9378$
3.2D	Rounding decimals	Writing a decimal to a specified number of digits or places.	6.37 rounded to the nearest tenth is 6.4.
3.2E	Dividing by powers of 10.	A quotient whose divisor is 10, 100, 1000, and so on.	$386.9 \div 1000 = 0.3869$

(continued)

Section	Item	Meaning	Example
3.3A	Repeating decimal	A number whose decimal part repeats indefinitely.	$4.333 \dots$ and $92.\overline{63}$ are repeating decimals.
3.3B	Terminating decimal	A number whose decimal part ends.	3.5, 4.7123, and 3.1415 are terminating decimals.
3.4A	Arranging in order of decreasing magnitude	Arranging numbers from largest to smallest by using the $>$ (greater than) sign.	$3.7 > 3.6 > 3.5$
3.5A	Equivalent equations	Two equations are equivalent if they have the same solution.	$x + 9 = 10$ and $x + 9 - 9 = 10 - 9$ are equivalent.

Review Exercises Chapter 3

(If you need help with these exercises, look in the section indicated in brackets.)

1. **< 3.1A >** Give the word name.

- a. 23.389
- b. 22.34
- c. 24.564
- d. 27.8
- e. 29.67

2. **< 3.1B >** Write in expanded form.

- a. 37.4
- b. 59.09
- c. 145.035
- d. 150.309
- e. 234.003

3. **< 3.1C >** Add.

- a. $8.51 + 13.43$
- b. $9.6457 + 15.78$
- c. $5.773 + 18.0026$
- d. $6.204 + 23.248$
- e. $9.24 + 14.28$

4. **< 3.1C >** Add.

- a. $35.6 + 3.76$
- b. $43.234 + 4.8$
- c. $22.232 + 5.43$
- d. $33.23 + 7.89$
- e. $39.4217 + 8.34$

5. **< 3.1D >** Subtract.

- a. $332.45 - 17.649$
- b. $342.34 - 18.9$
- c. $323.32 - 45.045$
- d. $365.35 - 17.8$
- e. $43.56 - 19.9$

6. **< 3.2A >** Multiply.

- a. $3.14 \cdot 0.012$
- b. $2.34 \cdot 0.14$
- c. $3.45 \cdot 0.9615$
- d. $2.345 \cdot 0.016$
- e. $3.42 \cdot 0.3$

7. **< 3.2B >** Multiply.

- a. $0.37 \cdot 1000$
- b. $0.049 \cdot 100$
- c. $0.25 \cdot 10$
- d. $4.285 \cdot 1000$
- e. $0.945 \cdot 1000$

8. **< 3.2C >** Divide.

- a. $\frac{21.35}{0.35}$
- b. $\frac{57.33}{0.91}$
- c. $\frac{3.864}{0.042}$
- d. $\frac{2.9052}{0.36}$
- e. $\frac{3.7228}{0.041}$

9. **< 3.2D >** Round to the nearest tenth.

- a. 329.67
- b. 238.34
- c. 887.362
- d. 459.43
- e. 348.344

10. < 3.2D > Divide and round answers to two decimal digits.

- a. $80 \div 15$
- b. $90 \div 16$
- c. $48 \div 7$
- d. $84 \div 13$
- e. $97 \div 14$

11. < 3.2E > Divide.

- a. $3.12 \div 100$
- b. $4.18 \div 1000$
- c. $32.1 \div 100$
- d. $82.15 \div 10$
- e. $472.3 \div 100$

12. < 3.2F > Find the price per can.

- a. 6 cans for \$1.92
- b. 6 cans for \$2.04
- c. 6 cans for \$1.80
- d. 6 cans for \$1.68
- e. 6 cans for \$1.62

13. < 3.3A > Write as a decimal.

- a. $\frac{3}{5}$
- b. $\frac{9}{10}$
- c. $\frac{5}{2}$
- d. $\frac{3}{16}$
- e. $\frac{7}{8}$

14. < 3.3A > Write as a decimal.

- a. $\frac{1}{3}$
- b. $\frac{5}{6}$
- c. $\frac{2}{3}$
- d. $\frac{2}{7}$
- e. $\frac{1}{9}$

15. < 3.3B > Write as a reduced fraction.

- a. 0.38
- b. 0.41
- c. 0.6
- d. 0.03
- e. 0.333

16. < 3.3B > Write as a reduced fraction.

- a. 2.33
- b. 3.47
- c. 6.55
- d. 1.37
- e. 2.134

17. < 3.3C > Write as a reduced fraction.

- a. $0.\overline{45}$
- b. $0.\overline{08}$
- c. $0.\overline{080}$
- d. $0.\overline{004}$
- e. $0.\overline{011}$

18. < 3.3D >

- a. What decimal part of 16 is 4?
- b. What decimal part of 5 is 3?
- c. What decimal part of 12 is 6?
- d. What decimal part of 8 is 8?
- e. What decimal part of 16 is 3?

19. < 3.3D > A person's rent was \$300 per month. What decimal part went for rent if the monthly expenses were

- a. \$1500
- b. \$1200
- c. \$2100
- d. \$1000
- e. \$1800

20. < 3.4A > Arrange in order of decreasing magnitude and write using the > sign.

- a. 1.032, 1.03, 1.003
- b. 2.032, 2.03, 2.003
- c. 3.033, 3.03, 3.032
- d. 4.05, 4.052, 4.055
- e. 5.003, 5.03, 5.033

21. < 3.4A > Arrange in order of decreasing magnitude and write using the > sign.

- a. $1.2\overline{16}$, 1.216, $1.2\overline{16}$
- b. 2.336, $2.33\overline{6}$, $2.3\overline{36}$
- c. $3.2\overline{16}$, $3.2\overline{16}$, 3.216
- d. $4.5\overline{42}$, $4.5\overline{42}$, 4.542
- e. $5.1\overline{23}$, 5.123, $5.1\overline{23}$

22. < 3.4B > Fill in the blank with < or > so that the resulting inequality is true.

- a. $\frac{1}{11}$ _____ 0.09
- b. $\frac{2}{11}$ _____ 0.18
- c. $\frac{3}{11}$ _____ 0.28
- d. $\frac{4}{11}$ _____ 0.37
- e. $\frac{5}{11}$ _____ 0.45

23. < 3.4C > Find the $BMI = \frac{\text{weight}}{\text{height}^2} \times 703$ (to the nearest whole number) for a person who is

- a. 60 inches tall and weighs 150 pounds.
- b. 65 inches tall and weighs 150 pounds.
- c. 65 inches tall and weighs 200 pounds.
- d. 60 inches tall and weighs 200 pounds.
- e. 70 inches tall and weighs 160 pounds.

24. < 3.5A > Solve.

- a. $x + 3.6 = 7.9$
- b. $x + 4.6 = 6.9$
- c. $x + 5.4 = 5.9$
- d. $x + 6.3 = 9.9$
- e. $x + 7.2 = 9.9$

25. < 3.5A > Solve.

- a. $y - 1.4 = 5.9$
- b. $y - 1.5 = 6.2$
- c. $y - 7.42 = 5.9$
- d. $y - 4.2 = 5.8$
- e. $y - 7.8 = 3.7$

26. < 3.5A > Solve.

- a. $4.5 = 0.9y$
- b. $5.6 = 0.8y$
- c. $3.6 = 0.9y$
- d. $7.2 = 0.9y$
- e. $4.8 = 0.6y$

27. < 3.5A > Solve.

- a. $6 = \frac{z}{4.1}$
- b. $7 = \frac{z}{5.1}$
- c. $2 = \frac{z}{5.4}$
- d. $6.2 = \frac{z}{7.1}$
- e. $7 = \frac{z}{8.1}$

28. < 3.5B >

- a. The price of an item decreased by \$4.28 to \$39.95. What was the price of the item before?
- b. The price of an item decreased by \$3.01 to \$39.95. What was the price of the item before?
- c. The price of an item decreased by \$7.73 to \$39.95. What was the price of the item before?
- d. The price of an item decreased by \$6.83 to \$39.95. What was the price of the item before?
- e. The price of an item decreased by \$9.55 to \$39.95. What was the price of the item before?

> Practice Test Chapter 3

(Answers on page 264)

Visit www.mhhe.com/bello to view helpful videos that provide step-by-step solutions to several of the problems below.

1. Give the word name for 342.85.
2. Write 24.278 in expanded form.
3. $9 + 12.18 = \underline{\hspace{2cm}}$
4. $46.654 + 8.69 = \underline{\hspace{2cm}}$
5. $447.42 - 18.5 = \underline{\hspace{2cm}}$
6. $5.34 \cdot 0.013 = \underline{\hspace{2cm}}$
7. $0.43 \cdot 1000 = \underline{\hspace{2cm}}$
8. $\frac{252}{0.42} = \underline{\hspace{2cm}}$
9. Round 349.851 to the nearest tenth.
10. $70 \div 0.15 = \underline{\hspace{2cm}}$ (Round answer to two decimal digits.)
11. $4.18 \div 1000 = \underline{\hspace{2cm}}$
12. Carlos paid \$1.92 for 6 bottles of cola. What was the price per bottle?
13. Write $\frac{5}{8}$ as a decimal.
14. Write $\frac{1}{6}$ as a decimal.
15. Write 0.035 as a reduced fraction.
16. Write 3.41 as a reduced fraction.
17. Write $0.\overline{36}$ as a reduced fraction.
18. What decimal part of 12 is 9?
19. A person's rent is \$600 per month. If the person's total monthly expenses are \$1800, what decimal part goes for rent?
20. Arrange in order of decreasing magnitude and write using the $>$ sign.
 $8.2\overline{16}$ 8.216 $8.2\overline{1\overline{6}}$
21. Fill in the blank with $<$ or $>$ so that the resulting inequality is true.
 $\frac{6}{7} \underline{\hspace{1cm}} 0.86$
22. Find the BMI = $\frac{\text{weight}}{\text{height}^2} \times 703$ (to the nearest whole number) for a person who is 70 inches tall and weighs 175 pounds.
23. Solve $x + 3.6 = 8.9$.
24. Solve $2.7 = 0.3y$.
25. Solve $8 = \frac{z}{3.1}$.

► Answers to Practice Test Chapter 3

Answer	If You Missed		Review	
	Question	Section	Examples	Page
1. Three hundred forty-two and eighty-five hundredths	1	3.1	1	211
2. $20 + 4 + \frac{2}{10} + \frac{7}{100} + \frac{8}{1000}$	2	3.1	2	212
3. 21.18	3	3.1	3	213
4. 55.344	4	3.1	4, 5	213–214
5. 428.92	5	3.1	6, 7	215
6. 0.06942	6	3.2	1, 2	222–223
7. 430	7	3.2	3	223–224
8. 600	8	3.2	6, 7	225–226
9. 349.9	9	3.2	8	227
10. 466.67	10	3.2	9	227
11. 0.00418	11	3.2	10	228
12. \$0.32 or 32¢	12	3.2	11	228
13. 0.625	13	3.3	1	235
14. $0.1\bar{6}$	14	3.3	2	235–236
15. $\frac{7}{200}$	15	3.3	3	236–237
16. $\frac{341}{100}$	16	3.3	4	237
17. $\frac{4}{11}$	17	3.3	5	238
18. 0.75	18	3.3	6	238
19. $0.\bar{3}$	19	3.3	7, 8	239
20. $8.21\bar{6} > 8.2\bar{1}6 > 8.216$	20	3.4	1, 2	244–245
21. $<$	21	3.4	3, 4	245–246
22. 25	22	3.4	5, 6	246–247
23. $x = 5.3$	23	3.5	1	252
24. $y = 9$	24	3.5	3	252
25. $z = 24.8$	25	3.5	4	252

> Cumulative Review Chapters 1–3

1. Write $300 + 90 + 4$ in standard form.
2. Write three thousand, two hundred ten in standard form.
3. Write the prime factors of 20.
4. Write 60 as a product of primes.
5. Multiply: $2^2 \times 5 \times 5^0$
6. Simplify: $49 \div 7 \cdot 7 + 8 - 5$
7. Classify $\frac{5}{4}$ as proper or improper.
8. Write $\frac{11}{2}$ as a mixed number.
9. Write $5\frac{3}{8}$ as an improper fraction.
10. $\frac{2}{3} = \frac{?}{27}$
11. $\frac{5}{7} = \frac{25}{?}$
12. Multiply: $\frac{1}{2} \cdot 5\frac{1}{6}$
13. Multiply: $\left(\frac{7}{2}\right)^2 \cdot \frac{1}{49}$
14. Divide: $\frac{45}{4} \div 2\frac{7}{9}$
15. Add: $6\frac{2}{3} + 8\frac{3}{8}$
16. Subtract: $13\frac{1}{3} - 1\frac{3}{4}$
17. Translate and solve: $\frac{6}{7}$ less than a number z is $\frac{3}{5}$. What is z ?
18. Find a number such that $\frac{7}{8}$ of it is $3\frac{1}{2}$.
19. $3\frac{1}{2}$ pounds of sugar cost 49 cents. How much will 7 pounds cost?
20. Give the word name for 135.64.
21. Write 94.478 in expanded form.
22. Add: $46.654 + 9.69$
23. Subtract: $241.42 - 12.5$
24. Multiply: $5.98 \cdot 1.9$
25. Divide: $\frac{663}{0.39}$
26. Round 249.851 to the nearest ten.
27. Divide: $10 \div 0.13$ (Round answer to two decimal digits.)
28. Carlos paid \$3.04 for 8 bottles of cola. What was the price per bottle?
29. Write $\frac{5}{6}$ as a decimal.
30. Write 0.35 as a reduced fraction
31. Write $0.\overline{78}$ as a reduced fraction.
32. What decimal part of 15 is 3?
33. Teri's rent is \$200 per month. If Teri's total monthly expenses are \$2000, what fraction goes for rent?
34. Arrange in order of decreasing magnitude and write using the $>$ sign:
5.314 $5.3\overline{14}$ $5.3\overline{14}$
35. Insert $=$, $<$, or $>$ to make a true statement:
 0.26 _____ $\frac{13}{20}$
36. Solve for x : $x + 2.1 = 9.4$
37. Solve for y : $3.2 = 0.4y$
38. Solve for z : $7 = \frac{z}{4.8}$

This page intentionally left blank

- 4.1 Ratio
- 4.2 Rates
- 4.3 Proportions
- 4.4 Problem Solving
Involving Proportions

4

four

▶ Ratio, Rate, and Proportion

The Human Side of Mathematics

Leonardo who? Not Da Vinci, but Fibonacci, a man of few faces (no portrait of his face exists) but many names. Leonardo of Pisa, Leonardo Pisano, Pisano, Leonardo Fibonacci, or simply Fibonacci were a few. Fibonacci means “of the family of Bonacci” or “son of Bonacci,” but he sometimes called himself Leonardo Bigollo, “good for nothing or one of lesser importance” in the Venetian dialect or “traveler” in the Tuscan version.

His book, the *Liber Abaci* (*Book of Calculations*) published in 1202 began with the statement: “The nine Indian figures are 9 8 7 6 5 4 3 2 1. With these nine figures and with the sign of 0 any number may be written.” In Chapter 12 Fibonacci stated “the rabbit problem,” whose solution included a sequence of numbers now called the Fibonacci sequence. The sequence is:

$$1, 1, 2, 3, 5, 8, 13, 21, 34, 55 \dots$$

How do you construct such a sequence? It is easy!

To get the next number, add the last two.

Thus,

$$1 + 1 = 2 \quad (\text{Add the first two numbers to get the third.})$$

$$1 + 2 = 3 \quad (\text{Add the 2nd and 3rd numbers to get the 4th.})$$

$$2 + 3 = 5 \quad (\text{Add the 3rd and 4th numbers to get the 5th.})$$

$$3 + 5 = 8 \quad (\text{Add the 4th and 5th numbers to get the 6th.})$$

and so on. Want to learn more about it? Try the research questions at the end of the chapter!



4.1

Ratio

▶ Objectives

You should be able to:

A > Write a ratio as a reduced fraction.

▶ To Succeed, Review How To . . .

1. Reduce a fraction to lowest terms. (pp. 127–129)
2. Divide decimals. (pp. 226–228)
3. Divide mixed numbers. (pp. 140–141)

▶ Getting Started

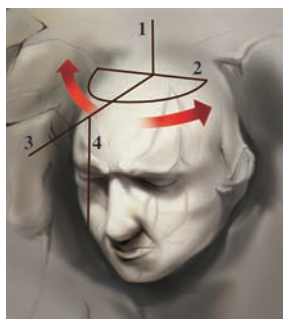

The photo shows sculptor Gutzon Borglum measuring a scale model of the presidents' busts carved on Mount Rushmore. The models were created on a 1 to 12 (1:12) inch **ratio**, that is, 1 inch on the model would be equivalent to 12 inches (1 foot) on the mountain. The transfer of the measurements was made using the “pointing machine” shown.

**A** > Writing Ratios as Reduced Fractions

We use ratios every day. For example, the student–teacher ratio in your school may be 25 to 1 (25:1) and the ratio of men to women in your class may be 12 to 15.

RATIO

A ratio is a comparison of two numbers or quantities measured with the same units.

The ratio 12 to 15 may be written as the **fraction** $\frac{12}{15}$ or $\frac{4}{5}$. When ratios are written as fractions, they are written in **reduced** form. Here are three ways to write ratios.

RATIO NOTATION:
WRITING RATIOS

Ratios can be written using each of the following notations:

$$a \text{ to } b \quad a:b \quad \frac{a}{b}$$

EXAMPLE 1 Expressing ratios as fractions

Express each of the following ratios as a fraction in reduced form.

- a. 1 to 6 b. 2 to 10 c. 4 to 22

SOLUTION 1

- a. The ratio 1 to 6 is written as $\frac{1}{6}$.
 b. The ratio 2 to 10 is written as $\frac{2}{10} = \frac{1}{5}$.
 c. The ratio 4 to 22 is written as $\frac{4}{22} = \frac{2}{11}$.

PROBLEM 1

Express each of the following ratios as a fraction in reduced form.

- a. 1 to 7 b. 3 to 15 c. 4 to 18

Note that in Example 1(b), $\frac{2}{10} = \frac{1}{5}$; that is, the pair of numbers 2 and 10 has the same ratio as the pair of numbers 1 and 5.

GREEN MATH

EXAMPLE 2 Twitter* Follower to Friend (TFF) Ratio**Jim Smith**

AKA: jimsmith

Followers: 6

Friends: 14

Updates: 1

Favorites: 0

TFF Ratio: 0.43

Do you know your TFF rate? It is the quotient (ratio) of how many **followers** you have divided by how many **friends** you have. Write the ratio for Jim Smith (see the box) as a reduced fraction and as a decimal to two places. What does the resulting ratio mean? You will have to learn how to interpret these ratios by going to the source!

Source: <http://tffratio.com/>.

SOLUTION 2

Jim Smith has 6 followers and 14 friends, so his TFF ratio is

$$\frac{6}{14} = \frac{3}{7}$$

To write $\frac{3}{7}$ as a decimal, divide 3 by 7 as shown.

Then round the 0.428 to two decimals (since 8 is greater than 5, add 1 to the 2, obtaining 0.43). This coincides with the TFF ratio of 0.43 given in the box.

* Note: **Twitter** is a free social networking service that enables its users to send and read other user's updates (*tweets*) displayed on the author's profile page and delivered to the author's subscribers (*followers*).

$$\begin{array}{r} 0.428 \\ 7 \overline{)3.000} \\ \underline{-28} \\ 20 \\ \underline{-14} \\ 60 \\ \underline{-56} \\ 4 \end{array}$$

PROBLEM 2

Find the TFF ratio for B Garza as a reduced fraction and as a decimal to two places.

B Garza

AKA: bgarza

Followers: 5

Friends: 6

Updates: 0

Favorites: 0

TFF Ratio: 0.83**EXAMPLE 3** Ratio of circumference to diameter

The ratio of circumference (distance around) to diameter (distance across the top) of a soda can is 7.26 inches to 2.31 inches. Write this ratio as a fraction in reduced form.

SOLUTION 3 The ratio is

$$\frac{7.26}{2.31}$$

PROBLEM 3

The ratio of circumference to diameter of a paint can is 10.78 to 3.43. Write this ratio as a fraction in reduced form.

(continued)

Answers to PROBLEMS

1. a. $\frac{1}{7}$ b. $\frac{1}{5}$ c. $\frac{2}{9}$ 2. $\frac{5}{6} = 0.83$ 3. $\frac{22}{7}$

Since it is easier to reduce a fraction without decimals, multiply the numerator and denominator of the fraction by 100 and then reduce:

$$\frac{7.26}{2.31} = \frac{7.26 \cdot 100}{2.31 \cdot 100} = \frac{726}{231} = \frac{242}{77} = \frac{22}{7}$$

The ratio of circumference to diameter of any cylindrical can is the number π (pi), which is about 3.1416. It is also approximated by $\frac{22}{7}$.

EXAMPLE 4 Ratio of the wage gap

The wage gap is a statistical indicator often used as an index of the status of women's earnings relative to men's.

- Women earn 78 cents for every dollar (100 cents) men make. Write the ratio of 78 to 100 as a fraction in reduced form.
- African-American women earn 64 cents for every dollar earned by Caucasian men. Write the ratio of 64 to 100 as a fraction in reduced form.

SOLUTION 4

$$\text{a. } \frac{78}{100} = \frac{39}{50} \qquad \text{b. } \frac{64}{100} = \frac{\cancel{4} \cdot 16}{\cancel{4} \cdot 25} = \frac{16}{25}$$

EXAMPLE 5 Aspect ratio and HDTV

The aspect ratio of the picture in a high-definition television (HDTV) is 16:9 and is defined as the ratio of the width to the height of the TV picture. A Panasonic television is $32\frac{1}{2}$ wide and $22\frac{2}{3}$ high.



- What is the ratio of the width to the height of the set?
- Do the dimensions follow the ratio 16:9?

SOLUTION 5

- The width ($32\frac{1}{2}$) to height ($22\frac{2}{3}$) ratio is

$$\frac{32\frac{1}{2}}{22\frac{2}{3}} = \frac{\frac{65}{2}}{\frac{68}{3}} = \frac{65}{2} \cdot \frac{3}{68} = \frac{195}{136}$$

- When written as a fraction, 16:9 is $\frac{16}{9} \approx 1.8$ but $\frac{195}{136} \approx 1.4$, so the dimensions of the television do not follow the ratio 16:9.

PROBLEM 4

- In 1963, women earned 58 cents for every dollar earned by men. Write the ratio of 58 to 100 as a reduced fraction.
- Hispanic women earn 52 cents for every dollar earned by white men. Write the ratio of 52 to 100 as a fraction in reduced form.

PROBLEM 5

A television set is $32\frac{1}{2}$ inches wide and $20\frac{2}{3}$ inches high.

- What is the ratio of the width to the height of the set?
- Do the dimensions follow the ratio 16:9?

GREEN MATH

EXAMPLE 6 The U.S. and the environment

It has been claimed that the United States produces far less greenhouse gases per barrel of oil burned than China, India, Russia, and almost every other major player in the world oil market. How can we prove it? By using the ratio of how much of the world greenhouse gases the United States produces (20.6%) to how much of the world oil the United States consumes (25.4%). Find this ratio as a reduced fraction and as a decimal to two places.

PROBLEM 6

China produces 14.8% of the world's greenhouse gases while consuming 7.57% of the world's oil. What is China's ratio of greenhouse gases produced to oil consumed? Write the answer as a fraction and as a decimal to two places.

Answers to PROBLEMS

4. a. $\frac{29}{50}$ b. $\frac{13}{25}$ 5. a. $\frac{195}{124}$ b. No 6. $\frac{14.8}{7.57} = \frac{1480}{757} = 1.96$

SOLUTION 6

We need the ratio of 20.6% to 25.4%, which is

$$\frac{20.6}{25.4} = \frac{206}{254} = \frac{103}{127}$$

Note that we first multiplied the numerator (20.6) and denominator (25.4) by 10 and then reduced the fraction. To find the answer as a decimal to two places divide 103 by 127, as shown, then round the 0.811 to two decimal places, obtaining 0.81. This means that the United States produces 0.81 units of greenhouse gases for every unit of oil it consumes.

Source: <http://tinyurl.com/mncxj7>.

$$\begin{array}{r} 0.811 \\ 127 \overline{)103.000} \\ \underline{-1016} \\ 140 \\ \underline{-127} \\ 130 \\ \underline{-127} \\ 3 \end{array}$$

Exercises 4.1

> Practice Problems > Self-Tests
> Media-rich eBooks > e-Professors > Videos

A Writing Ratios as Reduced Fractions In Problems 1–10, write the given ratio as a fraction in reduced form.

- | | | | | |
|------------|------------|------------|----------------|-----------------|
| 1. 3 to 8 | 2. 4 to 17 | 3. 5 to 35 | 4. 8 to 64 | 5. 32 to 4 |
| 6. 40 to 8 | 7. 11 to 3 | 8. 13 to 9 | 9. 0.5 to 0.15 | 10. 0.6 to 0.24 |

TFF ratios Recall from Example 2 that the **TFF** (Twitter Follower-Friend) ratio is the quotient (ratio) of how many **followers** you have divided by how many **friends** you have. The results are interpreted as follows:

- Less than 1: You are seeking knowledge and friends
 - Around 1: You are respected among your peers
 - 2 or above: You are a popular person and people want to hear what you have to say.
11. Find the TFF (to two decimal places) and interpret the results for Janet Jones.
12. Find the TFF (to two decimal places) and interpret the results for M. Escher.

Janet Jones
AKA: janetjones
Followers: 21
Friends: 4
Updates: 28
Favorites: 0
TFF Ratio: 5.25

M. Escher
AKA: mescher
Followers: 1
Friends: 2
Updates: 1
Favorites: 0
TFF Ratio: 0.50

13. Find the TFF (to two decimal places) and interpret the results for L. Davinci.
14. Find the TFF (to two decimal places) and interpret the results for S. Germain.

L. Davinci
AKA: ldavinci
Followers: 15
Friends: 68
Updates: 113
Favorites: 0
TFF Ratio: 0.22

S. Germain
AKA: sgermain
Followers: 7
Friends: 6
Updates: 48
Favorites: 0
TFF Ratio: 1.17

15. Find the TFF (to two decimal places) and interpret the results for Randy Welch.

Randy Welch
AKA: RandyWelch
Followers: 0
Friends: 4
Updates: 0
Favorites: 0
TFF Ratio: 0.00

16. Find the TFF (to two decimal places) and interpret the results for Adam Fischer.

(Hint: The answer provided is not correct!)

Adam Fischer
AKA: adamfischer
Followers: 2
Friends: 0
Updates: 0
Favorites: 0
TFF Ratio: 0.00

17. *Best gaps* Women in special education earn 103 cents for every dollar (100 cents) earned by men. Write the ratio of 103 to 100 as a fraction in reduced form and as a decimal to two places.
18. *Best gaps* Female postal service clerks earn 104 cents for every 100 cents earned by male postal service clerks. Write the ratio of 104 to 100 as a fraction in reduced form and as a decimal to two places.
19. *Worst gaps* Female financial managers earn 63 cents for every 100 cents earned by male financial managers. Write the ratio of 63 to 100 as a fraction in reduced form and as a decimal to two places.
20. *Worst gaps* Female physicians and surgeons earn 60 cents for every 100 cents earned by male physicians and surgeons. Write the ratio of 60 to 100 as a fraction in reduced form and as a decimal to two places.
21. *Wage gap in Canada* In 2006, Canadian women earned 85.9 cents for every dollar (100 cents) earned by Canadian men. Write the ratio of 85.9 to 100 as a fraction in reduced form and as a decimal to two places.
22. *Wage gap in Canada* By 2007, the gap in Problem 21 had improved to 87.4 to 1 dollar (100 cents). Write the ratio 87.4 to 100 as a fraction in reduced form and as a decimal to two places.

The following information will be used in Exercises 23–30.

Have you measured your cholesterol lately? Your lab report will include results for total cholesterol (TC), LDL (low density lipoprotein), HDL (high density lipoprotein), and triglycerides. What do the results mean? Researchers and health-care providers are divided on the effectiveness of TC/HDL ratios for predicting the chances of developing heart disease. Similarly, the medical community is divided on whether the LDL/HDL ratio is better than total cholesterol or LDL cholesterol levels in predicting a person's risk for heart disease. Nonetheless, suggestions to protect or warn you against heart attacks are provided in the table.

Blood Cholesterol Ratios		
	Protective	Warning
TC/HDL	Less than 4.2	4.3 and higher
LDL/HDL	Less than 2.5	2.6 and higher

Source: <http://www.all-about-lowering-cholesterol.com/cholesterol-level-scale.html>.

In Exercises 23–26, find the TC/HDL ratio for a person with the given TC and HDL values. Give the answers to two decimal places and interpret the results using the table.

23. TC = 180 and HDL = 50

24. TC = 220 and HDL = 40

25. TC = 190 and HDL = 40

26. TC = 220 and HDL = 54

In Exercises 27–30, find the LDL/HDL ratio for a person with the given LDL and HDL values. Give the answers to two decimal places and interpret the results using the table.

27. LDL = 140 and HDL = 30.

28. LDL = 110 and HDL = 50.

29. LDL = 90 and HDL = 46.

30. LDL = 117 and HDL = 45.

- 31. Challenge Index** The Challenge Index is the total number of Advanced Placement (AP) or International Baccalaureate (IB) tests given at a school in May, divided by the number of seniors graduating in June.
- Find the Challenge Index written as a reduced fraction for New Trier High in Winnetka, Illinois, which gave 1918 AP tests and graduated 970 seniors.
 - Write the answer to part **a** as a decimal rounded to three places.
- 32. Challenge Index** The Challenge Index is the total number of AP or IB tests given at a school in May, divided by the number of seniors graduating in June.
- Find the Challenge Index written as a reduced fraction for Ottawa Hills High in Toledo, Ohio, which gave only 154 AP tests but also graduated only 78 seniors.
 - Write the answer to part **a** as a decimal rounded to three places.

Source: For Problems 31 and 32: <http://www.msnbc.msn.com>.

Applications: Green Math

2008 Green Gap Survey.

Source: <http://www.coneinc.com/content1136>.

- 33.** Americans misunderstand key phrases commonly used in environmental marketing and advertising. 48 out of 100 Americans erroneously believes a product marketed as “green” or “environmentally friendly” has a positive (i.e., beneficial) impact on the environment. Write 48 out of 100 as a reduced fraction, a decimal, and a percent.
- 34.** Only 22 out of 100 understand these terms more accurately describe products with less negative environmental impact than previous versions or competing products. Write 22 out of 100 as a reduced fraction, a decimal, and a percent.

Using Your Knowledge

Ratios are used in business to measure **liquidity** (the ability to pay short-term debts), **profit**, and **solvency** (ability to pay debts). Here is the definition of some of these ratios:

$$\text{current ratio} = \frac{\text{current assets}}{\text{current liabilities}}$$

$$\text{net profit margin} = \frac{\text{net profits}}{\text{net sales}}$$

$$\text{debt-to-assets ratio} = \frac{\text{total liabilities}}{\text{total assets}}$$

Suppose a business has \$15,000 in current assets, \$8000 in current liabilities, \$60,000 in total assets, and \$60,000 in total liabilities.

- 35.** Write the current ratio for the business as a fraction in reduced form.
- 36.** Write the debt-to-assets ratio for the business as a fraction in reduced form.
- 37.** The net sales of a business amounted to \$50,000. If net profits were \$8000, what was the net profit margin?

Write On

- 38.** Explain in your own words what a ratio is.
- 39.** Is the TFF for H. Lopez correct? Explain.
- 40.** Is “30 miles per gallon” a ratio? Explain.

<p>H. Lopez AKA: hlopez Followers: 1 Friends: 0 Updates: 0 Favorites: 0 TFF Ratio: 0.00</p>

Concept Checker

Fill in the blank(s) with the correct word(s), phrase, or mathematical statement.

- 41.** A **ratio** is a _____ of two numbers.
- 42.** The **ratio** of a to b can be written **three** ways: _____, _____ and _____.

$$\frac{a}{b}$$

$$b : a$$

$$a \text{ to } b$$

$$a : b$$

quotient

$$\frac{b}{a}$$

$$b \text{ to } a$$

Mastery Test

- 43.** The ratio of registered vehicles to people in Madison, Wisconsin, is 170,000 to 210,000. Write this ratio as a fraction in reduced form.
- 44.** The ratio of width to length for an American flag is 10 to 19. Write this ratio as a fraction in reduced form.

>>> Skill Checker

Reduce to lowest terms.

45. $\frac{350}{1000}$

46. $\frac{3.5}{100}$

47. $\frac{4.8}{3.2}$

48. $\frac{6.4}{3.2}$

Write as a decimal rounded to two decimal places.

49. $\frac{5000}{18}$

50. $\frac{861}{82}$

4.2 Rates

▶ Objectives

You should be able to:

A > Write a rate as a reduced fraction with the correct units.

B > Write unit rates and use them to compare prices.

▶ To Succeed, Review How To . . .

1. Round numbers. (pp. 226–227)
2. Reduce a fraction to lowest terms. (pp. 127–129)
3. Write a fraction as a decimal. (pp. 234–236)

▶ Getting Started

The table gives the *rates* for printing a classified ad. In the preceding section, we used *ratios* to compare *like quantities* such as circumference to diameter (both in inches) or width to length (both in feet). When a ratio is used to compare *unlike quantities* (quantities with different units), such as cost per day, or miles per gallon, we call it a **rate**.

Local Noncontract Classified Rates (per-day rates)

Days	Noncommissionable	
	3-Line Min. Line Rate	4-Inch Min. Inch Rate
Sunday only	\$5.09	\$71.22
1 day	\$4.49	\$62.86
2–5 days	\$3.69	\$51.74
6–10 days	\$3.48	\$48.78
11–15 days	\$3.30	\$46.14
16+ days	\$3.09	\$43.26

Source: Newspaper Agency Corporation.

A > Writing Rates

RATES

A rate is a comparison of two numbers or quantities often measured with different units. You can think of a **rate** as a ratio used to compare two *different* kinds of measures such as miles per gallon or cents per pound.

According to the chart in the *Getting Started*, suppose you wish to run an ad one time on Sunday (first line in the table). The cost will be \$5.09 per line. This *rate* is written as $\frac{\$5.09}{\text{line}}$. (Note that *per* indicates division.) Similarly, if your car travels 200 miles on 8 gallons of gas, the miles-per-gallon rate can be written: $\frac{200 \text{ miles}}{8 \text{ gallons}}$, or $25 \frac{\text{miles}}{\text{gallon}}$, or 25 miles per gallon, or 25 mi/gal, or 25 mpg.

EXAMPLE 1 Writing a rate

One of the highest rates ever offered a writer was \$30,000 to Ernest Hemingway for a 2000-word article on bullfighting. Find the rate per word. (Per-word rates for magazine writers are around \$1.60/word!) (The article was published by *Sports Illustrated*.)

SOLUTION 1 We want to find how many dollars per word, so we divide:

$$\frac{30,000 \text{ dollars}}{2000 \text{ words}} = \$15 \text{ per word}$$

PROBLEM 1

John Creasey published 564 books over a 41-year period (1932–1973). To the nearest whole number, how many books per year is that?

EXAMPLE 2 Writing a rate

What is the miles-per-gallon rate for your car? Two automotive engineers named Craig Henderson and Bill Green traveled 1759 miles on 17 gallons of gas (from Dodger Stadium to Vancouver, B.C.). What was their miles-per-gallon rate? (Round the answer to the nearest whole number.)

SOLUTION 2 To find miles per gallon, we divide 1759 by 17.

$$\begin{array}{r} 103.4 \\ 17 \overline{)1759.0} \\ \underline{17} \\ 059 \\ \underline{51} \\ 80 \\ \underline{68} \\ 12 \end{array}$$

Thus, their rate was about 103 miles per gallon (rounded from 103.4).

PROBLEM 2

Lionel Harrison and E. A. Ferguson drove 1900 miles from London to Moscow on 62 gallons of gas. What was their mile-per-gallon rate? (Round the answer to the nearest whole number.)

EXAMPLE 3 Writing a rate

An 18-pound bag of lawn food covers 5000 square feet of lawn. To the nearest whole number, what is the rate of coverage in square feet per pound?

SOLUTION 3 Here we want square feet per pound, so we divide 5000 by 18 (remember *per* means divide). We have

$$\begin{array}{r} 277.7 \\ 18 \overline{)5000.0} \\ \underline{36} \\ 140 \\ \underline{126} \\ 140 \\ \underline{126} \\ 140 \\ \underline{126} \\ 14 \end{array}$$

Thus, the rate of coverage is about 278 square feet per pound $\left(\frac{278 \text{ square feet}}{1 \text{ pound}}\right)$.

PROBLEM 3

An 18-pound bag of lawn food costs \$6. To the nearest cent, what is the cost per pound?

EXAMPLE 4 Writing a rate

Natasha Bello is a Pharm. D intern at a drugstore. She earned \$861 the first two weeks in the summer.

- What was her rate of pay per week, that is, how much did she make each week?
- If she worked a total of 82 hours, what was her hourly rate of pay?

PROBLEM 4

Randy works in the mathematics department and earned \$612 the first two weeks in the summer.

- How much did he make each week?
- If he worked a total of 72 hours, what was his hourly rate of pay?

(continued)

Answers to PROBLEMS

1. 14 2. 31 3. 33¢ 4. a. \$306 per week b. \$8.50 per hour

SOLUTION 4

- a. The rate of pay *per week* is the ratio of the money earned (\$861) divided by the length of time she worked (2 weeks).

$$\frac{\$861}{2 \text{ weeks}} = 430.50 \frac{\text{dollars}}{\text{week}} \text{ or } \$430.50 \text{ per week}$$

- b. The rate of pay *per hour* is the ratio of the money earned (\$861) divided by the number of hours she worked (82 hours).

$$\frac{\$861}{82 \text{ hours}} = 10.50 \frac{\text{dollars}}{\text{hour}} \text{ or } \$10.50 \text{ per hour}$$

$$\begin{array}{r} 10.5 \\ 82 \overline{)861.0} \\ \underline{82} \\ 410 \\ \underline{410} \\ 0 \end{array}$$

Using the same ideas as in Example 4, we can calculate how many trees there are per person ($\frac{\text{trees}}{\text{person}}$) in the world! We will actually do this in Example 5.

GREEN MATH

EXAMPLE 5 Trees per person in the world

Assuming there are 400 billion trees in the world and roughly 7 billion people inhabiting it, calculate how many trees per person there are in the world. (See and hear the story at <http://tinyurl.com/5m59zo>.)

SOLUTION 5

We have to calculate the **rate** of trees to people. Since there are 400 billion trees and 7 billion people in the world, the rate is $\frac{\text{trees}}{\text{people}} = \frac{400 \text{ billion trees}}{7 \text{ billion people}} = \frac{400}{7} = 57.1 \approx 57$ trees per person.

PROBLEM 5

The original estimate (in 2005) was made using 400 billion trees and 6 billion people. How many trees were there per person then?

If you want more exact numbers, the world population is **6,779,750,420** and the number of trees 400,246,300,201 according to NASA!

B > Unit Rates

Most supermarkets help you compare prices by posting the **unit price** for the items.

UNIT RATE

A unit rate is a rate in which the denominator is 1.

Thus, if a 5-pound bag of potatoes costs 90¢, the cost per pound is

$$\frac{90¢}{5 \text{ pounds}} = \frac{18¢}{1 \text{ pound}}$$

and the unit price is 18¢ per pound. Note that per pound indicates per *one* pound.

Answers to PROBLEMS

5. 66.6 or 67 trees per person

EXAMPLE 6 Calculating the unit price

A 30-ounce jar of gourmet popping corn costs \$3.99. What is the unit price in cents per ounce?

SOLUTION 6

$$\frac{\$3.99}{30 \text{ ounces}} = \frac{399\text{¢}}{30 \text{ ounces}}$$

$$\begin{array}{r} 13.3 \\ 30 \overline{)399.0} \\ \underline{30} \\ 99 \\ \underline{90} \\ 90 \\ \underline{90} \\ 0 \end{array}$$

Thus, the unit price is $\frac{13.3\text{¢}}{1 \text{ ounce}} = 13.3\text{¢}$ per ounce.

PROBLEM 6

A 10-ounce jar of microwave popping corn costs \$1.89. What is the unit price in cents per ounce?

Unit prices will help you to find the best buy when comparing prices. Thus, if the $1\frac{1}{2}$ -pound container of brand X gourmet popcorn is selling for \$1.80, is it a better buy than the popcorn of Example 6? To be able to compare prices, we must find the total number of ounces in brand X.

Since 1 pound = 16 ounces, $1\frac{1}{2}$ pounds = 16 ounces + 8 ounces = 24 ounces. The price per ounce of brand X is

$$\frac{180\text{¢}}{24 \text{ ounces}} = \frac{7.5\text{¢}}{1 \text{ ounce}} = 7.5\text{¢ per ounce}$$

Thus, brand X is a better buy.

EXAMPLE 7 Calculating the unit price

A 12-ounce bottle of gourmet popcorn oil sells for \$1.99. The 24-ounce brand X bottle costs \$3.99. Which is the better buy?

You can reason like this:

Gourmet : 12 ounces sell for \$1.99.

Brand X : 24 ounces (*twice* as much) should cost *twice* as much, or $\$2 \cdot 1.99 = \3.98 . But brand X sells for \$3.99 (too much); the gourmet popcorn oil is a better buy. But can you prove it? Let's see.

SOLUTION 7 We compare unit prices to the nearest hundredth of a cent.

$$\text{Gourmet: } \frac{199\text{¢}}{12 \text{ ounces}}$$

$$\begin{array}{r} 16.58 \\ 12 \overline{)199.00} \\ \underline{12} \\ 79 \\ \underline{72} \\ 70 \\ \underline{60} \\ 100 \\ \underline{96} \\ 4 \end{array}$$

Thus, Gourmet $\approx \frac{16.58\text{¢}}{1 \text{ ounce}} = 16.58\text{¢}$ per ounce.

PROBLEM 7

A 29-ounce jar of spaghetti sauce costs \$1.09. The 24-ounce bottle costs 89¢. Which is the better buy?

(continued)

Answers to PROBLEMS

6. 18.9¢ 7. 24-ounce bottle

$$\text{Brand X: } \frac{399\text{¢}}{24 \text{ ounces}}$$

$$\begin{array}{r} 16.625 \\ 24 \overline{)399.000} \\ \underline{24} \\ 159 \\ \underline{144} \\ 150 \\ \underline{144} \\ 60 \\ \underline{48} \\ 120 \\ \underline{120} \\ 0 \end{array}$$

Thus, brand X $\approx \frac{16.63\text{¢}}{1 \text{ ounce}} = 16.63\text{¢}$ per ounce.

Thus, the gourmet popcorn oil at 16.58¢ per ounce is a better buy.

Exercises 4.2



> Practice Problems > Self-Tests
> Media-rich eBooks > e-Professors > Videos

< A > Writing Rates In Problems 1–10, write the indicated rates.

- 1. Rate of pay per hour** A student is paid at the rate of \$38 for 8 hours of work. What is the rate per hour?
- 2. Construction worker's pay** According to the Bureau of Labor Statistics, the average construction worker makes \$760 a week and works 40 hours. What is the rate per hour?
- 3. Calculating miles per gallon** A car uses 12 gallons of gas on a 258-mile trip. How many miles per gallon is that?
- 4. Miles per gallon** A student traveled 231 miles in going from Houston to Dallas. If she used 12 gallons of gas, how many miles per gallon did her car get?
- 5. Plane's rate of travel** A plane flew from Boston to Chicago in 1.5 hours. If the air distance between these two cities is 840 miles, what was the plane's rate of travel?
- 6. Plane's rate of travel** The air distance between New York and Dallas is 1375 miles. If a plane takes $2\frac{1}{2}$ hours to make the flight, what is the plane's rate of travel?
- 7. More flying** One of the fastest flights in the continental United States was made by Captain Robert G. Sowers. He flew 2459 miles from Los Angeles to New York in 2 hours. What was his rate of travel?
- 8. Marathon runner** One of the fastest marathon runners is Balaine Desimo, who completed 26 miles in 2.1 hours. To the nearest mile, what was his rate of travel?
- 9. Tortilla rate of consumption** Tom Nall ate 74 tortillas in 30 minutes at Mariano's Mexican Restaurant in Dallas, Texas. To the nearest tenth, what was his per-minute rate of consumption?
- 10. Refinery rate of production** The Amerada Hess refinery in St. Croix produced 345,000 barrels of oil a day. What is the rate of production in barrels per hour?

< B > Unit Rates In Problems 11–20, write each rate as a unit rate.

- 11. Calories per gram of hamburgers** A McDonald's hamburger has 263 calories and weighs 100 grams. Find the number of calories per gram.
- 12. Calories per gram of hamburgers** A Burger King hamburger has 275 calories and weighs 110 grams. Find the number of calories per gram.
- 13. Rate of cars serviced in one hour** A car dealership services 90 cars in an average day. If the service department operates 7.5 hours each day, at what rate per hour are cars serviced?
- 14. Monthly sales per person** A car dealership has 16 salespersons and sold 104 cars during the last month. What was the monthly number of sales per salesperson?

- 15. Bamboo growth rate** Which is the fastest-growing plant you know? A bamboo plant grew 36 inches in a 24-hour period. What was the hourly growth rate for this plant?
- 17. Caloric content of avocados** The fruit with the *highest* caloric value is the avocado: $1\frac{1}{2}$ pounds of edible avocado contain 1110 calories. What is the caloric rate per edible pound?
- 19. Scoring rate for Wilt Chamberlain** Wilt Chamberlain scored 31,419 points in 1045 basketball games. To the nearest tenth, at what rate was he scoring per game?
- 16. Daily growth rate for tomato plants** At the Tsukuba Science Expo in Japan it was announced that a *single* tomato plant produced 12,312 tomatoes in 347 days. To the nearest tenth, what was the daily rate at which tomatoes were growing on this plant?
- 18. Caloric content of cucumbers** The fruit with the *lowest* caloric value is the cucumber. A $1\frac{1}{2}$ -pound cucumber has 109.5 calories. What is the caloric rate per pound of cucumbers?
- 20. Points per season** Kareem Abdul-Jabbar scored 38,987 points in 20 seasons. To the nearest whole number, how many points per season did he score?

Enrollment costs Have you taken a course to enhance your personal or professional skills? Here are some courses, their length, and their cost. In Problems 21–26, find the cost per hour to the nearest cent.

	Course	Cost	Hours
21.	Business Survival Skills	\$872	84
22.	Introduction to Microsoft Word	\$87	8
23.	Using Websites to Improve Your Bottom Line	\$87	4
24.	Who Moved my Cheese?®	\$97	4
25.	PC Repair and Troubleshooting	\$895	35
26.	Microsoft Windows Professional	\$698	21

- 27. Animal facts** Elephants eat more than 1400 pounds of food (hay, grain, fruit, and vegetables) a week. How many pounds of food per day can an elephant consume?
- 29. Animal facts** An American alligator lives about 40 years and, during that time, grows about 3000 teeth. How many teeth per year is that?
- 28. Animal facts** An elephant drinks 770 gallons of water each week. How many gallons a day can an elephant drink?
- 30. Animal facts** A llama can travel 60 miles in three days. How many miles per day can a llama travel?

Unit prices In Problems 31–36, find each unit price (to the nearest cent) and determine which size has the lowest unit price.

- 31.**  Close-Up
Classic Red Gel Regular 6 oz \$2.29
-  Close-Up
Classic Red Gel Regular 4 oz \$1.59
- 32.**  Smooth 'N Shine
Instant Repair Spray-On Polisher 4 oz \$4.99
-  Frizz-Ease
Relax Wave-Maker Styling Spray 6 oz \$6.99
Ripple Effect
- 33.**  Walgreens
Fruit Chews Candy Assorted 26 oz \$1.99
-  Walgreens
Gum Drops 11 oz \$0.99
- 34.**  Nabisco
SnackWell's Cookies Creme Sandwich 7.75 oz \$2.79
-  Nabisco
Sociables Baked Savory Crackers 8 oz \$2.99

35.



Dry Idea
Anti-Perspirant & Deodorant Roll-On Powder Fresh 2.5 oz \$4.49



Lady Mitchum
Anti-Perspirant & Deodorant Roll-On Powder Fresh Scent 1.5 oz \$3.79

36.



2386720
Advil Caplet 100 CT \$7.99



2754968
Advil Caplet 165 CT \$11.99

37. *Is cheaper always better?* As a consumer, you probably believe that cheaper is *always* better. If you do, read on.

- Dermessage dishwashing liquid costs \$1.31 for 22 ounces. To the nearest cent, what is the cost per ounce?
- White Magic dishwashing liquid costs \$1.75 for 32 ounces. To the nearest cent, what is the cost per ounce?
- Based on price alone, which is the better buy, Dermessage or White Magic?

But how much do you use per wash? *Consumer Reports* estimated that it costs 10¢ for 10 washes with Dermessage and 18¢ for the same number of washes with White Magic. Dermessage is a better buy!

39. *Completion rate* The University of Minnesota defines the completion rate as the quotient of hours completed divided by hours attempted. For example, if you have completed **30** credit hours out of **40** attempted your completion ratio is

$$\frac{30}{40} = \frac{3}{4} = \frac{3 \cdot 25}{4 \cdot 25} = \frac{75}{100}$$

This is a 75% (per hundred) completion rate.

- Find the completion rate written as a reduced fraction for a student who completed 40 credit hours out of 50 attempted.
- Write the answer in **a** with a denominator of 100.
- What is the student's completion rate as a percent?

Source: <http://www.umn.edu>.

38. *Is cheaper always better?* A&P wool-washing liquid costs 79¢ for 16 ounces. Ivory Liquid is \$1.25 for 22 ounces.

- To the nearest cent, what is the price per ounce of the A&P liquid?
- To the nearest cent, what is the price per ounce of the Ivory Liquid?
- Based on price alone, which is the better buy?

But wait. How much do you have to use? According to *Consumer Reports*, it costs 17¢ for 10 washes with the A&P liquid, but only 12¢ for 10 washes with Ivory Liquid!

For an article on these and other comparisons, see the *Consumer Reports* issue on washing liquid costs.

40. *Completion rate*

- Find the completion rate to three decimal places of a student who completed 60 credit hours out of 90 attempted
- What is the student's completion rate as a percent?
- What is the student's completion rate if part **a** is first rounded to the nearest integer?
- Remember, to qualify for financial aid you need a minimum completion rate of 67%. Does the student in part **b** qualify?
- Does the student in part **c** qualify?

See how important rounding is?

	Fall	Spring	Total
Attempted credits	22	18	40
Failures, incompletes, no passes and withdrawals	2	8	10
Completed credits	20	10	

30 completed/40 attempted = 75% completion rate.

Applications: Green Math

In Example 5, we discussed trees. Let us expand and include some facts about the *rain forest*, a very dense, relatively warm, wet forest that can be tropical, subtropical, or temperate.

- 41.** It is estimated that a single hectare (2.5 acres) of Amazon rain forest contains about 900 tons of living plants, including more than 750 types of trees and 1500 other plants.
- How many living plants per acre is that?
 - How many types of trees per acre is that?
 - How many other plants per acre is that?
- 42.** A typical 4-square-mile patch of rain forest contains as many as 1500 flowering plants, 750 species of trees, 400 species of birds, and 150 species of butterflies.
- How many flowering plants per square mile is that?
 - How many species of trees per square mile is that?
 - How many species of birds per square mile is that?
 - How many species of butterflies per square mile is that?
- 43.** Unfortunately, the rain forest is being lost because the trees are being cut for logging, farming, cattle raising, and development. It is estimated that three acres of the rain forest are lost every 2 seconds. How many acres per second is that?
- 44.** A different estimate indicates that we are (globally) losing 3,338,000 acres of tropical forests per year. Assuming a year has 365 days
- To one decimal place, how many acres per day is that?
 - To one decimal place, how many acres per hour is that?
 - To one decimal place, how many acres per minute is that?
 - To one decimal place, how many acres per second is that?

Using Your Knowledge

Classified Rates Look at the rate chart at the beginning of this section. It tells you how much you have to pay per line for a specified period of time. For example, if you run an ad for 15 days (3-line minimum), the rate is \$3.30 per line. This means that if your ad has 5 lines and it runs for 15 days, the cost will be $5 \cdot \$3.30 \cdot 15 = \247.50 . Now, let us do the reverse process.

- 45.** Suppose you paid \$348 for a 10-line ad running for 10 days.
- How much did you pay each day?
 - What was your line-per-day rate?
- 46.** Suppose you paid \$168 for a 7-line ad running 8 days.
- How much did you pay per day?
 - What was your line-per-day rate?

Write On

- 47.** Is a ratio always a rate? Explain and give examples.
- 48.** Is a rate always a ratio? Explain and give examples.
- 49.** Write in your own words the procedure you use to find a unit rate.
- 50.** When you say that your car gets 25 miles per gallon, is 25 miles per gallon
- a ratio?
 - a rate?
 - a unit rate?

Concept Checker

Fill in the blank(s) with the correct word(s), phrase, or mathematical statement.

- 51.** A _____ is a **ratio** used to compare two **different** kinds of measures.
- 52.** A **rate** in which the denominator is 1 is called a _____ rate.

fraction	simplified
rate	unit
proportion	

Mastery Test

- 53.** A 6-ounce tube of toothpaste costs \$2.30. What is the unit price in cents per ounce? (Answer to one decimal place.)
- 54.** A can of spray costs \$3.99 for 4 ounces. Another brand costs \$5.99 for 6 ounces. Which can is the better buy?
- 55.** A student earned \$508.40 in a 2-week period.
- What was the rate of pay per week?
 - If the student worked 82 hours, what was the rate of pay per hour?
- 56.** A 50-pound bag of Turf Supreme fertilizer covers 8000 square feet. To the nearest whole number, what is the rate of coverage in square feet per pound?
- 57.** Mikisha traveled from Tampa to Miami, a distance of 280 miles, on one tank of gas. If her tank holds about 13 gallons of gas, what was her mile-per-gallon rate to the nearest whole number?
- 58.** The school magazine offers you \$2600 to write a 1500-word article dealing with spring-break activities. To the nearest cent, what is the rate per word?

>>> Skill Checker

Solve.

59. $18 = 3x$

60. $15 = 8x$

61. $6 \cdot 5 = 14x$

62. $7 \cdot 8 = 12x$

63. $6x = 9 \cdot 10$

64. $9x = 4 \cdot 6$

4.3 Proportions

▶ Objective

You should be able to:

- A > Write a proportion using the proper equation.
- B > Determine if two pairs of numbers are proportional.
- C > Solve a proportion.
- D > Solve applications involving the concepts studied.

▶ To Succeed, Review How To . . .

1. Reduce a fraction to lowest terms. (pp. 127–129)

▶ Getting Started

The length of each line is *proportional* to the one above it. More precisely, each line is 1.618034 . . . times as long as the previous one.

The *ratio* of your forearm length f to hand length h (measured from wrist to tip of middle finger) is written as $\frac{f}{h}$ and equal to the ratio 1.618034 . . .

We say that your forearm and hand are *proportional*. An equality of ratios is called a *proportion*.

Here, $\frac{f}{h} = \frac{1.618034 \dots}{1}$

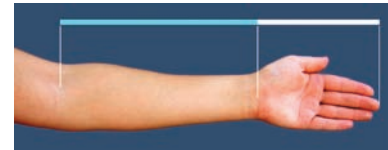

A > Writing Proportions

An equation that states that two ratios are equal is called a **proportion**. Thus, a proportion can be written as

WRITING PROPORTIONS

$$\frac{a}{b} = \frac{c}{d}$$

Read as “ a is to b as c is to d .”

Thus, the proportion 3 is to 4 as 6 is to 8 is written as

$$\frac{3}{4} = \frac{6}{8}$$

Similarly, the proportion 2 is to 9 as x is to 3 is written as

$$\frac{2}{9} = \frac{x}{3}$$

EXAMPLE 1 Writing proportions

Write each of the following proportions as an equation.

- a. 5 is to 10 as 1 is to 2
 b. 5 is to 6 as 15 is to x

SOLUTION 1

a. 5 is to 10 as 1 is to 2 is written as

$$\frac{5}{10} = \frac{1}{2}$$

b. 5 is to 6 as 15 is to x is written as

$$\frac{5}{6} = \frac{15}{x}$$

PROBLEM 1

Write each of the following proportions as an equation.

- a. 4 is to 12 as 1 is to 3
 b. 5 is to 8 as 10 is to y

We have already mentioned that the proportion a is to b as c is to d can be written as

$$\frac{a}{b} = \frac{c}{d}$$

which is an example of an **equation**. If we multiply both sides of this equation by bd , we obtain

$$(bd)\frac{a}{b} = (bd)\frac{c}{d}$$

or

$$(\cancel{bd})\frac{a}{\cancel{b}} = (\cancel{bd})\frac{c}{\cancel{d}}$$

That is,

$$ad = bc$$

We can remember this more easily by using the following rule:

THE CROSS-PRODUCT RULE (THEOREM)

$$\text{If } \frac{a}{b} = \frac{c}{d} \text{ then } ad = bc$$

Note: A theorem is an idea or rule that has been shown to be true, as we have done! That is, the **cross products** formed from the proportion are equal.

$$\frac{a}{b} \times \frac{c}{d} \rightarrow ad = bc$$

For example,

$$\frac{3}{4} = \frac{18}{24}$$

means

$$3 \cdot 24 = 4 \cdot 18$$

and

$$\frac{6}{7} = \frac{x}{14}$$

means

$$6 \cdot 14 = 7 \cdot x$$

This process is known as cross multiplying.

B > Determining if Numbers Are Proportional

We can use the cross product to find out if two pairs of numbers are proportional. Thus, to determine if the pair of numbers 10, 8 and 5, 4 are proportional, we write

$$\frac{10}{8} \stackrel{?}{=} \frac{5}{4} \quad 10 \cdot 4 \stackrel{?}{=} 8 \cdot 5$$

Since the cross products are equal ($10 \cdot 4 = 40$ and $8 \cdot 5 = 40$), the two pairs are proportional, that is,

$$\frac{10}{8} = \frac{5}{4}$$

Answers to PROBLEMS

1. a. $\frac{4}{12} = \frac{1}{3}$ b. $\frac{5}{8} = \frac{10}{y}$

EXAMPLE 2 Official width to length for the flag

There is a law stating that the ratio of width to length for the American flag should be 10 to 19. One of the largest flags measures 210 by 411 feet. Are the pairs of numbers 10, 19 and 210, 411 proportional?

**SOLUTION 2** We write

$$\frac{10}{19} \stackrel{?}{=} \frac{210}{411} \quad 10 \cdot 411 \stackrel{?}{=} 19 \cdot 210$$

But $10 \cdot 411 = 4110$ and $19 \cdot 210 = 3990$; thus, the cross products are not equal, so the two pairs are *not* proportional. The flag does not satisfy the 10 to 19 official flag ratio.

PROBLEM 2

The World's Largest Flag (Superflag) at the Hoover Dam (see photo) measures 255 feet by 505 feet. Do these measurements satisfy the 10 to 19 official flag ratio?

C > Solving Proportions

To solve proportions, we can use cross products. For example, the proportion $\frac{3}{2} = \frac{9}{x}$ can be solved as follows:

$$3x = 2 \cdot 9 \quad \text{Find the cross products.}$$

$$x = \frac{2 \cdot 9}{3} \quad \text{Divide both sides by 3.}$$

$$x = \frac{18}{3} \quad \text{Multiply 2 by 9.}$$

$$x = 6 \quad \text{Divide 18 by 3.}$$

You can check that 6 is the solution by replacing x with 6 in the original equation and then cross multiplying. We write

$$\frac{3}{2} = \frac{9}{6}$$

Since $3 \cdot 6 = 2 \cdot 9$ (both products are 18), the solution $x = 6$ is correct.

EXAMPLE 3 Solving proportions

Solve the proportions:

a. $\frac{6}{x} = \frac{2}{5}$

b. $\frac{x}{4} = \frac{9}{8}$

c. $\frac{5}{7} = \frac{x}{14}$

SOLUTION 3

a. $\frac{6}{x} = \frac{2}{5}$

$$6 \cdot 5 = 2 \cdot x \quad \text{Cross multiply.}$$

$$6 \cdot 5 = 2x$$

$$\frac{6 \cdot 5}{2} = x \quad \text{Divide both sides by 2 } \left(\frac{2x}{2} = x \right).$$

$$\frac{30}{2} = x \quad \text{Multiply 6 by 5.}$$

$$15 = x \quad \text{Divide 30 by 2 } \left(\frac{30}{2} = 15 \right).$$

The solution is $x = 15$.

PROBLEM 3

Solve the proportions:

a. $\frac{8}{x} = \frac{4}{5}$

b. $\frac{x}{6} = \frac{7}{8}$

c. $\frac{6}{7} = \frac{x}{14}$

Answers to PROBLEMS

2. No, $10 \cdot 505 \neq 19 \cdot 255$ 3. a. $x = 10$ b. $x = \frac{21}{4}$ c. $x = 12$

b. $\frac{x}{4} = \frac{9}{8}$

$8x = 4 \cdot 9$ Cross multiply.

$x = \frac{4 \cdot 9}{8}$ Divide both sides by 8 ($\frac{8x}{8} = x$).

$x = \frac{36}{8}$ Multiply 4 by 9.

$x = \frac{9}{2}$ Simplify by dividing the numerator and denominator by 4.

The solution is $x = \frac{9}{2}$.

c. $\frac{5}{7} = \frac{x}{14}$

$5 \cdot 14 = 7x$ Cross multiply.

$\frac{5 \cdot 14}{7} = x$ Divide both sides by 7 ($\frac{7x}{7} = x$).

$\frac{70}{7} = x$ Multiply 5 by 14.

$10 = x$ Divide 70 by 7 ($\frac{70}{7} = 10$).

The solution is $x = 10$.



D > Applications Involving Proportions

An important application of ratio and proportion is the creation of a scale drawing or model, a representation of an object that is to be drawn or built to actual size. The scale gives the relationship between the measurements of the drawing or model and the measurements of the real object. For example, Mini Me is Dr. Evil's clone and is said to be $\frac{1}{8}$ of Dr. Evil's size, so the scale is

1 inch is equivalent to 8 inches

How tall is Dr. Evil? We shall find out next.

EXAMPLE 4 Solving proportions

If Mini Me is 32 inches tall and $\frac{1}{8}$ of Dr. Evil's size, how tall is Dr. Evil?

SOLUTION 4 Since the scale is 1 inch (Mini Me) = 8 inches (Dr. Evil), and Mini Me is 32 inches tall, we write the proportion

$$\frac{\text{Mini Me}}{\text{Dr. Evil}} = \frac{1 \text{ inch}}{32 \text{ inches}} = \frac{8 \text{ inches}}{E}$$

$1 \cdot E = 32 \cdot 8$ Cross multiply.

$E = 256$ Multiply 32 by 8.

Thus, Dr. Evil has to be 256 inches tall ($21\frac{1}{3}$ ft!), which is clearly impossible.

PROBLEM 4

If Mini Me is 32 inches tall and $\frac{3}{7}$ of Dr. Evil's size, how tall is Dr. Evil?

How much air pollution does your car create? A car that gets 20 miles per gallon, driven 12,000 miles a year will use 600 gallons of gas and will produce $19 \times 600 = 11,400$ pounds of CO_2 . We find out how many trees are needed to absorb this CO_2 next.

Answers to PROBLEMS

4. $74\frac{2}{3}$ in.

GREEN MATH

EXAMPLE 5 Using trees to absorb CO₂

A tree absorbs 48 pounds of CO₂ per year. At that rate, how many trees are needed to absorb 11,400 pounds of CO₂?

SOLUTION 5

1 tree absorbs 48 pounds. The rate of absorption is $\frac{1}{48}$.

t trees need to absorb 11,400 pounds at a $\frac{t}{11,400}$ rate.

To maintain the rate, $\frac{t}{11,400} = \frac{1}{48}$

Cross multiplying $48t = 11,400$

Dividing by 48 $t = \frac{11,400}{48} = 237.5$ or 238

Thus, you need 238 trees to absorb the CO₂.

PROBLEM 5

If your car makes 25 miles per gallon, you only need 400 gallons of gas a year and you will then produce 19×400 or 7600 pounds of CO₂. Write the proportion you need to maintain the 1 tree rate of absorption and the number of trees needed to absorb the 7600 pounds of carbon.

Note that you can pollute less by driving fewer miles or having a more efficient car.

> Exercises 4.3



> Practice Problems > Self-Tests
> Media-rich eBooks > e-Professors > Videos

< A > Writing Proportions In Problems 1–8, write each proportion as an equation.

- | | | |
|--------------------------------|--------------------------------|-------------------------------|
| 1. 1 is to 4 as 5 is to 20 | 2. 5 is to 16 as 10 is to 32 | 3. a is to 3 as b is to 7 |
| 4. 7 is to a as 8 is to b | 5. a is to 6 as b is to 18 | 6. a is to b as 6 is to 8 |
| 7. 3 is to a as 12 is to b | 8. 9 is to 18 as a is to b | |

< B > Determining if Numbers are Proportional In Problems 9–18, determine if the pairs of numbers are proportional.

- | | | | |
|-----------------------|----------------------|---------------------|-----------------------|
| 9. 3, 4 and 5, 6 | 10. 6, 12 and 4, 8 | 11. 6, 9 and 8, 12 | 12. 7, 3 and 9, 4 |
| 13. 0.3, 5 and 3, 50 | 14. 0.9, 7 and 4, 30 | 15. 6, 1.5 and 8, 2 | 16. 3, 1.5 and 4, 0.2 |
| 17. 3, 1.2 and 5, 0.2 | 18. 5, 2.5 and 6, 3 | | |

< C > Solving Proportions In Problems 19–30, solve for x in the given proportion.

- | | | |
|--------------------------------|-------------------------------|--------------------------------|
| 19. 3 is to 4 as 6 is to x | 20. 5 is to 8 as 10 is to x | 21. 9 is to 10 as 18 is to x |
| 22. 5 is to 7 as x is to 21 | 23. 8 is to 5 as x is to 30 | 24. 4 is to 3 as x is to 12 |
| 25. 12 is to x as 4 is to 5 | 26. 18 is to x as 6 is to 5 | 27. 20 is to x as 4 is to 5 |
| 28. x is to 20 as 9 is to 10 | 29. x is to 21 as 2 is to 3 | 30. x is to 22 as 4 is to 2 |

Answers to PROBLEMS

5. $\frac{t}{7600} = \frac{1}{48}$; $158.\bar{3}$ or 158 trees

31. $\frac{x}{16} = \frac{3}{4}$

35. $\frac{8}{9} = \frac{x}{16}$

39. $\frac{3.5}{4} = \frac{x}{7}$

32. $\frac{x}{21} = \frac{5}{3}$

36. $\frac{7}{2} = \frac{x}{4}$

40. $\frac{4.5}{6} = \frac{x}{8}$

33. $\frac{15}{x} = \frac{5}{3}$

37. $\frac{14}{22} = \frac{7}{x}$

34. $\frac{14}{x} = \frac{7}{6}$

38. $\frac{18}{30} = \frac{6}{x}$

In Problems 41–50, write a proportion that could be used to solve for the variable, then solve.

41. 2 pairs of Bill Blass shorts for \$26
-
- 8 pairs of Bill Blass shorts for \$
- d

43. 5 Power Bar Energy Bites for \$4
-
- 8 Power Bar Energy Bites for \$
- x

45. \$4.38 for a 4-pound roast
-
- \$
- y
- for a 6-pound roast

47. \$9 for 3 pounds of top round steak
-
- \$
- z
- for 5 pounds of top round steak

49. \$6.95 for a 5-pack of Sanford Uniball pens
-
- \$5.56 for an
- x
- pack of Sanford Uniball pens

42. 2 pairs of Body Code shorts for \$25
-
- 5 pairs of Body Code shorts for \$
- d

44. 12-pack soda product for \$1.98
-
- 8-pack soda product for \$
- x

46. \$18 for 2 pounds of grouper fillet
-
- \$
- y
- for 3 pounds of grouper fillet

48. \$3.60 for 5 dozen Bic Round Stick pens
-
- \$2.16 for
- x
- dozen Bic Round Stick pens

50. \$2.88 for a 6-pack of Staples Outflow pens
-
- \$1.92 for an
- x
- pack of Staples Outflow pens

< D > Applications Involving Proportions

- 51.
- Ratio of cars to people in Bermuda*
- The ratio of cars to people in Bermuda is 340 to 1000. Write this ratio as a fraction in reduced form.

- 53.
- Business failures*
- In a recent year, the failure rate for businesses in the United States was 114 to 10,000. Write this ratio as a fraction in reduced form.

- 52.
- Ratio of cars to people in Haiti*
- The ratio of cars to people in Haiti is 4 to 1000. Write this ratio as a fraction in reduced form.

- 54.
- Business failures during the Depression*
- The highest failure rate for businesses in the United States occurred in 1932 during the Depression. The ratio was 154 to 10,000. Write this ratio as a fraction in reduced form.

>>> Applications: Green Math

In Exercises 55–58, assume a car is driven **15,000** miles per year making the miles per gallon (MPG) shown in the second column. Fill in the columns to find:

- The number of gallons used in a year when the car is driven 15,000 miles.
- The CO₂ produced at 19 pounds per gallon.
- A proportion to find t (trees needed at 48 lb per year) to absorb the CO₂ (See Example 5).
- The actual (rounded up) number of trees needed to absorb the CO₂.

MPG	a. Gallons/year	b. CO ₂ produced	c. Proportion to solve	d. t , trees needed to absorb
55. 15			$\frac{t}{19,000} = \frac{1}{48}$	
56. 20			$\frac{t}{14,250} = \frac{1}{48}$	
57. 25			$\frac{t}{11,400} = \frac{1}{48}$	
58. 30			$\frac{t}{9500} = \frac{1}{48}$	
59. <i>Property tax rate</i> The property tax in a certain state is \$9 for every \$1000 of assessed valuation (9 mills). What is the tax on a property assessed at \$40,000?				
60. <i>Property taxes</i> If the property tax rate is 12 mills (\$12 per thousand), what is the tax on a property assessed at \$45,000?				
61. <i>Scale airplane models</i> A plastic model of a 747 airplane is constructed to a scale of 1 to 144. If the wingspan of the model is 40 centimeters, how long is the actual wingspan on a 747 airplane? Note that 100 centimeters equal 1 meter.				
62. <i>Airplane models</i> If the length of the model airplane mentioned in Problem 71 is 48 centimeters, what is the actual length of a 747 airplane?				

63. *Ratio of declining to advancing stocks* On a certain day the ratio of stocks declining in price to those advancing in price was 5 to 2. If 300,000 stocks declined in price, how many advanced in price?

This graph will be used in Problems 65–66.

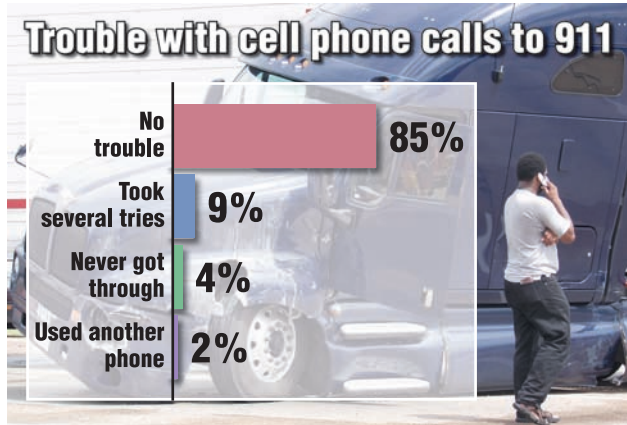

Source: Data from Anne R. Carey and Keith Carter, USA TODAY.

This graph will be used in Problem 67.

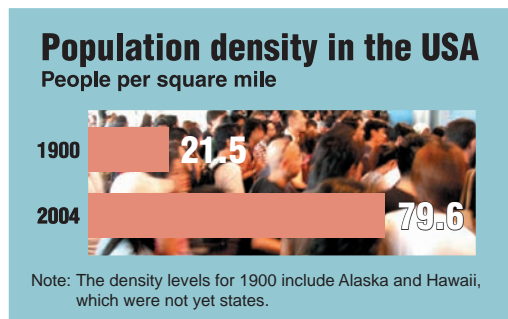

Source: Data from Anne R. Carey and Keith Carter, USA TODAY.

64. *Stocks* On a certain day the ratio of stocks advancing in price to those declining in price was 4 to 3. If 150,000 stocks advanced in price, how many declined in price?
65. *911 calls* As you can see from the graph, 85 out of 100 calls to 911 had no trouble.
- Write the ratio 85 out of 100 as a reduced fraction.
 - On a certain day, 500 calls were made to 911. How many calls to 911 would you expect to have no trouble? (See the graph.)
 - On a certain day, 102 callers reported some trouble calling 911. How many total calls were made to 911?
66. *911 calls* As you can see from the graph, 9 out of 100 calls to 911 took several tries.
- Write the ratio 9 out of 100 as a fraction.
 - On a certain day, 300 calls were made to 911. How many calls to 911 would you expect to have taken several tries?
 - On a certain day, 72 callers reported they had to make several tries to reach 911 (see the graph). How many total calls were made to 911?
67. *Population density of Lake Wobegon* In 2004, the population density of the United States reached 80 people per square mile (see graph). How many people would you expect around Lake Wobegon, Minnesota, an area of 50 square miles?
68. *Atlantis population density* According to Plato's description, the population of the lost city of Atlantis was between 6 and 10 million people. If the area of Atlantis was 86,400 square kilometers and the population is assumed to have been 8,640,000 inhabitants, what was the population density for Atlantis?
- Sources: atlantishistory.com; Eden—The Andrew Collins website.
70. *Population density in Monaco* Another densely populated city is Monaco with 31,980 inhabitants living on 1.95 square kilometers of land. What is the population density per square kilometer in Monaco?
71. *Aspect ratio (width to height)* The aspect ratio of a computer screen is 4:3.
- Write 4:3 as a fraction.
 - If the screen is 32 inches wide, what is the screen's height?
72. *Aspect ratio (width to height) of HDTV* The aspect ratio of a television set is 16:9.
- Write 16:9 as a fraction.
 - If the screen is 27 inches high, what is the screen's width?

Using Your Knowledge

Do you know what a **bounce rate** is? You should, if you have a website. Your **bounce rate** is a way to know if people are staying on your website or leaving right away. As the name implies, the **bounce rate** represents the percent of initial visitors to a site who “bounce” away to a different site rather than continue to other pages within the same site, sometimes within a specified period of time. It is defined by the formula

$$\text{Bounce rate} = \frac{\text{Number of visitors who visit a single page } (S)}{\text{Total Number of visits } (T)}$$

What does this rate mean? Here are some suggestions:

20% or under: Very good.

36%–50%: Cause for concern.

21–35%: Good.

Greater than 50%: Very worrying.

- 73.** If you have 73 visitors who visit a single page, how many total visits T do you need to get a 20% (Very good) bounce rate?
- 74.** If you have 140 visitors who visit a single page, how many total visits T do you need to get a 25% (Good) bounce rate?
- 75.** If the total number of visits T to your website is 520, how many of them visiting a single page will give you a 40% (Cause for concern) bounce rate?
- 76.** If the total number of visits to your website is 620, how many of them visiting a single page will give you a 60% (Very worrying) bounce rate?

>>> Write On

- 77.** Explain in your own words the difference between a ratio and a proportion.
- 78.** Explain in your own words the procedure you use to solve a proportion.
- 79.** Explain in your own words how proportions could be used in using a recipe to cook a favorite dish.
- 80.** Explain in your own words how you can tell if two ratios are proportional.

>>> Concept Checker

Fill in the blank(s) with the correct word(s), phrase, or mathematical statement.

- 81.** An **equation** stating that two ratios are **equal** is called a _____.
- 82.** If $\frac{a}{b} = \frac{c}{d}$ then $ad = bc$ is called the _____ rule.

proportion

quotient

ratio

cross product

>>> Mastery Test

- 83.** Write each proportion as an equation:
- a. 2 is to 5 as 4 is to 10
- b. 5 is to 8 as 15 is to x
- 85.** The ratio of width to length for an American flag is 10 to 19. A flag measuring 50 by 95 is made. Does this flag satisfy the 10 to 19 ratio?
- 87.** A worker can produce 10 parts in 3 hours. At that rate, how long would it take this worker to produce 30 parts?
- 84.** The ratio of bicycles to registered vehicles in Madison, Wisconsin, is 3 to 2. If there are 170,000 registered vehicles in Madison, how many bicycles do they have?
- 86.** Solve the proportion:
- a. $\frac{6}{x} = \frac{3}{2}$
- b. $\frac{3}{x} = \frac{5}{6}$
- c. $\frac{5}{7} = \frac{x}{14}$
- 88.** A statue of Professor Math is 30 inches tall. If the statue is $\frac{3}{7}$ as tall as Professor Math, how tall is Professor Math?

>>> Skill Checker

Solve.

- 89.** $3000 = 120p$
- 90.** $99 = 9t$
- 91.** $150 = 150c$
- 92.** $21,250 = 106.25n$

4.4

Problem Solving Involving Proportions

Objective

You should be able to:

A > Solve word problems involving proportions.

To Succeed, Review How To . . .

1. Reduce a fraction to lowest terms. (pp. 127–129)
2. Use the RSTUV method to solve word problems. (pp. 95, 186)
3. Solve a proportion. (pp. 284–285)

Getting Started

As we mentioned in the Getting Started of Section 4.3, the ratio of your forearm length f to your hand length h measured from the wrist to the tip of the middle finger,

satisfies the proportion $\frac{f}{h} = \frac{1.618034 \dots}{1}$.

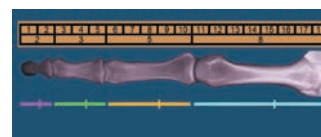

Now, suppose the length of your hand is 7 inches; what is the approximate length f of your forearm? You can find out by using the RSTUV procedure we have studied and solving the proportion $\frac{f}{h} = \frac{1.618034 \dots}{1}$. Your answer should be about 11.3 inches. Does this work all the time? Find out for yourself. Measure the length h of your hand and predict the length f of your forearm. Is the prediction close to the actual length? Is $\frac{f}{h}$ close to 1.618034 . . . ?

We shall practice using the RSTUV procedure in solving proportions next.

A > Word Problems Involving Proportions

EXAMPLE 1 Solving proportions: Rye grass coverage

A pound of rye grass seed covers 120 square feet of lawn. How many pounds are needed to seed a lawn measuring 60 feet by 50 feet (3000 square feet)?

SOLUTION 1 We use the RSTUV method discussed in Section 2.8.

1. **Read the problem.** Read the problem and decide what it asks for. (We want to know how many pounds of seed are needed.)
2. **Select the unknown.** Select a letter to represent the unknown. (Let p be the number of pounds needed.)
3. **Translate into an equation.** Translate the problem into an equation.

1 pound seeds 120 square feet

$\left(\frac{1 \text{ pound}}{120 \text{ square feet}}\right); p \text{ pounds seed } 3000 \text{ square feet } \left(\frac{p \text{ pounds}}{3000 \text{ square feet}}\right)$. Thus,

$$\frac{1}{120} = \frac{p}{3000}$$

PROBLEM 1

A pound of Bahia grass seed covers 100 square feet of lawn. How many pounds are needed to seed a lawn measuring 90 feet by 50 feet (4500 square feet)?

Answers to PROBLEMS

1. 45 pounds

4. Use the rules to solve. Use the rules studied to solve the equation.

$$1 \cdot 3000 = 120p \quad \text{Cross multiply.}$$

$$\frac{1 \cdot 3000}{120} = p \quad \text{Divide both sides by 120.}$$

$$25 = p \quad \text{Simplify.}$$

Thus, 25 pounds are needed.

5. Verify the answer. Verify your answer. If we substitute 25 for p in step 3, we have:

$$\frac{1}{120} = \frac{25}{3000}$$

Cross multiplying, $1 \cdot 3000 = 120 \cdot 25$, which is a true statement. Thus, our answer is correct.

To make the work easier, we will shorten some of the steps in Examples 2 to 4.

EXAMPLE 2 Solving proportions: Computer trouble

Have you had trouble with a computer lately? A recent study indicated that 2 out of 5 families run into trouble with a computer in the course of a year. If 3000 families were surveyed, how many families would have run into trouble with the computer?

SOLUTION 2

- 1. Read.** Read the problem.
- 2. Select unknown.** Select f to represent the number of families that ran into trouble.
- 3. Translate.** Translate: Note that 3000 is the *total* number of families surveyed. Thus

$$\frac{2}{5} = \frac{f}{3000}$$

- 4. Use cross products.** Use cross products:

$$2 \cdot 3000 = 5f$$

$$\frac{2 \cdot 3000}{5} = f \quad \text{Divide by 5.}$$

$$\frac{6000}{5} = f \quad \text{Multiply.}$$

$$1200 = f \quad \text{Divide.}$$

That is, 1200 families ran into trouble.

- 5. Verify.** Verification is left for you.

PROBLEM 2

If a study revealed that 2 out of 5 families run into trouble with a computer and it is known that 300 families had trouble with the computer, how many families were surveyed?

EXAMPLE 3 Solving proportions: Protein in diet

Do you have enough protein in your diet? Females are supposed to have 44 grams every day. If 2 tablespoons of peanut butter provide 8 grams of protein, how many tablespoons does a female need to have 44 grams of protein?

SOLUTION 3

- 1. Read.** Read the problem.
- 2. Select unknown.** Select t to be the number of tablespoons needed.
- 3. Translate.** Translate: 2 tablespoons provide 8 grams $\left(\frac{2 \text{ tablespoons}}{8 \text{ grams}}\right)$; t tablespoons provide 44 grams $\left(\frac{t \text{ tablespoons}}{44 \text{ grams}}\right)$.

$$\frac{2}{8} = \frac{t}{44}$$

PROBLEM 3

Males need 56 grams of protein every day. If 2 tablespoons of peanut butter provide 8 grams of protein, how many tablespoons does a male need to have 56 grams of protein?

(continued)

Answers to PROBLEMS

2. 750 3. 14 tablespoons

4. Use cross products. Use cross products:

$$2 \cdot 44 = 8t$$

$$\frac{2 \cdot 44}{8} = t \quad \text{Divide both sides by 8.}$$

$$\frac{88}{8} = t \quad \text{Multiply.}$$

$$11 = t \quad \text{Divide.}$$

Thus, 11 tablespoons of peanut butter are needed to obtain 44 grams of protein.

5. Verify. Verification is left for you.

The peanut butter in Example 4 has a **carbon footprint** (carbon emissions associated with their production and transportation). What if all food labels also contained information about the associated carbon emissions? Example 4 shows a sample label for peanut butter.

GREEN MATH

EXAMPLE 4 Nutrition facts and carbon footprint

It takes 118 grams of CO_2 emissions to produce one serving (2 tablespoons) of peanut butter. At this rate, how many grams of CO_2 are needed to produce 7 tablespoons ($\frac{1}{4}$ jar)?

SOLUTION 4

- 1. Read.** Read the problem.
- 2. Select unknown.** Let g be the number of grams needed to produce 7 tablespoons.
- 3. Translate.**
118 grams are needed to produce 2 tablespoons: $(\frac{118 \text{ grams}}{2 \text{ tablespoons}})$.
 g grams are needed to produce 7 tablespoons: $(\frac{g \text{ grams}}{7 \text{ tablespoons}})$.

$$\text{Thus, } \frac{118 \text{ grams}}{2 \text{ tablespoons}} = \frac{g \text{ grams}}{7 \text{ tablespoons}} \text{ or } \frac{118}{2} = \frac{g}{7}$$

- 4. Use cross products.** $7 \cdot 118 = 2g$
$$\frac{7 \cdot 118}{2} = g \quad \text{Divide both sides by 2.}$$

$$\frac{826}{2} = g \quad \text{Multiply 7 by 118.}$$

$$413 = g \quad \text{Divide by 2.}$$

Thus, it takes 413 grams of CO_2 to produce 7 tablespoons ($\frac{1}{4}$ jar) of peanut butter.

5. Verify. The verification is left for you.

You may have noticed that the total carbon emissions needed to produce the whole jar of peanut butter is 1648 grams (Look at the label!), so to make $\frac{1}{4}$ of the jar it would take $\frac{1}{4}$ of 1648 or 412 grams. We have no way of verifying that the figures in the label are actually consistent!

PROBLEM 4

Using the same rate as in the example (118 grams to make 2 tablespoons), how many grams of CO_2 are needed to make 14 tablespoons ($\frac{1}{2}$ jar) of the peanut butter?

Nutrition Facts

Peanut Butter

Serving Size: 2 tablespoons
Servings Per Container: about 14

Amount Per Serving	
Calories 200	Calories from fat 10
% Daily Value	
Total Fat 16 g	25%
Saturated Fat 2.5 g	12%
Trans Fat 0 g	0%
Cholesterol 0 mg	0%
Sodium 120 mg	5%
Total Carbohydrates 6 g	2%
Dietary Fiber 2 g	9%
Sugars 1 g	
Protein 8 g	



Carbon Footprint

Per Serving: 118g CO_2e
Total Carbon: 1648g CO_2e

Primary location of origin:
Orrville, Ohio

Method of transportation:
Train/Truck



Note: Carbon rating ranges from 1 to 10, with lower numbers being more climate friendly.

Carbon dioxide equivalent (CO_2e) accounts for carbon dioxide and other greenhouse gases.

Source: <http://tinyurl.com/dg5qd4>.

Answers to PROBLEMS

4. 826 grams

Proportions are used in medicine for calculating dosages. Suppose you know the adult dose for a certain medicine. How can you find the dose suitable for children? “The only rule based on scientific principles and the one which should be used” is Clark’s Rule.

The rule states that the ratio of the weight of the child W_c to the average weight of an adult W_a is proportional to the children’s dose c divided by the adult dose a , that is,

$$\text{Clark's Rule} \quad \frac{W_c}{W_a} = \frac{c}{a}$$

Source: Texas Health Science Technology Education.

We use this rule in Example 5.

EXAMPLE 5 Solving proportions: Children’s dose of antibiotics

The recommended dose of antibiotics for a 150-pound adult is 3 pills. What is the equivalent dose suitable for a child weighing 50 pounds?

SOLUTION 5 You can reason like this:

150 pound adult: 3 pills

50 pound ($\frac{1}{3}$ weight): $\frac{1}{3}$ (3 pills) = 1 pill

But can you prove it? Let’s see.

- 1. Read the problem.** Read the problem. We have to use Clark’s Rule.
- 2. Select the unknown.** The unknown is the dose of pills for a child; call it c .
- 3. Translate the problem into an equation or inequality.** According to Clark’s Rule,

$$\frac{W_c}{W_a} = \frac{c}{a}$$

W_c (the weight of the child) = 50

W_a (the weight of the adult) = 150

a (the adult dose) = 3 pills

- 4. Use the rules we have studied to solve the equation.** Substitute these values into the equation:

$$\begin{aligned} \frac{50}{150} &= \frac{c}{3} \\ 3 \cdot 50 &= 150c && \text{Cross multiply.} \\ 150 &= 150c && \text{Multiply 3 by 50.} \\ 1 &= c && \text{Divide by 150.} \end{aligned}$$

Thus, the equivalent dose of antibiotics for a 50-pound child is 1 pill.

- 5. Verify the answer.** To verify the answer, note that the ratio of the weight of the child to the weight of the adult is $\frac{50}{150}$ or $\frac{1}{3}$. In the same manner, the ratio of pills taken by the child to pills taken by the adult is 1 to 3 or $\frac{1}{3}$.

PROBLEM 5

What is the dose for a child weighing 75 pounds?

Finally, we shall consider strength—not your algebra strength, but the strength of different animals! Elephants can carry up to 25% of their own weight on their backs, camels about 20%, and leaf-cutting ants about 3 times their own weight, but rhinoceros beetles can carry about 850 times their body weight. How strong is that? We shall see in Example 6.

Source: Data from edHelper.com.



Answers to PROBLEMS

5. $1\frac{1}{2} = 1.5$ pills

EXAMPLE 6 Solving proportions: Rhinoceros beetle

A rhinoceros beetle weighs 30 grams and can carry 850 times its body weight, that is, 25,500 grams. If a person could carry proportionally as much as the rhinoceros beetle, how much could a 60-kilogram (kg) student carry?

SOLUTION 6

- 1. Read the problem.** We want to find how much a 60-kilogram student can carry.
- 2. Select the unknown.** Let W be the weight of the student. The ratio of body weight to carrying weight for the beetle is $\frac{30}{25,500}$. For the student the ratio is $\frac{60}{W}$.
- 3. Translate the problem into an equation or inequality.** We want the weights to be proportional, so

$$\frac{30}{25,500} = \frac{60}{W}$$

- 4. Use the rules we have studied to solve the equation.**

Cross multiply: $30W = 60 \cdot 25,500$

Divide by 30: $W = 51,000$ kg

Since 1 kilogram is about 2.2 pounds, the 51,000 kilograms represents more than 100,000 pounds! Strong indeed.

- 5. Verify the answer.** If students could carry 850 times their weight (like the beetle), a 60-kilogram student could carry $850 \cdot 60 = 51,000$ kg as stated.

PROBLEM 6

Proportionally, how much could a 90 kilogram football player carry?

Exercises 4.4

> Practice Problems > Self-Tests
> Media-rich eBooks > e-Professors > Videos

< A > Word Problems Involving Proportions In Problems 1–30, use the RSTUV procedure to solve.

- 1. Lawn coverage** One pound of weed and feed covers 200 square feet. How many pounds are needed to cover a lawn measuring 60 feet by 50 feet (3000 square feet)?
- 2. Fertilizing the lawn** One pound of fertilizer covers 250 square feet. How many pounds are needed to fertilize a lawn measuring 70 feet by 50 feet (3500 square feet)?
- 3. Advancing stocks** On a recent day, 2 out of 5 stocks in the New York Stock Exchange (NYSE) advanced in price. If 1900 issues were traded, how many advanced in price?
- 4. Declining stocks** On a recent day, 3 out of 5 stocks in the NYSE declined in price. If 1500 issues were traded, how many declined in price?
- 5. Male RDA of protein** The recommended daily allowance (RDA) of protein for males in the 15–18 age range is 56 grams per day. Two ounces of cheddar cheese contain 14 grams of protein. How many ounces of cheddar cheese are needed to provide 56 grams of protein?
- 6. Protein RDA for children** The RDA of protein for children 7–10 is 30 grams per day. One cup of whole milk contains 8 grams of protein. How many cups of milk are needed to provide the 30 grams RDA?
- 7. Buying stocks** Fifty shares of Titan Corp. stock cost \$112.50. How many shares can be bought with \$562.50?
- 8. Buying Mega stocks** Three shares of Mega stock cost \$144.75. How many shares can be bought with \$1544?
- 9. Showering for sleep** It has been estimated that a 10-minute shower is worth $1\frac{1}{2}$ hours of sleep. Using this scale, how long do you have to shower to get 6 hours of sleep?
- 10. Mail** It has been estimated that 3 out of 4 pieces of mailed advertising are opened and glanced at. Using this scale, how many pieces of advertising should you send if you want 900 persons to open and glance at your ad?
- 11. Getting the votes** It has been estimated that for every 10 volunteers working in a political campaign, the candidate gets 100 votes on election day. A candidate has 770 volunteers. How many votes can this candidate expect to get on election day?
- 12. Waiter, Waiter!** To make sure your dinner party runs smoothly, you will need 3 waiters for every 20 guests. How many waiters should you hire for a party of 80?
- 13. Drinking water** You can maintain your body fluid level by drinking four gulps of water every 20 minutes during prolonged exercise. How many gulps do you need for a 2-hour workout?
- 14. Pages in a 2000-word document** A full, double-spaced typewritten page will have about 250 words on it if typed using a pica typefont. How many pages would there be in a double-spaced 2000-word paper typed using a pica typefont?

Answers to PROBLEMS

6. 76,500 kg

- 15. Pages in a 6600-word paper** One full, double-spaced type-written page will have about 330 words on it if typed using an elite typefont. How many pages would there be in a double-spaced 6600-word paper typed using an elite typefont?
- 17. Interest rates** A 1-point increase in interest rates adds \$2.3 billion a year to federal spending. If interest rates went up 2.5 points, how much would that add to federal spending?
- 19. Growing mesquite grass** It takes 1725 pounds of water to grow 1 pound of mesquite grass (used for cattle feeding). How many pounds of water are needed to grow a 50-pound bale of mesquite grass?
- 16. Inflation and spending** A writer for the *New York Times* estimates that a 1-point increase in the inflation rate will add \$1.3 billion to federal spending in the first year. If the inflation rate increases 3.5 points, how much money will be added to federal spending in the first year?
- 18. Windows needed for the superinsulated house** A superinsulated home must have 12 square feet of windows for every 100 square feet of floor space. How many square feet of windows are needed for a superinsulated 1700-square-foot home?
- 20. New plant and equipment spending** U.S. manufacturers spent \$150 billion on new plants and equipment but \$200 billion on mergers and acquisitions. Kohlberg, Kravis, and Roberts acquired Nabisco for about \$20 billion. How many billions should they expect to spend on new plants and equipment?

The serving size for each of the pizzas shown is $\frac{1}{4}$ of the pizza. Which one do you think has the least fat?



Source: California Project Lean.

- 21. Pizza** Charley's pizza has 13 grams of fat per serving. How many grams of fat are in $\frac{3}{4}$ of the pizza?
- 23. Pizza** Garden Delight pizza has 7 grams of fat per serving. How many grams of fat are in the whole pizza?
- 25. Global Internet population** In 2009, 250 million people in the United States were part of the global Internet population. If the 250 million people represent $\frac{1}{7}$ of the global Internet population, how many people are there in the global Internet population?
- 27. Making nail polish remover** The formula for an acetone (nail polish remover) molecule is C_3H_6O . This means that for every 3 carbon (C) atoms, there are 6 hydrogen (H) atoms and one oxygen (O) atom in the molecule. How many carbon atoms must combine with 720 hydrogen atoms to form acetone molecules?
- 29. Map distances to scale** The scale in a map is 1 inch = 20 miles. What is the actual distance between two towns that are 3.5 inches apart on the map?
- 22. Pizza** The Peppy pepperoni pizza has 21 grams of fat per serving. How many grams of fat are in $\frac{1}{2}$ of the pizza?
- 24. Overweight Americans** 54 out of 100 Americans consider themselves overweight. If there are 290 million Americans, how many consider themselves overweight?
- 26. Leaf-cutting ant loads** A leaf-cutting ant weighing 1.5 grams can carry a leaf weighing 4.5 grams. If a person could proportionally carry as much weight, how much could a 60-kilogram student carry?
- 28. Polish remover** Referring to Problem 27, how many oxygen atoms are needed to combine with 660 hydrogen atoms to form acetone molecules?
- 30. Map spacing** Two towns are 300 miles apart. If the scale on the map is 1 inch = 20 miles, how far apart are the towns on the map?

Applications: Green Math

Have you ever heard of Tesco, a mega supermarket in England? They use a carbon footprint on their labels. What is the exact amount of greenhouse gas emissions generated in the production of a single roll of toilet paper? You will find out in a moment.

- 31. Sheets in recycled-content toilet paper roll** When making one "sheet" of Tesco recycled-content toilet paper, 1.1 grams of CO_2 are produced as a by-product. If 220 grams of CO_2 result when producing the whole roll of toilet paper, how many sheets are in a roll?
- 32. Sheets in nonrecycled-content toilet paper roll** When making one "sheet" of Tesco's nonrecycled-content toilet paper roll, 1.8 grams of CO_2 are produced as a by-product. If 360 grams of CO_2 result when producing the whole roll of toilet paper, how many sheets are in a roll?



33. *CO₂ by-products from juice production* 360 grams of CO₂ by-product result when producing 250 milliliters (8.5 ounces) of juice. How many grams of CO₂ will result when producing 4 ounces of juice? Answer to the nearest gram.
34. *Carbon footprint of one carton of orange juice* How many sheets of recycled-content toilet paper (1.1 grams per sheet) are needed to match the carbon footprint (360 grams) of one carton of orange juice? Answer to the nearest sheet.



>>> Using Your Knowledge

Wildlife Populations Have you seen scientists or bird lovers banding or tagging animals? This procedure is used to estimate the size of wildlife populations. Here is how it works. First, a number of animals are captured, tagged, and released. Later, a different group is captured, and the ratio of tagged animals to the number of animals captured is determined. From this ratio the size of the population can be estimated. For example, a research team tagged 60 birds for identification. Later, they captured 240 birds and found 15 tagged. Can they estimate the number n of birds in the population? They know that the ratio of tagged birds to the total number of birds is 15 to 240. They also know that this ratio was 60 to n . Thus,

$$\frac{\text{Number tagged}}{\text{Total number}} = \frac{\text{Number tagged}}{\text{Total number}}$$

$$\frac{15}{240} = \frac{60}{n}$$

Solving the proportion they obtain $n = 960$.

Follow this procedure to solve Problems 35 and 36.

35. Researchers in the Vienna Woods tagged 300 birds. In a later sample they found that 12 out of 980 birds were tagged. About how many birds were there in the Vienna Woods?
36. In Muddy Lake 600 fish were tagged. Later, 12 out of 480 fish were found to be tagged. About how many fish were in Muddy Lake?

>>> Write On

37. We solved proportions such as $\frac{x}{2} = \frac{1}{2}$ by the method of cross products. Can you solve $\frac{x}{2} = \frac{1}{2} + 1$ by using cross products? Explain.
38. Clark's Rule helps you to find the suitable child's dose for a medicine based on the adult dose. Does the rule tell you how to administer the medicine? Explain.

>>> Concept Checker

Fill in the blank(s) with the correct word(s), phrase, or mathematical statement.

39. When using the **RSTUV** procedure, step **T** means to _____ the problem.

guessing **cross product**

40. To solve a **proportion** we use the _____ rule.

transpose **algebra**

translate

>>> Mastery Test

41. According to Clark's Rule $\frac{W_c}{W_a} = \frac{c}{a}$, Where W_c is the weight of the child, W_a is the weight of the adult, a is the adult dose, and c is the child's dose. If the adult dose (150-pound person) of cough syrup is 6 teaspoons daily, what is a 50-pound child's dose?
42. A leaf-cutting ant weighing 1.5 grams can carry a leaf weighing 3 grams. If a person could proportionally carry as much weight, how much could a 70-kilogram student carry?
43. *Stocks* Fifty shares of Mega stock cost \$212.50. How many shares can you buy with \$850?
44. *Protein* If a 120-pound woman needs 50 grams of protein a day and a 4-ounce serving of chicken provides 30 grams of protein, how many ounces of chicken are needed to provide the required 50 grams of protein?
45. *College Algebra students* Two out of three students at a college passed College Algebra with a C or better. If 600 students were taking College Algebra, how many passed with a C or better?
46. *Rye seed* Perennial rye seed covers 250 square feet per pound. How many pounds are needed to seed a lawn measuring 50 feet by 100 feet (5000 square feet)?

>>> Skill Checker

Round 245.92

47. to the nearest tenth.
48. to the nearest unit.
49. to the nearest ten.
50. to the nearest hundred.

> Collaborative Learning

There is a relationship between the numbers in the Fibonacci sequence, the so-called Golden Section numbers, and $\frac{1}{89}$. Here is some information you will need to do this activity:

The Fibonacci numbers are: 1, 1, 2, 3, 5, 8, 13, . . .

The Golden Section numbers are: 0.6180339887 . . . 1.6180339887 . . . and $\frac{1}{89} = 0.01123595 . . .$

Form three groups of students.

Group 1. Find the ratio of numbers *preceding* each other in the Fibonacci sequence and write them as decimals to six places. Here are some:

$$\frac{1}{1} = 1.000000 \qquad \frac{3}{2} = 1.500000$$

$$\frac{2}{1} = 2.000000 \qquad \frac{5}{3} = 1.666666$$

What number is the pattern approaching?

Group 2. Find the ratio of numbers *following* each other in the Fibonacci sequence and write them as decimals to six places. Here are some:

$$\frac{1}{1} = 1.000000 \qquad \frac{2}{3} = 0.666666$$

$$\frac{1}{2} = 0.500000 \qquad \frac{3}{5} = 0.600000$$

What number is the pattern approaching?

Group 3. Arrange the numbers in the Fibonacci sequence 1, 1, 2, 3, 5, . . . as decimals like this:

$$0.01 \quad 0.001 \quad 0.0002 \quad 0.00003 \quad 0.000005$$

Find the next 5 terms and the sum of the 10 terms obtained. What number is the pattern approaching? Pick any *four* consecutive Fibonacci numbers, say, **1 2 3 5**

Group 1. Find the product of the *first* and *last* numbers, $1 \times 5 = \mathbf{5}$ this time.

Group 2. Find *twice* the product of the two middle numbers, $2 \times (2 \times 3) = \mathbf{12}$ this time.

Group 3. Get the answers from Groups 1 and 2 and square them.

$$5^2 = 25 \quad \text{and} \quad 12^2 = 144$$

ALL GROUPS: Make a conjecture about writing the sum of the two answers as a number squared. Repeat the process with four different consecutive Fibonacci numbers. Does the conjecture still work? ▮

Research Questions

1. The *Human Side of Mathematics* at the beginning of this chapter mentions several names for Leonardo Fibonacci. Find at least two more names used for Fibonacci.
2. Find at least two different interpretations of the name Fibonacci.
3. Find the meaning of the word *bigollo* in Italian.
4. The *Human Side of Mathematics* mentions the *Liber Abaci*, a book written by Fibonacci. Find the titles of three other books he wrote and describe their contents.
5. The *Human Side of Mathematics* mentions “the rabbit problem.” State the problem and indicate how the Fibonacci sequence relates to it.
6. There are at least five more famous problems by Fibonacci in the *Liber Abaci*. State three of them.
7. In what year did Fibonacci die?
8. There is a set of numbers called the Golden Section numbers associated with the Fibonacci sequence. What are these numbers, and how are they associated with the Fibonacci sequence?

Summary Chapter 4

Section	Item	Meaning	Example
4.1A	Ratio	A comparison of two numbers or quantities measured with the same units	The ratio 2 to 3 (also written as 2:3 or $\frac{2}{3}$)
4.2	Rates	A comparison of two numbers or quantities often measured with different units A ratio used to compare unlike quantities	$\frac{21 \text{ miles}}{3 \text{ gallons}}$
4.2B	Unit rate	A rate in which the denominator is 1	$\frac{28 \text{ miles}}{1 \text{ gallon}}$
4.3A	Proportion	An equation stating that two ratios are equal	$\frac{a}{b} = \frac{c}{d}$ is a proportion.
4.4A	RSTUV	Method used to solve word problems (R ead, S elect a variable, T ranslate, U se the rules studied to solve, V erify the answer)	

Review Exercises Chapter 4

(If you need help with these exercises, look in the section indicated in brackets.)

- 1.** **<4.1A>** Express each ratio as a fraction in lowest terms:

 - 1 to 10
 - 2 to 10
 - 3 to 10
 - 4 to 10
 - 5 to 10
- 3.** **<4.1A>** The approximate ratio of circumference (distance around) to diameter (distance across the top) of a soda can is given. Write this ratio as a fraction in reduced form.

 - 14.52 inches to 4.62 inches
 - 14.58 inches to 4.64 inches
 - 14.60 inches to 4.65 inches
 - 14.64 inches to 4.66 inches
 - 14.68 inches to 4.67 inches
- 5.** **<4.2A>** A famous writer was paid \$12,000 for an essay. What was her rate per word, if the essay had:

a. 2000 words?	b. 3000 words?
c. 4000 words?	d. 6000 words?
e. 8000 words?	
- 7.** **<4.2A>** A bag of fertilizer covers 5000 square feet of lawn. To the nearest whole number, what is the rate of coverage (in square feet per pound) if the bag contains:

 - 20 pounds of fertilizer?
 - 22 pounds of fertilizer?
 - 24 pounds of fertilizer?
 - 25 pounds of fertilizer?
 - 50 pounds of fertilizer?
- 9.** **<4.2B>** A 12-ounce bottle of generic popcorn oil sells for \$1.39. Which is the better buy if the brand X popcorn oil contains 24 ounces and costs:

a. \$2.75?	b. \$2.76?
c. \$2.77?	d. \$2.74?
e. \$2.79?	
- 2.** **<4.1A>** The ratio of cars to people for different countries is given. Write each ratio as a fraction in reduced form.

 - Canada, 425 cars per 1000 persons
 - Belgium, 325 cars per 1000 persons
 - Austria, 300 cars per 1000 persons
 - Cyprus, 150 cars per 1000 persons
 - Taiwan, 40 cars per 1000 persons
- 4.** **<4.1A>** The male-to-female ratio for different countries is given. Write this ratio as a fraction in reduced form.

 - Kuwait, 58 to 42
 - Guam, 55 to 45
 - Pakistan, 52 to 48
 - Malaysia, 48 to 52
 - Grenada, 46 to 54
- 6.** **<4.2A>** A student took a 400-mile car trip. To the nearest whole number, what was the miles-per-gallon rate if the amount of gas used was:

a. 18 gallons?	b. 19 gallons?
c. 20 gallons?	d. 21 gallons?
e. 22 gallons?	
- 8.** **<4.2B>** A jar of popcorn costs \$2.39. To the nearest cent, what is the unit price in cents per ounce if the jar contains:

a. 24 ounces?	b. 16 ounces?
c. 32 ounces?	d. 40 ounces?
e. 48 ounces?	
- 10.** **<4.3A>** Write the following proportions as equations.

 - 3 is to 7 as 6 is to x
 - 4 is to 7 as 12 is to x
 - 5 is to 7 as x is to 21
 - 6 is to 7 as 33 is to x
 - 7 is to 35 as 5 is to x

- 11. <4.3B>** Determine if the following pairs of numbers are proportional.
- 2, 3 and 4, 5
 - 8, 10 and 4, 5
 - 5, 6 and 12, 15
 - 12, 18 and 2, 3
 - 9, 12 and 3, 4
- 12. <4.3C>** Solve the proportion:
- $\frac{x}{4} = \frac{1}{2}$
 - $\frac{x}{6} = \frac{1}{2}$
 - $\frac{x}{8} = \frac{1}{2}$
 - $\frac{x}{10} = \frac{1}{2}$
 - $\frac{x}{12} = \frac{1}{2}$
- 13. <4.3C>** Solve the proportion:
- $\frac{2}{x} = \frac{2}{5}$
 - $\frac{4}{x} = \frac{2}{5}$
 - $\frac{6}{x} = \frac{2}{5}$
 - $\frac{10}{x} = \frac{2}{5}$
 - $\frac{12}{x} = \frac{2}{5}$
- 14. <4.3C>** Solve the proportion:
- $\frac{x}{4} = \frac{9}{2}$
 - $\frac{x}{4} = \frac{9}{12}$
 - $\frac{x}{4} = \frac{9}{18}$
 - $\frac{x}{4} = \frac{9}{36}$
 - $\frac{x}{4} = \frac{9}{6}$
- 15. <4.3C>** Solve the proportion:
- $\frac{5}{7} = \frac{x}{7}$
 - $\frac{5}{7} = \frac{x}{14}$
 - $\frac{5}{7} = \frac{x}{28}$
 - $\frac{5}{7} = \frac{x}{35}$
 - $\frac{5}{7} = \frac{x}{42}$
- 16. <4.3D>** A worker in an assembly line takes 3 hours to produce 27 parts. At that rate how many parts can she produce in:
- 1 hour?
 - 2 hours?
 - 4 hours?
 - 5 hours?
 - 6 hours?
- 17. <4.4A>** A pound of grass seed covers 120 square feet of lawn. Find how many pounds are needed to seed a lawn with the following measurements:
- 60 feet by 30 feet (1800 square feet).
 - 70 feet by 30 feet (2100 square feet).
 - 90 feet by 24 feet (2160 square feet).
 - 60 feet by 45 feet (2700 square feet).
 - 50 feet by 60 feet (3000 square feet).
- 18. <4.4A>** A survey indicated that three out of five doctors used brand X aspirin. Find how many used brand X if:
- 3000 doctors were surveyed.
 - 4000 doctors were surveyed.
 - 5000 doctors were surveyed.
 - 6000 doctors were surveyed.
 - 8000 doctors were surveyed.
- 19. <4.4A>** The RDA of protein for males is 56 grams per day. Find how many ounces of a certain product are needed to provide the 56 grams of protein if it is known that
- 3 ounces of the product provide 8 grams of protein.
 - 4 ounces of the product provide 8 grams of protein.
 - 5 ounces of the product provide 8 grams of protein.
 - 6 ounces of the product provide 8 grams of protein.
 - 7 ounces of the product provide 8 grams of protein.
- 20. <4.4A>** The cost of 50 shares of Fly-by-Night Airline is \$87.50. Find how many shares you can buy with:
- \$350.
 - \$700.
 - \$612.50.
 - \$787.50.
 - \$1050.

Practice Test Chapter 4

(Answers on page 302)

Visit www.mhhe.com/bello to view helpful videos that provide step-by-step solutions to several of the problems below.

1. Express each ratio as a fraction in lowest terms:
a. 2 to 7 b. 3 to 18 c. 10 to 58
3. The approximate ratio of circumference (distance around) to diameter (distance across the top) of a soda can is 15.55 inches to 4.95 inches. Write this ratio as a fraction in reduced form.
5. A famous writer was paid \$12,000 for a 5000-word article. Find the rate per word.
7. An 18-pound bag of lawn food covers 3000 square feet of lawn. To the nearest whole number, what is the rate of coverage in square feet per pound?
9. A 12-ounce bottle of gourmet popcorn oil sells for \$1.39. The 24-ounce brand X bottle costs \$2.77. Which is the better buy?
11. There is a law stating that the ratio of width to length for the American flag should be 10 to 19. A flag measured 40 by 78 feet. Are the pairs of numbers 10, 19 and 40, 78 proportional?
13. Solve the proportion $\frac{6}{x} = \frac{2}{5}$.
15. Solve the proportion $\frac{5}{7} = \frac{x}{28}$.
17. A pound of grass seed covers 120 square feet of lawn. How many pounds are needed to seed a lawn measuring 60 feet by 40 feet (2400 square feet)?
19. The RDA of protein for males is 56 grams per day. Two ounces of a certain product provide 4 grams of protein. How many ounces of the product are needed to provide 56 grams of protein?
2. The ratio of cars to people in Australia is 485 per 1000. Write this ratio as a fraction in reduced form.
4. The male-to-female ratio in India is 54 to 46. Write this ratio as a fraction in reduced form.
6. A student traveled 300 miles on 17 gallons of gas. What was the miles-per-gallon rate? (Round the answer to the nearest whole number.)
8. A 30-ounce jar of popcorn costs \$2.49. What is the unit price in cents per ounce? (Answer to the nearest cent.)
10. Write the following proportions.
a. 2 is to 7 as 6 is to 21
b. 5 is to 7 as 15 is to x
12. Solve the proportion $\frac{x}{2} = \frac{5}{20}$.
14. Solve the proportion $\frac{x}{8} = \frac{9}{12}$.
16. A worker in an assembly line takes 3 hours to produce 26 parts. At that rate how many parts can she produce in 9 hours?
18. A survey indicated that 3 out of 7 doctors used brand X aspirin. If 2100 doctors were surveyed, how many used brand X?
20. The cost of 50 shares of Fly-by-Night Airline is \$87.50. How many shares can you buy with \$875?

› Answers to Practice Test Chapter 4

Answer	If You Missed		Review	
	Question	Section	Examples	Page
1. a. $\frac{2}{7}$ b. $\frac{1}{6}$ c. $\frac{5}{29}$	1	4.1	1	269
2. $\frac{97}{200}$	2	4.1	2	269
3. $\frac{311}{99}$	3	4.1	3	269–270
4. $\frac{27}{23}$	4	4.1	4	270
5. \$2.40	5	4.2	1	275
6. 18	6	4.2	2	275
7. 167	7	4.2	3	275
8. 8¢	8	4.2	6	277
9. Brand X, the 24-oz bottle	9	4.2	7	277
10. a. $\frac{2}{7} = \frac{6}{21}$ b. $\frac{5}{7} = \frac{15}{x}$	10	4.3	1	283
11. No	11	4.3	2	284
12. $x = \frac{1}{2}$	12	4.3	3b	285
13. $x = 15$	13	4.3	3a	284
14. $x = 6$	14	4.3	3b	285
15. $x = 20$	15	4.3	3c	285
16. 78	16	4.3	4, 5	285–286
17. 20 lb	17	4.4	1	290–291
18. 900	18	4.4	2	291
19. 28	19	4.4	3	291–292
20. 500	20	4.4	4, 5	292–293

> Cumulative Review Chapters 1–4

1. Write nine thousand, eight hundred ten in standard form.
2. Write the prime factors of 56.
3. Multiply: $2^3 \times 7 \times 4^0$
4. Simplify: $25 \div 5 \cdot 5 + 7 - 3$
5. Classify $\frac{9}{7}$ as proper or improper.
6. Write $\frac{39}{4}$ as a mixed number.
7. Write $7\frac{2}{3}$ as an improper fraction.
8. Multiply: $\frac{1}{2} \cdot 3\frac{1}{7}$
9. Multiply: $\left(\frac{3}{7}\right)^2 \cdot \frac{1}{9}$
10. Divide: $\frac{8}{5} \div 2\frac{2}{7}$
11. Add: $7\frac{2}{3} + 1\frac{3}{5}$
12. Subtract: $5\frac{1}{4} - 1\frac{7}{8}$
13. Translate and solve: $\frac{7}{9}$ less than a number c is $\frac{1}{2}$. What is c ?
14. Find a number such that $\frac{11}{12}$ of it is $7\frac{1}{10}$.
15. Give the word name for 241.35.
16. Write 44.874 in expanded form.
17. Add: $36.454 + 9.69$
18. Subtract: $342.42 - 13.5$
19. Multiply: $0.554 \cdot 0.15$
20. Divide: $\frac{135}{0.27}$
21. Round 449.851 to the nearest ten.
22. Divide: $10 \div 0.13$ (Round answer to two decimal digits.)
23. Write $\frac{7}{12}$ as a decimal.
24. Write 0.15 as a reduced fraction.
25. Write $0.\overline{84}$ as a reduced fraction.
26. What decimal part of 12 is 9?
27. Arrange in order of decreasing magnitude and write using the $>$ sign: 6.435 6.435 6.435
28. Insert $=$, $<$, or $>$ to make a true statement:
 0.89 _____ $\frac{7}{20}$
29. Solve for x : $x + 2.5 = 6.5$
30. Solve for y : $2.1 = 0.3y$
31. Solve for z : $9 = \frac{z}{6.9}$
32. The ratio of cars to people in Austria is 495 to 1000. Write this ratio as a fraction in reduced form.
33. Write the following proportion: 6 is to 2 as 54 is to x .
34. There is a law stating that the ratio of width to length for the American flag should be 10 to 19. Is a flag measuring 50 by 97 feet of the correct ratio?
35. Solve the proportion: $\frac{j}{5} = \frac{6}{150}$
36. Solve the proportion: $\frac{20}{c} = \frac{4}{3}$
37. A worker in an assembly line takes 9 hours to produce 25 parts. At that rate how many parts can she produce in 36 hours?
38. A salesperson traveled 600 miles on 17 gallons of gas. How many miles per gallon did the salesperson get? (Round to the nearest whole number.)
39. A 24-ounce jar of peanut butter costs \$2.89. What is the unit price in cents per ounce? (Answer to the nearest cent.)
40. A pound of lawn food covers 120 square feet of lawn. How many pounds are needed to cover a lawn measuring 80 by 60 feet (4800 square feet)?
41. The protein RDA for males is 56 grams per day. Two ounces of a certain product provide 4 grams of protein. How many ounces of the product are needed to provide 48 grams of protein?
42. The cost of 80 shares of Fly-by-Night Airline is \$87.50. How many shares can you buy with \$875.00?

This page intentionally left blank

Section

Chapter

- 5.1 Percent Notation
- 5.2 Percent Problems
- 5.3 Solving Percent Problems Using Proportions
- 5.4 Taxes, Interest, Commissions, and Discounts
- 5.5 Applications: Percent of Increase or Decrease
- 5.6 Consumer Credit

5

five

▶ Percent

The Human Side of Mathematics

What is a percent? It is a way of expressing ratios in terms of whole numbers. In this chapter, you will learn that converting a ratio or fraction of the form $\frac{a}{b}$ to a percent is as easy as 1, 2, 3. Here are the steps:

1. Divide a by b .
2. Multiply by 100.
3. Append the % sign. For example,
 $\frac{3}{4} = 0.75 \times 100 = 75\%$

But where did the % sign come from? It evolved from a symbol introduced in an anonymous Italian manuscript of 1425, where the author used the symbol $\text{P} \leftarrow \text{C}$ instead of “per cent” or “by the hundred.” By about 1650 the symbol evolved to $\text{C} \leftarrow \text{C}$ and our modern %.

The % symbol has been used since the end of the fifteenth century in interest computations, profit-and-loss documents, and taxes. As a matter of fact, when the Roman emperor Augustus levied a tax on all goods sold at auction, the official rate was 1%. As arithmetic books appeared near the end of that century, the use of percent became well established. If you remember your Roman numerals, recall that X stands for 10 and C for 100, so Giorgio Chiarino (1481) used “XX. per .C.” for 20 percent and “VIII in X perceto” to mean 8 to 10 percent.



5.1

Percent Notation

▶ Objectives

You should be able to:

- A > Convert a percent to a decimal.
- B > Convert a decimal to a percent.
- C > Convert a percent to a fraction.
- D > Convert a fraction to a percent.
- E > Solve applications involving the concepts studied.

▶ To Succeed, Review How To . . .

1. Write a ratio as a reduced fraction. (pp. 127–129, 268–271)
2. Divide a number by 100. (pp. 227–228)

▶ Getting Started

The ad says you can get a condominium for “just 5% down.” The symbol % (read “percent”) means *per hundred*. Thus, the ad states that for every \$100 the condominium costs, the buyer will have to pay \$5 at the time of purchase.



Just 5% down!

Get it all together in a

Meadowood Condominium

The word **percent** comes from the Latin phrase “*per centum*,” which means “*per hundred*” The “*per*” indicates a division and the “*centum*” indicates that the division will be by 100. We use the symbol % to indicate a percent. Thus, instead of saying “5 per hundred” we simply write 5%. As you recall, the 5% can be written in at least three ways:

1. As the **ratio** 5 to 100
2. As the **fraction** $\frac{5}{100}$
3. As the **decimal** 0.05

In this section, we will learn how to convert from one of these forms to another.

A > Converting from Percent to Decimal Notation

Since % means per hundred, numbers written as percents can be converted to decimals by dividing by 100, that is, by moving the decimal point two places to the left (see Objective E in Section 3.2). Look for the patterns in the conversions.

$$37\% = \frac{37}{100} = 0.37$$

$$4\% = \frac{4}{100} = 0.04$$

$$129\% = \frac{129}{100} = 1.29$$

Thus, to change a percent to a decimal, we use this rule:

CONVERTING A PERCENT TO A DECIMAL

Move the decimal point in the number *two* places to the *left* and omit the % symbol.

For example,

$$\begin{aligned} 93\% &= .93 = 0.93 \\ 41\% &= .41 = 0.41 \\ 147\% &= 1.47 = 1.47 \end{aligned}$$

EXAMPLE 1 Converting percents to decimals

Write as a decimal.

a. 49%

b. 23.7%

SOLUTION 1

a. $49\% = .49 = 0.49$

b. $23.7\% = .237 = 0.237$

PROBLEM 1

Write as a decimal.

a. 47%

b. 493%

If the given percent involves a fraction, we first write the fractional part as a decimal and then move the decimal two places to the left. Thus, to write $12\frac{1}{2}\%$ as a decimal, we write

$$12\frac{1}{2}\% = 12.5\% = .125 = 0.125$$

EXAMPLE 2 Converting percents to decimals

Write as a decimal.

a. $3\frac{1}{4}\%$

b. $18\frac{2}{3}\%$

SOLUTION 2

a. $3\frac{1}{4}\% = 3.25\% = .0325 = 0.0325$

b. Since $\frac{2}{3} = 0.666\dots = 0.\bar{6}$,

$$18\frac{2}{3}\% = 18.\bar{6}\% = .18\bar{6} = 0.18\bar{6}$$

PROBLEM 2

Write as a decimal.

a. $2\frac{1}{8}\%$

b. $5\frac{1}{3}\%$

B > Converting from Decimal to Percent Notation

Since % means *per hundred*, to convert a decimal to a percent, we first convert the decimal to hundredths and then write the hundredths as a percent. For example,

$$\begin{aligned} 0.17 &= \frac{17}{100} = 17\% \\ 0.02 &= \frac{2}{100} = 2\% \\ 4.11 &= \frac{411}{100} = 411\% \end{aligned}$$

Answers to PROBLEMS

1. a. 0.47 b. 4.93

2. a. 0.02125 b. $0.05\bar{3}$

Here is the rule we use.

CONVERTING A DECIMAL TO A PERCENT

Move the decimal point *two* places to the *right* and attach the % symbol.

Thus,

$$0.43 = 043.\% = 43\%$$

$$0.09 = 009.\% = 9\%$$

EXAMPLE 3 Converting decimals to percents

Write as a percent.

- a. 0.05 b. 4.19 c. 81.2

SOLUTION 3

a. $0.05 = 005.\% = 5\%$

b. $4.19 = 419.\% = 419\%$

c. $81.2 = 8120.\% = 8120\%$

PROBLEM 3

Write as a percent.

- a. 0.07 b. 3.14 c. 71.8

C > Converting from Percent to Fraction Notation

Since % means *per hundred*,

$$5\% = \frac{5}{100} = \frac{1}{20}$$

$$7\% = \frac{7}{100}$$

$$23\% = \frac{23}{100}$$

$$4.7\% = \frac{4.7}{100}$$

$$134\% = \frac{134}{100} = \frac{67}{50}$$

Thus, we can convert a number written as a percent to a fraction by using the following rule:

CONVERTING A PERCENT TO A FRACTION

Write the *number* over 100, *reduce* the fraction, and omit the % sign.

EXAMPLE 4 Converting percents to fractions

Write as a fraction.

- a. 49% b. 75%

SOLUTION 4

a. $49\% = \frac{49}{100}$

b. $75\% = \frac{75}{100} = \frac{3}{4}$

PROBLEM 4

Write as a fraction.

- a. 41% b. 25%

Answers to PROBLEMS

3. a. 7% b. 314% c. 7180% 4. a. $\frac{41}{100}$ b. $\frac{1}{4}$

In case the number involves a fraction or a decimal, we follow a similar procedure. Thus,

$$12\frac{1}{2}\% = \frac{12\frac{1}{2}}{100} = \frac{\frac{25}{2}}{100} = \frac{25}{2} \div 100 = \frac{25}{2} \times \frac{1}{100} = \frac{25}{200} = \frac{1}{8}$$

$$16.5\% = \frac{16.5}{100} = \frac{16.5 \times 10}{100 \times 10} = \frac{165}{1000} = \frac{33}{200}$$

Note that 16.5 has *one* decimal digit, so we multiplied by 10.

EXAMPLE 5 Converting percents to fractions

Write as a fraction.

a. $5\frac{1}{2}\%$

b. 15.55%

SOLUTION 5

a. $5\frac{1}{2}\% = \frac{5\frac{1}{2}}{100} = \frac{\frac{11}{2}}{100} = \frac{11}{200}$

b. $15.55\% = \frac{15.55}{100} = \frac{15.55 \times 100}{100 \times 100} = \frac{1555}{10,000} = \frac{311}{2000}$

PROBLEM 5

Write as a fraction.

a. $3\frac{1}{3}\%$

b. 4.5%

D > Converting from Fraction to Percent Notation

How do we write a fraction as a percent? If the fraction has a denominator that is a factor of 100, it is easy. To write $\frac{1}{5}$ as a percent, we first multiply numerator and denominator by a number that will make the denominator 100. Thus,

$$\frac{1}{5} = \frac{1 \times 20}{5 \times 20} = \frac{20}{100} = 20\%$$

Similarly,

$$\frac{3}{4} = \frac{3 \times 25}{4 \times 25} = \frac{75}{100} = 75\%$$

Note that in both cases the denominator of the fraction was a factor of 100.

EXAMPLE 6 Converting a fraction to a percent

Write $\frac{4}{5}$ as a percent.

SOLUTION 6 $\frac{4}{5} = \frac{4 \times 20}{5 \times 20} = \frac{80}{100} = 80\%$

PROBLEM 6

Write $\frac{2}{3}$ as a percent.

In Example 6 the denominator of $\frac{4}{5}$, the 5, was a *factor* of 100. Suppose we wish to change $\frac{1}{6}$ to a percent. The problem here is that 6 is *not* a factor of 100. Don't panic! We can write $\frac{1}{6}$ as a percent by dividing the numerator 1 by the denominator 6. Divide 1 by 6, continuing the division until we have two decimal digits:

$$\begin{array}{r} 0.16 \\ 6 \overline{)1.00} \\ \underline{6} \\ 40 \\ \underline{36} \\ 4 \text{ remainder} \end{array}$$

Answers to PROBLEMS

5. a. $\frac{1}{30}$ b. $\frac{9}{200}$ 6. 40%

The answer is 0.16 with remainder 4; that is,

$$\frac{1}{6} = 0.16\frac{4}{6} = 0.16\frac{2}{3} = \frac{16\frac{2}{3}}{100} = 16\frac{2}{3}\%$$

Similarly, $\frac{2}{3}$ can be written as a percent by dividing 2 by 3, obtaining

$$\begin{array}{r} 0.66 \\ 3 \overline{)2.00} \\ \underline{18} \\ 20 \\ \underline{18} \\ 2 \end{array} \quad \text{remainder}$$

Thus,

$$\frac{2}{3} = 0.66\frac{2}{3} = \frac{66\frac{2}{3}}{100} = 66\frac{2}{3}\%$$

Here is the rule we need.

CONVERTING A FRACTION TO A PERCENT

Divide the *numerator* by the *denominator* (carry the division to two decimal places), convert the resulting decimal to a percent by *moving the decimal point two places to the right*, and attach the % symbol.

EXAMPLE 7 Converting a fraction to a percent

Write $\frac{5}{8}$ as a percent.

SOLUTION 7 Dividing 5 by 8, we have

$$\begin{array}{r} 0.62 \\ 8 \overline{)5.00} \\ \underline{48} \\ 20 \\ \underline{16} \\ 4 \end{array}$$

Thus,

$$\frac{5}{8} = 0.62\frac{4}{8} = 0.62\frac{1}{2} = 0.62\frac{1}{2}\% = 62\frac{1}{2}\%$$

PROBLEM 7

Write $\frac{3}{16}$ as a percent.

E > Applications Involving Percents

GREEN MATH

EXAMPLE 8 Energy use in an average home

The graph shows how energy is used in an average home with four family members.

- Write 7% as a reduced fraction and as a decimal.
- Write 48% as a reduced fraction and as a decimal.

SOLUTION 8

- $7\% = \frac{7}{100} = 0.07$ (Note that $\frac{7}{100}$ can't be reduced any further.)
- $48\% = \frac{48}{100} = \frac{12}{25}$ and $\frac{48}{100} = 0.48$

PROBLEM 8

- Write 31% as a reduced fraction and as a decimal.
- Write 14% as a reduced fraction and as a decimal.

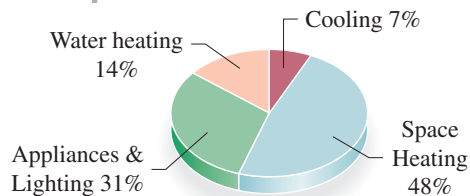

Answers to PROBLEMS

7. $18\frac{3}{4}\%$ 8. a. $\frac{31}{100} = 0.31$ b. $\frac{14}{100} = \frac{7}{50}$ and $\frac{14}{100} = 0.14$

As a final helpful item, here are some of the most-used decimal-fraction-percent equivalents.

Decimal-Fraction-Percent Equivalents								
Fraction	$\frac{1}{8}$	$\frac{1}{6}$	$\frac{1}{5}$	$\frac{1}{4}$	$\frac{1}{3}$	$\frac{3}{8}$	$\frac{2}{5}$	$\frac{1}{2}$
Decimal	0.125	$0.1\overline{6}$	0.2	0.25	$0.\overline{3}$	0.375	0.4	0.5
Percent	$12\frac{1}{2}\%$	$16\frac{2}{3}\%$	20%	25%	$33\frac{1}{3}\%$	$37\frac{1}{2}\%$	40%	50%
Fraction	$\frac{3}{5}$	$\frac{5}{8}$	$\frac{2}{3}$	$\frac{3}{4}$	$\frac{4}{5}$	$\frac{5}{6}$	$\frac{7}{8}$	1
Decimal	0.6	0.625	$0.\overline{6}$	0.75	0.8	$0.8\overline{3}$	0.875	1.0
Percent	60%	$62\frac{1}{2}\%$	$66\frac{2}{3}\%$	75%	80%	$83\frac{1}{3}\%$	$87\frac{1}{2}\%$	100%

You should try to become familiar with the table before attempting the exercises.

EXAMPLE 9 Converting fractions, decimals, and percents

Mimi's Cafe has a 300-person seating capacity. If 60 persons can sit in the Garden Room,

- What fraction of the persons can sit in the Garden Room?
- What percent of the persons can sit in the Garden Room?
- Write the fraction of the persons that can sit in the Garden Room as a decimal.



SOLUTION 9

- a. 60 out of 300 can sit in the Garden Room, that is,

$$\frac{60}{300} = \frac{1}{5} \text{ of the persons.}$$

- b. To convert $\frac{1}{5}$ to a decimal, divide 1 by 5, or look at the chart preceding this example.
In either case, $\frac{1}{5} = 20\%$.
- c. To write $\frac{1}{5}$ as a decimal, divide 1 by 5 or look at the chart.
In either case, $\frac{1}{5} = 0.20$.

PROBLEM 9

Beto's Mexican Restaurant has a 200-person seating capacity. If 45 persons can sit in the Guadalajara Room:

- What fraction of the persons can sit in the Guadalajara Room?
- What percent of the persons can sit in the Guadalajara Room?
- Write the fraction of the persons that can sit in the Guadalajara Room as a decimal.

Calculator Corner

Some calculators have a special percent key, $\boxed{\%}$, that will automatically change percents to decimals. Thus, to do Example 4(a): Change 49% to a decimal by pressing **4** **9** $\boxed{\%}$. The display shows the decimal representation 0.49. Similarly, to change 23.7% to a decimal, key in **2** **3** **.** **7** $\boxed{\%}$ and the answer 0.237 will be displayed.

If you *do not* have a $\boxed{\%}$ key, you can still use the rule given in the text; that is, divide the number by 100. Thus, to convert 23.7% to a decimal, enter **2** **3** **.** **7** $\boxed{\div}$ **1** **0** **0** **ENTER**. The answer, 0.237, will be displayed.

Answers to PROBLEMS

9. a. $\frac{9}{40}$ b. $22\frac{1}{2}\%$ c. 0.225



> Practice Problems > Self-Tests
> Media-rich eBooks > e-Professors > Videos

> Exercises 5.1

< A > Converting from Percent to Decimal Notation In Problems 1–12, write as a decimal.

- | | | | | |
|----------|----------------------|----------------------|----------|-----------|
| 1. 3% | 2. 2% | 3. 10% | 4. 15% | 5. 300% |
| 6. 100% | 7. $12\frac{1}{4}\%$ | 8. $10\frac{1}{4}\%$ | 9. 11.5% | 10. 0.09% |
| 11. 0.3% | 12. 0.1% | | | |

< B > Converting from Decimal to Percent Notation In Problems 13–22, write as a percent.

- | | | | | |
|----------|----------|-----------|-----------|-----------|
| 13. 0.04 | 14. 0.06 | 15. 0.813 | 16. 0.312 | 17. 3.14 |
| 18. 9.31 | 19. 1.00 | 20. 2.1 | 21. 0.002 | 22. 0.314 |

< C > Converting from Percent to Fraction Notation In Problems 23–36, write as a (reduced) fraction.

- | | | | | |
|----------|----------------------|----------------------|----------------------|----------------------|
| 23. 30% | 24. 40% | 25. 6% | 26. 2% | 27. 7% |
| 28. 19% | 29. $4\frac{1}{2}\%$ | 30. $2\frac{1}{4}\%$ | 31. $1\frac{1}{3}\%$ | 32. $5\frac{2}{3}\%$ |
| 33. 3.4% | 34. 6.2% | 35. 10.5% | 36. 20.5% | |

< D > Converting from Fraction to Percent Notation In Problems 37–50, write as a percent.

- | | | | | |
|----------------------|----------------------|--------------------|--------------------|-------------------|
| 37. $\frac{3}{5}$ | 38. $\frac{4}{25}$ | 39. $\frac{1}{2}$ | 40. $\frac{3}{50}$ | 41. $\frac{5}{6}$ |
| 42. $\frac{1}{3}$ | 43. $\frac{3}{8}$ | 44. $\frac{7}{8}$ | 45. $\frac{4}{3}$ | 46. $\frac{7}{6}$ |
| 47. $\frac{81}{100}$ | 48. $\frac{10}{100}$ | 49. $\frac{3}{20}$ | 50. $\frac{7}{20}$ | |

< E > Applications Involving Percents

51. *Success in your first year* Which courses are most important to a student's first-year success? The results are in the chart.

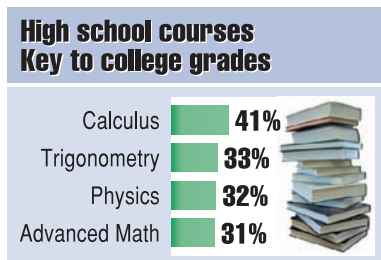

Source: ACT Inc., Information for Life Transitions.

- Write 41% as a fraction and as a decimal.
- Write 33% as a fraction and as a decimal.
- Write 32% as a reduced fraction and as a decimal.
- Write 31% as a fraction and as a decimal.

52. *Popular cell phone features* Which are the most popular cell phone features? The results are in the chart.

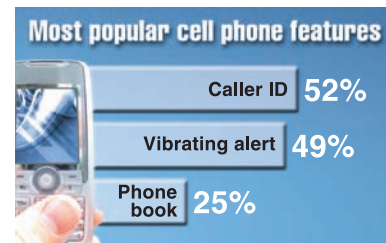

Source: Sony Ericson Mobile Communications.

- Write 52% as a reduced fraction and as a decimal.
- Write 49% as a fraction and as a decimal.
- Write 25% as a reduced fraction and as a decimal.

- 53. Cell phones** Now that you know the desirable features in a cell phone, where are cell phones not welcome? The chart tells you!



Source: Opinion Research Corporation for Cingular Wireless.

- Write 44% as a reduced fraction and as a decimal.
 - Write 20% as a reduced fraction and as a decimal.
 - Write 15% as a reduced fraction and as a decimal.
- 55. Internet use** Do you use the Internet? Assume there are currently 300 million people in the United States, and 210 million of them use the Internet.
- What reduced fraction of the people use the Internet?
 - What percent of the people use the Internet?
 - Write the percent of people using the Internet as a decimal rounded to the nearest hundredth.
- 57. Internet use** Of the 210 million people that use the Internet, 165 million have made a purchase online:
- What fraction of the people made a purchase online?
 - What percent of the people made a purchase online? (Answer to the nearest percent.)
 - Write the fraction of people that made a purchase online as a decimal rounded to the nearest hundredth.

- 54. Bathroom time** How long do you spend in the bathroom? Adults ages 30 to 70 spend an hour a day, almost two weeks a year, in the bathroom. Look at the chart to see what they are doing.



Source: Yankelovich Partners.

- Write 53% as a fraction and as a decimal.
 - Write 47% as a fraction and as a decimal.
 - Write 33% as a fraction and as a decimal.
- 56. Internet use** Of the 210 million people that use the Internet, 145 million use it at home.
- What fraction of the people use the Internet at home?
 - What percent of the people use the Internet at home? (Answer to the nearest percent.)
 - Write the percent of people using the Internet at home as a decimal rounded to the nearest hundredth.

Applications: Green Math

A Princeton Review Survey says most college applicants today are becoming increasingly interested in how green their prospective universities are. What did the survey say? We shall see next.

- 58. Princeton survey** **7 Out of 10 College Bound Students Prefer Green Universities**
- Write 7 out of 10 as a fraction.
 - Write 7 out of 10 as a decimal.
 - Write 7 out of 10 as a percent.
- 60. Transportation survey** A total of 593 surveys were distributed by Advanced Transit Systems of Vermont and New Hampshire and 572 were returned.
- What was the response rate? Answer to one decimal digit.
 - 395 of the 572 respondents said "Work" was their primary trip purpose. What percent is that? Answer to the nearest percent.
 - 148 of the 572 respondents said their trip involved a transfer between bus routes. What percent is that? Answer to the nearest percent.
- 59. More Princeton survey** The survey was taken from a poll of 12,715 college-bound high school seniors and 3005 of their parents.
- 8646 of the 12,715 students say they were interested in green ratings. What percent is that? Answer to the nearest percent.
 - 890 students say the level of importance of the green ratings was "strong." What percent is that? Answer to the nearest percent.
 - About 3000 parents and 12,700 students participated in the survey. What percent of the participants were parents? Answer to the nearest percent.
- 61. More of the survey** How often do people use the bus? We shall see now!
- Five days a week: 286 of the 572. To the nearest percent, what percent is that?
 - Three or four days a week: 190 of the 572. To the nearest percent, what percent is that?
 - Combined total who ride three or more days a week: 469 of the 572. To the nearest percent, what percent is that?
- How do these results compare with your transportation usage?

- 62. HAP (hazardous air pollution)** Do you have a Hazardous Air Pollutant (HAP) Inventory in your county or state? In Hillsborough County, about 14,000 tons of HAPs were emitted. If about 7000 came from point sources such as power plants:
- What reduced fraction of the HAPs came from point sources?
 - What percent of the HAPs came from point sources?
 - Write the percent of the HAPs coming from point sources as a decimal.
- 63. HAP** If about 4200 tons of the 14,000 tons (see Problem 62) came from mobile sources such as on-road vehicles:
- What reduced fraction of the HAPs came from mobile sources?
 - What percent of the HAPs came from mobile sources?
 - Write the percent of the HAPs coming from mobile sources as a decimal.
- 64. Surveys** In a mythical survey of 300 chinchillas, the number expressing the concerns listed are as follows:
- Eating too little, 30. What reduced fraction is that? What percent is that?
 - Losing fur patches, 33. What reduced fraction is that? What percent is that?
 - Had no problems, 34. What reduced fraction is that? What percent is that (to the nearest percent)?
 - Eating too much, 87. What reduced fraction is that? What percent is that?
 - Acting weird, 126. What reduced fraction is that? What percent is that?

If you actually want to see a pie chart for these outcomes, go to <http://www.one38.org/1000/piecharts/issue03/chinchilla.html>.

Source: Environmental Protection Agency.

Online poll The following information will be used in Problems 65–68.

An Excite Today Online Poll asked the question: Have you ever taken medication to help you fall asleep? The results are shown next.

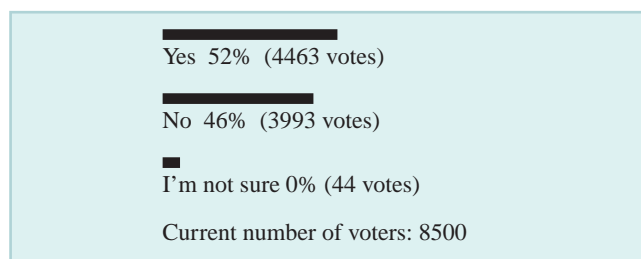

Source: Excite.com http://poll.excite.com/poll/results.jsp?cat_id=1&poll_id=7.

- 65.** Of the respondents, 52% said they have taken medication to help them fall asleep:
- Write 52% as a reduced fraction.
 - Write 52% as a decimal.
- 66.** Of the respondents, 46% said they have *not* taken medication to help them fall asleep:
- Write 46% as a decimal.
 - Write 46% as a reduced fraction.
- 67.** In the survey, 52% of the respondents answered *Yes*, 46% answered *No*, and 0% were *not sure*. Do the totals add to 100%? Explain.
- 68.** In the survey, 4463 respondents out of 8500 answered *Yes* and 3993 answered *No*.
- Write the number of respondents answering *Yes* as a fraction (do not reduce).
 - Convert the fraction in part **a** to a percent rounded to the nearest tenth.
 - Write the fraction of respondents answering *No* as a fraction (do not reduce).
 - Convert the fraction in part **c** to a percent rounded to the nearest tenth.
 - What about the 44 respondents out of 8500 who were *not sure*? Write the number of respondents *not sure* as a percent rounded to the nearest tenth.
 - Do the totals add to 100% now?

Using Your Knowledge

The Pursuit of Happiness Recently the magazine *Psychology Today* conducted a survey about happiness. Here are some conclusions from that report:

- 69.** 7 out of 10 people said they had been happy over the last six months. What percent of the people is that?
- 70.** 70% expected to be happier in the future than now. What fraction of the people is that?
- 71.** 0.40 of the people felt lonely.
- What percent of the people is that?
 - What fraction of the people is that?
- 72.** Only 4% of the men were ready to cry. Write 4% as a decimal.

5.2

Percent Problems

▶ Objectives

You should be able to:

- A > Find the percentage when the base and rate are given.
- B > Find the percent when the base and percentage are given.
- C > Find the base when the percentage and percent are given.
- D > Solve applications involving the concepts studied.

▶ To Succeed, Review How To . . .

1. Write a percent as a fraction or as a decimal. (pp. 306–309)
2. Use the **RSTUV** procedure to solve word problems. (pp. 95, 186)
3. Solve equations involving decimals. (pp. 251–255)

▶ Getting Started

In the cartoon, the chairman of the board of Mogul Oil wishes to have a 300% increase in profit. If he had a profit of \$10 million last year, by how much does he want to increase his profit? Since $300\% = \frac{300}{100} = 3.00 = 3$, he wishes to increase his profit by

$$\begin{array}{ccc} 300\% & \text{of} & 10 \\ \downarrow & \swarrow & \searrow \\ 3 & \times & 10 = 30 \end{array} \begin{array}{l} \text{(million)} \\ \\ \text{(million)} \end{array}$$

Thus, he wishes to increase his profit by \$30 million.

FUNKY WINKERBEAN

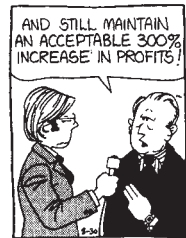
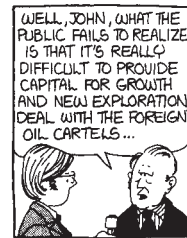
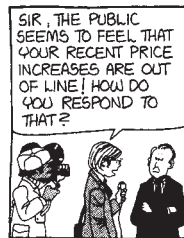
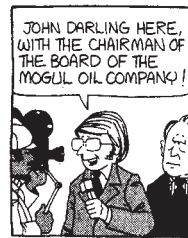

Tom Batiuk

FUNKY WINKERBEAN © 1974 BATOM, INC. NORTH AMERICAN SYNDICATE

A > Finding the Percentage

As you can see from the example in the *Getting Started*, there are three quantities involved:

1. The **base**, or **total** (the standard used for comparison purposes)
2. The **percentage** (the part being compared with the base or total)
3. The **percent**, or **rate** (the part indicating the ratio of the percentage to the base)

Note that the *percent*, or *rate*, is usually written using the symbol %, but the *percentage* is a number. In the preceding example the *base*, or *total*, is \$10 million, the *percentage* is 30, and the *percent* is 300%. In this section, you will be asked to find the percentage P , the percent, or rate, R , or the base B when the other two are given. To do this, we will use the **RSTUV** procedure studied in Sections 1.9, 2.8, and 3.5 along with the following dictionary.

Word	Translation	Symbol
of	multiply	· or \times
is	equal	=
what	variable or letter	x, y, \square
percent	decimal or fraction	$\times \frac{1}{100}$ or 0.01

Let us solve a problem: 40% of 60 is what number? Here are the steps:

Step 1. Read the problem.

Step 2. Select a variable to represent the unknown. The *base* is 60 and the *percent* is 40%; we need to know the percentage P .

Step 3. Translate the problem into an equation.

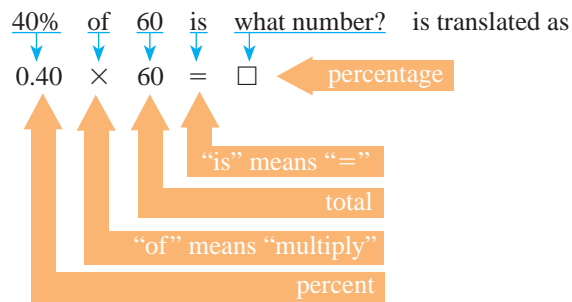

Step 4. Use the rules studied to solve the equation. (Remember to write all percents as decimals or fractions *before* solving the equation.)

$$\begin{aligned} 0.40 \times 60 &= P && \text{Given.} \\ 24 &= P && \text{Multiply.} \end{aligned}$$

Thus, 40% of 60 is 24.

Step 5. Verify that the answer is correct.

Since $\frac{24}{60} = 0.40 = 40\%$, our answer is correct.

EXAMPLE 1 Finding the percentage of a number

60% of 30 is what number?

SOLUTION 1

Step 1. Read the problem.

Step 2. Select a variable to represent the unknown. Let P be the unknown.

Step 3. Translate into an equation.

60% of 30 is what number?

$$0.60 \times 30 = P$$

Step 4. Use the rules studied to solve the equation.

$$\begin{aligned} 0.60 \times 30 &= P && \text{Given.} \\ 18 &= P && \text{Multiply.} \end{aligned}$$

Thus, 60% of 30 is 18.

Step 5. Verify that the answer is correct.

PROBLEM 1

70% of 40 is what number?

If the given percent involves a fraction, try to write the fractional part as a decimal by dividing numerator by denominator, as shown in Example 2.

Answers to PROBLEMS

1. 28

EXAMPLE 2 Finding the percentage of a numberFind $12\frac{1}{2}\%$ of 80.**SOLUTION 2****Step 1.** Read the problem.**Step 2.** Select a variable to represent the unknown. Let P be the unknown.**Step 3.** Translate into an equation.

$$12\frac{1}{2}\% \text{ of } 80 \text{ is what number?}$$

$$0.12\frac{1}{2} \times 80 = P$$

$$0.125 \times 80 = P$$

Step 4. Use the rules studied to solve the equation.

$$0.125 \times 80 = P \quad \text{Given.}$$

$$10.000 = P \quad \text{Multiply.}$$

Thus, $12\frac{1}{2}\%$ of 80 is 10.**Step 5.** Verify that the answer is correct.**PROBLEM 2**Find $8\frac{1}{2}\%$ of 60.

If the given percent involves a fraction that cannot be converted to a terminating decimal, look in the table given in Section 5.1 for its fractional equivalent, as shown in Example 3.

EXAMPLE 3 Finding the percentage of a numberWhat is $33\frac{1}{3}\%$ of 84?**SOLUTION 3****Step 1.** Read the problem.**Step 2.** Select a variable to represent the unknown. Let P be the unknown.**Step 3.** Translate into an equation.

$$33\frac{1}{3}\% \text{ of } 84 \text{ is what number?}$$

$$\frac{1}{3} \times 84 = P$$

From the table in Section 5.1, $33\frac{1}{3}\% = \frac{1}{3}$ because

$$33\frac{1}{3}\% = \frac{\frac{100}{3}}{100} = \frac{100}{3} \cdot \frac{1}{100} = \frac{1}{3}$$

Step 4. Use the rules studied to solve the equation.

$$\frac{1}{3} \times 84 = P \quad \text{Given.}$$

$$28 = P \quad \text{Multiply.}$$

Thus, $33\frac{1}{3}\%$ of 84 is 28.**Step 5.** Verify that the answer is correct.**PROBLEM 3**What is $66\frac{2}{3}\%$ of 90?

Prices start at
\$81,500
as little as \$8,150 down.

We pay closing costs!

wood Condominium

B > Finding the Percent

Here is another type of problem. The prices in the ad start at \$81,500 and you can pay \$8150 down. What *percent* is that? This problem can be stated in different ways. Here are some of them:

8150 is what percent of 81,500?

Find what percent of 81,500 is 8150.

What percent of 81,500 is 8150?

Answers to PROBLEMS

2. 5.1 3. 60

As before, we use the **RSTUV** procedure to solve the problem.

Step 1. Read the problem.

Step 2. Select a variable to represent the unknown. Let R be the unknown.

Step 3. Translate into an equation.

What percent of 81,500 is 8150?

$$R \times 81,500 = 8150$$

Step 4. Use the rules studied to solve the equation.

$$R \times 81,500 = 8150 \quad \text{Given.}$$

$$R = \frac{8150}{81,500} = \frac{1}{10} \quad \text{Divide by 81,500.}$$

Since we are looking for a percent, we must convert $\frac{1}{10}$ to a percent. Thus,

$$R = \frac{1}{10} = \frac{1 \cdot 10}{10 \cdot 10} = \frac{10}{100} = 10\%$$

Thus, \$8150 is 10% of \$81,500.

Step 5. Verify the answer.

Is it true that 10% of 81,500 is 8150? Yes

($0.10 \times 81,500 = 8150$). Thus, our answer is correct.

EXAMPLE 4 Finding the percent of a number

Find what percent of 40 is 20.

SOLUTION 4

Step 1. Read the problem.

Step 2. Select a variable to represent the unknown. Let R be the unknown.

Step 3. Translate into an equation.

What percent of 40 is 20?

$$R \times 40 = 20$$

Step 4. Use the rules studied to solve the equation.

$$R \times 40 = 20 \quad \text{Given.}$$

$$R = \frac{20}{40} = \frac{1}{2} \quad \text{Divide by 40.}$$

Since we are looking for a percent, we must convert $\frac{1}{2}$ to a percent. Thus

$$R = \frac{1}{2} = \frac{1 \cdot 50}{2 \cdot 50} = \frac{50}{100} = 50\%$$

Thus, 50% of 40 is 20.

Step 5. Verify the answer.

Is it true that 50% of 40 is 20? Yes

($0.50 \times 40 = 20$). Thus, our answer is correct.

PROBLEM 4

Find what percent of 30 is 3.

SAVE 20%
Free-moving
Body Suit and Jeans
both machine washable
REGULAR PRICE **30.00** each

C > Finding the Base

Suppose you save \$6 when buying the article in the ad. Verify the regular (base) price of the article. To find the answer, we use the **RSTUV** procedure.

Answers to PROBLEMS

4. 10%

Step 1. Read the problem.

Step 2. Select a variable to represent the unknown. Let B be the unknown.

Step 3. Translate the problem. Since you save \$6, which is equivalent to the 20%, the equation would be

$$20\% \text{ of } B = 6$$

$$0.20 \times B = 6$$

Step 4. Use the rules studied to solve the equation.

$$0.20 \times B = 6 \quad \text{Given.}$$

$$B = \frac{6}{0.20} \quad \text{Divide by 0.20.}$$

$$= \frac{6 \cdot 100}{0.20 \cdot 100} \quad \text{Multiply the numerator and denominator by 100.}$$

$$= \frac{600}{20} = 30 \quad \text{Simplify.}$$

(You get the same answer if you use long division to divide 6 by 0.20.)

Thus, the original (regular) price of the article was \$30.

Step 5. Verify the answer.

Is it true that 20% of 30 is 6? Yes

($0.20 \times 30 = 6$). Thus, our answer is correct.

There are different ways of stating problems in which the base is the unknown. For example, the statement “10 is 40% of what number?” can be translated as

10 is 40% of a number. Find the number.

Find a number so that 40% of it is 10.

40% of what number is equal to 10?

} All equivalent to “10 is 40% of what number.”

We solve for the base in Example 5.

EXAMPLE 5 Finding the base

10 is 40% of what number?

SOLUTION 5 As before, we use the RSTUV method.

Step 1. Read the problem.

Step 2. Select a variable to represent the unknown. Let B be the unknown.

Step 3. Translate into an equation.

10 is 40% of what number?

$$10 = 0.40 \times B$$

Step 4. Use the rules studied to solve the equation.

$$10 = 0.40 \times B \quad \text{Given.}$$

$$B = \frac{10}{0.40} \quad \text{Divide by 0.40.}$$

$$= \frac{10 \cdot 100}{0.40 \cdot 100} \quad \text{Multiply by 100.}$$

$$= \frac{1000}{40} = 25 \quad \text{Simplify.}$$

Thus, 10 is 40% of 25.

Step 5. Verify the answer.

It is true that $10 = 0.40 \times 25$.

Thus, our answer is correct.

PROBLEM 5

50 is 20% of what number?

Answers to PROBLEMS

5. 250

D > Applications Involving Percents

EXAMPLE 6 Calculating the price of an item

The sales tax on an item was \$3.64. If the tax rate is 4%, what was the price of the item?

SOLUTION 6

Step 1. Read the problem.

Step 2. Select a variable to represent the unknown. Let B dollars be the unknown.

Step 3. Translate into an equation: We know that \$3.64 is 4% of the price, so

$$3.64 = 0.04 \times B$$

Step 4. Use the rules studied to solve the equation.

$$\begin{aligned} 3.64 &= 0.04 \times B && \text{Given.} \\ B &= \frac{3.64}{0.04} && \text{Divide by 0.04.} \\ &= \frac{3.64 \cdot 100}{0.04 \cdot 100} && \text{Multiply the numerator and denominator by 100.} \\ &= \frac{364}{4} = 91 && \text{Simplify.} \end{aligned}$$

So the price was \$91.

Step 5. Verify the answer.

It is true that $\$3.64 = 0.04 \times 91$.

Thus, our answer is correct.

PROBLEM 6

The sales tax on an item was \$3.28. If the tax rate is 8%, what was the price of the item?

EXAMPLE 7 Percent problems and college costs

Natasha is a student at the University of Wisconsin. Tuition and fees for out-of-state students are about \$10,500. She has a scholarship that pays 58% of the \$10,500.

- How much does the scholarship pay and how much does Natasha have to contribute?
- Natasha has \$4000 saved to pay her part of the tuition and fees from part **a**. What percent of her part of the tuition and fees will she be paying?
- The state of Wisconsin claims that in-state students only pay 38% of the real cost of tuition and fees. If in-state tuition and fees cost about \$4500, what is the cost to the state per student?

SOLUTION 7

- a.** The scholarship pays 58% of the \$10,500

$$\text{Translation: } \begin{array}{ccc} \downarrow & \downarrow & \downarrow \\ 0.58 & \times & 10,500 = \$6090 \end{array} \quad \begin{array}{l} \text{Verify this by multiplying} \\ 0.58 \text{ by } 10,500. \text{ Be} \\ \text{careful with the decimal.} \end{array}$$

Since the scholarship pays \$6090, she pays the rest, that is, Natasha pays $\$10,500 - \$6090 = \$4410$.

- b.** She will be paying \$4000 out of the \$4410, that is, $\frac{4000}{4410} = 91\%$ (to the nearest percent).

Verify this by dividing 4000 by 4410. Write the answer to the nearest percent.

- c.** According to the problem:

$$\begin{array}{ccc} \downarrow & & \downarrow \downarrow \\ \text{Students pay } 38\% \text{ of tuition and fees, which is } \$4500 \\ \text{Translation: } 0.38 \times T & & = 4500 \end{array} \quad \begin{array}{l} \text{Let } T \text{ stand for} \\ \text{tuition and fees.} \end{array}$$

PROBLEM 7

Doug is a student at the University of South Florida. Out-of-state fees at USF are about \$7000. He has a scholarship that pays 80% of the \$7000.

- How much does the scholarship pay and how much does Doug have to contribute?
- Doug has \$1000 to pay his part of the tuition from part **a**. What percent of his part of the tuition and fees will he be paying?
- If tuition and fees cost \$1400 and this represents 25% of the state's total cost of tuition and fees, what is the state's cost per student?

(continued)

Answers to PROBLEMS

6. \$41 7. a. \$5600; \$1400 b. 71% (to the nearest percent) c. \$5600

$$\begin{aligned}
 &\text{Divide by 0.38.} \quad T = \frac{4500}{0.38} \\
 &\text{Multiply numerator, denominator by 100.} \quad = \frac{4500 \cdot 100}{0.38 \cdot 100} = \frac{450,000}{38} \\
 &\text{Divide 450,000 by 38.} \quad = \$11,842.11 \quad \text{Divide 450,000 by 38 (to the nearest cent).}
 \end{aligned}$$

Thus, it costs the state **\$11,842** per student.

GREEN MATH

EXAMPLE 8 Saving on electricity, water, and gas

- Natasha is willing to go green but wants to save on her electric bill, so she buys a ceiling fan for \$100 instead of using her air conditioner. If she saves \$665 a year on her electric bill, to the nearest percent, what percent is the \$100 investment of the \$665?
- The Department of Energy claimed that she could save 25%–60% if she changed to low-flow shower heads. If her average water bill is \$35 and she saved 25%, how much are the savings?
- Aggressive driving can lower your gas mileage by 33%. If her car gets 25 miles per gallon, how many miles per gallon would it be if she drives aggressively? Answer to two decimal places.

SOLUTION 8

- We need to find what percent 100 is of 665, that is, $\frac{100}{665} \approx 0.15 = 15\%$. Thus, Natasha saves **15%** on her bill.
- The savings are 25% of \$35 = $0.25 \times 35 =$ **\$8.75**.
- The mileage will be lowered by 33% of 25 = $0.33 \times 25 = 8.25$ miles per gallon, so her new miles per gallon would be $25 - 8.25$ or **16.75** miles per gallon.

Note that her new mileage is 67% ($100\% - 33\%$) of 25, that is, $0.67 \times 25 = 16.75$, the same answer!

PROBLEM 8

- Replacing a regular bulb with a compact fluorescent bulb costs \$32 and saves \$92 a year in electricity. To the nearest percent, what percent is the \$32 investment of the \$92 saved?
- If your water bill is \$45 and you can save 30% by using low-flow shower heads, what would be your savings?
- If your car gets 30 miles per gallon and you drive aggressively, your gas mileage will decrease by 33%. What would be your new mileage? Answer to two decimal places.

TRANSLATE THIS

- 70% of 80 is a number P .
- $12\frac{1}{2}\%$ of 200 is a number P .
- $33\frac{1}{3}\%$ of 60 is what number P ?
- What percent R of 250 is 25?
- What percent R of 80 is 40?

The third step in the RSTUV procedure is to **TRANSLATE** the information into an equation. In Problems 1–10 **TRANSLATE** the sentence and **match** the correct translation with one of the equations A–O.

- 30% of B is 40.
- 20 is 50% of what number B ?
- 0.48 is 6% of the price P of an item.
- The tax T on an item represents 10% of the cost C of the item.
- The tax T on an item is the product of its price P and its tax rate R .

- | | | | | |
|----------------------------------|-------------------------|--------------------------------|-------------------------|---------------------------|
| A. $\frac{1}{3}\% \times 60 = P$ | B. $0.80 \times 70 = P$ | C. $R \times 80 = 40$ | D. $0.70 \times 80 = P$ | E. $R \times 40 = 80$ |
| F. $0.125 \times 200 = P$ | G. $20 = 50 \times B$ | H. $0.30 \times B = 40$ | I. $R \times 250 = 25$ | J. $0.48 = 0.06 \times P$ |
| K. $20 = 0.50 \times B$ | L. $T = 0.10 \times C$ | M. $\frac{1}{3} \times 60 = P$ | N. $T = P \times R$ | O. $P = T \times R$ |

Answers to PROBLEMS

8. a. 35% b. \$13.50 c. 20.10 mpg



Calculator Corner

If your calculator has a special $\boxed{\%}$ key, you can do some of the problems in this section a little bit faster. For example, to do Example 2: Find $12\frac{1}{2}\%$ of 80 by pressing **1** **2** **.** **5** **%** **×** **8** **0** **ENTER** and the display will show the correct answer, 10. Note that the calculator *does not* do the thinking for you. You still have to know that $\frac{1}{2} = 0.5$ and that “of” means to “multiply.” As a matter of fact, the other two types of problems in the section *have to be* “set up,” using the procedure given in the text, *before* the calculator is used. To do Example 2, without a $\boxed{\%}$ key, you press **0** **.** **1** **2** **5** **×** **8** **0** **ENTER**, obtaining the same answer, 10.

> Exercises 5.2



> Practice Problems > Self-Tests
> Media-rich eBooks > e-Professors > Videos

< A > Finding the Percentage In Problems 1–14, find the percentage.

- | | | |
|--------------------------------------|-----------------------------------|--------------------------------------|
| 1. Find 40% of 80. | 2. Find 15% of 60. | 3. 150% of 8 is what number? |
| 4. 35% of 60 is what number? | 5. What is 20% of \$15? | 6. What is 95% of 40? |
| 7. Find 60% of 48. | 8. Find 120% of \$30. | 9. $12\frac{1}{2}\%$ of 40 is _____. |
| 10. $8\frac{1}{4}\%$ of 50 is _____. | 11. Find 3.5% of 60. | 12. Find 110.5% of 30. |
| 13. Find $16\frac{2}{3}\%$ of 120. | 14. Find $83\frac{1}{3}\%$ of 90. | |

< B > Finding the Percent In Problems 15–32, find the percent.

- | | | |
|---|---------------------------------------|---|
| 15. 315 is what percent of 3150? | 16. 15 is what percent of 60? | 17. 8 is what percent of 4? |
| 18. 7 is what percent of 21? | 19. Find what percent of 50 is 5. | 20. Find what percent of 40 is 8. |
| 21. What percent of 40 is 5? | 22. What percent of 15 is 10? | 23. $5\frac{1}{2}$ is what percent of 22? |
| 24. $2\frac{1}{4}$ is what percent of 27? | 25. 3 is _____ % of 5. | 26. 20 is _____ % of 30. |
| 27. 50 is _____ % of 25. | 28. 30 is _____ % of $7\frac{1}{2}$. | 29. \$50 is _____ % of \$60. |
| 30. \$90 is _____ % of \$270. | 31. \$0.75 is _____ % of \$4.50. | 32. \$0.25 is _____ % of \$1.50. |

< C > Finding the Base In Problems 33–50, find the base.

- | | | |
|--|---|---|
| 33. 30% of what number is 60? | 34. 15% of what number is 45? | 35. $2\frac{1}{4}\%$ of what number is 9? |
| 36. $5\frac{1}{2}\%$ of what number is 11? | 37. 20 is 40% of what number? | 38. 60 is 150% of what number? |
| 39. 15 is $33\frac{1}{3}\%$ of a number. Find the number. | 40. 20 is $66\frac{2}{3}\%$ of a number. Find the number. | 41. Find a number so that 120% of it is 20. |
| 42. Find a number so that $3\frac{1}{4}\%$ of it is $6\frac{1}{2}$. | 43. 40% of what number is $7\frac{1}{2}$? | 44. 140% of what number is 70? |
| 45. 4.75% of what number is 38? | 46. 3.25% of what number is 39? | 47. 100% of what number is 3? |
| 48. 8% of what number is 3.2? | 49. $12\frac{1}{2}\%$ of what number is 37.5? | 50. $33\frac{1}{3}\%$ of what number is $66\frac{2}{3}$? |

< D > Applications Involving Percents The graph will be used in Problems 51–52.

51. The U.S. population in 2000 was about 282 million. To the nearest million, how many kids were there in 2000?
52. By the year 2020, the U.S. population will swell to 386 million. To the nearest million, how many are estimated to be kids?

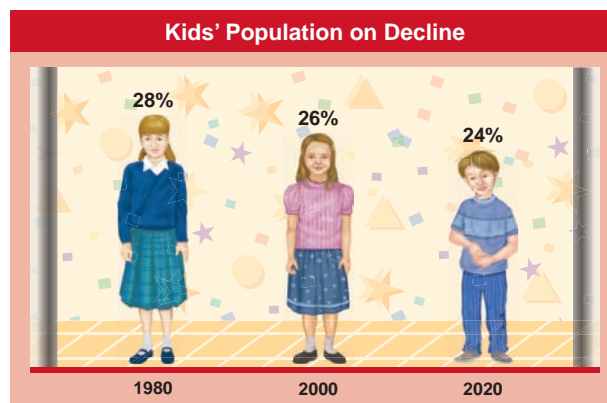

Source: Data from childstats.gov.

Saving money The graph will be used in Problems 53–56.

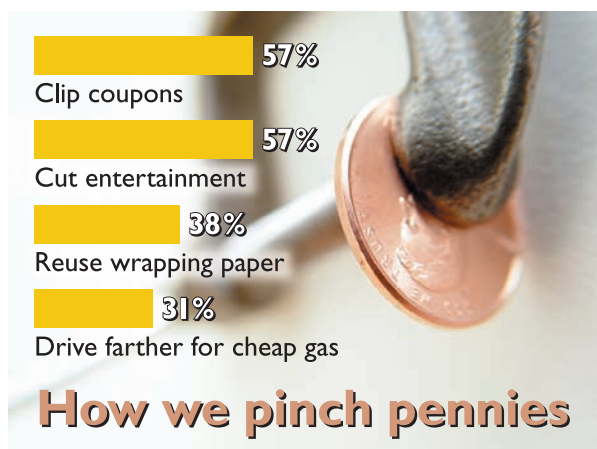

Source: Data from Progressive Insurance.

Saving for college The graph will be used in Problems 57–60.

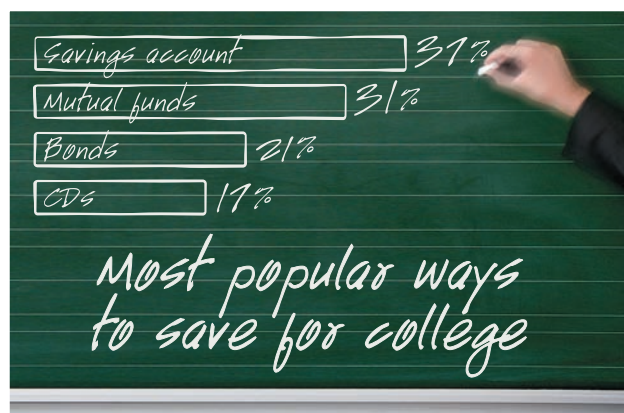

Source: Data from USA TODAY research.

53. If there were 40 members in a family, how many would you expect to clip coupons? (Answer to the nearest whole number.)
54. If there were 4000 students in a small college, how many would you expect to cut entertainment?
55. According to the graph, 38% of the people surveyed reuse wrapping paper. If 95 persons actually reuse wrapping paper, how many persons were surveyed?
56. According to the graph, 31% of the people surveyed drive farther for cheap gas. If 93 people actually drive farther to get cheap gas, how many persons were surveyed?
57. 280 parents were surveyed as to the manner in which they saved for their children's college education.
- If 112 parents used a savings account to save for college, what percent of the 280 is that?
 - Is the percent obtained in part **a** more or less than the 37% predicted by the graph?
58. 550 parents were surveyed as to the manner in which they saved for their children's college education.
- If 176 parents used mutual funds to save for college, what percent of the 550 is that?
 - Is the percent obtained in part **a** more or less than the 31% predicted by the graph?
59. If 153 of the parents saved for college by using CDs (certificates of deposit) and 153 represents 17% of the total number of parents surveyed, how many parents were surveyed?
60. If 105 of the parents saved for college using bonds and 105 represents 21% of the total number of parents surveyed, how many parents were surveyed?
61. **Oil reserves** The United States has approximately 1.75% of the world's oil reserves. This amount represents 21 billion barrels. What are the world's oil reserves?
62. **Gas reserves** Europe has approximately 3.5% of the world's gas reserves. This amount represents 210 trillion cubic feet. What are the world's gas reserves?

- 63. Coal reserves** Eastern Europe and the former USSR have approximately 30% of the world's coal reserves. This amount represents 300,000 short tons. What are the world's coal reserves?

>>> Applications: Green Math

In Exercises 64–67, savings are calculated on driving the national average of **12,500 miles** with a fuel economy of **20.1 miles per gallon (mpg)** using about **622 gallons of gas per year**. Keep these three numbers (**12,500, 20.1 and 622**) in mind; you will use them in Exercises 64–67.

- 64. Drive sensibly!** If you don't have a "lead foot" you can **improve** your mileage by 10%!
- To the nearest whole number, what would your mileage be?
 - To the nearest whole number, how many gallons a year would you use then?
 - How many gallons a year would you save if you drive sensibly?
 - How much money would you save if gas costs \$2, \$3, or \$4 a gallon?
- 65. Ditch the junk in the trunk!** An extra 100 pounds in the trunk **cuts** your gas mileage by 2%!
- To one decimal digit, what would your mileage be?
 - To the nearest whole number, how many gallons a year would you use then?
 - How many gallons a year would you save if you ditch the junk in the trunk?
 - How much money would you save if gas costs \$2, \$3, or \$4 a gallon?
- 66. Inflate your tires!** Keeping your tires properly inflated would **improve** your gas mileage by 3%!
- To one decimal digit, what would your mileage be?
 - To the nearest whole number, how many gallons a year would you use then?
 - How many gallons a year would you save if you properly inflate your tires?
 - How much money would you save if gas costs \$2, \$3, or \$4 a gallon?
- 67. Get a tune up!** Fixing a car that is out of tune will **improve** your gas mileage by 4%!
- To one decimal digit, what would your mileage be?
 - To the nearest whole number, how many gallons a year would you use then?
 - How many gallons a year would you save if you get a tune-up?
 - How much money would you save if gas costs \$2, \$3, or \$4 a gallon?

Compare your results with <http://drivesmarterchallenge.org/money-saving-tips/>.

- 68. Carbon monoxide released** In a recent year about 190 million tons of pollutants were released in the United States. Of this amount 47% was carbon monoxide. How many tons is that?
- 69. Transportation pollutants** Of the 190 million tons of pollutants in the air, 50 million tons were produced by transportation sources (cars, buses, etc.). What percent is that? (Round the answer to the nearest percent.)
- 70. Sugar and water in Coke** Do you know who invented Coca-Cola? John Pemberton did, in 1885. In 1909 an analysis of Coca-Cola revealed that 48% of the drink was sugar and 41% was water. How much sugar and how much water was there in a 16-ounce bottle of Coca-Cola?

FICO scores are the credit scores most lenders use to determine your credit risk. The higher your FICO® scores, the less you pay to buy on credit. The average (mean) FICO score is 723. The percents shown are based on the importance of the five categories for the general population.

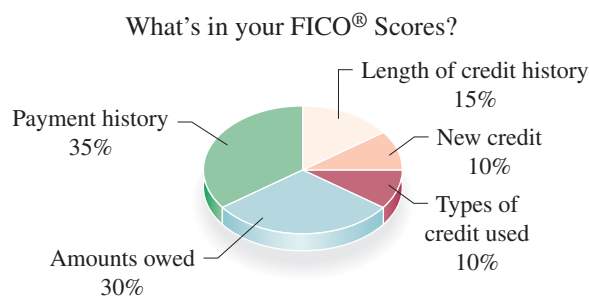

Source: <http://www.myfico.com/>.

FICO scores In Problems 71–74, find your FICO (Fair Isaac Company) score if

- Your length of credit history accounted for 108 points on the score.
- Your new credits accounted for 70 points on the score.
- The amounts owed accounted for 213 points on the score.
- Your payment history accounted for 262.5 points on the score.

Using Your Knowledge

Credit In many cases it is necessary to borrow money to expand your purchasing power. To use this money you pay a fee called a **finance charge**. Let us assume you wish to borrow \$100, to be repaid at \$25 per month plus interest of 1.5% per month on the *unpaid* balance. (The unpaid balance the first month is \$100, the second month, \$100 - \$25 = \$75, and so on.) Here is what you pay:

	Interest	Total Payment
Month 1	$0.015 \times 100 = \$1.50$	$25 + 1.50 = \$26.50$
Month 2	$0.015 \times 75 \approx 1.13$	$25 + 1.13 = 26.13$
Month 3	$0.015 \times 50 = 0.75$	$25 + 0.75 = 25.75$
Month 4	$0.015 \times 25 \approx 0.38$	$25 + 0.38 = 25.38$
		Total Payment $\$103.76$

Thus, the loan company might set up four equal payments of \$25.94 per month. Note that you have paid \$3.76 (\$103.76 - \$100) on the \$100 for 4 months.

- 75.** Suppose a bank lends you \$200 to be repaid at \$50 per month plus interest at 3% of the unpaid balance. What is the total interest you pay? (*Hint: It is not \$6.*)
- 76.** If the loan is to be paid in four equal payments, how much would your payments be per month?
- 77.** What percent of the \$200 is the total interest?
- 78.** Which loan is better, this one or another loan charging 15% annually?

The following credit cost table may help you to make decisions about loans and even save you some money in the future. Use the knowledge you gain from it.

Credit Cost Table Here is a summary of the current costs of various types of credit generally available, together with recommendations concerning each.

Type of Credit	Usual Cost Rate per Annum	Recommendation
College education loans qualifying for federal subsidy	3%	Great if you can get that rate!
College education loans with state or private guarantee, or with security, but without subsidy	7%	OK for good students.
First-mortgage home loans, open-end monthly payment plan	$4\frac{1}{2}$ to 12%	Good for most families with permanent, stable employment. Will clear the home from debt in 20 years or less, for rent money.
Unsecured home improvement loans from S. & L. assn's and banks	10 to 12%	Better than first-mortgage refinancing for major improvements to homes with old, low-rate mortgage that will not secure advances. Otherwise not recommended except in cases of extreme need.
Credit union loans	6 to 14%	Cheapest and most satisfactory form of small credit and auto financing.
Revolving credit plans of retail stores, including bank charge card plans	18 to 22%	OK, if you <i>must</i> ; check for specials and offers. But use them sparingly.
30-day retail credit, any plan, including charge cards	None if paid in 30 days	OK for convenience, if the price of the goods is right and you <i>know</i> you can pay the bill when it comes. But check prices against cash stores.
Automobile loans	5% and up	Beware the high cost of required insurance. Better drive the old car until you save enough money to trade up with cash.

Type of Credit	Usual Cost Rate per Annum	Recommendation
Appliance loans	18% and up	Cash will usually buy it for 20% to 30% less. Save and shop!
Personal loans—confidential—no questions asked	30% and up	Not recommended.
Loans from friends, relatives, or employers	?	Not recommended.
Payday loans, loan sharks, unlicensed	The sky's the limit	No!!!

>>> Write On

79. How many basic types of percent problems are there? Explain the procedure you use to solve each type.
80. Write in your own words the difference between *percent* and *percentage*.

>>> Concept Checker

Fill in the blank(s) with the correct word(s), phrase, or mathematical statement.

81. When working percent problems, the _____ is the **standard** used for **comparison** purposes. **number** **percentage**
82. The **part** being compared to the **base** or **total** is called the _____. **base** %
83. The **part** indicating the **ratio** of the **percentage** to the **base** is the _____. **percent**
84. The **percent** is usually written using the symbol _____ but the **percentage** is a _____.

>>> Mastery Test

85. The tuition and fees at a college are \$1500. If financial aid pays for 53% of the tuition and fees, how much is paid by financial aid? How much do you have to pay?
86. The sales tax on an item was \$1.48. If the tax rate is 8%, what was the price of the item?
87. 20 is 40% of what number?
88. A bicycle costs \$126. If the \$126 price includes a 30% discount, what was the original price of the bicycle?
89. Find $33\frac{1}{3}\%$ of 180.
90. What percent of 40 is 10?
91. Find $12\frac{1}{2}\%$ of 160.
92. 60% of 90 is what number?

>>> Skill Checker

Solve the following proportions.

93. $\frac{20}{100} = \frac{n}{80}$ 94. $\frac{P}{100} = \frac{30}{90}$ 95. $\frac{40}{100} = \frac{20}{W}$ 96. $\frac{30}{100} = \frac{60}{n}$

5.3

Solving Percent Problems Using Proportions

▶ Objectives

You should be able to:

- A** > Find the percentage when the base and rate are given.
- B** > Find the percent when the base and percentage are given.
- C** > Find the base when the percentage and percent are given.

▶ To Succeed, Review How To . . .

1. Write a percent as a fraction. (pp. 308–309)
2. Solve proportions. (pp. 284–285)

▶ Getting Started

25% Off the Slides (Sandals)

The slides are on sale for 25% off. 25% can be written as the ratio of 25 to 100, that is, $\frac{25}{100}$.

The ratios 1 to 4, 50 to 200, and 75 to 300 are all equivalent to the ratio 25 to 100, that is,

$$\frac{\text{Percent}}{100} \begin{array}{l} \longrightarrow \\ \longrightarrow \end{array} \frac{25}{100} = \frac{1}{4} = \frac{50}{200} = \frac{75}{300} \begin{array}{l} \longleftarrow \\ \longleftarrow \end{array} \frac{\text{Part}}{\text{Whole}}$$

We will study how to solve percent problems using proportions in this section.

Entire Stock of
ADIDAS SLIDES



Buy Online

A > Finding the Percentage Using Proportions

To solve percent problems using proportions, we proceed by steps:

- Step 1.** Write the percent ratio as the fraction $\frac{\text{Percent}}{100}$
- Step 2.** Write a second ratio as $\frac{\text{Part}}{\text{Whole}}$
- Step 3.** Set up the proportion $\frac{\text{Percent}}{100} = \frac{\text{Part}}{\text{Whole}}$

PERCENT:

PART:

WHOLE:

The number with the percent sign (%)

The number with the word *is* (numerator)

The number with the word *of* (denominator)

As in Section 5.2, there are three types of problems:

1. Finding the percentage (Part)
2. Finding the percent
3. Finding the base or total (Whole)

EXAMPLE 1 Finding the percentage using a proportion

What is 20% of 80?

Note: The question can be written equivalently as

Find 20% of 80, or

20% of 80 is what number?

SOLUTION 1 We solve using the three steps suggested:

Step 1. Write the percent ratio as the fraction $\frac{20}{100}$

Step 2. Write the second ratio as $\frac{\text{Part}}{\text{Whole}}$

Note that the number with the word *of* is 80, so 80 goes in the denominator. If we let n be the part, the second ratio is $\frac{n}{80}$.

Step 3. Set up the proportion $\frac{20}{100} = \frac{n}{80}$

To solve the proportion:

1. Cross multiply. $20 \times 80 = 100 \times n$

2. Divide by 100. $\frac{20 \times 80}{100} = n$

3. Simplify. $\frac{1600}{100} = 16 = n$

Thus, 20% of 80 is 16.

Verification: 20% of 80 = 0.20×80 , which is indeed 16.

PROBLEM 1

30% of 90 is what number?

B > Finding the Percent Using Proportions**EXAMPLE 2** Finding the percent of a number using proportions

30 is what percent of 90?

Note: The question can be written equivalently as:

Find what percent of 90 is 30.

What percent of 90 is 30?

SOLUTION 2 We solve using the three steps suggested:

Step 1. Write the percent ratio as the fraction $\frac{\text{Percent}}{100}$

Step 2. Write the second ratio as $\frac{\text{Part}}{\text{Whole}}$

Note that the number with the word *of* is 90. It is the whole, so 90 goes in the denominator.

30 appears with the word *is*. It is the numerator. So the second ratio is $\frac{30}{90}$.

Step 3. Set up the proportion $\frac{\text{Percent}}{100} = \frac{30}{90}$

To solve the proportion:

1. Cross multiply. $\text{Percent} \times 90 = 100 \times 30$

2. Divide by 90. $\text{Percent} = \frac{100 \times 30}{90}$

3. Simplify. $\text{Percent} = \frac{100}{3} = 33\frac{1}{3}$

Thus, 30 is $33\frac{1}{3}\%$ of 90.

Verification: $33\frac{1}{3}\%$ of 90 = $\frac{1}{3} \times 90$, which is indeed 30.

PROBLEM 2

Find what percent of 45 is 15.

Answers to PROBLEMS

1. 27 2. $33\frac{1}{3}\%$

C > Finding the Base Using Proportions

EXAMPLE 3 Finding the base or total using proportions

Find a number so that 40% of it is 20.

Note: The question can be written equivalently as:

20 is 40% of what number?

40% of what number is 20?

SOLUTION 3 We solve using the three steps suggested:

Step 1. Write the percent ratio as the fraction $\frac{40}{100}$

Step 2. Write the second ratio as $\frac{\text{Part}}{\text{Whole}}$

Since 20 appears next to the word *is*, 20 is the numerator.

The second ratio is $\frac{20}{\text{Whole}}$.

Step 3. Set up the proportion $\frac{40}{100} = \frac{20}{\text{Whole}}$

To solve the proportion:

1. Cross multiply. $40 \times \text{Whole} = 100 \times 20$

2. Divide by 40. $\text{Whole} = \frac{100 \times 20}{40}$

3. Simplify. $\text{Whole} = \frac{2000}{40} = 50$

Thus, we found a number (50) so that 40% of it is 20.

Verification: 40% of 50 = 0.40×50 , which is indeed 20.

PROBLEM 3

50 is 40% of what number?

Do you know what the Kyoto Protocol is? It is an international **agreement** linked to the United Nations Framework Convention on Climate Change setting targets for the industrialized countries and the European community for reducing greenhouse gas (GHG) emissions by 5.2% compared to the year 1990. The United States has neither withdrawn nor approved the protocol but has been assigned a target of 93. We will see what that means in Example 4.

GREEN MATH

EXAMPLE 4 Percents and the Kyoto Protocol

The 93 target assigned to the United States by the Kyoto Protocol means that the United States will try to limit GHG emissions to 93% of the emissions in 1990. If the United States had 6100 MMT of CO₂e* in 1990, how many MMTs is the 93% target?

SOLUTION 4 We are looking for 93% of 6100, so follow the steps of Example 1.

Step 1. Write the percent as a fraction: $\frac{93}{100}$

Step 2. Write the second ratio as $\frac{\text{Part}}{\text{Whole}}$ and note that the number with the word “of” is 6100, so the 6100 goes in the denominator. If we let t be the part, the second ratio is $\frac{t}{6100}$.

Step 3. Set up the proportion $\frac{93}{100} = \frac{t}{6100}$

PROBLEM 4

Suppose the United States will limit itself to producing 93% of the **world** emissions of GHG in 1990: about 8300 MMT of CO₂e. How many MMTCO₂e is that?

Answers to PROBLEMS

3. 125 4. 7719 MMTCO₂e

To solve the proportion:

1. Cross multiply $93 \times 6100 = 100t$

2. Divide by 100 $\frac{93 \times 6100}{100} = t$

3. Simplify $93 \times 61 = 5673 = t$

Thus, 93% of 6100 is 5673, which means that the United States should limit its emissions to 5673 MMT of CO₂.

*MMTCO₂e means a Million Metric Tons of CO₂ equivalent. One metric ton is 2210 pounds and One MMTCO₂ is equivalent to removing 185,000 cars from the road!

Data Source: <http://tinyurl.com/qmn47m>.

> Exercises 5.3



> Practice Problems > Self-Tests
> Media-rich eBooks > e-Professors > Videos

< A > Finding the Percentage Using Proportions In Problems 1–14, find the percentage using proportions.

- | | | |
|--------------------------------------|------------------------------------|--------------------------------------|
| 1. Find 30% of 80. | 2. Find 15% of 80. | 3. 150% of 20 is what number? |
| 4. 25% of 60 is what number? | 5. What is 20% of \$30? | 6. What is 95% of 80? |
| 7. Find 60% of 45. | 8. Find 120% of \$40. | 9. $12\frac{1}{2}\%$ of 60 is _____. |
| 10. $8\frac{1}{4}\%$ of 60 is _____. | 11. 3.5% of 60 is _____. | 12. 110.5% of 80 is _____. |
| 13. Find $16\frac{2}{3}\%$ of 132. | 14. Find $83\frac{1}{3}\%$ of 102. | |

< B > Finding the Percent Using Proportions In Problems 15–32, find the percent using proportions.

- | | | |
|---|---------------------------------------|---|
| 15. 325 is what percent of 3250? | 16. 15 is what percent of 90? | 17. 16 is what percent of 4? |
| 18. 7 is what percent of 28? | 19. Find what percent of 50 is 10. | 20. Find what percent of 40 is 8. |
| 21. What percent of 40 is 8? | 22. What percent of 25 is 10? | 23. $6\frac{1}{2}$ is what percent of 26? |
| 24. $2\frac{1}{4}$ is what percent of 27? | 25. 4 is _____ % of 5. | 26. 20 is _____ % of 40. |
| 27. 50 is _____ % of 25. | 28. 45 is _____ % of $7\frac{1}{2}$. | 29. \$50 is _____ % of \$60. |
| 30. \$90 is _____ % of \$3600. | 31. \$0.75 is _____ % of \$4.50. | 32. \$0.25 is _____ % of \$1.50. |

< C > Finding the Base Using Proportions In Problems 33–54, find the base using proportions.

- | | |
|--|--|
| 33. 30% of what number is 90? | 34. 15% of what number is 60? |
| 35. $2\frac{1}{4}\%$ of what number is 18? | 36. $5\frac{1}{2}\%$ of what number is 22? |
| 37. 60 is 40% of what number? | 38. 30 is 150% of what number? |
| 39. 30 is $33\frac{1}{3}\%$ of a number. Find the number. | 40. 20 is $66\frac{2}{3}\%$ of a number. Find the number. |
| 41. Find a number so that 120% of it is 42. | 42. Find a number so that $3\frac{1}{4}\%$ of it is $6\frac{1}{2}$. |
| 43. 40% of what number is $7\frac{1}{2}$? | 44. 140% of what number is 70? |
| 45. 4.75% of what number is 76? | 46. 3.25% of what number is 78? |
| 47. 100% of what number is 49? | 48. 8% of what number is 3.2? |
| 49. $12\frac{1}{2}\%$ of what number is 37.5? | 50. $33\frac{1}{3}\%$ of what number is $66\frac{2}{3}$? |
| 51. $16\frac{2}{3}\%$ of what number is 8? | 52. $66\frac{2}{3}\%$ of what number is $33\frac{1}{3}$? |
| 53. 50 is $62\frac{1}{2}\%$ of a number; what is the number? | 54. 60 is $37\frac{1}{2}\%$ of a number; what is the number? |

>>> Applications: Green Math

In Exercises 55–58, follow the procedure of Example 4 and set up and solve a proportion to find the target emission for each country, given that the emission reduction commitment for 1990 was as shown in column 3.

Country	Reduction Commitment	1990 Emissions (in MMTs)
55. Canada	94	460
56. United Kingdom	92	600
57. Australia	108	280
58. Norway	101	34

>>> Using Your Knowledge

Cardiac Health How can you measure your cardiac health? By looking at the ratio $\frac{w}{h}$, where w is your waist size and h is your hip size.

For women: If $\frac{w}{h} > \frac{8}{10}$, the risk of heart disease increases.

For men: If $\frac{w}{h} > 1$, the risk of heart disease increases.

59. A woman has a 24-inch waist. What h (hip size) will make her risk of heart disease increase?
(Hint: Solve $\frac{24}{h} > \frac{8}{10}$ as a proportion.)
60. A woman has a 30-inch waist. What h (hip size) will make her risk of heart disease increase?
61. A man has a 32-inch waist. What h (hip size) will make his risk of heart disease increase?
(Hint: Solve $\frac{32}{h} > 1$ as a proportion.)
62. A man has a 40-inch waist. What h (hip size) will make his risk of heart disease increase?

>>> Write On

63. Which method would you use to solve percent problems: the method used in Section 5.2 or proportions? Explain why.
64. In Section 5.2, we have the formula $P = R \times B$. If the rate is written as a fraction with a denominator of 100, explain how you can derive the proportion $\frac{\text{Percent}}{100} = \frac{\text{Part}}{\text{Whole}}$ from $P = R \times B$.

>>> Concept Checker

Fill in the blank(s) with the correct word(s), phrase, or mathematical statement.

65. To solve percent problems using **proportions**, we first write the **percent ratio** as the **fraction** _____.
66. To solve percent problems using **proportions**, we set up the **proportion** $\frac{\text{Percent}}{100} = \frac{\text{Part}}{\text{Percent}}$ _____.

Percent
100
Percent
Part
Percent

>>> Mastery Test

67. Set up a proportion and solve: What is 40% of 80?
68. Set up a proportion and solve: 30 is what percent of 40?
69. Set up a proportion and solve: $3\frac{1}{2}\%$ of what number is 21?

>>> Skill Checker

Write as a decimal.

70. $66\frac{2}{3}\%$

71. $5\frac{1}{2}\%$

72. $8\frac{1}{4}\%$

73. $16\frac{2}{3}\%$

74. $33\frac{1}{3}\%$

5.4

Taxes, Interest, Commissions, and Discounts

▶ Objectives

You should be able to:

- A** > Find the sales tax and the total cost of an item.
- B** > Find the simple interest in a transaction.
- C** > Find the compound interest in a transaction.
- D** > Find the commission on a sale.
- E** > Find the discount and the sale price of an item.
- F** > Solve applications involving percents.

▶ To Succeed, Review How To . . .

1. Find a percent of a number. (pp. 318–319, 329)
2. Round to the nearest cent. (pp. 226–227)

▶ Getting Started

The man in the cartoon is ruined by taxes. A tax is an amount of money collected by the government and calculated as a percent of some total amount.



© The New Yorker Collection 1951 Piet Hein from cartoonbank.com. All Rights Reserved.

A > Sales Tax

The **sales tax** in a city in Alabama is 4%, which means that if you buy an item costing \$60, the tax would be

$$\begin{array}{c} 4\% \text{ of } \$60 \\ \downarrow \downarrow \downarrow \\ 0.04 \times \$60 = \$2.40 \end{array}$$

That is, the tax is **\$2.40**.

In general, the sales tax is equal to the product of the sales tax rate and the list price.

SALES TAX

$$\text{Sales Tax} = \text{Sales Tax Rate} \times \text{List Price}$$

Since the sales tax is always added to the buyer's cost, the total cost of the item is given by the sum of the list price and the sales tax.

TOTAL COST

$$\text{Total cost} = \text{List price} + \text{Sales tax}$$

$$\begin{aligned} \text{Thus, total cost} &= \$60 + \$2.40 \\ &= \$62.40 \end{aligned}$$

EXAMPLE 1 Finding the sales tax
The sales tax in Florida is 6%. How much would you pay for a pair of slacks costing \$18.50?

SOLUTION 1 Since

$$\begin{array}{c} 6\% \text{ of } 18.50 \\ \downarrow \quad \downarrow \quad \downarrow \\ 0.06 \times 18.50 = 1.1100 \end{array}$$

The total cost is $\$18.50 + \$1.11 = \$19.61$.



PROBLEM 1
If the sales tax is 5%, how much would you pay for a pair of shoes costing \$33?

B > Simple Interest



The idea of *percent* is also used in banking. For example, if you deposit \$300 in a bank paying $5\frac{1}{4}\%$ annually on the amount deposited, then your **simple interest** (the amount the bank pays you for using your money) at the end of the year is computed by using the formula

$$I = P \times R \times T$$

\uparrow \uparrow \uparrow
 simple interest principal rate time

In our example,

$$I = 300 \times 5\frac{1}{4}\% \times 1$$

\uparrow \uparrow \uparrow
 principal interest rate time
 (amount deposited) per year (years)

Thus,

$$I = \$300 \times 0.0525 \times 1 = \$15.7500 = \$15.75$$

Of course, you can use the same idea to *borrow* money from the bank. For example, if you borrow \$600 at 12% annual interest for 4 months, the interest you have to pay is

$$\begin{aligned} I &= P \times R \times T \\ I &= \$600 \times 12\% \times \frac{4}{12} \\ &= \$600 \times 0.12 \times \frac{1}{3} \\ &= \$24 \end{aligned}$$

← Note that the time must be in years and 4 months is $\frac{4}{12}$ or $\frac{1}{3}$ of a year.

Answers to PROBLEMS

1. \$34.65

EXAMPLE 2 Finding the simple interest I

Find the simple interest earned on \$1600 invested at 9.5% annual rate for 3 months.

SOLUTION 2

$$\begin{aligned}
 I &= P \times R \times T = \$1600 \times 9.5\% \times \frac{1}{4} \quad \text{3 months is } \frac{3}{12} = \frac{1}{4} \text{ year.} \\
 &= \$1600 \times 0.095 \times \frac{1}{4} = \mathbf{\$38}
 \end{aligned}$$

PROBLEM 2

Find the simple interest paid on \$1200 borrowed at 8.5% for 4 months.

C > Compound Interest

The process of computing interest on the earned interest is called compounding the interest. To illustrate the difference between simple and compound interest, suppose you invest \$100 for one year at 7% simple interest. At the end of the year, your interest will be $I = PRT$, where $P = \$100$, $R = 7\% = 0.07$, and $T = 1$, or $I = 100 \times 0.07 \times 1 = \7 .

Now, suppose you invest the same \$100 at 7% compounded quarterly (four times a year). Although the annual rate is $7\% = 0.07$, the time is $\frac{1}{4}$ of a year, so that the rate each quarter is $\frac{7\%}{4} = 0.0175$. The compound interest calculation for each quarter is as follows.

$$\begin{array}{r}
 \$100 \quad \text{Principal} \\
 \times \quad 0.0175 \quad \text{Rate per quarter} \\
 \hline
 \$1.75 \quad \text{Interest (1st quarter)} \\
 \\
 \$101.75 \quad \text{Principal } (\$100 + \$1.75) \\
 \times \quad 0.0175 \quad \text{Rate per quarter} \\
 \hline
 \$1.780625 \quad \text{Interest (2nd quarter)} \\
 \\
 \$103.53 \quad \text{Principal } (\$101.75 + 1.78) \\
 \times \quad 0.0175 \quad \text{Rate per quarter} \\
 \hline
 \$1.811775 \quad \text{Interest (3rd quarter)} \\
 \\
 \$105.34 \quad \text{Principal } (\$103.53 + \$1.81) \\
 \times \quad 0.0175 \quad \text{Rate per quarter} \\
 \hline
 \$1.84345 \quad \text{Interest (4th quarter)}
 \end{array}$$

Thus, the total compound interest for the four quarters is
 $\$1.75 + \$1.78 + \$1.81 + \$1.84 \approx \mathbf{\$7.18}$.

EXAMPLE 3 Finding the compound interest

Find the total compound interest and the final compound amount for \$100 invested at 8% compounded semiannually (twice a year) for 2 years.

SOLUTION 3 Here $P = \$100$, $r = 8\%$, and the semiannual rate is $\frac{8\%}{2} = 4\% = 0.04$.

$$\begin{array}{r}
 \$100 \quad \text{Principal} \\
 \times \quad 0.04 \quad \text{Semiannual rate} \\
 \hline
 \$4.00 \quad \text{Interest (1st 6 months)} \\
 \\
 \$104 \quad \text{Principal } (\$100 + \$4) \\
 \times \quad 0.04 \quad \text{Semiannual rate} \\
 \hline
 \$4.16 \quad \text{Interest (2nd 6 months)} \\
 \\
 \$108.16 \quad \text{Principal } (\$104 + \$4.16) \\
 \times \quad 0.04 \quad \text{Semiannual rate} \\
 \hline
 \$4.3264 \quad \text{Interest (3rd 6 months)} \\
 \\
 \$112.49 \quad \text{Principal } (\$108.16 + \$4.33) \\
 \times \quad 0.04 \quad \text{Semiannual rate} \\
 \hline
 \$4.4996 \quad \text{Interest (4th 6 months)}
 \end{array}$$

The total compound interest is $\$4 + \$4.16 + \$4.33 + \$4.50 = \$16.99$, and the final compound amount is $\$100 + \$16.99 = \mathbf{\$116.99}$.

PROBLEM 3

Find the total compound interest and the final compound amount for \$100 invested at 6% compounded semiannually for 2 years.

Answers to PROBLEMS

2. \$34 3. \$12.55; \$112.55

In Example 3, we multiplied the principal P by the rate per period. The rate per period i is defined as follows:

Rate per period i

$$i = \frac{\text{Nominal rate}}{\text{Number of periods per year}}$$

Thus, 8% compounded semiannually yields $i = \frac{8\%}{2} = 4\%$ per period.

The computations in Example 3 can be shortened if we use the following formula to find the compound amount A .

Compound amount A

$$A = P(1 + i)^n$$

In this formula, A is the compound amount, P is the principal, i is the rate per period, and n is the number of periods.

Here is the derivation. Let I be the compound interest, P be the original principal, i be the rate per period, and A_1 be the compound amount at the end of the first period.

$$I = Pi \quad \text{Interest for the first period}$$

$$A_1 = P + I$$

$$= P + Pi \quad \text{Substitute } Pi \text{ for } I.$$

$$= P(1 + i) \quad \text{Use the distributive property.}$$

After the end of the second period, the compound amount A_2 is

$$A_2 = A_1 + A_1 i$$

$$= A_1(1 + i) \quad \text{Use the distributive property.}$$

$$= P(1 + i)(1 + i) \quad \text{Substitute } P(1 + i) \text{ for } A_1.$$

$$= P(1 + i)^2 \quad \text{Substitute } (1 + i)^2 \text{ for } (1 + i)(1 + i)$$

If we continue this procedure, after n periods A_n will be $A_n = P(1 + i)^n$.

FORMULA FOR THE COMPOUND AMOUNT A

The compound amount A for a rate i per period applied to a principal P for n periods is given by

$$A = P(1 + i)^n$$

Now let's solve Example 3 using this formula. Thus, $P = \$100$, $i = \frac{8\%}{2} = 4\%$ or 0.04, and $n = 2 \times 2 = 4$ (2 years, semiannually).

$$\begin{aligned} A &= \$100(1 + 0.04)^4 = \$100(1.04)^4 \\ &= \$100 \times 1.16985856 \approx \$116.99 \end{aligned}$$

EXAMPLE 4 Finding the compound amount using the formula

Find the compound amount and the compound interest when \$5000 is invested at 6% compounded semiannually for 3 years.

SOLUTION 4 Here $P = \$5000$, $i = \frac{6\%}{2} = 3\% = 0.03$, and $n = 6$ periods.

$$\begin{aligned} A &= \$5000(1 + 0.03)^6 \\ &= \$5000(1.03)^6 \\ &= \$5000 \times (1.03 \times 1.03 \times 1.03 \times 1.03 \times 1.03 \times 1.03) \\ &\approx \$5000(1.19405230) \\ &\approx \$5970.26 \end{aligned}$$

The compound interest $I = A - P = \$5970.26 - \$5000 = \$970.26$.

PROBLEM 4

Find the compound amount and the interest when \$10,000 is invested at 8% compounded semiannually for 2 years.

Answers to PROBLEMS

4. \$11,698.59; \$1698.59



D > Commissions

Percents are also used as incentives for obtaining more sales from salespersons. This is done by giving salespeople a share of the sales, called a **commission**. This commission is stated as a percent of the sales income. In Florida, for example, real estate people receive a 7% commission on each sale. Thus, if they sell a house valued at \$95,000, the commission is

$$\begin{array}{l} 7\% \text{ of } \$95,000 \\ \downarrow \quad \downarrow \quad \downarrow \\ 0.07 \times \$95,000 = \$6650 \end{array}$$

In general, the commission is equal to the product of the commission rate and the sale price.

COMMISSION

$$\text{Commission} = \text{Commission Rate} \times \text{Sale Price}$$

EXAMPLE 5 Finding commissions

The Move-and-Go Car Lot pays salespeople an 8% commission on their sales. What would the commission be on the sale of a used car costing \$2499.95?

SOLUTION 5 The commission is 8% of \$2499.95:

$$0.08 \times \$2499.95 = \$199.9960$$

If we round \$199.9960, we find the commission to be **\$200**.

PROBLEM 5

Find the commission on a \$1599.95 sale if the commission rate is 6%.

E > Discounts

As we have mentioned before, percents are used to attract buyers to stores. A sale at “20% off,” that is, a **discount** of 20%, means that regular prices have been *reduced* by $20\% = \frac{20}{100} = \frac{1}{5}$. Thus, if the **regular**, or **list**, price of an article is \$50 and the article is offered on sale at a 20% discount, the *discount* is

$$\begin{array}{l} 20\% \text{ of } \$50 \\ \downarrow \quad \downarrow \quad \downarrow \\ 0.20 \times \$50 = \$10.00 \end{array}$$

$$\begin{array}{l} \text{Sale price} = \text{Regular price} - \text{Discount} \\ = \$50 - \$10 = \$40 \end{array}$$

Thus, the sale price of the article is **\$40**.

EXAMPLE 6 Finding discount and sale price

Find the discount and the sale price of an article regularly selling for \$12.50, which is being advertised at 10% off.

SOLUTION 6 The discount is 10% of \$12.50:

$$0.10 \times \$12.50 = \$1.25$$

Thus, the sale price is $\$12.50 - \$1.25 = \mathbf{\$11.25}$.

PROBLEM 6

Find the discount and sale price of an \$8.50 article selling at 20% off.

Answers to PROBLEMS

5. \$96 6. Discount: \$1.70; sale price: \$6.80

F > Applications Involving Percents

Do you know what the letters in the word *tips* stand for? They stand for “to insure prompt service.” At restaurants, diners tip anywhere from 10% to 25% of the total bill. We illustrate how to figure the tip next.

EXAMPLE 7 Calculating the tip

The total bill for a meal comes to \$38.50. If you want to leave a 15% tip, how much tip should you leave?

SOLUTION 7 We have to find 15% of 38.50.

$$\begin{aligned} 0.15 \times \$38.50 &= \$5.775 \\ &= \mathbf{\$5.78} \quad (\text{To the nearest cent}) \end{aligned}$$

(For practical reasons, you would probably leave a \$5.75 or a \$6 tip.)

PROBLEM 7

The total bill for a meal is \$60.70. If you want to tip 20%, how much should the tip be? (Answer to the nearest cent.)

Do you remember the solar panels we discussed in Example 10, Section 2.3? You get a tax **credit** if you install a qualified solar water heater or a photovoltaic (solar) system used to produce electricity (Energy Act of 2008). How much tax credit do you get? See Example 8.

GREEN MATH

EXAMPLE 8 Solar Tax Credits

The Energy Act of 2008 gives homeowners a 30% credit of the cost of a solar electric system. How much is your credit if you buy a \$40,000, 5-kilowatt rooftop system?

SOLUTION 8 We need to find 30% of \$40,000, that is, $0.30 \times 40,000 = 12,000$. Thus, the tax credit will be **\$12,000**.

PROBLEM 8

The law also provides for a 30% credit on the installed cost of a small (less than 100 kilowatts) wind turbine. Suppose you pay \$12,000 for a qualifying small wind turbine. How much is the credit?

Note: Unfortunately, there is a \$4000 cap on this deduction!



Calculator Corner

A calculator is very convenient when doing taxes, interest, commissions, and discounts. Let us take each of the problems separately. For example, to solve Example 1: Find how much you have to pay for a pair of pants costing \$18.50 if the tax is 6% by simply pressing **1 8 . 5 0 + 6 % ENTER**. The final answer, \$19.61, will be displayed.

If your calculator does not have a % key, you may have to use the **store** **[M+]** and **recall** **[MR]** keys. As their names imply, these keys *store* numbers in their memory and then *recall* them. Suppose you wish to solve Example 1 with a calculator. You press **1 8 . 5 0 [M+] × 0 . 0 6 ENTER**. Here the calculator has **stored** the 18.50 and taken 6% of 18.50. The display shows 1.11. Now, press **+ [MR] ENTER** and the calculator will add the number stored (18.50) to the 1.11, giving you \$19.61, as before.

If your calculator has a **power key** (a **y^x** key), then the quantity $(1.03)^6$ appearing in Example 4 can be obtained as follows: **1 . 0 3 [y^x] 6 ENTER**. You will get 1.19405230.

Answers to PROBLEMS

7. \$12.14 8. \$3600

> Exercises 5.4



> Practice Problems > Self-Tests
> Media-rich eBooks > e-Professors > Videos

< A > Sales Tax In Problems 1–8, solve the problems involving sales tax.

- The retail sales tax in Alabama is 4%. Find the total cost of a \$3500 used car.
- The retail sales tax in Florida is 6%. Find the total cost of a lamp selling for \$15.50.
- The retail sales tax in Georgia is 4%. What is the total cost of an item selling for \$12.50?
- One of the most expensive cars ever built, the Presidential Lincoln Continental Executive, cost \$500,000. If a 7% excise tax had to be paid when buying this car, what was the tax on the car?
- The sales tax on a car was \$150, and the sales tax rate was 5%. What was the purchase price of the car before taxes?
- A man paid \$3520 in income taxes. His annual salary is \$16,000. What percent of his income went for taxes?

< B > Simple Interest In Problems 9–16, find the simple interest.

	Principal	Annual Rate of Interest	Time
9.	\$200	12%	1 year
10.	\$250	16%	3 years
11.	\$400	15%	$\frac{1}{2}$ year
12.	\$1200	9%	3 months
13.	\$1500	15%	2 months
14.	\$900	13%	4 months
15.	\$300	9%	60 days*
16.	\$900	16%	30 days*

* Assume a year has 360 days.

- In one year the highest bank interest rate was that of Brazil at 106%.
 - How much simple interest would you earn if you deposited \$500 for one year at this rate?
 - How much simple interest would you pay on a two-year, \$2500 loan using the 106% rate?
- The funds rate (interest that banks charge each other) was at a 46-year low of 1% in June 2004.
 - How much simple interest would you earn if you deposited \$600 for one year at this rate?
 - How much simple interest would you pay on a two-year, \$4000 loan at the 1% rate?
- Ms. Garcia had a \$1000 bond paying 8% annual interest. How much simple interest did she receive in two years?
- Mr. Liang borrowed \$150 at 10% interest for 2 years. How much simple interest did he pay?

< C > Compound Interest In Problems 21–25, use the compound interest formula, $A = P(1 + i)^n$.

- A small computer software company invests \$5000 at 10% compounded semiannually for 2 years. What will the compound amount be at the end of this period?
- Douglas Thornton invested \$50,000 at 10% compounded semiannually for a period of 2 years. What amount should he receive at the end of the 2 years?
- Jorge Riopedre bought a \$500 certificate of deposit on May 1. If the certificate paid 12% interest compounded monthly, what was his balance July 1?
- A 3-year, \$1000 certificate of deposit yields 12% interest compounded annually. How much money will it be worth at the end of the 3 years?
- Maria Rodriguez deposited \$1000 in her account April 1. The bank paid 6% interest compounded monthly.
 - What was her balance June 1?
 - On June 1, Maria made a deposit and her new balance was \$1500. How much was her deposit?

< D > Commissions In Problems 26–30, solve the commission problems.

- Howard Hues, a paint salesperson, earns a 10% commission rate. What is his commission if he sells \$4800 worth of paint?
- Dan Driver, a car salesperson, earns an 8% commission rate. How much commission money did he get when he sold a \$3500 car?

- 28.** Connie Dominion, a real estate agent, sells a house for \$37,000. Her commission rate is 3.5%. How much is her commission?
- 30.** One of the highest-priced diamonds ever sold at an auction was bought by Cartier of New York for \$1,050,000. If the salesperson got a 2% commission, how much was her commission?
- 29.** Toy Auto Sales pays their salespersons \$500 a month plus a 2% commission on each sale. If a person sold only one car for \$6300, what was that person's total salary for the month?

< E > Discounts In Problems 31–35, solve the problems involving discounts.

- 31.** An article regularly sells for \$14.50. It is on sale at 10% off. How much do you have to pay for it now?
- 33.** A scratched refrigerator regularly priced at \$460 was sold at a 10% discount. What was its new price?
- 35.** An invoice for \$250 offers a 2% discount if paid within 60 days. How much is the discount?
- 32.** A lamp is offered on sale at 20% off its regular \$15 price. What is the sale price of the lamp?
- 34.** Mary Smith owed \$500 on her account. She paid off the whole amount, receiving a 3% discount for early payment. How much was the discount?

< F > Applications Involving Percents

- 36. Tipping** The total bill for a meal comes to \$30.40. If you decide to leave a 10% tip, how much should you leave? (Answer to the nearest cent.)
- 38. Tipping** A meal for two at a fancy restaurant comes to \$73.40. You decide to tip 15% and split the bill.
- How much is the tip?
 - To the nearest cent, how much should each person pay?
- 40. Tipping tips** Suppose your bill in a restaurant amounted to \$54. If you want to leave a 10% tip, you simply move the decimal point one place left in \$54, obtaining \$5.40: the tip.
- What is the tip if you want to leave 20%?
 - Since $20\% = 2 \times 10\%$, a quicker way will be to **double** the \$5.40. What is the tip then? Do you get the same answer as in part **a**?
- 42. Tipping tips** Suppose your dinner bill came to \$74. Fill in the blanks in the table with an expression that will calculate the tip, and then simplify the expression. Check by taking 10%, 15%, 20%, and 25% of \$74.

10% tip	
15% tip	
20% tip	
25% tip	

- 44. Tipping tips** Suppose your dinner bill was \$80 and a 7% tax was automatically added.
- What is the tax?
 - If you want to leave a 14% tip, how much money would you leave as a tip?
 - If you want to leave a 21% tip, how much money would you leave as a tip?
- 41. Tipping tips** You received good service and you are going to leave a 25% tip on your \$54 bill.
- What is the tip?
 - Is there a shortcut to get the 25% tip? Of course! Double the 10% (the \$5.40) and then take half of it ($\frac{1}{2}$ of $10\% = 5\%$). Your tip is now $20\% + 5\%$ or 25%. Write an expression that would result in the 25% tip.
 - Simplify the expression that you created in part **b**. Do you get the same answer as in **a**?
- 43. Tipping tips** There is another tipping shortcut based on the tax added to the bill. For example, suppose the dinner bill was \$62 and a 6% tax was automatically added.
- What is the tax?
 - If you want to leave a 12% tip, how much money would you leave as a tip?
 - If you want to leave an 18% tip, how much money would you leave as a tip?
- 45. Tipping tips** Suppose your dinner bill was \$58 plus 8% tax.
- How much is the tax?
 - If you want to leave a 16% tip, how much money would you leave?
 - If you want to leave a 12% tip, how much money would you leave?

Applications: Green Math

The Energy Act of 2008 gives homeowners a 30% credit of the cost of a solar electric system and a 30% credit (up to \$4000) for the installed cost of a wind turbine.



- 46. What is the credit for a \$32,000 rooftop solar electric system?
- 47. What is the credit for a \$39,000 rooftop solar electric system?
- 48. What is the credit for a 9-kilowatt residential turbine costing \$36,000?
- 49. What is the credit for a 3-kilowatt residential turbine costing \$13,000?

Using Your Knowledge

Taxable Income Sooner or later (probably sooner) you will have to pay federal income taxes to the government. These taxes are paid on your **taxable income**, which is arrived at by following the steps in federal income tax Form 1040. After finding your taxable income, you may be required to use schedule Y-1.

Schedule Y-1— Married Filing Jointly or Qualifying Widow(er)	If Taxable Income		The Tax Is		
	Then				
	Is Over	But Not Over	This Amount	Plus This %	Of the Excess Over
	\$0	\$14,000	\$0.00	10%	\$0.00
	\$14,000	\$56,800	\$1,400.00	15%	\$14,000
	\$56,800	\$114,650	\$7,820.00	25%	\$56,800
	\$114,650	\$174,700	\$22,282.50	28%	\$114,650
	\$174,700	\$311,950	\$39,096.50	33%	\$174,700
	\$311,950	—	\$84,389.00	35%	\$311,950

To get the most current tax rates, go to <http://www.irs.gov>.

Suppose your taxable income is \$12,000. Your tax is 10% of this amount (first line, 0 to \$14,000):

$$0.10 \times \$12,000 = \$1200$$

If your taxable income is \$40,000, you fall between \$14,000 and \$56,800 (second line). Your tax is

$$\begin{aligned}
 & \$1400 + 15\% \text{ of the amount over } \$14,000 \\
 &= \$1400 + 0.15 \times (\$40,000 - \$14,000) \\
 &= \$1400 + 0.15 \times \$26,000 \\
 &= \$1400 + \$3900 \\
 &= \$5300
 \end{aligned}$$

Taxable Income In Problems 50–55, find the tax for each taxable income.

- 50. \$20,000
- 51. \$25,000
- 52. \$50,000
- 53. \$60,000
- 54. \$80,000
- 55. \$100,000

Write On

- 56. What are the three variables (factors) used when calculating simple interest?
- 57. Write in your own words which would be better for you: to take a 20% discount on an item, or to take 10% off and then 10% off the reduced price.

58. Which investment is better for you: \$10,000 invested at 5% compounded semiannually or \$10,000 invested at 4% compounded monthly? Explain why.
59. Most people give 10%, 15%, or 20% of the total bill as a tip. (See Problem 42.)
- In your own words, give a rule to find 10% of any amount. (*Hint:* It is a matter of moving the decimal point.)
 - Based on the rule in part **a**, state a rule that can be used to find 15% of any amount.
 - Based on the rule in part **a**, state a rule that can be used to find 20% of any amount.

>>> Concept Checker

Fill in the blank(s) with the correct word(s), phrase, or mathematical statement. The formula $A = P(1 + i)^n$ will be used in Problems 60–63.

60. In the formula, A represents the _____.
61. In the formula, P is the _____.
62. In the formula, i is the rate per _____.
63. The rate per period i is the quotient of the **nominal** rate and the **number of periods** per _____.
- | | |
|--------|-----------|
| month | interest |
| period | principal |
| amount | year |

>>> Mastery Test

64. The total bill for a meal is \$78.50. If you want to leave a 15% tip, how much money (to the nearest cent) should you leave as a tip?
65. Find the discount and the sale price of a book selling for \$80 and being advertised at 12% off.
66. Beverly is a real estate agent in Florida, and sold a house valued at \$105,000. If her commission rate is 7%, how much commission did she get?
67. Find the compound amount and the compound interest when \$10,000 is invested at 4% compounded semiannually for 2 years.
68. Find the simple interest paid on a 6%, 3-month, \$1200 loan.
69. The state sales tax in California is 7.25%. Find the total cost (price plus tax) of a pair of running shoes costing \$120.

>>> Skill Checker

In Problems 70–75, give the answer to the nearest percent.

70. What percent of 52 is 30?
71. What percent of 48 is 80?
72. Find what percent of 62 is 30.
73. Find what percent of 72 is 40.
74. 15 is what percent of 22?
75. 25 is what percent of 30?

5.5

Applications: Percent of Increase or Decrease

▶ Objectives

You should be able to:

- A** > Solve percent problems involving percent increase or decrease.
- B** > Solve applications involving percent increase or decrease.

▶ To Succeed, Review How To . . .

Find what percent of one number is another. (pp. 318–319, 329)

▶ Getting Started

Is your college tuition going up?

The chart shows the annual growth in tuition and fees at public four- and two-year colleges and at private four-year colleges. (blue line) What about public four-year colleges

(green line)? What was their **percent increase** for tuition and fees over the 30-year period from 78–79 to 08–09? We shall see next.

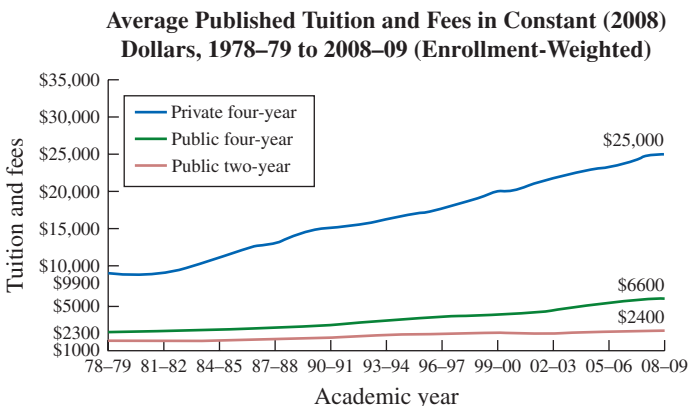

Source: <http://professionals.collegeboard.com/profdownload/trends-in-college-pricing-2008.pdf>.

▶ Percent of Increase or Decrease

To find the *percent increase* in public four-year schools (green line) over the 30-year period, we first look at the cost in 78–79 (\$2300) and the cost in 08–09 (\$6600).

The increase is $\$6600 - \$2300 = \$4300$

The **percent of increase** over 78–79 is

$$\frac{\text{Increase}}{\text{Over 78–79}} \rightarrow \frac{\$4300}{\$2300} = \frac{43}{23} \approx 186.95\%$$

$$\begin{array}{r} 1.8695 \\ 23 \overline{)43.0000} \\ \underline{-23} \\ 200 \\ \underline{-184} \\ 160 \\ \underline{-138} \\ 220 \\ \underline{-207} \\ 130 \\ \underline{-115} \\ 15 \end{array}$$

Can you follow this procedure and find the percent increase for private four-year schools?

Here is the rule we have used:

TO FIND A PERCENT OF INCREASE OR DECREASE

1. Find the *amount* of increase (or decrease).
2. Divide by the original amount.
3. Write the answer to step 2 as a percent.

EXAMPLE 1 Calculating percent increase

In a 4-year period, sneaker sales rose from \$1.8 billion to \$3 billion. Find the percent of increase to the nearest percent.

SOLUTION 1 We follow the three steps given:

Step 1. The amount of increase is

$$3.0 - 1.8 = 1.2$$

Step 2. The original amount is 1.8. We divide the amount of increase (1.2) by 1.8:

$$\begin{array}{r} 0.666 \\ 1.8 \overline{) 1.2000} \\ \underline{108} \\ 120 \\ \underline{108} \\ 120 \\ \underline{108} \\ 12 \end{array}$$

Step 3. Write 0.666 as 67%. Thus, the percent of increase was 67%.

PROBLEM 1

Last year sneaker sales went from \$3 billion to \$4.3 billion. Find the percent of increase to the nearest percent.

Percents of increase and decrease are used in business and other fields. For example, the Dow Jones Industrial Average (DJIA) tracks the prices of 30 leading stocks and is supposed to indicate trends for individual stocks. On October 19, 1987, the market had one of its largest percent drops ever. We calculate the percent of decrease in stock prices next.

EXAMPLE 2 Calculating percent decrease

On October 19, 1987, the DJIA went down from 2246 to 1738. To the nearest percent, what was the percent of decrease?

SOLUTION 2 As before, we use three steps:

Step 1. The *amount* of decrease is

$$2246 - 1738 = 508$$

Step 2. We divide the decrease (508) by the original amount (2246):

$$\begin{array}{r} 0.226 \\ 2246 \overline{) 508.000} \\ \underline{4492} \\ 5880 \\ \underline{4492} \\ 13880 \\ \underline{13476} \\ 404 \end{array}$$

Step 3. Write 0.226 as 23%.

Thus, the market declined by 23%.

PROBLEM 2

One of the DJIA's biggest one-day slide occurred on September 17, 2001. On that day, the DJIA went down from 9606 to 8921.

To the nearest whole number, what was the percent of decrease?

Note: The decline that day was larger than the 508 points of October 19, 1987. Percentage-wise, however, the October 1987 decline was much larger.

Answers to PROBLEMS

1. 43% 2. 7%

B > Applications Involving Percent Increase or Decrease

Do you spend a lot on entertainment? In 2002, baby-boom households spent an average of \$2100 annually on entertainment. (This includes fees and admissions to parks, movies, plays, etc., and the cost of TVs, stereos, and other electronic equipment.) Are these costs going to increase? Read on.

EXAMPLE 3 Calculating percent increase

It is estimated that the amount spent on entertainment will *increase* by $33\frac{1}{3}\%$ in the next decade. If we are spending \$2100 annually now, how much will we be spending in a decade?

SOLUTION 3 This time, we have to find the *amount* of increase. Since we spend \$2100 now, in a decade we will be spending

$$\begin{aligned} 2100 + 33\frac{1}{3}\% \text{ of } 2100 \\ &= 2100 + \frac{1}{3} \times 2100 \\ &= 2100 + \frac{2100}{3} \\ &= 2100 + 700 \\ &= 2800 \end{aligned}$$

We will be spending \$2800 in a decade.

EXAMPLE 4 Calculating percent increase

Does it really pay to get a college education? Look at the graph! The brown (bottom) bars represent the annual earnings for all workers. If you were not a high school graduate, your annual earnings would be \$18,900. If you have a bachelor's degree, your annual earnings would be \$45,400. What is the percent increase in annual salary of having a bachelor's degree as compared to not being a high school graduate?

SOLUTION 4 To find the percent increase, look at the earnings for a worker who is not a high school graduate (\$18,900) and the earnings for a worker with a bachelor's degree (\$45,400).

The difference is $\$45,400 - \$18,900 = \$26,500$.

The percent increase is

$$\frac{\text{Increase}}{\text{Not high school}} = \frac{\$26,500}{\$18,900} \approx 140\%$$

$$\begin{array}{r} 1.402 \\ 18900 \overline{)26500.000} \\ \underline{18900} \\ 76000 \\ \underline{75600} \\ 40000 \\ \underline{37800} \\ 2200 \end{array}$$

Thus, the percent increase in pay for a bachelor's degree over not having a high school diploma is about 140%. That is, a worker with a bachelor's degree makes 140% more (\$26,500) than a worker who is not a high school graduate.

PROBLEM 3

The total amount spent on corporate travel and entertainment will increase by 21% in a 2-year period.

If \$95 billion was spent this year, how many billions of dollars will be spent in 2 years? (Answer to the nearest billion.)

PROBLEM 4

Find the percent increase (to the nearest percent) in annual salary between a worker who is not a high school graduate and a worker with a master's degree.

Average Annual Earnings by Educational Attainment

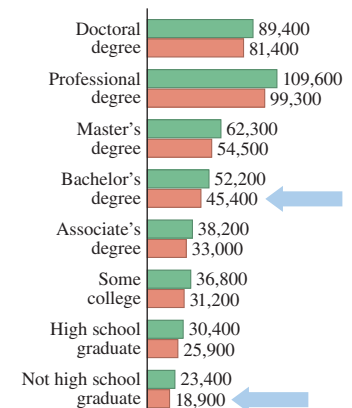

Legend:
■ Full-time, year round workers
■ All workers

Answers to PROBLEMS

3. \$115 billion 4. 188%

Now, suppose you want to buy a new car but you do not want to pay full price; instead, your goal is to pay the wholesale price of the car. How can you do it? First, you can go to one of the popular websites and find the base (invoice) price and the MSRP (manufacturer's suggested retail price) of the car you want. The information in the table is for a Honda Accord Coupe. To the nearest \$100, the invoice price is \$20,300 and the MSRP is \$22,600. What is the percent increase between these two prices? We will find out in Example 5.

Source: Data from Carprices.com.



	Honda	Accord
EX 2dr	Coupe	(2.4L 4cyl 5M)
MSRP	Invoice	
\$22,550	\$20,299	

EXAMPLE 5 Calculating percent increase

Find the percent increase between the invoice price of \$20,300 and the MSRP of \$22,600.

SOLUTION 5

This time the difference is: $\$22,600 - \$20,300 = \$2300$

\uparrow Wholesale \uparrow MSRP

The percent increase over the base is: $\frac{\$2300}{\$20,300} \approx 11\%$ (check this)

Thus, the dealer is making about **11%** (the percent increase) over the base price.

PROBLEM 5

Find the percent increase between the \$25,200 invoice price of a car and its MSRP of \$27,700. (Round the answer to the nearest percent.)

If you buy the car in Example 5, how much can you expect to get for it at the end of the year? It is estimated that a new car loses anywhere from 15% to 20% of its value the first year. This decline in price is called **depreciation**. Thus, if you bought the car in Example 5 for the invoice price of \$20,300, at the end of one year the car would depreciate between 15% of \$20,300 (\$3045) and 20% of \$20,300 (\$4060). Because of the depreciation, you should expect to get between \$17,255 (\$20,300 - \$3045) and \$16,240 (\$20,300 - \$4060) for the car 1 year later.

Let us look at an example with real data next.

EXAMPLE 6 Calculating percent decrease: Depreciation

The base price of a brand-new Ford Taurus is about \$19,000, according to Kelley Blue Book. The wholesale price of a Ford Taurus with just 100 miles on it is \$15,400, a drop of \$3600 from its original price. What is the percent of depreciation for the car?

SOLUTION 6

The difference is: $\$19,000 - \$15,400 = \$3600$

\uparrow New \uparrow Used

The percent decrease over the base is: $\frac{\$3600}{\$19,000} \approx 19\%$.

Thus, the depreciation after just putting 100 miles on the car is a whopping **19%**.

Source: Bankrate.com.

PROBLEM 6

The price of a car decreases from \$20,000 to \$15,000 after just 500 miles of use. What is the percent depreciation for the car?

Answers to PROBLEMS

5. 10% 6. 25%

Remember the Kyoto Protocol? (Example 4, Section 5.3.) It is based on percent increases and decreases. The United States, China, and the European Union are the countries that emit the most greenhouse gases (GHG). Let's see how they are doing as compared with the base year **1990**.

GREEN MATH

EXAMPLE 7 GHG emissions

According to Wolfram Data, the U.S. GHG emissions in 1990 were 6200 MMT. In 2007 they have increased to 7200 MMT. What is the percent increase? Is the increase within the 7% target?

SOLUTION 7

The difference is $7200 - 6200 = 1000$.

The percent increase over the base is $\frac{1000}{6200} = 16\%$

No, they increased by 16%, which is over the 7% target.

PROBLEM 7

The GHG emissions for China in 1990 were 2200 MMT but by 2010 they are estimated to increase to 6700 MMT. To the nearest whole number, what is the percent increase?

Note: China did sign the protocol but was classified as a “developing country” so is not yet required to begin reducing emissions.

> Exercises 5.5



> Practice Problems > Self-Tests
> Media-rich eBooks > e-Professors > Videos

< A > **Percent of Increase or Decrease** In Problems 1–13, give the answer to the nearest percent.

- A computer programmer received a \$4000 raise. If her previous salary was \$20,000, what was the percent of increase in salary?
- Felix Perez received a \$1750 annual raise from the state. If his salary was \$25,000 before the raise, what percent raise did he receive?
- In one 2-year period, the number of households reached by ESPN went from 60 to 70 million. Find the percent of increase in households reached.
- In one 2-year period, the number of households reached by ESPN went from 50 to 60 million. What percent of increase in households reached is that?
- It is estimated that the number of airline passengers at Chicago's O'Hare Airport will decrease from 76 million to 69 million in 1 year. What is the predicted percent of decrease in passengers at O'Hare?
- The number of airline passengers at Atlanta Airport in the year 2008 was 90 million, up from 89 million in 2007. What is the percent of increase in passengers for Atlanta?
- During a 2-year period, construction workers' average hourly earnings rose from \$18.27 to \$19.02. What is the percent increase?
- During a 2-year period, government workers' salaries rose from \$20,687 to \$21,187. What is the percent increase?
- In the first 3 months of one year, the DJIA rose from 10,000 to 10,400. What was the percent of increase?
- The 1929 stock market crash sent prices from a weekly peak of 380.3 in August 28, 1929, to a weekly bottom of 41.6 on July 4, 1932. To the nearest percent, what was the decline in prices?
- According to a United Airlines executive vice president, a flight from New York La Guardia Airport to Chicago O'Hare Airport took 130 minutes 5 years ago. Today, with aircraft just as fast, and traveling the same distance, it takes 140 minutes. What is the percent of increase in the time it takes to travel from New York to Chicago?
- During the year, the number of mishandled baggage complaints per 1000 passengers at the 10 largest airlines declined from 4.5 in February to 3.85 in March. Find the percent of decrease in complaints.
- During the first 6 months of the year, the number of mishandled baggage complaints per 1000 passengers at United Airlines decreased from 5.07 to 3.66. Find the percent of decrease in complaints.

Answers to PROBLEMS

7. $\frac{4500}{2200} = 205\%$

< B > Applications Involving Percent Increase or Decrease Give all answers to the nearest percent.

- 14. Increase in Supercenters** Have you been to one of those all-purpose stores called a Supercenter? In an 8-year period the number of Supercenters grew from 150 to 1200. What was the percent of increase of Supercenters in the 8-year period?
Source: ACNielsen.
- 16. Population increase** The total U.S. population will increase from 288 million in 2005 to 404 million in 2050. What is the percent of increase?
- 18. Dating increases** The largest paid content category on the Internet is Personals/Dating. The revenue in that area rose from \$72 million to \$302 million.
- What is the percent increase?
 - If you have a website dealing with Personals/Dating and your revenue was \$10,000, what would you expect your revenue to be next year based on the answer to part **a**?
- 20. Increase in Turbo Tax** During the month of April, taxpayers rush to Turbo Tax to learn more about their taxes. The number of visitors to Turbo Tax grew from 5.7 million to 6.8 million in one year.
- What is the percent increase?
 - If you have an online tax site that has 200 visitors, what would you expect the number of visitors to be next year based on the answer to part **a**?
- 22. Online travel plans** Do you make your travel plans on the Web? The Travel Industry Association indicates that around 64 million Americans now research their travel options online, an increase from the 12 million who did so in 1997.
- What is the percent increase?
 - If you have an online travel booking site that did 7000 bookings in 1997, how many would you expect this year based on the answer to part **a**?
- 24. Online use from work** In a survey by the Pew Internet and American Life Project, it was determined that 55 million Americans now go online from work, up from 43 million who went online two years earlier.
- What was the percent increase for the 2-year-period?
 - If you expect the same increase as in part **a** for your company and there are 500 employees going online from work this year, how many would you expect to go online from work 2 years from now?

- 26. Super Bowl prices** The prices for Super Bowl tickets are shown.

Source: Tickets.com.

XLI	2007	\$3659
XLII	2008	\$4332

- What was the increase from 2007 to 2008?
- What was the percent increase from 2007 to 2008?
- If the price increases by the same percent next year, what would you expect the price of a ticket to have been in 2009?

- 15. Growth of dollar stores** From 1993 to 2006, the number of dollar stores grew from 3650 to 16,000. What was the percent increase of dollar stores between 1993 and 2006?

Source: ACNielsen.

- 17. Increase in Hispanic population** The Hispanic population in the United States will increase from 38 million in 2005 to 98 million in 2050. What is the percent increase?

- 19. Increase in online content** In a certain year, the number of U.S. consumers paying for online content rose from 10 million to 13 million.

a. What is the percent increase?

b. If you have a website with 300 paying customers, how many customers would you expect next year based on the answer to part **a**?

- 21. Hospital website uses** According to a Manhattan Research study, 10.3 million online consumers have used a hospital website in the past 3 months, up from 3 million last year.

a. What is the percent increase?

b. If you are the webmaster of a hospital website that had 100,000 visitors in the past 3 months, how many visitors would you expect next year based on the answer to part **a**?

- 23. Shopping mall visits** According to the research firm comScore Media Metrix, college students' visits to online shopping sites have grown dramatically since September. During the week ending November 10, 4.8 million online college students visited shopping malls, compared to 3.7 million for the week ending September 1.

a. What was the percent increase in visitors?

b. If you have an online shopping site with 6000 visitors for the week ending September 1, how many visitors would you expect during the week ending November 10 based on the answer to part **a**?

- 25. CD rates** An ad at Bankrate.com states that you can invest \$10,000 in a CD at a 1.5% annual rate.

a. How much will your \$10,000 investment be worth at the end of one year?

b. If your investment at the end of one year is reduced by a 28% tax, how much will your \$10,000 investment be worth after taxes after one year?

- 27. Scalper rates** Scalpers usually sell tickets at a much higher price than the official \$400 rate. The table shows ticket prices for a recent Super Bowl on different days. (Game day is Sunday.)

Friday	\$1750
Saturday	\$1700
Game day	\$1500

a. What is the percent increase between

Friday's price and the official \$400 rate?

b. What is the percent decrease in price between Friday and Saturday?

c. What is the percent decrease in price between Saturday and game day (Sunday)?

- 28. Consolidation loans** According to the Financial Aid.com calculator, if you have \$20,000 in student loans with a \$217 monthly payment, you can decrease your monthly payment to \$123 with a consolidation loan at 3%.
- What is the percent of decrease in the payment?
 - The information about the consolidation states that the rate is 3%. Is this necessarily a better deal? Explain.
- 30. Cooling bills** During hot weather, if you raise the thermostat from 72° to 76° , your cooling bill will decrease by 40%. If your cooling bill was \$140 and you did raise the thermostat from 72° to 76° , what would you expect the cooling bill to be?

- 29. Consolidation loans** For this problem, look at the following information:

	Amount	Rate	Pmt	Time	Interest
Original	\$20,000	5.5%	\$217	10 yr	\$6040
Consolidated	\$20,000	3%	\$123	17.3 yr	\$5534.80

- What is the percent decrease in the interest paid between the original and the consolidated loan?
- What is the percent increase in the number of years between the original and the consolidated loan?
- With this information, reexamine Problem 28(b).

Applications: Green Math

The table shows the greenhouse gas (GHG) emissions in million metric tons (MMT) for **1990** and **2005**. Find, to the nearest percent:

- The percent of increase or decrease
- If the results exceeded the target rates, note that a target rate of 94 means that you can emit 94% of your 1990 figure; that is, you must have a 6% ($100 - 94 = 6$) **decrease**.

	Country	1990 Emissions	2005 Emissions	Target Rate
31.	Australia	280	294	108%
32.	Canada	460	580	94%
33.	Japan	1100	1300	94%
34.	Russia	2500	1700	100%
35.	Germany	1032	873	92%

Using Your Knowledge

College Tuition Fees Problems 36–40 refer to the graph in the *Getting Started* at the beginning of this section. Give the answers to the nearest percent.

- The cost of tuition and fees for private schools in 1978–1979 was about \$9900. In 2008–2009, it is about \$25,000. What is the percent increase?
- What is the percent difference between college costs at a public four-year college (\$6600) and a private college (\$25,000) in 2008–2009?
- Did the cost of private colleges more than double in the period 1978–1979 to 2008–2009? (See Problems 36 and 38.) Find the difference in cost between 1978–1979 and 2008–2009.
- What was the percent difference between college costs at a public four-year college (\$2300) and a private college (\$9900) in 1978–1979?
- Did the cost of public two-year colleges more than double in the period 1978–1979 to 2008–2009? Find the difference in cost between 1978–1979 and 2008–2009.

>>> Write On

41. Suppose you have a \$10,000 loan at 5% for 10 years with a \$106 monthly payment. You are offered a 3% loan with a \$100 monthly payment for 10 years. Is this a better loan? Explain. (*Hint:* The interest on the 5% loan is \$2720; the interest on the 3% loan is \$2000.)
42. The 3% loan with a \$100 monthly payment in Problem 41 can be paid in 115 monthly payments. Is this loan better than the original loan at 5% for 10 years? Explain.
43. Write in your own words the factors you would consider when comparing two loans.

>>> Concept Checker

Fill in the blank(s) with the correct word(s), phrase, or mathematical statement.

44. The **first step** in finding a percent of increase or decrease is to **find the amount** of _____ or _____. **increase** **original**
decrease **money**
45. The **second step** to find a percent of increase or decrease is to **divide** the amount of increase or decrease by the _____ amount.

>>> Mastery Test

Give the answer to the nearest percent.

46. The base price of a car is \$23,500. The dealer is selling it for \$25,000. What is the percent increase over the base price?
47. The base price for a car is \$25,000. The wholesale price for the same car after just using it for 100 miles is \$22,000. What is the percent of depreciation for the car?
48. The wholesale price of a car is \$20,000. The MSRP is \$22,000. What is the percent increase between the wholesale price and the MSRP?
49. The average annual earnings for a high school graduate are about \$26,000. For a person with an associate's degree, they are \$33,000. What is the percent increase in annual salary between a high school graduate and a person with an associate's degree?
50. A student estimated that the amount to be spent on entertainment had to be increased by 20% each month in order to satisfy current needs. If the student is spending \$200 a month on entertainment now, how much will the student be spending on entertainment next month?
51. On a certain month, the DJIA went down from 9000 to 8000. To the nearest percent, what was the percent of decrease?
52. From 1999 to 2000, the total amount for Pell Grants awarded to students went from \$43.5 billion to \$46.9 billion. Find the percent of increase to the nearest percent.

>>> Skill Checker

Give the answer to the nearest percent.

53. Find the interest on \$3550 at 18% for 1 month.
54. Find the interest on \$150,000 at 7.5% for 1 month.
55. Find 1.5% of \$260.
56. Find the compound amount A at 4% if \$1000 is compounded monthly for 2 months.
57. Find the compound amount A at 8% if \$1000 is compounded monthly for 2 months.

5.6

Consumer Credit

▶ Objectives

You should be able to solve application problems involving:

A > Credit cards.

B > Student loans.

C > Mortgages.

▶ To Succeed, Review How To . . .

1. Solve percent problems. (pp. 316–320, 328–330)
2. Perform basic operations on fractions and decimals. (pp. 135–138, 157–163, 210–215, 221–226)

▶ Getting Started

Which Card Is Better for You?

It depends on many factors such as the interest rate (the interest you pay the card company), the annual fee (how much you pay the card company for using the card), and the grace period (the interest-free time a lender allows between the transaction date and the billing date, usually 30 days). To learn the basics, look at the websites!

**A** > Credit Cards

How can you save money on your credit card? Look at the three terms we introduced in Getting Started and use them to your advantage. Here are three suggestions for savings:

1. Get the *lowest* possible interest rate (even 0% is sometimes available).
2. Get a card with *no* annual fee.
3. Pay off your entire balance within the *grace period* every month.

Let us see how all this works in practice.

EXAMPLE 1 Credit card comparisons

Suppose you have a card with a \$25 annual fee and an 18% annual percentage rate (APR). If the average monthly balance on your card is \$500 and you can get a different card with a 14% APR and no annual fee, how much will your savings be if you change to the second card?

SOLUTION 1 You will be saving

4% (18% – 14%) of \$500, or \$20, in interest and the \$25 annual fee.

The total savings amount to $\$20 + \$25 = \$45$.

PROBLEM 1

Suppose you have a card with a \$50 annual fee and a 10% APR. If your average monthly balance is \$1000 and you can get a card with a 14% APR and no annual fee, how much will your total savings be?

Answers to PROBLEMS

1. \$10

EXAMPLE 2 Credit card comparisons

If the average monthly balance on your card is \$500, your annual card fee is \$20, and your APR is 14%, does it make sense to change to another card with no annual fee and a 19% APR?

SOLUTION 2

With the first card you pay: 14% of \$500 or \$70, plus the \$20 fee, \$90 in all.
If you change to the second card, you pay 19% of \$500, or \$95.
It is better to stay with the **first** card.

PROBLEM 2

If the average monthly balance on your card is \$1000, your annual fee is \$50, and your APR is 12%, does it make sense to change to another card with no annual fee and an 18% APR?

EXAMPLE 3 Balance transfers

Desiree charged her vacation expenses of \$3550 to her credit card, which had an APR of 18%. She then decided not to make any additional purchases with this card until the balance was paid off.

- If the minimum payment on this card is 2% of the balance, find the minimum payment.
- Find the amount of interest and the amount applied to reduce the principal when the 2% minimum payment is made.
- Desiree received a special offer card with a 10% APR and no annual fee. How much of the 2% minimum payment would be interest and how much would be applied to reduce the principal with the new card?
- Compare the amounts by which the principal is reduced with the 18% and the 10% cards.

SOLUTION 3

- The minimum payment is 2% of \$3550 = $0.02 \times 3550 =$ **\$71**.
- The amount of interest for \$3550 at 18% for one month* is

$$0.18 \times 3550 \times \frac{1}{12} = \mathbf{\$53.25}$$

Since she made a \$71 payment, the amount going to reduce the principal is $\$71 - \$53.25 =$ **\$17.75**.

- With the 10% card, the interest for the month is

$$0.10 \times 3550 \times \frac{1}{12} = \mathbf{\$29.58}$$

The amount going to reduce the principal is $\$71 - \$29.58 =$ **\$41.42**.

- With the 18% card, the principal is reduced by **\$17.75** (she owes $\$3550 - \$17.75 =$ \$3532.25). With the 10% card, the principal is reduced by **\$41.42** (she owes $\$3550 - \$41.42,$ or \$3508.58).

*Technically, the interest on credit cards is calculated daily using the DPR (Daily Periodic Rate), which would be $\frac{0.18}{365}$ here, but the difference for the total interest for the month is very small.

PROBLEM 3

Repeat Example 3 if the balance was \$3000 and the original APR was 15%.

Now, suppose you receive this notice in the mail:

Limited-time 0% APR[†]
Your credit line has been increased to \$26,200!

with this fine print added at the end:

[†]Effective on or after the first day following your statement Closing Date in October, the Daily Periodic Rate (“DPR”) for new Cash Advances and for new Purchases posting to your account through your **April** statement Closing Date is 0% (corresponding **ANNUAL PERCENTAGE RATE** (“APR”) of 0%). Thereafter, the DPR for these promotional Cash Advance balances will be 0.035589% (corresponding **APR** of 12.99%), and the DPR for these promotional Purchase balances will be 0.035589% (corresponding **APR** of 12.99%).

Answers to PROBLEMS

- No
- a. \$60
b. \$37.50; \$22.50
c. \$25; \$35
d. \$22.50 with the 15% card,
\$35 with the 10% card

Remember, you have rights too!
Credit Cardholders' Bill of Rights of 2009

1. Stop raising rates in the first year after an account is opened and require that promotional rates last at least 6 months.
2. Stop issuers from charging fees for spending beyond credit limits, unless approved by the cardholder.
3. Post credit card agreements on the Internet and let customers pay their bills online or by phone without adding a fee.
4. Give a 45-day notice and explanation before increasing interest rates.

To read the entire Bill go to <http://tinyurl.com/ygbvsto>.

Important Reminder: The transaction fee for credit card access checks, including the enclosed checks, is 3% of each transaction (Min. \$5, Max. \$50). See your Credit Card Agreement for any other applicable transaction fees.

You have two credit cards with \$1000 and \$500 balances, respectively, each charging 9% APR, and you want to be debt free in 2 years! Should you take this deal to fulfill your debt-free goal? Before you do, read the fine print. The limited time at 0% is 6 months (from end of October to April). After that, your interest rate on the new card will be 12.99% (which we round to 13%). Let us compare the total amounts you would pay. Warning: You need a calculator!

PROBLEM SOLVING

1. Read the problem. You have two credit cards now, and you want to compare their total costs for a 2-year period to the cost of the new card at 0% interest for 6 months and 13% thereafter for the remaining 18 months (24 months total).

2. Select the unknown. We have two unknowns: (1) the amount to pay on the two old (9%) credit cards and (2) the amount to pay on the new 13% credit card. Both actions should take 2 years.

3. Translate the problem into an equation or inequality. We will use the compound amount formula. To figure the amount we have to pay for the two 9% credit cards and the new 13% card and compare the results, we use the formula for the compound amount $A = P(1 + i)^n$.

4. Use the rules we have studied and a calculator to solve the problem. For the two old cards, $P = \$1500$ (\$1000 + \$500), $n = 24$, $i = \frac{9\%}{12}$. Thus,

$$A = 1500\left(1 + \frac{0.09}{12}\right)^{24} = \$1794.62$$

For the new card, you do not pay interest for 6 months, and then you pay 13% for 18 months. $A = 1500\left(1 + \frac{0.13}{12}\right)^{18} = \1821.06

Thus, the new card with the 0% introductory rate is more expensive! (\$1821.06 against \$1794.62.) But there is more. To pay off the two 9% cards you have to write two checks, one for \$1000 and one for \$500. The Important Reminder tells you that the fee is 3% of each transaction, that is, \$30 and \$15, an additional \$45 cost. Definitely, stay with the old cards unless you are able to pay off the new card in 6 months at 0% interest.

5. Verify the answer. The verification is left to you.

Now that you know how to recognize the best credit card deals, let us concentrate on how to handle the card you have. As we mentioned, there are two things that can save you money: the interest rate (APR) you pay and the size of your monthly payment. They are both initially controlled by the credit card company, not you. Here are some typical rates and monthly payments:

Unpaid Balance	Monthly Rate
0–\$500	$\frac{18\%}{12} = 1.5\%$ monthly
Over \$500	$\frac{12\%}{12} = 1\%$ monthly
New Balance	Minimum Payment
Less than \$200	\$10
More than \$200	5% of the new balance

Let us see how this works.

EXAMPLE 4 Finding balances, finance charges, and payments

Khan received a statement from his credit card company. His previous balance was \$280. He made a \$20 payment and charged an additional \$60. If he pays 1.5% of the unpaid balance as a finance charge, find

- the unpaid balance.
- the finance charge.
- the new balance.
- the minimum payment (see table).

SOLUTION 4

- The unpaid balance is $\$280 - \$20 = \$260$.
- The finance charge is 1.5% of $\$260 = 0.015 \times 260 = \3.90 .
- The new balance is

Unpaid balance	\$260.00
Finance charge	\$3.90
Purchases	\$60.00
New balance	\$323.90
- Since the new balance is over \$200, the card company determines that the minimum payment should be

$$5\% \text{ of } \$323.90 = 0.05 \times 323.90 = \$16.1950 \text{ or } \$16.20$$

PROBLEM 4

Cecilia had a \$350 previous balance on her credit card. She made a \$50 payment and charged an additional \$200. If she pays 1.5% of the unpaid balance as a finance charge, find

- the unpaid balance.
- the finance charge.
- the new balance.
- the minimum payment.

We have already mentioned your Credit Cardholder's Bill of Rights, but the Federal Reserve has additional credit card protections for you. The key changes you should expect from your credit card company are listed at <http://tinyurl.com/y8ewcvk>. It will pay you to go there right now and read these changes. Among them are

- No interest rate increases on preexisting balances.
 - They must give you a 45-day advance notice before raising your interest rates.
 - No fees to make your credit card payment online, by mail, or over the phone.
- But here are two of the provisions that may affect you the most:
- No credit cards for minors under 18 unless they have been emancipated or are authorized users on a parent or guardian's account.
 - No credit cards for college students who do not have verifiable income or already have an account with the credit issuer.

You can learn even more by accessing a new online publication. "What you Need to Know: New Credit Card Rules" at <http://tinyurl.com/yaq5hpy>. For example, a new provision of the law will force the companies to tell you how long it will take to pay off your balance when you make only minimum payments or the amount of money you need to pay each month in order to pay off your balance in 3 years. We will explore this further in Example 5.



GREEN MAH

EXAMPLE 5 Protecting your green: Paying off your balance

Suppose you owe \$3000 and your interest rate is 14.4%—your bill will clearly show your balance (\$3000), your minimum payment due (3% of 3000 or \$90), and the due date, but it will also show you how long it will take to pay off the balance

PROBLEM 5

How do you know that the information they are giving you is accurate? You can go to

Answers to PROBLEMS

4. a. \$300 **b.** \$4.50 **c.** \$504.50 **d.** \$25.23 **5. a.** By making minimum payments only, it will take you 10 years and 4 months to pay off your credit cards. Based on your current combined balance of \$3000.00 you will pay a total of \$1655.92 in interest. Note that the answer here is 10 years and 4 months (124 months) instead of 11 years (132 months) and the interest is about \$100 less. **b.** If you pay \$101.89 a month, it will take you 3 years to pay off your credit cards. Based on your current combined balance of \$3000.00, you will pay a total of \$668.18 in interest. Again, your interest is less (\$668.18) and your payment is less (\$101.89 per month instead of \$103 per month).

if you make only the minimum payment and have no additional charges (11 years!) and the amount you need to pay each month to pay off the card in 3 years (\$103).

If you make no additional charges using this card and each month you pay . . .	You will pay off the balance shown on this statement in about . . .	And you will end up paying an estimated total of . . .
Only the minimum payment	11 years	\$4745
\$103	3 years	\$3712 (Savings = \$1033)

- How much interest will you pay if you make only the minimum payment?
- How much interest will you pay if you pay off the card in 3 years?
- How much money do you save if you pay off the card in 3 years?

SOLUTION 5

- You owe \$3000 and ended up paying \$4745 (pink), so your interest is

$$\$4745 - \$3000 = \$1745$$
- You owe \$3000 and ended up paying \$3712 (green), so your interest is

$$\$3712 - \$3000 = \$712$$
- Instead of paying \$1745 in interest you paid \$712 saving

$$\$1745 - \$712 = \$1033$$

Now you know how to save your green!

Specific rates and terms for these and other loans can be found in *Funding Education Beyond High School: The Guide to Federal Student Aid* at <http://tinyurl.com/2l8d7>.

The current limits for first, second, third, and beyond dependent undergraduate students are \$3500, \$4500, \$5500 a year for a maximum of \$23,000 in subsidized loans.

B > Student Loans

The terminology and ideas of credit cards are very similar to those used when dealing with student loans. The federal loan program for students attending school at least half-time is called the Stafford loan program, and interest rates are variable (they are reset each July 1) but are much lower than on credit cards (as low as 3.4%, capped at 8.25%). There are two types of Stafford loans: subsidized (based on need, with the interest paid by the federal government while the student is in school) and unsubsidized. The term of payment can be as high as 10 years (120 months) with payments starting 6 months after graduation.

EXAMPLE 6 Full Stafford loan

Panfilo successfully graduated from college after getting the full amounts allowed for Stafford loans at the time he attended: \$2625 as a freshman, \$3500 as a sophomore, \$5500 as a junior, and \$5500 as a senior, a total of \$17,125 at 3% for 10 years. His first payment was \$165.36.

- How much interest and how much principal are in the first payment?
- If his interest rate had been the maximum 8.25%, how much more of the first payment would have gone to interest as compared with his 3% loan and the \$165.36 payment?
- How much more total interest would be paid on an 8.25%, 10-year loan with a \$204.10 monthly payment as compared to the 3% loan and the \$165.36 payment over the same 10-year period?

SOLUTION 6

- We use the formula $I = P \times R \times T$, where $P = \$17,125$, $R = 3\%$, and $T = \frac{1}{12}$ ($\frac{1}{12}$ of a year is 1 month).

<http://tinyurl.com/yvrza> and find out! But be warned that different calculators give different answers!

- Enter your balance of \$3000, the interest rate (14.4%) and your minimum payment (\$90).

Balance(\$)	Interest rate(%)	Min. monthly payment(\$)
\$3000	14.4	90

How long does it take to pay off your debt? Choose your plan (minimum payments).

- Minimum payments**
 When will I be debt free and how much will I ultimately pay?

Calculate ▶

Press

- How long would it take to pay off your debt? This time choose Debt free deadline in 3 years.

Debt-free deadline

I want to pay off my credit cards in:

years and months

Calculate ▶

Press

PROBLEM 6

Latasha graduated from college also, but her Stafford loans amounted to \$15,000 at 4% for 10 years. Her payment was \$151.87.

- How much interest and how much principal are in the first payment?
- If her interest rate had been the maximum 8.25%, how much of the first payment would have gone to interest as compared with her 4% loan and the \$151.87 payment?
- How much more total interest would be paid on an 8.25%, 10-year loan with a \$183.98 monthly payment as compared to the 4% loan and the \$151.87 payment over the same 10-year period?

(continued)

Answers to PROBLEMS

6. a. \$50 interest, \$101.87 principal b. \$53.13 c. \$3853.20

The interest for 1 month is

$$I = 17,125 \times 0.03 \times \frac{1}{12} = \$42.81$$

The difference between the payment of \$165.36 and the interest of \$42.81, that is, $\$165.36 - \$42.81 = \$122.55$, goes to reduce the principal.

- b. The interest at 8.25% for 1 month would be

$$I = 17,125 \times 0.0825 \times \frac{1}{12} = \$117.73$$

The difference in interest between the 3% loan and the 8.25% loan is $\$117.73 - \$42.81 = \$74.92$.

- c. The amount paid at the 3% rate is $\$165.36 \times 120 = \$19,843.20$. Since the loan is for \$17,125, the interest is $\$19,843.20 - \$17,125$ or \$2718.20.

The amount paid at the 8.25% rate is $\$204.10 \times 120 = \$24,492$. On a \$17,125 loan, the interest is $\$24,492 - \$17,125 = \$7367$. Thus, at the 8.25% rate, the interest is $\$7367 - \$2718.20 = \$4648.80$ more than with the 3% rate.

The amount owed after the first month is
 $\$17,125 - \$122.55 =$
 $\$17,002.45$.

The interest is the difference between the total paid (\$19,843.20) and the amount of the loan (\$17,125).

You can get amortization tables for different rates and times, as well as principal and payment information, at <http://tinyurl.com/c7b94m>.

Note that your payment on the \$150,000 loan will be \$805.23 or \$899.23 instead of \$1048.82 at 5% and 6%, respectively. If your current payment is too high, you may try to refinance your mortgage.

C > Mortgages (Home Loans)

A **mortgage** is a long-term loan (usually to buy a house) that you can get from a bank, savings union, mortgage broker, or online lender. Because mortgages involve such large amounts, they are paid over longer periods, usually 15 to 30 years. The breakdown of each payment (the amount that goes toward principal, interest, etc.) changes over time, and is detailed in an **amortization table** like the one shown for a 30-year, \$150,000 mortgage at a fixed 7.5% rate. (Rates vary.)

Amortization Table for a \$150,000, 30-Year Mortgage at 7.5%

Here's how principal and interest change over the life of a loan

Payment Number	Principal Balance	Payment Amount	Interest Paid	Principal Applied	New Balance
1	\$150,000	\$1048.82	\$937.50	\$111.32	\$149,888.68
60	\$142,086.93	\$1048.82	\$888.04	\$160.78	\$141,926.15
120	\$130,426.14	\$1048.82	\$815.16	\$233.66	\$130,192.48
240	\$88,851.22	\$1048.82	\$555.32	\$493.50	\$88,357.72
359	\$2078.14	\$1048.82	\$12.99	\$1035.83	\$1042.31
(next to last)					

Source: Data from Bankrate.com.

EXAMPLE 7 Interest on a 30-year mortgage

Suppose you have a \$150,000, 30-year mortgage at 7.5% with a monthly payment of \$1048.82.

- What would the interest be in the first month?
- How much of the \$1048.82 payment would go toward paying the \$150,000 principal?
- Look at the amortization table and determine what the principal balance and the new balance are on the next-to-last payment.

PROBLEM 7

Suppose you have a \$100,000, 30-year mortgage at 6% with a monthly payment of \$600.

- What would the interest be in the first month?
- How much of the \$600 payment would go toward paying the \$100,000 principal?

Answers to PROBLEMS

7. a. \$500 b. \$100

SOLUTION 7

- a. The interest is $I = P \times R \times T$, where $P = \$150,000$, $R = 7.5\%$, and T is $\frac{1}{12}$ ($\frac{1}{12}$ of a year is 1 month).
Thus, $I = 150,000 \times 0.075 \times \frac{1}{12} = \937.50 . (Exciting—it is just like in the amortization table!)
- b. The payment is \$1048.82 and the interest is \$937.50, so the amount that would go toward paying the principal is $\$1048.82 - \$937.50 = \$111.32$. (Wow, just like the table again!)
- c. The principal balance for payment 359 is \$2078.14. The new balance is \$1042.31. When you pay that, you are paid up!

> Exercises 5.6



- > Practice Problems > Self-Tests
- > Media-rich eBooks > e-Professors > Videos

< A > Credit Cards In Problems 1–7, follow the procedure in Example 4 to complete the table.

	Previous Balance	Payment	Unpaid Balance	Finance Charge (1.5%)	Purchases	New Balance
1.	\$100	\$10	_____	_____	\$50	_____
2.	\$300	\$190	_____	_____	\$25	_____
3.	\$134.39	\$25	_____	_____	\$73.98	_____
4.	\$145.96	\$55	_____	_____	\$44.97	_____
5.	\$378.93	\$75	_____	_____	\$248.99	_____
6.	\$420.50	\$100	_____	_____	\$300	_____
7.	\$500	\$300	_____	_____	\$250	_____

In Problems 8–16, use the table below to determine:

- a. the finance charge for the month.
- b. the new balance.
- c. the minimum monthly payment.

Unpaid Balance	Monthly Rate
0–\$500	$\frac{18\%}{12} = 1.5\%$ monthly
Over \$500	$\frac{12\%}{12} = 1\%$ monthly
New Balance	Minimum Payment
Less than \$200	\$10
More than \$200	5% of the new balance

	Previous Balance	New Purchases
8.	\$50.40	\$173
9.	\$85	\$150
10.	\$154	\$75
11.	\$344	\$60
12.	\$666.80	\$53.49
13.	\$80.45	\$98.73
14.	\$34.97	\$50
15.	\$55.90	\$35.99
16.	\$98.56	\$45.01

< B > Student Loans In Problems 17–18, solve the Stafford loan problems.

- 17.** After graduation, the balance on Marcus's Stafford loan was \$20,000, to be paid at 3% for 10 years (120 payments). His first payment was \$193.12.
- How much interest and how much principal are in the first payment?
 - If his interest rate had been the maximum 8.25%, how much more of the first payment would have gone to interest as compared with his 3% loan and the \$193.12 payment?
 - How much more total interest would be paid on an 8.25%, 10-year loan with a \$245.31 monthly payment as compared to the 3% loan and the \$193.12 payment over the same 10-year period?
- 18.** Frances had a \$25,000 Stafford loan at 2.85% to be paid after graduation with 120 payments (10 years) of \$239.67.
- How much interest and how much principal are in the first payment?
 - If her interest rate had been the maximum 8.25%, how much more of the first payment would have gone to interest as compared with her 2.85% loan and the \$239.67 payment?
 - How much more total interest would be paid on an 8.25%, 10-year loan with a \$306.63 monthly payment as compared to the 2.85% loan and the \$239.67 payment over the same 10-year period?

The chart shows the estimated standard repayment chart for several loan amounts at different interest rates. In Problems 19–22,

- Find the interest for the first month for the 6% loans of \$10,000, \$18,500, \$20,000, and \$23,000.
- Find the amount of the first payment that will go to pay the principal for each of the four loans.
- Find the total amount of interest that will be paid for each of the four loans.

Estimated Standard Repayment Chart

Interest Rate: ¹	5.00%	6.00%	7.00%	8.25%	
Loan Amount	Number of Payments²	Approximate Monthly Payments³			
19. \$10,000	120	\$106	\$111	\$116	\$123
20. \$18,500	120	\$196	\$205	\$215	\$227
21. \$20,000	120	\$212	\$222	\$232	\$245
22. \$23,000	120	\$244	\$255	\$267	\$282

1. Rate is as shown. 2. (120) but terms may vary. 3. At least \$50.

Source: Educaid.com.

< C > Mortgages (Home Loans) In Problems 23–24, answer the questions about mortgages.

- 23.** Athanassio and Gregoria Pappas want a 30-year loan at 7% to buy a small \$50,000 house in Tarpon Springs.
- If they can get a loan for 95% of the value of the house, what will be the amount of the loan?
 - The difference between the loan amount and the \$50,000 is the down payment. How much would that be?
 - If the monthly payment is \$316, how much of the first payment is principal and how much is interest?
- 24.** Tim and Frances Johnston wish to obtain a 30-year, \$40,000 loan at 9% to buy a house in Georgia.
- If they can get a loan for 95% of the value of the house, what will be the amount of the loan?
 - The difference between the loan amount and the \$40,000 is the down payment. How much would that be?
 - If the monthly payment is \$305, how much of the first payment is principal and how much is interest?

The charts show loan amortization schedules for the principal shown (30-year loans). In Problems 25–28,

- Find the interest paid, principal applied, and new balance on line 1.
- Find the interest paid, principal applied, and new balance on line 2.

Loan Amortization

Number	Principal Balance	Payment Amount	Interest Paid: 6%	Principal Applied	New Balance
25. 1	\$100,000.00	\$599.55	_____	_____	_____
2	\$99,900.45	\$599.55	_____	_____	_____

Loan Amortization

26.

Number	Principal Balance	Payment Amount	Interest Paid: 5%	Principal Applied	New Balance
1	\$100,000.00	\$536.82	_____	_____	_____
2	\$99,879.85	\$536.82	_____	_____	_____

Loan Amortization

27.

Number	Principal Balance	Payment Amount	Interest Paid: 7%	Principal Applied	New Balance
1	\$150,000.00	\$997.95	_____	_____	_____
2	\$149,877.05	\$997.95	_____	_____	_____

Loan Amortization

28.

Number	Principal Balance	Payment Amount	Interest Paid: 8%	Principal Applied	New Balance
1	\$200,000.00	\$1467.53	_____	_____	_____
2	\$199,865.80	\$1467.53	_____	_____	_____

Some people (not you, of course) may think that if you get a 30-year mortgage for \$125,000 the interest you pay is found using the simple interest formula $I = P \times R \times T$, where I is the interest, P the principal, R the rate, and T the time in years (see Example 5).

29. Find the simple interest when $P = \$125,000$, $R = 0.06$, and $T = 30$.

(Note: This answer is *not* correct, since a mortgage uses *compound* instead of *simple* interest.) To see how much interest you *really* have to pay, you must consult the graph.

30. To find the actual interest paid on a 30-year, \$125,000 loan say at 10%, look at the graph. The top of the bar labeled 10% shows the interest: \$269,907. However, that is not all you pay, you must pay the \$125,000 principal as well, for a total of \$394,907.

- a. Refer to the graph and find the interest paid on a 30-year, \$125,000 loan at 9%.
 b. Find the total amount (interest plus principal) on a 30-year, \$125,000 loan at 9%.

31. a. Refer to the graph and find the interest paid on a 30-year, \$125,000 loan at 6%.
 b. Find the total amount (interest plus principal) on a 30-year, \$125,000 loan at 6%.

Total Interest Paid on a 30-Year \$125,000 Loan at Various Rates

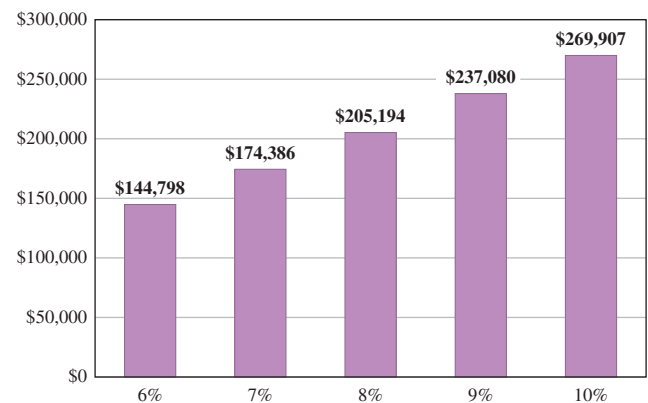

Source: <http://michaelbluejay.com/house/loan.html>.

32. a. Refer to the graph and find the interest paid on a 30-year, \$125,000 loan at 8%.
 b. Find the total amount (interest plus principal) on a 30-year, \$125,000 loan at 8%.

Collaborative Learning

Do you know what the ten hottest careers for college graduates are? The 10 fastest-growing occupations between 2002 and 2012 are shown in the table and are either technology related or medical/health related. If you are trying to decide on a career, exploring the available opportunities could help with your choice. To find a fast-growing career, divide into groups and do the following:

1. Separate these 10 careers into two categories—Technical or Medical. Fill in the last column (% *I*) with the percent increase for that career. The percent increase is found by dividing the difference of the two numbers by the original number.
2. Answer the following questions:
 - a. Of the two categories, which field seems to have higher percents of increase?
 - b. In the technology field, which career has the highest percent of increase? The lowest?
 - c. In the medical field, which career has the highest percent of increase? The lowest?
 - d. Besides the availability of jobs, what other information would you want to know about a career?

10 Fastest-Growing Occupations for College Grads

Occupation	2002	2012	% <i>I</i>
Network systems and data communications analysts	186	292	
Physician assistants	63	94	
Medical records and health information technicians	147	216	
Computer software engineers, applications	394	573	
Computer software engineers, systems software	281	409	
Physical therapist assistants	50	73	
Fitness trainers and aerobics instructors	183	264	
Database administrators	110	159	
Veterinary technologists and technicians	53	76	
Dental hygienists	148	212	

Source: United States Bureau of Labor Statistics.



Research Questions

The chart shows the total U.S. population and the African-American population according to the U.S. census (conducted every 10 years).

1. To the nearest percent, what was the African-American population in each of the years listed?
2. In what year was the percent of African-Americans highest?
3. What was the highest percent decrease in the African-American population? In what time period?
4. What was the highest percent increase in the African-American population? In what time period?

(continued)

Year	Total U.S. Population	African-American Population
1860	31,400,000	4,400,000
1880	50,100,000	6,500,000
1900	76,000,000	9,100,000
1920	105,700,000	10,500,000
1940	131,700,000	13,200,000
1960	179,300,000	17,900,000
1980	226,500,000	27,200,000
2000	281,400,000	36,400,000

Source: U.S. Census data. All numbers are rounded.

- 5.** Now, some real research! Make a table like this one and answer questions 1–4 about the Hispanic population.

Hint: You can find some of the information by doing a Web search on “census statistics.”

Summary Chapter 5

Section	Item	Meaning	Example
5.1	Percent	Per hundred	$9\% = \frac{9}{100}$
5.2	Base (total)	The standard used for comparison purposes	$B = \frac{P}{R}$; B the base, P the percentage, R the rate.
	Percentage	The part being compared with the base or total	$P = B \times R$
	Percent (rate)	The part indicating the ratio of the percentage to the base	$R = \frac{P}{B}$
5.3	Solving percent problems using proportions	To solve percent problems using proportions, set up the proportion $\frac{\text{Percent}}{100} = \frac{\text{Part}}{\text{Whole}}$	<ol style="list-style-type: none"> To find 40% of 50, set up the proportion $\frac{40}{100} = \frac{n}{50}$and solve the proportion. To find what percent of 50 is 10, set up the proportion $\frac{\text{Percent}}{100} = \frac{10}{50}$then solve it. To find a number so that 30% of it is 60, set up the proportion $\frac{30}{100} = \frac{60}{\text{Whole}}$then solve it.
5.4A	Total cost	List price + sales tax	The total cost of an item listed at \$200 when the tax rate is 5% is: $200 + 200 \times 0.05 = \$210.$

Section	Item	Meaning	Example
5.4B	Simple interest	The amount paid for using money $I = P \times R \times T$	The amount paid for borrowing \$100 at 6% simple interest for one year is $I = 100 \times \frac{6}{100} \times 1$ $= \$6$
5.4C	Compound interest	Total compound amount A for a rate i per period applied to a principal P for n periods is given by computing interest on the earned interest $A = P(1 + i)^n$	\$100 invested at 6% compounded semiannually for one year earns \$6.09 in interest. The compound amount A for a \$100, three-year deposit compounded at 4% semiannually is $A = 100\left(1 + \frac{4\%}{2}\right)^6$
5.4D	Commission	A share of the sales price earned by a salesperson	A 5% commission on a \$300 sale is $\$300 \times 0.05 = \15 .
5.4E	Discount	A reduction in the regular price of an item	A 2% discount on a \$500 item amounts to $\$500 \times 0.02 = \10 .
5.5A	Percent increase/decrease	The percent a given quantity increases or decreases	If an item increases in price from \$10 to \$12, the percent increase is $\frac{12 - 10}{10} = \frac{2}{10} = 20\%$.
5.5B	Depreciation	The loss in value of an item	A \$20,000 car is valued at \$18,000 after two years. The depreciation of the car is $\frac{20,000 - 18,000}{20,000} = \frac{2,000}{20,000} = 10\%$.
5.6A	APR	Annual Percentage Rate	The APR on credit cards varies from 6% to 18%.
5.6B	Stafford loan	A type of federal student loan	Rates vary and are adjusted every July but cannot exceed 8.25%.
5.6C	Mortgage	A long-term loan (usually to buy a house) that you can get from a bank, credit union, mortgage broker, or online lender	You may have a 30-year, 6% mortgage on your home (terms and interest rates vary).

Review Exercises Chapter 5

(If you need help with these exercises, look in the section indicated in brackets.)

- 1. <5.1A>** Write as a decimal.

a. 39% b. 1% c. 13% d. 101% e. 207%
- 2. <5.1A>** Write as a decimal.

a. 3.2% b. 11.2% c. 71.4% d. 17.51% e. 142.5%
- 3. <5.1A>** Write as a decimal.

a. $6\frac{1}{4}\%$ b. $71\frac{1}{2}\%$ c. $5\frac{3}{8}\%$ d. $17\frac{1}{4}\%$ e. $52\frac{1}{8}\%$
- 4. <5.1A>** Write as a repeating decimal.

a. $6\frac{1}{3}\%$ b. $8\frac{2}{3}\%$ c. $1\frac{1}{6}\%$ d. $18\frac{2}{9}\%$ e. $20\frac{1}{9}\%$

5. **<5.1B>** Write as a percent.
 a. 0.01 b. 0.07 c. 0.17
 d. 0.91 e. 0.83
7. **<5.1C>** Write as a reduced fraction.
 a. 17% b. 23% c. 51%
 d. 111% e. 201%
9. **<5.1C>** Write as a reduced fraction.
 a. $16\frac{2}{3}\%$ b. $33\frac{1}{3}\%$ c. $62\frac{1}{2}\%$
 d. $83\frac{1}{3}\%$ e. $87\frac{1}{2}\%$
11. **<5.2A>** Find the percentage.
 a. 60% of 30 is what number?
 b. 70% of 140 is what number?
 c. 40% of 80 is what number?
 d. 30% of 90 is what number?
 e. 35% of 105 is what number?
13. **<5.2B>** Find the percent.
 a. What percent of 20 is 5?
 b. What percent of 50 is 10?
 c. What percent of 60 is 20?
 d. What percent of 80 is 160?
 e. What percent of 5 is 1?
15. **<5.2B>** Find the percent.
 a. 20 is what percent of 40?
 b. 30 is what percent of 90?
 c. 60 is what percent of 80?
 d. 90 is what percent of 60?
 e. 30 is what percent of 80?
17. **<5.2C>** Find the base.
 a. 60 is 40% of a number. Find the number.
 b. 90 is 30% of a number. Find the number.
 c. 40 is 80% of a number. Find the number.
 d. 75 is 5% of a number. Find the number.
 e. 42 is 50% of a number. Find the number.
19. **<5.3A>** Set up a proportion and find the number.
 a. What is 30% of 40?
 b. What is 40% of 72?
 c. What is 50% of 94?
 d. What is 60% of 50?
 e. What is 70% of 70?
6. **<5.1B>** Write as a percent.
 a. 3.2 b. 1.1 c. 7.9
 d. 9.1 e. 4.32
8. **<5.1C>** Write as a reduced fraction.
 a. 10% b. 40% c. 15%
 d. 35% e. 42%
10. **<5.1D>** Write as a percent.
 a. $\frac{3}{8}$ b. $\frac{5}{8}$ c. $\frac{1}{16}$
 d. $\frac{3}{16}$ e. $\frac{5}{16}$
12. **<5.2A>** Find the percentage.
 a. $12\frac{1}{2}\%$ of 80
 b. $40\frac{1}{2}\%$ of 60
 c. $15\frac{1}{2}\%$ of 250
 d. $10\frac{2}{3}\%$ of 300
 e. $24\frac{3}{4}\%$ of 7000
14. **<5.2B>** Find the percent.
 a. Find what percent of 40 is 30.
 b. Find what percent of 50 is 20.
 c. Find what percent of 20 is 40.
 d. Find what percent of 30 is 20.
 e. Find what percent of 60 is 10.
16. **<5.2C>** Find the base.
 a. 30 is 50% of what number?
 b. 20 is 40% of what number?
 c. 15 is 75% of what number?
 d. 20 is 60% of what number?
 e. 60 is 90% of what number?
18. **<5.2C>** Find a number so that:
 a. 40% of the number is 10.
 b. 50% of the number is 5.
 c. 70% of the number is 140.
 d. 65% of the number is 195.
 e. 16% of the number is 40.
20. **<5.3B>** Set up a proportion and find the percent.
 a. 80 is what percent of 800?
 b. 22 is what percent of 110?
 c. 28 is what percent of 70?
 d. 90 is what percent of 180?
 e. 80 is what percent of 40?

21. <5.3C> Set up a proportion and find the number.

- 20 is 10% of what number?
- 30 is 12% of what number?
- 45 is 90% of what number?
- 50 is 25% of what number?
- 63 is 18% of what number?

22. <5.4A> In each problem find the total price for the given tax rate and price.

	Tax	
	Rate (%)	Price
a.	6	\$20
b.	4	50
c.	5	18
d.	6.5	80
e.	4.5	300

23. <5.4B> Find the simple interest.

	Amount	Annual Rate (%)	Time (Years)
a.	\$100	10	2
b.	250	12	3
c.	300	15	2
d.	600	9	2
e.	3000	8.5	3

24. <5.4B> Find the simple interest.

	Amount	Annual Rate (%)	Time (Months)
a.	\$600	10	2
b.	600	12	3
c.	250	8	6
d.	450	9	8
e.	300	13	10

25. <5.4C> If interest is compounded semiannually, find the compound amount and the interest when \$10,000 is invested at

- 4% for 2 years.
- 6% for 2 years.
- 8% for 2 years.
- 10% for 2 years.
- 12% for 2 years.

26. <5.4D> Find the commission.

	Sale	Commission Rate (%)
a.	\$100	8
b.	250	6
c.	17,500	7
d.	300	6.5
e.	700	5.5

27. <5.4E> Find the sale price for the given article.

	Regular Price	Discount Rate (%)
a.	\$35	40
b.	40	50
c.	60	$33\frac{1}{3}$
d.	90	10
e.	540	15

28. <5.5A> Find the percent of increase of sales (to the nearest percent) for a company whose sales increased from \$2 billion to

- \$3 billion.
- \$3.1 billion.
- \$3.2 billion.
- \$3.3 billion.
- \$3.4 billion.

29. <5.5A> To the nearest percent, what is the percent of decrease in the price of gold currently selling at \$400 an ounce if the new price is

- \$395 an ounce.
- \$390 an ounce.
- \$385 an ounce.
- \$380 an ounce.
- \$375 an ounce.

30. <5.5A> ABC Manufacturing's current sales are \$48 million annually. Find the projected sales for next year if sales are to increase by

- $16\frac{2}{3}\%$
- $33\frac{1}{3}\%$
- $37\frac{1}{2}\%$
- $66\frac{2}{3}\%$
- $83\frac{1}{3}\%$

31. **<5.6A>** If the finance charge is 1.5% of the unpaid balance, find the unpaid balance, the finance charge, and the new balance.

	Previous Balance	Payment	Additional Charges
a.	\$100	\$20	\$50
b.	\$150	\$30	\$60
c.	\$200	\$40	\$70
d.	\$300	\$100	\$100
e.	\$500	\$200	\$300

32. **<5.6B>** Based on the information in the following table, find

How much interest and how much principal are in the first payment on the 3% loan.

If the interest rate were the maximum 8.25%, how much more of the first payment would go to interest as compared with the 3% loan and the corresponding payment?

How much more total interest would be paid on an 8.25%, 10-year loan with the payment shown as compared to the 3% loan and the payment shown?

	Stafford Loan	Rate	Term	1st Pmt (at 3%)	1st Pmt (at 8.25%)
a.	\$5000	3%	10 yr	\$48.28	\$61.33
b.	\$10,000	3%	10 yr	\$96.56	\$122.65
c.	\$15,000	3%	10 yr	\$144.84	\$183.98
d.	\$20,000	3%	10 yr	\$193.12	\$245.31
e.	\$25,000	3%	10 yr	\$241.40	\$306.63

Practice Test Chapter 5

Visit www.mhhe.com/bello to view helpful videos that provide step-by-step solutions to several of the problems below.

(Answers on page 368)

1. a. Write 37% as a decimal.
b. Write 17.8% as a decimal.
3. a. Write 0.09 as a percent.
b. Write 5.1 as a percent.
5. Write $12\frac{1}{2}\%$ as a reduced fraction.
7. 70% of 50 is what number?
9. What is $33\frac{1}{3}\%$ of 96?
11. 40 is 50% of what number?
13. Set up a proportion and find what percent of 80 is 20.
15. If the sales tax rate in one city is 5%, find the total price paid for a pair of shoes that cost \$16.60.
17. Find the simple interest earned on \$1200 invested at 5.5% for 3 months.
19. What is the commission of a salesperson on a \$400 sale if her commission rate is 15%?
21. The sales of children's sneakers rose from \$2 billion to \$2.4 billion. Find the percent of increase to the nearest percent.
23. A company estimates that expenses will increase by $33\frac{1}{3}\%$ during the next year. If expenses are currently \$81 million, how much will the company be spending next year?
25. A student had a \$20,000 loan at 4% for 10 years. The first payment was \$202.49.
 - a. How much interest and how much principal are in the first payment?
 - b. If the interest rate were the maximum 8.25%, how much more of the first payment would have gone to interest as compared with the 4% loan and \$202.49 payment?
 - c. How much more total interest would be paid on an 8.25%, 10-year loan with a \$245.31 monthly payment as compared to the 4% loan and the \$202.49 payment over the same 10-year period?
2. a. Write $5\frac{1}{4}\%$ as a decimal.
b. Write $15\frac{2}{3}\%$ as a repeating decimal.
4. a. Write 11% as a reduced fraction.
b. Write 60% as a reduced fraction.
6. Write $\frac{7}{8}$ as a percent.
8. Find $10\frac{1}{2}\%$ of 80.
10. Find what percent of 50 is 30.
12. Set up a proportion and find 10% of 40.
14. Set up a proportion and find 40% of what number is 10.
16. Find the simple interest earned on \$500 invested at 6.5% for 2 years.
18. Find the compound amount and the interest when \$10,000 is invested at 6% compounded semiannually for two years.
20. Find the sale price of an article regularly selling for \$19.50 that is being advertised at 30% off.
22. In a certain week, the London stock market went down from 1740 to 1653. What was the percent of decrease to the nearest percent?
24. A student received a statement from a credit card company. The previous balance was \$480, a \$50 payment was made, and an additional \$100 was charged to the account. If the finance charge is 1.5% of the unpaid balance, find
 - a. the unpaid balance.
 - b. the finance charge.
 - c. the new balance.

› Answers to Practice Test Chapter 5

Answer	If You Missed		Review	
	Question	Section	Examples	Page
1. a. 0.37 b. 0.178	1	5.1	1	307
2. a. 0.0525 b. $0.15\overline{6}$	2	5.1	2	307
3. a. 9% b. 510%	3	5.1	3	308
4. a. $\frac{11}{100}$ b. $\frac{3}{5}$	4	5.1	4	308
5. $\frac{1}{8}$	5	5.1	5	309
6. $87\frac{1}{2}\%$	6	5.1	6, 7	309–310
7. 35	7	5.2	1	317
8. 8.4	8	5.2	2	318
9. 32	9	5.2	3	318
10. 60%	10	5.2	4	319
11. 80	11	5.2	5	320
12. $\frac{10}{100} = \frac{\text{Part}}{40}$; Part = 4	12	5.3	1	329
13. $\frac{\text{Percent}}{100} = \frac{20}{80}$; Percent = 25%	13	5.3	2	329
14. $\frac{40}{100} = \frac{10}{\text{Whole}}$; Whole = 25	14	5.3	3	330
15. \$17.43	15	5.4	1	334
16. \$65	16	5.4	2	335
17. \$16.50	17	5.4	2	335
18. \$11,255.09; \$1255.09	18	5.4	3, 4	335–336
19. \$60	19	5.4	5	337
20. \$13.65	20	5.4	6	337
21. 20%	21	5.5	1	344
22. 5%	22	5.5	2	344
23. \$108 million	23	5.5	3–6	345–346
24. a. \$430 b. \$6.45 c. \$536.45	24	5.6	1–4	351–352, 354
25. a. \$66.67 int.; \$135.82 principal b. \$70.83 c. \$5138.40	25	5.6	6–7	355–357

> Cumulative Review Chapters 1–5

1. Write six thousand, five hundred ten in standard form.
2. Simplify: $36 \div 6 \cdot 6 + 7 - 3$
3. Classify $\frac{7}{6}$ as proper or improper.
4. Write $\frac{31}{4}$ as a mixed number.
5. Write $6\frac{4}{9}$ as an improper fraction.
6. Multiply: $(\frac{5}{6})^2 \cdot \frac{1}{25}$
7. Divide: $\frac{10}{7} \div 8\frac{1}{3}$
8. Translate and solve: $\frac{3}{4}$ less than a number x is $\frac{1}{3}$. What is x ?
9. Find a number such that $\frac{10}{11}$ of it is $7\frac{1}{9}$.
10. Give the word name for 342.41.
11. Write 34.773 in expanded form.
12. Subtract: $641.42 - 14.5$
13. Multiply: $5.94 \cdot 1.5$
14. Divide: $\frac{189}{0.27}$
15. Round 749.851 to the nearest tenth.
16. Divide: $10 \div 0.13$ (Round answer to two decimal digits.)
17. Write $0.\overline{12}$ as a reduced fraction.
18. What decimal part of 12 is 3?
19. Arrange in order of decreasing magnitude and write using the $>$ sign:
4.293 4.29 $\overline{3}$ 4.29 $\overline{3}$
20. Insert =, <, or > to make a true statement:
0.25 _____ $\frac{13}{20}$
21. Solve for x : $x + 2.3 = 6.2$
22. Solve for y : $1.4 = 0.2y$
23. Solve for z : $5 = \frac{z}{4.2}$
24. The ratio of cars to people in New Zealand is 480 to 1000. Write this ratio as a fraction in reduced form.
25. Write the following proportion: 5 is to 9 as 40 is to x .
26. There is a law stating that “the ratio of width to length for the American flag should be 10 to 19.” Is a flag measuring 50 by 97 feet in the correct ratio?
27. Solve the proportion: $\frac{f}{4} = \frac{5}{80}$
28. Solve the proportion: $\frac{12}{f} = \frac{2}{3}$
29. A student traveled 300 miles on 16 gallons of gas. How many miles per gallon did the student get? (Round to the nearest whole number.)
30. A 24-ounce jar of peanut butter costs \$2.79. What is the unit price in cents per ounce? (Answer to the nearest cent.)
31. A pound of grass seed covers 3500 square feet of lawn. How many pounds are needed to cover a lawn measuring 200 by 70 feet (14,000 square feet)?
32. The protein RDA for males is 56 grams per day. Four ounces of a certain product provide 2 grams of protein. How many ounces of the product are needed to provide 56 grams of protein?
33. Write 12% as a decimal.
34. Write $7\frac{1}{4}\%$ as a decimal.
35. Write 0.03 as a percent.
36. 10% of 80 is what number?
37. What is $66\frac{2}{3}\%$ of 54?
38. What percent of 32 is 16?
39. 12 is 60% of what number?
40. The sales tax rate in a certain state is 5%. Find the total price paid for a pair of shoes that costs \$16.
41. Find the simple interest earned on \$400 invested at 8.5% for 2 years.

This page intentionally left blank

Section

Chapter

- 6.1 Tables and Pictographs
- 6.2 Bar and Line Graphs
- 6.3 Circle Graphs (Pie Charts)
- 6.4 Mean, Median, and Mode

6

six

► Statistics and Graphs

The Human Side of Mathematics

Statistical analysis was born in London, where in 1662 John Graunt published a remarkable book, *Natural and Political Observations upon the Bills of Mortality*. The causes of death (weird diseases such as jawfalln, King's-Evil, planet, and tissick) were reported in the Bills of Mortality, which were published regularly starting in 1629, and were presented as London's "dreadful visitations."

After this perhaps morbid beginning for statistical analysis, many mathematicians, among them such famous ones as Pierre-Simon Laplace (1749–1827) and Carl Friedrich Gauss (1777–1855), made important contributions to the basic ideas of statistics. Furthermore, the analysis of numerical data is fundamental in so many different fields that one could make a long list of scientists in such areas as biology, geology, genetics, and evolution who contributed greatly to this study. The well-known names of Charles Darwin (1809–1882) and Gregor Mendel (1822–1884) would surely be included in this list.

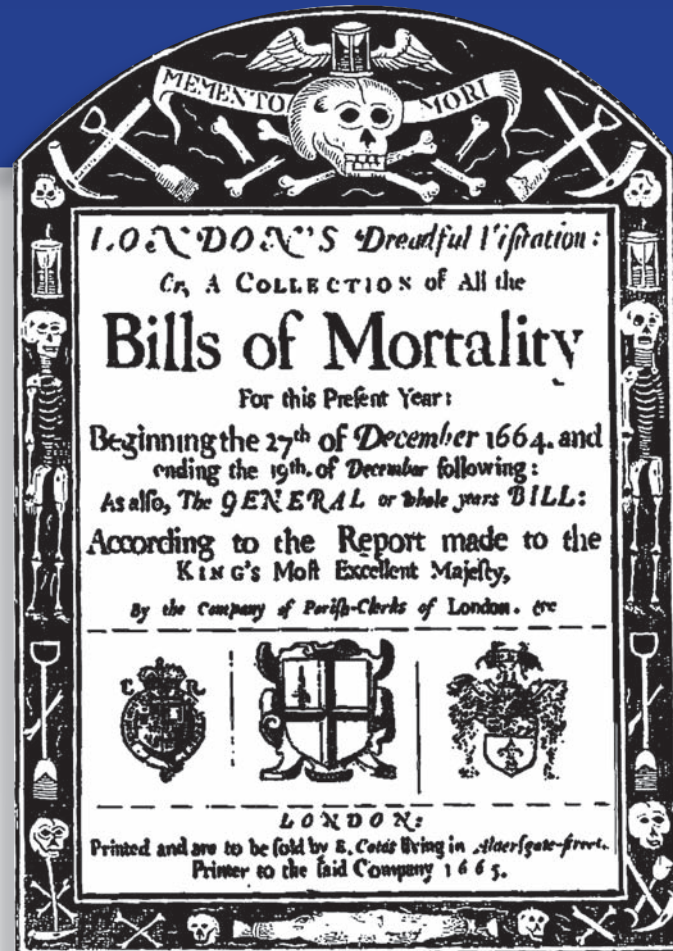

6.1

Tables and Pictographs

▶ Objectives

You should be able to:

A > Read and interpret the information in a table.

B > Read and interpret the information in a pictograph.

▶ To Succeed, Review How To . . .

1. Find the percent of a number. (pp. 318–319, 329)
2. Determine what percent of a whole is a given number. (pp. 318–319, 329)

▶ Getting Started

Which is your favorite fast-food restaurant? A national telephone survey of 1000 adults was conducted by Rasmussen Reports. The results can be shown several different ways. One way is to write how many persons regarded each of the four restaurants as favorable or unfavorable. A better and more efficient way would be to write the percent of adults who viewed each restaurant as favorable or unfavorable as shown in the table.

	Favorable	Unfavorable
Wendy's	73%	19%
McDonald's	66%	27%
Burger King	63%	29%
Kentucky Fried Chicken	62%	30%

Source: Data from Rasmussen Reports.

Note: Percents do not add up to 100% because of rounding or no response.

A > Reading and Interpreting Tables

Can we make any conclusions from the above data? The restaurant that was viewed as the *most* favorable among all adults surveyed was Wendy's, with a 73% rating. Which was the least *unfavorable*? Wendy's again!

Many practical situations require a compact and accurate summary of the information obtained. A **table** will present information in an efficient way by using rows and columns. Here is an example.

EXAMPLE 1 Interpreting a table: Computer games

The table shows the percent of people who play either computer or video games.

Who's Playing Games?		
	Computer Games	Video Games
Under 18	29.7%	37.9%
18–35	28.7%	39.5%
35+	41.6%	22.7%
Male	58.1%	71.5%
Female	41.9%	28.5%

Source: Data from ESA.

PROBLEM 1

Refer to the table and answer the following questions.

- a. What percent of the people under 18 play video games?
- b. What percent of the people 35 and over play computer games?
- c. Who plays more video games, males or females?

Answers to PROBLEMS

1. a. 37.9% b. 41.6% c. Males, 71.5% to 28.5%

- What percent of the people under 18 play computer games?
- What percent of the people 35 and over play video games?
- Who plays more computer games, males or females?

SOLUTION 1

- The *first* row under “Computer Games” (column 2) indicates that 29.7% of the people under 18 play computer games.
- The *third* row under “Video Games” (column 3) indicates that 22.7% of the people 35 and over play video games.
- The percent of males who play “Computer Games” (column 2, row 4) is 58.1%, while the percent of females is 41.9%. Thus, more males play computer games.

EXAMPLE 2 Interpreting a table

The table shows the number of crashes classified by severity (fatal, injury, or property damage) and by the month.

Crash Severity				
	Fatal	Injury	Property Damage	Total Crashes
Month	Number	Number	Number	Number
January	2,935	147,000	413,000	562,000
February	2,591	144,000	332,000	478,000
March	2,869	154,000	336,000	493,000
April	3,015	150,000	320,000	473,000
May	3,426	160,000	335,000	499,000
June	3,320	157,000	342,000	503,000
July	3,490	155,000	333,000	491,000
August	3,584	157,000	325,000	485,000
September	3,233	156,000	337,000	495,000
October	3,417	162,000	375,000	541,000
November	3,102	158,000	399,000	560,000
December	3,271	164,000	434,000	601,000
Total	38,253	1,862,000	4,281,000	6,181,000

Source: Vehicle miles traveled, Federal Highway Administration, *Traffic Volume Trends* (June 2005).

- In what month did the most **fatal** crashes occur?
- In what month did the fewest **injuries** occur?
- In what month did the most **crashes** occur?
- In what month did the fewest **crashes** occur?

SOLUTION 2

- The second column shows the number of fatal crashes. The highest number in that column is **3584** and it occurred in **August**.
- The third column shows the number of injuries. The smallest number in the column is **144,000** occurring in **February**.
- The last column shows the total number of crashes. In that column the highest number is **601,000** occurring in **December**.
- The fewest crashes showing in the last column occurred during **April, 473,000** crashes.

PROBLEM 2

Referring to the table:

- In what month did the most accidents result in property damage?
- In what month did the fewest accidents result in property damage?
- In what month did the number of total crashes exceed 600,000?
- How many injury accidents occurred in March?



Answers to PROBLEMS

2. a. December b. April c. December d. 154,000

B > Reading and Interpreting Pictographs

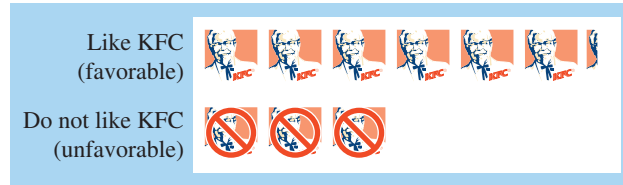
The information in the preceding tables can also be summarized by using a **pictograph**, a type of graph that uses symbols to represent numerical data in a statistical or financial graph, with each value represented by a *proportional* number or size of pictures. Thus, if we want to show the fact that 62 people like Kentucky Fried Chicken but 30 do not, we can make a pictograph that looks like this:



 = 10 people who like KFC
 = 10 people who do not like KFC

GREEN MATH

EXAMPLE 3 Interpreting a pictograph: bulb life

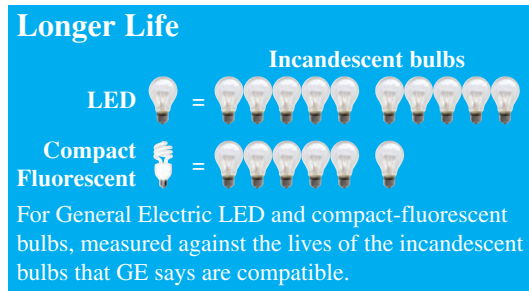

Source: General Electric (*Wall Street Journal*, May 29, 2009, p. A11).

The pictograph shows the expected lifetime of a light-emitting diode (LED) bulb and a compact fluorescent lightbulb (CFL) as compared to an incandescent (standard) bulb. How much longer than a standard bulb does the LED bulb last?

SOLUTION 3

The life of an LED is equivalent to **10** times the life of an incandescent (standard) bulb.

PROBLEM 3

How much longer than a standard bulb does the CFL last?

Note that the graph does not specify how many hours each of the bulbs last, how much electricity they consume, or how much they cost! A CFL has a rated lifespan of 6000–8000 hours, saves \$38 a year in electricity, and costs under \$2.

EXAMPLE 4 Interpreting a pictograph: Cola preferences

The pictograph shows the number of students attending the specified event whose number-one soda choice was ACE cola.

If  represents 100 students, how many students chose ACE cola as their number-one choice at the specified event?

- at the dance
- at the party







PROBLEM 4

Referring to the pictograph, how many students chose ACE cola as their number-one choice at the game?

Answers to PROBLEMS

3. Six times 4. 250

SOLUTION 4

- a.  students chose ACE cola as their number-one choice at the dance. Since  = 100 students,  = $3 \cdot 100 = 300$ students.
- b. Since  = 100 students,  = $\frac{1}{2}$ of 100 = 50 students. Thus,  = $300 + 50 = 350$ students.



EXAMPLE 5 Interpreting a pictograph: Online courses







Have you taken a course online? The information in the pictograph is based on a survey of 144 students done by the University of Phoenix.



Source: University of Phoenix Online.

- a. How many students are executives or business owners?
 b. Which category has the most students?
 c. How many students are technical or licensed professionals?

SOLUTION 5

- a. Since  = 10 executives or business owners,  means that there are 20 executives or business owners.
- b. The category with the most students (9  and ) is technical or licensed professionals.
- c. There are 9  = 90 and  = 4. Thus, there are 94 technical or licensed professionals. Note that the survey consisted of 144 students, so  = 4.

PROBLEM 5

Referring to the pictograph:

- a. How many students are middle managers?
 b. Which category has the fewest students?

Answers to PROBLEMS

5. a. 30
 b. Executives or business owners

> Exercises 6.1

< A > Reading and Interpreting Tables

Restaurants Refer to the table for Problems 1–4.

- Which restaurant was viewed as the *most* favorable among the investors?
- Which restaurant was viewed as the most unfavorable among the investors?
- What percent of the investors viewed McDonald's as favorable?
- What percent of the investors viewed Burger King as unfavorable?

Table for Problems 1–4

Among Investors	Favorable	Unfavorable
Wendy's	75%	18%
McDonald's	69%	26%
Kentucky Fried Chicken	66%	28%
Burger King	62%	31%

Source: Data from Rasmussen Reports.

Software The table shows the number of students and professors who pay for the software they download.

- How many students pay every time?
- How many students never pay?
- How many professors pay every time?
- How many more professors than students pay every time?
- In what category is the number of students and professors the same?
- Which category has the largest difference between students and professors?

Table for Problems 5–10

	Students	Professors
Every time	22	94
Most times	42	42
Seldom	52	32
Never	84	32

Source: Data from Ipsos and ClickZ Network.

E-mail The table shows the number and type of spam (unsolicited “junk” e-mail sent to large numbers of persons to promote products or services) received by the same 200 persons in July and August.

- Which type of spam has the largest increase from July to August?
- Which type of spam has the smallest (positive) increase from July to August?
- Which types of spam stayed the same in July and August?
- Which types of spam declined from July to August?
- Which type of spam has the largest decline from July to August?
- Which types of spam have the smallest decline from July to August?

Table for Problems 11–16

Type of Spam	July	August
Internet	14	22
Other	28	32
Scams	18	20
Products	40	40
Spiritual	2	2
Financial	30	28
Leisure	16	14
Adult	28	24
Health	24	18

Source: Data from Erightmail's Probe Network and ClickZ Network.

< B > Reading and Interpreting Pictographs

Hours worked Refer to the clock pictograph on page 377 for Problems 17–22.

- How many hours did the classified employees work per week?
- How many hours did the professional-managerial employees work per week?

The pictograph represents the number of hours worked per week by classified, professional-managerial, and administrative employees, respectively. Assume each symbol represents 10 hours.

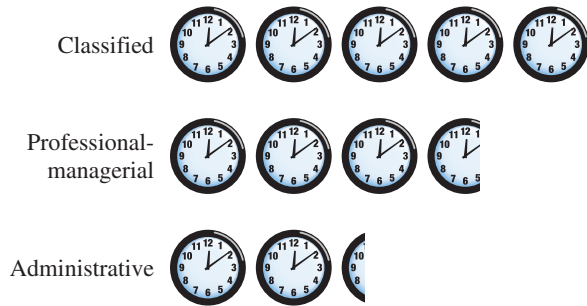

Internet The following information will be used in Problems 23–30.

ComScore Media Metrix reported the number of unique visitors (each visitor is only counted once) in a recent month. Each symbol represents 10 million visitors.

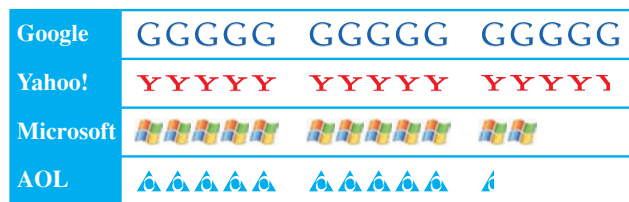

By the way, Facebook, MySpace, and Twitter had 112, 57, and 20 million unique visitors, respectively.

- How many hours did the administrative employees work per week?
- Which employees worked the most hours per week?
- Which employees worked the fewest hours per week?
- If employees get overtime pay for hours worked over 40, which employee category gets overtime pay?

- Which company had the most users?
- Which company had the fewest users?
- How many users did Yahoo! have?
- How many users did AOL have?
- How many users did Google have?
- What was the difference in the number of users between Microsoft and AOL?
- What was the difference in the number of users between AOL and Yahoo!?
- What was the difference in the number of users between Yahoo! and Google?

Applications: Green Math

What items do you recycle at home? The graph shows the recycling rates as a percent for several items (categories).

- Which is the most recycled item?
- Which is the least recycled item?
- What percent of magazines is recycled?
- What is the percent difference in the recycling rate of steel cans and aluminum beer and soft drink cans?
- What is the percent difference in the recycling rate of plastic soft drink bottles and HDPE (high-density polyethylene) milk and water bottles?
- Americans buy 28 billion plastic water bottles every year and 8 out of 10 of them end up in a landfill. How many bottles is that?

Note: Recycling 1 ton of plastic saves 7.4 cubic yards of landfill space and recycling 1 ton of paper saves 3.3 cubic yards of landfill space.

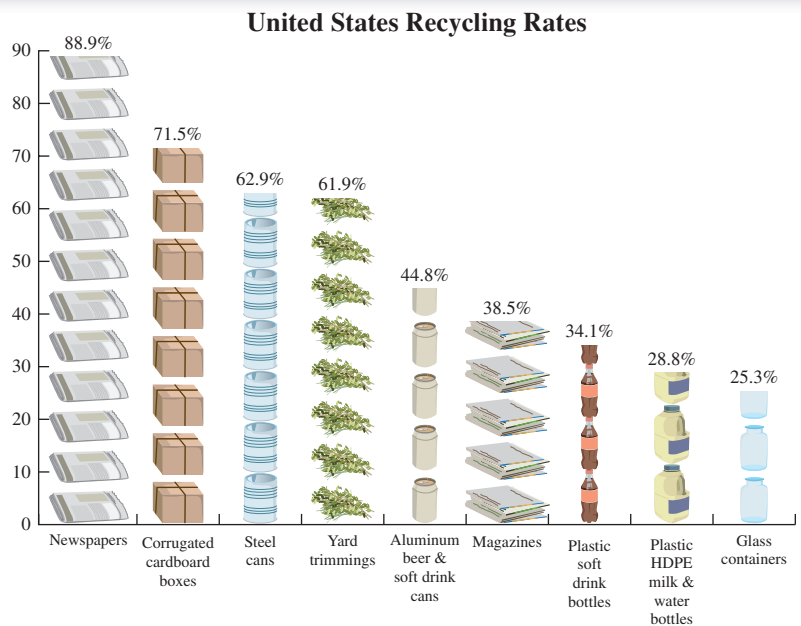

Source: <http://boonevillerecycles.googlepages.com/barcrecyclingfacts>.

Using Your Knowledge

Nutrition The knowledge we have gained in this section can be used to follow sound nutritional habits. Once in a while, however, we may deviate from the plan and eat cheeseburgers! Here is the nutritional information for five different restaurant cheeseburgers:

Nutritional Info	Burger King	Del Taco	Jack in the Box	McDonald's	Wendy's
Calories	360	330	360	330	310
Fat	17 g	13 g	18 g	14 g	12 g
Sodium	805 mg	870 mg	740 mg	800 mg	820 mg
Cholesterol	50 mg	35 mg	60 mg	45 mg	45 mg

Source: Data from Fast Food Source.com.

37. Which restaurant's cheeseburger has the fewest calories? 38. Which restaurant's cheeseburger has the most calories?
39. If you are on a low-sodium diet, which cheeseburger should you select? 40. If you are on a low-fat diet, which cheeseburger should you select?

Write On

41. Write in your own words the advantages and disadvantages of representing data using pictographs. 42. Write in your own words the advantages of using a table instead of a pictograph to present data.

Concept Checker

Fill in the blank(s) with the correct word(s), phrase, or mathematical statement.

43. A _____ presents information by using rows and columns. pictograph bar graph
44. A _____ is a type of graph that uses symbols to represent the numerical data. table line graph

Mastery Test

Buying power The table illustrates the buying power by race and will be used in Problems 45–47.

45. Which race had the most buying power in 2008?
46. Which race will have the least buying power in 2013?
47. What would be the difference in buying power between 2008 and 2013 for Asians?

U.S. Buying Power by Race (billions of dollars)		
	2008	2013
White	9135.7	11,796.0
Black	913.1	1239.5
American Indian	61.8	84.6
Asian	509.1	752.3
Multiracial	101.2	141.2

Source: Data from Selig Center.

Transportation The pictograph shows the transportation method used by students to get to school and will be used in Problems 48–52. Each symbol represents one student in a class.

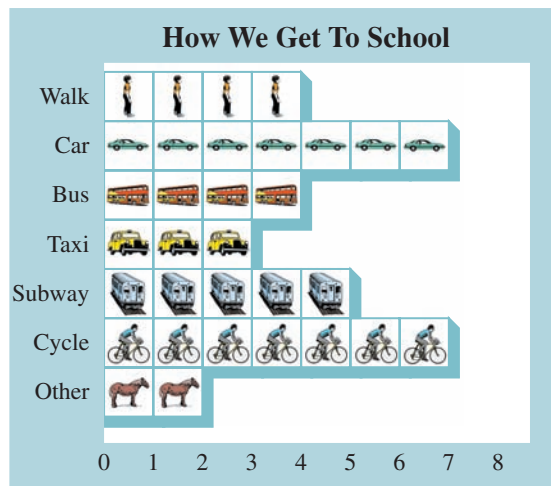

Source: Data from SPA.

48. Which is the least-used form of transportation?
49. How many students come by car?
50. How many students walk?
51. Find the difference between the number of students who cycle and those who walk.
52. If each symbol represents 100, how many students come by taxi?

>>> Skill Checker

In Problems 53–58, find:

53. 2% of 725.

54. 4% of 725.

55. 70% of 725.

56. $\$498 - \401 .

57. $34\% - 9\%$.

58. $28\% - 8\%$.

6.2

Bar and Line Graphs

▶ Objectives

You should be able to:

A > Read and interpret the information in bar graphs.

B > Draw bar graphs.

C > Read and interpret the information in line graphs.

D > Draw line graphs.

▶ To Succeed, Review How To . . .

Add, subtract, multiply, and divide whole numbers. (pp. 24–30, 38–43, 50–55, 64–66)

▶ Getting Started

The **bar graphs** here compare at a glance the outcome of giving a medicine to patients. A recent milestone study regarding hormone replacement therapy for relieving the effects of menopause showed that there were more *risks* than *benefits* in the treatment. The people who conducted the survey persuaded doctors to stop the experiments by displaying the statistics using bar and line graphs. Let us look at the first graph labeled Risks. In this graph, the red bars (women who took the medicine) are always *longer* than the blue bars (women who took a placebo: fake medicine), indicating that more women taking the medicine had heart attacks, strokes, breast cancer, and blood clots. For example, the red bar in the heart attack category is about 37 units long (see the scale on the left: 0, 10, 20, 30, 40, 50, 60), while the blue bar is about 30 units long. This means that 37 women (out of 10,000) suffered a heart attack while taking the medicine but only 30 (out of 10,000) suffered heart attacks when taking the placebo. We shall look at the numbers for strokes, breast cancer, and blood clots in the examples.

Hormone Replacement Therapy

The most popular prescription for relieving the effects of menopause has more risks than benefits, and the 6 million women in the United States who take the estrogen-plus-progestin preparation should consult their doctors right away, a national study determined. The research found these numbers of illnesses per 10,000 women annually.

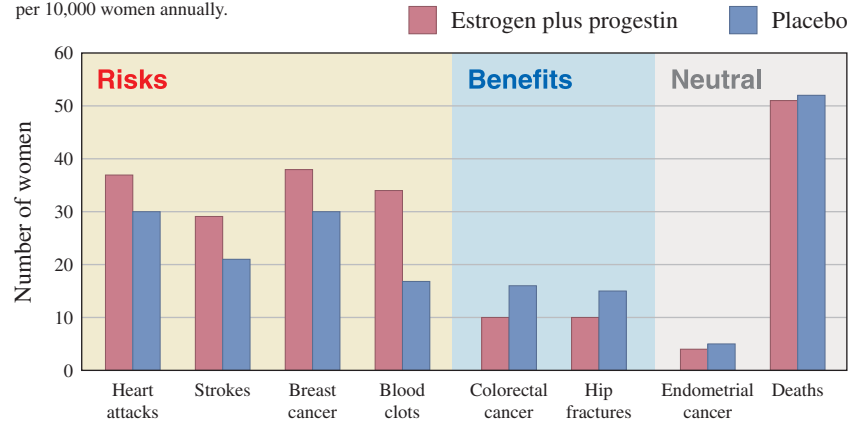

Source: Data from *Journal of the American Medical Association*.

A > Reading and Interpreting Bar Graphs

A **bar graph** is a convenient way of comparing different categories by using bars whose lengths are *proportional* to the number of items in the category. In the graph labeled **Risks**, the first category is Heart Attacks and the second category is Strokes. If you look at the vertical scale 0, 10, 20, 30, 40, 50, 60, you can see that the red bar over the Strokes category is about 29 units long, while the blue bar is about 21 units long. This means that 29 women (out of 10,000) suffered a stroke while taking the medicine but only 21 (out of 10,000) had a stroke while taking the placebo.

EXAMPLE 1 Interpreting bar graphs

Refer to the graph labeled **Risks** in order to answer the following questions.

- How many women (out of 10,000) reported breast cancer while taking the medicine?
- How many women (out of 10,000) reported breast cancer while taking the placebo?
- How many more women reported breast cancer while taking the medicine?

SOLUTION 1

- The red bar over the Breast cancer category, representing the women who took the medicine, is about 38 units long. This means that 38 women reported breast cancer while taking the medicine.
- The blue bar is 30 units long. This means that 30 women reported breast cancer while taking the placebo.
- $38 - 30 = 8$ more women (out of 10,000) reported breast cancer while taking the medicine.

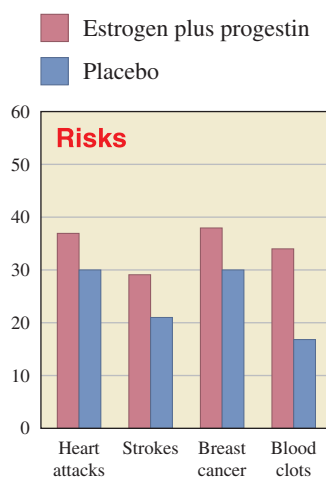

Source: Data from *Journal of the American Medical Association*.

PROBLEM 1

Refer to the graph labeled **Risks** to answer the following questions.

- How many women (out of 10,000) reported blood clots while taking the medicine?
- How many women (out of 10,000) reported blood clots while taking the placebo?
- How many more women reported blood clots while taking the medicine?

We have used vertical bars in our graphs. Sometimes, horizontal bars are also used. In such cases, the *categories* (what kind of item?) may be on the vertical or *y*-axis while the *frequencies* (how many items?) may be on the horizontal or *x*-axis. Learning all this may earn you a vacation. So, where will you go? Let us look at Example 2.

Answers to PROBLEMS

1. a. About 34 b. About 17
c. 17

EXAMPLE 2 Interpreting bar graphs

The horizontal bar graph tells you where vacationers are headed. Both the categories (Scenic drive, Beach or lake, Big city, and Small town) and the frequencies are shown horizontally.

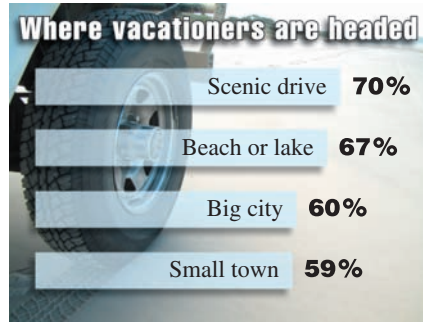

Source: Data from Travel Industry Association of America (TIA).

- a. Which is the most frequent destination and what percent of the people select it?
- b. Which is the least frequent destination and what percent of the people select it?

SOLUTION 2

- a. The most frequent destination is the scenic drive, chosen by 70% of the people.
- b. The least frequent destination is a small town, and 59% of the people select it.

PROBLEM 2

Refer to the graph and answer the following questions.

- a. Which is the second most frequent destination, and what percent of the people select it?
- b. Which is the second least frequent destination, and what percent of the people select it?

B > Drawing Bar Graphs

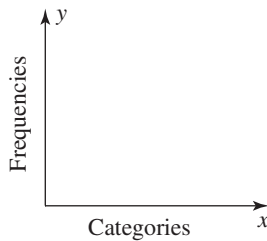

Now that we know how to read and interpret bar graphs, we should be able to draw our own. (After you learn how to do it, you can use commercial software, such as Excel, to draw it for you!) Let us start with vertical bar graphs, the ones in which the categories are on the horizontal or *x*-axis and the frequencies appear on the vertical or *y*-axis. They should look like the one shown here.

Now, you may be embarrassed if you cannot do vertical bar graphs, but what would embarrass you the most on your first date? Read on and find out.

EXAMPLE 3 Drawing a vertical bar graph

What would embarrass you the most on your first date? Draw a vertical bar graph using the following data.

Bad breath (BB)	40%
Acne breakout (AB)	23%
Fly open (FO)	22%
Greasy hair (GH)	14%

Source: Data from Wirthlin Worldwide for Listerine.

SOLUTION 3 To identify the graph, we label it “First-Date Blunders.” We have four categories represented in the horizontal axis. The frequencies go from 14 to 40, so we make the vertical axis go from 0 to 50 at 10-unit intervals as shown.

The bars are 40, 23, 22, and 14 units long, corresponding to the percents given in the table.

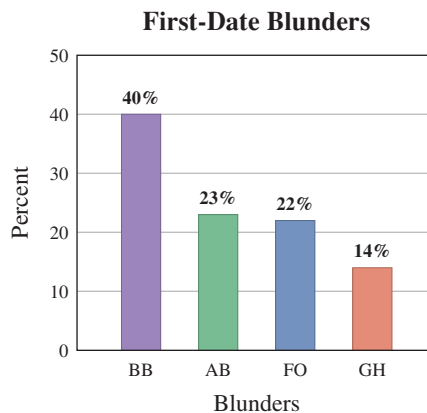

PROBLEM 3

Are you stressed out yet? What caused it? According to a survey by CyberPulse for Wrigley Healthcare’s Surpass, the most common causes for stress are as shown:

Money (M)	49%
Family responsibilities (FR)	22%
Work deadlines (WD)	22%
Commuting (C)	7%

Draw a vertical bar graph using this data.

Answers to PROBLEMS

- 2. a. Beach or lake; 67%
- b. Big city; 60%

3. What Stresses Us Out

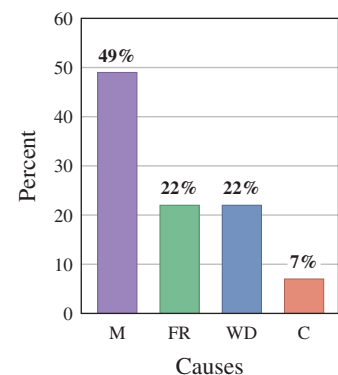

What about horizontal bar graphs? The procedure for drawing such graphs is very similar, and we illustrate it next.

EXAMPLE 4 Drawing a horizontal bar graph

Have you had the flu lately? Where did you catch it? Here are the places where germs thrive in the office. Draw a *horizontal* bar graph for the data.

Telephones (T)	29%
Doorknobs (D)	28%
Restrooms (R)	24%

Source: Data from Opinion Research for Kimberly Clark.

SOLUTION 4 We title the graph “Where Office Germs Thrive.” This time we place the categories (T, D, and R) on the vertical axis and the frequencies on the horizontal axis. Because the frequencies range from 24 to 29, we make the horizontal scale go from 0 to 40 at 10-unit intervals. To make the work easier, we insert vertical dashed lines at 10-unit intervals. The graph is shown.

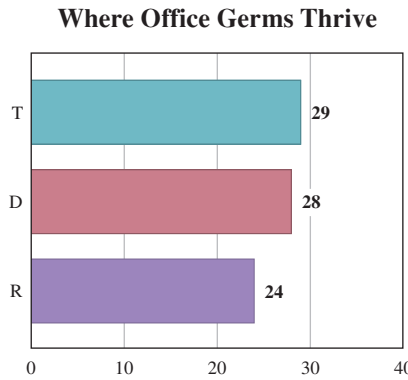

PROBLEM 4

What things do drivers keep in their cars? Here is the answer, according to a survey by Roper ASW done for Allstate.

Tapes/CDs (TCD)	72%
Umbrellas (U)	59%
Money (M)	36%
Clothes (C)	26%

Draw a horizontal bar graph for this data.

C > Reading and Interpreting Line Graphs

As we mentioned before, bar graphs are most useful when we wish to *compare* the frequency of different categories. If we want to show a trend or a change over time, then we use **line graphs**. Thus, to compare tuition and fee charges in 4-year private, 4-year public, and 2-year public colleges from 1978 to 2009, we use the line graphs shown.

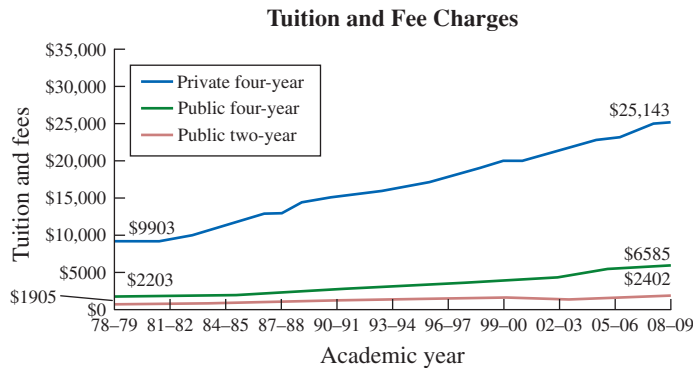

Sources: The College Board. *Annual Survey of Colleges*, National Center for Education Statistics (NCES), *Integrated Postsecondary Education Data Systems*.

Answers to PROBLEMS

4.

Things in the Car

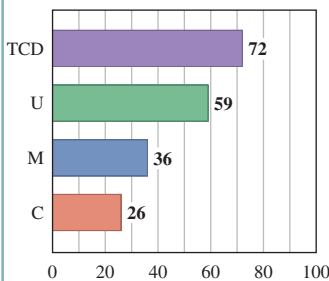

As you can see, in 2008–2009 the most expensive tuition was at private four-year colleges: \$25,143. The least expensive was at public two-year colleges: \$2402. A crucial question for you is: How much can you save by attending a public two-year college rather than a private four-year one? To see more prices, see Problem 24 in the Exercises.

EXAMPLE 5 Interpreting line graphs

Remember the study mentioned in the *Getting Started* section? The four line graphs **below** relate the *risk* of some illnesses (*vertical scale*, from 0 to 0.03) and the *length* of time the women have taken the medicine (*horizontal scale*, from 0 to 7 years).

- Study the graphs and determine in which years (to the nearest year) the placebo group (blue) had fewer **heart attacks** than the medicine group (red).
- Study the graphs and determine in which years (to the nearest year) the placebo group had fewer **blood clots** than the medicine group.
- Which was the only condition in which the patients taking the medicine fared better than the ones taking the placebo?

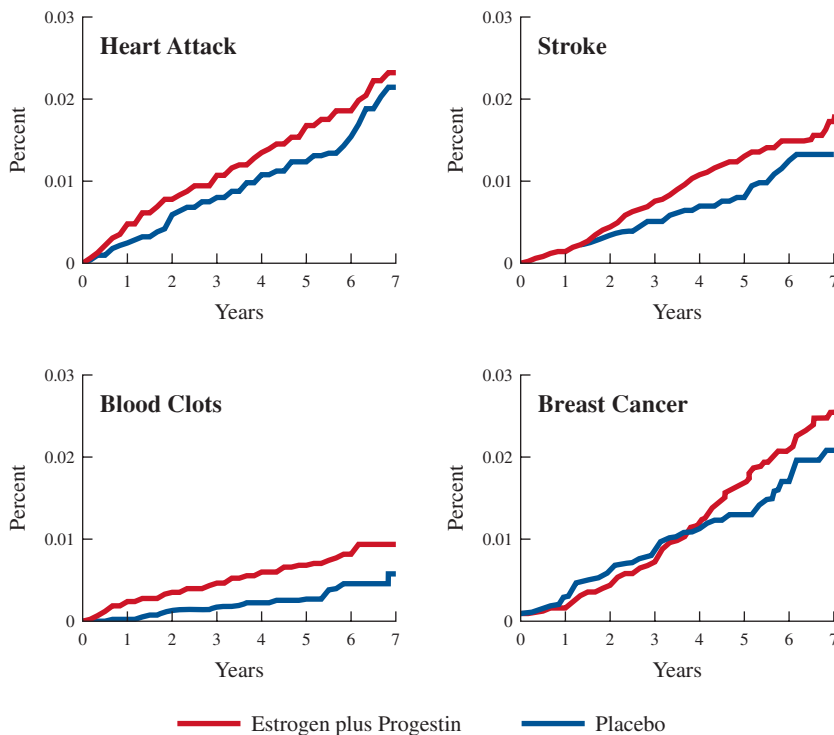

Source: Data from *Journal of the American Medical Association*.

SOLUTION 5

- From 0 to 7
- From 0 to 7
- Breast cancer (but only years 1–4)

PROBLEM 5

Refer to the graphs and answer the following questions.

- In what years (to the nearest year) did the placebo group have fewer strokes than the medicine group?
- In what years (to the nearest year) did the placebo group have fewer breast cancers than the medicine group?
- In what years and in which condition were the patients taking the medicine better off than the ones taking the placebo?

D > Drawing Line Graphs

Now that we know how to interpret line graphs, we should be able to draw our own. We shall do so next.

Answers to PROBLEMS

- 1 to 7
 - 4 to 7
 - Breast cancer patients are better off when taking the medicine in years 1 to 4.

GREEN MATH

EXAMPLE 6 It is all garbage and we did it!

The table shows the number of **pounds** of garbage produced per person, per day in the United States between 1980 and 2010. Make a line graph of this data.

Year	Amount (pounds)
1980	3.7
1990	4.5
2000	4.7
2010	5.3 (estimate)

SOLUTION 6 The categories (years **1980, 1990, 2000, and 2010**) are on the horizontal axis and the amounts (3.7, 4.5, 4.7, and 5.3) are on the vertical axis. For convenience, we use a one unit scale on the vertical axis. To graph the point corresponding to 1980, we start at 1980, go up 3.7 units, and graph (1980, 3.7). For 1990, we go to 1990, go up 4.5 units, and graph (1990, 4.5). We do the same for 2000 and 2010. Finally, we join the points with line segments as shown in red.

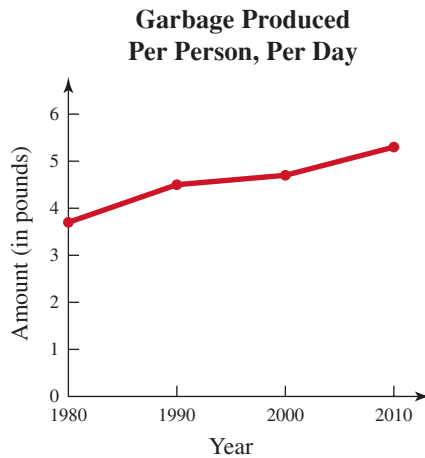

Source: <http://www.epa.gov/epawaste/nonhaz/municipal/pubs/msw06.pdf>.

PROBLEM 6

The table shows the amount of garbage (in millions of tons) produced annually in the United States between 1980 and 2010. Make a line graph of this data.

Year	Amount (millions of tons)
1980	150
1990	205
2000	240
2010	285 (estimate)

> Exercises 6.2



- > Practice Problems > Self-Tests
- > Media-rich eBooks > e-Professors > Videos

< **A** > **Reading and Interpreting Bar Graphs** In Problems 1–13, answer the questions by interpreting the bar graphs.

1. **Medicine** Refer to the graph labeled **Benefits**. How many women (out of 10,000) reported colorectal cancer
 - a. while taking the medicine (red)?
 - b. while taking the placebo (blue)?
 - c. Which is better, to take the medicine or to take the placebo?

Answers to PROBLEMS

6. **Garbage Produced**

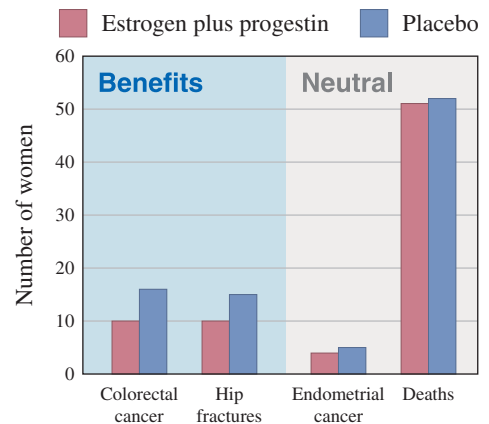
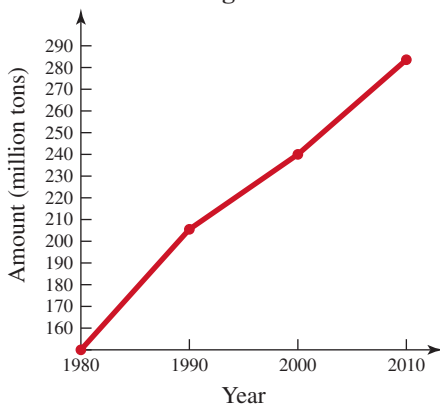

Source: Data from *Journal of the American Medical Association*.

2. *Medicine* Refer to the graph labeled **Benefits**. How many women (out of 10,000) reported hip fractures
- while taking the medicine (red)?
 - while taking the placebo (blue)?
 - Which is better, to take the medicine or to take the placebo?
4. *Medicine* Refer to the graph labeled **Neutral**. How many women (out of 10,000) died
- while taking the medicine (red)?
3. *Medicine* Refer to the graph labeled **Neutral**. How many women (out of 10,000) reported endometrial cancer
- while taking the medicine (red)?
 - while taking the placebo (blue)?
 - Which is better, to take the medicine or to take the placebo?
-
- while taking the placebo (blue)?
 - Which is better, to take the medicine or to take the placebo?

Problems 5–7 refer to the graph below:

Back to School Spending

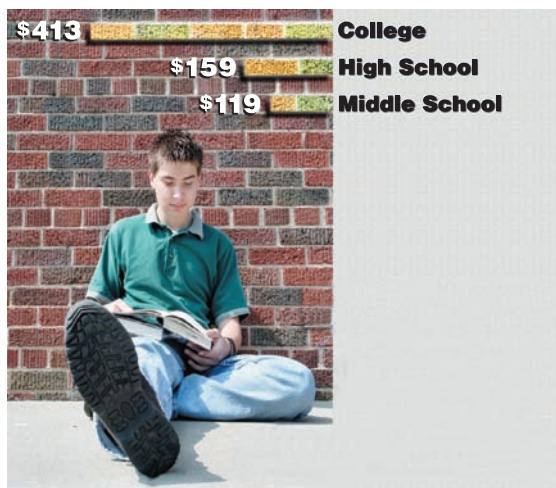

Source: Data from ICR for Capital One.

- Spending* Which of the three categories spends the most going back to school? How much do they spend?
- Spending* Which of the three categories spends the least going back to school? How much do they spend?
- Spending* What is the difference in spending between college and middle school students?

Problems 8–10 refer to a survey by *Business Week* of 725 employees.

8. *Stress* How great is the amount of stress you feel at work? The 725 employees surveyed by *Business Week* had these answers:
9. *Stress* The same 725 employees were asked if the stress was affecting their health. Here are the results:

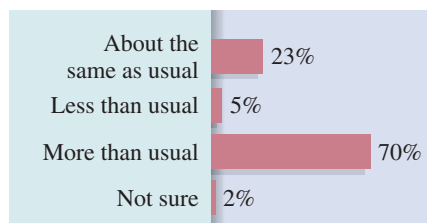

- Which was the most common response?
- What percent felt “About the same as usual”?
- What percent was “Not sure”?
- How many out of the 725 were not sure about how great the amount of stress they felt at work was? (Round the answer up.)

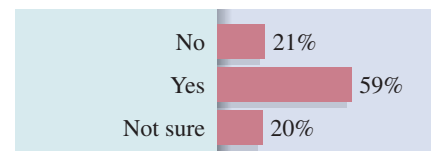

- What percent thought the stress was affecting their health?
- What percent was not sure?
- How many out of the 725 were not sure if stress affected their health?

10. Education Here is the educational attainment of the 725 employees surveyed:

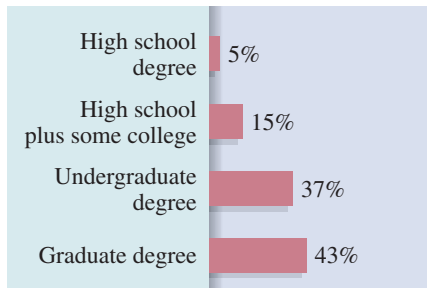

Source: Business Week Online.

- Which category had the most employees?
- What percent of the employees had only a high school degree?
- What percent of the employees had graduate degrees?
- How many of the 725 employees had graduate degrees?

12. Traffic fatalities At what time do fatal accidents occur? Look at the graph!

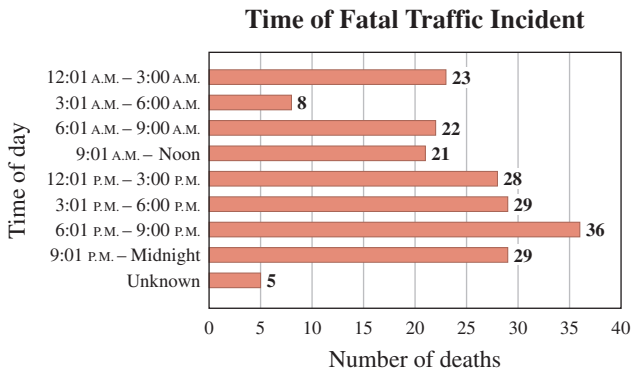

Find the number of fatalities between:

- 12:01 A.M. and 3:00 A.M.
- 3:01 A.M. and 6:00 A.M.
- What is the most likely time period for a fatal traffic incident?
- Aside from “unknown,” what is the least likely time period for a fatal traffic incident?

11. Traffic fatalities The graph shows the number of traffic fatalities and the age groups of the decedents.

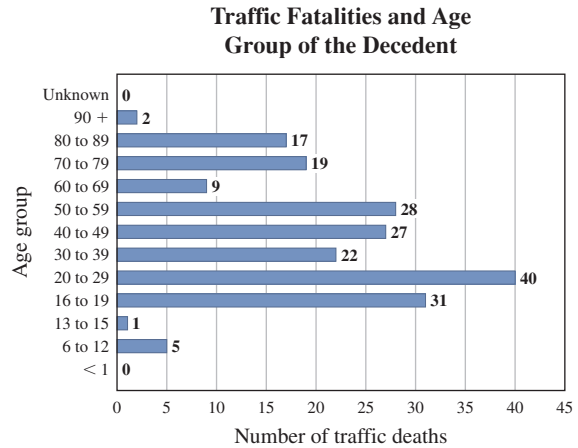

- Which age group has the most fatalities?
- Which age group has the fewest fatalities? Why do you think that is?
- Are there more fatalities involving people that are less than 50 years old or more than 50 years old?
- Which age group had only two fatalities? Why do you think that is?

13. Blood alcohol levels The bar graph shows the number of traffic fatalities and the blood alcohol level (BAL) of the driver.

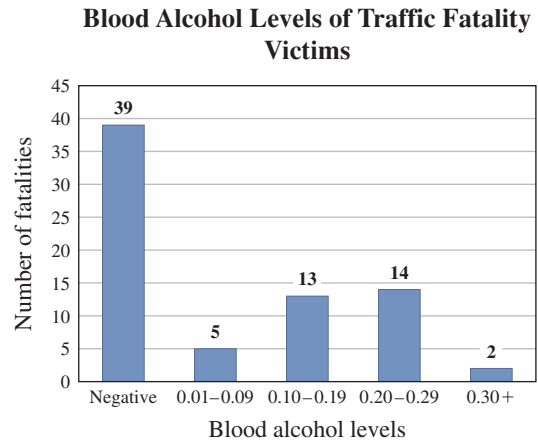

Source: Data from King County Government, Seattle, WA.

- What was the number of fatalities with a negative (0%) BAL?
- In many states, a person is legally drunk if their BAL is 0.10 or more. How many people were legally drunk? (In some other states 0.08 or more is legally drunk.)
- What was the most prevalent BAL for the people who were legally drunk? How many persons had that BAL?

For the latest reports, go to <http://tinyurl.com/ylq4mur>.

B Drawing Bar Graphs In Problems 14–18, answer the questions by drawing bar graphs.

14. Movies Do you go to the movies often? The survey shows the percent of people who go at least once a month.

Categories Age Bracket	Frequencies Percent
18–24	83%
25–34	54%
35–44	43%
45–54	37%
55–64	27%
65–up	20%

Source: Data from TELENATION/MarketFacts, Inc.

a. Draw a vertical bar graph for the data.

Movie Attendance by Age Group

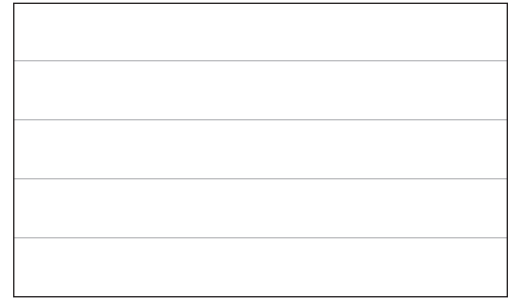

b. What age bracket goes to the movies the most frequently?

c. What age bracket goes to the movies the least?

15. Phone calls How many unwanted calls do you get daily? The number of unwanted calls received by the given percent of the people is shown.

Categories (Number of calls)	Frequencies
0	15%
1–2	41%
3–5	28%
6–up	12%

Source: Data from Bruskin/Goldring Research for Sony Electronics.

a. Draw a vertical bar graph for the data.

Unwanted Calls

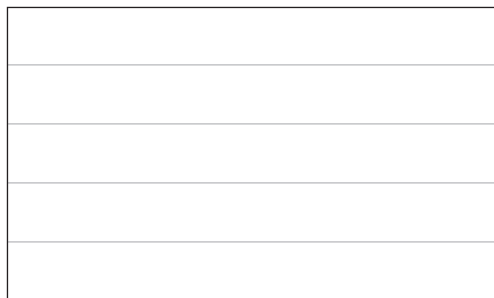

- b. Which is the most common number of calls received?
- c. What percent of the people received no unwanted calls?

16. Military Which branch of the military has the most women? A Defense Department survey shows the following numbers:

Categories (Branch)	Frequencies
Air Force	19.4%
Army	15.4%
Navy	14.4%
Marines	6%

a. Draw a horizontal bar graph of the data.

Women in the Armed Forces

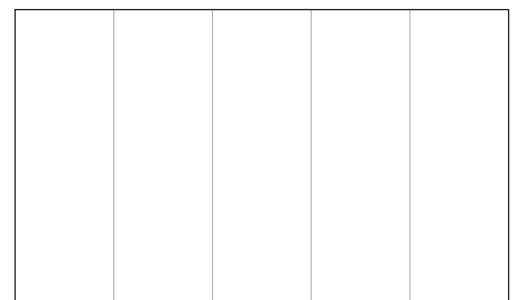

- b. Which branch has the highest percent of women?
- c. Which branch has the lowest percent of women?
- d. Can you use the information to find out if there are more women in the Air Force than in the Army? Explain.

- 17. Travel** Which is the most expensive city for business travel? A survey by Runzheimer International showed that the price for three meals and overnight lodging in business-class hotels and restaurants is as follows:

Categories (City)	Cost
London	\$498
Geneva	\$410
Moscow	\$407
Manhattan	\$401

- a. Draw a horizontal bar graph for the data.

Daily Travel Expenses

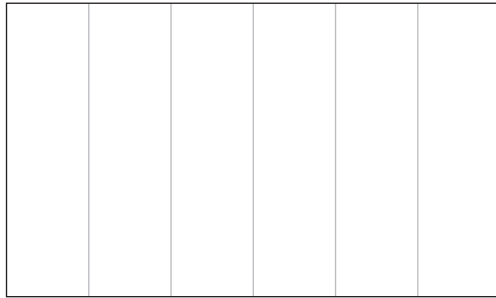

- b. Which is the most expensive city?
 c. Which is the least expensive city?
 d. What is the price difference between the most expensive and least expensive cities?

- 18. Internet** Who has the most Internet knowledge? A survey of *USA Today* adult respondents answering the question “Who has the most Internet knowledge?” revealed the following data:

Categories (Group)	Percent
Kids	72%
Adults	21%
Both the same	2%

- a. Draw a horizontal bar graph for the data.

Who Has the Most Internet Knowledge?

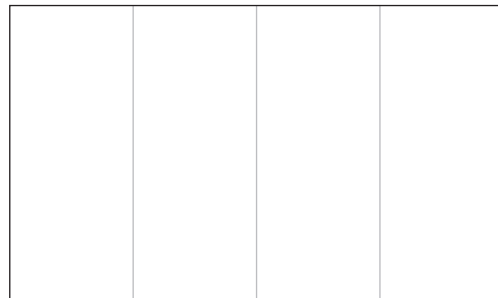

- b. According to the survey, who has the most knowledge?
 c. What percent of the people think that kids and adults have the same knowledge?

< C > Reading and Interpreting Line Graphs In Problems 19–24, answer the questions by interpreting the line graphs.

- 19. Unit price** The graph shows the average price per pound of fresh, whole chicken in five recent years.

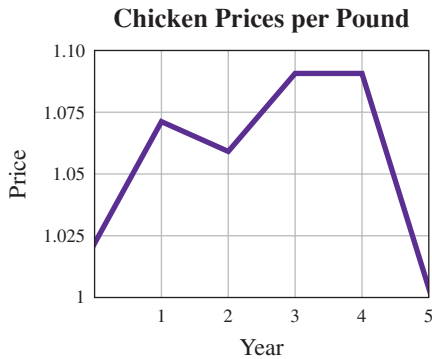

- a. In which years was the price highest?
 b. In what year was the price lowest?
 c. In what year was the price about \$1 a pound?

- 20. Unit price** The graph shows the average price per pound of whole wheat bread in five recent years.

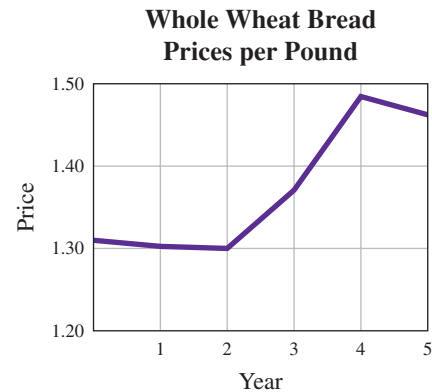

Source: Data from Bureau of Labor Statistics.

- a. In what year was the price highest?
 b. In what year was the price lowest?
 c. In what year was the price about \$1.30 a pound?

- 21. Sports** The rate of boys (blue) and girls (red) participating in high school sports is shown.
- What was the boys' rate of participation in 2001–2003?
 - What was the girls' rate of participation in 2001–2003?
 - What was the difference in the rate of participation between boys and girls in 2001–2003?
 - What was the difference in the rate of participation between boys and girls in 1980–1982?
 - Was the difference between the boys' and girls' rates of participation greater in 1980–1982 or in 2001–2003?

Although more boys continue to play high school sports than girls, the gender gap is getting smaller. A *USA TODAY* analysis has found that the rate of high school girls playing varsity sports continues on a slow but steady rise. The overall boys' participation rate has been flat during the same period.

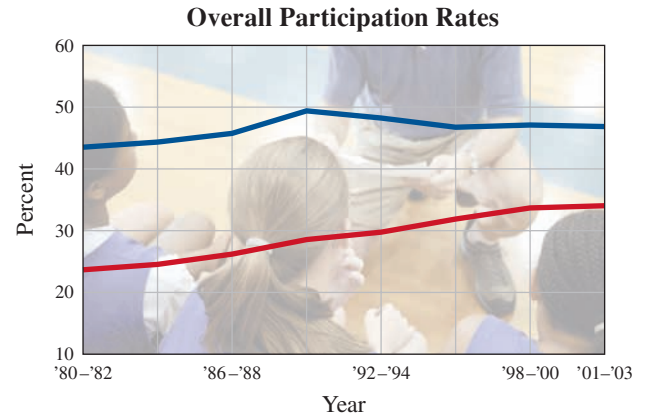

Average participation rates over three-year periods, calculated by comparing the average number of participants during the three years, divided by the average population of that gender, ages 14–17. If athletes participate in two or more sports during a given year, they are double or triple counted.

>>> Applications: Green Math

The graph shows the cost comparison between using a 60-W incandescent (regular) bulb costing about 25 cents, and a 13-W fluorescent bulb costing \$1.60 both used for 8 hours each day.

- What is the cost of running the incandescent bulb for
 - 10 days?
 - 23 days? (To the nearest dollar)
 - 30 days?
 - When is the incandescent cheaper?
- What is the cost of running the fluorescent bulb for
 - 10 days?
 - 23 days? (To the nearest dollar)
 - 30 days?
 - When are the costs the same?

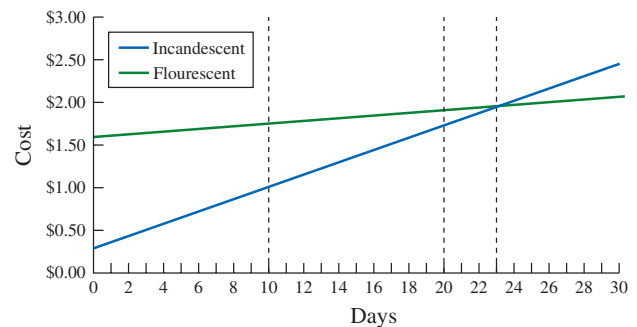

Source: <http://tinyurl.com/myf4tr>.

- Tuition expenses** The graph shows the annual cost of tuition, fees, and room and board (TFRB) for 4-year private institutions (blue line) and 4-year public institutions (green line).
 - What was the annual cost of TFRB for a 4-year private institution in 78–79?
 - What was the annual cost of TFRB for a 4-year public institution in 78–79?
 - What was the annual cost difference in TFRB between private and public institutions in 78–79?
 - What was the annual cost of TFRB for a 4-year private institution in 2008–09?
 - What was the annual cost of TFRB for a 4-year public institution in 2008–09?
 - What was the annual cost difference in TFRB between private and public institutions in 2008–09?

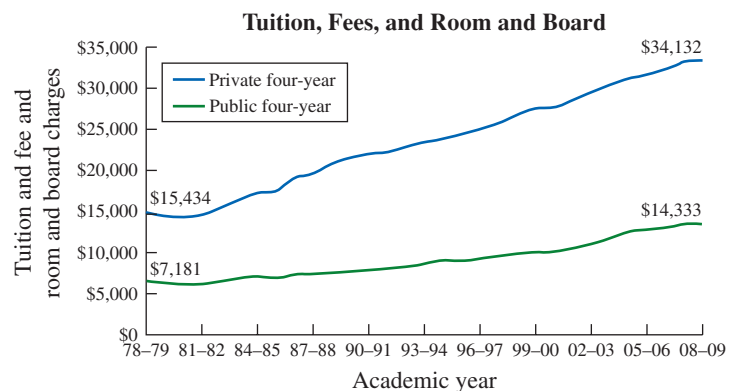

Sources: The College Board, *Annual Survey of Colleges*, National Center for Education Statistics (NCES), *Integrated Postsecondary Education Data Systems*.

< D > Drawing Line Graphs In Problems 25–40, make a line graph for the given data representing a recent 5-year period. (Data: U.S. Department of Labor, Bureau of Labor Statistics at <http://www.bls.gov>.)

How do you compare with these averages?

- 25. Clothing** The table shows the average amount of money spent on apparel by men between 16 and 25. Graph the data using 1–5 as the years and 200–300 as the amounts at \$10 intervals.

1	247
2	221
3	209
4	294
5	262

Average Amount of Money Spent on Apparel by Men Between 16 and 25

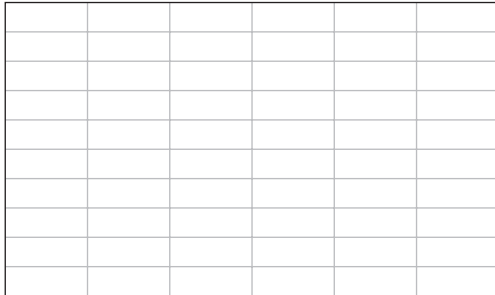

- 26. Clothing** The table shows the average amount of money spent on apparel by women between 16 and 25. Graph the data using 1–5 as the years and 350–450 as the amounts at \$10 intervals.

1	434
2	382
3	377
4	405
5	359

Average Amount of Money Spent on Apparel by Women Between 16 and 26

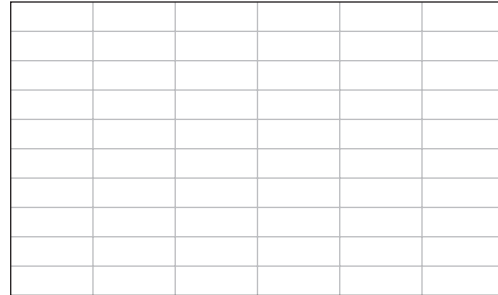

- 27. Food in general** The table shows the average amount of money spent on food by persons under 25. Graph the data using 1–5 as the years and 2600 to 4000 as the amounts at \$200 intervals.

1	2838
2	3075
3	3354
4	3213
5	3724

Average Amount of Money Spent on Food by Persons Under 25

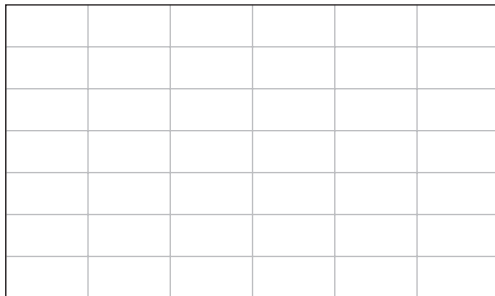

- 28. Food at home** The table shows the average amount of money spent on food at home by persons under 25. Graph the data using 1–5 as the years and 2500 to 3000 as the amounts at \$100 intervals.

1	2758
2	2547
3	2890
4	2951
5	2936

Average Amount of Money Spent on Food at Home by Persons Under 25

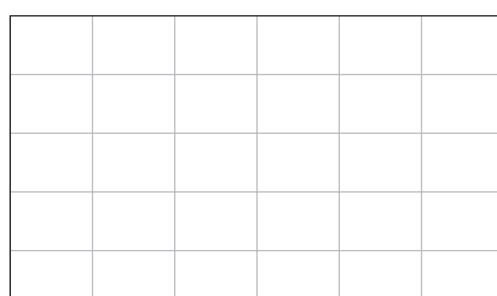

29. *Fresh fruit* The table shows the average amount of money spent on fresh fruit by persons under 25. Graph the data using 1–5 as the years and 120 to 150 as the amounts at \$5 intervals.

1	137
2	124
3	136
4	146
5	142

Average Amount of Money Spent on Fresh Fruit by Persons Under 25

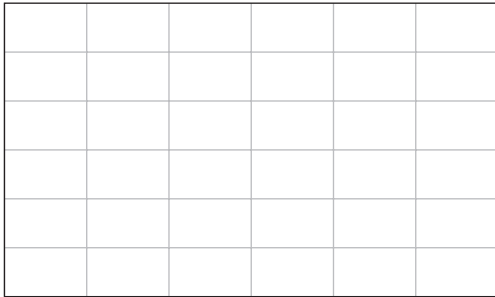

30. *Vegetables* The table shows the average amount of money spent on vegetables by persons under 25. Graph the data using 1–5 as the years and 120 to 150 as the amounts at \$5 intervals.

1	124
2	130
3	146
4	148
5	148

Average Amount of Money Spent on Vegetables by Persons Under 25

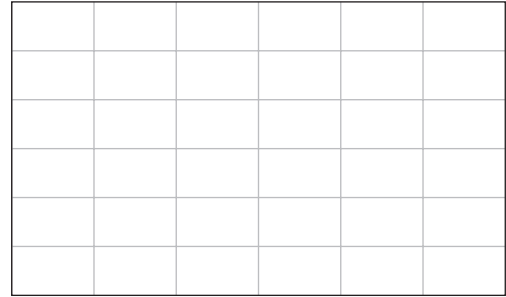

31. *Housing* The table shows the average amount of money spent on housing by persons under 25. Graph the data using 1–5 as the years and 5000 to 8000 as the amounts at \$500 intervals.

1	5860
2	6151
3	6585
4	7109
5	7585

Average Amount of Money Spent on Housing by Persons Under 25

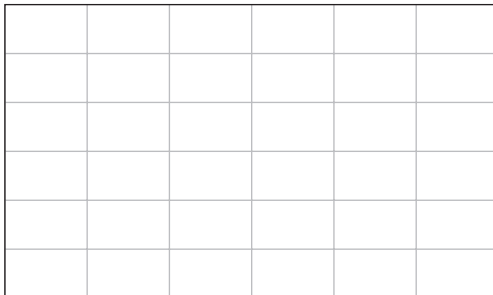

32. *Housing* The table shows the average amount of money spent on housing by persons between 25 and 34. Graph the data using 1–5 as the years and 11,000 to 14,000 as the amounts at \$500 intervals.

1	11,774
2	12,015
3	12,519
4	13,050
5	13,828

Average Amount of Money Spent on Housing by Persons Between 25 and 34

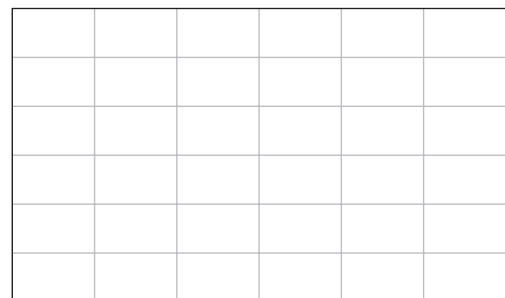

- 33. Entertainment** The table shows the average amount of money spent on entertainment by persons under 25. Graph the data using 1–5 as the years and 900 to 1200 as the amounts at \$50 intervals.

1	1051
2	974
3	1149
4	1091
5	1152

Average Amount of Money Spent on Entertainment by Persons Under 25

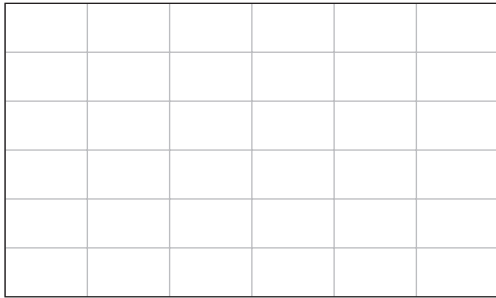

- 34. Entertainment** The table shows the average amount of money spent on entertainment by persons between 25 and 34. Graph the data using 1–5 as the years and 1700 to 2100 as the amounts at \$50 intervals.

1	1865
2	1757
3	1776
4	1876
5	2001

Average Amount of Money Spent on Entertainment by Persons Between 25 and 34

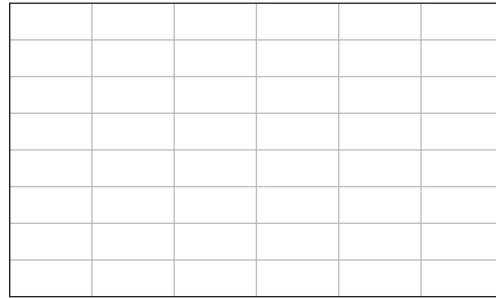

- 35. Health care** The table shows the average amount of money spent on health care by persons under 25. Graph the data using 1–5 as the years and 400 to 600 as the amounts at \$50 intervals.

1	425
2	445
3	551
4	504
5	530

Average Amount of Money Spent on Health Care by Persons Under 25

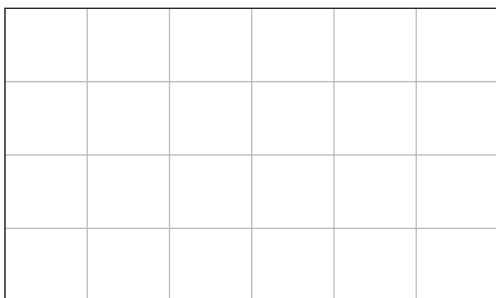

- 36. Health care** The table shows the average amount of money spent on health care by persons between 25 and 34. Graph the data using 1–5 as the years and 1000 to 1300 as the amounts at \$50 intervals.

1	1236
2	1185
3	1170
4	1256
5	1286

Average Amount of Money Spent on Health Care by Persons Between 25 and 34

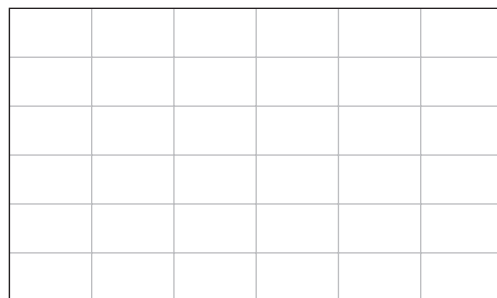

- 37. Wages-salaries** The table shows the average amount of annual wages-salaries earned by persons between 25 and 34. Graph the data using 1–5 as the years and 37,000 to 47,000 as the amounts at \$1000 intervals.

1	37,455
2	38,548
3	39,372
4	42,770
5	46,301

Average Amount of Annual Wages-Salaries Earned by Persons Between 25 and 34

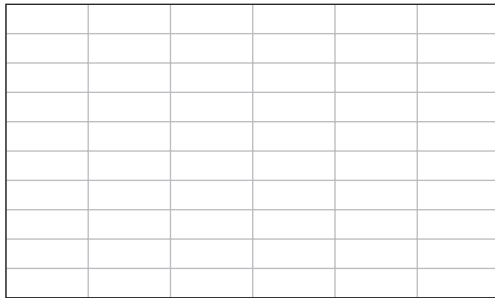

- 38. Wages-salaries** The table shows the average amount of annual wages-salaries earned by persons under 25. Graph the data using 1–5 as the years and 12,000 to 18,000 as the amounts at \$1000 intervals.

1	13,098
2	14,553
3	16,210
4	16,908
5	17,650

Average Amount of Annual Wages-Salaries Earned by Persons Under 25

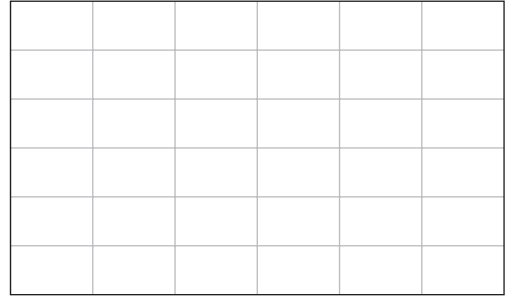

- 39. Income tax** The table shows the average amount of annual federal income taxes paid by persons between 25 and 34. Graph the data using 1–5 as the years and 2100 to 2700 as the amounts at \$100 intervals.

1	2567
2	2588
3	2316
4	2205
5	2266

Average Amount of Annual Federal Income Taxes Paid by Persons Between 25 and 34

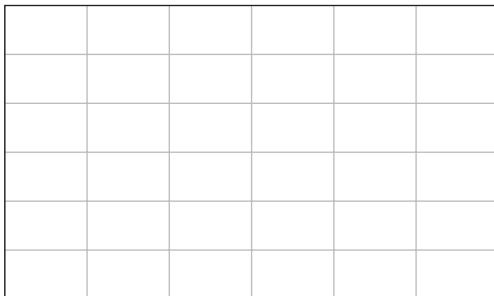

- 40. Income tax** The table shows the average amount of annual federal income taxes paid by persons under 25. Graph the data using 1–5 as the years and 200 to 800 as the amounts at \$100 intervals.

1	516
2	673
3	630
4	696
5	319

Average Amount of Annual Federal Income Taxes Paid by Persons Under 25

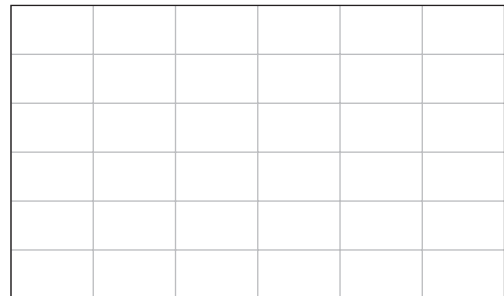

>>> **Using Your Knowledge**

Misuses of Statistics In this section, we have shown an honest way of depicting statistical data by means of a bar graph. But you can lie with statistics! Here is how. In a newspaper ad for a certain magazine, the circulation of the magazine was as shown in the graph. The heights of the bars in the diagram seem to indicate that sales in the first nine months were tripled by the first quarter of the next year (a whopping 200% rise in sales!).

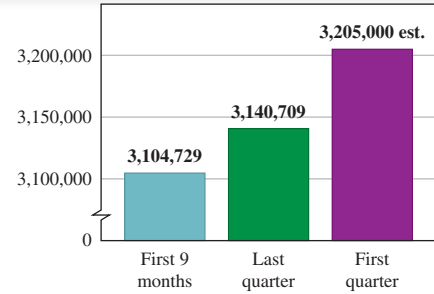

- 41. Find the approximate percent increase in sales from the first nine months to the first quarter of the next year. Was it 200%?
- 42. What was the approximate increase in the number of magazines sold?

>>> **Write On**

- 43. Explain in your own words what is wrong with the graph on the misuses of statistics in *Using Your Knowledge*.
- 44. Explain in your own words how statistics can be misused or misleading. Concentrate on examples involving bar and line graphs!

>>> **Concept Checker**

Fill in the blank(s) with the correct word(s), phrase, or mathematical statement.

- 45. A **bar graph** compares different categories by using bars whose lengths are _____ to the number of items in the category.
- 46. If we want to show a **trend** or **change over time**, we use _____ graphs.

bar
line
proportional
equal

>>> **Mastery Test**

- 47. *Insurance* The table shows the average annual amount of vehicle insurance paid by a driver less than 25 years old in five successive years. Graph the data using 1–5 as the years and 350 to 500 as the amounts at \$25 intervals.
- 48. *Toothpaste* The table gives the percent of males squeezing the toothpaste tube from the bottom, depending on their age. Draw a vertical bar graph for the data using the age group as the categories and the percents as the frequency at 10-unit intervals.

1	383
2	408
3	449
4	449
5	479

Average Amount of Vehicle Insurance Paid by a Driver Less Than 25 Years Old

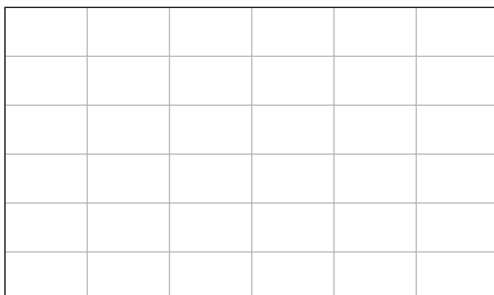

Age	Bottom (Percent)
21–34	37%
35–44	33%
45–54	10%
55+	10%

Percent of Males Squeezing the Toothpaste Tube from the Bottom

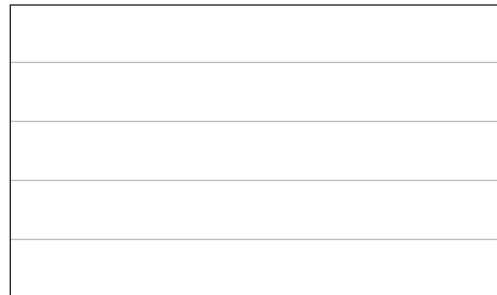

- 49. Age ranges** The table shows the projected percent of age ranges in the United States for the year 2050. Draw a horizontal bar graph of the data using the age brackets as the categories and the percents as the frequencies at 10-unit intervals.

Age	Percent
0–14	19%
15–64	62%
65+	19%

Projected Percent of Age Ranges in the United States for the Year 2050

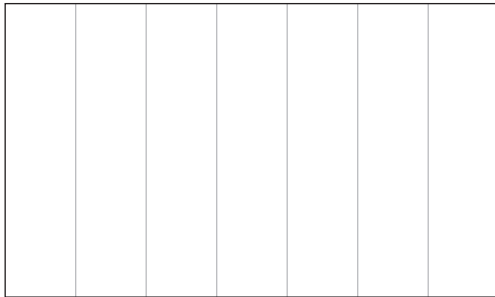

- 50. Customer preferences** The bar graph shows the customers' preferences for other services desired from ATMs.
- Which other service is the most desired?
 - Which is the least-desired service?



- 51. Economics** Are economic conditions getting better or worse? Use the line graph to answer the following questions.
- What percent of the people answered better on October 6–8?
 - What percent of the people answered worse on January 10–14?
 - When did the most people think the economy was getting worse?

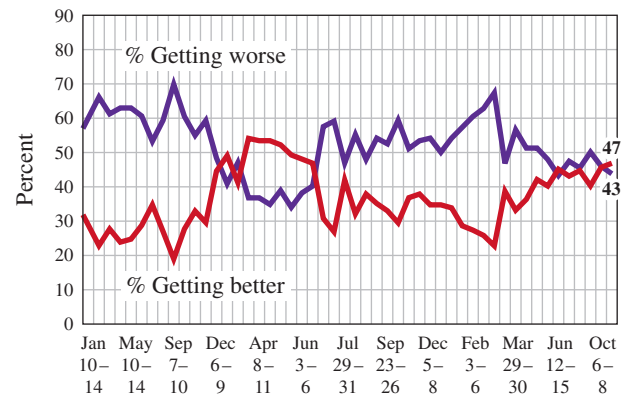

>>> Skill Checker

In Problems 52–56, find:

- | | | |
|---------------------------------|------------------------|-----------------------|
| 52. $\frac{1}{2}$ of 33. | 53. 22% of 500. | 54. 4% of 500. |
| 55. 5% of 500. | 56. 8% of 500. | |

6.3

Circle Graphs (Pie Charts)

▶ Objectives

You should be able to:

- A** > Read and interpret the information in circle graphs.
- B** > Draw circle graphs involving numbers or percents.

▶ To Succeed, Review How To . . .

1. Find the percent of a number. (pp. 318–319, 329)
2. Determine what percent of a whole is a given number. (pp. 318–319, 329)

▶ Getting Started

Can you predict the probability of rainfall using a **circle graph** or **pie chart**? The Bureau of Meteorology does it in Australia. Rainfall predictions can be given using numerical data, in writing or as a circle graph. For example, the chart shown here gives the probability of dry, wet, or normal weather based on the type of year (El Niño, normal, or La Niña).

El Niño Year	Normal Year	La Niña Year
50% dry	33.3% dry	17% dry
17% wet	33.3% wet	50% wet
33% normal	33.3% normal	33% normal

If you know you are having an El Niño year (first column), what can you say about rainfall? The probability that it will be dry is about 50%, wet 17%, and normal 33%. Can you predict what will happen if you are having a La Niña year?

The information can also be summarized using a circle graph. For example, the third circle graph shows the information for a La Niña year. The easiest category to graph is wet because wet represents 50% or half of the circle. The top half of the circle shows dry (17%) and normal (33%). Because 17 is about one-half of 33, the tan region representing the dry weather is about half the size of the normal region. We will learn how to interpret and construct circle graphs in this section.

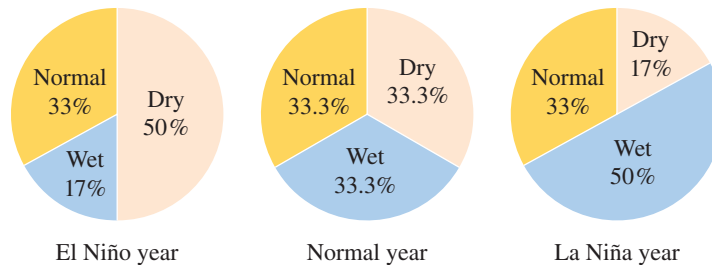

Source: Australian Government Bureau of Meteorology.

A > Reading and Interpreting Circle Graphs

As we have seen in the *Getting Started*, a **circle graph** or **pie chart** is a type of graph that shows what percent of a quantity is used in different categories or the ratio of one category to another. Circle graphs are used when exact quantities are less important than the relative size of the categories. What can these graphs describe? Let us follow the hypothetical routine of a student. You get up and have to decide if you are going to have breakfast.

EXAMPLE 1 Interpreting a circle graph

The circle graph shows how often people eat breakfast.

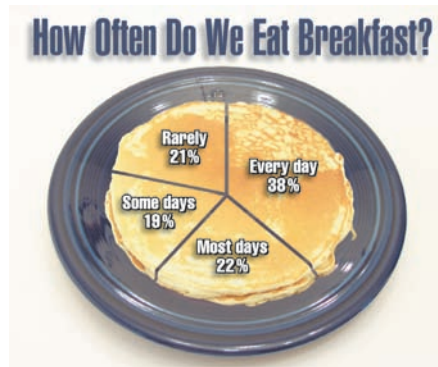

Source: Data from The Quaker Oats Co.

- What percent of the people eat breakfast rarely?
- Which category occupies the largest sector of the graph? What percent of the graph does it occupy?
- If 500 people were surveyed, how many would eat breakfast most days?

SOLUTION 1

- 21% of the people eat breakfast rarely.
- The largest sector is “Every day.” It occupies 38% of the graph.
- 22% of the people eat breakfast most days. If 500 people were surveyed, we would need to find 22% of $500 = 0.22 \cdot 500 = 110$. Thus, 110 of the 500 people surveyed would eat breakfast most days.

PROBLEM 1

Refer to the circle graph and answer the following questions.

- What percent of the people eat breakfast every day?
- Which category occupies the smallest sector of the graph? What percent of the graph does it occupy?
- If 500 people were surveyed, how many would eat breakfast some days?

It is possible that you did not eat any breakfast because you are on a diet. How many people are on a diet? Let us see.

EXAMPLE 2 Interpreting a circle graph

The graph is divided into three categories identified by color. Yes is blue, No is purple, and Not sure is yellow. Answer the questions that follow.

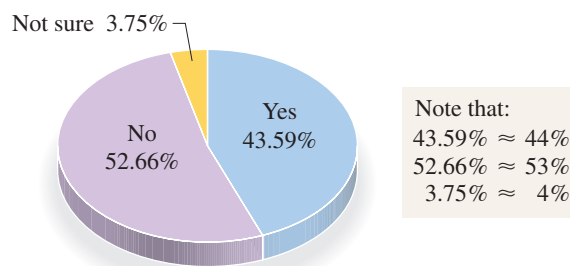
Are You or Anyone in Your Household Currently on a Diet?

Source: Data from Insight Express.

- What percent of the households contain people who are currently on diets?
- Are there more households with people on diets or not on diets?
- If 500 people were surveyed, how many would not be sure?

PROBLEM 2

Refer to the pie chart and answer the following questions to the nearest percent.

- What percent of the households contain people who are currently not on diets?
- What is the difference between the percent of households with people who are not on diets and households with those who are?
- If 500 people were surveyed, how many households would contain people on diets?

(continued)

Answers to PROBLEMS

1. a. 38% b. Some days; 19% c. 95 2. a. 53% b. 9% c. 220

SOLUTION 2

- The blue category, representing households with people who are on diets, occupies 43.59% or about 44% of the total circle. Thus, 44% of the households contain people who are on diets.
- About 44% of the households contain people on diets and about 53% contain people who are not. Thus, there are more households containing people *not* on diets.
- About 4% of the people are not sure. If 500 people were surveyed, this would represent 4% of 500 = $0.04 \cdot 500 = 20$ households.

Now that you have eaten your breakfast, you are ready to go to work. How will you get there? Example 3 will discuss the possibilities.

GREEN MATH

EXAMPLE 3 Interpreting a circle graph

The circle graph shows the percent of people using different forms of transportation to commute to work.

- Which is the most common form of commuting? What percent of the people do it?
- Which is the second most common form of commuting?
- In a group of 500 commuters, how many would you expect to use public transit?

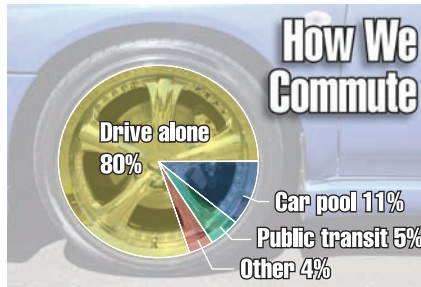

Source: Data from National Public Transportation Survey.

SOLUTION 3

- The most common form of commuting is to drive alone. This is done by 80% of the commuters.
- The second most common form of commuting is carpooling.
- 5% of the commuters use public transit. If there were 500 commuters, we would expect 5% of 500 = $0.05 \cdot 500 = 25$ commuters to use public transit.

PROBLEM 3

Refer to the circle graph and answer the following questions.

- What percent of the commuters carpool?
- What percent of the commuters use other ways of commuting?
- In a group of 500 commuters, how many would you expect to drive alone?

80% of Americans drive alone to work, burning up 34% of the energy used in getting around. In the process, 2.9 gallons of gas each day and 38 hours of time per year are “wasted” when stuck in traffic, costing \$710 per person per year in extra gas and lost productivity.

Source: <http://www.msnbc.msn.com/id/24312866/>.

B > Drawing Circle Graphs

Now that you know how to read and interpret circle graphs dealing with percents, you have to know how to draw them yourself or use a software program to do it for you! The idea behind making circle graphs is similar to the one we used to represent fractions. As you recall from Chapter 2, the fraction $\frac{3}{4}$ can be represented by using a rectangle divided into four equal parts and shading three of these parts as shown:

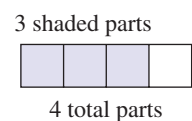
**Answers to PROBLEMS**

3. a. 11% b. 4% c. 400

If instead of a rectangle we were shading a circle to represent the fraction $\frac{3}{4}$, we would divide a circle into four parts and shade three of them as shown:

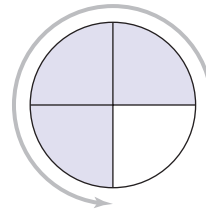

Remember those commuters who drive alone in Example 3? Perhaps you have your own car and you are one of them! We can make a circle graph of the expenses associated with owning a car. To do so, follow these steps.

Step 1. Make a circle.

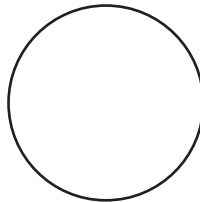

Step 2. Divide it into two equal parts.

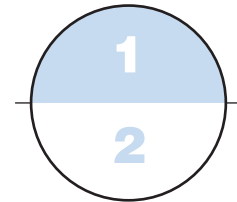

Step 3. Subdivide each of the two parts into five equal parts.

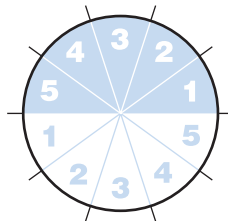

Step 4. Each of the subdivisions represents $\frac{1}{10}$, or 10%.

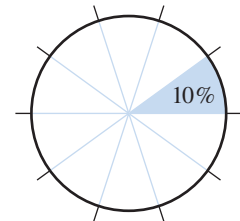

Now, suppose your automobile expense categories last year were as follows:

Payments	\$2500
Gas, oil	1500
Repairs and maintenance	<u>1000</u>
Total	\$5000

To make a circle graph corresponding to this information, we first note that the difference between this problem and the ones we solved before is that the *percents* are not given. However, they can be obtained by comparing each expense to the total as follows:

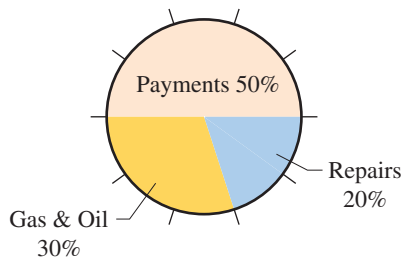

$$\text{Payments} \quad \frac{2500}{5000} = \frac{1}{2} = 50\%$$

$$\text{Gas, oil} \quad \frac{1500}{5000} = \frac{3}{10} = 30\%$$

$$\text{Repairs and maintenance} \quad \frac{1000}{5000} = \frac{1}{5} = 20\%$$

We then make a circle and divide it into 10 equal regions, using 5 for payments, 3 for gas and oil, and 2 for repairs and maintenance as shown in the margin.

EXAMPLE 4 Drawing a circle graph

Make a circle graph to show the following data:

Family Budget (Monthly)

Savings	\$ 300
Housing	500
Clothing	200
Food	800
Other	200
Total	\$2000

SOLUTION 4 We first determine what *percent* of the total each of the items represents.

$$\text{Savings} \quad \frac{300}{2000} = \frac{3}{20} = 15\%$$

$$\text{Housing} \quad \frac{500}{2000} = \frac{1}{4} = 25\%$$

$$\text{Clothing} \quad \frac{200}{2000} = \frac{1}{10} = 10\%$$

$$\text{Food} \quad \frac{800}{2000} = \frac{2}{5} = 40\%$$

$$\text{Other} \quad \frac{200}{2000} = \frac{1}{10} = 10\%$$

We then make a circle, divide it into 10 equal regions, and use $1\frac{1}{2}$ regions for savings (15%), $2\frac{1}{2}$ regions for housing (25%), 1 region for clothing (10%), 4 regions for food (40%), and 1 region for other (10%), as shown in the diagram:

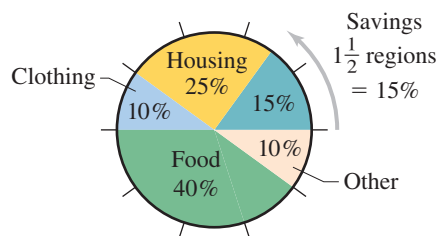
**PROBLEM 4**

Make a circle graph to show the following data:

Family Budget (Monthly)

Savings (S)	\$ 150
Housing (H)	375
Clothing (C)	225
Food (F)	450
Other (O)	300
Total	\$1500

Answers to PROBLEMS

4.

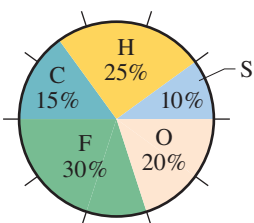

Exercises 6.3



- > Practice Problems
- > Self-Tests
- > Media-rich eBooks
- > e-Professors
- > Videos

A Reading and Interpreting Circle Graphs In Problems 1–10, answer the questions about the circle graphs.

1. *Transportation* Do you have a job? Which method of transportation do you use to get there? The circle graph shows the different modes of transportation used by people going to work in England.

Ways of Traveling to Work

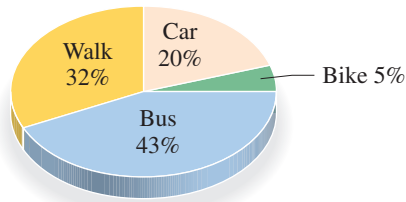

- What is the preferred mode of transportation?
- What is the least-preferred mode of transportation?
- In Dallas-Fort Worth, about 91% of the people drive to work. What is the percent difference of people driving to work between Dallas-Fort Worth and England?

3. *Cheese* The circle graph shows the percents of different types of cheese produced.

Types of Cheese Produced

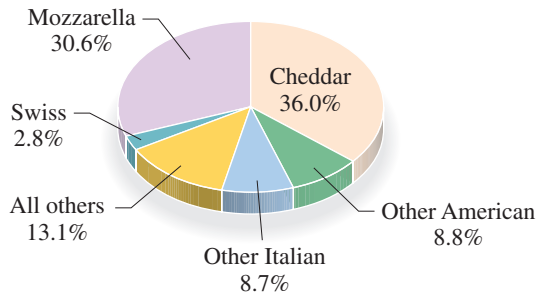

Source: Data from U.S. Department of Agriculture.

- Which type of cheese was produced the most?
- Which type of cheese was produced the least?
- If you assume that the cheese that is produced the most is also the most popular, which is the second most popular cheese?

2. *Daily Routine* The circle graph is divided into 12 equal parts.

One Student's Daily Routine

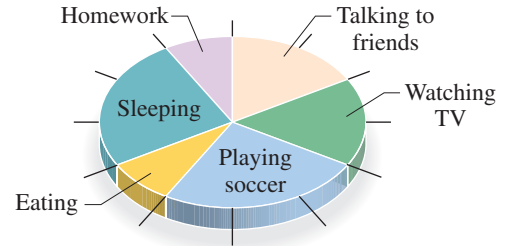

Source: Data from learn.com.uk.

- How many parts (slices) were spent sleeping?
 - How many parts (slices) were spent watching TV?
 - Which activities took the most time?
 - Which activities took the least time?
 - What fraction of the time was spent eating? Remember that the pie has 12 equal parts (slices).
 - What fraction of the time was spent doing homework?
4. *Sea lion* What does a Stellar sea lion eat? The circle graph tells you.



What Does a Stellar Sea Lion Eat?

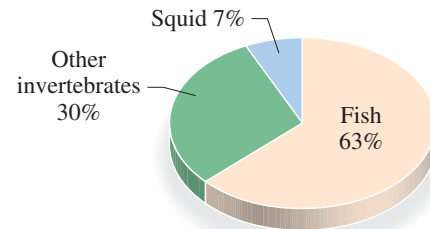

If you are in charge of feeding the Stellar sea lions in the zoo:

- Which food would you stock the most?
- If you buy 100 pounds of sea lion feed, how many pounds should be squid?
- If you buy 200 pounds of Stellar sea lion feed, how many pounds should be squid?

- d. "Other invertebrates" means octopuses, shrimp, and crabs, preferably in the same amounts. If you buy 300 pounds of Steller sea lion feed, how many pounds of crab should it contain?
- f. A female Steller sea lion, on the other hand, weighs about 600 pounds and eats 50 pounds of food each day. How many pounds of squid does she eat each day?
- e. A male Steller sea lion weighs about 2200 pounds and eats about 200 pounds of food each day. How many pounds of fish would he eat?
- g. How many pounds of shrimp does a female Steller sea lion eat every day?

<http://www.seaotter-sealion.org/stellersealion/factsssl.html>.

>>> Applications: Green Math

5. **Water use** The circle graph shows the average indoor water use in Portland, Oregon.

Average Indoor Water Use in Portland, Oregon

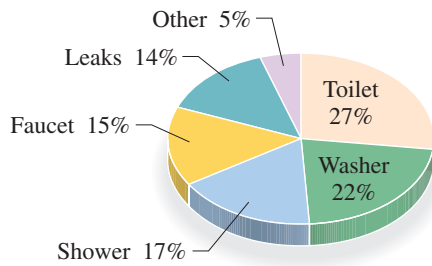

Source: Data from Portland Water Bureau.

- a. Where is the most water used?
 - b. If you use 500 gallons of water, how much would be used for showering?
 - c. What uses more water, the faucet or leaks?
 - d. If "other" uses take 10 gallons of water, how much water would be used by the faucets?
7. **Trash** Have you looked in your trash lately? You have an average trash can if your percents are like those shown.

Have You Looked in Your Trash Lately?

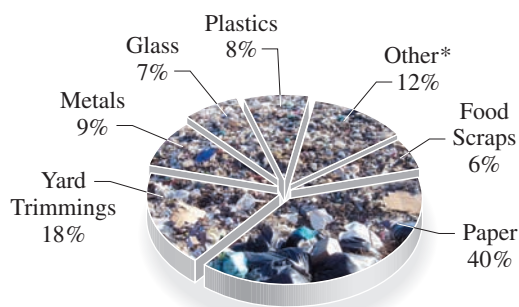

*(e.g., rubber, leather, textiles, wood, miscellaneous inorganic wastes)

Source: Data from U.S. Environmental Protection Agency.

- a. What is the most prevalent item in your trash?
- b. Which is the second most prevalent item in your trash?
- c. Assuming you have 50 pounds of trash, how many pounds of paper would you expect?
- d. How many pounds of yard trimmings would you expect?

Actually, you probably recycle and do not have as much paper!

6. The graph shows the U.S. energy supply sources.

Total = 101.605 Quadrillion Btu

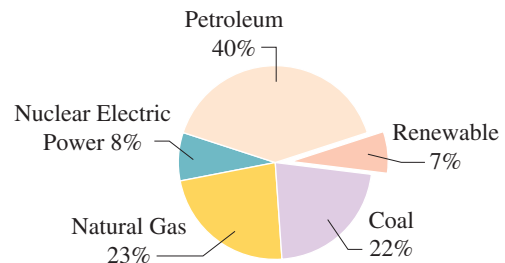

Source: http://tonto.eia.doe.gov/energy_in_brief/renewable_energy.cfm.

- a. Which is the largest source of energy?
 - b. Which is the smallest source of energy?
 - c. What percent of the energy is coal?
 - d. What percent of the energy is natural gas?
 - e. What percent is renewable (Energy generated from natural resources, see Exercise 8)?
8. The graph shows the percent distribution of **renewable** energy. (Biomass means trees, grass crops, and other living plant materials like the rain forest.)

Renewable Energy Sources

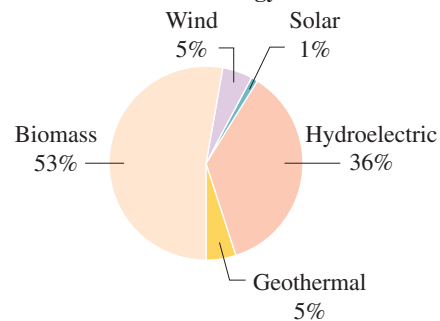

- a. Which is the largest renewable energy source?
- b. Which is the smallest renewable energy source?
- c. What percent of the renewable energy is geothermal?
- d. What percent of the renewable energy is wind?

9. *Energy* The circle graph shows the breakdown of how the world produces its energy.

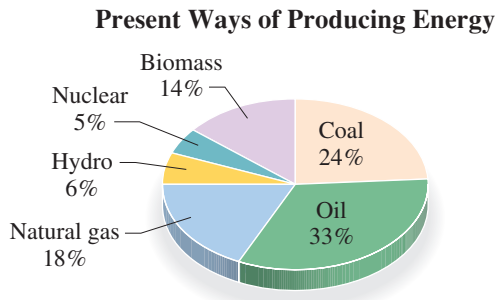

Source: Data from University of Michigan.

- Which energy source produces the most energy?
- Which energy source produces the least energy?
- Fossil fuels (coal, oil, and natural gas) emit greenhouse gases when burned. Which of these three fossil fuels produces the least energy?

Expenses The following circle graph will be used in Problems 11–13.

- Which is the greatest expense?
- Which is the second-largest expense?
- Which is the smallest expense?

Expenses at a Community College

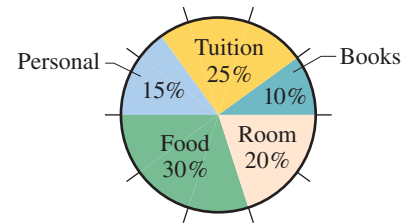

B Drawing Circle Graphs In Problems 14–24 make a circle graph for the given data.

14.

Automobile Expenses	
Payments	\$3000
Gas, oil	1000
Repairs	500
Tires	200
Insurance	300
Total	\$5000

Automobile Expenses

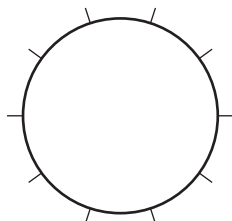

15.

Family Budget (Monthly)	
Savings	\$ 150
Housing	250
Clothing	100
Food	400
Other	100
Total	\$1000

Family Budget (Monthly)

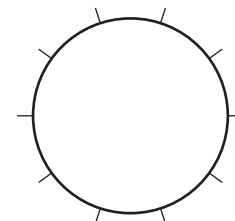

10. *Government* Refer to the circle graph showing where the federal government dollar comes from.

Where the Federal Government Dollar Comes From

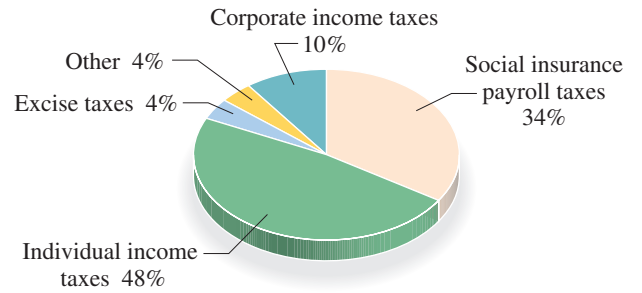

Source: Data from Economic Report of the President.

- From what source does the federal government get the most money? What percent?
- What is the second-largest source of money for the federal government? What percent?
- If the total amount generated (coming in) amounts to \$1700 billion, how much is generated by corporate income taxes?

16. School Expenses (per Semester)

Room	\$ 600
Food	1050
Tuition	690
Travel	450
Books	210

School Expenses

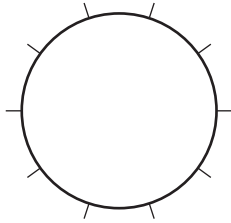

17. Chores Done by Husbands (Weekly)

Housework	36 minutes
Kitchen work	12 minutes
Family care	24 minutes
Shopping	24 minutes

Chores Done by Husbands

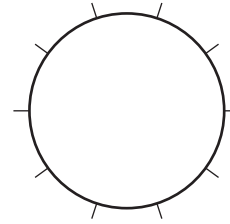

18. Vacations According to a survey of 800 persons made by the U.S. Travel Data Center, the most likely places to spend our summer vacations are:

City	248
Ocean	208
Small town	176
Mountains	80
Lakes	40
National parks	48

Places to Spend Summer Vacation

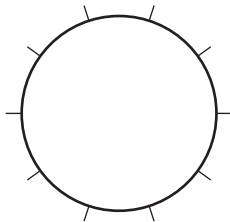

19. Cars According to a Roper Report, 9 out of 10 people in the United States belong to a family in which one member owns a car. Here is what they own:

Midsized	630
Full-size	522
Compact	378
Pickup	144
Other	<u>126</u>
Total	1800

Type of Car Owned by Family with a Car

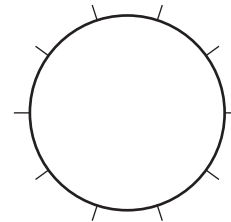

20. Food In a recent survey of 2000 people made by the Snackfood Association, the favorite flavors of potato chips were as follows:

Regular salted	1320
Barbecue	248
Sour cream and onion	206
Cheddar cheese	78
Regular unsalted	36
Other	112

Favorite Flavors of Potato Chips

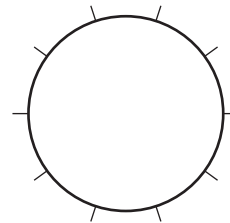

- 21. Internet** How do you use the Internet? A survey of 1062 students conducted by BSA-Ipsos indicated that the number of students using the Internet for personal, school, and work was as follows:

Personal use:	670
School use:	360
Work use:	32

Round to the nearest percent.

Student Internet Use

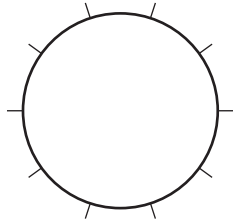

Source: <http://www.definetheline.com>.

- 22. Internet** How do your professors use the Internet? The number of academics using the Internet for personal, school, and other uses according to a survey of 200 academics conducted by BSA-Ipsos was as follows:

Personal use:	22
Other use:	0
Work use:	178

Round to the nearest percent.

Academics Internet Use

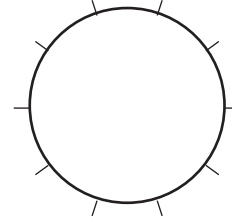

Source: <http://www.definetheline.com>.

- 23. Software** Should you be punished for using unlicensed or pirated software? The number of academics calling for the indicated punishment in a BSA-Ipsos survey of 200 academics is as shown:

No computing resources:	100
Academic probation:	30
No penalty:	28
Fined:	24
Suspended:	10
Not sure:	8

Round to the nearest percent.

Punishment for Using Unlicensed or Pirated Software

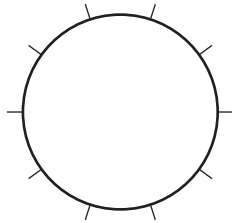

Source: <http://www.definetheline.com>.

- 24. Software** How do students feel about using unlicensed or pirated software? The number of students calling for the indicated punishment in the BSA-Ipsos survey of 1062 students is as shown:

No penalty:	350
No computer resources:	319
Academic probation:	127
Suspended:	32
Not sure:	234

Round to the nearest percent.

Punishment for Using Unlicensed or Pirated Software

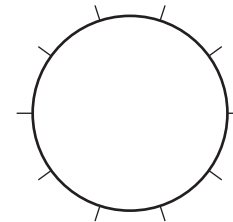

Source: <http://www.definetheline.com>.

>>> Applications: Green Math

Water Pollution Some of the circle graphs we have studied have been divided into 10 equal regions, each representing 10%. There is another way of drawing these graphs. As you may know, a circle has 360 degrees (written 360°). Now, suppose you wish to make a circle graph for the following data:

Sources of Water Pollution	
Industrial	60%
Urban sewage	25%
Agriculture	15%

How many degrees will correspond to each category?

For industrial pollution we need	60% of 360°
or	$0.60 \times 360^\circ = 216^\circ$
For urban sewage we need	25% of 360°
or	$0.25 \times 360^\circ = 90^\circ$
For agriculture we have	15% of 360°
or	$0.15 \times 360^\circ = 54^\circ$

You can then use an instrument called a **protractor** to measure these degrees, mark the corresponding regions in the circle, and finish the graph.

Now, the sources of air pollution are as shown in the table.

Transportation	40%
Fuel combustion	20%
Industry	15%
Other	25%

Use your knowledge to find the number of degrees corresponding to each of the following categories.

- | | |
|---------------------------|----------------------------|
| 25. Transportation | 26. Fuel combustion |
| 27. Industry | 28. Other |

>>> Write On

- 29.** Write a description of a circle graph (pie chart) in your own words. **30.** What is the relation between circle graphs and percents?

>>> Concept Checker

Fill in the blank(s) with the correct word(s), phrase, or mathematical statement.

- 31.** A _____ **graph** is a type of graph that shows what percent of a quantity is used in different categories.
- 32.** A **circle graph** can show the _____ of one **category** to another.

bar
line
ratio

circle
relationship

>>> Mastery Test

The graph will be used in Problems 33–35.

The average American worker stays late at work three to five days a week. The graph shows the percent of workers who say they stay late at work the number of hours in the graph.

33. What percent of the workers stay late for exactly one hour?
34. What percent of the workers stay late for exactly two hours?
35. If your company has 500 employees, how many would you expect to say they worked late for three hours?



Source: Data from Management Recruiters International.

36. When 1700 adults age 20 and older were asked how often they barbecued, the results were as follows:

- 170 said never.
- 510 said two to three times a month.
- 425 said less than once a month.
- 340 said once a month.
- 255 said once a week or more.

Make a circle graph for the data.

How Often Do You Barbecue?

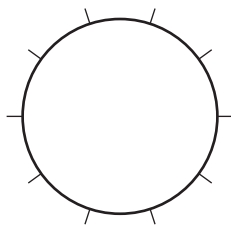

>>> Skill Checker

In Problems 37–40, find:

37. $\frac{2.41 + 2.51 + 2.61}{3}$

39. $\frac{1.41 + 1.45 + 1.51 + 1.63}{4}$

38. $\frac{208 + 179 + 150}{3}$

40. $\frac{157 + 116 + 104 + 99 + 89}{5}$

6.4

Mean, Median, and Mode

▶ Objectives

You should be able to:

- A > Find the mean of a set of numbers.
- B > Find the median of a set of numbers.
- C > Find the mode of a set of numbers.
- D > Solve applications involving the mean, median, and mode.

▶ To Succeed, Review How To . . .

1. Add, subtract, multiply, and divide decimals. (pp. 212–217, 222–226)
2. Round numbers. (pp. 226–227)

▶ Getting Started

What is the *average* price of gas in your area? At the Amoco station, the **average** price is the sum of the three prices divided by 3, that is,

$$\frac{\$2.51 + \$2.64 + \$2.74}{3} = \frac{\$7.89}{3} = \$2.63$$



Now, what is the number in the middle (**median**) for the Amoco gas? It is \$2.64. What about the median for the four prices in the Hess gas? Is there one? Next, is there a price that occurs more than the others do? If you look at all the gas prices shown, the number 2.51 occurs twice; it is the **mode** for the prices. We make these ideas precise next.

A > Finding the Mean

The most common average for a set of n numbers is the *mean* or *average*. The **mean** is a statistic (a number that describes a set of data) that measures *central tendency*, a sort of *center* for a set of numbers. Here is the definition.

MEAN

The mean (average) of a set of n numbers is the sum of the numbers divided by the number n of elements in the set.

Thus, the average price of Hess non-diesel gas (regular, plus, premium) is

$$\frac{\$2.41 + \$2.51 + \$2.61}{3} = \frac{\$7.53}{3} = \$2.51$$

GREEN MATH

EXAMPLE 1 Mean global warming

Global warming can burn the rain forest, kill plants, and melt the polar ice. That will cause flooding in New York, India, California, and many other places. But is Earth's average (mean) temperature rising? The table shows the global temperature in degrees Fahrenheit for two 3-year periods 100 years apart. What is the average (mean) temperature for the years 1905 through 1907?

SOLUTION 1 To find the mean of the three numbers, we add the numbers and divide by 3, obtaining:

$$\frac{56.75 + 56.93 + 56.48}{3} = \frac{170.16}{3} = 56.72$$

Thus, the average temperature for the three years is 56.72. Compare the answer to that of Problem 1. Is the average temperature rising?

PROBLEM 1

What is the average (mean) temperature for the years 2005 through 2007? Answer to the nearest hundredth (two decimal digits).

1905	56.75	2005	58.56
1906	56.93	2006	58.38
1907	56.48	2007	58.51

Source: Earth Policy Institute.

EXAMPLE 2 Calculating the mean

Have you been drinking your milk? How many calories did you consume? If we allow you to count chocolate milk, the chart shows the number of calories per cup in four types of milk. Find the average (mean) number of calories per cup.

How Milk Measures up in Calories

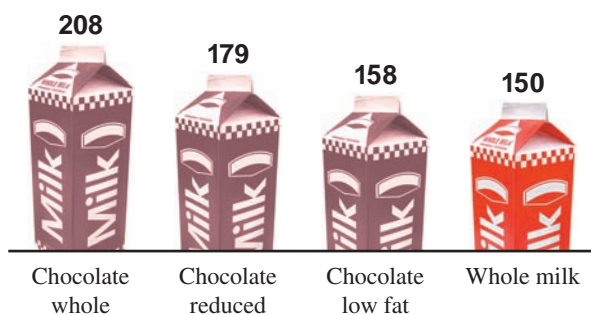

Source: Data from USA TODAY.

SOLUTION 2 There are four types of milk and they contain 208, 179, 158, and 150 calories per cup. Thus, the mean average number of calories is

$$\frac{208 + 179 + 158 + 150}{4} = \frac{695}{4} = 173.75 \approx 174 \text{ calories}$$

Remember that the symbol \approx means “approximately equal.” We rounded the answer to the nearest calorie, obtaining 174.

PROBLEM 2

Here is the caloric content of four types of hamburgers:

Generic large (no mayo)	511
McDonald's Big Mac	540
Burger King Supreme	550
Whataburger	620

Find the average (mean) number of calories in these hamburgers.

One of the most important averages at this time is your grade point average (GPA). Calculating your grade point average is an example of a **weighted mean**. First, each class you take carries a number of credit hours, and each grade you make is assigned a weight as follows: A: 4 points; B: 3 points; C: 2 points; D: 1 point; F: 0 points. You earn

Answers to PROBLEMS

- 58.48
- $555.25 \approx 555$ calories

points by multiplying the number of credit hours in a class by the weight of your grade. For example, if you make an A (4 points) in a 3-hour class, you get $4 \times 3 = 12$ points. For a C (2 points) in a 4-hour class, you get $2 \times 4 = 8$ points. To find your GPA you divide the number of points earned by the number of credit hours you are taking. Here is an example from Oklahoma State University.

EXAMPLE 3 Calculating a weighted mean

Suppose you are taking five courses with the credit hours, grades earned, and points shown. What is your GPA?

Course	Credit Hours	Grade Earned	Points Earned
A&S 1111	1	A (4)	$1 \times 4 = 4$
ENGL 1113	3	A (4)	$3 \times 4 = 12$
PSYC 1113	3	B (3)	$3 \times 3 = 9$
HIST 1103	3	B (3)	$3 \times 3 = 9$
CHEM 1314	4	C (2)	$4 \times 2 = 8$
	14 credit hours		42 points earned

SOLUTION 3 As you can see from the table, the number of credit hours in each course is in the second column (14 total), the grade earned and the corresponding points in the third column [A(4), A(4), B(3), B(3), and C(2)], and the points earned, the product of the numbers in columns 2 and 3, in the last column (42 total).

$$\text{Your GPA is the: } \frac{\text{Points earned}}{\text{Credit hours}} = \frac{42}{14} = 3.$$

Note that in general, the GPA may not be a whole number.

PROBLEM 3

Find the GPA for a student at the University of Texas with the courses, grades, and credit hours shown. Round the answer to two decimal places.

Course	Grade	Hours	Grade Points
English	A	3 sem. hours \times 4 pts. = 12	
Mathematics	D	3 sem. hours \times 1 pt. = 3	
History	A	3 sem. hours \times 4 pts. = 12	
Chemistry	B	4 sem. hours \times 3 pts. = 12	
Kinesiology	B	1 sem. hour \times 3 pts. = 3	

Source: Data from University of Texas at Brownsville.

B > Finding the Median

As we mentioned in the *Getting Started* section, there is another type of “average” or measure of central tendency: the median.

Here is the official definition.

MEDIAN

The median of a set of numbers is the middle number when the numbers are arranged in ascending (or descending) order and there is an **odd** number of items. If there is an **even** number of items, the median is the average of the two **middle** numbers.

For the Amoco gas, the middle price is easy to find: 2.64. If we use the first three prices in the Hess sign, the middle price is 2.51. But suppose you want to find the middle price for the four prices: 2.41, 2.51, 2.61, and 2.45. Two things to notice:

1. The prices are not in order.
2. The number of prices is even, so there is no middle price.

Answers to PROBLEMS

3. 3.00



We can fix both problems!

1. Write the prices in order (ascending or descending).
2. To find the middle, find the average of the two middle prices.

Like this:

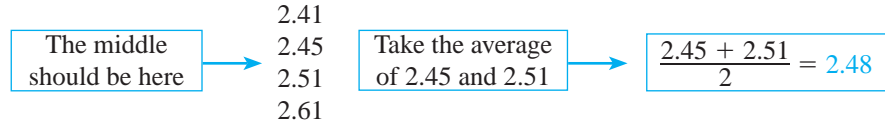

Thus, the “middle number” of 2.41, 2.45, 2.51 and 2.61, the *median*, is 2.48.

EXAMPLE 4 Calculating the median

How much do you spend on health care? The amounts spent the last four years for persons under 25 are as shown. What is the median amount of money spent on health care for persons under 25?

1	445
2	551
3	504
4	530

Source: Data from Bureau of Labor Statistics.

SOLUTION 4 Note that the numbers are not in order, so we rewrite them in ascending order:

445 504 530 551

$\frac{504 + 530}{2} = 517$

Since we have an *even* number of items (4), take the average of the two middle numbers. The result is the median.

The median is \$517.

PROBLEM 4

The amount spent the last four years for persons between 25 and 34 are as shown. What is the median amount of money spent on health care by persons between 25 and 34?

1	1185
2	1170
3	1256
4	1286

C > Finding the Mode

We mentioned one more measure of central tendency, the number that occurs the most frequently, called the **mode**. If we look at the prices at the Amoco station, no price is more prevalent than any of the other prices. The same is true of the gas prices at Hess. Now, let us look at the prices at *both* gas stations:

$$2.51, 2.64, 2.74, 2.41, 2.51, 2.61, 2.45$$

There is a number that occurs twice: 2.51. This number is called the mode. Here is the definition:

MODE

The mode of a set of numbers is the number in the set that occurs most often.

1. If there is **no** number that occurs most often, the set has no mode.
2. If several numbers occur an equal number of times, the data set will have several modes.

Answers to PROBLEMS

4. \$1220.50

EXAMPLE 5 Finding the mode

Find the mode of 3, 8, 7, 5, 8.

SOLUTION 5 The number that occurs most often (twice) is 8, so 8 is the mode.

PROBLEM 5

Find the mode of:

7 4 5 4 3

Note that a set of numbers can only have one mean and one median but could have *more than one* mode. For example, the set

9 3 4 9 3 7

has two modes, 9 and 3. On the other hand, the set

9 3 4 5 2 7

has no mode.

D > Applications Involving Mean, Median, and Mode

We have introduced three measures of central tendency. The following shows how they compare:

1. The Mean

The most commonly used of the three measures.

Good: A set of data always has a unique mean, which takes account of each item of the data.

Bad: Finding the mean takes the most calculation of the three measures.

Bad: Sensitivity to extreme values. For instance, the mean of the data 2, 4, 6, and 8 is $\frac{20}{4} = 5$, but the mean of 2, 4, 6, and 48 (instead of 8) is $\frac{60}{4} = 15$, a shift of 10 units toward the extreme value of 48.

2. The Median

Good: The median always exists and is unique.

Good: Requires very little computation and is not sensitive to extreme values.

Bad: To find the median, the data must be arranged in order of magnitude, and this may not be practical for large sets of data.

Bad: Failure to take account of each item of data. Hence, in many statistical problems, the median is not a reliable measure.

3. The Mode

Good: Requires no calculation.

Good: The mode may be most useful. For example, suppose a shoe manufacturer surveys 100 women to see which of three styles, A, B, or C, each one prefers. Style A is selected by 30 women, style B by 50, and style C by 20. The mode is 50, and there is not much doubt about which style the manufacturer will feature.

Bad: The mode may not exist, as in the case of the data 2, 4, 6, and 8 (there is no mode).

EXAMPLE 6 Finding the mean, median, and mode

The payrolls of the 10 best-paid teams in Major League Baseball, approximated to the nearest million, are in the last column of the table.

- Find the mean of the salaries.
- Find the median of the salaries.
- Find the mode of the salaries.
- Why is the mean higher than the median?

No.	Team	Payroll
1.	New York Yankees	\$201,449,289 \approx 201 million
2.	New York Mets	\$135,773,988 \approx 136 million
3.	Chicago Cubs	\$135,050,000 \approx 135 million
4.	Boston Red Sox	\$122,696,000 \approx 123 million
5.	Detroit Tigers	\$115,085,145 \approx 115 million
6.	Los Angeles Angels	\$113,709,000 \approx 114 million
7.	Philadelphia Phillies	\$113,004,048 \approx 113 million
8.	Houston Astros	\$102,996,415 \approx 103 million
9.	Los Angeles Dodgers	\$100,458,101 \approx 100 million
10.	Seattle Mariners	\$98,904,167 \approx 99 million

Source: <http://www.cbssports.com/mlb/salaries>.

SOLUTION 6

- a. The mean of the 10 salaries is

$$\frac{201 + 136 + 135 + 123 + 115 + 114 + 113 + 103 + 100 + 99}{10} = \frac{1239}{10} \approx 124 \text{ million}$$

- b. The numbers are

201	136	135	123	115	↑	114	113	103	100	99
5 numbers						5 numbers				

$$\text{Median: } \frac{115 + 114}{2} = \frac{229}{2} = 114.5$$

- There is no mode.
- The mean (124) is higher than the median (114.5) because of the high salaries for the New York Yankees. If the New York Yankees' \$201 million is excluded from the calculations, the mean is about \$115 million, an amount closer to the median.

PROBLEM 6

Here are the 2006/2007 salaries for six members of the Los Angeles Lakers basketball team, approximated to the nearest million.

Player	Salary
Kobe Bryant	\$21,262,500 \approx 21 million
Pau Gasol	\$15,080,312 \approx 15 million
Lamar Odom	\$11,400,000 \approx 11 million
Derek Fisher	\$4,698,000 \approx 5 million
Sasha Vujacic	\$4,524,887 \approx 5 million

Source: http://hoopshype.com/salaries/la_lakers.htm.

- Find the mean of the approximated salaries.
- Find the median of the approximated salaries.
- Find the mode of the salaries.
- Why is the mean higher than the median?



Calculator Corner

If you have a calculator with $\Sigma+$ (read "sigma plus") and \bar{x} (x bar) keys, you are in luck. The calculation for the mean is automatically done for you. First, place the calculator in the statistics mode (press **MODE** **STAT** or **ADD** **STAT**).

To find the mean of the numbers in Example 2, press **2** **0** **8** $\Sigma+$ **1** **7** **9** $\Sigma+$ **1** **5** **8** $\Sigma+$ **1** **5** **0** $\Sigma+$ and finally \bar{x} . The answer 173.75 will automatically appear. If you do not have the $\Sigma+$ and \bar{x} keys, use parentheses and enter **(** **2** **0** **8** **+** **1** **7** **9** **+** **1** **5** **8** **+** **1** **5** **0** **)** **÷** **4** **ENTER** and then you will get the 173.75.

Answers to PROBLEMS

6. a. 11.4 million b. 11 million c. 5 million d. Because Kobe Bryant pulls up the average salary.



> Practice Problems > Self-Tests
> Media-rich eBooks > e-Professors > Videos

> Exercises 6.4

< **A** > **Finding the Mean** In Problems 1–4, find the mean (average) of the numbers.

1. 1, 5, 9, 13, 17 2. 1, 3, 9, 27, 81, 243 3. 1, 4, 9, 16, 25, 36 4. 1, 8, 27, 64, 125

< **B** > **Finding the Median** In Problems 5–8, find the median of the numbers.

5. 1, 5, 9, 13, 17 6. 1, 3, 9, 27, 81, 243 7. 1, 9, 36, 4, 25, 16 8. 1, 27, 8, 125, 64

< **C** > **Finding the Mode** In Problems 9–12, find the mode(s) if there is one.

9. 5, 89, 52, 5, 52, 98 10. 29, 25, 22, 25, 52, 8 11. 2, 7, 11, 8, 11, 8, 11 12. 2, 8, 8, 8, 1, 2, 2, 2, 2

< **D** > **Applications Involving Mean, Median, and Mode**

Gas prices The following table will be used in Problems 13–14. Round answers to the nearest cent.

International Gasoline Prices

Most Expensive		Least Expensive	
Location	Price per Gallon	Location	Price per Gallon
Hong Kong	\$5.34	Caracas, Venezuela	\$0.28
London, England	\$4.55	Jakarta, Indonesia	\$0.74
Paris, France	\$4.41	Cairo, Egypt	\$0.75
Amsterdam, Neth	\$4.38	Kuwait City, Kuwait	\$0.77
Seoul, S. Korea	\$4.35	Manama, Bahrain	\$0.82

Source: Runzheimer International.

13. **a.** Find the mean, median, and mode of the five most expensive prices.
b. Are the mean, median, and mode close?
c. Which of the three do you think is most representative of the prices?
d. Delete Hong Kong and answer part **c** again.
14. **a.** Find the mean, median, and mode of the five least expensive prices.
b. Are the mean, median, and mode close?
c. Which of the three do you think is most representative of the prices?
d. Delete Caracas and answer part **c** again.
15. *GPA* Find the GPA for a student taking 13 hours at Mary Washington College. Weight of grade: A = 4 points, B = 3 points, C = 2 points, D = 1 point, F = 0 points, ZC = 0 points. Round answers to two decimal places.
16. *GPA* Find the GPA (to the nearest hundredth) for a student taking 13 hours at Montgomery College. Weight of grade: A = 4 points, B = 3 points, C = 2 points, D = 1 point, F = 0 points. Round answers to two decimal places.

Course	Grade	Credits Attempted	Credits Earned
MATH0111	A	3.0	3.0
ENGL0101	B	3.0	3.0
PSYC0101	D	3.0	3.0
BIOLO121	F	4.0	0.0
BIOLO121LB	ZC	0.0	0.0
Totals:		13.0	9.0

Source: Data from Mary Washington College.

Course	Credit Hrs (CH)	Grade
PY102	3	A
SO101	3	C
BI101	4	B
PE129	1	A
HE107	2	B
	<u>13</u>	

Source: Data from Montgomery College.

17. Average annual salary The table shows the average annual salary for five consecutive years for a person with an associate degree.

- a. Find the mean, median, and mode of the person's salary for the five years.

1	39,468
2	39,276
3	40,827
4	46,778
5	49,733

- b. Which is the most representative of the person's salary: the mean, the median, or the mode?

18. Average annual salary The table shows the average annual salary for five consecutive years for a person with less than a high school diploma.

- a. Find the mean, median, and mode of the person's salary for the five years. (Compare with the person in Problem 17!)

1	20,484
2	19,935
3	21,611
4	22,679
5	23,845

- b. Which is the most representative of the person's salary: the mean, the median, or the mode?

Source: Bureau of Labor Statistics.

19. Major League Baseball (MLB) salaries The table shows the 2009 salaries for the 10 best-paid MLB baseball players.

- a. Round the salaries to the nearest million.
 b. Find the mean, median, and mode of the rounded salaries.
 c. Which is the most representative of the salaries: the mean, the median, or the mode?

Top 10 MLB Players

No.	Position	Player	Team	Salary
1.	3B	Alex Rodriguez	Yankees	\$33,000,000
2.	OF	Manny Ramirez	Los Angeles	\$23,854,494
3.	SS	Derek Jeter	Yankees	\$21,600,000
4.	1B	Mark Teixeira	Yankees	\$20,625,000
5.	CF	Carlos Beltran	Mets	\$19,243,682
6.	LF	Carlos Lee	Astros	\$19,000,000
7.	RF	Magglio Ordonez	Detroit	\$18,971,596
8.	P	Johan Santana	Mets	\$18,876,139
9.	P	Carlos Zambrano	Cubs	\$18,750,000
10.	P	Barry Zito	San Francisco	\$18,500,000

Source: <http://www.cbssports.com/mlb/salaries/top50>.

20. Annual salaries Who makes more money, the baseball players or university presidents? The table shows the 10 best-paid presidents at public universities in the United States.

- a. Round the salaries to the nearest thousand dollars.
 b. Find the mean, median, and mode of the rounded salaries.
 c. Which is the most representative of the salaries: the mean, the median, or the mode?
 d. What is the difference between the mean and median of baseball players (Problem 19) and college presidents?

Shirley Ann Jackson, Rensselaer Polytechnic Institute	\$891,400
Gordon Gee, Vanderbilt University	\$852,023
Judith Rodin, University of Pennsylvania	\$845,474
Arnold J. Levine, Rockefeller University	\$844,600
William R. Brody, Johns Hopkins University	\$772,276
Michael R. Ferrari, Texas Christian University	\$667,901
Steven B. Sample, University of Southern California	\$656,420
Jon Westling, Boston University	\$656,098
Richard C. Levin, Yale University	\$654,452
Constantine N. Papadakis, Drexel University	\$650,886

Source: Data from The Chronicle of Higher Education.

21. Major League salaries The table shows the salaries for the 5 most overpaid players in Major League Baseball according to Foxsports.

Source: <http://msn.foxsports.com>.

- a. Round the salaries to the nearest million.
- b. Find the mean, median, and mode of the rounded salaries. Round answers to one decimal place.
- c. Which is the most representative of the salaries: the mean, the median, or the mode?

Player	Position	Team	Salary
Brad Lidge	Pitcher	Phillies	\$11.5 million
David Ortiz	DH	Red Sox	\$12.5 million
Carlos Silva	Pitcher	Mariners	\$11 million
Oliver Perez	Pitcher	Mets	\$12 million
Brian Giles	Right Fielder	Padres	\$9 million

Source: <http://tinyurl.com/16bruj>.

22. Major League salaries What is the salary difference between the overpaid and the underpaid players in Major League Baseball? The table shows the salaries for the 5 most underpaid players in Major League Baseball according to Foxsports.

- a. Find the mean, median, and mode of the salaries.
- b. Which is the most representative of the salaries: the mean, the median, or the mode?
- c. What is the difference between the mean and median of overpaid baseball players (Problem 21) and underpaid baseball players?

Player	Position	Team	Salary
John Baker	Catcher	Marlins	\$400,000
Joey Votto	1st Base	Cincinnati	\$437,500
Dustin Pedroia	2nd Base	Red Sox	\$1,750,000
Ryan Theriot	Short Stop	Chicago Cubs	\$500,000
Evan Longoria	3rd Base	Rays	\$550,000

Source: <http://www.cbssports.com/mcc/messages/chrono/15300232>.

23. Annual salaries What college degree will earn you the most money? At the moment, engineering majors are seeing the most cash. The average salary in four engineering fields is as shown. Find the mean and median for the four salaries.

Source: <http://www.shreveporttimes.com>.

Chemical engineering	\$55,900
Electrical engineering	\$52,899
Mechanical engineering	\$50,672
Civil engineering	\$44,999

24. Annual salaries Another field bringing increased salaries is accounting. Of course, it depends where the job is. K-Force, a staffing firm based in Tampa, Florida, reports the following entry-level salaries for general-accounting staff members in four cities.

- a. Find the mean and median for the salaries in the four cities.
- b. According to the *College Journal*, “Recent accounting graduates received an average annual starting salary of \$46,188.” Is this closer to the mean or to the median in part a?

Boston	\$41,600
New York	\$51,800
Chicago	\$48,700
San Francisco	\$53,800

Source: <http://www.collegejournal.com>.

>>> Applications: Green Math

25. *Global Temperatures* The table shows the approximate global temperature in degrees Celsius for five different decades. Find, to two decimal places:

1960–1969	13.96
1970–1979	14.02
1980–1989	14.26
1990–1999	14.40
2000–2007	14.64

- The average (mean) temperature for the five decades.
- The median temperature for the five decades.
- The mode temperature for the five decades.

Source: <http://tinyurl.com/ydujn85>.

>>> Using Your Knowledge

Misuses of Statistics We have just studied three measures of central tendency: the mean, the median, and the mode. All these measures are frequently called **averages**. Suppose that the chart shows the salaries at Scrooge Manufacturing Company.

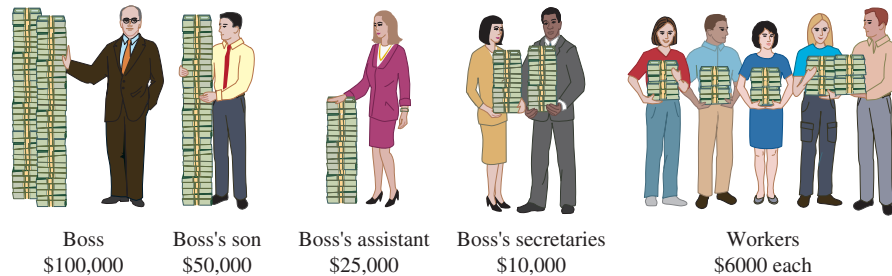

- Scrooge claims that the workers should not unionize; after all, he says, the *average* salary is \$22,500. Can you discover what average this is?
- B. Crooked, the politician, wants both union and management support. He says that the workers are about *average* as far as salary is concerned. The company's *average* salary is \$8000. Can you discover what average B. Crooked has in mind?
- Manny Chevitz, the union leader, claims that Scrooge Manufacturing really needs a union. Just look at their salaries! A meager \$6000 on the *average*. Can you discover what average he means?

>>> Write On

- Write in your own words what is meant by the median of a set of scores. Is the median a good measure of a set of scores? Give examples.
- Write in your own words what is meant by the mode of a set of scores. Is the mode a good measure of a set of scores? Is it possible to have more than one mode in a set of scores? Is it possible that there is no mode for a set of scores? Give examples.

>>> Concept Checker

Fill in the blank(s) with the correct word(s), phrase, or mathematical statement.

31. The _____ of a set of n numbers is the **sum** of the numbers **divided by** the number n of elements in the set. **smallest**
32. For an _____ number of items, the _____ of a set of numbers is the **middle number** when the numbers are arranged in order. **one**
33. For an _____ number of items, the _____ of a set of numbers is the _____ of the **two middle numbers**. **mean**
34. The _____ of a set of numbers is the **number that occurs the most often** in the set. **even**
35. When no number occurs most often in a set of numbers, the set has no _____. **odd**
36. A set of numbers can only have _____ **mean** and _____ **median**, but it could have **more than one** _____. **mode**
- median**
- average**
- largest**

>>> Mastery Test

The table shows the number and type of spam (unsolicited “junk” e-mail sent to large numbers of people to promote products or services) received by the same 200 persons in July and August.

37. Find the mean number of spam e-mails received in July.
38. Find the median number of spam e-mails received in July.
39. Find the mode (if it exists) of the number of spam e-mails received in July.
40. Name the categories in which the number of spam e-mails received did not change from July to August.
41. Which category increased the most from July to August?

Type of Spam	July	August
Internet	14	22
Other	28	32
Scams	18	20
Products	40	40
Spiritual	2	2
Financial	30	28
Leisure	16	14
Adult	28	24
Health	24	18

Source: Data from Brightmail Probe Network.

42. Find the GPA of a student taking 13 credit hours at Raritan Valley Community College and earning the grades and points shown. Weight of grade: A = 4 points, B = 3 points, C = 2 points, D = 1 point, F = 0 points. Answer to two decimal places.

Course	Credits	Grade
History	3	W (-)
English	3	A (4)
Psychology	3	C (2)
French	4	D (1)

Note: W means the student withdrew. No credits or points counted.

>>> Skill Checker

In Problems 43–47, Multiply:

43. $60 \cdot \frac{1}{12}$

44. $11 \cdot \frac{1}{12}$

45. $10,560 \cdot \frac{1}{5280}$

46. $7.75 \cdot 12$

47. $8.75 \cdot 12$

Collaborative Learning

Form two groups. One group will investigate **race** discrimination complaints, and the other will investigate **sex** discrimination complaints, as shown in the following tables.

Race-Based Charges

	FY 1998	FY 1999	FY 2000	FY 2001	FY 2002
Complaints	28,820	28,819	28,945	28,912	29,910
Resolutions	35,716	35,094	33,188	32,077	33,199
Monetary benefits (in millions)	\$32.2	\$53.2	\$61.7	\$86.5	\$81.1

Sex-Based Charges

	FY 1998	FY 1999	FY 2000	FY 2001	FY 2002
Complaints	24,454	23,907	25,194	25,140	25,536
Resolutions	31,818	30,643	29,631	28,602	29,088
Monetary benefits (in millions)	\$58.7	\$81.7	\$109.0	\$94.4	\$94.7

Source: Data from U.S. Equal Opportunity Commission.

Answer the questions.

1. What was the average number of complaints for racial discrimination and for sex discrimination from 1998 to 2002?
2. What was the average number of resolutions for racial discrimination and for sex discrimination from 1998 to 2002?
3. What were the average monetary benefits for 1998 to 2002?

Discussion Which average monetary benefit per resolved case was greater, race or sex discrimination? Why? ▣

Research Questions

1. Go to the library, look through newspapers and magazines, and find some examples of bar and circle graphs. Are there any distortions in the drawings? Discuss your findings.
2. Write a brief report about the contents of John Graunt's *Bills of Mortality*.
3. Write a paragraph about how statistics are used in sports.
4. Write a report on how surveys are used to determine the ratings and rankings of television programs by organizations such as A.C. Nielsen.
5. Discuss the Harris and Gallup polls and the techniques and types of statistics used in their surveys.
6. Prepare a report or an exhibit on how statistics are used in medicine, psychology, and/or business.
7. Research and write a report on how Gregor Mendel, Sir Francis Galton, and Florence Nightingale used statistics in their work.

> Summary Chapter 6

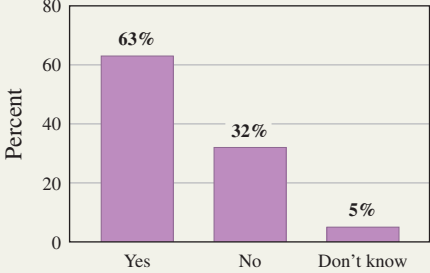
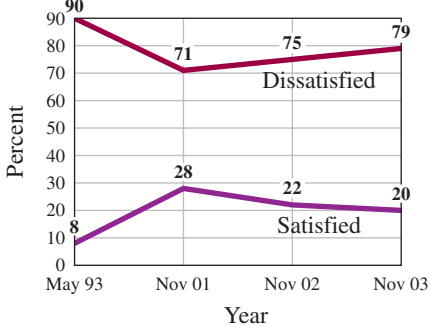
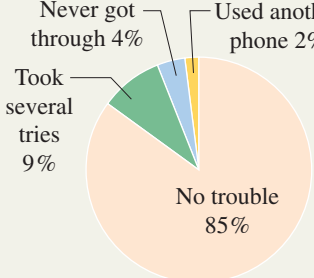
Section	Item	Meaning	Example
6.1B	Pictograph	A type of graph that uses symbols to represent numerical data.	<p>If each symbol represents 100 hamburgers sold,</p>  <p>means that 300 hamburgers have been sold.</p>
6.2A	Bar graph	A graph used to compare different categories by using bars whose lengths are proportional to the number of items in the category. The graph shows that most adults want to live to be 100.	<p>Do You Want a 100th Birthday?</p>  <p>Source: Data from USATODAY.com.</p>
6.2C	Line graph	A type of graph that usually shows a trend or change over time. The line graph shows the satisfaction or dissatisfaction of Americans with health care costs.	<p>Health Care Costs</p>  <p>Source: Data from The Gallup Organization.</p>
6.3A	Circle graph (pie chart)	A type of graph that shows what percent of a quantity is used in different categories or the ratio of one category to another.	<p>Trouble with Cell Phone Calls to 911</p>  <p>The circle graph shows the percent of people who had trouble when calling 911.</p>

Section	Item	Meaning	Example
6.4A	Mean	The mean of a set of n numbers is the sum of the numbers divided by n .	The mean of 7, 6, and 8 is $\frac{7+6+8}{3} = 7$.
6.4A	Weighted mean	The weighted mean of a set of n numbers is the sum of the products formed by multiplying each number by its assigned weight divided by the sum of all the weights.	Finding a grade point average (GPA).
6.4B	Median	The median of a set of numbers is the middle number when the numbers are arranged in ascending order.	The median of 5, 8, and 15 is 8. The median of 5, 8, 10, and 15 is $\frac{8+10}{2} = 9$.
6.4C	Mode	The number in a set that occurs most often. If no such number exists, there is no mode.	The mode of 3, 4, 5, 7, 4 is 4. The set 3, 4, 5, 6 has no mode.

Review Exercises Chapter 6

If you need help with these exercises, look in the section indicated in brackets.

1. < 6.1A > The table shows how much consumers are willing to pay for digital music and the potential revenue that can be derived from it.

Price Expectations of Digital Music

Price of digital song	\$0.01	\$0.50	\$0.99	\$1.49	\$1.99
Percent of market reached	89%	82%	74%	42%	39%
Potential revenue	N/A	\$992.20	\$1772.89	\$1514.44	\$1878.16

Source: Data from ClickZ Network.

- a. What percent of the market will be reached if the price per song is \$1.49?
- b. What percent of the market will be reached if the price per song is \$1.99?
- c. What is the potential revenue when the price is \$1.49 per song?
- d. What is the potential revenue when the price is \$1.99 per song?
- e. Which price per song would reach the highest percentage of the market?
2. < 6.1B > The pictograph shows the number of hamburgers sold at Burger King, Del Taco, Jack in the Box, McDonald's, and Wendy's. Each symbol represents 100 hamburgers.
- a. Which brand sold the most?
- b. Which brand sold the second most?
- c. How many Jack in the Box hamburgers were sold?
- d. How many McDonald's hamburgers were sold?
- e. How many Del Taco hamburgers were sold?

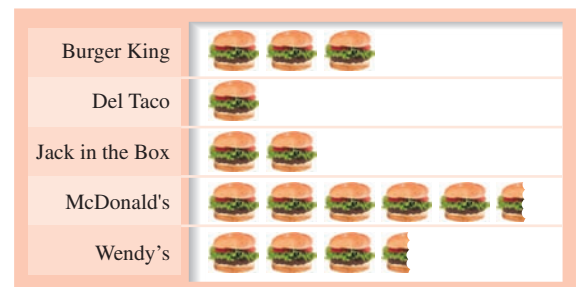

3. < 6.2A > The bar graph shows the percent of people who have downloaded music files from the Internet for playback at another time.

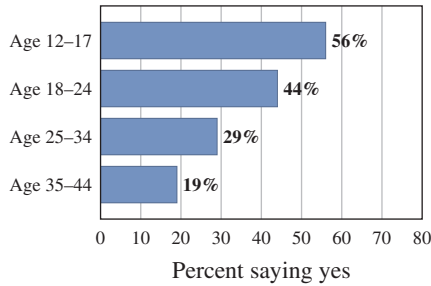

Source: Data from Edison Media Research.

- Which of the four age brackets has the second-highest percent of people who have downloaded music files?
 - Which of the four age brackets has the next-to-the-lowest percent of people who have downloaded music files?
 - What percent of the 18–24 age bracket downloaded music files?
 - What is the percent difference of downloaded music between the 25–34 and the 35–44 age brackets?
 - What is the percent difference of downloaded music between the age categories with the highest and lowest percent of downloads?
5. < 6.2B > The table shows the number of cell phone users from 2001 to 2005.

Year	Millions
2001	120
2002	140
2003	160
2004	170
2005	180

Use the years as the categories and the numbers (in millions) from 100 to 200 at 10-unit intervals as the frequencies and make a horizontal bar graph for the data.

Number of Cell Phone Users by Year

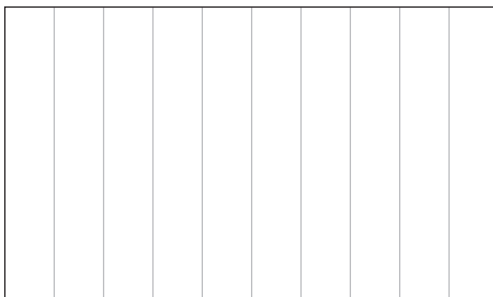

4. < 6.2B > In the same survey, the percents of consumers who have downloaded music and said they are purchasing more music are as follows:

Age	Percent
12–17	25%
18–24	25%
25–34	22%
35–44	28%

Use the age brackets as the categories and the percents from 0 to 50 as the frequencies and make a vertical bar graph for the data.

Consumers Who Have Downloaded Music and Said They Purchased More Music

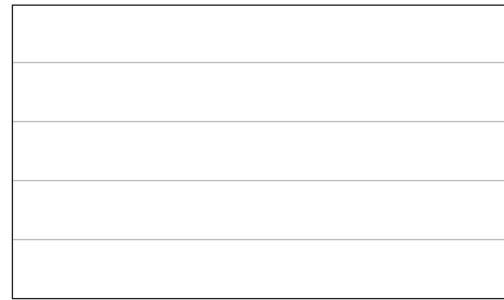

6. < 6.2C > The graph shows the total and senior populations (in millions) in the United States from 1950 to 2050.

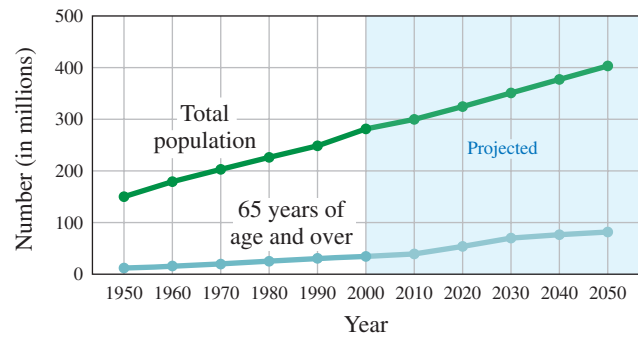

Source: Data from Centers for Disease Control and Prevention.

What was or would be the approximate total population:

- in 1960?
- in 1970?
- in 1990?
- in 2010?
- in 2020?

7. < 6.2C > Refer to the graph in Problem 6. What was or would be the approximate 65 years of age and older population in:
- 1960
 - 1980
 - 2020
 - 2040
 - 2050

8. < 6.2D > The chart shows the projected online spending (in billions) for college students, teens, and kids. Make a line graph of the spending for kids using a 0 to 1 billion vertical scale using 0.2-unit intervals.

Online Spending Forecast (in billions)			
	College Students	Teens	Kids
2003	\$4.5	\$1.7	\$0.2
2004	\$5.5	\$2.6	\$0.4
2005	\$6.4	\$3.6	\$0.7
2006	\$7.4	\$4.8	\$1.0

Source: Data from Jupiter Research, October 2001.

9. < 6.3A > The circle graph shows the percent of people who believe that the most popular place for proposing marriage is as shown in the graph.

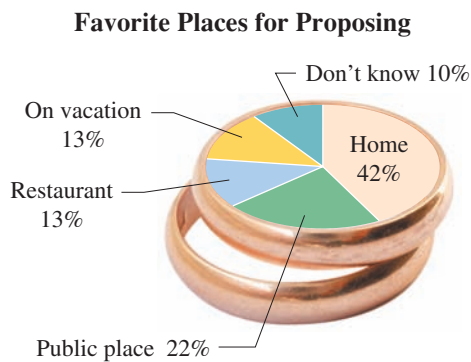

Source: Data from StrategyOne for Korbel Champagne.

- What percent of the people chose “restaurant”?
- What percent of the people chose “home”?
- What percent of the people chose “public place”?
- Which was believed to be the most popular place for proposing?
- What was the percent difference between the people who chose home as the most popular place and those who chose a public place?

Online Spending Forecast for Kids

10. < 6.3A > Refer to the circle graph in Problem 9. Suppose 1000 people were surveyed. How many people would choose:
- Don't know?
 - On vacation?
 - Restaurant?
 - Public place?
 - Home?

11. < 6.3B > Make a circle graph to show the ways we commute to work.

Category	Percent
Drive alone (DA)	70%
Car pool (CP)	10%
Public transit (PT)	5%
Other (O)	15%

Ways We Commute to Work

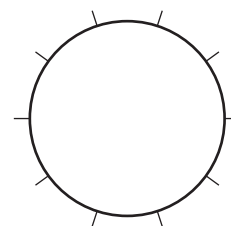

12. < 6.4A, B, C > The table shows the price (in cents) of five different fast-food chain hamburgers.

Category	Price (cents)
Burger King	79
Del Taco	99
McDonald's	99
Jack in the Box	99
Wendy's	89

Source: Data from Fast Food Source.com.

- Find the mean price for the five hamburgers.
 - Find the median price for the five hamburgers.
 - Find the mode for the price of the five hamburgers.
 - Find the mean price of the first four hamburgers.
 - Find the median price of the first four hamburgers.
14. < 6.4A > A student is taking five courses with the credit hours and points earned shown. To one decimal place, what is the student's GPA?

Course	Credit Hours	Grade (Points Earned)
V	3	C(2)
W	3	B(3)
X	4	C(2)
Y	1	A(4)
Z	3	A(4)

13. < 6.4A, B, C > The table shows the fat content (in grams) of five different fast-food chain hamburgers.

Category	Fat (grams)
Burger King	17
Del Taco	13
McDonald's	18
Jack in the Box	14
Wendy's	12

Source: Data from Fast Food Source.com.

- Find, to the nearest gram, the mean fat content for the five hamburgers.
 - Find the median fat content for the five hamburgers.
 - Find the mode, if it exists, for the fat content of the five hamburgers.
 - Find, to the nearest gram, the mean fat content of the first four hamburgers.
 - Find, to the nearest gram, the median fat content of the first four hamburgers.
15. < 6.4A > A student is taking five courses with the credit hours and points earned shown. To one decimal place, what is the student's GPA?

Course	Credit Hours	Grade (Points Earned)
V	3	B(3)
W	2	D(1)
X	3	C(2)
Y	4	A(4)
Z	3	A(4)

Practice Test Chapter 6

Visit www.mhhe.com/bello to view helpful videos that provide step-by-step solutions to several of the problems below. (Answers on page 427)

1. The table shows how much consumers are willing to pay for digital music and the potential revenue that can be derived from it.

Price Expectations of Digital Music					
Price of digital song	\$0.01	\$0.50	\$0.99	\$1.49	\$1.99
Percentage of market reached	89%	82%	74%	42%	39%
Potential revenue	N/A	\$992.20	\$1772.89	\$1514.44	\$1878.16

Source: Data from ClickZ Network.

- a. What percent of the market will be reached if the price per song is \$0.99?
 b. What is the potential revenue when the price is \$0.99 per song?
2. The pictograph shows the number of hamburgers sold at Burger King, Del Taco, Jack in the Box, McDonald's, and Wendy's. Each symbol represents 100 hamburgers.
3. The bar graph shows the percent of people who have downloaded music files from the Internet for playback at another time.

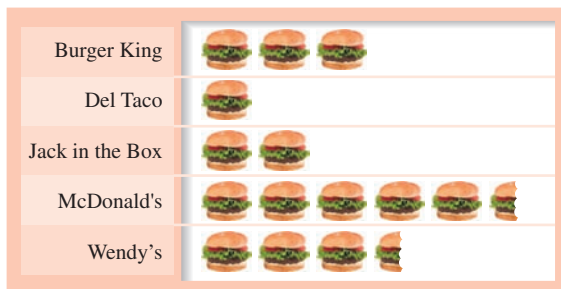

- a. Which brand sold the most?
 b. How many Wendy's hamburgers were sold?
4. In the same survey, the percents of consumers who have downloaded music and said they are purchasing more music are as follows:

Age	Percent
12–17	20%
18–24	20%
25–34	22%
35–44	25%

Use the age brackets as the categories and the percents from 0 to 40 as the frequencies and make a vertical bar graph for the data.

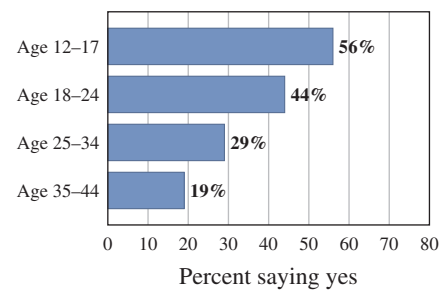

Source: Data from Edison Media Research.

- a. Which of the four age brackets has the lowest percent of people who have downloaded music files?
 b. What percent of the 25–34 age bracket downloaded music files?
5. The graph shows the total and senior populations (in millions) from 1950 to 2050.

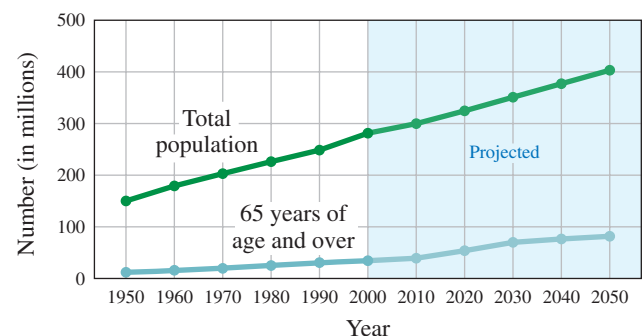

Source: Data from Centers for Disease Control and Prevention.

- a. What is the approximate projected total population for the year 2030?
 b. What is the approximate projected 65 years of age and over population for the year 2020?

6. The chart shows the projected online spending (in billions) for college students, teens, and kids.

	College Students	Teens	Kids
2003	\$4.5	\$1.7	\$0.2
2004	\$5.5	\$2.6	\$0.4
2005	\$6.4	\$3.6	\$0.7
2006	\$7.4	\$4.8	\$1.0

Source: Data from Jupiter Research, October 2001.

Make a line graph of the spending for college students using a 1–10 billion vertical scale.

8. Based on the information given in the following table, make a circle graph to show the ways we commute to work.

Category	Percent
Drive alone (DA)	80%
Car pool (CP)	10%
Public transit (PT)	5%
Other (O)	5%

Source: Data from National Public Transportation Survey.

10. A student is taking five courses with the credit hours and points earned shown. To one decimal place, what is the student's GPA?

Course	Credit Hours	Grade (Points Earned)
V	3	B(3)
W	3	B(3)
X	4	C(2)
Y	1	A(4)
Z	3	A(4)

7. The circle graph shows the percent of people who believe that the most popular place for proposing marriage is as shown in the graph.

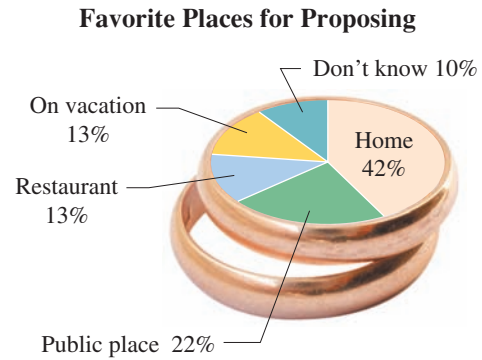

Source: Data from StrategyOne for Korbel Champagne.

- What percent of the people chose “on vacation”?
 - If 500 people were surveyed, how many would have chosen “on vacation”?
9. The table shows the milligrams (mg) of cholesterol in five different fast-food chain hamburgers.
- Find the mean number of grams of cholesterol for the hamburgers.
 - Find the median number of grams of cholesterol for the hamburgers.
 - Find the mode(s) of the number of grams of cholesterol for the hamburgers.

Category	Cholesterol (mg)
Burger King	50
Del Taco	35
McDonald's	60
Jack in the Box	45
Wendy's	45

Source: Data from Fast Food Source.com.

> Answers to Practice Test Chapter 6

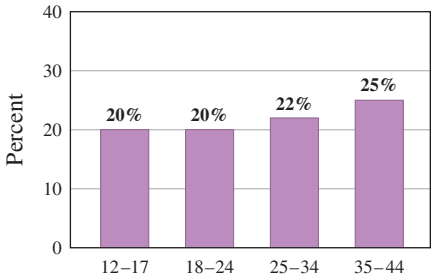
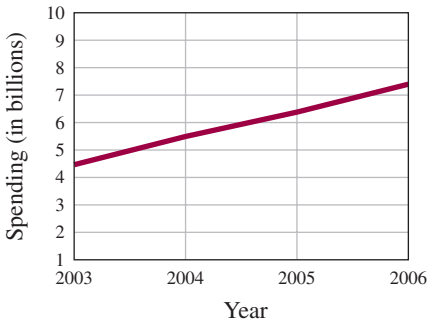
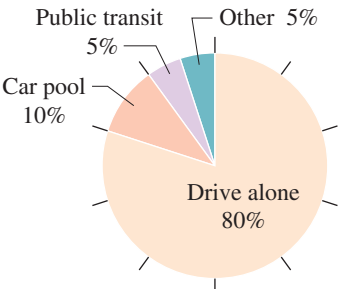
Answer	If You Missed	Review												
	Question	Section	Examples	Page										
1. a. 74% b. \$1772.89	1	6.1	1	372–373										
2. a. McDonald's b. 350	2	6.1	3–5	374–375										
3. a. 35–44 age bracket b. 29	3	6.2	1, 2	380–381										
4. Purchasing More Music	4	6.2	3, 4	381–382										
 <table border="1" style="margin-left: auto; margin-right: auto;"> <caption>Purchasing More Music</caption> <thead> <tr> <th>Age Group</th> <th>Percent</th> </tr> </thead> <tbody> <tr> <td>12–17</td> <td>20%</td> </tr> <tr> <td>18–24</td> <td>20%</td> </tr> <tr> <td>25–34</td> <td>22%</td> </tr> <tr> <td>35–44</td> <td>25%</td> </tr> </tbody> </table>	Age Group	Percent	12–17	20%	18–24	20%	25–34	22%	35–44	25%				
Age Group	Percent													
12–17	20%													
18–24	20%													
25–34	22%													
35–44	25%													
5. a. About 350 million b. About 50 million	5	6.2	5	383										
6. Online Spending Forecast	6	6.2	6	384										
 <table border="1" style="margin-left: auto; margin-right: auto;"> <caption>Online Spending Forecast</caption> <thead> <tr> <th>Year</th> <th>Spending (in billions)</th> </tr> </thead> <tbody> <tr> <td>2003</td> <td>4.5</td> </tr> <tr> <td>2004</td> <td>5.5</td> </tr> <tr> <td>2005</td> <td>6.5</td> </tr> <tr> <td>2006</td> <td>7.5</td> </tr> </tbody> </table>	Year	Spending (in billions)	2003	4.5	2004	5.5	2005	6.5	2006	7.5				
Year	Spending (in billions)													
2003	4.5													
2004	5.5													
2005	6.5													
2006	7.5													
7. a. 13% b. 65	7	6.3	1, 2, 3	397–398										
8. Ways to Commute to Work	8	6.3	4	400										
 <table border="1" style="margin-left: auto; margin-right: auto;"> <caption>Ways to Commute to Work</caption> <thead> <tr> <th>Way</th> <th>Percentage</th> </tr> </thead> <tbody> <tr> <td>Drive alone</td> <td>80%</td> </tr> <tr> <td>Car pool</td> <td>10%</td> </tr> <tr> <td>Public transit</td> <td>5%</td> </tr> <tr> <td>Other</td> <td>5%</td> </tr> </tbody> </table>	Way	Percentage	Drive alone	80%	Car pool	10%	Public transit	5%	Other	5%				
Way	Percentage													
Drive alone	80%													
Car pool	10%													
Public transit	5%													
Other	5%													
9. a. 47 b. 45 c. 45	9	6.4	1, 2, 4, 5	409, 411–412										
10. 3.0	10	6.4	3	410										

Cumulative Review Chapters 1–6

- Write six thousand, five hundred ten in standard form.
- Simplify: $4 \div 2 \cdot 2 + 9 - 6$
- Classify $\frac{2}{9}$ as proper or improper.
- Write $\frac{25}{8}$ as a mixed number.
- Write $2\frac{1}{6}$ as an improper fraction.
- Multiply: $(\frac{6}{5})^2 \cdot \frac{1}{36}$
- Divide: $\frac{15}{2} \div 4\frac{1}{6}$
- Translate and solve: $\frac{3}{4}$ less than a number z is $\frac{3}{8}$. What is z ?
- Find a number such that $\frac{8}{9}$ of it is $4\frac{1}{4}$.
- Give the word name for 352.51.
- Write 64.175 in expanded form.
- Subtract: $541.42 - 12.5$
- Multiply: $59.9 \cdot 0.013$
- Divide: $\frac{126}{0.21}$
- Round 749.851 to the nearest tenth.
- Divide: $80 \div 0.13$ (Round the answer to two decimal digits.)
- Write $0.\overline{78}$ as a reduced fraction.
- What decimal part of 30 is 9?
- Arrange in order of decreasing magnitude and write the inequality using the $>$ sign: 9.568 $9.5\overline{68}$ $9.5\overline{68}$
- Insert $=$, $<$, or $>$ to make a true statement.
 0.53 _____ $\frac{19}{20}$
- Solve for x : $x + 3.7 = 7.9$
- Solve for y : $4.5 = 0.5y$
- Solve for z : $4 = \frac{z}{3.3}$
- The ratio of cars to people in New Zealand is 280 to 1000. Write this ratio as a fraction in reduced form.
- Write the following proportion: 4 is to 7 as 28 is to x .
- There is a law stating that “the ratio of width to length for the American flag should be 10 to 19.” Is a flag measuring 40 by 76 feet of the correct ratio?
- Solve the proportion: $\frac{x}{2} = \frac{2}{8}$
- Solve the proportion: $\frac{10}{p} = \frac{2}{3}$
- A student traveled 500 miles on 19 gallons of gas. How many miles per gallon did the student get? (Round to the nearest whole number.)
- A 20-ounce jar of popcorn costs \$2.49. What is the unit price in cents per ounce? (Answer to the nearest cent.)
- A pound of fertilizer covers 1000 square feet of lawn. How many pounds are needed to cover a lawn measuring 80 by 50 feet (4000 square feet)?
- The protein RDA for females is 52 grams per day. Three ounces of a certain product provide four grams of protein. How many ounces of the product are needed to provide 52 grams of protein?
- Write 67% as a decimal.
- Write $3\frac{3}{4}\%$ as a decimal.
- Write 0.09 as a percent.
- 80% of 60 is what number?
- What is $66\frac{2}{3}\%$ of 54?
- What percent of 32 is 16?
- 12 is 40% of what number?
- The sales tax rate in a certain state is 4%. Find the total price paid for a pair of shoes that costs \$18.

41. Find the simple interest earned on \$300 invested at 4.5% for 5 years.

42. The following table shows the distribution of families by income in Racine, Wisconsin.

Income Level	Percent of Families
\$0–9999	3
10,000–14,999	10
15,000–19,999	27
20,000–24,999	33
25,000–34,999	10
35,000–49,999	9
50,000–79,999	4
80,000–119,000	3
120,000 and over	1

43. The following graph represents the yearly rainfall in inches in Sagamore County for 2001–2006. Find the rainfall for 2001.

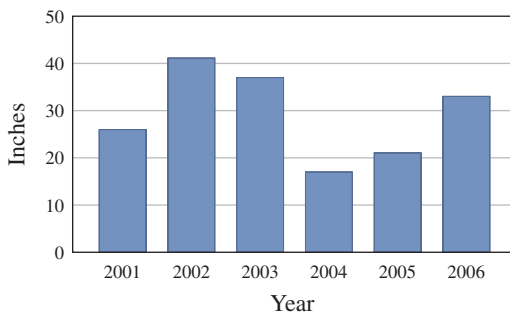

What percent of the families in Racine have incomes between \$15,000 and \$19,999?

44. The following graph represents the monthly average temperature for seven months of the year. How much higher is the average temperature in May than it is in March?

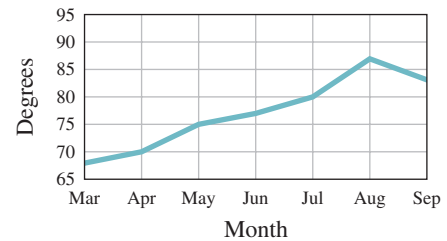

45. The number of hours required in each discipline of a college core curriculum is represented by the following circle graph. What percent of these hours is in P.E. and art combined?

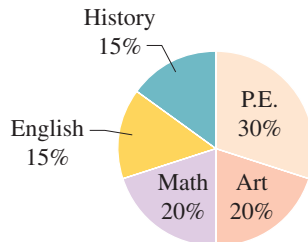

46. What is the mode of the following set of numbers?
2, 23, 16, 21, 12, 2, 9, 2, 6, 2

47. What is the mean of the following set of numbers?
3, 2, 30, 17, 2, 2, 2, 18, 3, 4, 16

48. What is the median of the following set of numbers?
4, 7, 24, 4, 18, 14, 23, 6, 29, 29, 29

This page intentionally left blank

Section

Chapter

- 7.1** Length: U.S. System
- 7.2** Length: The Metric System
- 7.3** Length: U.S. to Metric and Metric to U.S. Conversions
- 7.4** Area: U.S., Metric, and Conversions
- 7.5** Volume (Capacity): U.S., Metric, and Conversions
- 7.6** Weight and Temperature: U.S., Metric, and Conversions

7

seven

▶ Measurement and the Metric System



The Human Side of Mathematics

Here is a quiz for you: name one country that uses the metric system. Almost any country will do *except* the United States. Take a romantic vacation in France. It is a cool day; so you take a 30-minute walk to a nearby village, get some cheese and some wine. The temperature (in degrees Celsius, not Fahrenheit), the distance (kilometers, not miles), the cheese (kilograms, not pounds), and the wine (liters, not quarts) are all in the metric system. How did this happen?

Weights and measures are among the earliest tools invented by humans. Babylonians and Egyptians measured length with the forearm, hand, or finger, but the system used in the United States is based on the English system. The need for a single, worldwide, coordinated system of measurement was recognized over 300 years ago by Gabriel Mouton, vicar of St. Paul's Church in Lyon, France. In 1790, the National Assembly of France requested the French Academy of Sciences to “deduce an invariable standard for all measures and weights.” The result was the metric system, made compulsory in France in 1840. What about the United States? As early as 1789, Thomas Jefferson submitted a report proposing a decimal-based system of measurement. Congress took no action on his proposal, but later, in 1832, he directed the Treasury Department to standardize the measures used by customs officials at U.S. ports. Congress allowed this report to stand without taking any formal action. Finally, in 1866, Congress legalized the use of the metric system and in 1875, the United States became one of the original signers of the Treaty of the Meter.

7.1 Length: U.S. System

Objectives

You should be able to:

A > Convert a given measure in the U.S. system to an equivalent one also in the U.S. system.

B > Solve applications involving U.S. units of length.

To Succeed, Review How To . . .

Multiply and divide fractions and decimals. (pp. 135–140, 222–226)

Getting Started

In the cartoon, Hugo is **measuring** the board and finds it to be $31\frac{1}{2}$ inches. When we measure an object, we assign a **number** to it that indicates the size of the object, in this case, $31\frac{1}{2}$.

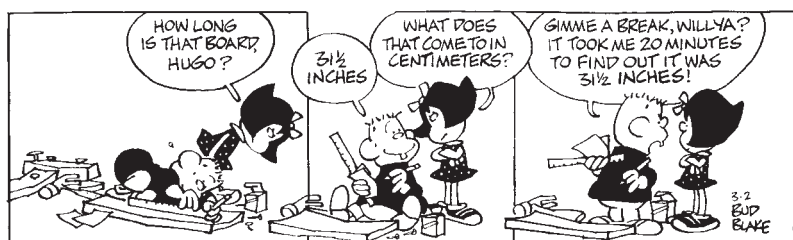

TIGER © 1976 KING FEATURES SYNDICATE

We also use **units** (such as inches) comparing the quantity being measured to some standard unit. Thus, any measurement involves two things:

1. A *number* (whole, fraction, or decimal)
2. A *unit*

Suppose \overline{AB} is a unit segment. Using \overline{AB} as our standard, we can measure other segments such as \overline{CD} .



Since the segment \overline{CD} contains three of the \overline{AB} segments end to end, we say that the segment \overline{CD} is three units long. When the length of a segment is not a whole number, we can use fractional parts to indicate the length. Thus, the length of segment \overline{EF} is $2\frac{1}{2}$ units.



A standard ruler shows the units we use in everyday life.

Converting U.S. Units of Length

There are two major systems of measurement, the **U.S. customary** or **American system** and the **metric** system, which will be covered in Section 7.2.* In ancient times most units were based on measurements related to the body. For example, the **inch** originated with

*The U.S. (American) system used to be called the English system, but the English have changed to the metric system, so we call this system the U.S. customary or American system.

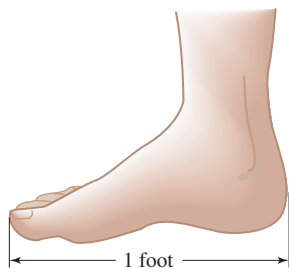

the Greeks, who based it on the breadth of the thumb. (The word for *inch* in Spanish is *pulgada*, a word derived from the word *pulgar*, meaning thumb. The Latin word for inch is *uncia*, which means $\frac{1}{12}$, later evolving into inch.) The **foot** was the length of a man's foot, and a **yard** was the distance around (circumference of) a person's waist (*gird* in Saxon, later evolving into *yard*). It is said that Henry I decreed that the yard should be the distance from the tip of his nose to the end of his thumb. The problem with these units is that their size depends on whose finger, foot, or arm you use. To alleviate this problem, the yard was defined to be the distance between marks on a brass bar kept in London. The foot was exactly $\frac{1}{3}$ of this standard yard and the inch, exactly $\frac{1}{36}$ of the yard.

These relationships and the abbreviations used are given in the table.

To change from one unit to another, we can make *substitutions*, treating the names of the units as if they were numbers. For example, to find how many inches are in a yard, we write

$$1 \text{ yard} = 3 \text{ ft} = 3 \cdot (12 \text{ in.}) = 36 \text{ in.}$$

U.S. Units of Length

$$1 \text{ foot (ft)} = 12 \text{ inches (in.)}$$

$$1 \text{ yard (yd)} = 3 \text{ ft}$$

$$1 \text{ mile (mi)} = 5280 \text{ ft}$$

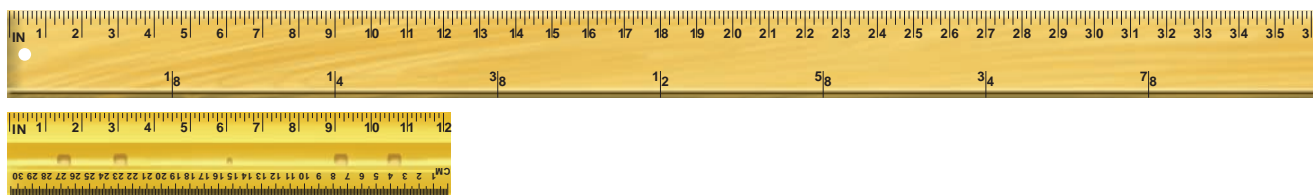

EXAMPLE 1 Converting yards to inches

$$2 \text{ yd} = \underline{\hspace{2cm}} \text{ in.}$$

SOLUTION 1

$$1 \text{ yd} = 3 \text{ ft}$$

$$2 \text{ yd} = 6 \text{ ft} = 6 \cdot 12 \text{ in.} = 72 \text{ in.}$$

$$\text{Thus, } 2 \text{ yd} = 72 \text{ in.}$$

PROBLEM 1

$$3 \text{ yd} = \underline{\hspace{2cm}} \text{ in.}$$

How do we convert from a smaller unit to a larger one? For example,

$$60 \text{ in.} = \underline{\hspace{2cm}} \text{ ft}$$

First, note that there are 12 inches in a foot; thus, there is $\frac{1}{12}$ of a foot in an inch. Also, $3 \text{ ft} = 1 \text{ yd}$, so $1 \text{ ft} = \frac{1}{3} \text{ yd}$. Finally, $1 \text{ mi} = 5280 \text{ ft}$, so $1 \text{ ft} = \frac{1}{5280} \text{ mi}$. The information is summarized as follows:

$$1 \text{ in.} = \frac{1}{12} \text{ ft}$$

$$1 \text{ ft} = \frac{1}{3} \text{ yd}$$

$$1 \text{ ft} = \frac{1}{5280} \text{ mi}$$

To solve the problem $60 \text{ in.} = \underline{\hspace{2cm}} \text{ ft}$, we can now use a procedure similar to that used in Example 1. Thus,

$$60 \text{ in.} = 60 \cdot \left(\frac{1}{12} \text{ ft}\right) = \frac{60}{12} \text{ ft} = 5 \text{ ft}$$

Another method of conversions involves **unit fractions**—that is, fractions that equal 1. For example, since

$$1 \text{ ft} = 12 \text{ in.},$$

$$1 = \frac{12 \text{ in.}}{\text{ft}} \quad \text{and} \quad 1 = \frac{\text{ft}}{12 \text{ in.}}$$

Answers to PROBLEMS

1. 108 in.

are both unit fractions. To use unit fractions to convert 60 inches to feet, we use the second of these fractions (because it has the desired units in the numerator). Thus,

$$60 \text{ in.} = 60 \text{ in.} \cdot 1 = 60 \text{ in.} \cdot \frac{\text{ft}}{12 \text{ in.}} = \frac{60}{12} \text{ ft} = 5 \text{ ft}$$

We shall work the examples using both the substitution and the unit fraction methods.

EXAMPLE 2 Converting inches to feet

$$76 \text{ in.} = \underline{\hspace{2cm}} \text{ ft}$$

SOLUTION 2

$$\text{Method 1. } 76 \text{ in.} = 76 \cdot \frac{1}{12} \text{ ft} = \frac{76}{12} \text{ ft} = 6\frac{1}{3} \text{ ft}$$

$$\text{Thus, } 76 \text{ in.} = 6\frac{1}{3} \text{ ft.}$$

$$\text{Method 2. } 76 \text{ in.} = 76 \text{ in.} \cdot 1 = 76 \text{ in.} \cdot \frac{\text{ft}}{12 \text{ in.}} = \frac{76}{12} \text{ ft} = 6\frac{1}{3} \text{ ft}$$

PROBLEM 2

$$40 \text{ in.} = \underline{\hspace{2cm}} \text{ ft}$$

EXAMPLE 3 Converting inches to feet

$$11 \text{ in.} = \underline{\hspace{2cm}} \text{ ft}$$

SOLUTION 3

$$\text{Method 1. } 11 \text{ in.} = 11 \cdot \frac{1}{12} \text{ ft} = \frac{11}{12} \text{ ft}$$

$$\text{Thus, } 11 \text{ in.} = \frac{11}{12} \text{ ft.}$$

$$\text{Method 2. } 11 \text{ in.} = 11 \text{ in.} \cdot 1 = 11 \text{ in.} \cdot \frac{\text{ft}}{12 \text{ in.}} = \frac{11}{12} \text{ ft}$$

PROBLEM 3

$$7 \text{ in.} = \underline{\hspace{2cm}} \text{ ft}$$

EXAMPLE 4 Converting feet to yards

$$26 \text{ ft} = \underline{\hspace{2cm}} \text{ yd}$$

SOLUTION 4

$$\text{Method 1. } 26 \text{ ft} = 26 \cdot \frac{1}{3} \text{ yd} = \frac{26}{3} \text{ yd} = 8\frac{2}{3} \text{ yd}$$

$$\text{Thus, } 26 \text{ ft} = 8\frac{2}{3} \text{ yd.}$$

$$\text{Method 2. } \text{Since } 3 \text{ ft} = 1 \text{ yd, } 1 = \frac{\text{yd}}{3 \text{ ft}}. \text{ Thus,}$$

$$26 \text{ ft} = 26 \text{ ft} \cdot 1 = 26 \text{ ft} \cdot \frac{\text{yd}}{3 \text{ ft}} = \frac{26}{3} \text{ yd} = 8\frac{2}{3} \text{ yd}$$

PROBLEM 4

$$38 \text{ ft} = \underline{\hspace{2cm}} \text{ yd}$$

EXAMPLE 5 Converting feet to miles

$$15,840 \text{ ft} = \underline{\hspace{2cm}} \text{ mi}$$

SOLUTION 5

$$\text{Method 1. } 15,840 \text{ ft} = 15,840 \cdot \frac{1}{5280} \text{ mi} = \frac{15,840}{5280} \text{ mi} = 3 \text{ mi}$$

$$\text{Thus, } 15,840 \text{ ft} = 3 \text{ mi.}$$

$$\text{Method 2. } 15,840 \text{ ft} = 15,840 \text{ ft} \cdot 1 = 15,840 \text{ ft} \cdot \frac{\text{mi}}{5280 \text{ ft}}$$

$$= \frac{15,840}{5280} \text{ mi} = 3 \text{ mi}$$

PROBLEM 5

$$10,560 \text{ ft} = \underline{\hspace{2cm}} \text{ mi}$$

EXAMPLE 6 Converting feet to inches

$$2 \text{ ft} = \underline{\hspace{2cm}} \text{ in.}$$

SOLUTION 6

$$\text{Method 1. } 2 \text{ ft} = 2 \cdot 12 \text{ in.} = 24 \text{ in.}$$

$$\text{Thus, } 2 \text{ ft} = 24 \text{ in.}$$

$$\text{Method 2. } 2 \text{ ft} = 2 \text{ ft} \cdot 1 = 2 \text{ ft} \cdot \frac{12 \text{ in.}}{\text{ft}} = 24 \text{ in.}$$

PROBLEM 6

$$4 \text{ ft} = \underline{\hspace{2cm}} \text{ in.}$$

Answers to PROBLEMS

2. $3\frac{1}{3}$ ft 3. $\frac{7}{12}$ ft 4. $12\frac{2}{3}$ yd
5. 2 mi 6. 48 in.

B > Applications Involving U.S. Units of Length

EXAMPLE 7 Converting height from feet to inches

How tall are you? Probably not as tall as Angus MacAskill, the tallest “true” (nonpathological) giant, who measured 7.75 feet. How many inches is that?

SOLUTION 7

Method 1. $7.75 \text{ ft} = 7.75 \cdot \overbrace{12 \text{ in.}} = 93 \text{ in.}$ 7.75

Method 2. $7.75 = 7.75 \text{ ft} \cdot 1$ $\times 12$
 $= 7.75 \text{ ft} \cdot \frac{12 \text{ in.}}{\text{ft}} = 93 \text{ in.}$ $\frac{15 \ 50}{77 \ 5}$
 $\frac{93.00}{}$

PROBLEM 7

One of the tallest living humans was John Carroll, who measured 8.75 feet tall. How many inches is that?

GREEN MATH

EXAMPLE 8 Global warming and sea level

In the last 100 years the Earth’s temperature has increased about half a degree Celsius and the sea level has risen 6 to 8 inches. Change 6 inches to feet.

SOLUTION 8

Method 1. $6 \text{ in.} = 6 \cdot \frac{1}{12} \text{ ft} = \frac{6}{12} \text{ ft} = \frac{1}{2} \text{ ft}$

Thus, $6 \text{ in.} = \frac{1}{2} \text{ ft}$

Method 2. $6 \text{ in.} = 6 \text{ in.} \cdot 1 = 6 \text{ in.} \cdot \frac{\text{ft}}{12 \text{ in.}} = \frac{6}{12} \text{ ft} = \frac{1}{2} \text{ ft}$

You don’t have to use both methods. Use the one you like best!

Source: <http://tinyurl.com/krxzsl>.

PROBLEM 8

Change 8 inches to feet.

Before you try the exercises, let us talk about estimation. Look at Example 1, where we are converting 2 yards to inches. Since the yard contains many inches (36 to be exact), your estimated answer must be much larger than 2. As a matter of fact, if you remembered that one yard is 36 inches, it would be exactly twice the 36 or $2 \cdot 36 = 72$ inches as in the example.

On the other hand, in Example 5 we are converting 15,840 feet to miles. Since 1 foot is much smaller than a mile ($\frac{1}{5280}$ of a mile, to be exact), your estimated answer must be much smaller than 15,840, a fraction of it, $\frac{1}{5280}$ of the 15,840, to be exact. Now, try the exercises and remember to estimate before you give the final answer!

> Exercises 7.1



> Practice Problems > Self-Tests
 > Media-rich eBooks > e-Professors > Videos

< A > Converting U.S. Units of Length In Problems 1–30, fill in the blank.

1. 4 yd = _____ in.

2. 5 yd = _____ in.

3. 2.5 yd = _____ in.

4. 1.5 yd = _____ in.

5. $2\frac{1}{3}$ yd = _____ in.

6. $1\frac{1}{4}$ yd = _____ in.

7. 50 in. = _____ ft

8. 72 in. = _____ ft

9. 84 in. = _____ ft

Answers to PROBLEMS

7. 105 in. 8. $\frac{2}{3}$ ft

- | | | |
|------------------------|--------------------------|------------------------|
| 10. 30 in. = _____ ft | 11. 3 in. = _____ ft | 12. 4 in. = _____ ft |
| 13. 9 in. = _____ ft | 14. 5 in. = _____ ft | 15. 30 ft = _____ yd |
| 16. 33 ft = _____ yd | 17. 37 ft = _____ yd | 18. 32 ft = _____ yd |
| 19. 5280 ft = _____ mi | 20. 26,400 ft = _____ mi | 21. 4 ft = _____ in. |
| 22. 5 ft = _____ in. | 23. 1 yd = _____ ft | 24. 3 yd = _____ ft |
| 25. 1 mi = _____ ft | 26. 2 mi = _____ ft | 27. 1 mi = _____ yd |
| 28. 3 mi = _____ yd | 29. 1760 yd = _____ mi | 30. 3520 yd = _____ mi |

< B > Applications Involving U.S. Units of Length

> > > Applications: Green Math

Global Warming in Antarctica

31. Antarctica is covered with ice an average of 7000 feet thick. If all of the Antarctic ice melted, sea levels around the world would rise about 200 feet.
- Change 7000 ft to miles.
 - Change 200 ft to yards.

Source: <http://tinyurl.com/krxzsl>.

33. *Stove* The opening for the stove in a new home is $2\frac{1}{2}$ ft wide.
- How many inches is that?
 - Would a 28 in. wide stove fit?
35. *Tibet* Lhasa, the capital of Tibet, is 12,087 ft above sea level. How many yards is that?
37. *Cars* The longest production car was the Bugatti Royale Type 41. It was 22 feet 1 in. long. How many inches is that?
39. *Horse races* Horse races are measured in furlongs. If a furlong is 220 yd, what is the length in miles of an 8-furlong race?
41. *Dog jumps* One of the highest dog jumps was made by Young Sabre, a German shepherd, who scaled an 11.75 ft wall. How many inches is that?
43. *Height* The average woman is 5 ft 4 in. tall. How many inches is that?
45. *Snakes* A snake's average speed is 2 mi/hr. How many feet per hour is that?

47. *Walking speed* The average urbanite walks about 6 ft per second.
- How many yards per second is that?
 - How many yards would an urbanite go in one minute?
49. *Dessert* The longest banana split ever made was 4 mi 686 yd long. How many feet is that? However, a 4.55-mile banana split was made in Selinsgrove, Pennsylvania, in 1988. Which is longer? (*Hint:* 0.55 miles is 0.55×5280 ft)

32. There is a significant amount of ice covering **Greenland**, which would add another 20 feet to the oceans if it melted.

- Change 20 ft to inches.
- Change 20 ft to yards.

34. *Baseball* Mickey Mantle hit the longest officially measured home run in a major league game, 565 ft. How many yards is that?
36. *Battleships* The U.S.S. *New Jersey* is the longest battleship, 888 ft. How many yards is that?
38. *Bananas* A banana must be 8 in. long to qualify for the Chiquita label. How many feet is that?
40. *Height* A woman is 5 ft 8 in. in height. How many inches is that?
42. *Birds* The largest flying bird (prehistoric) had a wing span of 24 ft. How many yards is that?
44. *Height* The average man is 5 ft 9 in. tall. How many inches is that?
46. *Plants* Water rises inside a plant's stem an average of 4 ft every hour.
- How many inches is that?
 - If a plant is 72 in. tall, how long would it take for water to travel from the bottom to the top of the plant?
48. *Walking speed* The average urbanite walks about 2 yd per second.
- How many seconds would it take to go 100 yd?
 - How many seconds would it take to go 440 yd?
50. *Food* One of the longest sausages recorded was 9.89 mi long. How many feet is that? (Answer to the nearest foot.) The Nowicki Sausage Show made a sausage 8773 ft long. How many miles is that? Is it longer than the 9.89 mi sausage?

- 51. Cheetah speed** The cheetah is believed to be the fastest animal on land. It can run as fast as 102 ft per second. How many yards per second is that?
- 53. 100-yard dash** Houston McTear, who ran for Baker High School in Florida during the early 1970s, is credited with being the only man to ever run the 100-yard dash in 9 seconds. How many feet per second is that? Write the answer as a mixed number.
- 55. Travel** You are traveling on the Kentucky Parkway but it ends in 2500 ft.



- a.** How many yards is that? Write the answer as a mixed number.

- 52. Antelope speed** An antelope can run at 87 ft per second. How many yards per second is that?
- 54. Travel** You are traveling along and you see this sign. How many yards away is the road closure? Write the answer as a mixed number.



- b.** If you are traveling at 60 miles per hour, you are moving at about 29 yd/sec. Can you prove that?
- c.** If you are traveling at 60 miles per hour and the Parkway ends in 2500 ft, in how many seconds will the Parkway end? Answer to the nearest second.

>>> Using Your Knowledge

World Records When the measurement of an item is used in setting world records, the results and claims can be varied. For example, if you research the “longest sausage,” several claims surface. We report some of the claims; you decide which one is the longest! Convert each measurement to feet first.

- 56.** A 28-mi, 1354-yd sausage in Ontario, Canada (1995).
- 57.** The Sheffield, England, sausage, 36.75 mi long (Oct. 2000).
- 58.** A super-sausage reported on the Internet, 13 mi long (<http://website.lineone.net>).

>>> Write On

- 59.** Write in your own words how you think the names of the units for the American system (inches, yards, feet, and miles) originated.
- 60.** Write in your own words how you use estimation when converting from one American unit to another.
- 61.** Write in your own words the two methods used in this text to convert from one American unit to another one.
- 62.** Which of the two methods used to convert from one American unit to another do you prefer? Explain why.

>>> Concept Checker

Fill in the blank(s) with the correct word(s), phrase or mathematical statement.

- 63.** The **two major systems** of measurement are the _____ system and the _____ system.
- 64.** The _____ was the **circumference** of a person’s waist.

metric	U.S.
foot	yard
meter	

>>> Mastery Test

65. Tom is 6.5 feet tall. Convert his height to inches.

In Problems 66–72, fill in the blank.

66. 6 ft = _____ in.

67. 31,680 ft = _____ mi

68. 3 mi = _____ ft

69. 25 ft = _____ yd

70. 11 in. = _____ ft

71. 75 in. = _____ ft

72. 31 ft = _____ yd

>>> Skill Checker

Perform the indicated operations.

73. $4232 \div 1000$

74. $3 \div 10$

75. $83.5 \cdot 100$

76. $340 \cdot 10$

77. $100 \cdot 0.465$

7.2

Length: The Metric System

▶ Objective

You should be able to:

- A** > Convert a metric unit of length to an equivalent metric unit of length.

▶ To Succeed, Review How To . . .

1. Multiply by powers of 10 (10, 100, 1000, etc.). (pp. 223–224)
2. Divide by powers of 10. (pp. 227–228)

▶ Getting Started

In the cartoon the girl is very upset about thinking metric. Actually, the metric system is used by most nations in the world, with one notable exception—the United States. The system was invented many years ago, and it divides the distance from the Earth's equator to the North Pole into 10 million equal parts, each called a **meter**. (The official definition of a meter is 1,650,763.73 wavelengths of the orange-red light of the element krypton.) The meter is about 39.37 in., that is, about $3\frac{1}{2}$ in. longer than a yard.



Peanuts: © United Features Syndicate, Inc.

A > Converting Metric Units of Length

The number 10 is very important in the metric system, because each unit of length in the system is 10 times longer or 10 times shorter than the next measuring unit. The following table shows the relationship between some metric units of length. You should memorize these names and abbreviations.

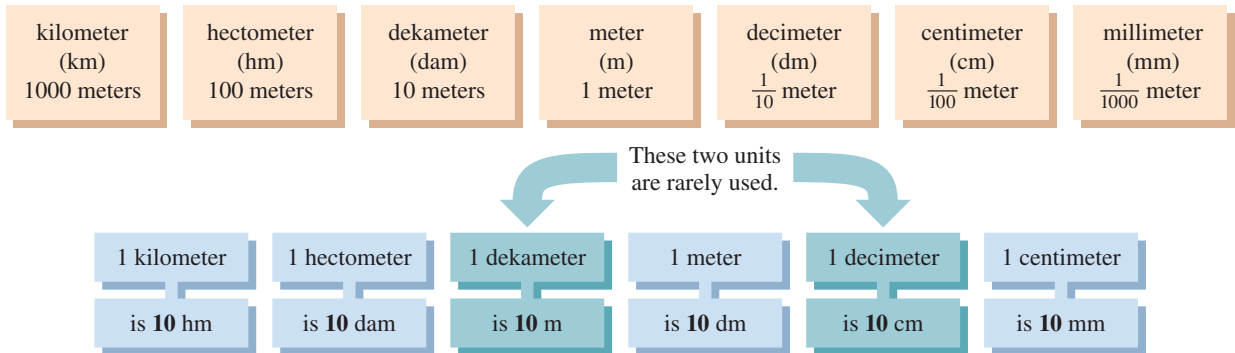

How would the metric system relate to you? When stating the distance between two cities, for example, you now use miles. In the metric system you would use kilometers. Smaller linear dimensions, such as tool sizes, would be measured in centimeters or millimeters. As in the American system, measurements in the metric system involve a **number** (whole, fraction, or decimal) and a **unit**. The ruler shows one of the units used in the metric system: the centimeter. For comparison purposes, 1 inch = 2.54 centimeters.



As before, to change from one unit to another, we simply substitute the correct equivalence. For example, to find out how many meters there are in 2 km, that is, to find $2 \text{ km} = \underline{\hspace{2cm}} \text{ m}$, we proceed as follows:

$$2 \text{ km} = 2 \cdot 1000 \text{ m} = 2000 \text{ m}$$

We can do the problem using unit fractions. Since there are 1000 m in 1 km,

$$1 = \frac{1000 \text{ m}}{\text{km}}$$

so

$$2 \text{ km} = 2 \text{ km} \cdot 1 = 2 \text{ km} \cdot \frac{1000 \text{ m}}{\text{km}} = 2000 \text{ m}$$

As before, we shall work the examples using the substitution and the unit fraction methods.

EXAMPLE 1 Converting kilometers to meters

$$3 \text{ km} = \underline{\hspace{2cm}} \text{ m}$$

SOLUTION 1

Method 1. $3 \text{ km} = 3 \cdot 1000 \text{ m} = 3000 \text{ m}$

Thus, 3 kilometers = 3000 meters.

Method 2. $3 \text{ km} = 3 \text{ km} \cdot 1 = 3 \text{ km} \cdot \frac{1000 \text{ m}}{\text{km}} = 3000 \text{ m}$

PROBLEM 1

$$4 \text{ km} = \underline{\hspace{2cm}} \text{ m}$$

Answers to PROBLEMS

1. 4000 m

To convert from a smaller unit to a larger unit in the metric system, we use the following table:

$$\begin{aligned} 1 \text{ m} &= \frac{1}{1000} \text{ km} \\ 1 \text{ m} &= \frac{1}{100} \text{ hm} \\ 1 \text{ m} &= \frac{1}{10} \text{ dam} \end{aligned}$$

Now we can convert meters to kilometers. For example, to find out how many kilometers there are in 3254 meters, we have to solve

$$3254 \text{ m} = \underline{\hspace{2cm}} \text{ km}$$

Method 1. $3254 \text{ m} = 3254 \cdot \left(\frac{1}{1000} \text{ km}\right)$
 $= \frac{3254}{1000} \text{ km} = 3.254 \text{ km}$

Thus, 3254 meters = 3.254 kilometers.

Remember that to divide by 1000, we simply move the decimal point three places to the left. Thus

$$\frac{3254}{1000} = 3.254$$

Method 2. Since

$$\begin{aligned} 1 &= \frac{\text{km}}{1000 \text{ m}} \\ 3254 \text{ m} &= 3254 \text{ m} \cdot 1 = 3254 \text{ m} \cdot \frac{\text{km}}{1000 \text{ m}} \\ &= 3.254 \text{ km} \end{aligned}$$

EXAMPLE 2 Converting meters to dekameters

$$2 \text{ m} = \underline{\hspace{2cm}} \text{ dam}$$

SOLUTION 2

Method 1. $2 \text{ m} = 2 \cdot \frac{1}{10} \text{ dam}$
 $= \frac{2}{10} \text{ dam} = 0.2 \text{ dam}$

Thus, 2 meters = 0.2 dekameters.

Method 2. $2 \text{ m} = 2 \text{ m} \cdot 1 = 2 \text{ m} \cdot \frac{\text{dam}}{10 \text{ m}} = \frac{2}{10} \text{ dam} = 0.2 \text{ dam}$

PROBLEM 2

$$3 \text{ m} = \underline{\hspace{2cm}} \text{ dam}$$

EXAMPLE 3 Converting dekameters to meters

$$340 \text{ dam} = \underline{\hspace{2cm}} \text{ m}$$

SOLUTION 3

Method 1. $340 \text{ dam} = 340 \cdot 10 \text{ m} = 3400 \text{ m}$

Thus, 340 dekameters = 3400 meters.

Method 2. $340 \text{ dam} = 340 \text{ dam} \cdot 1 = 340 \text{ dam} \cdot \frac{10 \text{ m}}{\text{dam}} = 3400 \text{ m}$

PROBLEM 3

$$4 \text{ dam} = \underline{\hspace{2cm}} \text{ m}$$

Answers to PROBLEMS

2. 0.3 dam 3. 40 m

EXAMPLE 4 Converting meters to centimeters

83.5 m = _____ cm

SOLUTION 4

Method 1. $83.5 \text{ m} = 83.5 \cdot \overbrace{100 \text{ cm}} = 8350 \text{ cm}$

Thus, 83.5 meters = 8350 centimeters.

Method 2. $83.5 \text{ m} = 83.5 \text{ m} \cdot 1 = 83.5 \text{ m} \cdot \frac{100 \text{ cm}}{\cancel{\text{m}}} = 8350 \text{ cm}$

PROBLEM 4

215 m = _____ cm

EXAMPLE 5 Converting centimeters to meters

397 cm = _____ m

SOLUTION 5

Method 1. $397 \text{ cm} = 397 \cdot \overbrace{\frac{1}{100} \text{ m}} = 3.97 \text{ m}$

Thus, 397 centimeters = 3.97 meters.

Method 2. $397 \text{ cm} = 397 \text{ cm} \cdot 1 = 397 \text{ cm} \cdot \frac{\text{m}}{100 \cancel{\text{cm}}} = 3.97 \text{ m}$

PROBLEM 5

581 cm = _____ m

GREEN MATH

EXAMPLE 6 Global warming and sea level

In the last 100 years the Earth’s temperature has increased about one-half a degree Celsius and the sea level has risen 15 to 20 centimeters. Change 15 centimeters to meters.

SOLUTION 6

Method 1. $15 \text{ cm} = 15 \cdot \frac{1}{100} \text{ m} = 0.15 \text{ m}$

Thus, 15 cm = 0.15 m.

Method 2. $15 \text{ cm} = 15 \text{ cm} \cdot 1 = 15 \text{ cm} \cdot \frac{\text{m}}{100 \cancel{\text{cm}}} = 0.15 \text{ m}$

Source: <http://tinyurl.com/krxzsl>.

PROBLEM 6

Change 20 centimeters to meters.

After all these examples you probably have noticed that changing from one unit to another in the metric system can be done simply by moving the decimal point. Thus, if we keep the following table in mind, we can do these conversions mentally.

km	hm	dam	m	dm	cm	mm
1000 m	100 m	10 m	1 m	$\frac{1}{10} \text{ m}$	$\frac{1}{100} \text{ m}$	$\frac{1}{1000} \text{ m}$

Thus, to solve 315 cm = _____ km, we think, “To go from centimeters to kilometers in the table, we must move five places left.” So we move the decimal point five places to the *left*, like this:

$315 \text{ cm} = \overbrace{.00315} \text{ km} = 0.00315 \text{ km}$

Answers to PROBLEMS

4. 21,500 cm 5. 5.81 m

6. 0.20 meters

Similarly, to solve $58.2 \text{ dam} = \underline{\hspace{2cm}} \text{ mm}$, we notice that to go from dekameters to millimeters, we must move four places to the *right*. Thus,

$$58.2 \text{ dam} = 58 \overset{2000}{\text{mm}} = 582,000 \text{ mm}$$

If you need practice on this, you can go back and rework all the examples using this method.

Exercises 7.2



> Practice Problems > Self-Tests
> Media-rich eBooks > e-Professors > Videos

< A > Converting Metric Units of Length In Problems 1–20, use the table to fill in the blank.

km	hm	dam	m	dm	cm	mm
1000 m	100 m	10 m	1 m	$\frac{1}{10}$ m	$\frac{1}{100}$ m	$\frac{1}{1000}$ m

- | | | | |
|----------------------|-----------------------|-----------------------|-----------------------|
| 1. 5 km = _____ m | 2. 4.2 km = _____ m | 3. 1877 m = _____ km | 4. 157 m = _____ km |
| 5. 4 dm = _____ m | 6. 8 dm = _____ m | 7. 49 m = _____ dm | 8. 1.6 m = _____ dm |
| 9. 182 cm = _____ m | 10. 43 cm = _____ m | 11. 22 m = _____ cm | 12. 4.5 m = _____ cm |
| 13. 3 m = _____ mm | 14. 0.35 m = _____ mm | 15. 2358 mm = _____ m | 16. 425 mm = _____ cm |
| 17. 30 cm = _____ mm | 18. 2.4 cm = _____ mm | 19. 67 mm = _____ cm | 20. 184 mm = _____ cm |

Applications

In Problems 21–25, select the answer that is most nearly correct.

- | | |
|---|--|
| <p>21. Height of a basketball player The height of a professional basketball player is:</p> <p>a. 200 mm. b. 200 m. c. 200 cm.</p> | <p>22. Living room dimensions The dimensions of the living room in an ordinary home are:</p> <p>a. 4 m by 5 m. b. 4 cm by 5 cm. c. 4 mm by 5 mm.</p> |
| <p>23. Diameter of aspirin The diameter of an aspirin tablet is:</p> <p>a. 1 cm. b. 1 mm. c. 1 m.</p> | <p>24. Length of 100-yd dash The length of the 100-yd dash is about:</p> <p>a. 100 cm. b. 100 mm. c. 100 m.</p> |
| <p>25. Length of a pencil The length of an ordinary lead pencil is:</p> <p>a. 19 mm. b. 19 cm. c. 19 m.</p> | <p>26. Bed length A bed is 210 cm long. How many meters is that?</p> |
| <p>27. Diameter of a tablet The diameter of a vitamin C tablet is 6 mm. How many centimeters is that?</p> | <p>28. Race length The length of a certain race is 1.5 km. How many meters is that?</p> |
| <p>29. Swimming pool depth The depth of a swimming pool is 1.6 m. How many centimeters is that?</p> | <p>30. Noah's ark Dr. James Strange of the University of South Florida wishes to explore Mount Ararat in Turkey, searching for Noah's ark. According to the book of Genesis, the dimensions of the ark are as follows: length, 300 cubits; breadth, 50 cubits; height, 30 cubits. If a cubit is 52.5 cm, give each dimension in meters.</p> |

- 31. Stride length** The average stride (step) of a runner is about 1 meter in length. If a runner has entered the 5 km (usually written as the 5K) race, how many steps does the runner take to complete the race?
- 32. Length of a race** A runner took 10,000 steps to complete a race. If the average stride (step) for the runner was about 1 meter in length, how long was the race?
- 33. Height of animals** Here are the average heights of three animals in Sedgwick County zoo, Wichita, Kansas:
- 1.1 meters, 3.2 meters and 1.5 meters. Write the heights in cm.
 - The animals are an African elephant, a chimp and a zebra. What is the height of each in centimeters?

Applications: Green Math

Ice covering in Antarctica

- 34.** Antarctica is covered with ice an average of 2133 meters thick. Change 2133 meters to kilometers.
Source: <http://tinyurl.com/krxzsl>.
- 35.** If all of the Antarctic ice melted, sea levels around the world would rise about 61 meters. Change 61 meters to centimeters.

Using Your Knowledge

- 36. Human Bones** The *humerus* is the bone in a person's upper arm. With this bone as a clue, an anthropologist can tell about how tall a person was. If the bone is that of a female, then the height of the person is about

$$(2.75 \times \text{humerus length}) + 71.48 \text{ cm}$$

Suppose the humerus of a female was found to be 31 cm long. About how tall was the person in centimeters?

In Problem 37, match each item in the first column with an appropriate measure in the second column.

- | | |
|---|----------------------------------|
| 37. i. A letter-sized sheet of paper | a. 20 mm \times 25 mm |
| ii. A newspaper | b. 54 mm \times 86 mm |
| iii. A credit card | c. 70 mm \times 150 mm |
| iv. A regular bank check | d. 21.5 cm \times 28 cm |
| v. A postage stamp | e. 35 cm \times 56 cm |

Write On

- 38.** Explain in your own words why it is easier to change from one unit to another in the metric system than it is in the U.S. system.
- 39.** Name three different metric units of length you have seen in your daily life and what they were measuring.

Concept Checker

Fill in the blank(s) with the correct word(s), phrase, or mathematical statement.

- 40.** Measurements in the **metric system** involve a _____ and a _____.

variable

abbreviation

- 41.** To **change** from **one unit to another** simply _____ the correct equivalency.

substitute

prefix

number

unit

>>> Mastery Test

In Problems 42–47, fill in the blank.

42. 457 cm = _____ m

43. 92.4 m = _____ cm

44. 380 dam = _____ m

45. 3 m = _____ dam

46. 9 km = _____ m

47. 2300 m = _____ km

>>> Skill Checker

In Problems 48–53, find the product.

48. $60 \cdot 2.54$

49. $72 \cdot 2.54$

50. $100 \cdot 0.914$

51. $50 \cdot 1.6$

52. $70 \cdot 0.62$

53. $10 \cdot 0.4$

7.3

Length: U.S. to Metric and Metric to U.S. Conversions

▶ Objectives

You should be able to:

- A >** Convert a U.S. (American) unit of length to a metric unit of length and vice versa.
- B >** Solve applications involving changing units from U.S. (American) to metric and vice versa.

▶ To Succeed, Review How To . . .

1. Multiply and divide decimals. (pp. 222–226)
2. Perform basic operations with fractions and decimals. (pp. 135–141, 157–163, 212–217, 222–226)

▶ Getting Started

Metric Sayings What do you think would happen if the United States adopted the metric system right this minute? Many people believe that they would have to be making conversions from American to metric and from metric to American constantly. This is just not true! For example, you probably buy soda or spring water in one- and two-liter bottles, but this does not require that you convert liters to quarts. You may have a foreign car that is totally metric, but you do not need to convert tire or engine sizes to the American system. However, if you insist on converting, here are a few sayings you may want to convert to the metric system:

1. A miss is as good as _____ km.
(a mile)
2. I wouldn't touch it with a _____ m pole.
(10-foot)
3. He was so stubborn he wouldn't give _____ cm.
(an inch)
4. Walk _____ km in my moccasins.
(a mile)

How would you do that? We give you a table of conversions next, so you know!

A > Converting between U.S. System and Metric System

Here is the table you need to convert length measurements between the U.S. system and the metric system and vice versa.

U.S. System to Metric Conversions

1 in. = 2.54 cm*	1 cm = 0.4 in.
1 yd = 0.914 m	1 m = 1.1 yd
1 mi = 1.6 km	1 km = 0.62 mi

To make the conversions, you can use the same methods that we discussed in Sections 7.1 and 7.2.

EXAMPLE 1 Converting feet to centimeters

$$5 \text{ ft} = \underline{\hspace{2cm}} \text{ cm}$$

SOLUTION 1 Remember, $1 \text{ ft} = 12 \text{ in.}$

Method 1. $5 \text{ ft} = 60 \text{ in.} = 60 \cdot 2.54 \text{ cm} = 152.4 \text{ cm}$

Method 2. $5 \text{ ft} = 60 \text{ in.} = 60 \text{ in.} \cdot 1 = 60 \cancel{\text{in.}} \cdot \frac{2.54 \text{ cm}}{\cancel{\text{in.}}} = 152.4 \text{ cm}$

Thus, $5 \text{ ft} = 152.4 \text{ cm}$.

PROBLEM 1

$$7 \text{ ft} = \underline{\hspace{2cm}} \text{ cm}$$

EXAMPLE 2 Converting yards to meters

$$200 \text{ yd} = \underline{\hspace{2cm}} \text{ m}$$

SOLUTION 2 From the table, $1 \text{ yd} = 0.914 \text{ m}$

Method 1. $200 \text{ yd} = 200 \text{ yd} = 200 \cdot 0.914 \text{ m} = 182.8 \text{ m}$

Method 2. $200 \text{ yd} = 200 \text{ yd} = 200 \text{ yd} \cdot 1 = 200 \cancel{\text{yd}} \cdot \frac{0.914 \text{ m}}{\cancel{\text{yd}}} = 182.8 \text{ m}$

Thus, $200 \text{ yd} = 182.8 \text{ m}$.

PROBLEM 2

$$300 \text{ yd} = \underline{\hspace{2cm}} \text{ m}$$

EXAMPLE 3 Converting miles to kilometers

$$60 \text{ mi} = \underline{\hspace{2cm}} \text{ km}$$

SOLUTION 3 From the table, $1 \text{ mi} = 1.6 \text{ km}$

Method 1. $60 \text{ mi} = 60 \text{ mi} = 60 \cdot 1.6 \text{ km} = 96 \text{ km}$

Method 2. $60 \text{ mi} = 60 \text{ mi} = 60 \text{ mi} \cdot 1 = 60 \cancel{\text{mi}} \cdot \frac{1.6 \text{ km}}{\cancel{\text{mi}}} = 96 \text{ km}$

Thus, $60 \text{ mi} = 96 \text{ km}$.

PROBLEM 3

$$70 \text{ mi} = \underline{\hspace{2cm}} \text{ km}$$

EXAMPLE 4 Converting centimeters to inches

$$300 \text{ cm} = \underline{\hspace{2cm}} \text{ in.}$$

SOLUTION 4 From the table, $1 \text{ cm} = 0.4 \text{ in.}$

Method 1. $300 \text{ cm} = 300 \text{ cm} = 300 \cdot 0.4 \text{ in.} = 120 \text{ in.}$

Method 2. $300 \text{ cm} = 300 \text{ cm} = 300 \text{ cm} \cdot 1 = 300 \cancel{\text{cm}} \cdot \frac{0.4 \text{ in.}}{\cancel{\text{cm}}} = 120 \text{ in.}$

Thus, $300 \text{ cm} = 120 \text{ in.}$

PROBLEM 4

$$200 \text{ cm} = \underline{\hspace{2cm}} \text{ in.}$$

Answers to PROBLEMS

1. 213.36 cm 2. 274.2 m
3. 112 km 4. 80 in.

*The inch is defined as exactly 2.54 cm. The other measurements are approximate.

EXAMPLE 5 Converting meters to yards

200 m = _____ yd

SOLUTION 5 From the table, $1 \text{ m} = 1.1 \text{ yd}$ **Method 1.** $200 \text{ m} = 200 \text{ m} = 200 \cdot 1.1 \text{ yd} = 220 \text{ yd}$ **Method 2.** $200 \text{ m} = 200 \text{ m} = 200 \text{ m} \cdot 1 = 200 \cancel{\text{m}} \cdot \frac{1.1 \text{ yd}}{\cancel{\text{m}}} = 220 \text{ yd}$
Thus, $200 \text{ m} = 220 \text{ yd}$.**PROBLEM 5**

300 m = _____ yd

EXAMPLE 6 Converting kilometers to miles

90 km = _____ mi

SOLUTION 6 From the table, $1 \text{ km} = 0.62 \text{ mi}$ **Method 1.** $90 \text{ km} = 90 \text{ km} = 90 \cdot 0.62 \text{ mi} = 55.8 \text{ mi}$ **Method 2.** $90 \text{ km} = 90 \text{ km} = 90 \text{ km} \cdot 1 = 90 \cancel{\text{km}} \cdot \frac{0.62 \text{ mi}}{\cancel{\text{km}}} = 55.8 \text{ mi}$
Thus, $90 \text{ km} = 55.8 \text{ mi}$.**PROBLEM 6**

70 km = _____ mi

Before you go on to the applications, remember your estimation:

Inches are longer than centimeters, so when you convert inches to centimeters, the answer should be **larger** than the given number. Yards are shorter than meters, so when you convert yards to meters, the answer should be **smaller** than the given number. Miles are longer than kilometers, so when you convert miles to kilometers, the answer should be **larger** than the given number.

B > Applications Involving U.S. and Metric Units of Length

EXAMPLE 7 Converting feet to centimeters

A man is 6 ft tall. How many centimeters is that?

SOLUTION 7 $1 \text{ ft} = 12 \text{ in.}$ **Method 1.** $6 \text{ ft} = 72 \text{ in.} = 72 \cdot 2.54 \text{ cm} = 182.88 \text{ cm}$ **Method 2.** $6 \text{ ft} = 72 \text{ in.} = 72 \text{ in.} \cdot 1 = 72 \cancel{\text{in.}} \cdot \frac{2.54 \text{ cm}}{\cancel{\text{in.}}} = 182.88 \text{ cm}$ **PROBLEM 7**

A woman is 5 feet tall. How many centimeters is that?

EXAMPLE 8 Converting yards to meters

A football field is 100 yd long. How many meters is that?

SOLUTION 8**Method 1.** $100 \text{ yd} = 100 \cdot 0.914 \text{ m} = 91.4 \text{ m}$ **Method 2.** $100 \text{ yd} = 100 \text{ yd} \cdot 1 = 100 \cancel{\text{yd}} \cdot \frac{0.914 \text{ m}}{\cancel{\text{yd}}} = 91.4 \text{ m}$ **PROBLEM 8**

A pool is 50 yards long. How many meters is that?

EXAMPLE 9 Converting miles to kilometers

A car is traveling at 50 mi/hr. How many kilometers per hour is that?

SOLUTION 9**Method 1.** $50 \text{ mi} = 50 \cdot 1.6 \text{ km} = 80 \text{ km}$ **Method 2.** $50 \text{ mi} = 50 \text{ mi} \cdot 1 = 50 \cancel{\text{mi}} \cdot \frac{1.6 \text{ km}}{\cancel{\text{mi}}} = 80 \text{ km}$
Thus 50 mi/hr is equivalent to 80 km/hr.**PROBLEM 9**

A car is traveling at 30 miles per hour. How many kilometers per hour is that?

Answers to PROBLEMS

5. 330 yd 6. 43.4 mi 7. 152.40 8. 45.7 9. 48

EXAMPLE 10 Converting meters to yards

An Olympic pool is 100 m long. How many yards is that?

SOLUTION 10

Method 1. $100 \text{ m} = 100 \cdot \overbrace{1.1 \text{ yd}}^{\text{m}} = 110 \text{ yd}$

Method 2. $100 \text{ m} = 100 \text{ m} \cdot 1 = 100 \cancel{\text{m}} \cdot \frac{1.1 \text{ yd}}{\cancel{\text{m}}} = 110 \text{ yd}$

PROBLEM 10

A track race in the Olympics is the 200-meter event. How many yards is that?

EXAMPLE 11 Converting kilometers to miles

A car is traveling at 70 km/hr. How many miles per hour is that?

SOLUTION 11

Method 1. $70 \text{ km} = 70 \cdot \overbrace{0.62 \text{ mi}}^{\text{km}} = 43.40 \text{ mi}$

Method 2. $70 \text{ km} = 70 \text{ km} \cdot 1 = 70 \cancel{\text{km}} \cdot \frac{0.62 \text{ mi}}{\cancel{\text{km}}} = 43.40 \text{ mi}$

Thus, the car is traveling at 43.40 mi/hr.

PROBLEM 11

A car is traveling 80 kilometers per hour. How many miles per hour is that?

GREEN MATH

EXAMPLE 12 Glacier melting

Glaciers in the European Alps lost 275 centimeters in ice thickness. How many inches is that?

SOLUTION 12

Method 1. $275 \text{ cm} = 275 \cdot \overbrace{0.4 \text{ in.}}^{\text{cm}} = 110 \text{ in.}$

Method 2. $275 \text{ cm} = 275 \cdot 1 = 275 \cancel{\text{cm}} \cdot \frac{0.4 \text{ in.}}{\cancel{\text{cm}}} = 110 \text{ in.}$

Source: <http://tinyurl.com/dfwlvj>.

PROBLEM 12

Maritime glaciers in Scandinavia gained more than 100 cm in thickness. How many inches is that?

> Exercises 7.3



> Practice Problems > Self-Tests
> Media-rich eBooks > e-Professors > Videos

< A > Converting between U.S. System and Metric System In Problems 1–12, fill in the blanks.

- | | | |
|----------------------|----------------------|-----------------------|
| 1. 4 ft = _____ cm | 2. 3 ft = _____ cm | 3. 30 yd = _____ m |
| 4. 20 yd = _____ m | 5. 90 mi = _____ km | 6. 100 mi = _____ km |
| 7. 20 cm = _____ in. | 8. 50 cm = _____ in. | 9. 600 m = _____ yd |
| 10. 500 m = _____ yd | 11. 10 km = _____ mi | 12. 400 km = _____ mi |

Answers to PROBLEMS

10. 220 11. 49.60 12. 40 in.

< B > Applications Involving U.S. and Metric Units of Length

- 13. Football** Steve O'Neal of the New York Jets kicked a 98-yd punt on September 21, 1969. How many meters is that? (Give answer to one decimal place.)
- 15. Mount Everest** Mount Everest is 8848 m high. How many yards is that? (Give answer to the nearest hundred.)
- 17. Speed limit in Europe** The speed limit on European highways is 100 km/hr. How many miles per hour is that?
- 19. Miss World contest** In a Miss World contest the winner had measurements of 90-60-90 (in centimeters). What is that in inches?
- 21. Venice** The city of Venice is built on wooden planks that are sinking at the rate of seven centimeters per century. How many inches per century is that?
- 23. Shanghai** Parts of Shanghai are now sinking at a rate of 1 inch a year, largely as a result of a massive building boom there over the last 10 years. How many centimeters per year is that?
- 14. Largest swimming pool** The largest swimming pool in Casablanca, Morocco, is 82 yd wide. How many meters is that? (Give answer to one decimal place.)
- 16. Speed limit** The speed limit on a highway is 55 mi/hr. How many kilometers per hour is that?
- 18. Author's dimensions** The author of this book once had measurements of 46-30-36 (in inches). How would you write that in centimeters? (Use 1 in. = 2.5 cm.)
- 20. TV screen dimensions** The screen of a TV set measures 24 in. diagonally. How many centimeters is that?
- 22. Venice** A recent study by an American group, however, estimated that Venice sank a whopping 24 centimeters in the last century alone! How many inches is that?
Source: <http://www.classbrain.com>.
- 24. Louisiana** The sinking in Louisiana has run anywhere from 6 to 20 inches over the past 20 years, according to Roy Dokka, a professor at Louisiana State University's Center for Geoinformatics. How much has Louisiana been sinking in centimeters over the last 20 years?

>>> Applications: Green Math*Ice melt and sea levels*

- 25.** If all of the Antarctic ice melted, **sea levels** around the world would rise about 61 meters. Convert 61 meters to yards. If you live near the coast, don't worry too much about this, the temperature in Antarctica is -37°C , so the ice there is in no danger of melting.
- 27.** The Intergovernmental Panel on Climate Change (IPCC) estimates that the sea will rise 50 centimeters by the year 2100. Change 50 centimeters to inches.
- 29.** Scientists project rising sea levels to continue through the twenty-first century, with levels increasing between 7 and 22 inches by 2100. Convert 7 inches and 22 inches to centimeters.
- 26.** There is a significant amount of ice covering Greenland, which would add another 7 meters to the oceans if it melted. Change 7 meters to yards.
- 28.** In the twentieth century, sea levels only rose 17 centimeters. Change 17 centimeters to inches.
- 30.** The IPCC estimates that the sea will rise 20 inches by the year 2100. Convert 20 inches to centimeters.
Source: <http://www.howstuffworks.com/question473.htm>.

Speeding glaciers

- 31.** The fastest glacier in Greenland doubled its speed between 1997 and 2003. In 1997, it was moving at a leisurely 6.7 km per year. To three decimal places, how many miles per year is that?
- 33.** The Greenland glacier was moving 3.54 miles per year in 1992. To three decimal places, how many kilometers per year is that?
- 32.** In the spring of 2003, the Greenland glacier sped up to 12.6 km per year. To three decimal places, how many miles per year is that?
- 34.** The glacier sped up to 7.83 miles per year in 2003. To three decimal places, how many kilometers per year is that?
Source: <http://www.sciencedaily.com/releases/2004/12/041203085918.htm>.

7.4

Area: U.S., Metric, and Conversions

▶ Objectives

You should be able to:

- A > Convert from one metric unit of area to another.
- B > Convert from one U.S. unit of area to another.
- C > Convert units of area from metric to U.S. (American) and vice versa.
- D > Solve applications involving U.S. and metric units of area.

▶ To Succeed, Review How To . . .

1. Multiply a whole number by a fraction. (p. 137)
2. Multiply and divide decimals. (pp. 222–226)

▶ Getting Started

Suppose there was a parade and *everybody* came. How can you estimate the crowd? Robert Gillette, a reporter for the *Los Angeles Times*, estimates attendance at the Tournament of Roses Parade by using areas. First, he measures the depth of the standing room area at 23 ft. (This depth is bounded by the blue line behind which spectators must stand and by the buildings at the back of the crowd.) Then he multiplies by the 5.5-mi parade route and doubles the amount, since there are spectators on both sides of the street. So far, the calculation is

$$23 \text{ ft} \cdot 5.5 \text{ mi} \cdot 2$$

Unfortunately, the answer is in feet \times miles. We can convert this to square feet if we remember that 1 mi = 5280 ft. Substituting,

$$\begin{aligned} 23 \text{ ft} \cdot 5.5 \text{ mi} \cdot 2 &= 23 \text{ ft} \cdot 5.5 \cdot 5280 \text{ ft} \cdot 2 \\ &= 1,335,840 \text{ ft}^2 \end{aligned}$$

That is, an area of 1,335,840 ft² is available along the parade route. Mr. Gillette finishes his calculations by assuming that each spectator occupies 2 ft² (2 ft thick and 1 ft wide). Dividing 2 ft² into 1,335,840 ft² gives the estimated attendance as

$$\frac{1,335,840 \text{ ft}^2}{2 \text{ ft}^2} = 667,920 \text{ persons}$$



A > Converting from One Metric Unit of Area to Another

Sometimes we wish to convert one metric unit of area to another. To do this we substitute the correct equivalent unit as shown in Examples 1 and 2.

EXAMPLE 1 Converting square meters to square centimeters

$$1 \text{ m}^2 = \underline{\hspace{2cm}} \text{ cm}^2$$

SOLUTION 1 We proceed as follows:

$$1 \text{ m}^2 = 1 \cdot (100 \text{ cm})^2 = 1 \cdot (100 \text{ cm}) \cdot (100 \text{ cm}) = 10,000 \text{ cm}^2$$

PROBLEM 1

$$5 \text{ m}^2 = \underline{\hspace{2cm}} \text{ cm}^2$$

EXAMPLE 2 Converting square kilometers to square meters

$$1 \text{ km}^2 = \underline{\hspace{2cm}} \text{ m}^2$$

SOLUTION 2

$$1 \text{ km}^2 = 1 \cdot (1000 \text{ m})^2 = 1 \cdot (1000 \text{ m}) \cdot (1000 \text{ m}) = 1,000,000 \text{ m}^2$$

PROBLEM 2

$$2 \text{ km}^2 = \underline{\hspace{2cm}} \text{ m}^2$$

B > Converting from One U.S. Unit of Area to Another

A similar procedure can be used when changing units in the customary U.S. system.

EXAMPLE 3 Converting square feet to square inches

$$1 \text{ ft}^2 = \underline{\hspace{2cm}} \text{ in.}^2$$

SOLUTION 3 Substituting,

$$1 \text{ ft}^2 = 1 \cdot (12 \text{ in.})^2 = 144 \text{ in.}^2$$

PROBLEM 3

$$5 \text{ ft}^2 = \underline{\hspace{2cm}} \text{ in.}^2$$

When converting from smaller to larger units in the U.S. customary system, it is advantageous to remember the following facts. Since $12 \text{ in.} = 1 \text{ ft}$, $1 \text{ in.} = \frac{1}{12} \text{ ft}$. Thus, $(1 \text{ in.})^2 = (\frac{1}{12} \text{ ft})^2 = (\frac{1}{12} \text{ ft}) \cdot (\frac{1}{12} \text{ ft}) = \frac{1}{144} \text{ ft}^2$. That is,

$$1 \text{ in.}^2 = \frac{1}{144} \text{ ft}^2$$

Similarly, $3 \text{ ft} = 1 \text{ yd}$ and $1 \text{ ft} = \frac{1}{3} \text{ yd}$. Thus,

$$(1 \text{ ft})^2 = \left(\frac{1}{3} \text{ yd}\right)^2 = \left(\frac{1}{3} \text{ yd}\right) \cdot \left(\frac{1}{3} \text{ yd}\right) = \frac{1}{9} \text{ yd}^2$$

That is,

$$1 \text{ ft}^2 = \frac{1}{9} \text{ yd}^2$$

We summarize these two facts in the table.

$1 \text{ in.}^2 = \frac{1}{144} \text{ ft}^2$ $1 \text{ ft}^2 = \frac{1}{9} \text{ yd}^2$
--

EXAMPLE 4 Converting square inches to square feet

$$288 \text{ in.}^2 = \underline{\hspace{2cm}} \text{ ft}^2$$

SOLUTION 4 Substituting,

$$288 \text{ in.}^2 = 288 \cdot \left(\frac{1}{144} \text{ ft}^2\right) = 288 \cdot \frac{1}{144} \text{ ft}^2 = 2 \text{ ft}^2$$

PROBLEM 4

$$432 \text{ in.}^2 = \underline{\hspace{2cm}} \text{ ft}^2$$

Answers to PROBLEMS

- | | |
|---------------------------|-----------------------------|
| 1. 50,000 cm ² | 2. 2,000,000 m ² |
| 3. 720 in. ² | 4. 3 ft ² |

EXAMPLE 5 Converting square feet to square yards

$$27 \text{ ft}^2 = \text{_____} \text{ yd}^2$$

SOLUTION 5

$$27 \text{ ft}^2 = 27 \cdot \frac{1}{9} \text{ yd}^2 = 3 \text{ yd}^2$$

PROBLEM 5

$$36 \text{ ft}^2 = \text{_____} \text{ yd}^2$$

In the U.S. (American) system, large areas are measured in **acres**. An acre is 4840 yd², that is,

$$1 \text{ acre} = 4840 \text{ yd}^2$$

EXAMPLE 6 Converting acres to square yards

What is the area in square yards of a 5-acre lot?

SOLUTION 6 We know that

$$1 \text{ acre} = 4840 \text{ yd}^2$$

Thus, $5 \text{ acres} = 5 \cdot 4840 \text{ yd}^2 = 24,200 \text{ yd}^2$

PROBLEM 6

What is the area in square yards of a 20-acre lot?

C > Converting Units of Area from Metric to U.S. (American) and Vice Versa

When using metric units, we measure large areas in hectares. A **hectare** is the area of a square 100 meters on each side. Thus,

$$1 \text{ hectare} = 10,000 \text{ m}^2$$

EXAMPLE 7 Converting hectares to square meters

$$7 \text{ hectares} = \text{_____} \text{ m}^2$$

SOLUTION 7 We know that

$$1 \text{ hectare} = 10,000 \text{ m}^2$$

Thus, $7 \text{ hectares} = 7 \cdot 10,000 \text{ m}^2 = 70,000 \text{ m}^2$

PROBLEM 7

$$12 \text{ hectares} = \text{_____} \text{ m}^2$$

The relationship between hectares and acres is as follows:

$$1 \text{ hectare} = 2.47 \text{ acres}$$

EXAMPLE 8 Converting hectares to acres

$$2 \text{ hectares} = \text{_____} \text{ acres}$$

SOLUTION 8 Since

$$1 \text{ hectare} = 2.47 \text{ acres}$$

$$2 \text{ hectares} = 2 \cdot 2.47 \text{ acres} = 4.94 \text{ acres}$$

PROBLEM 8

$$6 \text{ hectares} = \text{_____} \text{ acres}$$

Answers to PROBLEMS

5. 4 yd² 6. 96,800 yd²

7. 120,000 m² 8. 14.82 acres

D > Applications Involving U.S. and Metric Units of Area

GREEN MATH

EXAMPLE 9 Disappearing lakes

Sometime in May 2007, a glacial lake in southern **Chile** actually disappeared! Chilean surveyors reported that the lake was its usual size: 100 feet deep and covering an area of about 5 acres. Then it disappeared! The lake's disappearance was blamed on *too much water*, which broke the dam that held its water in place. Convert 5 acres to hectares and give the answer to the nearest hundredth (two decimal places).

Source: <http://science.howstuffworks.com/disappearing-lake.htm>.

SOLUTION 9

Since $1 \text{ hectare} = 2.47 \text{ acres}$
 $1 \text{ acre} = \frac{1 \text{ hectare}}{2.47}$
 and $5 \text{ acres} = 5 \cdot \frac{1 \text{ hectare}}{2.47}$
 $= 2.02 \text{ hectares}$

Thus, the size of the lake was 2.02 hectares.

PROBLEM 9

Several industrial disasters have also made lakes disappear! Louisiana's Lake Peigneur was only 11 feet deep but covered 1300 acres. Then a drilling rig pierced a salt deposit below the lake creating a 1300-foot-deep salt water lake! Convert 1300 acres to hectares.

> Exercises 7.4



> Practice Problems > Self-Tests
 > Media-rich eBooks > e-Professors > Videos

< A > Converting from One Metric Unit of Area to Another

< B > Converting from One U.S. Unit of Area to Another

In Problems 1–10, fill in the blanks.

- | | | | |
|--|--|--|---|
| 1. $3 \text{ km}^2 = \underline{\hspace{2cm}} \text{ m}^2$ | 2. $4 \text{ km}^2 = \underline{\hspace{2cm}} \text{ m}^2$ | 3. $2 \text{ ft}^2 = \underline{\hspace{2cm}} \text{ in.}^2$ | 4. $8 \text{ ft}^2 = \underline{\hspace{2cm}} \text{ in.}^2$ |
| 5. $432 \text{ in.}^2 = \underline{\hspace{2cm}} \text{ ft}^2$ | 6. $720 \text{ in.}^2 = \underline{\hspace{2cm}} \text{ ft}^2$ | 7. $54 \text{ ft}^2 = \underline{\hspace{2cm}} \text{ yd}^2$ | 8. $162 \text{ ft}^2 = \underline{\hspace{2cm}} \text{ yd}^2$ |
| 9. $2 \text{ acres} = \underline{\hspace{2cm}} \text{ yd}^2$ | 10. $3 \text{ acres} = \underline{\hspace{2cm}} \text{ yd}^2$ | | |

< C > Converting Units of Area from Metric to U.S. (American) and Vice Versa

In Problems 11–14, fill in the blanks.

- | | | | |
|---|---|---|---|
| 11. $3 \text{ hectares} = \underline{\hspace{2cm}} \text{ acres}$ | 12. $5 \text{ hectares} = \underline{\hspace{2cm}} \text{ acres}$ | 13. $2 \text{ hectares} = \underline{\hspace{2cm}} \text{ m}^2$ | 14. $5 \text{ hectares} = \underline{\hspace{2cm}} \text{ m}^2$ |
|---|---|---|---|

< D > Applications Involving U.S. and Metric Units of Area

- | | |
|--|--|
| 15. <i>Bookstores</i> One of the largest bookstores is that of Barnes and Noble in New York, with 154,250 ft ² of space. To the nearest square yard, how many square yards is that? | 16. <i>Department stores</i> The world's largest store, R. H. Macy and Co., occupies 46 acres. How many square yards is that? |
| 17. <i>Volkswagen plant</i> The Volkswagen Wolfsburg plant in Germany occupies 1730 acres. How many square yards is that? | 18. <i>Area of Monaco</i> Monaco, on the south coast of France, has an area of 370 acres. How many square yards is that? |
| 19. <i>Area of a house</i> The carpeted area of a house is 50 ft long and 30 ft wide.
a. How many square feet is that?
b. How many square yards of carpet is that? | 20. <i>Area of Vehicle Assembly Building</i> The Vehicle Assembly Building (VAB) near Cape Canaveral has a floor area of 343,500 ft ² . How many acres is that? Answer to the nearest hundredth (two decimal places). |

Answers to PROBLEMS

9. 526.32 hectares

- 21. Convention space** The convention space at the Hilton Hotel in Las Vegas covers 125,000 ft². How many acres is that? Answer to the nearest hundredth (two decimal places).
- 23. Casinos** Circus Circus in Las Vegas covers an area of 129,000 ft². How many acres is that? Answer to the nearest hundredth (two decimal places).

All about *Freedom* (the ship)

- 24. Cruise ships** At the present time, the second biggest cruise ship is the *Freedom of the Seas*, which has more than 100 acres of outdoor park, recreation, exercise, and community space! How many square yards is that? By the way, the *Oasis of the Sea* is the biggest cruise ship now!
- 25. Cruise ships** You can actually buy a 474 m² “residency” on board. How many square feet in your residency? (Hint: 1 m² ≈ 11 ft².) By the way, the cost of the residency was \$9,340,600.

- 22. Area of a recreation deck** The recreation deck in the roof of the Hilton Hotel in Las Vegas covers 10 acres. How many square yards is that?



- 26. Cruise ships** You can have a smaller 125 m² place with a water view for a mere \$1,154,500. How many square feet will you get for your money?

>>> Applications: Green Math

The disappearing glaciers

- 27.** One of the more accessible glaciers in the Canadian Rockies is the Athabasca Glacier, an outlet glacier of the 325 km² Columbia Icefield. Convert 325 km² to square meters.
- 28.** The Peyto Glacier in Alberta, Canada, covers an area of about 12 km² and retreated rapidly during the first half of the twentieth century, stabilized by 1966, and resumed shrinking in 1976. Convert 12 km² to square meters.
- 29.** The Furtwängler Glacier is located near the summit of Kilimanjaro. Between 1976 and 2000, the area of Furtwängler Glacier was cut almost in half, from 113,000 m² to 60,000 m². Why? During fieldwork conducted early in 2006, scientists discovered a large hole near the center of the glacier. Convert 113,000 m² to km².
- 30.** There were 18 glaciers atop Mount Kenya (Africa) in 1900, but by 1986 only 11 remained. The total area covered by glaciers was 1,600,000 m². Convert 1,600,000 m² to km².

Source: http://en.wikipedia.org/wiki/Retreat_of_glaciers_since_1850#Antarctica.

>>> Using Your Knowledge

Area Many practical problems around the house require some knowledge of the material we have studied. For example, let us say your living room is 12 ft by 10 ft. Its area is 12 ft × 10 ft = 120 ft². Since carpets are sold by the square yard, to carpet this area we need to know how many square yards we have. Here is how we do it.

From one of the tables, 1 ft² = $\frac{1}{9}$ yd². Thus,

$$120 \text{ ft}^2 = 120 \cdot \frac{1}{9} \text{ yd}^2 = \frac{120}{9} \text{ yd}^2 = 13\frac{1}{3} \text{ yd}^2$$

Hence, we need 13 $\frac{1}{3}$ square yards of carpet.

- 31.** How many square yards of carpet do we need to carpet a room 12 ft by 11 ft? **32.** How many square yards of carpet do we need to carpet a room 12 ft by 15 ft?

We can use these ideas outdoors, too. Suppose your lawn is 30 yd by 20 yd. Its area is

$$30 \text{ yd} \cdot 20 \text{ yd} = 600 \text{ yd}^2$$

If you wish to plant new grass in this lawn, you can buy sod—squares of grass that can be simply laid on the ground. Each sod square is approximately 1 ft². How many squares do you need? You first convert 600 yd² to square feet. Thus,

$$600 \text{ yd}^2 = 600 \cdot (3 \text{ ft})^2 = 600 \cdot (9 \text{ ft}^2) = 5400 \text{ ft}^2$$

Hence, you need 5400 squares of sod.

33. How many squares of sod do we need to cover a piece of land 50 yd by 20 yd?
34. How many squares of sod do we need to cover a piece of land 40 yd by 15 yd?
35. Wallpaper comes in a roll containing 36 ft² of paper. A wall is 12 ft by 9 ft. How many rolls do we need to paper this wall?

>>> Write On

36. A hectometer is 100 meters. What is a hectare in terms of hectometers?
37. Which is larger and why: A square yard or a square meter?

>>> Mastery Test

In Problems 38–45, fill in the blank.

38. $2 \text{ m}^2 = \underline{\hspace{2cm}} \text{ cm}^2$
39. $54 \text{ ft}^2 = \underline{\hspace{1cm}} \text{ yd}^2$
40. $576 \text{ in.}^2 = \underline{\hspace{1cm}} \text{ ft}^2$
41. $3 \text{ ft}^2 = \underline{\hspace{1cm}} \text{ in.}^2$
42. $5 \text{ km}^2 = \underline{\hspace{2cm}} \text{ m}^2$
43. 4 hectares = $\underline{\hspace{1cm}}$ acres
44. 6 hectares = $\underline{\hspace{1cm}} \text{ m}^2$
45. What is the area in square yards of a 10-acre lot?

>>> Skill Checker

46. Multiply $\frac{1}{2} \cdot 4$
47. Write $\frac{500}{240}$ as a mixed number.
48. Write $\frac{400}{240}$ as a mixed number.

7.5

Volume (Capacity): U.S., Metric, and Conversions

▶ Objectives

You should be able to:

A > Convert units of volume in the U.S. system to metric and vice versa.

B > Convert units of volume from one metric unit to another.

C > Solve applications using U.S. and metric units of volume.

▶ To Succeed, Review How To . . .

1. Divide by powers of 10. (pp. 227–228)
2. Multiply fractions. (pp. 135–138)

▶ Getting Started

The Tropicana pack in the photograph holds 2 quarts, or 1892 milliliters (mL). (A **milliliter** is defined to be the volume of a cube 1 cm on each edge.) In the metric system the basic unit of volume is the **liter**. A **liter** is the volume of a cube 10 cm on each edge. The U.S. customary system uses the **quart** to measure volume. From the Tropicana pack we know that

$$2 \text{ quarts} = 1892 \text{ milliliters}$$

Thus

$$1 \text{ quart} = 946 \text{ milliliters}$$

Since a milliliter is $\frac{1}{1000}$ of a liter,

$$1 \text{ quart} = 0.946 \text{ liter}$$

Thus, a quart is slightly less than a liter.



A > U.S. (American) to Metric Conversion

As usual, the units used to measure volume in the U.S. (American) system are more complicated. Here they are for comparison.

U.S. (American) System	Metric System
8 ounces (oz) = 1 cup (c)	1 liter (L) = 1000 milliliters (mL)
2 cups (c) = 1 pint (pt)	1 cubic centimeter (cm ³) = 1 mL
16 ounces (oz) = 1 pint (pt)	
2 pt = 1 quart (qt) = 32 (oz)	
4 qt = 1 gallon (gal)	
1 qt = 0.946 L	
1 L = 1.06 qt	

To make some conversions from the customary to the metric system, you can capitalize on the fact that 1 qt is approximately equal to 1 L (1 qt \approx 1 L). For example, to solve

$$1 \text{ gal} = \text{_____ L}$$

you can think like this:

$$1 \text{ gal} = 4 \text{ qt}$$

and since 1 qt \approx 1 L, then

$$1 \text{ gal} \approx 4 \text{ L}$$

Note that \approx means “is approximately equal to.”

EXAMPLE 1 Converting U.S. units of volume to metric units

Fill in the blanks.

- a. $\frac{1}{2}$ gal \approx _____ L b. 8 oz \approx _____ L c. 20 gal \approx _____ L

SOLUTION 1

a. Since

$$1 \text{ gal} = 4 \text{ qt}$$

$$\frac{1}{2} \text{ gal} = \frac{1}{2} (4 \text{ qt}) = 2 \text{ qt}$$

$$\text{Thus, } \frac{1}{2} \text{ gal} \approx 2 \text{ L.}$$

c. Since

$$1 \text{ gal} = 4 \text{ qt}$$

$$20 \text{ gal} = 20 (4 \text{ qt}) = 80 \text{ qt} \approx 80 \text{ L}$$

$$\text{Thus, } 20 \text{ gal} \approx 80 \text{ L.}$$

b. Since

$$32 \text{ oz} = 1 \text{ qt}$$

$$\frac{1}{4} (32 \text{ oz}) = \frac{1}{4} \text{ qt} \approx \frac{1}{4} \text{ L}$$

$$\text{Thus, } 8 \text{ oz} \approx \frac{1}{4} \text{ L.}$$

PROBLEM 1

Fill in the blanks.

- a. $\frac{1}{4}$ gal \approx _____ L
 b. 16 oz \approx _____ L
 c. 10 gal \approx _____ L

B > Converting from One Metric Measure to Another

As before, volume conversions in the metric system are just a matter of moving the decimal point. Here is a table to aid in the process.

kiloliter (kL)	hectoliter (hL)	dekaliter (daL)	liter (L)	deciliter (dL)	centiliter (cL)	milliliter (mL)
1000 L	100 L	10 L	1 L	$\frac{1}{10}$ L	$\frac{1}{100}$ L	$\frac{1}{1000}$ L

Answers to PROBLEMS

1. a. 1 L b. $\frac{1}{2}$ L c. 40 L

Thus, to solve $5 \text{ hL} = \underline{\hspace{2cm}} \text{ L}$, we see that to go from hectoliters to liters in the table, we must move *two* places to the right. So we move the decimal point in 5 *two* places to the right, obtaining

$$5 \text{ hL} = 500 \text{ L}$$

That is, $5 \text{ hL} = 500 \text{ L}$.

EXAMPLE 2 Converting kiloliters to liters

$$8 \text{ kL} = \underline{\hspace{2cm}} \text{ L}$$

SOLUTION 2 To go from kiloliters to liters in the table, we must move three places to the right. Thus

$$8 \text{ kL} = 8000 \text{ L}$$

PROBLEM 2

$$9 \text{ kL} = \underline{\hspace{2cm}} \text{ L}$$

EXAMPLE 3 Converting milliliters to liters

$$481 \text{ mL} = \underline{\hspace{2cm}} \text{ L}$$

SOLUTION 3 To go from milliliters to liters in the table, we must move three places to the left. Thus

$$481 \text{ mL} = 0.481 \text{ L}$$

PROBLEM 3

$$247 \text{ mL} = \underline{\hspace{2cm}} \text{ L}$$

C > Applications Involving U.S. and Metric Units of Volume

Capacity can also be measured using the *household method*, a method using common measures such as *teaspoons*, *tablespoons*, *fluid ounces*, and *cups*.

Here are the equivalencies between common capacity measures and metric system measures. By the way, a milliliter (mL) is the capacity of an eyedropper or $\frac{1}{5}$ of a teaspoon.

Household and Metric Measures

$$1 \text{ teaspoon} = 5 \text{ mL}$$

$$1 \text{ fluid oz} = 30 \text{ mL}$$

$$1 \text{ tablespoon} = 15 \text{ mL}$$

$$1 \text{ cup} = 240 \text{ mL}$$

EXAMPLE 4 Converting units for a recipe

Do you want to make your own cleaner? *The Old Farmer's Almanac* gives the following recipe for an oven cleaner:

Oven Cleaner

$$2 \text{ tablespoons dishwashing liquid} \quad \frac{1}{4} \text{ cup ammonia}$$

$$2 \text{ teaspoons borax} \quad 1\frac{1}{2} \text{ cups warm water}$$

- How many milliliters of dishwashing liquid do you need?
- How many milliliters of borax do you need?

(See <http://www.almanac.com/home/cleaners.html>.)

PROBLEM 4

- How many milliliters of ammonia do you need?
- How many milliliters of warm water do you need?

(continued)

Answers to PROBLEMS

2. 9000 L 3. 0.247 L

4. a. 60 mL b. 360 mL

SOLUTION 4

- a. As usual, we use substitution to solve the problem.

We need two tablespoons of dishwashing liquid.

We know that $1 \text{ tablespoon} = 15 \text{ mL}$

Thus, $2 \text{ tablespoons} = 2 \cdot 15 \text{ mL} = 30 \text{ mL}$

This means that we need 30 mL of dishwashing liquid.

- b. We need two teaspoons of borax.

We know that $1 \text{ teaspoon} = 5 \text{ mL}$

Thus, $2 \text{ teaspoons} = 2 \cdot 5 \text{ mL} = 10 \text{ mL}$

This means that we need 10 mL of borax.

EXAMPLE 5 Converting units for a recipe

A recipe for Sopa Azteca calls for 500 mL of cream of tomato soup. How many cups is that?

SOLUTION 5

We know that $240 \text{ mL} = 1 \text{ cup}$ (See table.)

This means that $1 \text{ mL} = \frac{1 \text{ cup}}{240}$

Thus, $500 \text{ mL} = \frac{500 \text{ cup}}{240} = 2\frac{1}{12} \text{ cups}$

This means that we need $2\frac{1}{12}$ cups of tomato soup. Probably two cups will do!

PROBLEM 5

Sopa Azteca also calls for 400 mL of consommé. How many cups is that?

Many medical applications require knowledge of the metric system. For example, most liquids in your local pharmacy are labeled in liters (L) or milliliters (mL). Drug dosages are usually given in milliliters or cubic centimeters (cc) or cm^3 . Here is the relationship between milliliters (mL), cc, and cubic centimeters.

$$1 \text{ mL} = 1 \text{ cm}^3 = 1 \text{ cc}$$

EXAMPLE 6 Unit conversions and medicine

A doctor orders 20 ounces of IV (intravenous) fluid for a patient.

- a. How many mL is that?
b. How many cc is that?

SOLUTION 6

- a. We first have to convert fluid ounces to mL.

We know that $1 \text{ fluid ounce} = 30 \text{ mL}$

Thus, $20 \text{ fluid ounces} = 20 \cdot 30 \text{ mL} = 600 \text{ mL}$

This means that the doctor ordered 600 mL of IV fluid.

- b. Now, we have to convert mL to cc.

We know that $1 \text{ mL} = 1 \text{ cc}$

Thus, $600 \text{ mL} = 600 \cdot 1 \text{ cc} = 600 \text{ cc}$

This means the doctor ordered 600 cc of IV fluid.

PROBLEM 6

A doctor orders 30 fluid ounces of acetaminophen pediatric elixir.

- a. How many mL is that?
b. How many cc is that?

Answers to PROBLEMS

5. $1\frac{2}{3}$ cups

6. a. 900 mL b. 900 cc

GREEN MATH

EXAMPLE 7 Water needed to produce one liter of ethanol

One liter of corn-derived ethanol requires 264 to 784 liters of water to both *grow* the corn and *convert* it into ethanol.

- Convert 264 liters to gallons, assuming that $1 \text{ qt} \approx 1 \text{ L}$.
- If your gas tank holds 13 gallons of gas, and 10% is ethanol, how many gallons is ethanol?
- How many liters are ethanol and how much water was used to *grow* the corn and *convert* it to ethanol?

Source: <http://beta.technologyreview.com/energy/22428/>.

SOLUTION 7

a. $1 \text{ gallon} = 4 \text{ qt} \approx 4 \text{ L}$

Thus, $1 \text{ L} = \frac{1 \text{ gallon}}{4}$

and $264 \text{ L} = 264 \cdot \frac{1 \text{ gallon}}{4}$
 $= 66 \text{ gallons}$

This means that it takes 66 gallons of water to *grow* the corn **and** *convert* it into 1 liter of ethanol.

- If your car holds 13 gallons of gas and 10% is ethanol, then you have
 $10\% \text{ of } 13 = 0.10 \cdot 13 = 1.3 \text{ gallons of ethanol}$
- Since $1 \text{ gallon} \approx 4 \text{ L}$, $1.3 \text{ gallons} = 1.3 \cdot 4 \text{ L} = 5.2 \text{ L}$ of ethanol. Now, 264 liters of water are used to *grow* the corn and *convert* it into 1 liter of ethanol, so $264 \cdot 5.2 \text{ L} = 1372.8 \text{ liters}$ of water were used to *grow* the corn and *convert* it to the 1.3 gallons of ethanol.

Note: It takes 3–4 gallons of water to *convert* the corn to ethanol *after* the corn is *grown*, but it takes additional water to grow the corn!

PROBLEM 7

- Convert 784 liters to gallons.
- An SUV has a 20-gallon tank. How many gallons is ethanol?
- How many liters are ethanol and how much water was used to *grow* the corn and *convert* it to ethanol, assuming that 784 liters of water are needed to both grow the corn and convert it to 1 liter of ethanol?



Read more about ethanol at <http://tinyurl.com/m4p5oq>.

> Exercises 7.5



> Practice Problems > Self-Tests
 > Media-rich eBooks > e-Professors > Videos

< **A** > **U.S. (American) to Metric Conversion** In Problems 1–10, use the fact that $1 \text{ qt} \approx 1 \text{ L}$ to fill in the blanks.

1. $\frac{3}{4} \text{ gal} \approx$ _____ L

2. $\frac{1}{8} \text{ gal} \approx$ _____ L

3. $2 \text{ L} \approx$ _____ qt

4. $5 \text{ L} \approx$ _____ qt

5. $8 \text{ L} \approx$ _____ gal

6. $12 \text{ L} \approx$ _____ gal

7. $5 \text{ gal} \approx$ _____ L

8. $6 \text{ gal} \approx$ _____ L

9. $8 \text{ qt} \approx$ _____ L

10. $12 \text{ qt} \approx$ _____ L

Answers to PROBLEMS

7. a. 196 gallons b. 2 gallons
 c. 8 liters; 6272 liters

< B > Converting from One Metric Measure to Another Use this table to solve Problems 11–30.

kiloliter (kL)	hectoliter (hL)	dekaliter (daL)	liter (L)	deciliter (dL)	centiliter (cL)	milliliter (mL)
1000 L	100 L	10 L	1 L	$\frac{1}{10}$ L	$\frac{1}{100}$ L	$\frac{1}{1000}$ L

11. 177 mL = _____ L 12. 781 mL = _____ L 13. 3847 mL = _____ L
 14. 9381 mL = _____ L 15. 205 cL = _____ L 16. 804 cL = _____ L
 17. 55 dL = _____ L 18. 49 dL = _____ L 19. 6 daL = _____ L
 20. 11 daL = _____ L 21. 7 hL = _____ L 22. 13 hL = _____ L
 23. 6 kL = _____ L 24. 5 kL = _____ L 25. 5 kL = _____ daL
 26. 8 kL = _____ daL 27. 4 daL = _____ cL 28. 8 daL = _____ cL
 29. 9 daL = _____ dL 30. 7 daL = _____ dL
31. A permanganate solution has 200 mL of permanganate and 1800 mL of water.
 a. Change 200 mL to liters.
 b. Change 1800 mL to liters.
32. A Lysol solution has 160 mL of Lysol and 3840 mL of water.
 a. Change 160 mL to liters.
 b. Change 3840 mL to liters.
33. A 44-lb patient needs to receive 1500 mL of fluids to meet his fluid maintenance needs. How many liters is that?
34. A 30-kg patient needs 1700 mL of fluids to meet her fluid maintenance needs. How many liters is that?

< C > Applications Involving U.S. and Metric Units of Volume

Cleaning products The following information for mixing a general-purpose cleaner will be used in Problems 35–40.

35. How many mL of borax are there in the cleaner?
 36. How many mL of washing soda are there in the cleaner?
 37. How many mL of vinegar are there in the cleaner?
 38. How many mL of dishwashing liquid are there in the cleaner?
 39. How many mL of hot water are there in the cleaner?
 40. How many liters of cleaner will result when you mix all ingredients?
 41. *Pain reliever* Biofreeze, a pain-relieving gel, is sold in a 15-fluid-ounce size. How many mL is that?
 43. *Eye drops* Clear Eyes eye drops come in a 0.5-fluid-ounce bottle. How many mL is that?
 45. *Vitamins* Centrum liquid vitamin comes in a 240-mL bottle. How many fluid ounces is that?
 47. *Fluid per day* A child weighing 15 kg requires 1500 mL of fluid per day.
 a. How many fluid ounces per day is that?
 b. How many cups of fluid per day is that?

General-Purpose Cleaner

1 teaspoon borax
 $\frac{1}{2}$ teaspoon washing soda (found in laundry section of stores)
 2 teaspoons vinegar
 $\frac{1}{4}$ teaspoon dishwashing liquid
 2 cups hot water

Source: Data from *The Old Farmer's Almanac*.

42. *Medicine* Stopain spray comes in an 11.25-fluid-ounce bottle. How many mL is that?
 44. *Mouth wash* The dosage for Periocheck mouth rinse is $\frac{1}{8}$ fluid ounce per rinse. How many mL is that?
 46. *Medicine* Mylanta comes in a 720-mL bottle. How many fluid ounces is that?
 48. *Fluid per day* A child who weighs 8 kg requires 800 mL of fluid per day.
 a. How many fluid ounces per day is that?
 b. How many cups of fluid per day is that?

49. *Daily water* How much water should a patient drink each day? The Institute of Medicine advises that men consume about 13 cups of total beverages a day.
- How many mL is that?
 - How many fluid ounces is that?
50. *Daily water* What about women? They should consume about 9 cups of total beverages a day.
- How many mL is that?
 - How many fluid ounces is that?

Applications: Green Math

Ethanol and water: Who do you believe?

51. Researchers at the University of Minnesota have concluded that the amount of water used in ethanol production varies hugely from state to state, ranging from 5 to 2138 liters of water per liter of ethanol. Change 2138 liters to gallons.
52. In some states, such as Ohio, Iowa, and Kentucky, where corn can grow with little to no irrigation, only 5 to 7 liters of water are required to turn the foodstuff into fuel. Change 7 liters to gallons.
53. The U.S. Energy Independence and Security Act of 2007 mandates that ethanol produced using existing technologies will have to increase from the 34 billion liters produced in 2008 to 57 billion liters per year by 2015.
54. One bushel of corn will make approximately 2.8 gallons of ethanol. How many liters is that?
- Change 34 billion liters to gallons.
 - Change 57 billion liters to gallons.

Source: <http://beta.technologyreview.com/energy/22428/>.

55. In a recent year, three billion bushels of corn were used to make 8.3 billion gallons of ethanol in the US. Change 8.3 billion gallons to liters.
56. A modern ethanol plant uses 3–4 gallons of water to produce one gallon of ethanol.
- Change 3 gallons to liters.
 - Change 4 gallons to liters.

Source: <http://tinyurl.com/m4p5oq>.

Using Your Knowledge

57. *Eye drops* The dosage for Clear Eyes eye drops is two drops per eye, four times a day.
- How many drops per day is that?
 - If one drop is 0.2 mL, how many mL are used each day?
 - If Clear Eyes comes in a 15 mL bottle, about how many days will the bottle last? Answer to four decimal places.
58. *Mouthwash* The dosage for Periocheck mouth rinse is $\frac{1}{8}$ fluid ounces two times a day.
- How many fluid ounces per day is that?
 - If the bottle of Periocheck contains 10 fluid ounces of liquid, how many days will it last?

Write On

59. Write in your own words the advantages of the metric over the American system when measuring capacities.
60. Can you think of other household measures that were not mentioned in the text? What are they and how are they used?

Concept Checker

Fill in the blank(s) with the correct word(s), phrase, or mathematical statement.

61. A **milliliter** is defined as the volume of a cube one _____ on each edge. **liter** **cm**
62. A _____ is the **volume of a cube** 10 cm on each edge. **in** **quart**
- m**

>>> Mastery Test

63. A doctor orders 25 fluid ounces of IV fluid for a patient.
- How many mL is that?
 - How many cc is that?
64. A recipe calls for 600 mL of cream of mushroom soup. How many cups is that?
65. A rug-cleaning solution is made by mixing $\frac{1}{4}$ teaspoon dishwashing liquid and 1 cup lukewarm water. How many mL of dishwashing liquid and how many mL of water do you need?

Fill in the blanks.

66. a. 3 gal \approx _____ L 67. 10 kL = _____ L 68. 347 mL = _____ L
- b. 16 oz \approx _____ L

>>> Skill Checker

In Problems 69–72, perform the indicated operations.

69. $80 \cdot \frac{1}{16}$

70. $5000 \cdot \frac{1}{2000}$

71. $6 \cdot 0.45$

72. $\frac{5(41 - 32)}{9}$

7.6

Weight and Temperature: U.S., Metric, and Conversions

▶ Objectives

You should be able to:

- A** > Convert a U.S. unit of weight to an equivalent U.S. unit of weight.
- B** > Convert a metric unit of mass to an equivalent metric unit of mass.
- C** > Convert a U.S. unit of weight to an equivalent metric unit of weight and vice versa.
- D** > Convert temperatures from Celsius to Fahrenheit and vice versa.

▶ To Succeed, Review How To . . .

- Multiply fractions. (pp. 135–141)
- Multiply decimals. (pp. 222–226)

▶ Getting Started



CROCK © 1957 NORTH AMERICA SYNDICATE

A > Converting U.S. Units of Weight

In the cartoon, the prisoner is getting three glops of food a day. To discuss how much food that is, we need a system of **unit weights**. The customary system (also called the avoirdupois system) uses the following units of weight:

U.S. Units of Weight

$$\begin{array}{ll} 1 \text{ ton} = 2000 \text{ pounds (lb)} & 1 \text{ pound} = \frac{1}{2000} \text{ ton} \\ 1 \text{ pound} = 16 \text{ ounces (oz)} & 1 \text{ oz} = \frac{1}{16} \text{ lb} \end{array}$$

We can change from one unit to another in the customary system by using *substitution*. For example, to solve

$$3 \text{ lb} = \underline{\hspace{2cm}} \text{ oz}$$

we write

$$3 \text{ lb} = 3 \cdot (16 \text{ oz}) = 48 \text{ oz}$$

Similarly, to solve the problem

$$80 \text{ oz} = \underline{\hspace{2cm}} \text{ lb}$$

we write

$$80 \text{ oz} = 80 \cdot \left(\frac{1}{16} \text{ lb}\right) = \frac{80}{16} \text{ lb} = 5 \text{ lb}$$

We can also use **unit fractions**. Since 1 lb contains 16 oz,

$$1 = \frac{1 \text{ lb}}{16 \text{ oz}}$$

and

$$\begin{aligned} 80 \text{ oz} &= 80 \text{ oz} \cdot 1 = 80 \text{ oz} \cdot \frac{1 \text{ lb}}{16 \text{ oz}} \\ &= 5 \text{ lb} \end{aligned}$$

EXAMPLE 1 Converting pounds to ounces

$$2 \text{ lb} = \underline{\hspace{2cm}} \text{ oz}$$

SOLUTION 1

$$2 \text{ lb} = 2 \cdot (16 \text{ oz}) = 32 \text{ oz}$$

PROBLEM 1

$$4 \text{ lb} = \underline{\hspace{2cm}} \text{ oz}$$

EXAMPLE 2 Converting ounces to pounds

$$48 \text{ oz} = \underline{\hspace{2cm}} \text{ lb}$$

SOLUTION 2

$$48 \text{ oz} = 48 \cdot \left(\frac{1}{16} \text{ lb}\right) = 48 \cdot \frac{1}{16} \text{ lb} = 3 \text{ lb}$$

PROBLEM 2

$$32 \text{ oz} = \underline{\hspace{2cm}} \text{ lb}$$

GREEN MATH

EXAMPLE 3 Converting tons of pollution to pounds

Natural gas drilling in Dallas-Fort Worth produces about 112 tons of pollution per day. How many pounds is that?

SOLUTION 3

$$\begin{aligned} \text{We need to find} \quad 112 \text{ tons} &= \underline{\hspace{2cm}} \text{ pounds} \\ 112 \text{ tons} &= 112 \cdot (2000 \text{ lb}) = 224,000 \text{ lb} \end{aligned}$$

PROBLEM 3

Car and truck traffic produce 120 tons of pollution per day. How many pounds is that?

Source: Al Armendariz, SMU.

Answers to PROBLEMS

1. 64 oz 2. 2 lb
3. 240,000 lb

GREEN MATH

EXAMPLE 4 Converting pounds of pollution to tons

If your car gets 25 miles per gallon and you drive it 1000 miles a month, your car will produce about 12,000 pounds of carbon dioxide. How many tons is that?

SOLUTION 4

We need to find $12,000 \text{ lb} = \underline{\hspace{2cm}}$ tons
 $12,000 \text{ lb} = 12,000 \cdot \left(\frac{1}{2000} \text{ ton}\right) = 6 \text{ tons}$

PROBLEM 4

If your car gets 30 miles per gallon and you drive it 1000 miles a month, your car will produce about 8000 pounds of carbon dioxide. How many tons is that?

Source: <http://www.terrapass.com>.

B > Converting Metric Units of Mass

As usual, the metric system is easier. In this system the unit of **mass** is called the gram. (Note that we wrote *mass* and not *weight*. There is a difference, but the terms are used interchangeably.)* A **gram** is the mass of 1 cm³ (1 mL) of water. Here is the table giving the information used to convert from one unit to another in the metric system:

kilogram (kg)	hectogram (hg)	dekagram (dag)	gram (g)	decigram (dg)	centigram (cg)	milligram (mg)
1000 g	100 g	10 g	1 g	$\frac{1}{10}$ g	$\frac{1}{100}$ g	$\frac{1}{1000}$ g

Converting from one unit to another is just a matter of moving the decimal point the correct number of places. Thus, to solve

$$3 \text{ hg} = \underline{\hspace{2cm}} \text{ cg}$$

we have to move from hectograms to centigrams in the table; that is, we have to move four places to the right. Thus, we move the decimal point in 3 four places to the right, obtaining

$$3 \text{ hg} = 30,000 \text{ cg}$$

EXAMPLE 5 Converting dekagrams to decigrams

$$4 \text{ dag} = \underline{\hspace{2cm}} \text{ dg}$$

SOLUTION 5 To move from dekagrams to decigrams in the table, we have to move *two* places to the right. Thus we move the decimal point in 4 *two* places to the right, obtaining

$$4 \text{ dag} = 400 \text{ dg}$$

PROBLEM 5

$$3 \text{ dag} = \underline{\hspace{2cm}} \text{ dg}$$

EXAMPLE 6 Converting milligrams to grams

$$401 \text{ mg} = \underline{\hspace{2cm}} \text{ g}$$

SOLUTION 6 To move from milligrams to grams in the table, we have to move *three* places to the left. Thus we move the decimal point in 401 *three* places to the left, obtaining

$$401 \text{ mg} = 0.401 \text{ g}$$

PROBLEM 6

$$103 \text{ mg} = \underline{\hspace{2cm}} \text{ g}$$

*Weight is related to the force of gravity and mass is not. If you weigh 150 pounds on Earth you would only weigh 25 pounds on the moon (gravity is less there), but your mass would be the same as on Earth.

Answers to PROBLEMS

4. 4 tons 5. 300 dg 6. 0.103 g

C > Converting Units of Weight between Metric and U.S. (American) Customary

We are now ready to convert weights from the U.S. customary system to the metric system, or vice versa. To do this we need the following table:

U.S. System to Metric Conversions

$$1 \text{ kg} = 2.2 \text{ lb}$$

$$1 \text{ lb} = 0.45 \text{ kg}$$

GREEN MATH

EXAMPLE 7 Converting kilograms of pollution to pounds

Each person in the United States generates 460 kg of waste each year. How many pounds is that?

SOLUTION 7

$$460 \text{ kg} = 460 \cdot (2.2 \text{ lb}) = 1012 \text{ lb}$$

Thus, each person generates 1012 lb of waste each year.

PROBLEM 7

Each person in Denmark produces 560 kg of waste each year. How many pounds is that? Denmark is number one in per capita waste production!

Source: <http://www.nationmaster.com>.

GREEN MATH

EXAMPLE 8 Converting pounds of pollution to kilograms

The average adult receives 40 pounds of junk mail each year. How many kilograms is that? By the way, 44% goes to the landfill unopened.

SOLUTION 8

$$40 \text{ lb} = 40 \cdot (0.45 \text{ kg}) = 18 \text{ kg}$$

PROBLEM 8

The average person uses about 700 pounds of paper products per year. How many kilograms is that?

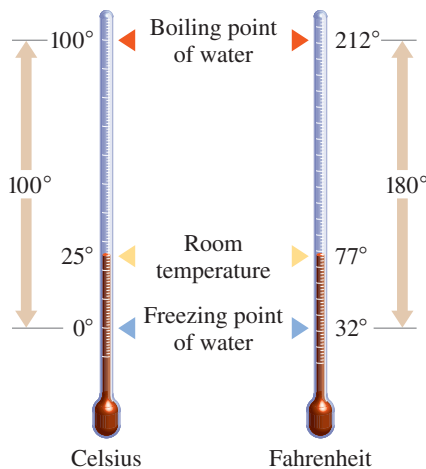

Comparison of the Celsius and Fahrenheit thermometer scales

D > Converting from Fahrenheit to Celsius and Vice Versa

Finally, we study the measurement of temperatures in both the customary and the metric systems. The customary temperature scale was invented in 1714 by Gabriel Daniel Fahrenheit, a German scientist. In this scale, called the **Fahrenheit** scale, the point at which water boils was labeled 212°F (read “212 degrees Fahrenheit”), and the point at which water freezes was labeled 32°F. The Fahrenheit scale was later modified by Anders Celsius. This new scale, called the **Celsius** scale, was divided into 100 units. (The Celsius scale used to be called the centigrade scale because it has 100 units.) The boiling point occurs at 100°C (read “100 degrees Celsius”) and the freezing point at 0°C. You can see how the temperatures in these two scales are compared by looking at the drawing.

Answers to PROBLEMS

7. 1232 lb 8. 315 kg

Here are the formulas for converting from one scale to the other. In these formulas C stands for the Celsius temperature and F for the Fahrenheit temperature.

Temperature Conversions

$$C = \frac{5(F - 32)}{9} \qquad F = \frac{9C}{5} + 32$$

Note that $5(F - 32)$ means $5 \cdot (F - 32)$, $9C$ means $9 \cdot C$, and that $F - 32$ is in *parentheses*. This means that when F is known, $F - 32$ is calculated *first*.

At the freezing point of water, $F = 32$ and

$$C = \frac{5(32 - 32)}{9} = \frac{5(0)}{9} = 0$$

Similarly, at the boiling point of water, $C = 100$ and

$$\begin{aligned} F &= \frac{9 \cdot 100}{5} + 32 = \frac{900}{5} + 32 \\ &= 180 + 32 = 212 \end{aligned}$$

EXAMPLE 9 Converting from Fahrenheit to Celsius

$$41^\circ\text{F} = \underline{\hspace{2cm}}^\circ\text{C}$$

SOLUTION 9 From the table,

$$C = \frac{5(F - 32)}{9} = \frac{5(41 - 32)}{9} = \frac{5 \cdot 9}{9} = 5$$

Thus, $41^\circ\text{F} = 5^\circ\text{C}$.

PROBLEM 9

$$50^\circ\text{F} = \underline{\hspace{2cm}}^\circ\text{C}$$

EXAMPLE 10 Converting from Celsius to Fahrenheit

$$15^\circ\text{C} = \underline{\hspace{2cm}}^\circ\text{F}$$

SOLUTION 10 From the table,

$$F = \frac{9C}{5} + 32 = \frac{9 \cdot 15}{5} + 32 = 27 + 32 = 59$$

Thus, $15^\circ\text{C} = 59^\circ\text{F}$.

PROBLEM 10

$$20^\circ\text{C} = \underline{\hspace{2cm}}^\circ\text{F}$$



Calculator Corner

The formula to convert degrees Fahrenheit to Celsius is especially suitable for a calculator with parentheses $()$ keys. But the calculator does not do it all. You must know that to convert 41°F to degrees Celsius, you must multiply 5 by $(F - 32)$ and then divide by 9. The computation in Example 9 is like this:

$$F = \frac{5(41 - 32)}{9}$$

With a calculator, press 5 \times (4 1 - 3 2) \div 9 **ENTER** and the correct answer, 5, will be given.

If your calculator does not have parentheses keys, you must know even more! To find the answer using a calculator without parentheses keys, find $41 - 32$ first, as explained in the text. The calculations look like this:

$$4 1 - 3 2 \text{ ENTER } \times 5 \div 9 \text{ ENTER}$$

Answers to PROBLEMS

9. 10°C 10. 68°F

> Exercises 7.6



> Practice Problems > Self-Tests
> Media-rich eBooks > e-Professors > Videos

< A > Converting U.S. Units of Weight In Problems 1–16, fill in the blanks.

- | | | |
|---------------------------------|------------------------------------|--------------------------|
| 1. 3 lb = _____ oz | 2. 5 lb = _____ oz | 3. 4.5 lb = _____ oz |
| 4. $3\frac{1}{2}$ lb = _____ oz | 5. 64 oz = _____ lb | 6. 96 oz = _____ lb |
| 7. 72 oz = _____ lb | 8. 40 oz = _____ lb | 9. 4 tons = _____ lb |
| 10. 5 tons = _____ lb | 11. $2\frac{1}{2}$ tons = _____ lb | 12. 4.5 tons = _____ lb |
| 13. 3000 lb = _____ tons | 14. 9000 lb = _____ tons | 15. 4000 lb = _____ tons |
| 16. 6000 lb = _____ tons | | |

< B > Converting Metric Units of Mass Use this table to solve Problems 17–30.

kilogram (kg)	hectogram (hg)	dekagram (dag)	gram (g)	decigram (dg)	centigram (cg)	milligram (mg)
1000 g	100 g	10 g	1 g	$\frac{1}{10}$ g	$\frac{1}{100}$ g	$\frac{1}{1000}$ g

- | | | |
|----------------------|----------------------|----------------------|
| 17. 2 kg = _____ cg | 18. 4 kg = _____ cg | 19. 2 dag = _____ dg |
| 20. 5 dag = _____ dg | 21. 2 kg = _____ dag | 22. 6 kg = _____ dag |
| 23. 5 dag = _____ g | 24. 4 dag = _____ g | 25. 899 mg = _____ g |
| 26. 301 mg = _____ g | 27. 30 mg = _____ g | 28. 51 mg = _____ g |
| 29. 57 cg = _____ g | 30. 64 cg = _____ g | |

< C > Converting Units of Weight between Metric and U.S. (American) Customary In Problems 31–40, fill in the blanks.

- | | | |
|----------------------|----------------------|----------------------|
| 31. 4 kg = _____ lb | 32. 5 kg = _____ lb | 33. 10 kg = _____ lb |
| 34. 12 kg = _____ lb | 35. 2 lb = _____ kg | 36. 8 lb = _____ kg |
| 37. 10 kg = _____ hg | 38. 20 kg = _____ hg | 39. 16 oz = _____ kg |
| 40. 64 oz = _____ kg | | |

< D > Converting from Fahrenheit to Celsius and Vice Versa In Problems 41–50, fill in the blanks.

- | | | |
|---|--|--|
| 41. $59^{\circ}\text{F} =$ _____ $^{\circ}\text{C}$ | 42. $68^{\circ}\text{F} =$ _____ $^{\circ}\text{C}$ | 43. $77^{\circ}\text{F} =$ _____ $^{\circ}\text{C}$ |
| 44. $86^{\circ}\text{F} =$ _____ $^{\circ}\text{C}$ | 45. $113^{\circ}\text{F} =$ _____ $^{\circ}\text{C}$ | 46. $122^{\circ}\text{F} =$ _____ $^{\circ}\text{C}$ |
| 47. $10^{\circ}\text{C} =$ _____ $^{\circ}\text{F}$ | 48. $25^{\circ}\text{C} =$ _____ $^{\circ}\text{F}$ | 49. $35^{\circ}\text{C} =$ _____ $^{\circ}\text{F}$ |
| 50. $30^{\circ}\text{C} =$ _____ $^{\circ}\text{F}$ | | |

>>> Applications

- | | |
|---|--|
| 51. <i>Melting point of gold</i> The melting point of gold is 1000°C . How many degrees Fahrenheit is that? | 52. <i>Normal body temperature</i> The normal body temperature is 98.6°F . How many degrees Celsius is that? |
| 53. <i>High fever</i> 104°F is considered a high fever. How many degrees Celsius is that? | 54. <i>Weight</i> A woman weighs 48 kg. How many pounds is that? |
| 55. <i>Weight</i> A man weighs 160 lb. How many kilograms is that? | 56. <i>Air temperature</i> The highest dry-air temperature endured by heavily clothed men in an Air Force experiment was 500°F . How many degrees Celsius is that? |

- 57. Coimbra temperature** In September 1933, the temperature in Coimbra, Portugal, rose to 70°C . How many degrees Fahrenheit is that?
- 58. Death Valley temperature** On July 10, 1913, the temperature in Death Valley was 134°F . How many degrees Celsius is that?
- 59. Maximum weight for flyweight** The maximum weight for a flyweight wrestler is 52 kg. How many pounds is that?
- 60. Maximum weight for bantamweight** The maximum weight for a bantamweight wrestler is $123\frac{1}{4}$ lb. How many kilograms is that?

Did you know that there are two kinds of elephants, African and Asian? Let us look at some facts about each of them.

Source: <http://www.sandiegozoo.org>.

- 61. Elephants** In general, wild elephants eat all types of vegetation, from grass and fruit to leaves and bark—about 220 to 440 pounds each day. How many kilograms is that?
- 62. Elephants** The elephants at the San Diego Zoo eat less: about 125 pounds of food each day. How many kilograms is that? Round your answer to the nearest kilogram.
- 63. Elephants** The largest elephant on record was an adult male African elephant. It weighed about 10,886 kilograms. How many pounds is that? Round your answer to the nearest pound.
- 64. Elephants** At birth, an elephant weighs 50 to 113 kg. How many pounds is that? Round your answer to the nearest pound. By the way, the gestation (pregnancy) period for elephants is 20 to 22 months.



>>> Using Your Knowledge

>>> Applications: Green Math

The 10 warmest years in the instrumental record of global temperatures (since 1880) all occur within the 12-year period from 1997 to 2008. Use your knowledge to see what these temperatures are on the Celsius and the Fahrenheit scales.

- 65. Temperature in Melbourne, Australia** In January 2009, Melbourne experienced three successive days of temperatures above 43°C for the first time in recorded history. Convert 43°C to Fahrenheit.
- 66. Heat wave in Adelaide, Australia** Adelaide experienced its longest running heat wave on record, with 15 consecutive days of maximum temperatures above 35°C . Convert 35°C to Fahrenheit.
- 67. Heat waves in the United States** Air temperatures in many parts of the United States reached 104°F or more in 2006. Convert 104°F to Celsius.
- 68. Heat waves in Brazil** Heat waves were registered in Brazil from January until March 2006 with temperatures reaching 112°F . Convert 112°F to Celsius.

Source: <http://www.global-greenhouse-warming.com/global-temperature.html>.

The chart shows the **Low**, **Best**, and **High** temperature estimates in Celsius degrees from 1880 to 2100. **To the nearest degree:**

- 69.** What was the estimated temperature in Celsius and Fahrenheit in the year 1880?
- 70.** What was the **Low** estimate in Celsius and Fahrenheit for the year 2100?
- 71.** What was the **Best** estimate in Celsius and Fahrenheit for the year 2100?
- 72.** What was the **High** estimate in Celsius and Fahrenheit for the year 2100?
- 73.** What is the temperature difference in Celsius and Fahrenheit between the **Low** and the **High** estimates for the year 2100?

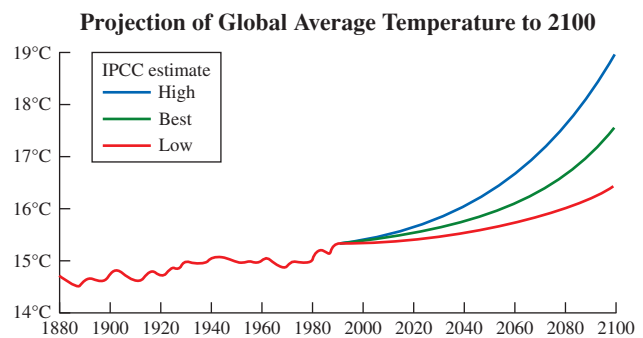

Source: UNEP, 1996.

Source: <http://tinyurl.com/mwrogh>.

>>> Write On

74. Write in your own words the advantages of the metric system over the U.S. (American) system when measuring weight.
75. Do you know of any other measures for weight? What are they and how are they used?
76. Write in your own words how to use estimation to make the calculations in this section.

>>> Concept Checker

Fill in the blank(s) with the correct word(s), phrase, or mathematical statement.

77. A _____ is the **mass** of **1 cm³** (cubic centimeter) of water.
78. In the **customary** (U.S.) system, **temperature** is measured in degrees _____ while the **metric system** is measured in degrees _____.

kilogram	pound
Fahrenheit	Celsius
gram	

>>> Mastery Test

79. $40^{\circ}\text{C} = \underline{\hspace{2cm}} \text{ F}$
80. $68^{\circ}\text{F} = \underline{\hspace{2cm}} \text{ C}$
81. $8 \text{ kg} = \underline{\hspace{2cm}} \text{ lb}$
82. $10 \text{ lb} = \underline{\hspace{2cm}} \text{ kg}$
83. $384 \text{ mg} = \underline{\hspace{2cm}} \text{ g}$
84. $8 \text{ dag} = \underline{\hspace{2cm}} \text{ dg}$
85. $12,000 \text{ lb} = \underline{\hspace{2cm}} \text{ tons}$
86. $7 \text{ tons} = \underline{\hspace{2cm}} \text{ lb}$
87. $160 \text{ oz} = \underline{\hspace{2cm}} \text{ lb}$
88. $6 \text{ lb} = \underline{\hspace{2cm}} \text{ oz}$

>>> Skill Checker

Evaluate:

89. $180 - x$, when $x = 50$
90. $180 - x$, when $x = 160$
91. $180 - x - 59$, when $x = 47$
92. $180 - x - 48$, when $x = 45$

> Collaborative Learning

The object of this Collaborative Learning is to propose a method for converting the United States to the metric system. Form three groups of students:

1. Commercial users
2. General users
3. Scientific users

Questions to be answered by each group:

Group 1 (Farmers, manufacturers, producers)

1. Why does the United States need to change to the metric system?
2. Why doesn't the United States accept the metric system, even though it is now used in other countries?
3. What are the advantages and disadvantages of the metric system?
4. What would your plan be to convert the United States to metric?

Group 2 (Household users, mechanics, builders, students)

1. What are the benefits of having all measurements in metric rather than in a combination of standard and metric?
2. Name some items measured in standard measurement, some items measured in metric, and some items measured in both.
3. Why is the government interested in changing to metric?

4. What would your plan be to convert the United States to metric?

Group 3 (Researchers, students in medical professions)

1. What are the benefits of a total metric system adoption in the United States?
2. How difficult would it be for the general public to learn the metric system? How can you make it easier?
3. Why is the federal government making the metric transition?
4. What would your plan be to convert the United States to metric?

Adapted from: Metric System: A WebQuest for 7–10 Grade Science by Deborah L. Folis



Research Questions

1. When was the metric system made legal (but not mandatory) in the United States?
2. Write a paragraph about Gabriel Mouton and his contribution to the creation of the metric system.
3. Where are the words *inch*, *foot*, and *yard* derived from?
4. When was the Metric Conversion Act passed by Congress?
5. Find the official definition of:
 - a. The unit of length (meter)
 - b. The unit of mass (kilogram)
 - c. The unit of time (second)
6. What is the “iron ulna,” what distance did it represent, and what king used it as measurement?

Summary Chapter 7

Section	Item	Meaning	Example
7.1A, B	Inch	The breadth of a thumb, defined as $\frac{1}{12}$ of a foot	12 in. = 1 ft
	Foot	Length of a man's foot (12 in.)	
	Yard	The circumference of a person's waist, defined as 36 inches	
	Unit fractions	Fractions that equal 1	
7.2A	Kilometer	1 kilometer = 1000 meters	5 km = 5000 m
	Hectometer	1 hectometer = 100 meters	3 hm = 300 m
	Dekameter	1 dekameter = 10 meters	4 dam = 40 m
	Meter	The basic unit of length in the metric system	
	Decimeter	1 decimeter = $\frac{1}{10}$ meter	7 dm = $\frac{7}{10}$ m
	Centimeter	1 centimeter = $\frac{1}{100}$ meter	9 cm = $\frac{9}{100}$ m
	Millimeter	1 millimeter = $\frac{1}{1000}$ meter	3 mm = $\frac{3}{1000}$ m

Section	Item	Meaning	Example
7.3A	Inch Yard Mile Centimeter Meter Kilometer	1 in. = 2.54 cm 1 yd = 0.914 m 1 mi = 1.6 km 1 cm = 0.4 in. 1 m = 1.1 yd 1 km = 0.62 mi	2 in. = 5.08 cm 3 yd = 2.742 m 5 mi = 8.0 km 5 cm = 2.0 in. 10 m = 11 yd 10 km = 6.2 mi
7.4A, B, C	1 in. ² 1 ft ² 1 hectare 1 acre	$\frac{1}{144}$ ft ² $\frac{1}{9}$ yd ² 10,000 m ² = 2.47 acres 4840 yd ²	20,000 m ² = 4.94 acres
7.5	Liter Quart Liter	Volume of a cube 10 cm on each edge 0.946 L 1.06 qt	2 qt = 1.892 L 4 L = 4.24 qt
7.5B	Kiloliter Hectoliter Dekaliter Liter Deciliter Centiliter Milliliter	1 kL = 1000 L 1 hL = 100 L 1 daL = 10 L The basic unit of volume in the metric system 1 dL = $\frac{1}{10}$ L 1 cL = $\frac{1}{100}$ L 1 mL = $\frac{1}{1000}$ L	5 kL = 5000 L 3 hL = 300 L 10 daL = 100 L 7 dL = $\frac{7}{10}$ L 9 cL = $\frac{9}{100}$ L 3 mL = $\frac{3}{1000}$ L
7.5C	Teaspoon Tablespoon Fluid ounce Cup cm ³	5 mL 15 mL 30 mL 240 mL cc (cubic centimeter)	2 Teaspoons = 10 mL 2 Tablespoons = 30 mL 3 Fluid ounces = 90 mL 2 Cups = 480 mL
7.6A	1 Ton 1 Pound 1 Pound 1 Ounce	2000 lb $\frac{1}{2000}$ ton 16 oz $\frac{1}{16}$ lb	2 tons = 4000 lb 4000 lb = 2 tons 3 pounds = 48 oz 32 ounces = 2 lb
7.6B	Kilogram Hectogram Dekagram Gram Decigram Centigram Milligram	1 kg = 1000 g 1 hg = 100 g 1 dag = 10 g The basic unit of mass in the metric system 1 dg = $\frac{1}{10}$ g 1 cg = $\frac{1}{100}$ g 1 mg = $\frac{1}{1000}$ g	10 kg = 10,000 g 5 hg = 500 g 7 dag = 70 g 7 dg = $\frac{7}{10}$ g 3 cg = $\frac{3}{100}$ g 9 mg = $\frac{9}{1000}$ g

(continued)

Section	Item	Meaning	Example
7.6C	1 Kilogram 1 Pound	2.2 lb 0.45 kg	2 kg = 4.4 lb 10 lb = 4.5 kg
7.6D	Degree Celsius Degree Fahrenheit	$C = \frac{5(F-32)}{9}$ (F = the Fahrenheit temperature) $F = \frac{9C}{5} + 32$ (C = the Celsius temperature)	$41^\circ F = \frac{5(41 - 32)}{9} = 5^\circ C$ $10^\circ C = \frac{9 \cdot 10}{5} + 32 = 50^\circ C$

Review Exercises Chapter 7

(If you need help with these exercises, look in the section indicated in brackets.)

- 1.** **<7.1A>** Find how many inches there are in:
 - 2 yd
 - 3 yd
 - 4 yd
 - 6 yd
 - 7 yd
- 2.** **<7.1A>** Find how many feet there are in:
 - 12 in.
 - 24 in.
 - 36 in.
 - 40 in.
 - 65 in.
- 3.** **<7.1A>** Find how many feet there are in:
 - 2 in.
 - 3 in.
 - 5 in.
 - 7 in.
 - 14 in.
- 4.** **<7.1A>** Find how many yards there are in:
 - 6 ft
 - 12 ft
 - 18 ft
 - 20 ft
 - 29 ft
- 5.** **<7.1A>** Find how many miles there are in:
 - 5280 ft
 - 10,560 ft
 - 26,400 ft
 - 21,120 ft
 - 15,840 ft
- 6.** **<7.2A>** Find how many meters there are in:
 - 2 km
 - 7 km
 - 4.6 km
 - 0.45 km
 - 45 km
- 7.** **<7.2A>** Find how many meters there are in:
 - 2 dam
 - 3 dam
 - 7 dam
 - 9 dam
 - 10 dam
- 8.** **<7.2A>** Find how many decimeters there are in:
 - 100 m
 - 300 m
 - 350 m
 - 450 m
 - 600 m
- 9.** **<7.2A>** Find how many meters there are in:
 - 200 cm
 - 395 cm
 - 405 cm
 - 234 cm
 - 499 cm
- 10.** **<7.3A>** Find how many cm there are in:
 - 30 in.
 - 40 in.
 - 50 ft
 - 60 ft
 - 70 ft
- 11.** **<7.3A>** Find how many meters there are in:
 - 100 yd
 - 200 yd
 - 350 yd
 - 450 yd
 - 500 yd
- 12.** **<7.3A>** Find how many kilometers there are in:
 - 30 mi
 - 50 mi
 - 90 mi
 - 100 mi
 - 250 mi

13. <7.3A> Find how many miles there are in:
- 40 km
 - 50 km
 - 60 km
 - 70 km
 - 80 km
14. <7.4A> Find how many square centimeters there are in:
- 2 m^2
 - 3 m^2
 - 4 m^2
 - 5 m^2
 - 6 m^2
15. <7.4A> Find how many square meters there are in:
- 2 km^2
 - 3 km^2
 - 4 km^2
 - 5 km^2
 - 6 km^2
16. <7.4B> Find how many square inches there are in:
- 2 ft^2
 - 3 ft^2
 - 4 ft^2
 - 5 ft^2
 - 6 ft^2
17. <7.4B> Find how many square feet there are in:
- 144 in.^2
 - 288 in.^2
 - 360 in.^2
 - 432 in.^2
 - 504 in.^2
18. <7.4B> Find the area, in square yards, of:
- A 1-acre lot
 - A 3-acre lot
 - A 2-acre lot
 - A 1.5-acre lot
 - A 4-acre lot
19. <7.4C> Find how many acres there are in:
- 5 hectares
 - 4 hectares
 - 1 hectare
 - 3 hectares
 - 2 hectares
20. <7.5A> Find (approximately) how many liters there are in:
- 7 qt
 - 9 qt
 - 10 qt
 - 13 qt
 - 2.2 qt
21. <7.5B> Find how many liters there are in:
- 4 kL
 - 7 kL
 - 9 kL
 - 2.3 kL
 - 5.97 kL
22. <7.5B> Find how many liters there are in:
- 452 mL
 - 48 mL
 - 3 mL
 - 1657 mL
 - 456 mL
23. <7.5C> Find how many mL there are in:
- 4 cups
 - 5 cups
 - 6 cups
 - 7 cups
 - 9 cups
24. <7.5C> Find how many cups there are in:
- 120 mL
 - 360 mL
 - 480 mL
 - 600 mL
 - 720 mL
25. <7.5C> Find how many mL there are in:
- 120 fluid ounces
 - 180 fluid ounces
 - 240 fluid ounces
 - 300 fluid ounces
 - 360 fluid ounces
26. <7.5C> Find how many mL there are in:
- 7 tablespoons
 - 8 tablespoons
 - 10 teaspoons
 - 11 teaspoons
 - 13 teaspoons
27. <7.6A> Find how many ounces there are in:
- 3 lb
 - 4 lb
 - 5 lb
 - 6 lb
 - 7 lb
28. <7.6A> Find how many pounds there are in:
- 16 oz
 - 24 oz
 - 32 oz
 - 40 oz
 - 48 oz
29. <7.6A> Find how many pounds there are in:
- 2 tons
 - 3 tons
 - 4 tons
 - 5 tons
 - 6 tons
30. <7.6A> Find how many tons there are in:
- 3000 lb
 - 5000 lb
 - 7000 lb
 - 9000 lb
 - 18,000 lb

31. **< 7.6B >** Find how many decigrams there are in:
- 1 dag
 - 3 dag
 - 5 dag
 - 4 dag
 - 2 dag
32. **< 7.6B >** Find how many grams there are in:
- 307 mg
 - 40 mg
 - 3245 mg
 - 2 mg
 - 10,342 mg
33. **< 7.6C >** Find how many pounds there are in:
- 1 kg
 - 7 kg
 - 6 kg
 - 4 kg
 - 8 kg
34. **< 7.6C >** Find how many kilograms there are in:
- 1 lb
 - 3 lb
 - 6 lb
 - 4 lb
 - 10 lb
35. **< 7.6D >** Find how many degrees Celsius there are in:
- 32°F
 - 41°F
 - 50°F
 - 59°F
 - 212°F
36. **< 7.6D >** Find how many degrees Fahrenheit there are in:
- 10°C
 - 15°C
 - 20°C
 - 25°C
 - 30°C

Practice Test Chapter 7

(Answers on pages 476)

Visit www.mhhe.com/bello to view helpful videos that provide step-by-step solutions to several of the problems below.

1. 5 yd = _____ in.
2. 4 in. = _____ ft
3. 25 ft = _____ yd
4. 10,560 ft = _____ mi
5. 3 ft = _____ in.
6. 5 km = _____ m
7. 5 dam = _____ m
8. 250 m = _____ dm
9. 482 cm = _____ m
10. 20 ft = _____ cm
11. 300 yd = _____ m
12. 40 mi = _____ km
13. 80 km = _____ mi
14. $6 \text{ m}^2 = \text{_____ cm}^2$
15. $432 \text{ in.}^2 = \text{_____ ft}^2$
16. Find the area in square yards of a 2-acre lot.
17. 3 hectares = _____ acres
18. 3 qt \approx _____ L
19. 3 kL = _____ L
20. 393 mL = _____ L
21. A cleaning solution contains $\frac{3}{4}$ cup of ammonia. How many mL is that?
22. A recipe calls for 400 mL of broth. How many cups is that?
23. A doctor orders 20 fluid oz of cough medicine. How many mL is that?
24. 6 lb = _____ oz
25. 64 oz = _____ lb
26. 4 tons = _____ lb
27. 7000 lb = _____ tons
28. 6 dag = _____ dg
29. 401 mg = _____ g
30. 5 kg = _____ lb
31. 5 lb = _____ kg
32. $59^\circ\text{F} = \text{_____ }^\circ\text{C}$
33. $10^\circ\text{C} = \text{_____ }^\circ\text{F}$

> Answers to Practice Test Chapter 7

Answer	If You Missed		Review	
	Question	Section	Examples	Page
1. 180	1	7.1	1	433
2. $\frac{1}{3}$	2	7.1	2, 3	434
3. $8\frac{1}{3}$	3	7.1	4	434
4. 2	4	7.1	5	434
5. 36	5	7.1	6	434
6. 5000	6	7.2	1	439
7. 50	7	7.2	3	440
8. 2500	8	7.2	2	440
9. 4.82	9	7.2	5	441
10. 609.6	10	7.3	1	445
11. 274.2	11	7.3	2	445
12. 64	12	7.3	3	445
13. 49.60	13	7.3	4–6	445–446
14. 60,000	14	7.4	1	451
15. 3	15	7.4	4	451
16. 9680 yd ²	16	7.4	6	452
17. 7.41	17	7.4	8	452
18. 3	18	7.5	1	456
19. 3000	19	7.5	2	457
20. 0.393	20	7.5	3	457
21. 180	21	7.5	4	457–458
22. $1\frac{2}{3}$	22	7.5	5	458
23. 600	23	7.5	6	458
24. 96	24	7.6	1	463
25. 4	25	7.6	2	463
26. 8000	26	7.6	3	463
27. $3\frac{1}{2}$	27	7.6	4	464
28. 600	28	7.6	5	464
29. 0.401	29	7.6	6	464
30. 11	30	7.6	7	465
31. 2.25	31	7.6	8	465
32. 15	32	7.6	9	466
33. 50	33	7.6	10	466

> Cumulative Review Chapters 1–7

1. Write two thousand, nine hundred ten in standard form.
2. Simplify: $4 \div 2 \cdot 2 + 9 - 7$
3. Write $\frac{31}{6}$ as a mixed number.
4. Write $4\frac{1}{3}$ as an improper fraction.
5. Subtract: $745.42 - 17.5$
6. Multiply: $0.503 \cdot 0.16$
7. Round 549.851 to the nearest tenth.
8. Divide: $50 \div 0.13$ (Round answer to two decimal digits.)
9. What decimal part of 12 is 3?
10. Solve for y : $1.6 = 0.4y$
11. Solve for z : $9 = \frac{z}{3.9}$
12. There is a law stating that “the ratio of width to length for the American flag should be 10 to 19.” Is a flag measuring 50 by 97 feet of the correct ratio?
13. Solve the proportion: $\frac{s}{3} = \frac{3}{27}$
14. The protein RDA for males is 60 grams per day. Three ounces of a certain product provide 4 grams of protein. How many ounces of the product are needed to provide 60 grams of protein?
15. Write 12% as a decimal.
16. Write $7\frac{1}{4}\%$ as a decimal.
17. 40% of 50 is what number?
18. What is $33\frac{1}{3}\%$ of 6?
19. What percent of 28 is 14?
20. 6 is 30% of what number?
21. Find the simple interest earned on \$500 invested at 8.5% for 5 years.
22. Referring to the circle graph, which is the main source of pollution?

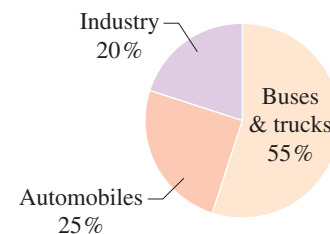

23. Make a circle graph for these data:

Family	Budget	(Monthly)
Savings	(S)	\$500
Housing	(H)	\$700
Food	(F)	\$400
Clothing	(C)	\$400

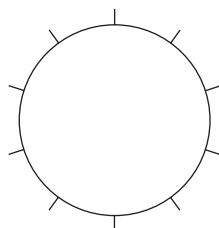

24. The following table shows the distribution of families by income in Tampa, Florida.

Income Level	Percent of Families
\$0–9,999	3
10,000–14,999	8
15,000–19,999	19
20,000–24,999	43
25,000–34,999	11
35,000–49,999	7
50,000–79,999	5
80,000–119,999	3
120,000 and over	1

What percent of the families in Tampa have incomes between \$20,000 and \$24,999?

- 25.** The following graph represents the yearly rainfall in inches in Sagamore County for 2000–2005. Find the rainfall for 2005.

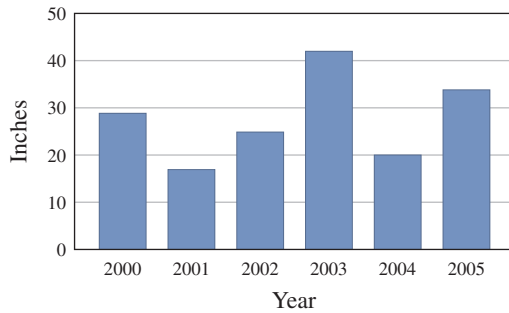

- 27.** The number of hours required in each discipline of a college core curriculum is represented by the following circle graph. What percent of these hours is in Math and English combined?

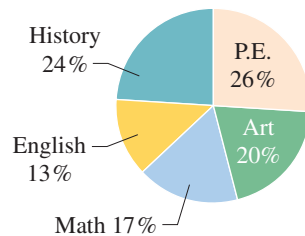

- 29.** What is the mean of the following numbers?
11, 3, 4, 12, 1, 7, 1, 25, 1, 22, 1
- 31.** Convert 12 yards to inches.
- 33.** Convert 47 feet to yards.
- 35.** Convert 8 feet to inches.
- 37.** Convert 5 dekameters to meters.
- 39.** Convert 50 yards to meters.
- 41.** Convert 100 kilometers to miles.
- 43.** Convert 6 hectares to acres.

- 26.** The following graph represents the monthly average temperature for 7 months of the year. How much higher is the average temperature in July than it is in May?

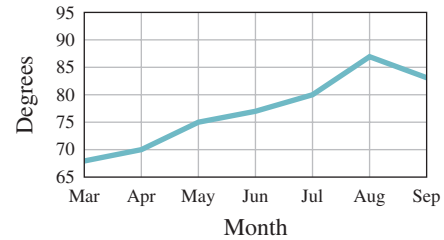

- 28.** What is the mode of the following set of numbers?
8, 11, 6, 12, 6, 10, 6, 24, 20, 23, 6

- 30.** What is the median of the following numbers?
6, 27, 25, 16, 27, 13, 27, 12, 27
- 32.** Convert 17 inches to feet.
- 34.** Convert 26,400 feet to miles.
- 36.** Convert 2 kilometers to meters.
- 38.** Convert 150 meters to decimeters.
- 40.** Convert 66 miles to kilometers.
- 42.** Find the area in square yards of a 4-acre lot.

Section

Chapter

- 8.1 Lines, Angles, and Triangles
- 8.2 Finding Perimeters
- 8.3 Finding Areas
- 8.4 Volume of Solids
- 8.5 Square Roots and the Pythagorean Theorem

8

eight

▶ Geometry

The Human Side of Mathematics

One of the most famous mathematicians of all time is Euclid, who taught in about 300 B.C. at the university in Alexandria, the main Egyptian seaport. Unfortunately, very little is known about Euclid personally; even his birthdate and birthplace are unknown. However, two stories about him have survived. One concerns the Emperor Ptolemy, who asked if there was no easy way to learn geometry and received Euclid's reply, "There is no royal road to geometry." The other story is about a student who studied geometry under Euclid and, when he had mastered the first theorem, asked, "But what shall I get by learning these things?" Euclid called a slave and said, "Give him a penny, since he must make gain from what he learns."

Geometry evolved from the more or less rudimentary ideas of the ancient Egyptians (about 1500 B.C.), who were concerned with practical problems involving the measurement of areas and volumes. The Egyptians were satisfied with the geometry that was needed to construct buildings and pyramids; they cared little about mathematical derivations or proofs of formulas. We shall follow that model in this chapter.

Euclid's greatest contribution was his collection and systemization of most of the Greek mathematics of his time. His reputation rests mainly on his work titled *The Elements*, which contains geometry, number theory, and some algebra. Most U.S. textbooks on plane and solid geometry essentially contain the same material in the geometry portions of Euclid's *The Elements*. No work, except the Bible, has been so widely used or studied, and probably no work has influenced scientific thinking more than this one. Over a thousand editions of *The Elements* have been published since the first printed edition appeared in 1482, and for more than 2000 years, this work has dominated the teaching of geometry.



8.1

Lines, Angles, and Triangles

▶ Objectives

You should be able to:

- A > Identify and name points, lines (parallel, intersecting, and perpendicular), segments, and rays.
- B > Name an angle three different ways.
- C > Classify an angle.
- D > Identify complementary angles and supplementary angles and find the complement or supplement of a given angle.
- E > Classify a triangle.
- F > Find the measure of the third angle, given the measures of two angles in a triangle.

▶ To Succeed, Review How To . . .

1. Add, subtract, multiply, and divide whole numbers. (pp. 24, 38, 50, 65)
2. Solve equations. (pp. 91–92, 251–252)

▶ Getting Started

The painting, *Blanc et Rouge/Composition in Red, Blue, and Yellow*, was painted by Piet Mondrian, a founder of the De Stijl art movement, which he left in 1923. Mondrian's own artistic theory was "Neoplasticism," a search for harmony and balance, which he pursued for the rest of his career. Neoplasticism used horizontal or vertical black lines of varied thickness to create a grid of planar rectangles, some of which were filled in with black or white, or vivid red, blue, or yellow. This characteristic abstract style expunged all reference to the real world ("Trees! How ghastly!" Mondrian said). In this section we shall study lines (parallel, perpendicular, and intersecting) like the ones in the painting. If you want to make your own painting using lines, squares, and rectangles, go to the paint machine at <http://www.composition-withjavascript.com>.

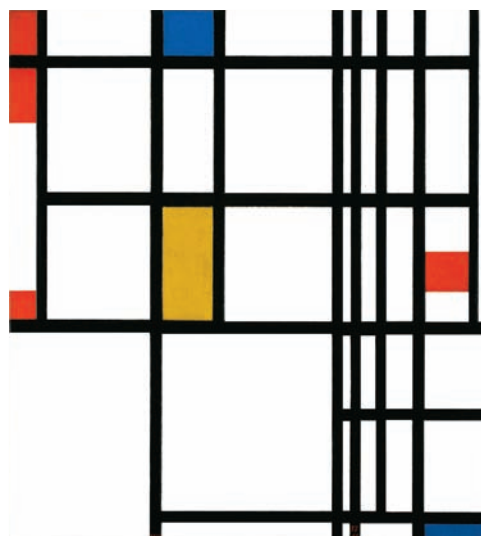

Mondrian, Piet (1872–1944)

Il: Blanc et Rouge (white and red), 1937/Composition in Red, Blue, and Yellow, 1937–42.

Oil on canvas, $23\frac{3}{4} \times 21\frac{7}{8}$ (60.3 × 55.4 cm).

© 2010 Mondrian/Holtzman Trust c/o HCR International Virginia

Digital Image © The Museum of Modern Art/Licensed by SCALA/Art Resource, NY

A > Points, Lines, and Rays

The word **geometry** is derived from the Greek words *geo* (earth) and *metron* (measure). The basic elements of geometry are **points**, **lines**, and **planes**.

A **point** can be regarded as a *location* in space. A point has no breadth, no width, and no length. We represent a *point* as a *dot* and label it with capital letters such as *A*, *B*, and *C* or *P*, *Q*, and *R* like this:



We can use points to make **lines**. A **line** is a set of points that extends *infinitely* in both directions. A line has no width or breadth, but it does have *length*. Lines are named with lowercase letters such as *l*, *m*, or *n* or by using two of the points on the line.



The arrowheads at each end of these lines signify that the line extends *infinitely* in each direction.

A piece of a line using *A* and *B* as endpoints is a **line segment** and is denoted by \overleftrightarrow{AB} .

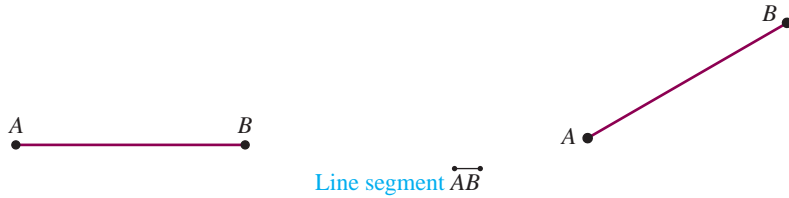

Lines that are on the same flat surface (*plane*) but never intersect (cross) are called **parallel lines**, while lines that intersect (cross) are called **intersecting lines**. The symbol \parallel is used to indicate that two lines are **parallel**.

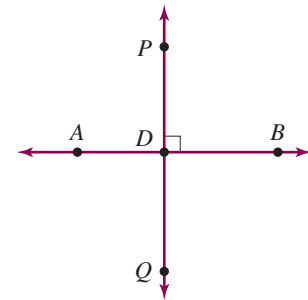
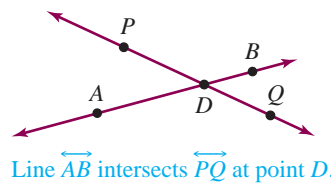
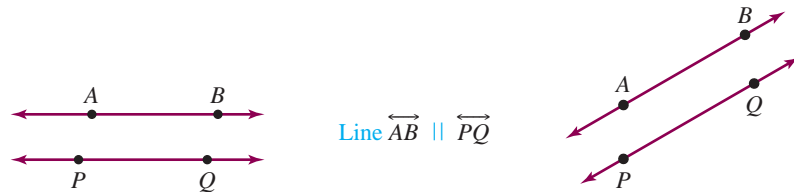

If the intersection is at right angles, the lines are **perpendicular** (\perp). Line $\overleftrightarrow{AB} \perp \overleftrightarrow{PQ}$.

A **ray** is part of a line with one *endpoint* and extending *infinitely* in one direction.

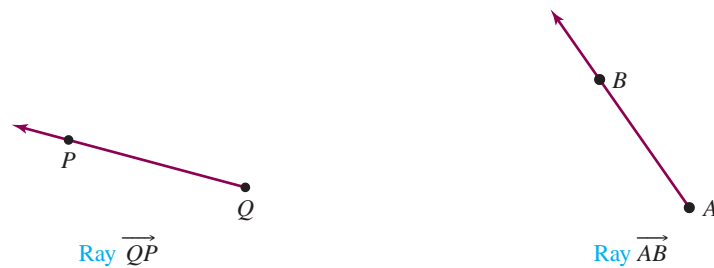

Note that the endpoint of ray \overrightarrow{QP} is *Q* and the endpoint of ray \overrightarrow{AB} is *A*.

B Naming Angles

The photo shows one of the many examples of ancient Hawaiian rock carvings (petroglyphs) at Waikoloa. These carvings contain images of the human figure varying in complexity from simple angular figures to triangular figures to muscular figures. How many angles do you see in the photo? How would you measure these angles?



Have you heard the expression, “I am looking at it from a new angle”? In geometry, an angle is the figure formed by two sides with a common point called the vertex. Here is the definition.

ANGLE

An angle is the figure formed by two rays (sides) with a common endpoint called the vertex.

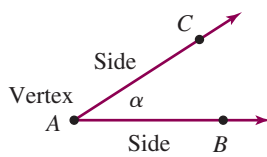

The two rays \overrightarrow{AB} and \overrightarrow{AC} are called the **sides** of the angle. We use the symbol \angle (read “angle”) in naming angles. Thus, the angle in the figure can be named $\angle\alpha$ (angle alpha), $\angle BAC$, or $\angle CAB$. (Note that the middle letter designates the vertex.)

The angle in the margin can be named in the following three ways:

1. By using a letter or a number inside the angle. Thus, we would name the angle $\angle\alpha$ (read “angle alpha”).
2. By using the vertex letter only, such as $\angle A$.
3. By using three letters, one from each ray, with the vertex letter in the middle. The angle would be named $\angle BAC$ or $\angle CAB$.

Table 8.1 summarizes the concepts we have discussed and introduces the idea of a plane.

Table 8.1



Concept	Name	Notation
A point shows a location. • <i>P</i>	Point <i>P</i>	<i>P</i>
A line extends infinitely in both directions. 	Line <i>AB</i>	\overleftrightarrow{AB}
	Plane <i>ABC</i>	<i>ABC</i>
Three points determine a plane .		

Table 8.1 (continued)

Concept	Name	Notation
<p>The line segment AB includes the endpoints A and B and all points between A and B.</p> 	Segment AB	\overline{AB}
<p>The line AB is parallel to the line PQ.</p> 	Line AB is parallel to line PQ .	$\overleftrightarrow{AB} \parallel \overleftrightarrow{PQ}$
<p>The line AB is perpendicular to the line PQ. The green symbol indicates that the lines AB and PQ intersect at a 90° angle.</p> 	Line AB is perpendicular to line PQ .	$\overleftrightarrow{AB} \perp \overleftrightarrow{PQ}$
<p>The ray AB extends infinitely in one direction starting at endpoint A and going through point B.</p> 	Ray AB	\overrightarrow{AB}

EXAMPLE 1 Naming geometric figures

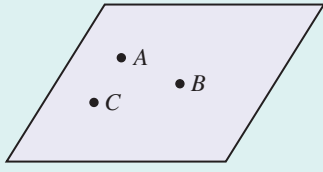
Refer to the figure and identify

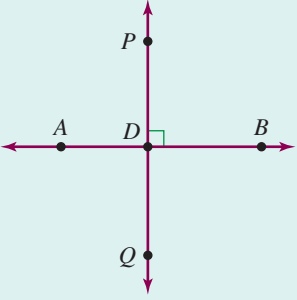
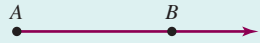
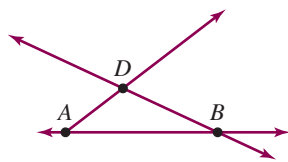

- a. Three points.
- b. Two lines.
- c. Three line segments.
- d. A pair of intersecting lines.
- e. A ray.

SOLUTION 1

- a. The three points in the figure are A , B , and D .
- b. There are two lines in the figure: line \overleftrightarrow{AB} and line \overleftrightarrow{BD} . (You can also call \overleftrightarrow{BD} line \overleftrightarrow{DB} .)

PROBLEM 1

Refer to the figure and identify

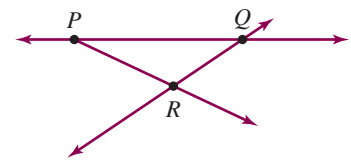

- a. Three points.
- b. Two lines.
- c. Three line segments.
- d. A pair of intersecting lines.
- e. A ray.

(continued)

Answers to PROBLEMS

1. a. P, Q, R b. $\overleftrightarrow{PQ} = \overleftrightarrow{QP}$ and $\overleftrightarrow{RQ} = \overleftrightarrow{QR}$ c. $\overleftrightarrow{PQ}, \overleftrightarrow{PR},$ and \overleftrightarrow{RQ} d. \overleftrightarrow{PQ} and \overleftrightarrow{RQ} intersect e. \overleftrightarrow{PR}

- c. \overrightarrow{AB} , \overrightarrow{AD} , and \overrightarrow{DB}
- d. Lines \overrightarrow{AB} and \overrightarrow{BD} intersect.
- e. There is only one ray in the figure: \overrightarrow{AD} (its endpoint is at A and it goes through point D).

EXAMPLE 2 Naming angles and vertices

Consider the angle in the figure shown here.

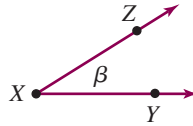

- a. Name the angle in three different ways.
- b. Name the vertex of the angle.
- c. Name the sides of the angle.

SOLUTION 2

- a. The angle can be named $\angle\beta$ (Greek letter beta), $\angle X$, or $\angle YXZ$ (or $\angle ZXY$).
- b. The vertex is the point X .
- c. The sides are the rays \overrightarrow{XZ} and \overrightarrow{XY} .

PROBLEM 2

Name the angle shown in three different ways.

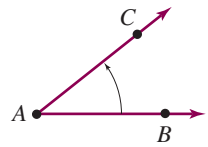
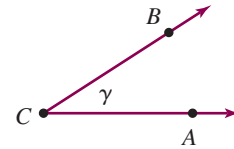

>Figure 8.1

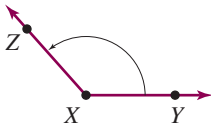

C > Classifying Angles

For most practical purposes, we need to have a way of measuring angles. We first consider the amount of **rotation** needed to turn one side of an angle so that it *coincides with* (falls exactly on top of) the other side. Figure 8.1 shows two angles, $\angle CAB$ and $\angle ZXY$, with curved arrows to indicate the rotation needed to turn the rays \overrightarrow{AB} and \overrightarrow{XY} so that they coincide with the rays \overrightarrow{AC} and \overrightarrow{XZ} , respectively. Clearly, the amount needed for $\angle ZXY$ is greater than that for $\angle CAB$. To find how much greater, we have to measure the amounts of rotation.

The most common unit of measure for an angle is the *degree*. We can trace the degree system back to the ancient Babylonians, who used a base 60 system of numeration. The Babylonians considered a *complete revolution* of a ray as indicated in Figure 8.2, and divided that into 360 equal parts. Each part is **1 degree**, denoted by 1° . Thus, a complete revolution is equal to 360° . One-half of a complete revolution is 180° and gives us an angle that is called a **straight angle** (see Figure 8.3). One-quarter of a complete revolution is 90° and gives a **right angle** (see Figure 8.4). Notice the small square at Y to denote that it is a right angle.

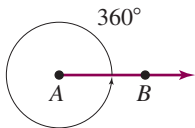

>Figure 8.2 A complete revolution.

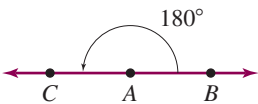

>Figure 8.3 The straight angle CAB .

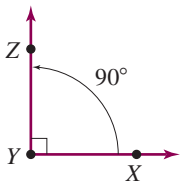

>Figure 8.4 The right angle XYZ .

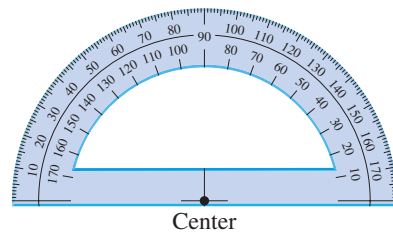

>Figure 8.5 A protractor.

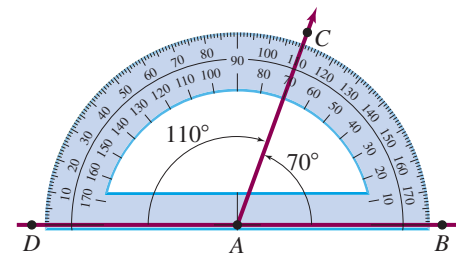

>Figure 8.6 Measuring an angle.

Answers to PROBLEMS

- 2. $\angle\gamma$, $\angle C$, $\angle ACB$ (or $\angle BCA$)

We have already named two angles: a *straight angle* (180°) and a *right angle* (90°). Certain other angles are classified as follows:

TYPES OF ANGLES

An **acute angle** is an angle of measure *greater than* 0° and *less than* 90° .

An **obtuse angle** is an angle of measure *greater than* 90° and *less than* 180° .

We can summarize this discussion by classifying angles according to their measurement. Here is the way we do it:

TYPES OF ANGLES

Right angle: An angle whose measure is 90° .

Straight angle: An angle whose measure is 180° .

Acute angle: An angle whose measure is *greater than* 0° and *less than* 90° .

Obtuse angle: An angle whose measure is *greater than* 90° and *less than* 180° .

Here are some examples:

The following angles are all acute angles (between 0° and 90°):

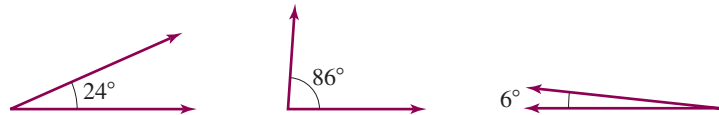

The following angles are all obtuse angles (between 90° and 180°):

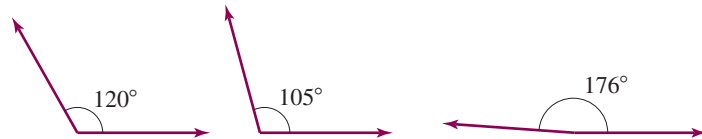

EXAMPLE 3 Classifying angles

Classify the given angles.

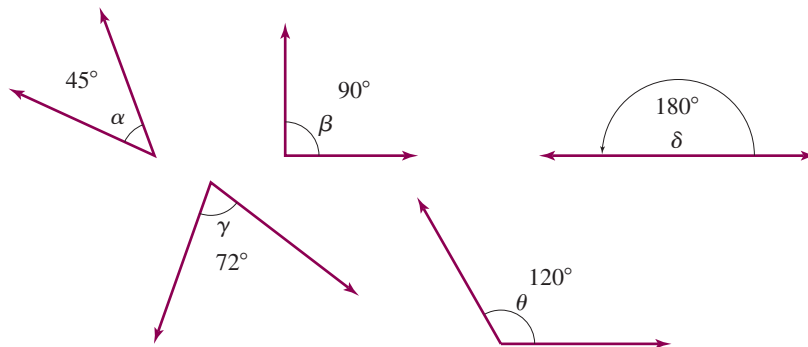

SOLUTION 3

α is between 0° and 90° ; it is an acute angle.

β is exactly 90° ; it is a right angle.

δ (delta) is exactly 180° ; it is a straight angle.

γ (gamma) is between 0° and 90° ; it is an acute angle.

θ (theta) is between 90° and 180° ; it is an obtuse angle.

PROBLEM 3

Classify the given angles.

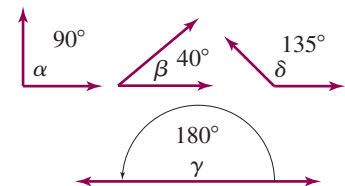

Answers to PROBLEMS

3. α is a right angle, β is an acute angle, δ is an obtuse angle, and γ is a straight angle.

EXAMPLE 4 Classifying angles: Solar eclipse angles

Why do we have solar eclipses (when the moon blocks the sun from view)? It is because the angle subtended (taken up) by the sun (0.52° to 0.54°) and the moon (0.49° to 0.55°) are almost identical. Classify these angles.

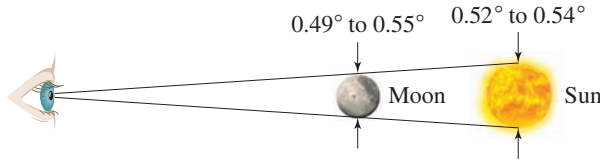

Source: National Aeronautics and Space Administration.

SOLUTION 4 All the angles are actually smaller than one degree, so all of them are acute angles.

PROBLEM 4

The diagram shows the path of a satellite from noon to 12:03 PM. Classify angles γ , β , and δ .

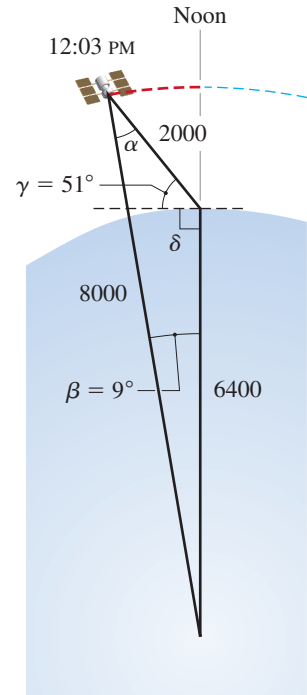

D > Complementary and Supplementary Angles

How far is the leg from being vertical, that is, how much is it bending? The answer can be obtained by measuring angle α . As you can see the sum of the measures of angles θ and α is 90° . This makes angles θ and α **complementary** angles. Here is the definition.

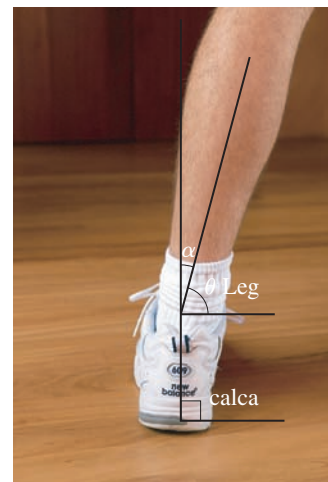

COMPLEMENTARY ANGLES

Complementary angles are two angles whose sum is 90° .* If $\angle A$ and $\angle B$ are complementary, $m\angle A + m\angle B = 90^\circ$ or, equivalently, $m\angle A = 90^\circ - m\angle B$.

In the following figure, $m\angle A = 60^\circ$ and $m\angle B = 30^\circ$, so $m\angle A + m\angle B = 60^\circ + 30^\circ = 90^\circ$. Thus, $\angle A$ and $\angle B$ are *complementary* angles.

Note that $m\angle A = 90^\circ - m\angle B$.

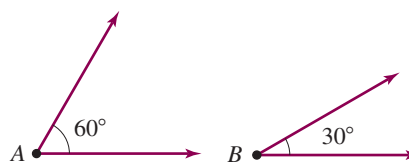

Answers to PROBLEMS

4. γ is an acute angle, β is an acute angle, and δ is a right angle.

*Technically, the **sum** of their **measures** is 90° .

SUPPLEMENTARY ANGLES

Supplementary angles are two angles whose sum is 180° .* If $\angle A$ and $\angle B$ are supplementary, $m\angle A + m\angle B = 180^\circ$ or, equivalently, $m\angle A = 180^\circ - m\angle B$.

In the next figure, $m\angle A = 130^\circ$ and $m\angle B = 50^\circ$, so $m\angle A + m\angle B = 180^\circ$. Thus, $\angle A$ and $\angle B$ are *supplementary* angles.

Note that $m\angle A = 180^\circ - m\angle B$.



EXAMPLE 5 Identifying complementary angles

Identify all complementary angles in the figure.

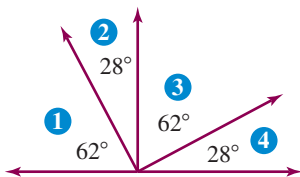

SOLUTION 5 $\angle 1$ and $\angle 2$; $\angle 2$ and $\angle 3$; $\angle 3$ and $\angle 4$; $\angle 1$ and $\angle 4$.

PROBLEM 5

Identify all complementary angles in the figure.

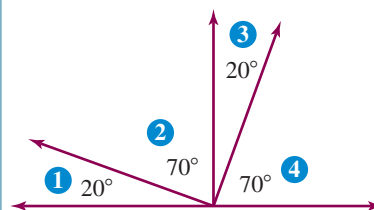

EXAMPLE 6 Finding the complement of an angle

Find the measure of the complement of a 50° angle.

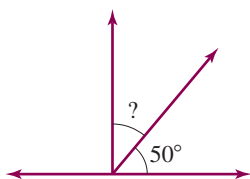

SOLUTION 6 The measure of the complement of a 50° angle is $90^\circ - 50^\circ = 40^\circ$.

CHECK $50^\circ + 40^\circ = 90^\circ$.

PROBLEM 6

Find the measure of the complement of a 30° angle.

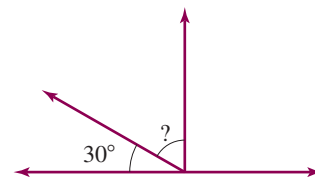

EXAMPLE 7 Finding the supplement of an angle

Find the measure of the supplement of angle 1.

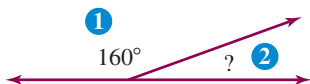

SOLUTION 7 Since $\angle 1$ and $\angle 2$ are supplementary and $m\angle 1 = 160^\circ$, $m\angle 2 = 180^\circ - 160^\circ = 20^\circ$.

CHECK $160^\circ + 20^\circ = 180^\circ$.

PROBLEM 7

Find the measure of the supplement of angle 2.

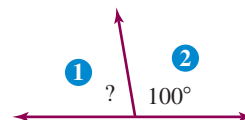

*Technically, the sum of their measures is 180° .

Answers to PROBLEMS

5. $\angle 1$ and $\angle 2$; $\angle 2$ and $\angle 3$; $\angle 3$ and $\angle 4$; $\angle 1$ and $\angle 4$ 6. 60° 7. 80°

E> Triangles

Now that we know how to work with angles, we expand our studies to triangles (literally, three angles). What is the most famous triangle you know? It is probably the Bermuda Triangle, a 1.5-million-mile triangular area of open sea with vertices at Miami, Bermuda, and Puerto Rico. What kind of a triangle is the Bermuda triangle? Certainly a mysterious

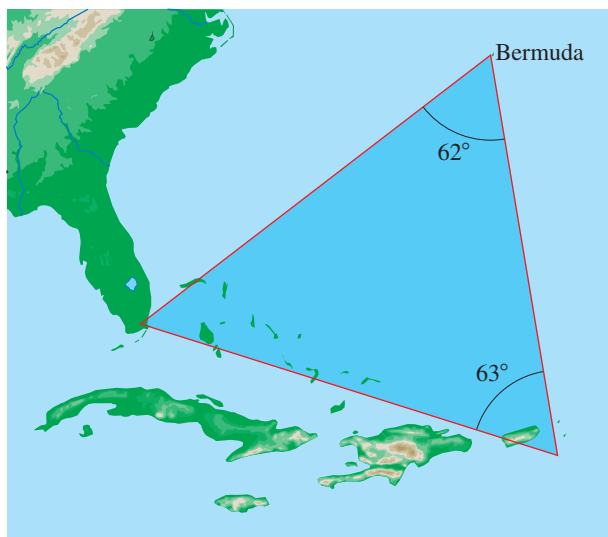

one, but as far as geometry is concerned, triangles are classified according to their angles or the number of equal sides. Here are the classifications:

CLASSIFYING TRIANGLES BY THEIR ANGLES

Right triangle: A triangle containing a *right* angle

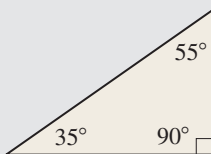

Acute triangle: A triangle in which all the angles are *acute*

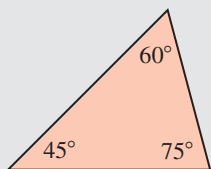

Obtuse triangle: A triangle containing an *obtuse* angle



CLASSIFYING TRIANGLES BY THEIR SIDES

Scalene triangle: A triangle with *no* equal sides (Note that the sides are labeled I, II, and III to show that the lengths of the sides are different.)

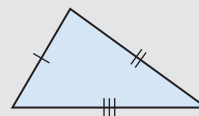

Isosceles triangle: A triangle with *two* equal sides

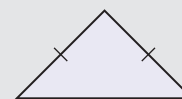

Equilateral triangle: A triangle with *all* three sides equal

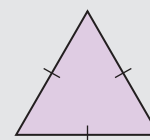

As you can see, all three angles in the Bermuda triangle are acute, so the triangle is an acute triangle. In addition, no two sides have the same length, that is, there are no equal sides, which makes it a scalene triangle. We can then say that the Bermuda triangle is an acute, scalene triangle. Triangles are named using their vertices. Thus, the triangle with vertices A , B , and C is named $\triangle ABC$, and the triangle with vertices P , Q , and R is named $\triangle PQR$.

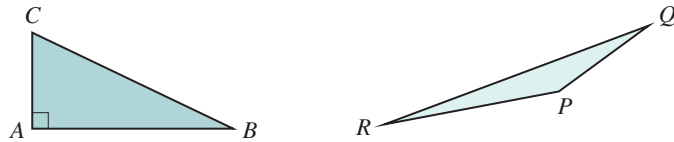

EXAMPLE 8 Classifying triangles

Classify the given triangles according to their angles and their sides.

a.

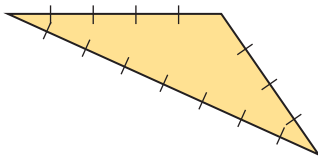

b.

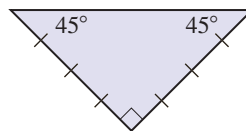

c.

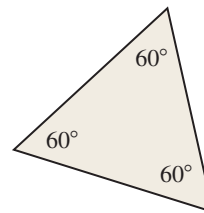

SOLUTION 8

- The triangle has an *obtuse* angle and *no* equal sides; it is an *obtuse, scalene* triangle.
- The triangle has *two* equal sides and a *right* angle; it is an *isosceles, right* triangle.
- The triangle has three 60° angles; it is an *equilateral* triangle, which is also *equiangular*.

PROBLEM 8

Classify the given triangles according to their angles and their sides.

a.

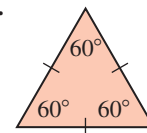

b.

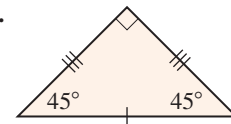

c.

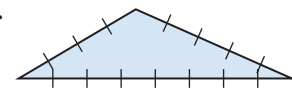

F> Sum of the Angles of a Triangle

What do you notice about the sum of the measure of the angles of the triangles in Example 8, $45^\circ + 45^\circ + 90^\circ$ and $60^\circ + 60^\circ + 60^\circ$? The sum is 180° . This is always the case!

Here is a way to show this. Cut a triangle out of a sheet of paper as shown in the following figure. Label the angles 1, 2, and 3 and cut them off the triangle. Place the vertices of angles 1, 2, and 3 together. Now two of the sides form a straight line!

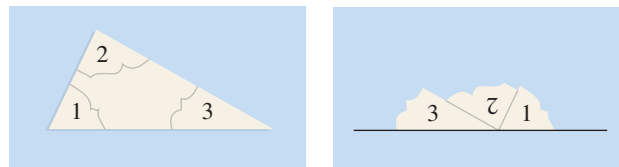

Thus, we have shown the following:

SUM OF THE MEASURES OF THE ANGLES IN A TRIANGLE

The sum of the measure of the three angles in any triangle is 180° .

Answers to PROBLEMS

8. a. Equilateral, equiangular triangle b. Isosceles, right triangle c. Obtuse, scalene triangle

EXAMPLE 9 Finding the measure of an angle in a triangle

In a triangle ABC , $m\angle A = 47^\circ$, $m\angle B = 59^\circ$. Find $m\angle C$.

SOLUTION 9

Since $m\angle A + m\angle B + m\angle C = 180^\circ$

$$\begin{aligned} m\angle C &= 180^\circ - m\angle A - m\angle B \\ &= 180^\circ - 47^\circ - 59^\circ \\ &= 180^\circ - 106^\circ \\ &= 74^\circ \end{aligned}$$

Thus, $m\angle C = 74^\circ$.

PROBLEM 9

Find the third angle for the Bermuda Triangle shown on page 488.

Are you using your math skills to improve the environment? At Barnard College the students in the waste management class investigated the placement of their recycling receptacles and determined that 5% of the students were **never** able to find them, 45% could **sometimes** find them, and 50% could **always** find them. To draw an accurate pie chart of the data they had to determine the angles needed to make the pie chart. How did they do that? As is shown in Example 10!

Source: http://issuu.com/barnard/docs/solid_waste_management.

GREEN MATH

EXAMPLE 10 Pie charts for availability of recycling bins

The chart detailing the data regarding the availability of recycling bins is shown below. Each of the sections shows an angle α , β , or γ .

- What type of angle is α ? What is its measure?
- What type of angle is β ? What is its measure?
- What type of angle is γ ? What is its measure?

Ability to Find Appropriate Recycling Receptacle on Campus

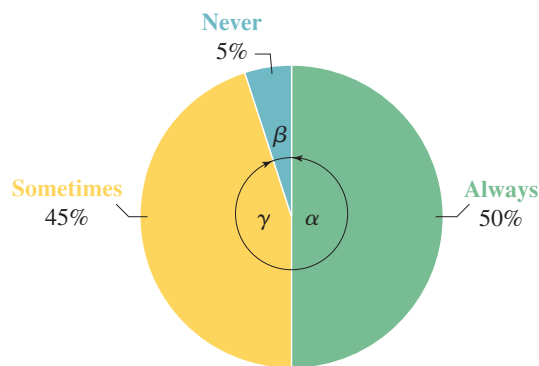
**SOLUTION 10**

- α is a **straight angle** measuring 180° (half of a revolution).
- β is an **acute angle** whose measure is more than 0° and less than 90° . The measure of β is 5% of 360° (a revolution), that is, $0.05 \cdot 360^\circ = 18^\circ$.
- γ is an **obtuse angle**, and its measure is 45% of $360^\circ = 0.45 \cdot 360$ or 162° .

PROBLEM 10

The chart shows three angles α , β , and γ .

- What type of angle is α ? What is its measure?
- What type of angle is β ? What is its measure?
- What type of angle is γ ? What is its measure?

Students Perception of Who Believe There Are Adequate Recycling Receptacles on Campus?

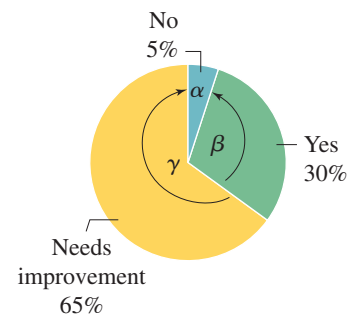
**Answers to PROBLEMS**

9. $180^\circ - 62^\circ - 63^\circ = 55^\circ$

10. **a.** α is an acute angle measuring 18° . **b.** β is an obtuse angle measuring 108° . **c.** γ is an obtuse angle measuring 234° .



- > Practice Problems
- > Self-Tests
- > Media-rich eBooks
- > e-Professors
- > Videos

> Exercises 8.1

< A > Points, Lines, and Rays In Problems 1–10, identify and name each figure as a *line*, *line segment*, *ray*, *parallel lines*, *intersecting lines*, or *perpendicular lines*.

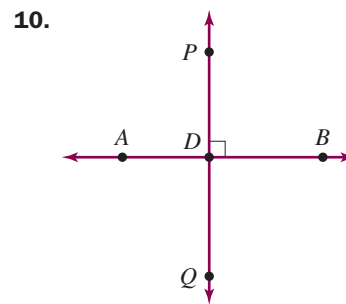
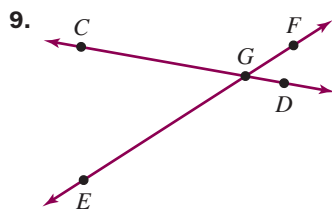
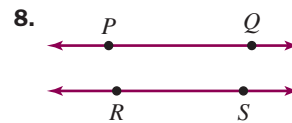
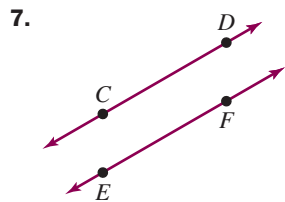
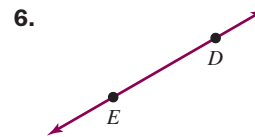

< B > Naming Angles In Problems 11 and 12, name the angle in three different ways.

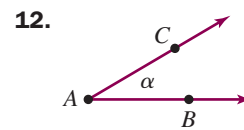
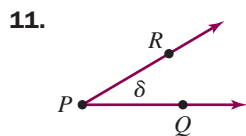

For Problems 13–16, refer to Figure 8.7.

13. Name $\angle \alpha$ in another way.

14. Name $\angle EAF$ in another way.

15. Name $\angle \beta$ in another way.

16. Name $\angle CAB$ in another way.

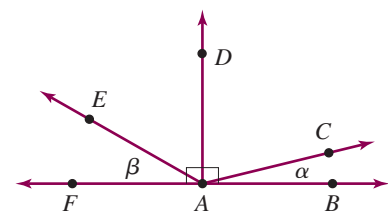

Figure 8.7



< C > Classifying Angles In Problems 17–22, classify the given angle in Figure 8.7.

- | | | |
|--|---|------------------|
| 17. $\angle\alpha$ | 18. $\angle\beta$ | 19. $\angle DAB$ |
| 20. $\angle DAF$ | 21. $\angle FAB$ | 22. $\angle BAF$ |
| 23. List all the right angles in Figure 8.7. | 24. List all the obtuse angles in Figure 8.7. | |
| 25. Name one straight angle in Figure 8.7. | | |

< D > Complementary and Supplementary Angles For Problems 26–36, refer to Figure 8.7.

- | | |
|---|--|
| 26. Name the complement of $\angle\alpha$. | 27. Name the complement of $\angle\beta$. |
| 28. Name an angle that is the complement of $\angle EAF$. | 29. Name an angle that is the complement of $\angle BAC$. |
| 30. Name an angle that is supplementary to $\angle\alpha$. | 31. Name an angle that is supplementary to $\angle\beta$. |
| 32. Name an angle that is supplementary to $\angle BAD$. | 33. If $m\angle\alpha = 15^\circ$, find $m\angle CAD$. |
| 34. If $m\angle\beta = 55^\circ$, find $m\angle DAE$. | 35. If $m\angle DAE = 35^\circ$, find $m\angle\beta$. |
| 36. If $m\angle CAD = 75^\circ$, find $m\angle\alpha$. | |

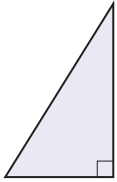
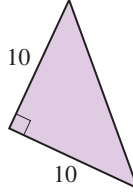
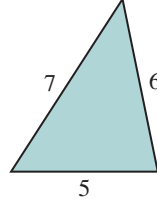
< E > Triangles In Problems 37–44, classify the triangle as scalene, isosceles, or equilateral and acute, right, or obtuse.

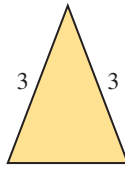
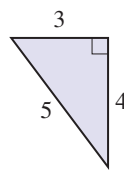
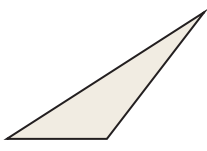
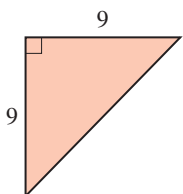
- | | | |
|---|---|---|
| 37.  | 38.  | 39.  |
| 40.  | 41.  | 42.  |
| 43.  | 44.  | |

< F > Sum of the Angles of a Triangle In Problems 45–50, find the measure of the missing angle.

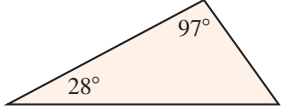
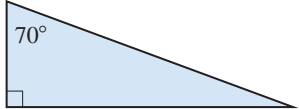
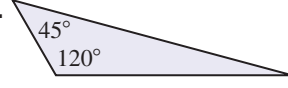
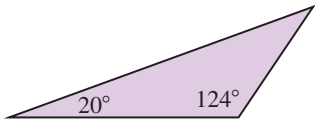
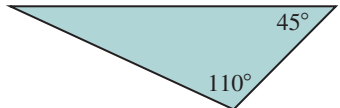
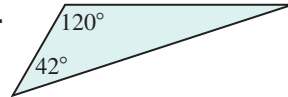
- | | | |
|---|---|---|
| 45.  | 46.  | 47.  |
| 48.  | 49.  | 50.  |

- | | |
|--|---|
| 51. In a triangle ABC , $m\angle A = 37^\circ$ and $m\angle C = 53^\circ$. Find $m\angle B$. | 52. In a triangle ABC , $m\angle B = 67^\circ$ and $m\angle C = 105^\circ$. Find $m\angle A$. |
|--|---|

Applications

Angles Classify the angles shown in the photos as acute, obtuse, or right.

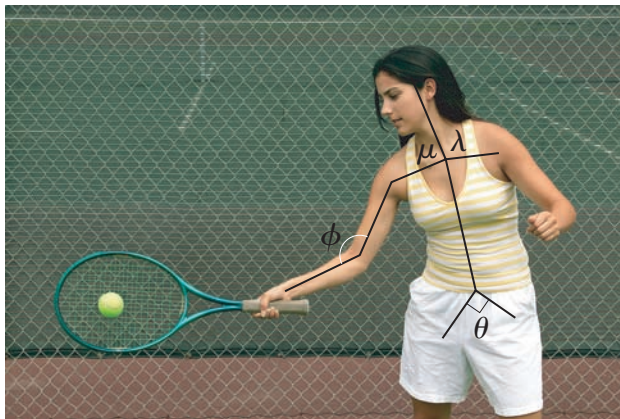
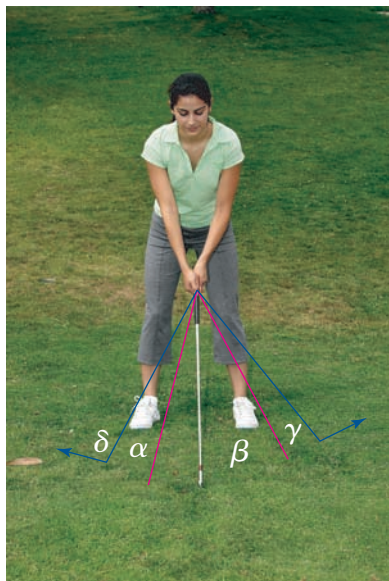

53. Classify $\angle\alpha$.

56. Classify $\angle\delta$.

59. Classify $\angle\mu$.

54. Classify $\angle\beta$.

57. Classify $\angle\phi$.

60. Classify $\angle\theta$.

55. Classify $\angle\gamma$.

58. Classify $\angle\lambda$.

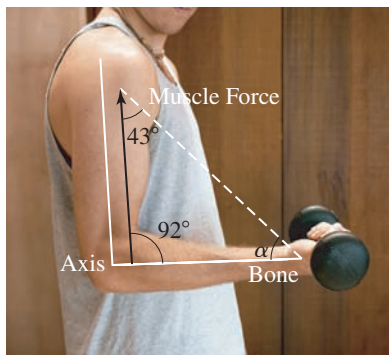

61. What is the measure of angle α ? (left figure above)

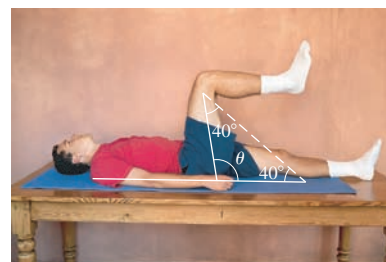

62. What is the measure of angle θ ? (right figure above)

Angles and triangles For Problems 63–66, refer to the rock art drawing.

63. Classify angles α and β .

64. Classify angles δ and ε .

65. The body of the rock carving is in the shape of a triangle. Classify the triangle.

66. If the triangle is an isosceles triangle and the two equal angles are 62° , what is the measure of β ?



>>> **Applications: Green Math**

Electric sources for energy in the United States and the United Kingdom.

67. Energy sources for electric power In the United States, the three primary energy sources for generating electric power are coal, natural gas, and nuclear energy with each contributing the percent shown in the chart below.

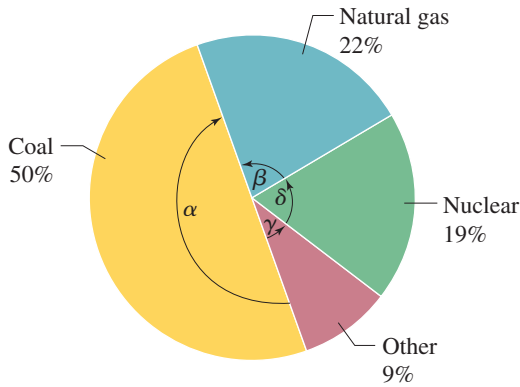

Source: http://www.eia.doe.gov/cneaf/electricity/epa/epa_sum.html.

- What type of angle is α ? What is its measure?
- What type of angle is β ? What is its measure?
- What type of angle is δ ? What is its measure?
- What type of angle is γ ? What is its measure?

68. Renewable sources used to generate electricity In the United Kingdom, the renewable sources used to generate electricity are as shown in the pie chart.

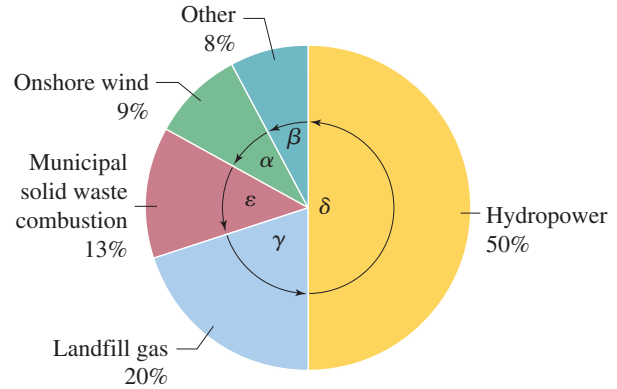

Source: http://www.ace.mmu.ac.uk/Resources/Fact_Sheets/Key_Stage_4/Energy/02.html.

- What type of angle is δ ? What is its measure?
- What type of angle is β ? What is its measure?
- What type of angle is α ? What is its measure?
- What type of angle is ϵ ? What is its measure?
- What type of angle is γ ? What is its measure?

>>> **Using Your Knowledge**

Parallel Lines and a Transversal Line We have studied parallel lines, intersecting lines, and angles. Let us use our knowledge to generalize these ideas. What happens when a line intersects a pair of parallel lines?

A line that intersects a pair of parallel lines is called a **transversal**. In the figure, lines L_1 and L_2 are parallel and line L_3 is a transversal.

Think of $\angle 1$ as a “small angle” and $\angle 2$ as a “big angle”

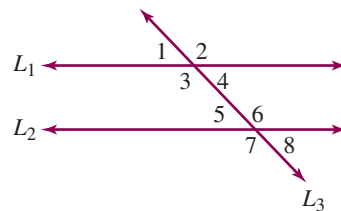

There is a special rule in geometry (the *Transversal Postulate*) that involves angles and transversals. It says that if two parallel lines are intersected by a transversal, then the corresponding angles are congruent (equal), denoted by using the symbol \cong .

Corresponding angles (angles on the same side of the transversal) are **congruent**.

$$m\angle 1 \cong \angle 5, \quad \angle 3 \cong \angle 7, \quad \angle 2 \cong \angle 6, \quad \text{and} \quad \angle 4 \cong \angle 8$$

Alternate interior angles (pairs of angles between the parallel lines and on opposite sides of the transversal) are **congruent**.

$$m\angle 3 \cong \angle 6, \quad \text{and} \quad \angle 4 \cong \angle 5$$

Vertical angles are congruent.

$$m \angle 1 \cong \angle 4, \quad \angle 2 \cong \angle 3, \quad \angle 5 \cong \angle 8, \quad \text{and} \quad \angle 6 \cong \angle 7$$

Do you have to memorize all this? Absolutely not!

Think of $\angle 1$ as “a **small** angle” and $\angle 2$ as “a **big** angle.” Here is the summary:

All **small** angles are equal.

All **big** angles are equal.

Now, do you remember adding apples and apples, and bananas and bananas? Let’s apply the postulate to the fruits shown in the picture. Which angles are congruent (equal)?

If the two horizontal lines are parallel, all “**small**” angles (cherry, lemon, and strawberry) are congruent (have the same measure). By the way, if the angle represented by the cherry is 60° , then the angle represented by the cantaloupe must be 120° , since those two angles (cherry and cantaloupe) are supplementary angles. Can you name the rest of the angles that are congruent (equal)? (*Hint: All the “big” angles are equal.*)

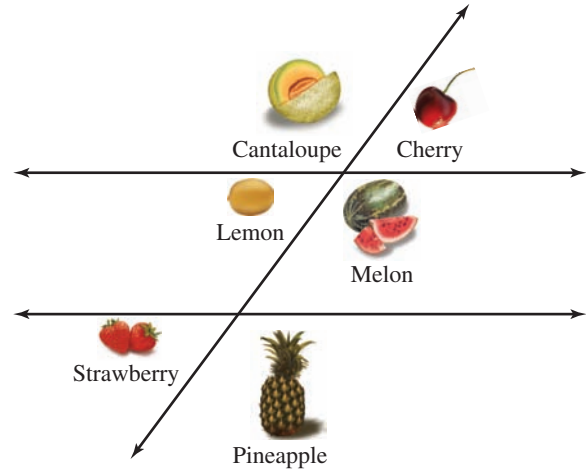

Lines L_1 and L_2 are parallel and L_3 is a transversal

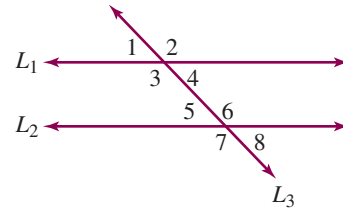

Lines L_1 and L_2 are parallel and L_3 is a transversal

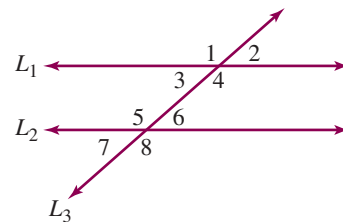

The figure will be used in Problems 69–70.

- 69. Assume that $m \angle 2 = 135^\circ$. What is $m \angle 1$?
- 70. If $m \angle 2$ is a “big” angle, list all the angles that are congruent to $\angle 2$.

The figure will be used in Problems 71–72.

- 71. Assume that $m \angle 2 = 42^\circ$. What is $m \angle 1$?
- 72. If $m \angle 2$ is a “small” angle, list all the angles that are congruent to $\angle 2$.

Music The graph shows the music preferences of young adults 14–19. Each of the sections in the circle (pie) graph forms an angle with the center of the circle.

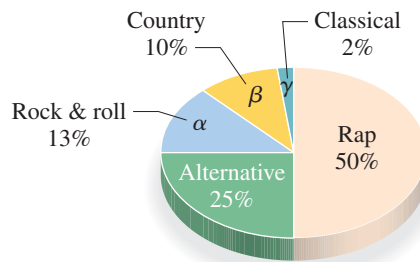

Source: Statistics Canada.

73. Which section shows a straight angle?
74. Which section shows a right angle?
75. How many sections show acute angles?
76. A complete circle covers 360° . The straight angle is 50% of 360° . How many degrees is that?
77. The right angle covers 25% of 360° . How many degrees is that?
78. Use the percents given in the graph to find $m\angle\alpha$.
79. Use the percents given in the graph to find $m\angle\beta$.
80. Use the percents given in the graph to find $m\angle\gamma$.

>>> Write On

81. Write in your own words the difference between a line and a ray.
82. You can actually measure the length of a line segment. Can you measure the length of a line? Explain.
83. Can you measure the length of a ray? Explain
84. If the length of a ray is given by the letter r and the length of a line is given by the letter L , what symbol would you write ($=$, $<$, $>$) to make this statement true: r ___ L ? Explain your reasoning.
85. Write in your own words the type of angle you need when you want to use the phone on the right.
86. How many degrees would that angle be when the phone is closed?
87. What angle do you think is best for viewing the screen on the phone? Explain.



>>> Concept Checker

Fill in the blank(s) with the correct word(s), phrase, or mathematical statement.

88. A _____ shows a **location**.
89. A _____ extends **infinitely** in both directions.
90. A line _____ includes its **endpoints**.
91. To denote that the line AB is **parallel** to the line CD , we use the symbol _____.
92. A _____ extends **infinitely** in one direction.
93. An _____ is the figure formed by **two rays** with a **common endpoint**.
94. A _____ angle is an angle whose **measure is 90°** .
95. A _____ angle is an angle whose **measure is 180°** .
96. An _____ angle is an angle whose measure is **greater than 0° and less than 90°** .
97. An _____ angle is an angle whose measure is **greater than 90° and less than 180°** .
98. _____ angles are two angles whose **sum is 90°** .
99. _____ angles are two angles whose **sum is 180°** .
100. The **sum** of the measure of the **three angles** in a triangle is _____.

straight

line

Supplementary

angle

ray

point

acute

segment

||

90°

Complementary

180°

right

obtuse

\perp

>>> Mastery Test

The figure will be used in Problems 101–105.

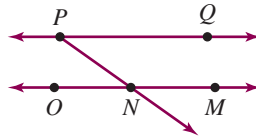

- 101.** Name three points in the figure.
- 102.** Name two lines in the figure.
- 103.** Name three line segments in the figure.
- 104.** Which pair of lines appears to be parallel in the figure?
- 105.** Name a ray in the figure.
- 106.** In triangle ABC , $m\angle A = 50^\circ$, $m\angle B = 30^\circ$. Find $m\angle C$.
- 107.** Classify each of the triangles according to its angles and its sides.

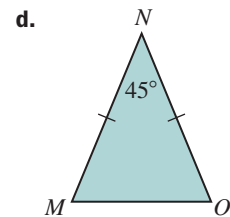
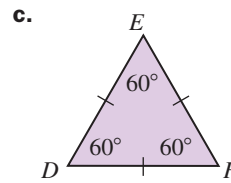
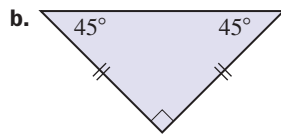
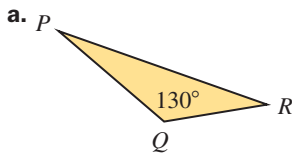

- 108.** Find the measure of the complement of the 70° angle shown.

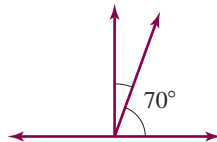

- 109.** Find the measure of the supplement of the 35° angle shown.

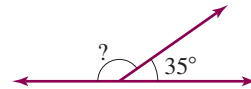

- 110.** Classify the given angles.

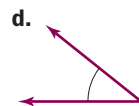

- 111.** Name the angle in three different ways.

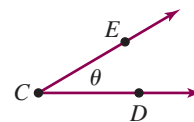

>>> Skill Checker

In Problems 112–116, evaluate the expression.

112. $3.14 \cdot 100$

113. $2 \cdot 5.1 + 2 \cdot 3.2$

114. $2 \cdot 400 + 2 \cdot 500$

115. $4 \cdot 3\frac{1}{4}$

116. $5 \cdot 921$

8.2 Finding Perimeters

Objectives

You should be able to:

- A > Find the perimeter of a polygon.
- B > Find the circumference of a circle.
- C > Solve applications involving the concepts studied.

To Succeed, Review How To . . .

1. Multiply decimals and fractions. (pp. 135–137, 222–224)
2. Add decimals and fractions. (pp. 157–161, 212–214)

Getting Started

Suppose you want to build a fence around the lot. How many linear feet of fencing do you need? To answer this question we need to find the *perimeter* (distance around) of the lot by adding the lengths of the sides. (The symbol ['] means feet and ["] means inches.) The perimeter is:

$$(439 + 180 + 534 + 293) \text{ ft, or } 1446 \text{ ft}$$



A > Finding Perimeters

In general, the **perimeter** is the distance around an object.

PERIMETER OF A POLYGON

The **perimeter of a polygon** is the sum of the lengths of the sides.
 Note: In a **regular polygon** all sides are of equal length.

Table 8.2 will give you an idea of the shapes and names of some of the polygons we will study.

Table 8.2

A **regular polygon** is a polygon with all *sides of equal length* and all *angles of equal measure*. They are usually named by using the *number* of sides. For example,

- A **triangle** is a **3-sided** polygon.
- Quadrilateral** is a **4-sided** polygon.
- Pentagon** is a **5-sided** polygon.
- Hexagon** is a **6-sided** polygon.
- Heptagon** is a **7-sided** polygon.
- Octagon** is an **8-sided** polygon.
- Nonagon** is a **9-sided** polygon.
- Decagon** is a **10-sided** polygon.

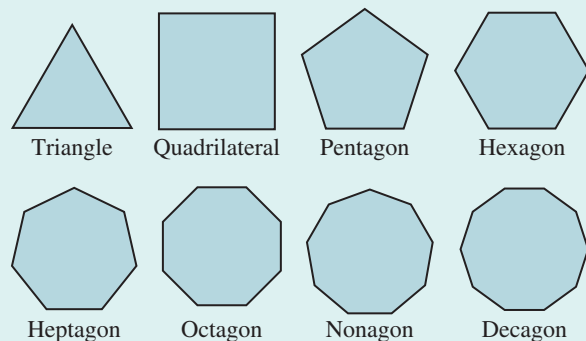

All of these are regular polygons.

Table 8.2 (continued)

A **trapezoid** is a quadrilateral with exactly one pair of opposite sides parallel.



Trapezoid

A **parallelogram** is a quadrilateral in which the opposite sides are parallel and equal.

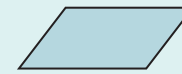

Parallelogram

A **rhombus** is a parallelogram with all sides equal in length.

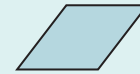

Rhombus

A **rectangle** is a parallelogram with four right angles.



Rectangle

A **square** is a rectangle with all sides equal in length.



Square

Now, we are ready to find the perimeter of some of these polygons.

EXAMPLE 1 Perimeter of a polygon

Find the perimeter of the polygon.

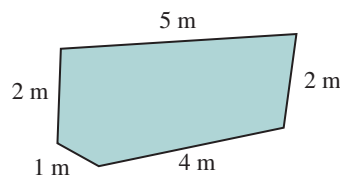

SOLUTION 1 The perimeter is

$$(1 + 2 + 5 + 2 + 4) \text{ m} = 14 \text{ m}$$

PROBLEM 1

Find the perimeter of the polygon.

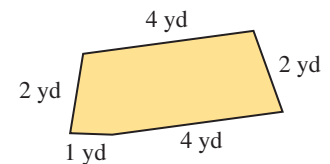
**EXAMPLE 2** Perimeter of a rectangle

Find the perimeter of the rectangle.

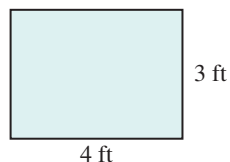

SOLUTION 2 The perimeter is

$$(4 + 3 + 4 + 3) \text{ ft} = 14 \text{ ft}$$

PROBLEM 2

Find the perimeter of the rectangle.

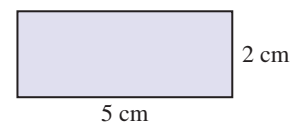
**Answers to PROBLEMS**

1. 13 yd 2. 14 cm

Note that in Example 2 we added the length twice and the width twice because a rectangle has two pairs of sides with equal length. Here is the formula:

PERIMETER OF A RECTANGLE

The **perimeter** P of a rectangle is twice the length L plus twice the width W , that is,

$$P = 2 \cdot L + 2 \cdot W$$

EXAMPLE 3 Perimeter of a rectangle

Find the perimeter of a rectangle 5.1 centimeters long by 3.2 centimeters wide.

SOLUTION 3

$$\begin{aligned} P &= (2 \cdot 5.1 + 2 \cdot 3.2) \text{ cm} \\ &= (10.2 + 6.4) \text{ cm} \\ &= 16.6 \text{ cm} \end{aligned}$$

PROBLEM 3

Find the perimeter of a rectangle 6.3 inches long by 3.4 inches wide.

EXAMPLE 4 Perimeter of a square

Find the perimeter of the square.

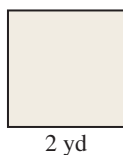

SOLUTION 4

The perimeter is

$$(2 + 2 + 2 + 2) \text{ yd} = 8 \text{ yd}$$

PROBLEM 4

Find the perimeter of the square.



To find the perimeter of the square in Example 4 we added the length of the side four times because all four sides of a square have equal length. Here is the formula:

PERIMETER OF A SQUARE

The **perimeter** P of a square is four times the length of its side S , that is,

$$P = 4 \cdot S$$

EXAMPLE 5 Perimeter of a square

Find the perimeter of the square.

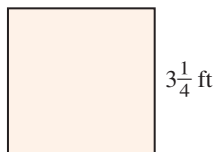

SOLUTION 5

The perimeter is

$$\begin{aligned} P &= 4 \cdot 3\frac{1}{4} \text{ ft} \\ &= 4 \cdot \frac{13}{4} \text{ ft} \\ &= 13 \text{ ft} \end{aligned}$$

PROBLEM 5

Find the perimeter of the square.

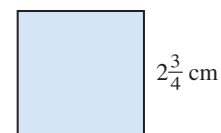

Answers to PROBLEMS

3. 19.4 in. 4. 12 m 5. 11 cm

EXAMPLE 6 Perimeter of the Pentagon

Each of the outermost sides of the Pentagon building in Arlington, Virginia, is 921 feet long. What is the perimeter of this building?

SOLUTION 6 A pentagon has five sides, as shown. Thus, the perimeter of the building is $5 \cdot 921 \text{ ft} = 4605 \text{ ft}$.

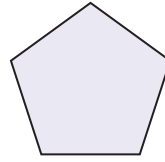
**PROBLEM 6**

Find the perimeter of the pentagon.

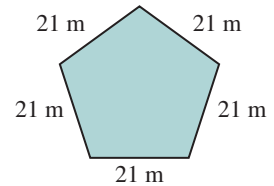
**B > Finding Circumferences**

You are probably familiar with the geometric figure called a circle. The distance around a circle is called the *circumference*. The figure shows a circle with center O . The line segment AB is called the **diameter**, d , and OC is called the **radius**, r . The radius connects the **center** of the circle to a point on the **edge** of the circle, while the diameter connects two points on the **edge** of the circle passing through the **center**. Note that, in general,

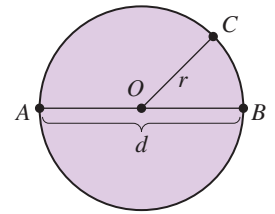
**RELATIONSHIP BETWEEN DIAMETER d AND RADIUS r**

$$d = 2 \cdot r \quad \text{and} \quad r = \frac{d}{2}$$

This means that the diameter d is always twice the radius r , and the radius r is half the diameter. Thus, if the diameter of a circle is 8 inches, the radius is half of that, or 4 inches. Also, if the radius of a circle is 3 centimeters, its diameter is twice that, or 6 centimeters. Now, suppose you measure the circumference C and the diameter d of a soda can. If you divide C by d , the ratio $\frac{C}{d}$ is very close to 3.14159 (The three dots mean the decimal continues.) If we find the ratio $\frac{C}{d}$ for different sized cans, the answer continues to be close to 3.14159 As a matter of fact, for any circle, we symbolize the ratio of $\frac{C}{d}$ by the letter π (pi, read “pie”)—that is, $\frac{C}{d} = \pi$. Multiplying on both sides by d gives $d \cdot \frac{C}{d} = d \cdot \pi$, or $C = \pi \cdot d$. Thus,

CIRCUMFERENCE OF A CIRCLE

The **circumference** C of a circle of radius r equals two times π times the radius r or π times the diameter d . In symbols,

$$C = 2\pi r \quad \text{or} \quad C = \pi d$$

Note: π is approximately 3.14 or $\frac{22}{7}$.

EXAMPLE 7 Finding the circumference

Find the circumference of a circle whose radius is 4 centimeters. Use 3.14 for π .

SOLUTION 7 Since the radius is 4 centimeters, the diameter is twice that, or 8 centimeters. The circumference is

$$\begin{aligned} C &= \pi \cdot d \\ &= 3.14 \cdot 8 \text{ cm} \\ &= 25.12 \text{ cm} \end{aligned}$$

PROBLEM 7

Find the circumference of a circle whose radius is 5 feet. Use 3.14 for π .

Answers to PROBLEMS

6. 105 m 7. 31.4 ft

C > Applications Involving Perimeter and Circumference

EXAMPLE 8 Distance traveled by Venus

The planet Venus revolves around the sun in a nearly circular orbit whose diameter is about 100 million kilometers. Find the distance traveled by Venus in one revolution around the sun. Use 3.14 for π .

SOLUTION 8 The distance traveled is the circumference C .

$$\begin{aligned} C &= \pi \cdot d \\ &= 3.14 \cdot 100 \text{ million kilometers} \\ &= 314 \text{ million kilometers} \end{aligned}$$

PROBLEM 8

Mars's orbit about the sun is approximately a circle 200 million kilometers in diameter. Find the distance traveled by Mars in one revolution around the sun. Use 3.14 for π .

GREEN MATH

EXAMPLE 9 Measuring perimeter to make a compost bin

Suppose you want to construct a compost bin like the one shown. How much 30-in.-high wire mesh do you need?

SOLUTION 9 We have to find the perimeter of the 40 in. by 42 in. bin. Since the perimeter P of a rectangle is $P = 2L + 2W$ the perimeter is

$$P = 2(40) + 2(42) = 80 \text{ in.} + 84 \text{ in.} = 164 \text{ in.}$$

Thus, you need 164 inches of wire mesh 30 inches high.

You can cut down on the amount of garbage you generate by composting organic waste such as dead leaves and food scraps!

PROBLEM 9

How much wire mesh 30 inches high do you need to make a 50 in. by 52 in. bin?

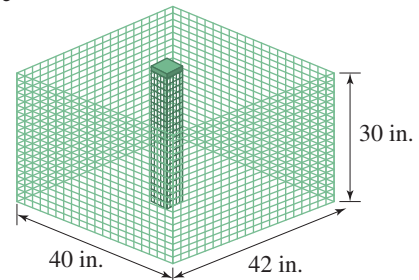

Source: <http://tinyurl.com/mjokgl>.

> Exercises 8.2



> Practice Problems > Self-Tests
> Media-rich eBooks > e-Professors > Videos

< **A** > **Finding Perimeters** In Problems 1–20, find the perimeters of the polygons.

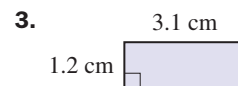
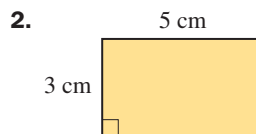
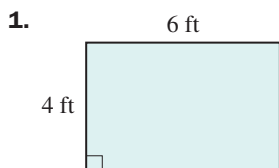

Answers to PROBLEMS

8. 628 million kilometers

9. 204 in.

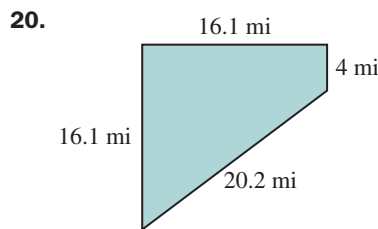
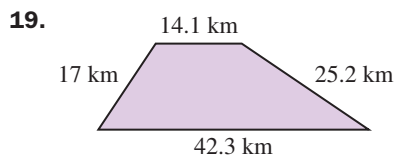
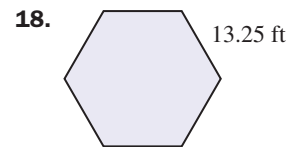
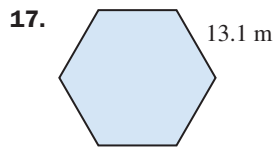
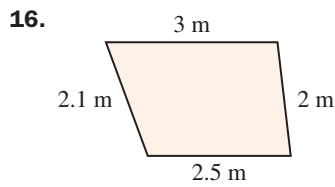
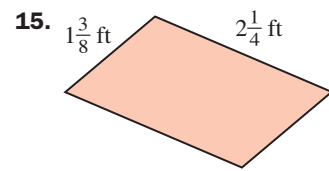
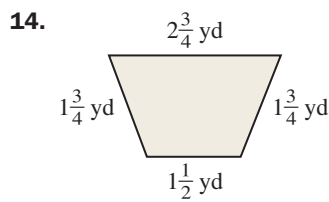
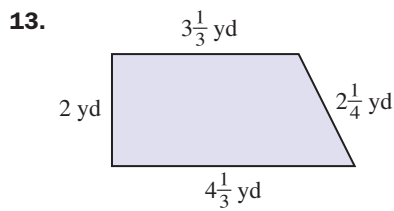
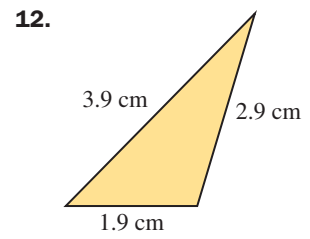
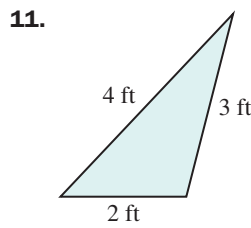
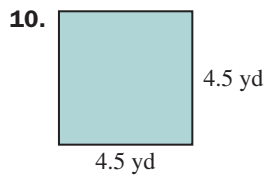
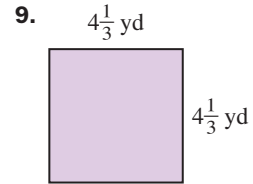
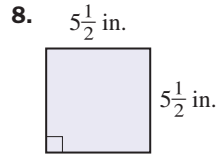
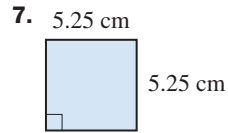
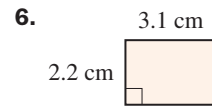
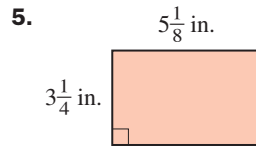
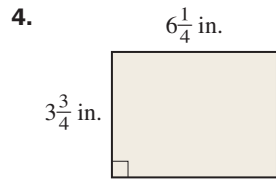

< B > Finding Circumferences In Problems 21–28, find the circumference (use 3.14 for π).

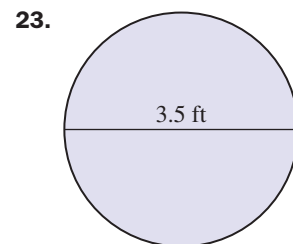
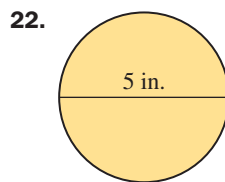
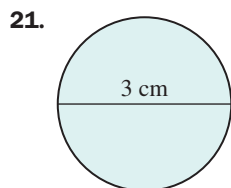

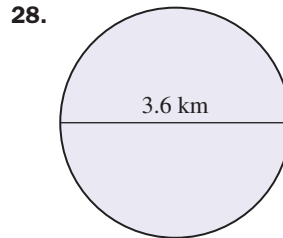
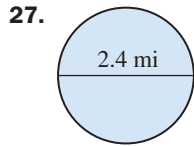
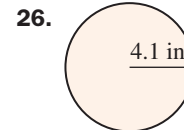
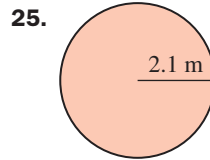
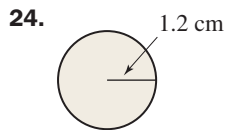

< C > Applications Involving Perimeter and Circumference

29. *Perimeter of largest pool* The largest pool in the world is in Casablanca, Morocco, and it is 480 meters long and 75 meters wide. What is the perimeter of this pool?
30. *Perimeter of VAB* The rectangular Vehicle Assembly Building (VAB) at Cape Canaveral is 716 feet long and 518 feet wide. What is the perimeter of this building?
31. *Perimeter of largest drydock* The largest drydock is Okopo No. 1 in South Korea. The rectangular structure is 1772.4 feet long by 430 feet wide. How many feet do you have to walk to cover the perimeter of this drydock?
32. *Poster perimeter* One of the largest posters was made in Japan and measured 328 feet by 328 feet. How many feet of frame were required to frame this poster?
33. *Framing the Mona Lisa* The *Mona Lisa*, a painting by Leonardo da Vinci, measures 30.5 inches by 20.9 inches. How many inches of frame (measured on the inside) were needed to frame the painting?
34. *Baseball diamond* A baseball diamond is actually a square. If the distance to first base is 90 feet, how far do you have to run to cover all bases?
35. *Circumference of bicycle tire* The diameter of a bicycle tire is 60 centimeters. What is the circumference of the tire? Use 3.14 for π .
36. *Clock hand movement* The minute hand of a clock is 3 inches long. How far does the tip of the hand move in 1 hour? Use 3.14 for π .

>>> Applications: Green Math

Making compost bins

37. Suppose you want to make a compost bin (see Example 9) with wire mesh 48 inches high and measuring 60 in. by 70 in. How many inches of wire mesh 48 inches high do you need?
38. How many inches of wire mesh 36 inches high do you need to make a compost bin (see Example 9) 50 inches wide and 60 inches long?
39. How many inches of wire mesh 36 inches high do you need to make a circular compost bin 30 inches in diameter? Use 3.14 for π .
40. How many inches of wire mesh 36 inches high do you need to make a circular compost bin 48 inches in diameter? Use 3.14 for π .

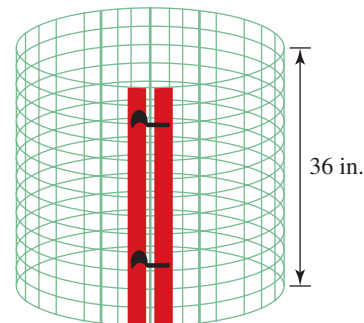

Photo Source: <http://www.digitalseed.com/composter/bins/wirebin.html>.

Using Your Knowledge

Distance Traveled If you are traveling by car, the distance between two points is shown on travel maps.

41. Find the distance traveled when going from Laredo to San Antonio to Del Rio and back to Laredo.
42. Find the distance traveled when going from Dallas to Houston to Shreveport and back to Dallas.
43. Find the distance traveled when starting at Austin, driving to Ft. Worth, then to Abilene, and back to Austin.



Write On

44. Do you remember the Distributive Property from Chapter 1? In this section, we mentioned that the perimeter P of a rectangle is $P = 2L + 2W$. Use the Distributive Property to write this formula in a different way.
45. A rectangle is 20 meters by 10 meters. Discuss three different ways in which you can find the perimeter. Which is the fastest?

Concept Checker

Fill in the blank(s) with the correct word(s), phrase, or mathematical statement.

46. The _____ of a polygon is the **sum of the lengths** of its sides.
47. The _____ of a **circle** of diameter d is πd .

perimeter

volume

area

circumference

Mastery Test

48. Find the perimeter of a rectangular recreation area measuring 200 feet by 100 feet.
49. Jupiter's orbit around the sun is approximately a circle with an 800-million-kilometer diameter. Find the distance traveled by Jupiter in one revolution around the sun. Use 3.14 for π .
50. A pentagonal building is constructed so that each of its sides is 700 feet long. What is the perimeter of this building?
51. Find the perimeter of a square whose side is $5\frac{1}{4}$ centimeters.
52. Find the perimeter of the square shown.
53. Find the perimeter of a rectangle 3.4 centimeters long by 1.2 centimeters wide.

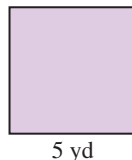

54. Find the perimeter of the rectangle.



55. Find the perimeter of the polygon.

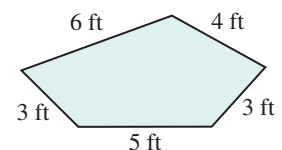

Skill Checker

Multiply.

56. $\frac{1}{2} \cdot 15 \cdot 10$

57. $\frac{1}{2} \cdot 15 \cdot 20$

58. $\frac{1}{2} \cdot 13 \cdot 8$

59. $\frac{1}{2} \cdot 3 \cdot 5$

60. $\frac{1}{2} \cdot 9 \cdot 7$

8.3

Finding Areas

▶ Objectives

You should be able to:

- A > Find the area of a rectangle or square.
- B > Find the area of a triangle.
- C > Find the area of a parallelogram.
- D > Find the area of a trapezoid.
- E > Find the area of a circle.

▶ To Succeed, Review How To . . .

Multiply fractions and decimals. (pp. 135–137, 222–224)

▶ Getting Started

The picture shows some fish in an aquarium. Do you know how many fish you can have living in an aquarium? The approximate number can be found by estimating the *area* of the water on the surface. If the aquarium is 20 inches long by 10 inches wide, as shown below, the area of the water surface is

$$10 \text{ in.} \cdot 20 \text{ in.} = 200 \text{ in.}^2 \quad (\text{read "200 square inches"})$$

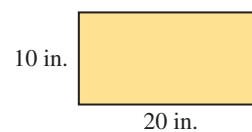

A > Areas of Rectangles and Squares

In the metric system the **area** of a square 1 centimeter on each side is

$$1 \text{ cm} \cdot 1 \text{ cm} = 1 \text{ cm}^2 \quad (\text{read "one square centimeter"})$$

Note that we treat the dimension symbol, the centimeter, as if it were a number. Thus,

$$\text{cm} \cdot \text{cm} = \text{cm}^2$$

$$\text{in.} \cdot \text{in.} = \text{in.}^2$$

Similarly, in the customary system we can define the area of a square 1 in. on each side as

$$1 \text{ in.} \cdot 1 \text{ in.} = 1 \text{ in.}^2$$

These two areas are shown in the following illustration.

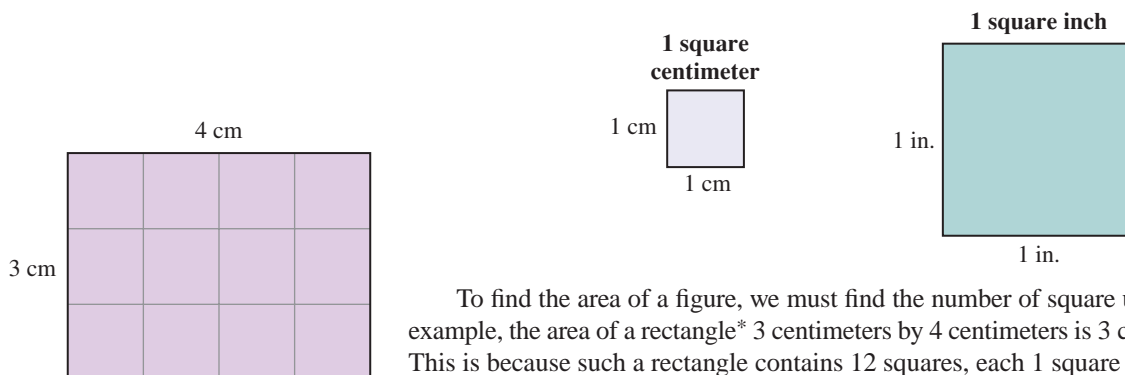

To find the area of a figure, we must find the number of square units it contains. For example, the area of a rectangle* 3 centimeters by 4 centimeters is $3 \text{ cm} \cdot 4 \text{ cm} = 12 \text{ cm}^2$. This is because such a rectangle contains 12 squares, each 1 square centimeter.

*A rectangle is a four-sided polygon in which the opposite sides are parallel and which has four 90° angles.

In general, you can find the area of any rectangle by multiplying its length L by its width W , as shown.

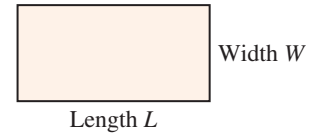

AREA OF A RECTANGLE

The area A of a rectangle is the product of its length L and its width W . In symbols,

$$A = L \cdot W$$

EXAMPLE 1 Area of a rectangle

Find the area of a rectangle 6 meters by 4 meters.

SOLUTION 1 $A = L \cdot W = (6 \text{ m}) \cdot (4 \text{ m}) = 24 \text{ m}^2$

Thus the area of the rectangle is 24 square meters.

PROBLEM 1

Find the area of a rectangle 5 yards by 8 yards.

The area of a square is easier to find because length and width are the same. For example, if a square has a side of length S , its area is $S \cdot S = S^2$.

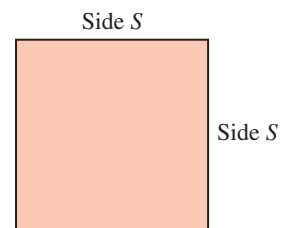

AREA OF A SQUARE

The area A of a square is the square of its side S . In symbols,

$$A = S \cdot S = S^2$$

EXAMPLE 2 Area of a square

Find the area of a square whose side is 6 inches long.

SOLUTION 2 $A = S^2 = S \cdot S$
 $= (6 \text{ in.}) \cdot (6 \text{ in.}) = 36 \text{ in.}^2$

PROBLEM 2

Find the area of a square whose side is 8 centimeters long.

B > Area of a Triangle

If we know the area of a rectangle, we can always find the area of a triangle. Look at the following figure and see if you can find the formula for the area of the triangle.

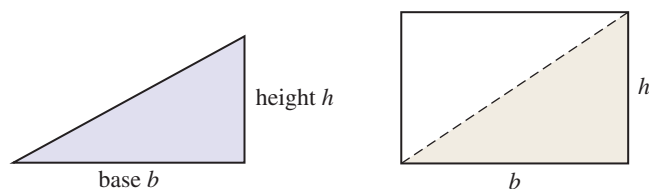

Since the area of the triangle (shaded) is $\frac{1}{2}$ the area of the rectangle, which is bh , the area of the triangle is $\frac{1}{2}bh$.

AREA OF A TRIANGLE

The area A of a triangle is the product of $\frac{1}{2}$ its base b by its height h . In symbols,

$$A = \frac{1}{2} \cdot b \cdot h$$

Answers to PROBLEMS

1. 40 yd² 2. 64 cm²

This formula holds true for any type of triangle.

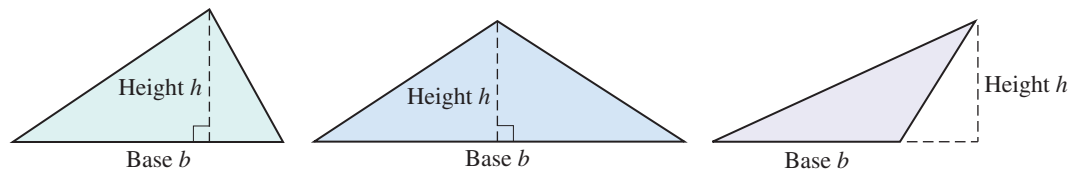

EXAMPLE 3 Area of a triangle

Find the area of a triangular piece of cloth 15 centimeters long and 10 centimeters wide.

SOLUTION 3

$$A = \frac{1}{2} \cdot 15 \text{ cm} \cdot 10 \text{ cm} = \frac{1}{2} \cdot 15 \text{ cm} \cdot \overset{5}{10} \text{ cm} = 75 \text{ cm}^2$$

PROBLEM 3

Find the area of a triangular piece of metal 12 inches high and 10 inches long.

C > Area of a Parallelogram

If you know the area of a rectangle, you can find the area of a **parallelogram**, a four-sided figure with two pairs of parallel sides. Here are some parallelograms.

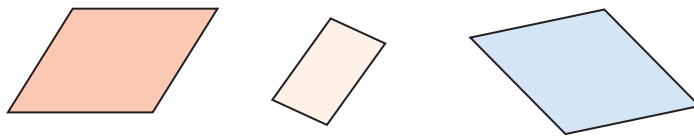

To find the area of the following parallelogram, we cut the triangular piece and move it to the other side, obtaining a rectangle. Since the area of the rectangle is the length times the width, the area A of the parallelogram is $b \cdot h$.

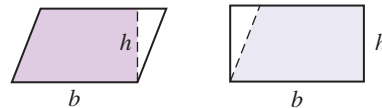

AREA OF A PARALLELOGRAM

The area A of a parallelogram is the product of its base b times its height h . In symbols,

$$A = b \cdot h$$

EXAMPLE 4 Area of a parallelogram

Find the area of the parallelogram.

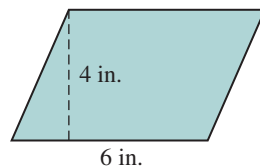

SOLUTION 4

$$\begin{aligned} A &= (6 \text{ in.}) \cdot (4 \text{ in.}) \\ &= 24 \text{ in.}^2 \end{aligned}$$

PROBLEM 4

Find the area of the parallelogram.

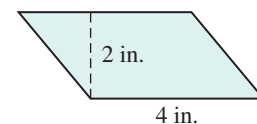

Answers to PROBLEMS

3. 60 in.² 4. 8 in.²

D > Area of a Trapezoid

A **trapezoid** is a four-sided figure that has exactly one pair of parallel sides. Here are some trapezoids.

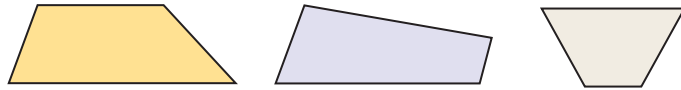

To find the area of a trapezoid, we construct another just like it and place the two together to form a parallelogram.

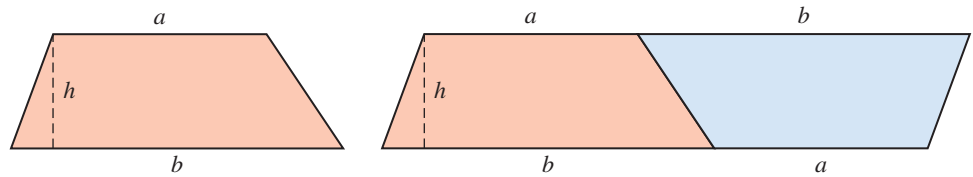

The area of the parallelogram is the length of the base ($a + b$) times the height (h), or $h \cdot (a + b)$; however, the area of the trapezoid is one-half the area of the parallelogram or $\frac{1}{2}(a + b)h$.

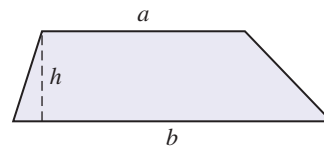

AREA OF A TRAPEZOID

The area A of a trapezoid is $\frac{1}{2}$ times the sum of the length of the bases ($a + b$) and its height h . In symbols,

$$A = \frac{1}{2} \cdot (a + b) \cdot h$$

EXAMPLE 5 Area of a trapezoid

Find the area of the trapezoid.

SOLUTION 5

$$\begin{aligned} A &= \frac{1}{2} \cdot (4 \text{ cm}) \cdot (5 \text{ cm} + 6 \text{ cm}) \\ &= \frac{1}{2} \cdot (4 \text{ cm}) \cdot (11 \text{ cm}) \\ &= \frac{4 \cdot 11}{2} \text{ cm}^2 \\ &= 22 \text{ cm}^2 \end{aligned}$$

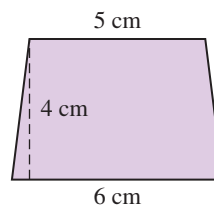

PROBLEM 5

Find the area of the trapezoid

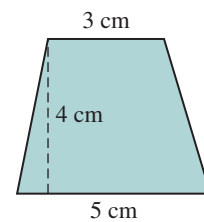

E > Area of a Circle

The area of a circle can be found if we know the distance from the center of the circle to its edge, the radius r , of the circle. The formula for finding the area of a circle also involves the number π , which we approximate by 3.14 or $\frac{22}{7}$.

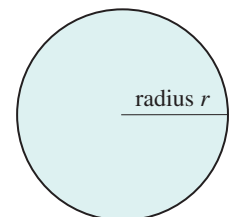

Answers to PROBLEMS

5. 16 cm^2

AREA OF A CIRCLE

The area A of a circle is the product of π and the square of the radius r .
In symbols,

$$A = \pi \cdot r^2$$

Note: $\pi \approx 3.14$ or $\frac{22}{7}$.

EXAMPLE 6 Area of a circle

Find the area of a circle with a radius of 3 centimeters. Use 3.14 for π .

SOLUTION 6

$$\begin{aligned} A &= (3.14) \cdot (3 \text{ cm})^2 = 3.14 \cdot (3 \text{ cm}) \cdot (3 \text{ cm}) \\ &= (3.14) \cdot (9 \text{ cm}^2) = 28.26 \text{ cm}^2 \end{aligned}$$

PROBLEM 6

Find the area of a circle with a radius of 2 inches. Use 3.14 for π .

EXAMPLE 7 Area of a circle

The Fermi National Accelerator Lab has the atom smasher shown in the photo. The smasher has a radius of 0.60 miles. What area does it cover? Use 3.14 for π .



SOLUTION 7 The area A of a circle is $A = \pi r^2$, where $r = 0.60$. Thus, the area is $A = \pi(0.60 \text{ mi})^2 \approx 3.14(0.36 \text{ mi}^2) = 1.1304 \text{ mi}^2$. That is, the accelerator covers about 1.1304 square miles.

PROBLEM 7

The photo shows several of the mysterious wheat circles appearing in Rockville, California. The biggest circle is claimed to be 140 feet in diameter. What is the area of this circle? Use 3.14 for π .

**GREEN MATH****EXAMPLE 8** Roof garden area and benefits

The idea of having a garden or a lawn on top of a home or building may seem a little bit odd but they do exist! The photo shows an architect's home in Chicago with its rooftop lawn. What is the area of the rooftop lawn (not including the elevated portion)?

PROBLEM 8

Find the area of the elevated smaller lawn, which measures 14 ft by 26 ft.

Answers to PROBLEMS

6. 12.56 in.² 7. 15,386 ft²

8. 364 square feet



SOLUTION 8 The area of the larger lawn can be divided into three rectangles measuring 20 ft by 36 ft, 26 ft by 12 ft, and another 20 ft by 36 ft. To find the total area, we find the area of the individual rectangles and add them. Since the area of a rectangle is the product of its length L and its width W , we have:

$$\text{The area of the 20 ft by 36 ft rectangle is } (20 \text{ ft}) \cdot (36 \text{ ft}) = 720 \text{ ft}^2$$

$$\text{The area of the 26 ft by 12 ft rectangle is } (26 \text{ ft}) \cdot (12 \text{ ft}) = 312 \text{ ft}^2$$

$$\text{The area of the 20 ft by 36 ft rectangle is } (20 \text{ ft}) \cdot (36 \text{ ft}) = 720 \text{ ft}^2$$

Thus, the total area of the rooftop lawn is 1752 square feet.

Some of the benefits of a roof-top garden are

1. Privacy.
2. Natural noise and thermal heat insulation, which cuts down on utility bills.
3. More room in your backyard for other projects.

Can you think of other benefits?

Calculator Corner

The squaring key x^2 is especially useful when working with area problems. For example, to find the area of a circle with a radius of 3 centimeters, you need to find $(3.14) \times (3)^2$, as in Example 6. This can be done by pressing **3** **.** **1** **4** **x** **3** **x²** **ENTER**. The correct result, 28.26, will be displayed.

In other mathematics courses, a more precise approximation for π might be necessary. If your calculator has a π key, this approximation is built into the calculator. Thus pressing the π key may give 3.1415927 as an approximation.

> Exercises 8.3



> Practice Problems > Self-Tests
> Media-rich eBooks > e-Professors > Videos

< A > Areas of Rectangles and Squares In Problems 1–9, find the area of the rectangle or square.

1. A rectangle 10 feet by 15 feet
2. A rectangle 5 inches by 3 inches
3. A rectangle 2 inches by 3 inches
4. A rectangle 3 yards by 2 yards
5. A rectangle 8 centimeters by 9 centimeters
6. A square 5 centimeters on each side

7. A square 9 inches on each side

8. A square 15 meters on each side

9. A square 9 yards on each side

< B > Area of a Triangle In Problems 10–20, find the area of the triangle.

10. A triangle whose base is 6 inches and whose height is 10 inches

11. A triangle of base 8 centimeters and height 7 centimeters

12. A triangle 20 millimeters high and with a 10-millimeter base

13. A triangle with a 50-millimeter base and a 7-millimeter height

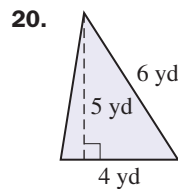
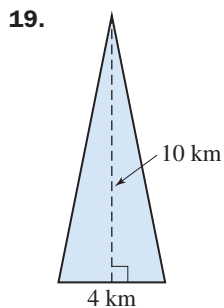
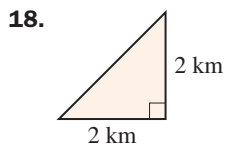
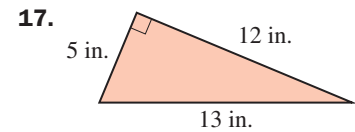
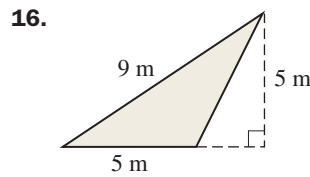
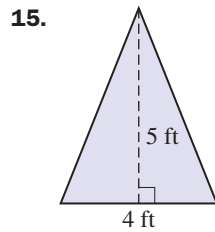
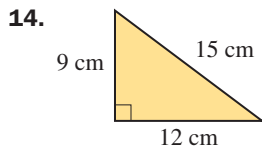

< C > Area of a Parallelogram In Problems 21–28, find the area of the parallelogram.

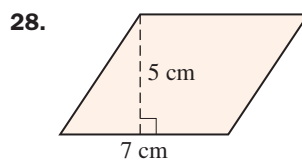
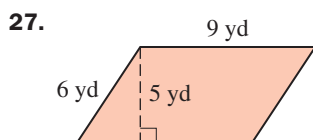
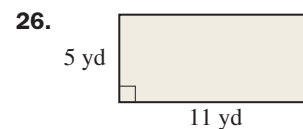
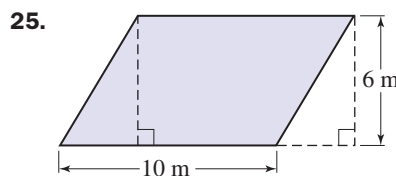
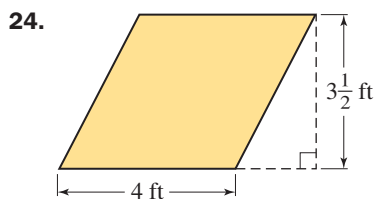
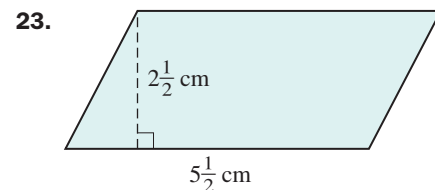
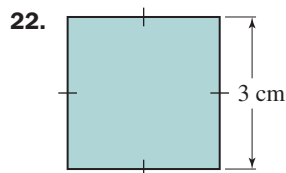
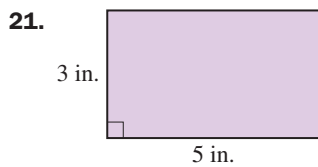

< D > Area of a Trapezoid In Problems 29–33, find the area of the trapezoid.

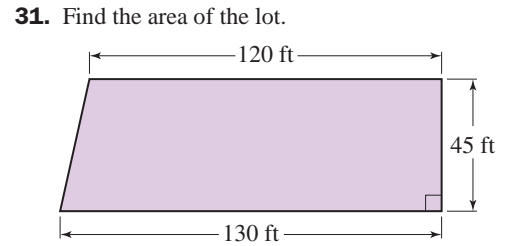
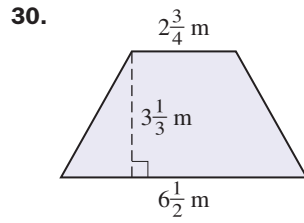
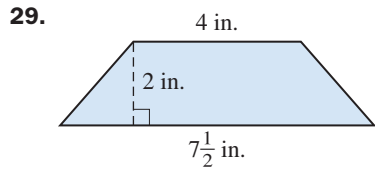

32. What is the area of the missile wing in square inches?

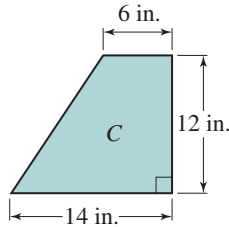

33. What is the area of the yard shown?

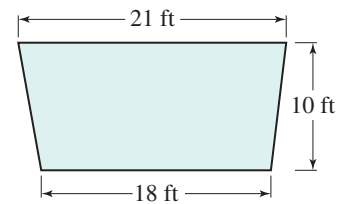

< E > Area of a Circle In Problems 34–40, find the area of the circle. Use 3.14 for π .

34. A circle with a 5-inch radius

35. A circle with a 4-inch radius

36. A circle with a 2-foot radius

37. A circle with a 7-centimeter radius

38. A circle with a 10-millimeter radius

39. A circle with a 1-meter radius

40. A circle with a 3-yard radius

In Problems 41–50, find the area of the shaded region by adding or subtracting the individual regions.

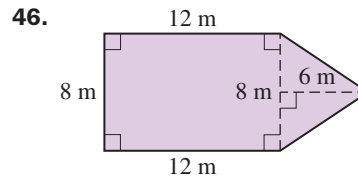
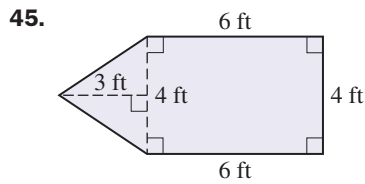
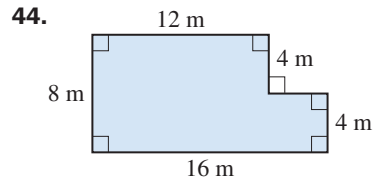
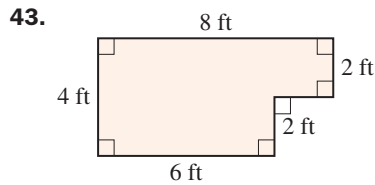
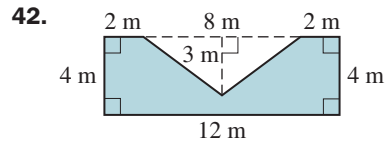
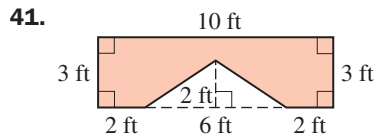

47. Use
- $\pi \approx 3.14$
- .

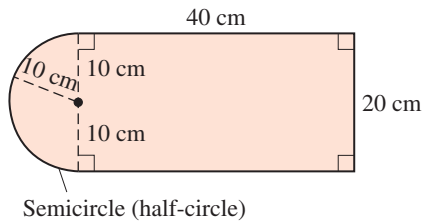

49. Use
- $\pi \approx 3.14$
- .

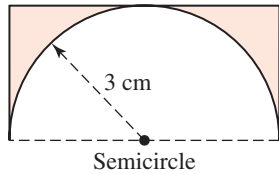

48. Use
- $\pi \approx 3.14$
- .

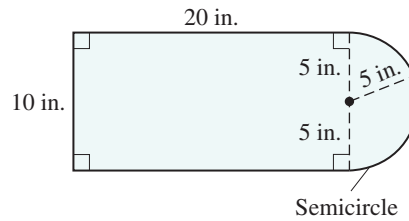

50. Use
- $\pi \approx 3.14$
- .

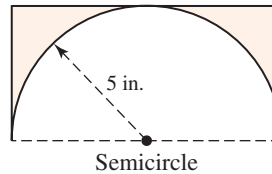

>>> Applications

- 51. Area of a baseball diamond** A baseball diamond is a square 90 feet on a side. What is its area?
- 52. Area of football field** A football field is 120 yards long and 160 feet wide. What is its area in square yards?
- 53. Area of a pizza** One of the largest pizzas ever made (in Glens Falls, N.Y.) had a 40-foot radius. What area was covered by this pizza? (Use 3.14 for π .)
- 54. Area of an omelet** One of the largest omelets made was cooked at Conestoga College, in Ontario, Canada. It measured 30 feet by 10 feet. What was the area of this rectangular omelet?
- 55. Area of a crater** The largest proven circular crater, which is in northern Arizona, is about 5200 feet wide. What is the area of this crater? (Use 3.14 for π .)
- In Problems 56–65, use 3.14 for π and give your answer to two decimal places.
- 56. Area of dinner plate** Find the area of a 6-inch dinner plate.
- 57. Area of Dutch crop circle** The diameter of the largest reported Dutch crop circle is 12 meters. What is its area?
- 58. Area of largest crop circle** The largest recorded crop circle appeared in Wiltshire, England, and is 240 meters in diameter. What is the area of the circle?
- 59. Area of bicycle wheel** The diameter of a bicycle wheel is 20 inches. What is the area of the wheel?
- 60. Area of a pizza** A pizza has an 18-inch diameter. What is the area of this pizza?
- 61. Mowed lawn area** A self-propelled lawnmower is tied to a pole in the backyard with a 20-foot rope. If the mower goes around in decreasing circles (because the rope is getting tied around the pole), what is the area the mower can mow?
- 62. Storm area** A summer storm is circular in shape with a 50-mile-long diameter. What area does this storm cover?
- 63. Area of sectors in wheel of fortune** A wheel of fortune has six sectors, half of which are red and half of which are yellow. If the radius of the wheel is 3 feet, what area is covered by the red sectors?
- 64. Sprinkled lawn area** A lawn sprinkler sprays water 10 feet away in every direction as it rotates. What area of the lawn is being sprinkled?
- 65. Area of Disneyland Carousel** The magical Carousel in Disneyland Paris has a radius of about 27 feet. What area does it cover?
- 66. Soccer** A regulation soccer field is a rectangle 60 yards wide and 100 yards long. What is the area of the field?
- 67. Soccer** The penalty box in a regulation soccer field is a rectangle 44 yards wide and 18 yards long. What is the area of the penalty box?

>>> Applications: Green Math

Area of Central Park in New York.

68. Central Park in New York is a rectangle 2.6 miles long and 0.5 miles wide. How many square miles is that?
69. When measuring in the metric systems, the park is 4.1 km long and 0.83 km wide. How many square kilometers is that?
70. A square mile is 640 acres. How many acres does Central Park cover? (*Hint*: See Exercise 68.)

>>> Using Your Knowledge

Areas of Irregular Figures You can use your knowledge of the formulas studied to find the areas of more complicated figures. For example, the area of the following sheet metal blank can be found by adding the area of the rectangle to the area of the two half-circles (which add up to the area of a circle).

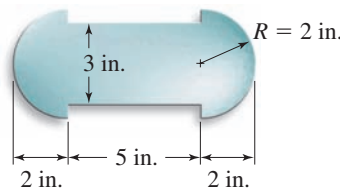

71. Find the area of the rectangle.
72. Find the area of each half-circle. Use 3.14 for π .
73. Find the total area.

Sometimes we *subtract* to find areas. The area of the following plate is the area of the trapezoid *minus* the area of the rectangle.

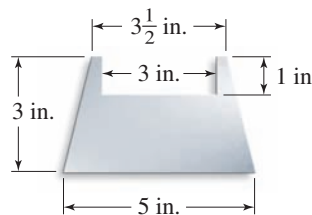

74. Find the area of the trapezoid.
75. Find the area of the rectangle.
76. Find the total area of the plate.

>>> Write On

77. A small pizza 11 inches in diameter costs \$8 and a large pizza 15 inches in diameter costs \$15. Which is the better deal, to buy two small pizzas or one large one? *Hint*: Find out how many square inches you get per dollar.
78. Which do you think is a better illustration of a circle: a perfectly round penny or a bicycle tire? Explain.

>>> Concept Checker

Fill in the blank(s) with the correct word(s), phrase, or mathematical statement.

79. The **area** of a **rectangle** of length L and width W is _____.

$$\pi r^2$$

$$\pi r$$

80. The **area** of a _____ of base b and height h is _____.

triangle

$$2\pi r$$

81. The **area** of a **parallelogram** of base b and height h is _____.

$$\frac{1}{2}bh$$

$$bh$$

82. The **area** of a **circle** of radius r is _____.

$$L + W$$

$$LW$$

>>> Mastery Test

83. A wheat circle is 120 feet in diameter. What is the area of this circle? (Use 3.14 for π .)
84. Find the area of a circle with a radius of 10 centimeters. (Use 3.14 for π .)
85. Find the area of the trapezoid.
86. Find the area of the parallelogram.

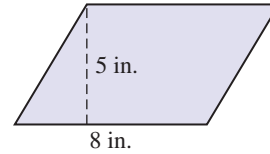
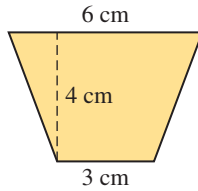

87. Find the area of a triangular piece of cloth 20 centimeters long and 10 centimeters high.
88. Find the area of a square whose side is 10 inches long.
89. Find the area of a rectangle 8 meters by 3 meters.

>>> Skill Checker

In Problems 90–94, perform the indicated operations.

90. $3 \cdot 2 \cdot \frac{1}{3}$

91. $\frac{10}{3} \cdot 2 \cdot \frac{1}{2}$

92. $(2)(18)(0.333)$

93. $(0.5)(22)(20)$

94. $(0.62)(0.62)(0.62)$ (Answer to two decimal places.)

8.4

Volume of Solids

▶ Objectives

You should be able to:

- A > Find the volume of a rectangular solid.
- B > Find the volume of a cylinder.
- C > Find the volume of a sphere.
- D > Find the volume of a circular cone.
- E > Find the volume of a pyramid.
- F > Solve applications involving the volume of solids.

▶ To Succeed, Review How To . . .

1. Perform the four fundamental operations using fractions. (pp. 136–140, 157–163)
2. Evaluate an expression containing exponents. (pp. 78, 83–85)

▶ Getting Started

Which bread has more volume, the Cuban bread (cylindrical) or the Greek bread (doughnut shaped)? To answer the question, you need to know the formula for finding the volume of a **cylinder**. Before we do that, let us learn how to calculate the volume of a simpler **rectangular solid** shaped like a box.



A > Volume of Rectangular Solids

The volume of a rectangular solid is the number of unit cubes it takes to fill it. In the metric system a solid cube 1 centimeter on each side is defined to be the *unit* of volume, $1 \text{ cm} \times 1 \text{ cm} \times 1 \text{ cm} = 1 \text{ cm}^3$ (read “one cubic centimeter”). Other units of volume are the cubic meter and, in the customary system, the cubic foot and cubic yard. (Note that volume is measured in *cubic* units.)

As in the case of areas, the volume of a rectangular solid object equals the number of units of volume it contains. Suppose you have a block 3 centimeters long, 2 centimeters wide, and 2 centimeters high. You can see that the top layer has 3 rows each containing 2 unit volumes, that is, 6 cubic centimeters (cm^3) in all. Since the bottom layer is identical, the volume of this cube is 12 cubic centimeters. This volume can also be found by multiplying $2 \text{ cm} \times 3 \text{ cm} \times 2 \text{ cm} = 12 \text{ cm}^3$. In general, the volume V of a rectangular solid is found by multiplying the length L times the width W times the height H . This is also the area of the base ($L \cdot W$) times the height (H) of the solid.

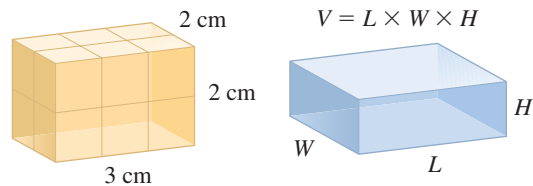

VOLUME OF A RECTANGULAR SOLID

The volume V of a rectangular solid is the product of its length L , its width W , and its height H . In symbols,

$$V = \underbrace{L \cdot W}_{\text{Base area}} \cdot H$$

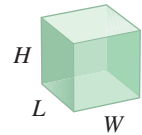

EXAMPLE 1 Volume of a rectangular solid

Find the volume of this solid.

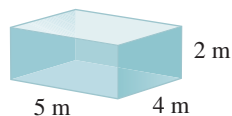

SOLUTION 1 The volume is $5 \text{ m} \cdot 4 \text{ m} \cdot 2 \text{ m} = 40 \text{ m}^3$.

PROBLEM 1

Find the volume of this solid.

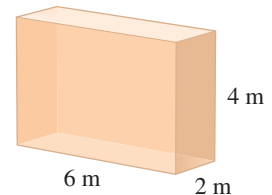

In some instances, we need to do some conversions within a system to obtain the desired units in the answer. For example, concrete is sold by the cubic yard (yd^3). Thus, to estimate how much concrete is needed to fill a wooden box form 9 feet long, 6 feet wide, and 12 inches thick, we first have to write all the measurements in yards. Thus,

$$\begin{aligned} 9 \text{ ft} &= 3 \text{ yd} \\ 6 \text{ ft} &= 2 \text{ yd} \\ 12 \text{ in.} &= \frac{1}{3} \text{ yd} \end{aligned}$$

The volume of the box is

$$V = L \cdot W \cdot H = 3 \text{ yd} \cdot 2 \text{ yd} \cdot \frac{1}{3} \text{ yd} = 2 \text{ yd}^3$$

Answers to PROBLEMS

1. 48 m^3

EXAMPLE 2 Volume of a rectangular space

How many cubic yards of concrete are needed to fill a hole 10 feet long, 6 feet wide, and 18 inches thick?

SOLUTION 2 Recall that 3 ft = 1 yd and 1 ft = 12 inches.

$$10 \text{ ft} = 3\frac{1}{3} \text{ yd}, \quad 6 \text{ ft} = 2 \text{ yd}, \quad \text{and} \quad 18 \text{ in.} = \frac{1}{2} \text{ yd}$$

Thus, the volume is

$$\begin{aligned} V &= L \cdot W \cdot H = 3\frac{1}{3} \text{ yd} \cdot 2 \text{ yd} \cdot \frac{1}{2} \text{ yd} \\ &= 3\frac{1}{3} \text{ yd}^3 \end{aligned}$$

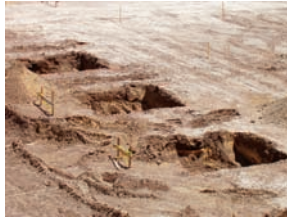
**PROBLEM 2**

How many cubic yards of concrete are needed to fill a hole 18 feet long, 4 feet wide, and 9 inches thick?

B > Volume of Cylinders

Most soda cans are made of aluminum and are in the shape of a cylinder about 5 inches in height and 2 inches in diameter. How do we find the volume of such a can? The volume of a circular cylinder like the can is found in the same way as the volume of a rectangular solid: it is the product of the area of the base times the height. For a circular cylinder of radius r and height h , the area of the base will be the area of a circle, that is, πr^2 . In order to find the volume we multiply the base area (πr^2) by the height h .

VOLUME OF A CIRCULAR CYLINDER

The volume V of a circular cylinder of radius r and height h is the product of π , the square of the radius r , and its height h . In symbols,

$$V = \pi \cdot r^2 \cdot h$$

Base
area

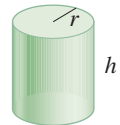
**EXAMPLE 3** Volume of a cylinder

Find the volume of the can. Use 3.14 for π .

SOLUTION 3 The can is in the shape of a circular cylinder, and its volume is

$$\begin{aligned} V &= \pi \cdot r^2 \cdot h \\ &= 3.14 \cdot (1 \text{ in.})^2 \cdot (5 \text{ in.}) \\ &= 15.7 \text{ in.}^3 \end{aligned}$$

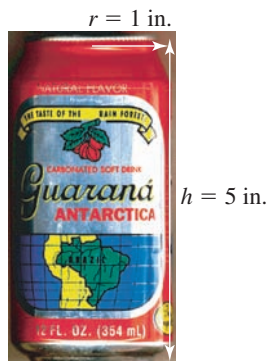
**PROBLEM 3**

Find the volume of a can 6 inches high with a radius of 1 inch. Use 3.14 for π .

Answers to PROBLEMS

2. 2 yd³ 3. 18.84 in.³

C > Volume of Spheres



The two bowling balls are shaped like **spheres**. A sphere is a three-dimensional solid that is defined as the set of all points in space that are a given distance (the radius r) from its center. The volume of a sphere of radius r is given by the following formula.

VOLUME OF A SPHERE

The volume V of a sphere of radius r is the product of $\frac{4}{3}\pi$ and the radius cubed. In symbols,

$$V = \frac{4}{3}\pi \cdot r^3$$

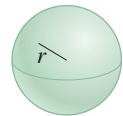

EXAMPLE 4 Volume of bowling ball

The radius of a bowling ball is 10.9 centimeters. Find the volume of the ball. Use 3.14 for π and round the answer to the nearest hundredth of a cubic centimeter.

SOLUTION 4 The volume of a sphere is $V = \frac{4}{3} \cdot \pi \cdot r^3$

$$\begin{aligned} &= \frac{4}{3} \cdot 3.14 \cdot (10.9 \text{ cm})^3 \\ &= \frac{4 \cdot 3.14 \cdot 1295.029}{3} \text{ cm}^3 \\ &\approx 5421.85 \text{ cm}^3 \end{aligned}$$

PROBLEM 4

Find the volume of a bowling ball that is about 4.3 inches in diameter. Use 3.14 for π and round the answer to the nearest hundredth of a cubic inch.



D > Volume of Circular Cones

Do you know the name of the geometric shape of the hat the boy is wearing? In geometry, it is called a circular cone, but you probably know it as a “dunce cap,” a term originating from the name of the 18th century scholastic theologian, John Duns Scotus. The volume of a circular cone of radius r and height h is given by the formula in the box below.

VOLUME OF A CIRCULAR CONE

The volume V of a cone of radius r is $\frac{1}{3}\pi$ times the product of the radius squared and the height h . In symbols,

$$V = \frac{1}{3}\pi \cdot \underbrace{r^2}_{\text{Base area}} \cdot h$$

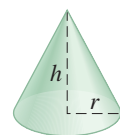

Answers to PROBLEMS

4. 41.61 in.³

EXAMPLE 5 Volume of a cone hat

If the cone on the boy's head is 10 centimeters high and has a radius of 5 centimeters, what is its volume? Use 3.14 for π and round the answer to the nearest hundredth of a cubic centimeter.

SOLUTION 5 The volume of a circular cone is $V = \frac{1}{3}\pi \cdot r^2 \cdot h$

$$= \frac{1}{3} \cdot 3.14 \cdot (5 \text{ cm})^2 \cdot (10 \text{ cm})$$

$$\approx 261.67 \text{ cm}^3$$

PROBLEM 5

Find the volume of the pink princess party and dressup hat, which is 14 inches tall and has a diameter of 4 inches. Use 3.14 for π and round the answer to the nearest hundredth of a cubic inch.

**E > Volume of Pyramids**

Do you recognize the shape of the structure in the photo? It is a **pyramid** (from the Greek word *pyra* meaning fire, light, or visible, and the word *midos* meaning measures, even though other scholars claim that the origin of the word is the Greek word *pyramis*, meaning wheat cake!). The pyramid in the photo is the Great Pyramid at Giza built by King Khufus, also known as Cheops, from 2589 to 2566 B.C. What is the volume of this pyramid?

**VOLUME OF A PYRAMID**

The volume V of a pyramid is the product of $\frac{1}{3}$ of its base area B and its height h . In symbols,

$$V = \frac{1}{3} \underbrace{B}_{\substack{\text{Base} \\ \text{area}}} \cdot h$$

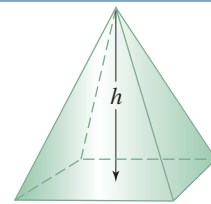
**EXAMPLE 6** Volume of the original Great Pyramid

The base of the Great Pyramid is a square with each side measuring 230 meters. If the height of the pyramid is 147 meters, what is its volume?

SOLUTION 6 The volume of a pyramid is $V = \frac{1}{3}Bh$. The area of the square base B is $230 \text{ m} \cdot 230 \text{ m} = 52,900 \text{ m}^2$ and the height h is 147 meters. Substituting for B and h ,

PROBLEM 6

Did you know that the Great Pyramid has shrunk? Actually, due to the loss of its outer casing stones, the base is now 227 meters and its height is 137 meters (having lost 10 meters in height). To the nearest cubic meter, what is the volume of the pyramid now?

Answers to PROBLEMS

5. 58.61 in.³ 6. 2,353,158 m³

$$\begin{aligned}
 V &= \frac{1}{3}Bh \\
 &= \frac{1}{3}(52,900 \text{ m}^2)(147 \text{ m}) \\
 &= (52,900 \text{ m}^2) \left(\frac{147 \text{ m}}{3} \right) \\
 &= (52,900 \text{ m}^2)(49 \text{ m}) \\
 &= 2,592,100 \text{ m}^3
 \end{aligned}$$

Thus, the volume of the original pyramid is 2,592,100 cubic meters. But the pyramid has shrunk; see Problem 6 to discover by how much!

Source: <http://www.pbs.org>.

F > Applications Involving Volume

So many applications and so little space! The formulas for the volume of the solids we have discussed can be used to find the volume of a Pet Taxi (carrier for animals), the amount of soil to be removed from a contaminated landfill, the amount of medication in a cylindrical pill, a microwave or toaster oven's capacity, the volume of boxes or trucks used for moving, and many other applications. Here are some samples.

GREEN MATH

EXAMPLE 7 Volume of contaminated soil removed

How much soil was removed from the portion of the hole shown? Give the answer in cubic yards.



Here, personnel use heavy equipment to remove contaminated soils from a site. EPA conducts removal actions at long-term Superfund sites to address immediate threats to human health or the environment.

SOLUTION 7 Since the answer has to be in cubic yards, we assume that the hole is a rectangular box 20 yards long, 2 yards wide, and 1 yard deep.

(Note: 6 ft = 2 yd and 3 ft = 1 yd.)

$$\begin{aligned}
 \text{The volume of a rectangular solid is } V &= L \cdot W \cdot H \\
 &= (20 \text{ yd}) \cdot (2 \text{ yd}) \cdot (1 \text{ yd}) \\
 &= 40 \text{ yd}^3
 \end{aligned}$$

This is the capacity of two large dump trucks!

PROBLEM 7

A much larger trench has been dug in the background. If the dimensions of that trench are 120 feet long by 6 feet wide by 3 feet deep, how many cubic yards of soil were removed from that trench?

Answers to PROBLEMS

7. 80 yd³

EXAMPLE 8 Volume of a capsule

The capsules are in the shape of a cylinder 12 millimeters long with two half spheres with a diameter of 2 millimeters at each end. What is the volume of the capsule? Use 3.14 for π and round the answer to the nearest hundredth of a cubic millimeter.

SOLUTION 8 We have to find the volume V of the cylinder plus the volume of the two half spheres (which make up one whole sphere).

The volume of the cylinder is $V = \pi \cdot r^2 \cdot h$
 Here,
 $r = 1$ mm and $h = 12$ mm, so $V = 3.14 \cdot (1 \text{ mm})^2 \cdot (12 \text{ mm})$
 $= 37.68 \text{ mm}^3$

The volume of the sphere is $V = \frac{4}{3} \cdot \pi \cdot r^3$
 $= \frac{4}{3} \cdot 3.14 \cdot (1 \text{ mm})^3$
 $= \frac{4 \cdot 3.14 \cdot 1}{3} \text{ mm}^3$
 $\approx 4.19 \text{ mm}^3$

The volume of the whole capsule is $37.68 + 4.19 = 41.87 \text{ mm}^3$.

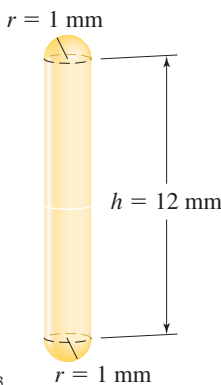
**PROBLEM 8**

Suppose the capsules are in the shape of a cylinder 10 millimeters long with two half spheres of diameter 2 millimeters at each end. What is the volume of each capsule? Use 3.14 for π and round the answer to the nearest hundredth of a cubic millimeter.

Answers to PROBLEMS
 8. 35.59 mm³

> Exercises 8.4

> Practice Problems > Self-Tests
 > Media-rich eBooks > e-Professors > Videos

<A> Volume of Rectangular Solids In Problems 1–4, find the volume of the rectangular solid with the indicated dimensions.

	Length	Width	Height
1.	8 cm	5 cm	6 cm
2.	15 cm	20 cm	9 cm

	Length	Width	Height
3.	$9\frac{1}{2}$ in.	3 in.	$4\frac{1}{2}$ in.
4.	$5\frac{1}{4}$ in.	$1\frac{3}{8}$ in.	$\frac{5}{8}$ in.

5. The Pet Kennel measures 26 inches long, 19 inches high, and 16 inches wide. What is the volume of the Pet Kennel?



6. The Pet Taxi is 16 inches long, 10 inches high, and 11 inches wide. What is the volume of the Pet Taxi?



7. The inside dimensions of the toaster are 11 inches wide, 8 inches deep, and 5 inches high. What is the volume of the inside of the toaster?



8. The inside dimensions of the microwave are 16 inches by 11 inches by 13 inches. What is the volume of the inside of the microwave?



9. A swimming pool measuring 30 feet by 18 feet by 6 feet is to be excavated. How many cubic yards of dirt must be removed? (*Hint*: Change the feet to yards first.)
11. A rectangular tank measures 30 feet by 3 feet by 2 feet. How many gallons of water will it hold if $1 \text{ ft}^3 = 7.5$ gallons?
13. Where do you use the most water at home? In the toilet! If the toilet tank is 18 inches long, 8 inches wide, and the water is 12 inches deep, how many gallons of water does the toilet tank contain? ($1 \text{ ft}^3 = 7.5$ gal; answer to the nearest gallon.)
10. How many cubic yards of sand are being transported in a dump truck whose loading area measures 9 feet by 4 feet by 3 feet?
12. A hot tub measures 4 feet by 6 feet and is 3 feet deep. How many gallons of water will it hold if $1 \text{ ft}^3 = 7.5$ gallons?
14. How much concrete is needed to build a roadway 45 feet wide, 1 foot thick, and 10 miles long (1 mile = 5280 ft)?

< B > Volume of Cylinders In Problems 15–20, find the volume of a cylinder with the given radius and height. (Use 3.14 for π and round the answer to the nearest tenth.)

	Radius	Height
15.	10 in.	8 in.
16.	4 in.	18 in.

	Radius	Height
17.	10 cm	20 cm
18.	3.5 cm	2.5 cm

	Radius	Height
19.	1.5 m	4.5 m
20.	0.8 m	3.2 m

21. Find the volume of the large 4-foot-high, 1-foot-diameter cylinder. Use 3.14 for π and round the answer to the nearest hundredth.



22. Find the volume of the small 2-foot-high, 1-foot-diameter cylinder. Use 3.14 for π and round the answer to the nearest hundredth.

23. Each sugar container is 5 inches high and 3 inches in diameter. Find the volume of one container. Use 3.14 for π and round the answer to the nearest hundredth.



24. What is the volume of the sugar in the three containers? Note that one of the containers is half-full. Use 3.14 for π and round your answer to the nearest whole number.

In Problems 25–28, use 3.14 for π , and round the answer to the nearest tenth.

25. A cylindrical tank has a 20-foot diameter and is 40 feet high. What is its volume?
27. A coffee cup has a 3-inch diameter and is 4 inches high. What is its volume? If $1 \text{ in.}^3 = 0.6 \text{ fl oz}$, how many fluid ounces does the cup hold?
26. A steel rod is $\frac{1}{2}$ inch in diameter and 18 feet long. What is its volume?
28. A coffee cup is 3 inches in diameter and 3.5 inches high. Find the volume and determine if a 12-fluid-ounce soft drink will fit in the cup ($1 \text{ in.}^3 = 0.6 \text{ fl oz}$).

< C > Volume of Spheres In Problems 29–32, use 3.14 for π and round the answer to the nearest tenth.

29. A spherical water tank has a 24-foot radius. How many gallons of water will it hold if 1 cubic foot holds about 7.5 gallons?
31. The fuel tanks on some ships are spheres, of which only the top halves are above deck. If one of these tanks is 120 feet in diameter, how many gallons of fuel does it hold ($1 \text{ ft}^3 = 7.5$ gal)?
30. A spherical water tank has a 7.2-meter radius. How many liters of water will it hold if 1 cubic meter holds 1000 liters?
32. The Christmas ornament has a 2-inch diameter. What is its volume?



- < D > Volume of Circular Cones** In Problems 33–37, find the volume of a circular cone with the given radius and height. Use 3.14 for π and round the answer to the nearest tenth.

	Radius	Height
33.	10 in.	6 in.
34.	18 in.	12 in.
35.	50 ft	20 ft

38. *Volume of funnel* The inside of the funnel is 8 centimeters in diameter and 7 centimeters high. What is the volume of the funnel? Use 3.14 for π and round the answer to the nearest tenth.



	Radius	Height
36.	10 ft	50 ft
37.	0.6 m	1.2 m

39. *Volume of smaller funnel* The inside of the funnel is 7 centimeters in diameter and 6 centimeters high. What is the volume of the funnel? Use 3.14 for π and round the answer to the nearest tenth.



< E > Volume of Pyramids

40. *Volume of a pyramid* Most people associate pyramids with Egypt (see Example 6), but did you know that there are ancient pyramids in Teotihuacan, Mexico? The Pyramid of the Sun has a height of 233.5 feet (about half that of the Great Pyramid) but its square base is 733 feet on each side (the Great Pyramid is 756 feet on each side). What is the volume of the Pyramid of the Sun? Answer to the nearest cubic foot.



The Great Pyramid superimposed over the Pyramid of the Sun.

41. *Volume of a pyramid* The second photo shows the Pyramid of the Moon also built at Teotihuacan, Mexico, between A.D. 150 and 225. Its base measures 492 feet on each side and its height is 138 feet. What is the volume of the Pyramid of the Moon?



Pyramid of the Moon

< F > Applications Involving Volume

42. *Volume of boxes* Have you moved to the dorm or an apartment lately? You probably needed some boxes with some of the dimensions shown. Give the answer in both cubic inches and cubic feet. (1 cubic foot = 1728 cubic inches)
- Find the volume of the small box.
 - Find the volume of the medium box.
 - Find the volume of the large box.
 - Which of the three volumes shown for the boxes (1.5 cu ft, 3.0 cu ft, 4.5 cu ft, and 6.0 cu ft) agrees exactly with your answer, the box in **a**, **b**, or **c**?

• Small Box	$16'' \times 12'' \times 12''$	1.5 cu/ft
• Medium Box	$18'' \times 18'' \times 16''$	3.0 cu/ft
• Large Box	$18'' \times 18'' \times 24''$	4.5 cu/ft
• Extra-Large Box	$24'' \times 18'' \times 24''$	6.0 cu/ft

43. *Volume of a truck* You probably needed a truck to move. The U-Haul truck has the dimensions shown.

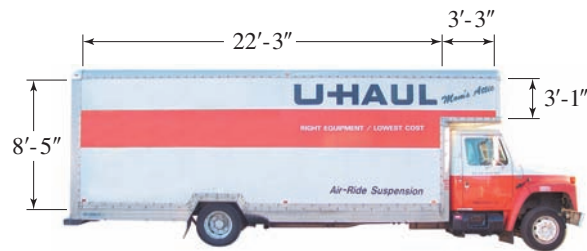

Inside dimensions: $22'-3'' \times 7'-7'' \times 8'-5''$ ($L \times W \times H$)

Dimensions over the truck cab: $3'-3'' \times 7'-7'' \times 3'-1''$ ($L \times W \times H$)

44. *U-Haul recommendations* If you have a two- to three-room apartment, U-Haul recommends a 1200- to 1600-cubic foot truck.

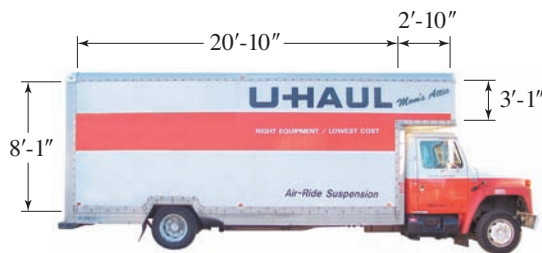

Inside dimensions: $20'-10'' \times 7'-6'' \times 8'-1''$ ($L \times W \times H$)

Dimensions over the truck cab: $2'-10'' \times 7'-6'' \times 3'-1''$ ($L \times W \times H$)

- Approximate the inside dimensions of the truck to 20 feet by 7 feet by 8 feet. What is the volume?
- Approximate the dimensions over the truck cab to 3 feet by 7 feet by 3 feet. What is the volume?
- If you have a two-room apartment, U-Haul recommends a truck with a minimum of 1200 cubic feet of space. Does this truck meet that recommendation?

47. *UPS box volume* The UPS box is approximately 36 inches high by 24 inches wide by 20 inches deep. Give the answer in both cubic inches and cubic feet. ($1 \text{ ft}^3 = 1728 \text{ in.}^3$)

- What is the volume of the box?
- You cannot fill the box to the top. The actual effective area where you can place your mail is only 24 inches high. What is the volume of the effective area for the box?



49. *Volume of a funnel cloud* Assume a funnel cloud has a 300-foot diameter and it is 600 feet high. What is the volume of the funnel cloud? Use 3.14 for π .

- Approximate the inside dimensions of the truck to 22 feet by 7 feet by 8 feet. What is the volume?
- Approximate the dimensions over the truck cab to 3 feet by 7 feet by 3 feet. What is the volume?
- You estimate that you have 1300 cubic feet of stuff to be moved. Does your stuff theoretically fit in the truck? Explain. (*Hint:* Don't forget the space in over the truck cab.)

45. *Bench volume* Some benches at the University of South Florida are in the form of a hemisphere (half of a sphere) with a 34-inch diameter. Use 3.14 for π and give the answer (to the nearest tenth) in both cubic inches and cubic feet. ($1 \text{ ft}^3 = 1728 \text{ in.}^3$)



- If the bench were a sphere (instead of a hemisphere), what would be its volume?
- Since the bench is a hemisphere, its volume is $\frac{1}{2}$ the volume of a sphere. What is this volume?

46. *Pendulum volume* The pendulum at USF has a diameter of 2 feet. If we assume that the pendulum is a sphere, how much metal was used to make it? Use 3.14 for π and give the answer to the nearest tenth.

48. *Volume of a funnel cloud* Funnel clouds can be 300 to 2000 feet in diameter. Assume the funnel cloud in the photo is 1000 feet in diameter and 2000 feet high. What is the volume of this funnel cloud? Use 3.14 for π and give the answer to the nearest tenth.



Applications: Green Math

In Section 8.1, Example 10, we mentioned a study regarding the ability of students to find recycling bins on campus. How do the recycling bins on your campus look like? What is their volume? How many truckloads of garbage do they fill? You can answer some of those questions by working Problems 50–55!

Volume of garbage cans What is the volume (capacity) of the garbage cans they use at your school? The volume of the can consists of two parts: the cylindrical bottom (2.5 feet high, 1.5 feet diameter) and the hemisphere (half of a sphere). (Use 3.14 for π and round the answer to the nearest tenth.)

50. What is the volume of the cylindrical part?
51. What is the volume of the hemispherical top?
52. What is the volume of the entire trash can?
53. The chemistry building has three floors and there are four trash cans on each floor. What is the volume of the trash cans on the three floors of the chemistry building?
54. **Trash Capacity** The USF garbage truck carries about 500 cubic feet of trash. How many cans of trash can it carry? (Use the volume you found for the trash can in Problem 52.)
55. **Trucks needed for the garbage** If we assume that every building has three floors and four trash cans on each floor, how many buildings can the truck service? (*Hint:* How many 12-can loads fit in the truck?)



Using Your Knowledge

Volume of Bread In the *Getting Started*, we raised the question: which bread has more volume? We now have the knowledge to answer. Use 3.14 for π and round the answer to the nearest tenth.

56. The Cuban bread loaf is almost a cylinder 20 inches long with a 3-inch diameter. What is the approximate volume of the Cuban loaf?
57. The Greek bread is almost shaped like a cylinder 8 inches in diameter and 2 inches high. What is the approximate volume of the cylinder?
58. The answer in Exercise 57 does not really give the volume of the Greek bread because the bread has a hole 3 inches in diameter in the middle. What is the volume of this hole? Actually, 0 because there is no bread there! Find the volume of the empty space in the middle of the bread and subtract it from the answer you got in Exercise 57; that is the volume of the Greek bread! Is it more or less than the volume of the Cuban bread of Exercise 56?
59. Here is another way to find the volume of the Greek bread. Suppose you make a vertical cut perpendicular to the ground on the bread and “stretch” the bread into a loaf. How long would that loaf be? Remember, the outside diameter is 8 inches.
60. Since the original Greek bread was 2 inches high, we can assume that the new loaf of Greek bread has a 2-inch diameter. Now, use your answer to Exercise 59 (that would give you the length of the new loaf) and find the volume of the Greek loaf. Is it approximately the same answer as the one you obtained in Exercise 58?

Write On

61. Burger King, McDonald’s, and other hamburger stores compare the amount of beef they have in their hamburgers. When doing so, should you compare the circumference, the area, or the volume of the hamburgers? Explain.
62. “In men’s play, a basketball is 29.5 to 30 inches (74.9 to 76.2 centimeters) in diameter.” What is wrong with that statement? Write in your own words how the statement should be stated.

Concept Checker

Fill in the blank(s) with the correct word(s), phrase, or mathematical statement.

63. The volume of a **rectangular solid** of length L , width W , and height H is _____.
64. The **volume** of a **cylinder** of radius r and height h is _____.

$$\frac{1}{3}\pi r^2 h$$

$$\pi r^3$$

$$LWH$$

$$\frac{1}{3}\pi r^3$$

65. The **volume** of a **sphere** of radius r is _____.

$$\pi r^2 h$$

$$\frac{4}{3}\pi r^3$$

66. The **volume** of a **cone** of radius r and height h is _____.

$$\pi r h$$

>>> **Mastery Test**

In Problems 67–71, use 3.14 for π when necessary and round the answer to the nearest tenth.

67. Find the volume of a circular cone 10 centimeters high and with a 6-centimeter radius.

68. How many cubic yards of sand are needed to fill a sandbox 9 feet long by 3 feet wide and 4 inches deep?

69. Find the volume of a bowling ball with a 4.2-inch diameter.

70. Find the volume of the solid.

71. Find the volume of a can 8 inches high with a 1-inch radius.

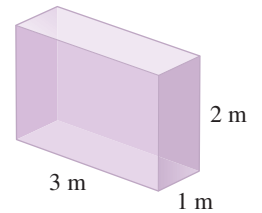

>>> **Skill Checker**

In Problems 72–73 evaluate:

72. $9^2 + 12^2$

73. $8^2 + 11^2$

8.5

Square Roots and the Pythagorean Theorem

▶ Objectives

You should be able to:

- A** > Find the exact and approximate square root of a number.
- B** > Use the Pythagorean theorem to find the length of one of the sides of a right triangle when the two other sides are given.
- C** > Solve applied problems using the Pythagorean theorem.

▶ To Succeed, Review How To . . .

1. Add, subtract, multiply, and divide whole numbers. (pp. 24, 38, 50, 65)
2. Solve equations. (pp. 91–92, 251–252)

▶ Getting Started

In the photo at the beginning of the chapter (shown here reduced), the length c of the upper arm of the player is $\sqrt{0.0884}$ meter (read “the square root of 0.0884”) and was obtained by using the Pythagorean theorem. What does “the square root of a number” mean? What is the Pythagorean theorem? We will discuss both topics next.

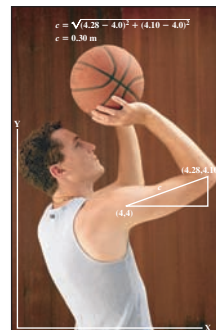

B > The Pythagorean Theorem

In the photo in the *Getting Started*, the length of the arm of the player is c , the longest side (the hypotenuse) of a right triangle whose sides (legs) measure 0.28 meter and 0.10 meter as shown:

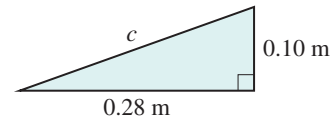

The relationship between the length of the legs a and b and the length of the hypotenuse c is given by $a^2 + b^2 = c^2$.

This fact, proved by the Greek mathematician Pythagoras over 2500 years ago, is true for all right triangles and is stated next.

THE PYTHAGOREAN THEOREM

In any right triangle with legs of length a and b and hypotenuse c ,

$$a^2 + b^2 = c^2$$

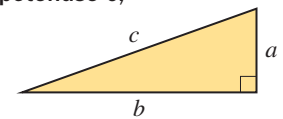

Thus, if we are given the lengths of any two sides of a right triangle, we can always find the length of the third side using the Pythagorean theorem. Note that the converse of the theorem is also true.

CONVERSE OF THE PYTHAGOREAN THEOREM

If $a^2 + b^2 = c^2$, then the triangle is a right triangle.

EXAMPLE 3 Finding the length of the hypotenuse

Find the length c of the hypotenuse of the given right triangle.

SOLUTION 3

Using the Pythagorean theorem, $a^2 + b^2 = c^2$
 Substituting $a = 3, b = 4$ $3^2 + 4^2 = c^2$
 Simplifying $9 + 16 = c^2$
 Adding $25 = c^2$
 Solving for c $c = \sqrt{25} = 5$

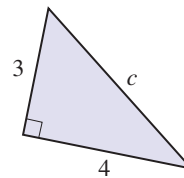

Thus, the length of the hypotenuse c is 5.

CHECK $3^2 + 4^2 = 5^2$

PROBLEM 3

Find the length c of the hypotenuse of the triangle.

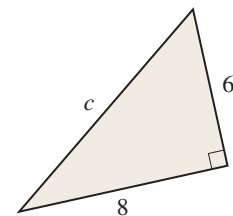

EXAMPLE 4 Finding the length of a leg

Find the length a for the given right triangle.

SOLUTION 4

Using the Pythagorean theorem, $a^2 + 5^2 = 6^2$
 with $b = 5$ and $c = 6$
 Simplifying $a^2 + 25 = 36$
 Subtracting 25 from both sides $a^2 = 11$
 Solving for a $a = \sqrt{11}$

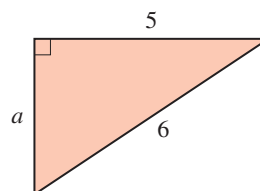

Thus, the exact length of a is $\sqrt{11}$.

The approximate length of a , using a calculator, is 3.317.

PROBLEM 4

Find the length a for the given triangle.

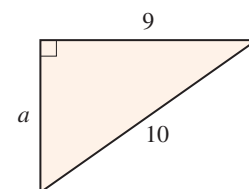

Answers to PROBLEMS

3. $c = 10$ 4. $a = \sqrt{19} \approx 4.359$



C > Applications of the Pythagorean Theorem

Television sets and computer monitors are classified according to the length of the diagonal (hypotenuse) of the set or screen. Thus, a 15-inch screen means that the diagonal of the set or monitor is 15 inches. For example, the screen of the laptop is about 12 inches wide by 9 inches high. Is it really a 15-inch monitor?

We shall see next.

EXAMPLE 5 Finding the length of the hypotenuse

Find the length of the diagonal of the screen with the given dimensions.

SOLUTION 5

$$\begin{array}{l} \text{Using the Pythagorean theorem, } a^2 + b^2 = c^2 \\ \text{Substituting } a = 9, b = 12 \quad 9^2 + 12^2 = c^2 \\ \text{Simplifying} \quad 81 + 144 = c^2 \\ \text{Adding} \quad 225 = c^2 \\ \text{Solving for } c \quad c = \sqrt{225} = 15 \end{array}$$

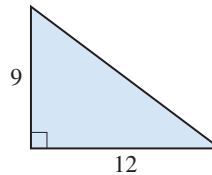

Thus, the hypotenuse is 15, and we do have a 15-inch screen.

PROBLEM 5

Find the length of the diagonal of a television screen 16 inches wide and 12 inches high.

EXAMPLE 6 Finding the length of the hypotenuse

A baseball diamond is really a square with sides of 90 feet. To the nearest whole number, how far is it from first base to third base?

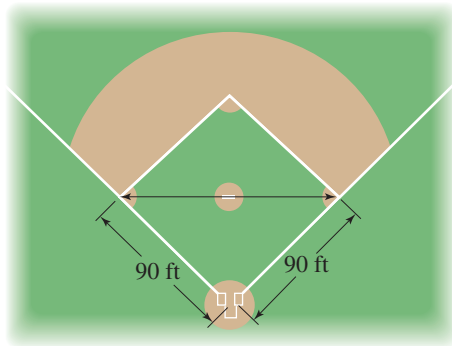

SOLUTION 6 In this case $a = b = 90$.

$$\begin{array}{l} \text{Using the Pythagorean theorem, } a^2 + b^2 = c^2 \\ \text{Substituting } a = 90, b = 90 \quad 90^2 + 90^2 = c^2 \\ \text{Simplifying} \quad 8100 + 8100 = c^2 \\ \text{Adding} \quad 16,200 = c^2 \\ \text{Solving for } c \quad c = \sqrt{16,200} \approx 127 \text{ ft} \end{array}$$

PROBLEM 6

A softball diamond is a square with sides of 60 feet. To the nearest whole number, how far is it from home plate to second base?

Answers to PROBLEMS

5. 20 in. 6. $\sqrt{7200} \approx 85$ ft

GREEN MATH

EXAMPLE 7 Distance in Central Park, New York

Find the distance between the two metro entrances (red line) in Central Park.

SOLUTION 7 We have to find the length of the hypotenuse c (red) of a triangle with sides of length $a = 2.6$ and $b = 0.5$.

$$\begin{aligned} \text{Substituting in } a^2 + b^2 = c^2 \text{ we obtain } (2.6)^2 + (0.5)^2 &= c^2 \\ 6.76 + 0.25 &= c^2 \end{aligned}$$

$$\begin{aligned} \text{Now, } 6.76 + 0.25 \text{ is very near } 7, \text{ so} & \quad 7 = c^2 \\ \text{and} & \quad \sqrt{7} = c \end{aligned}$$

Since $\sqrt{7} \approx 2.646$, the distance between the two metro entrances is about 2.6 miles.

PROBLEM 7

When measured in kilometers, the dimensions of the blue rectangle are 4.1 km by 0.83 km. What is the distance between the two metro entrances?



> Exercises 8.5



> Practice Problems > Self-Tests
> Media-rich eBooks > e-Professors > Videos

< A > Square Roots In Problems 1–10, find the square root of the number.

1. $\sqrt{100}$

2. $\sqrt{144}$

3. $\sqrt{196}$

4. $\sqrt{289}$

5. $\sqrt{361}$

6. $\sqrt{324}$

7. $\sqrt{400}$

8. $\sqrt{900}$

9. $\sqrt{169}$

10. $\sqrt{10,000}$

In Problems 11–20, approximate the answer to three decimal places.

11. $\sqrt{8}$

12. $\sqrt{10}$

13. $\sqrt{11}$

14. $\sqrt{17}$

15. $\sqrt{23}$

16. $\sqrt{27}$

17. $\sqrt{29}$

18. $\sqrt{33}$

19. $\sqrt{108}$

20. $\sqrt{405}$

Answers to PROBLEMS

7. $\sqrt{17.5} \approx 4.183 \approx 4.2$ kilometers

< B > The Pythagorean Theorem In Problems 21–30, find the hypotenuse c . Give the answer to three decimal places when appropriate.

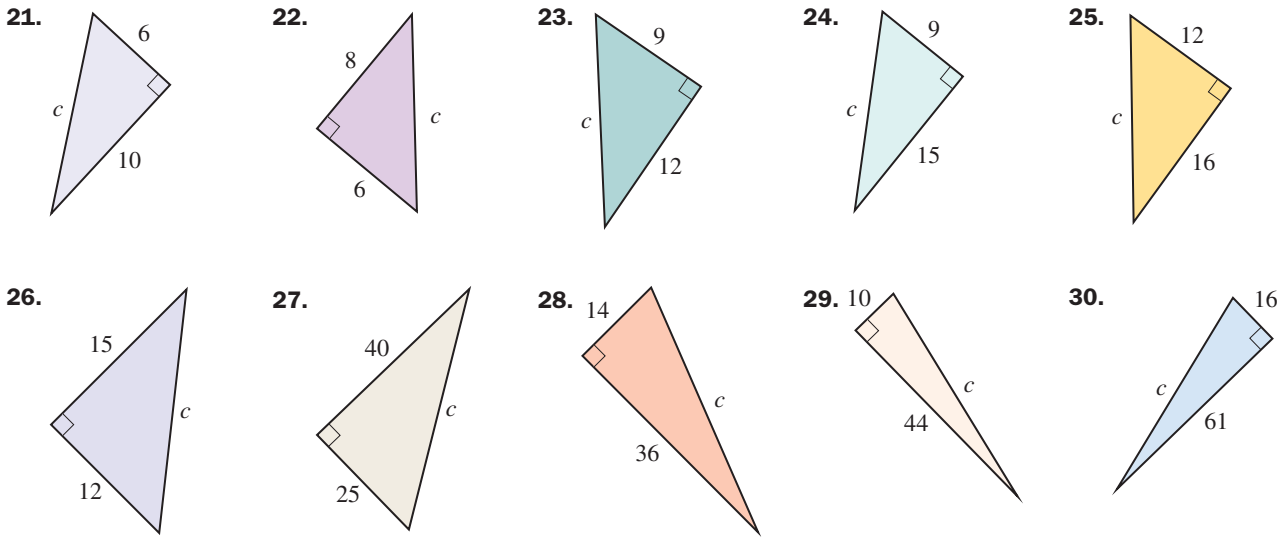

In Problems 31–38, find the missing side. Give the answer to three decimal places when appropriate.

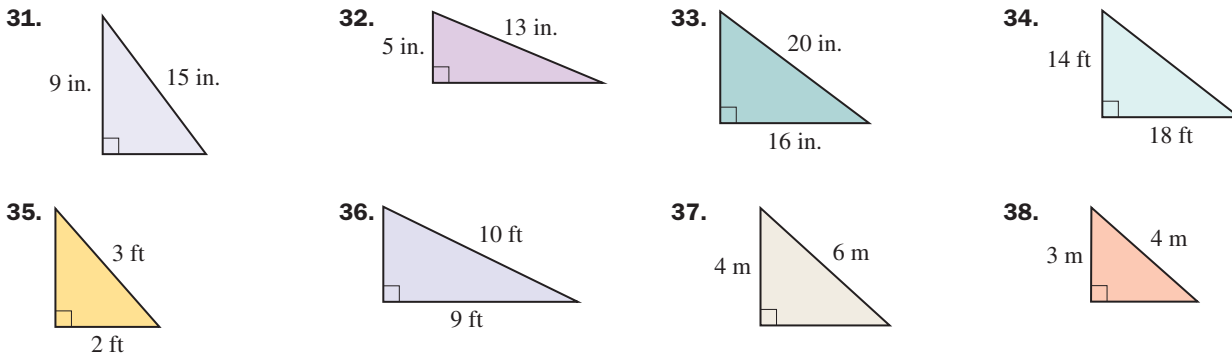

< C > Applications of the Pythagorean Theorem

39. Body measurements The diagram shows the distance from the hip to the knee ($b \approx 0.30$ m) and the distance from the knee to the ankle ($a \approx 0.44$ m). Use the Pythagorean theorem to find the distance (in meters m) from the hip to the ankle if the leg is bent at a right angle. Round the answer to the nearest thousandth.

40. Triangle dimensions *The Human Side of Mathematics* on page 479 shows a triangle like this one. If the dimensions of the triangle are as shown, find c and approximate it to two decimal places. Do you get the same answer as was shown in the *Getting Started*?

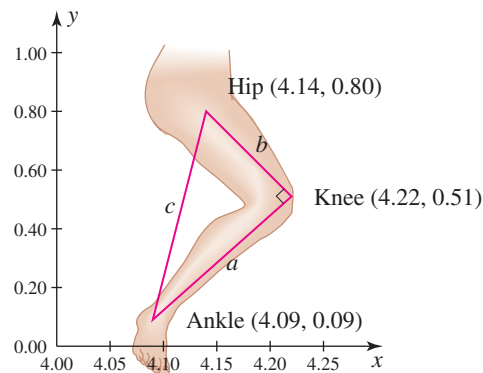
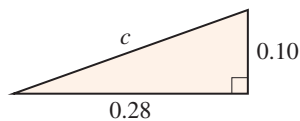

Source: Indiana University–Purdue University Indianapolis.

41. *Height of large television* One of the largest television sets ever built was the 289 Sony Jumbo Tron (289 feet diagonally!). If the length of the screen was 150 feet, what was the height? Round the answer to the nearest thousandth.
42. *Height of television* A 10-inch television screen (measured diagonally) is 8 inches wide. How high is it?

>>> Applications: Green Math

Dallas Stadium HD video displays

43. *EPA-approved stadium and HD TVs* Which is the biggest stadium recognized by the Environmental Protection Agency (EPA) National Environmental Performance Track Program, a program whose aims were to reduce energy, save fuel, clean the air, recycle solid waste, reduce the strain on local landfills, and conserve water? It is Dallas Stadium, home of the Dallas Cowboys. The stadium boasts the two biggest HD video displays in the world, each 160 feet wide and 72 feet high. What is the diagonal measurement of each video display? Round the answer to the nearest whole number.
44. *More video boards at Dallas Stadium* There are two smaller video boards at Dallas stadium each measuring 51 feet wide and 29 feet high. What is the diagonal measurement of each of the video boards? Round the answer to the nearest whole number.



45. *Length of jewel case* A rectangular DVD box is 14 centimeters wide and 11 centimeters high. What is the diagonal length of the box? Round the answer to the nearest thousandth.
46. *Length of a conveyor belt* Pedro Mendieta operates the conveyor belt machine used to haul materials to the top of the concrete mixing container. If the belt ends 40 feet above the ground, and starts 120 feet away from the base of the container, as shown in the photo, how long is the belt? Round the answer to the nearest foot.
47. *Length of a conveyor belt* Another conveyor belt machine operated by John Taylor ends 45 feet above the ground, but it starts 118 feet away from the base of the container as shown in the photo. How far do the materials travel to get to the top of the conveyor belt? Round the answer to the nearest foot.



48. *Airplane travel* The plane shown is ascending at a 10° angle. If the plane is 40 feet high, and the horizontal distance from the plane to the end of the runway is 220 feet as shown in the photo, how many feet has the plane traveled? Round the answer to the nearest foot.



49. *Bridges* The Dames Point Bridge spans the St. John River in Jacksonville, Florida. The longest cable supporting the bridge is 720 feet long and is secured 650 feet from the pole holding the cable as shown in the photo. What is the height h of the pole? Round the answer to the nearest whole number.
50. *Bridges* If in Problem 49 the cable was 700 feet long, how high would the pole be? Round the answer to the nearest whole number.

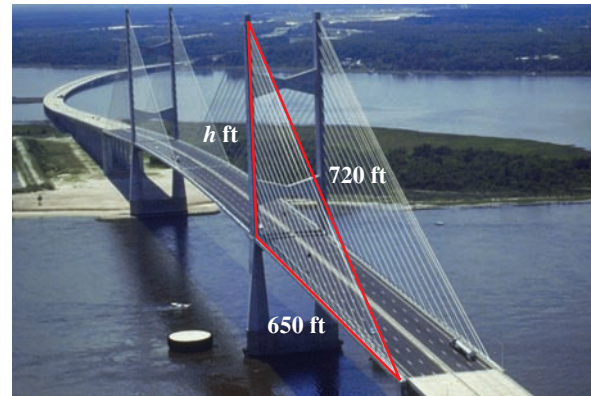

Using Your Knowledge

Approximation Suppose you want to approximate $\sqrt{18}$ without using your calculator. Since $\sqrt{16} = 4$ and $\sqrt{25} = 5$, you have $\sqrt{16} = 4 < \sqrt{18} < \sqrt{25} = 5$. This means that $\sqrt{18}$ is between 4 and 5. To find a better approximation of $\sqrt{18}$, you can use a method that mathematicians call **interpolation**. Don't be scared by this name! The process is *really* simple. If you want to find an approximation for $\sqrt{18}$, follow the steps in the diagram; $\sqrt{20}$ and $\sqrt{22}$ are also approximated.

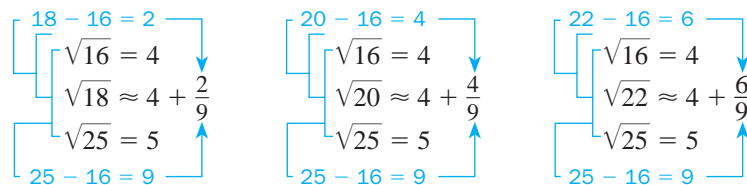

As you can see,

$$\sqrt{18} \approx 4\frac{2}{9} \quad \sqrt{20} \approx 4\frac{4}{9} \quad \text{and} \quad \sqrt{22} \approx 4\frac{6}{9} \approx 4\frac{2}{3}$$

By the way, do you see a pattern? What would $\sqrt{24}$ be?

Using a calculator, $\sqrt{18} \approx 4.2$ $\sqrt{20} \approx 4.5$ and $\sqrt{22} \approx 4.7$

Using approximations $\sqrt{18} = 4\frac{2}{9} \approx 4.2$, $\sqrt{20} = 4\frac{4}{9} \approx 4.4$ $\sqrt{22} = 4\frac{6}{9} \approx 4.7$

As you can see, we can get very close approximations!

Use this knowledge to approximate the following roots, giving the answer as a mixed number.

51. a. $\sqrt{26}$

b. $\sqrt{28}$

c. $\sqrt{30}$

52. a. $\sqrt{67}$

b. $\sqrt{70}$

c. $\sqrt{73}$

Write On

53. Squaring a number and finding the square root of a number are inverse operations. Can you find two other inverse operations?
54. Explain how you would prove or disprove that a given triangle is a right triangle.

Concept Checker

Fill in the blank(s) with the correct word(s), phrase, or mathematical statement.

55. In any **right triangle** with legs of length a and b and hypotenuse c , _____.

56. If a and b are the lengths of the legs of a triangle with hypotenuse c and $a^2 + b^2 = c^2$ then **the triangle must be** a _____ triangle.

$a^2 + b^2 = c^2$
scalene
right
isosceles

>>> Mastery Test

57. Find the length a for the given right triangle. Round the answer to the nearest thousandth.

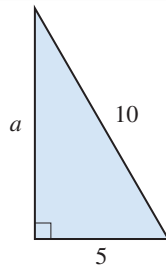

58. Find the hypotenuse for the given right triangle.

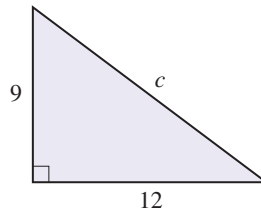

59. Find the hypotenuse for the given right triangle. Round the answer to the nearest thousandth.

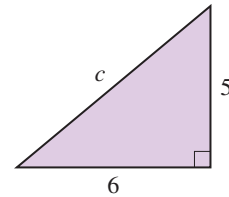

60. Find $\sqrt{1600}$.

61. Find $\sqrt{21}$ to three decimal places.

62. The diagonal of a computer monitor is 22 inches. If the monitor is 12 inches high, how wide is it? Round the answer to the nearest thousandth.

>>> Skill Checker

In Problems 63–67, subtract and check by addition.

63. $50 - 37$

64. $38 - 23$

65. $23 - 19$

66. $53 - 27$

67. $92 - 78$

> Collaborative Learning

Did you know that your hat size and your ring size are almost identical? By the way, there is a little flaw here. This is true only of men's hat sizes. Women's hat sizes are measured differently and more logically! Women's hat sizes are simply the circumference of the inner band of the hat. Nevertheless, we would like to see if there is a relationship between men's hat sizes—for men and women—and ring sizes. Form several groups of men and women.

1. Measure the circumference of the heads $C(H)$ of the participants.
2. Measure the circumference of their ring fingers $C(f)$.
3. Complete the following table, where $C(H)$ is the circumference of the head, $C(f)$ the circumference of the finger, d the diameter of the finger, H the men's hat size, and s the ring size.

$C(H)$	$\frac{C(H)}{\pi} = H$	$C(f)$	$\frac{C(f)}{\pi} = d$	$\frac{d - 0.458}{0.032} = s$

4. Is there a relationship between H and s ?
5. Is there a relationship between hat size and ring size for women? If so, what is it? ■

Research Questions



1. Many scholars ascribe the Pythagorean theorem to, surprise, Pythagoras! However, other versions of the theorem like the following exist:

The ancient Chinese proof Bhaskara's proof Euclid's proof
 Garfield's proof Pappus's generalization

Select three of these versions and write a paper giving details, if possible, about where they appeared, who authored them, and what was stated in each theorem.



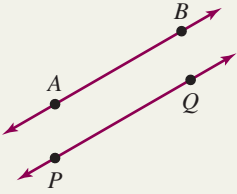
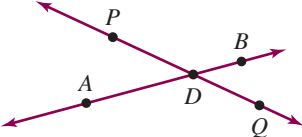

2. There are different versions of the death of Pythagoras. Write a short paper detailing the circumstances of his death, where it occurred, and how.
3. Write a report about Pythagorean triples.
4. The Pythagoreans studied arithmetic, music, geometry, and astronomy. Write a report about the Pythagoreans' theory of music.
5. Write a report about the Pythagoreans' theory of astronomy.

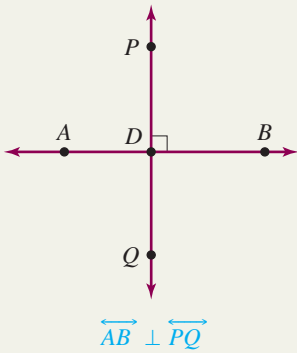
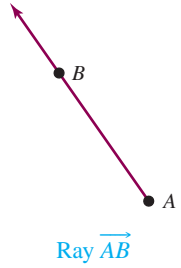
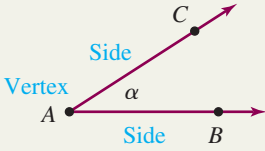
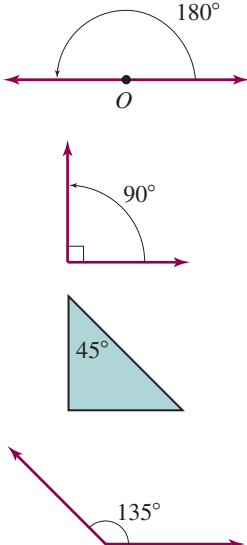
Summary Chapter 8

Section	Item	Meaning	Example
8.1A	Point	A location in space	$P\bullet$, $Q\bullet$, and $R\bullet$ are points.
8.1A	Line	A set of points that extends <i>infinitely</i> in both directions	 The line \overleftrightarrow{AB}
8.1A	Line segment	A piece of a line using A and B as endpoints	 Line segment \overline{AB}
8.1A	Parallel lines	Two lines in the same plane that extend <i>infinitely</i> in both directions and never intersect	 $\overleftrightarrow{AB} \parallel \overleftrightarrow{PQ}$
8.1A	Intersecting lines	Two lines with one common point	 \overleftrightarrow{AB} intersects \overleftrightarrow{PQ} at point D .

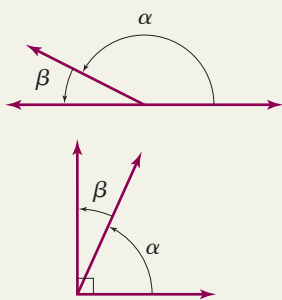
Section	Item	Meaning	Example
8.1A	Perpendicular lines	Two lines that intersect at right angles	
8.1A	Ray	A ray is part of a line with one <i>endpoint</i> and extending <i>infinitely</i> in one direction.	
8.1B	Angle Vertex of an angle Sides of an angle	The figure formed by two rays with a common endpoint called the vertex The common point of the two rays The rays forming the angle	
8.1C	Degree Straight angle Right angle Acute angle Obtuse angle	$\frac{1}{360}$ of a complete revolution One-half of a complete revolution One-quarter of a complete revolution An angle greater than 0° and less than 90° An angle greater than 90° and less than 180°	

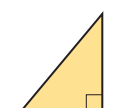
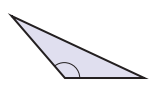
(continued)

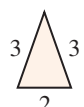
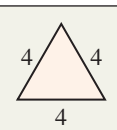
Section	Item	Meaning	Example
8.1D	Supplementary angles	Angles whose measures add to 180°	
	Complementary angles	Angles whose measures add to 90°	
8.1E	Acute triangle	All three angles are acute.	    
	Right triangle	One of the angles is a right angle.	
	Obtuse triangle	One of the angles is an obtuse angle.	
	Scalene triangle	No equal sides	
	Isosceles triangle	Two equal sides	
8.1E	Equilateral triangle	A triangle with three equal sides	
8.1F	Sum of the measures in a triangle	The sum of the measures in any triangle is 180° .	If in triangle ABC , $m\angle A = 50^\circ$ and $m\angle B = 60^\circ$, then $m\angle C = 180^\circ - 50^\circ - 60^\circ = 70^\circ$
8.2A	Perimeter Perimeter of a rectangle	Distance around $P = 2L + 2W$ (L = length, W = width)	The perimeter P of a rectangle 5 inches long and 3 inches wide is $P = 2 \cdot 5 \text{ in.} + 2 \cdot 3 \text{ in.} = 16 \text{ in.}$
	Perimeter of a square	$P = 4S$ (S = length of side)	The perimeter P of a square 3 centimeters on a side is $P = 4 \cdot 3 \text{ cm} = 12 \text{ cm.}$
8.2B	Circumference	$C = \pi d = 2\pi r$	The circumference of a circle of radius 6 centimeters is $2 \cdot \pi \cdot 6 \text{ cm} = 12\pi \text{ cm} \approx 37.68 \text{ cm.}$
8.3A	Area of a rectangle	$A = LW$ (L = length, W = width)	The area A of a rectangle 4 inches long and 2 inches wide is $A = 4 \text{ in.} \cdot 2 \text{ in.} = 8 \text{ in.}^2$.
	Area of a square	$A = S^2$	The area A of a square 5 centimeters on a side is $A = 5^2 \text{ cm}^2 = 25 \text{ cm}^2$.

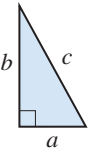
Section	Item	Meaning	Example
8.3B	Area of a triangle	$A = \frac{1}{2}bh$ (b = base, h = height)	The area A of a triangle of base 8 inches and height 10 inches is $A = \frac{1}{2} \cdot 8 \text{ in.} \cdot 10 \text{ in.} = 40 \text{ in.}^2$.
8.3C	Area of a parallelogram	$A = bh$ (b = base, h = height)	The area A of a parallelogram of base 10 centimeters and height 15 centimeters is $A = 10 \text{ cm} \cdot 15 \text{ cm} = 150 \text{ cm}^2$.
8.3D	Area of a trapezoid	$A = \frac{1}{2}h(a + b)$ (h = height, a and b are bases)	The area A of a trapezoid of height 8 centimeters and bases 6 centimeters and 10 centimeters, respectively, is $A = \frac{1}{2} \cdot 8 \text{ cm}(6 \text{ cm} + 10 \text{ cm}) = 64 \text{ cm}^2$.
8.3E	Area of a circle	$A = \pi r^2$ (r = radius)	The area of a circle of radius 6 centimeters is $\pi(6 \text{ cm})^2$, or $36\pi \text{ cm}^2 \approx 113 \text{ cm}^2$.
8.4A	Volume of a rectangular solid	$V = L \cdot W \cdot H$ (L = length, W = width, H = height)	The volume V of a rectangular box of length 5 meters, width 6 meters, and height 2 meters is $V = 5 \text{ m} \cdot 6 \text{ m} \cdot 2 \text{ m} = 60 \text{ m}^3$.
8.4B	Volume of a circular cylinder	$V = \pi r^2 h$ (r = radius, h = height)	The volume V of a circular cylinder of radius 3 inches and height 2 inches is $V = \pi \cdot (3 \text{ in.})^2 \cdot 2 \text{ in.} = 18\pi \text{ in.}^3 \approx 57 \text{ in.}^3$.
8.4C	Volume of a sphere	$V = \frac{4}{3}\pi r^3$ (r = radius)	The volume V of a sphere of radius 3 feet is $V = \frac{4}{3}\pi \cdot (3 \text{ ft})^3 = 36\pi \text{ ft}^3 \approx 113 \text{ ft}^3$.
8.4D	Volume of a circular cone	$V = \frac{1}{3}\pi r^2 h$ (r = radius, h = height)	The volume V of a circular cone of radius 2 centimeters and height 3 centimeters is $V = \frac{1}{3}\pi \cdot (2 \text{ cm})^2 \cdot 3 \text{ cm} = 4\pi \text{ cm}^3 \approx 13 \text{ cm}^3$.
8.4E	Volume of a pyramid	$V = \frac{1}{3}Bh$ (B = base area, h = height)	The volume V of a pyramid with each side measuring 3 feet with a height of 9 feet is $V = \frac{1}{3} \cdot 3 \text{ ft} \cdot 3 \text{ ft} \cdot 9 \text{ ft} = \frac{1}{3} \cdot 81 \text{ ft}^3 = 27 \text{ ft}^3$.
8.5A	$\sqrt{a} = b$	The square root of a is a number b so that $a = b^2$.	$\sqrt{9} = 3$ because $3^2 = 9$ $\sqrt{121} = 11$ because $11^2 = 121$
8.5B	Pythagorean theorem $c^2 = a^2 + b^2$	The square of the hypotenuse c of a right triangle equals the sum of the squares of the other two sides, a and b .	

Review Exercises Chapter 8

The figure will be used in Problems 1–5.

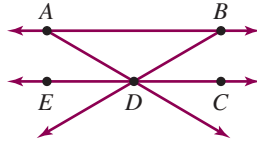

1. **< 8.1A >** Name a point in the figure.

- a. b.
c. d.
e.

2. **< 8.1A >** Name a line in the figure.

- a.
b.

3. **< 8.1A >** Name a line segment in the figure.

- a. b.
c. d.
e.

4. **< 8.1A >** Name a pair of parallel lines in the figure.

5. **< 8.1A >** Name a ray in the figure.

- a.
b.

6. **< 8.1B >** Name the angle in three different ways:

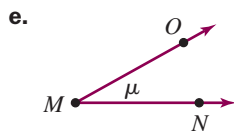
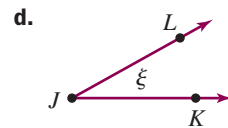
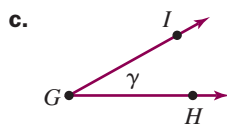
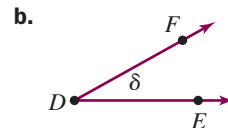
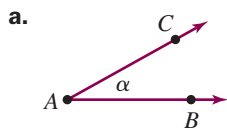

7. < 8.1C > Classify the angles as acute, right, straight, or obtuse.

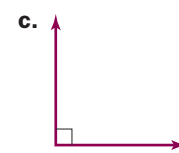
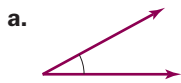

8. < 8.1D > Find the measure of the complement of a:

- a. 10° angle
- b. 15° angle
- c. 20° angle
- d. 30° angle
- e. 80° angle

9. < 8.1D > Find the measure of the supplement of a:

- a. 10° angle
- b. 15° angle
- c. 20° angle
- d. 30° angle
- e. 80° angle

10. < 8.1E > Classify the triangle according to the angles and sides.

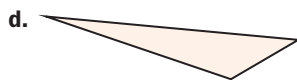
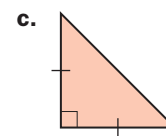
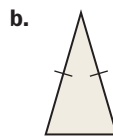
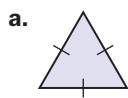

11. < 8.1F > Find $m \angle C$ in triangle ABC if:

- a. $m \angle A = 30^\circ$ and $m \angle B = 40^\circ$
- b. $m \angle A = 40^\circ$ and $m \angle B = 50^\circ$
- c. $m \angle A = 50^\circ$ and $m \angle B = 60^\circ$
- d. $m \angle A = 60^\circ$ and $m \angle B = 70^\circ$
- e. $m \angle A = 70^\circ$ and $m \angle B = 80^\circ$

12. < 8.2A > Find the perimeter of a rectangle:

- a. 5.1 meters long and 3.2 meters wide
- b. 4.1 centimeters long and 3.2 centimeters wide
- c. 3.5 inches long and 4.1 inches wide
- d. 5.2 yards wide and 4.1 yards long
- e. 4.1 feet wide and 6.2 feet long

13. < 8.2A > Find the perimeter of the polygon.

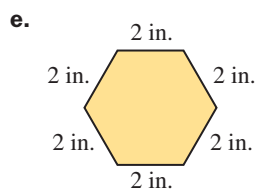
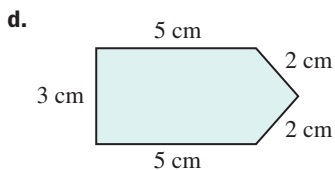
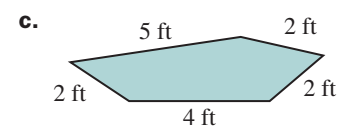
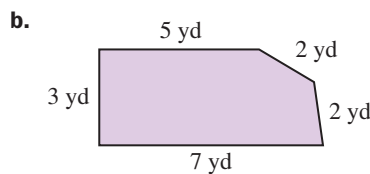
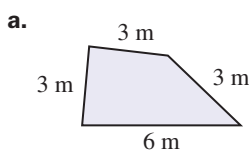

14. < 8.2B > Use 3.14 for π to find the circumference of a circle with radius:

- 6 cm
- 8 cm
- 10 in.
- 12 in.
- 14 ft

15. < 8.3A > Find the area of a rectangle:

- 5 m by 6 m
- 7 m by 8 m
- 4 in. by 6 in.
- 3 in. by 7 in.
- 9 in. by 12 in.

16. < 8.3B > Find the area of a triangle:

- With a 10-inch base and a 12-inch height
- With an 8-inch base and a 10-inch height
- With a 6-centimeter base and an 8-centimeter height
- With a 4-meter base and a 6-meter height
- With a 2-meter base and a 4-meter height

17. < 8.3C > Find the area of the parallelogram:

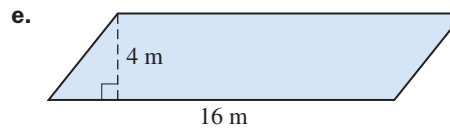
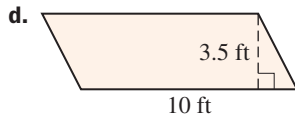
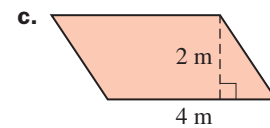
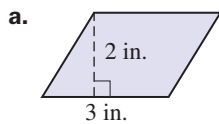

18. < 8.3D > Find the area of the trapezoid:

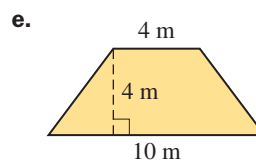
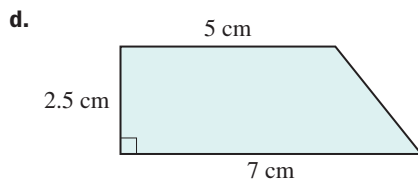
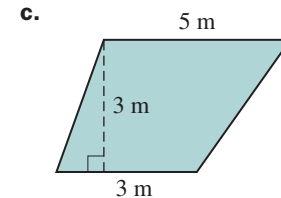
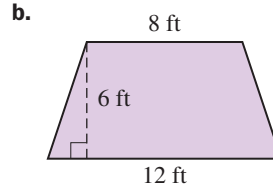
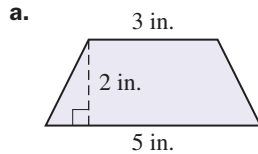

19. < 8.3E > Find the area of a circle with the given radius. Use 3.14 for π .

- 7 inches
- 1 centimeter
- 3 inches
- 2 feet
- 5 yards

20. < 8.4A > Find the volume of a box:

- 2 centimeters wide, 6 centimeters long, and 7 centimeters high
- 3 centimeters wide, 4 centimeters long, and 5 centimeters high
- 2 centimeters wide, 5 centimeters long, and 4 centimeters high
- 3 centimeters wide, 6 centimeters long, and 5 centimeters high
- 2 centimeters wide, 7 centimeters long, and 5 centimeters high

21. < 8.4B > Use 3.14 for π to find the volume (to the nearest hundredth) of a can in the shape of a circular cylinder with:

- A 1-inch radius and 6-inch height
- A 1-inch radius and 7-inch height
- A 1-inch radius and 8-inch height
- A 2-inch radius and 9-inch height
- A 2-inch radius and 10-inch height

- 22. < 8.4C >** Use 3.14 for π to find the volume (to the nearest hundredth) of a sphere with a radius of:
- 6 inches
 - 7 inches
 - 8 inches
 - 9 inches
 - 10 inches
- 23. < 8.4D >** Use 3.14 for π to find the volume (to the nearest hundredth) of a circular cone with:
- A 10-inch radius and 15-inch height
 - An 8-inch radius and 12-inch height
 - A 6-inch radius and 9-inch height
 - A 4-inch radius and 6-inch height
 - A 2-inch radius and 3-inch height
- 24. < 8.4E >** Find the volume of a pyramid 120 meters high and with a square base measuring:
- 210 meters on each side
 - 216 meters on each side
 - 220 meters on each side
 - 221 meters on each side
 - 225 meters on each side
- 25. < 8.5A >** Find:
- $\sqrt{25}$
 - $\sqrt{9}$
 - $\sqrt{121}$
 - $\sqrt{225}$
 - $\sqrt{169}$
- 26. < 8.5A >** Find to three decimal places:
- $\sqrt{2}$
 - $\sqrt{8}$
 - $\sqrt{12}$
 - $\sqrt{22}$
 - $\sqrt{17}$
- 27. < 8.5B >** Find the length of the hypotenuse of a right triangle whose sides measure:
- 5 cm and 12 cm
 - 4 cm and 3 cm
 - 9 cm and 12 cm
 - 12 cm and 16 cm
 - 15 cm and 20 cm
- 28. < 8.5B >** Find (to three decimal places) the length of the hypotenuse of a right triangle whose sides measure:
- 2 cm and 3 cm
 - 4 cm and 2 cm
 - 5 cm and 4 cm
 - 3 cm and 6 cm
 - 7 cm and 1 cm
- 29. < 8.5B >** Find (to three decimal places where necessary) the length of side a for a triangle:
- With hypotenuse 5 and side $b = 3$
 - With hypotenuse 8 and side $b = 4$
 - With hypotenuse 9 and side $b = 5$
 - With hypotenuse 10 and side $b = 6$
 - With hypotenuse 12 and side $b = 8$

Practice Test Chapter 8

(Answers on page 546)

Visit mhhe.com/bello to view helpful videos that provide step-by-step solutions to several of the problems below.

The figure will be used in Problems 1–5.

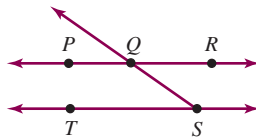

- Name three points in the figure.
- Name two lines in the figure.
- Name three line segments in the figure.
- Name a pair of lines that appear to be parallel in the figure.
- Name a ray in the figure.
- Name the angle three different ways.

7. Classify the angle:

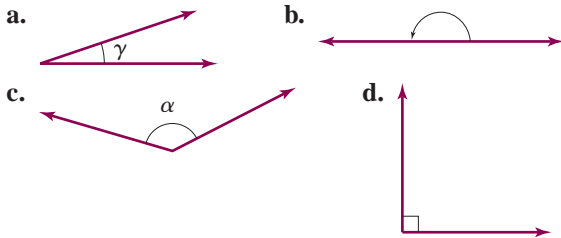

9. Classify the triangles according to their angles and sides.

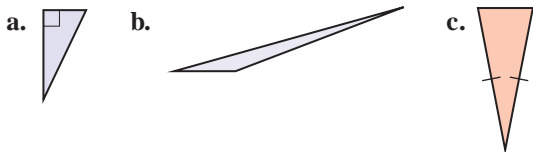

11. Find the perimeter of a rectangle 4.1 centimeters long by 2.3 centimeters wide.

13. Find the area of a rectangle 3 meters by 5 meters.

15. Find the area of the trapezoid.

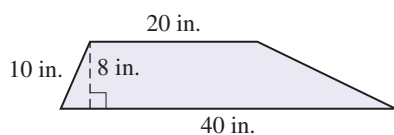

17. Find the volume of the box.

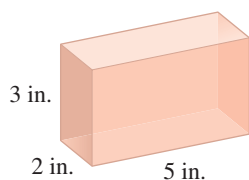

12. Find the circumference of a circle whose radius is 5 inches. (Use 3.14 for π .)

14. Find the area of a triangular piece of cloth that has a 10-centimeter base and is 10 centimeters high.

16. Find the area of a circle with a radius of 4 centimeters. (Use 3.14 for π .)

18. Find the volume of a cylinder 6 inches high and with a 3-inch radius. Use 3.14 for π and give the answer to two decimal places.

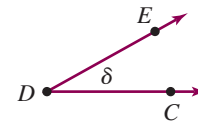

8.

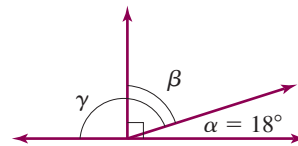

If $m \angle \alpha = 18^\circ$

- What is the measure of the complement of α ? Name the complement of α .
 - What is the measure of the supplement of α ? Name the supplement of α .
10. In a triangle ABC , $m \angle A = 47^\circ$, $m \angle B = 53^\circ$. Find $m \angle C$.

19. Find the volume of a sphere with a 6-inch radius. Use 3.14 for π and give the answer to two decimal places.

21. Find $\sqrt{3600}$.

23. Find the length of the hypotenuse c .

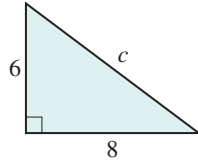

25. The diagonal length of a television screen is 15 inches. If the width is 12 inches, how high is it?

20. Find the volume of a cone 9 inches high and with a 6-inch radius. Use 3.14 for π and give the answer to two decimal places.

22. Find $\sqrt{6}$ (give the answer to three decimal places).

24. Find the length of a .

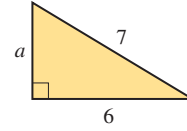

> Answers to Practice Test Chapter 8

Answer	If You Missed		Review	
	Question	Section	Examples	Page
1. Pick any three: P , Q , and R for example.	1	8.1	1a	483
2. \overrightarrow{PR} and \overrightarrow{TS}	2	8.1	1b	483
3. \overrightarrow{PQ} , \overrightarrow{QR} , and \overrightarrow{TS}	3	8.1	1c	483–484
4. \overrightarrow{PR} and \overrightarrow{TS} appear to be parallel	4	8.1	1d	483–484
5. \overrightarrow{SQ}	5	8.1	1e	483–484
6. $\angle\delta$, $\angle D$, $\angle CDE$ (or $\angle EDC$)	6	8.1	2	484
7. a. Acute b. Straight c. Obtuse d. Right	7	8.1	3, 4	485–486
8. a. 72° ; β b. 162° ; γ	8	8.1	6, 7	487
9. a. Right scalene b. Obtuse scalene c. Acute isosceles	9	8.1	8	489
10. 80°	10	8.1	9	490
11. 12.8 cm	11	8.2	1, 2, 3, 4	499–500
12. 31.4 in.	12	8.2	7, 8	501–502
13. 15 m^2	13	8.3	1, 2	507
14. 50 cm^2	14	8.3	3	508
15. 240 in.^2	15	8.3	5	509
16. 50.24 cm^2	16	8.3	6, 7	510
17. 30 in.^3	17	8.4	1, 2	517–518
18. 169.56 in.^3	18	8.4	3	518
19. 904.32 in.^3	19	8.4	4	519
20. 339.12 in.^3	20	8.4	5	520
21. 60	21	8.5	1	528
22. 2.449	22	8.5	2	528
23. $c = 10$	23	8.5	3	529
24. $a = \sqrt{13} \approx 3.606$	24	8.5	4	529
25. 9 in.	25	8.5	5, 6, 7	530–531

> Cumulative Review Chapters 1–8

1. Simplify: $9 \div 3 \cdot 3 + 5 - 4$
2. Subtract: $745.42 - 17.5$
3. Round 749.851 to the nearest ten.
4. Divide: $40 \div 0.13$ (Round answer to two decimal places.)
5. Solve for y : $3.6 = 0.6y$
6. Solve for z : $4 = \frac{z}{4.4}$
7. Solve the proportion: $\frac{j}{5} = \frac{5}{125}$
8. Write 89% as a decimal.
9. 50% of 90 is what number?
10. What percent of 24 is 6?
11. 18 is 30% of what number?
12. Find the simple interest earned on \$600 invested at 6.5% for 2 years.
13. Referring to the circle graph, which is the main source of pollution?
14. Make a circle graph for this data:

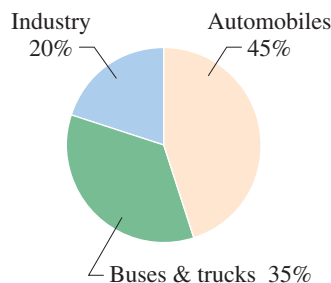

Family Budget (Monthly)

Savings (S)	\$200
Housing (H)	\$900
Food (F)	\$400
Clothing (C)	\$500

15. The following table shows the distribution of families by income in Portland, Oregon.
16. The following graph represents the monthly average temperature for seven months of the year. How much higher is the average temperature in July than it is in May?

Income Level	Percent of Families
\$0–9,999	3
10,000–14,999	10
15,000–19,999	27
20,000–24,999	34
25,000–34,999	12
35,000–49,999	6
50,000–79,999	4
80,000–119,999	3
120,000 and over	1

What percent of the families in Portland have incomes between \$10,000 and \$14,999?

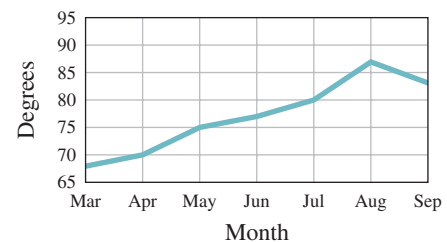

- 17.** The number of hours required in each discipline of a college core curriculum is represented by the following circle graph. What percent of these hours is in Math and English combined?

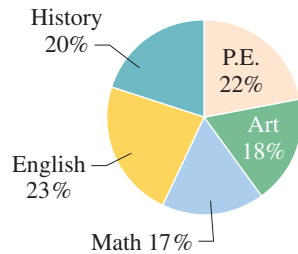

- 19.** What is the mean of the following numbers?
5, 7, 27, 24, 27, 27, 27, 18, 25, 6, 27
- 21.** Convert 11 yards to inches.
- 23.** Convert 7 feet to yards.
- 25.** Convert 4 kilometers to meters.
- 27.** Convert 140 meters to decimeters.
- 29.** Find the perimeter of a rectangle 5.1 inches long by 2.8 inches wide.
- 31.** Find the area of a triangular piece of cloth with a 20-centimeter base and 12-centimeter height.
- 33.** Find the area of the trapezoid.

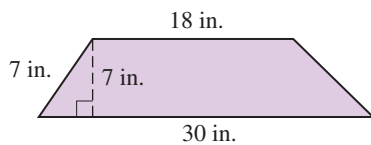

- 35.** Find the volume of a sphere with a 6-inch radius. Use 3.14 for π and give the answer to two decimal places.
- 37.** If in triangle ABC , $m \angle A = 20^\circ$, and $m \angle B = 35^\circ$, what is $m \angle C$?
- 39.** Find the hypotenuse c of the given triangle:

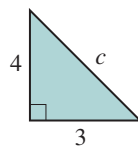

- 18.** What is the mode of the following numbers?

1, 18, 5, 18, 9, 8, 26, 28, 18, 7

- 20.** What is the median of the following numbers?
4, 21, 22, 23, 4, 15, 23, 11, 25, 23, 16
- 22.** Convert 9 inches to feet.
- 24.** Convert 5 feet to inches.
- 26.** Convert 2 dekameters to meters.
- 28.** Find the area in square yards of a 10-acre lot.
- 30.** Find the circumference of a circle whose radius is 6 centimeters. (Use 3.14 for π .)
- 32.** Find the area of a circle with a radius of 8 centimeters. (Use 3.14 for π .)
- 34.** Find the volume of a box 2 centimeters wide, 4 centimeters long, and 9 centimeters high.

- 36.** Classify the angle:

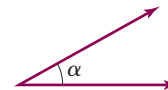

- 38.** Find $\sqrt{3600}$.

Section

Chapter

- 9.1 Addition and Subtraction of Integers
- 9.2 Multiplication and Division of Integers
- 9.3 The Rational Numbers
- 9.4 Order of Operations

9

nine

▶ The Real Numbers

The Human Side of Mathematics

We have already studied the natural or counting numbers 1, 2, 3, and so on, but these numbers are not enough for the needs of everyday life. We need to measure subzero temperatures, yardage losses in football games, and financial losses in the stock market. We need **negative numbers!** Who invented and used these numbers and when? Here is a partial answer.

China: Negative numbers were used since the first century. On their calculation tables, black rods represented negative numbers and red rods positive ones.

India: Negative numbers were used by the **Indian mathematicians** (Hindu) of the sixth and seventh centuries. For example, **Bramagupta** (seventh century) taught the way of making additions and subtractions on goods, debts, and nothingness. “A *debt cut off from nothingness becomes a good, a good cut off from nothingness becomes a debt.*”

Italy: Negative numbers were used at the end of the fifteenth century as solutions for equations. For example, the writings of the Italian mathematician Girolamo Cardan (1501–1576) included negative numbers.

But the story does not end there. Dividing one integer by another yields a new number, a **rational** number. These numbers (which we also call fractions) can also be written as decimals. We might imagine that our numerical journey ends with the rational numbers. However, the Pythagoreans, a secret society of scholars in ancient Greece (ca. 540–500 B.C.), made a stunning discovery: the **irrational** numbers ($\sqrt{2}$ and π are irrational). These numbers defied their knowledge of number properties because they could not be written as the ratio of two whole numbers. We use the rationals and irrationals in a new set of numbers called the **real** numbers.

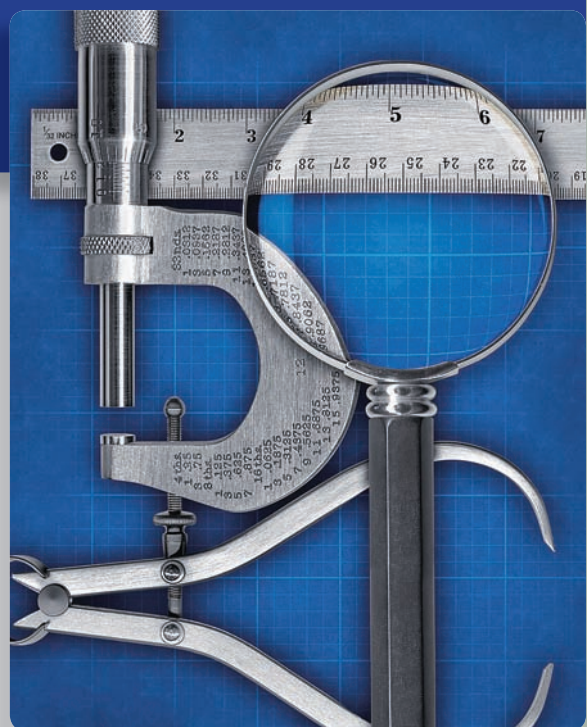

9.1

Addition and Subtraction of Integers

▶ Objectives

You should be able to:

- A > Classify, use, represent, graph, and compare integers.
- B > Find the additive inverse (opposite) of an integer.
- C > Find the absolute value of an integer.
- D > Add two integers using a number line.
- E > Add two integers using the rules given in the text.
- F > Subtract integers by adding additive inverses.
- G > Solve applications involving integers.

▶ To Succeed, Review How To . . .

1. Construct a number line containing the whole numbers. (pp. 14–15)
2. Check a subtraction problem by addition. (p. 38)

▶ Getting Started

In the cartoon below, Linus is trying to subtract six from four. He wants to find

$$4 - 6 = \square$$

As you recall, $4 - 6 = \square$ can be written as

$$4 = 6 + \square$$

We cannot find a *whole* number \square that when added to 6 will give us 4. Let us think about it this way. Say you are in a poker game. You win \$6 and then added to this you lose \$2. You are still winning \$4. Therefore,

$$6 + \boxed{-2} = 4$$

Thus a *loss* of \$2 is written as -2 , and a *gain* of \$6 is written as 6 (or $+6$ if you prefer). The number -2 is called a **negative** number. Here are some other quantities that can be measured using negative numbers:

- 10 degrees below zero: -10°
- a loss of \$5: $-\$5$
- 15 feet below sea level: -15 feet

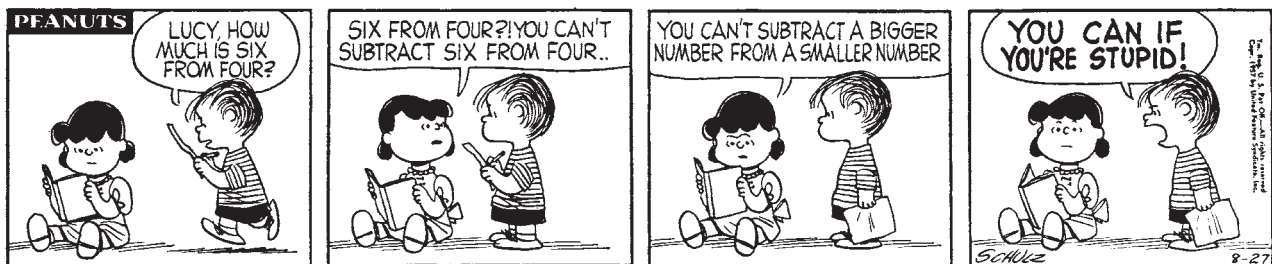

Peanuts: © United Features Syndicate, Inc.

A > Introduction to the Integers

In the *Getting Started* we have added an important concept to the idea of a number: the concept of direction. To visualize this we draw a straight line, choose a point on this line, and label it 0, the **origin**. (See Figure 9.1.) We then measure successive equal intervals to the

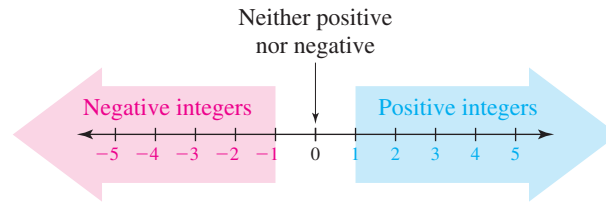

>Figure 9.1

right of 0 and label the division points with the **positive integers** (natural or **counting** numbers) in their order, 1, 2, 3, Note that the positive integers can be written as 1, 2, 3, . . . , or as +1, +2, +3, We usually write 1 instead of +1, 2 instead of +2, and so on. Similarly, the points to the *left* of 0, the **negative integers**, are labeled $-1, -2, -3, \dots$ (read “negative one, negative two, negative three, and so on”). Note that 0 is neither positive nor negative.

We have drawn our line a little over five units long on each side. The arrows at either end indicate that the line could be drawn to any desired length.

The **positive** and the **negative** numbers are collectively called **signed** numbers. Why? Because we identify the **positive** numbers with the + (**plus**) sign and **negative** numbers with the - (**negative**) sign. Note that we **do not** use the minus sign ($-$), which is reserved for the operation of *subtraction*. What about 0? The number 0 is neither positive nor negative. Based on this discussion we introduce a new set of numbers called the **integers**. The set of integers consists of

1. The positive numbers $\{1, 2, 3, \dots\}$.
2. The number 0.
3. The negative numbers $\{\dots -3, -2, -1\}$.

Thus, the set of integers is $I = \{\dots -3, -2, -1, 0, 1, 2, 3 \dots\}$.

To do Example 1, recall that the set of natural numbers is $N = \{1, 2, 3, \dots\}$ and the set of whole numbers is $W = \{0, 1, 2, 3, \dots\}$.

EXAMPLE 1 Classifying numbers

Which numbers in the set $\{-5, -4, 0, 1, 2, 3\}$ are

- a. Natural numbers?
- b. Whole numbers?
- c. Positive integers?
- d. Negative integers?
- e. Integers?

SOLUTION 1

- a. The natural numbers in the set are 1, 2, and 3.
- b. The whole numbers in the set are 0, 1, 2, and 3.
- c. The positive integers in the set are 1, 2, and 3.
- d. The negative integers in the set are -5 and -4 .
- e. The integers in the set are $-5, -4, 0, 1, 2$, and 3.

PROBLEM 1

Which numbers in the set $\{-3, -1, 0, 4, 5, 7\}$ are

- a. Natural numbers?
- b. Whole numbers?
- c. Positive integers?
- d. Negative integers?
- e. Integers?

Answers to PROBLEMS

1. a. 4, 5, 7 b. 0, 4, 5, 7
 c. 4, 5, 7 d. $-3, -1$
 e. $-3, -1, 0, 4, 5, 7$

The integers can be used in many situations. Some of these situations are illustrated in Example 2.

EXAMPLE 2 Uses of integers

Describe how the integers are used based on the following figures.

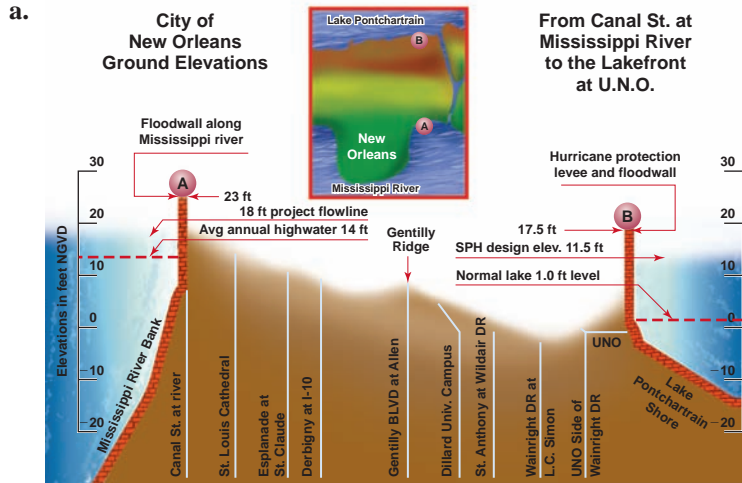

Source: <http://www.publichealth.hurricane.lsu.edu>.

b.

Golf: Best-Ball Stroke Play			
Pos	Name	Thru	Total
1	Sue/Fred	5	-2
2	Al/Bob	2	-1
3	Cal/Don	2	E
4	Mike/Tami	5	+1

Source: <http://www.motherhensw.com>.

SOLUTION 2

- a. Indicates elevations in New Orleans
- b. The integers indicate golf scores.

PROBLEM 2

Describe how the integers are used in the following diagram.

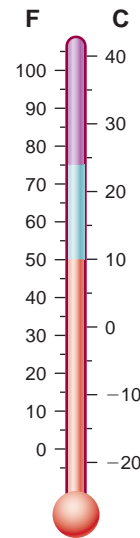

PROBLEM 3

Represent a real-world situation using integers.

- a. The national debt is \$8,391,014,420,537.
- b. The height of the Empire State Building and its lightning rod is 1454 feet.
- c. The elevation of the Dead Sea is 408 meters below sea level.

SOLUTION 3

- a. -\$50 and +\$30 (or simply \$30)
- b. +1052 feet (or simply 1052 feet)
- c. -282 feet

In Figure 9.1, we have a picture of a number line. We can graph individual integers on a number line as we did in Section 1.2. We illustrate how in Example 4.

Answers to PROBLEMS

- 2. The integers indicate temperatures in degrees Celsius or Fahrenheit.
- 3. a. -\$8,391,014,420,537 (this is more than 8 trillion dollars in debt!) b. +1454 ft (or 1454 ft) c. -408 m

EXAMPLE 4 Graphing integers

Graph the integers $-3, 0,$ and 5 on a number line.

SOLUTION 4

Draw a number line with equally spaced points, as in Figure 9.1. To graph -3 place a heavy dot on the number line above -3 .

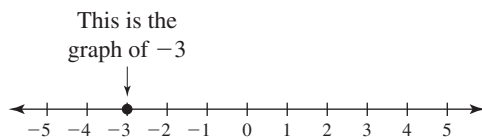

Do the same for 0 and 5 .



PROBLEM 4

Graph the integers $-4, 1,$ and 3 on a number line.

In Chapter 1 we used the symbols $<$ (less than) and $>$ (greater than) to compare numbers. We can use the same symbols to compare integers using a number line.

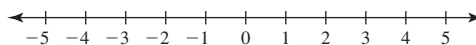

As you can see, the integers are written *in order* and they increase as you move from left to right on the number line, so any integer is always **greater than** ($>$) any other integer to its left and is **less than** ($<$) any integer to its right. Here is the definition we need:

LESS THAN ($<$) AND GREATER THAN ($>$)

If a and b are two integers, a is less than b if a lies to the left of b on the number line. In symbols, $a < b$.

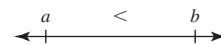

This also means that b is to the right of a . That is, b is greater than a . In symbols, $b > a$.

EXAMPLE 5 Comparing integers

Graph the integers and insert the symbol $<$ or $>$ to make the statement true.

a. $-2 \underline{\hspace{1cm}} -5$

b. $1 \underline{\hspace{1cm}} 3$

SOLUTION 5

a. Draw a number line and graph -2 and -5 , as shown.

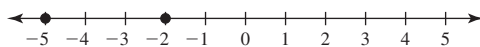

$-2 > -5$, since -2 is to the right of -5 . Thus, $-2 \underline{>} -5$.

b. Draw a number line and graph 1 and 3 .

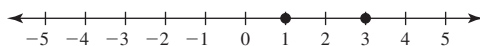

$1 < 3$, since 1 is to the left of 3 . Thus, $1 \underline{<} 3$.

PROBLEM 5

Graph the integers and insert the symbol $<$ or $>$ to make the statement true.

a. $-4 \underline{\hspace{1cm}} -1$ b. $2 \underline{\hspace{1cm}} 0$

Answers to PROBLEMS

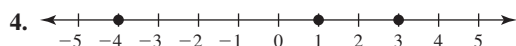

a. $-4 \underline{<} -1$ b. $2 \underline{>} 0$

B > Additive Inverses

For every *positive* integer, there is a corresponding *negative* integer. Thus, associated with the positive integer 3, we have the negative integer -3 . Since -3 and 3 are the same distance from the origin but in opposite directions, 3 and -3 are called **opposites**, **additive inverses**, or simply **inverses**. Similarly, the additive inverse (opposite) of 2 is -2 , and the additive inverse (opposite) of -1 is 1, as shown in Figure 9.2

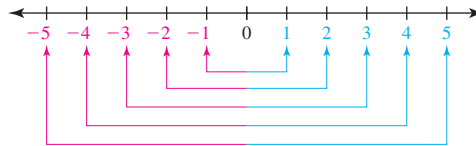

>Figure 9.2

Thus for every positive integer there is a corresponding negative integer.

3 and -3 are additive inverses (opposites).

-1 and 1 are additive inverses (opposites).

If we follow a pattern to find inverses (opposites) we have

Integer	Additive Inverse
3	-3
2	-2
-1	$-(-1) = 1$
-2	$-(-2) = 2$

In general,

ADDITIVE INVERSE OF A NUMBER

The inverse of a nonzero number a is $-a$ and the inverse of $-a$ is $-(-a) = a$.
The inverse of 0 is 0, since $0 = -0$.

EXAMPLE 6 Finding the additive inverse

Find the additive inverse.

- a. 9 b. -7

SOLUTION 6

- a. The additive inverse of 9 is -9 .
b. The additive inverse of -7 is $-(-7) = 7$.

PROBLEM 6

Find the additive inverse.

- a. 17 b. -17

C > Absolute Value

Now, let us go back to the number line. What is the distance between 3 and 0? The answer is 3 units.

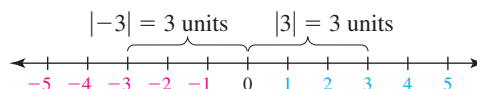

What is the distance between -3 and 0? The answer is still 3 units.

Answers to PROBLEMS

6. a. -17 b. 17

The distance between any number n and 0 is called the **absolute value** of the number and is denoted by $|n|$. Thus, $|-3| = 3$ and $|3| = 3$. Note that since the absolute value represents a *distance*, the absolute value of a number is *never* negative.

ABSOLUTE VALUE OF A NUMBER

The absolute value of a number n is its distance from 0 and is denoted by $|n|$.

In general,

$$|n| = \begin{cases} n, & \text{if } n > 0 \\ 0, & \text{if } n = 0 \\ -n, & \text{if } n < 0 \end{cases}$$

EXAMPLE 7 Absolute value of an integer

Find the absolute value.

a. $|-6|$

b. $|7|$

c. $|0|$

SOLUTION 7

a. $|-6| = 6$ -6 is 6 units from 0.

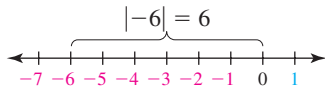

b. $|7| = 7$ 7 is 7 units from 0.

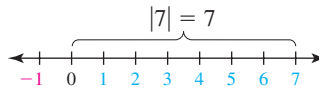

c. $|0| = 0$ 0 is 0 units from 0.

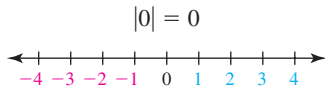

PROBLEM 7

Find the absolute value.

a. $|-18|$

b. $|8|$

c. $|-0|$

D > Addition of Integers Using a Number Line

We are now ready to do addition using the number line. Here is the procedure to do it.

TO ADD $a + b$ ON THE NUMBER LINE

1. Start at 0 and move to a (to the right if a is positive, to the left if negative).
2.
 - a. If b is positive, move right b units.
 - b. If b is negative, move left b units.
 - c. If b is zero, stay at a .

For example, the sum $2 + 3$, or $(+2) + (+3)$, is found by moving 2 units to the right, followed by 3 more units to the right. Thus, $2 + 3 = 5$, as shown in Figure 9.3.

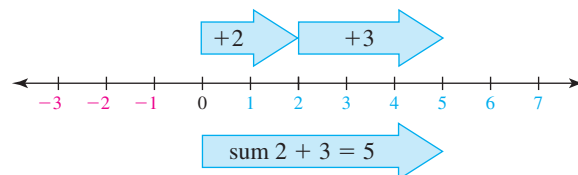

>Figure 9.3

Answers to PROBLEMS

7. a. 18 b. 8 c. 0

EXAMPLE 8 Adding integers

Add: $5 + (-2)$

SOLUTION 8 First move 5 units to the right, followed by 2 units to the left. The end result is 3. Thus $5 + (-2) = 3$, as shown in Figure 9.4.

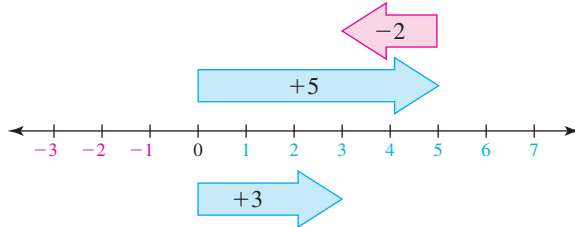

>Figure 9.4

PROBLEM 8

Add: $4 + (-3)$

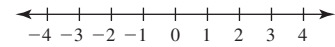

EXAMPLE 9 Adding integers

Add: $-5 + 3$

SOLUTION 9 First move 5 units to the left, followed by 3 units to the right. The end result is -2 as shown in Figure 9.5. Thus, $-5 + 3 = -2$.

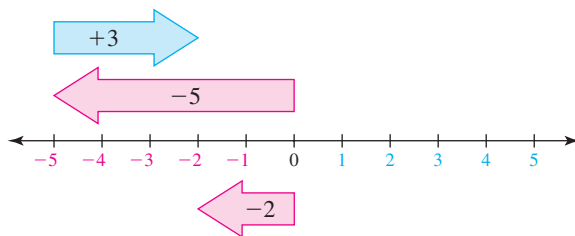

>Figure 9.5

PROBLEM 9

Add: $-3 + 1$

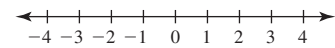

Can we add two negative integers? Of course. However, we have to be careful when writing such problems. For example, to add -3 and -2 we should write

$$-3 + (-2)$$

The parentheses are needed because

$$-3 + -2$$

is confusing.

CAUTION

Never use two signs together without parentheses.

EXAMPLE 10 Adding integers

Add: $-3 + (-2)$

PROBLEM 10

Add: $-2 + (-1)$

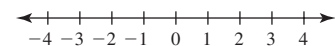

Answers to PROBLEMS

8.

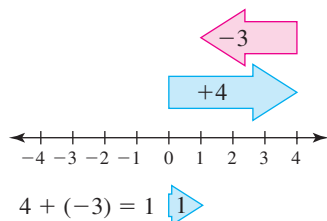

9.

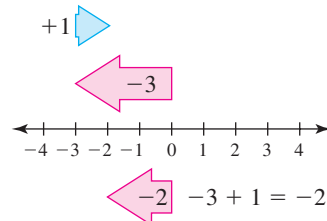

10.

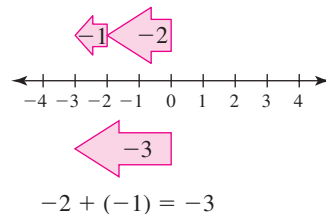

SOLUTION 10 First move 3 units left, followed by 2 more units left. The result is 5 units to the left; that is, $-3 + (-2) = -5$.

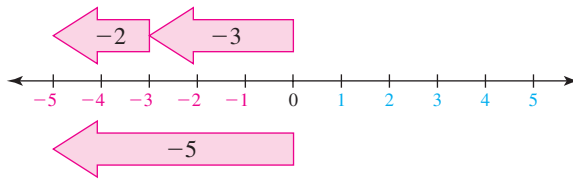

E > Adding Integers Using Addition Rules

As you have seen from these examples, if we add numbers with the *same* sign, the result is a number with this sign. Thus, $2 + 3 = 5$ and $-3 + (-2) = -5$. If we add numbers with *opposite* signs, the answer carries the sign of the number with the larger *absolute value*; thus,

$$5 + (-2) = 3 \quad \text{but} \quad -5 + 2 = -3$$

Here is the rule summarizing this discussion:

TO ADD INTEGERS

1. If both numbers have the *same* sign, add their absolute values and give the sum the common sign.
2. If the numbers have *opposite* signs, subtract their absolute values and give the difference the sign of the number with the greater absolute value.

Thus, $3 + 7 = 10$, $4 + 9 = 13$, $-3 + (-7) = -10$, and $-4 + (-9) = -13$. To add $-8 + 5$ we first notice that the numbers have *opposite* signs. So we subtract their absolute values and give the difference the sign of the number with the greater absolute value. Thus,

$$-8 + 5 = -(8 - 5) = -3$$

Use the sign of the larger integer. Subtract the smaller integer from the larger one.

(You can think about this problem in another way. You are adding a negative to a positive, but you have more negatives, so the answer is negative. How many more negatives do you have? 3, so the answer is -3 .) Similarly,

$$+8 + (-5) = +(8 - 5) = 3$$

Use the sign of the larger integer. Subtract the smaller integer from the larger one.

EXAMPLE 11 Adding integers

Add:

- a. $-8 + (-6)$ b. $-10 + 6$
 c. $10 + (-6)$ d. $10 + (-3) + 8 + (-2)$

PROBLEM 11

Add:

- a. $-9 + (-4)$
 b. $-17 + 8$
 c. $17 + (-8)$
 d. $12 + (-4) + 5 + (-3)$

(continued)

Answers to PROBLEMS

11. a. -13 b. -9 c. 9 d. 10

SOLUTION 11

- a. $-8 + (-6) = -(8 + 6) = -14$
 b. $-10 + 6 = -(10 - 6) = -4$
 c. $10 + (-6) = 10 - 6 = 4$
 d. We add the positives 10 and 8 and the negatives (-3) and (-2) , then add the results like this

$$10 + (-3) + 8 + (-2)$$

$$18 + (-5) = 13$$

F > Subtracting Integers

We are now ready to subtract integers. Suppose a bank uses positive integers to indicate deposits and negative integers to indicate withdrawals. If you deposit \$4 and then withdraw \$6, you owe \$2. Thus

$$4 - 6 = 4 + (-6) = -2$$

Also,

$$-4 - 3 = -4 + (-3) = -7$$

because if you owe \$4 and then withdraw \$3 more, you now owe \$7. These results can be checked using the definition of subtraction of integers.

DEFINITION OF SUBTRACTION

The difference $a - b = c$ means $a = b + c$.

Thus, $4 - 6 = -2$ because $4 = 6 + (-2)$, and $-4 - 3 = -7$ because $-4 = 3 + (-7)$.

What about $5 - (-2)$? We claim that $5 - (-2) = 7$ because if you deposit \$5 and the bank cancels (subtracts) a \$2 debt (represented by -2), your account *increases* by \$2. Thus, $5 - (-2) = 5 + 2 = 7$. Note that

$$4 - 6 = 4 + (-6)$$

$$-4 - 3 = -4 + (-3)$$

$$5 - (-2) = 5 + 2$$

In general, we have the following rule for subtracting integers.

TO SUBTRACT INTEGERS

For any real numbers a and b ,

$$a - b = a + (-b)$$

To *subtract* an integer b , *add* its opposite $(-b)$.

Note that the opposite of $-a$ is a , that is, $-(-a) = a$.

Thus,

$$3 - 7 = 3 + (-7) = -4$$

$$9 - 3 = 9 + (-3) = 6$$

$$-8 - 3 = -8 + (-3) = -11$$

$$-8 - (-4) = -8 + 4 = -4$$

EXAMPLE 12 Subtracting integers

Subtract:

a. $15 - 6$

b. $-20 - 3$

c. $-10 - (-8)$

d. $8 - 13$

e. $4 - (-5) - 3 + 7$

SOLUTION 12

a. $15 - 6 = 15 + (-6) = +(15 - 6) = 9$

b. $-20 - 3 = -20 + (-3) = -(20 + 3) = -23$

c. $-10 - (-8) = -10 + 8 = -(10 - 8) = -2$

d. $8 - 13 = 8 + (-13) = -(13 - 8) = -5$

e. Use the definition of subtraction to write as an addition problem, then add the positives together and the negatives together:

$$\begin{aligned} & 4 - (-5) - 3 + 7 \\ &= 4 + 5 + (-3) + 7 \\ &= \underbrace{4 + 5 + (-3)} + 7 \\ &= 16 + (-3) \\ &= 13 \end{aligned}$$

PROBLEM 12

Subtract:

a. $13 - 7$

b. $-18 - 4$

c. $-3 - (-9)$

d. $7 - 15$

e. $5 - (-8) - 6 + 9$

G > Applications Involving Integers

What would happen if the Earth's temperature increased by several degrees Celsius? There would be extra beach erosion; intensified flooding; and the salinity of rivers, bays, and groundwater would increase. The graph shows temperature changes from 0 to 2.5 degrees Celsius between the years 1990 and 2100 under five different sets of conditions for reducing carbon emissions: Carry on as usual, Implement Kyoto Protocol, Stabilize Emissions at 2000 levels, Reduce Emissions by 25%, and Reduce Emissions by 75%.

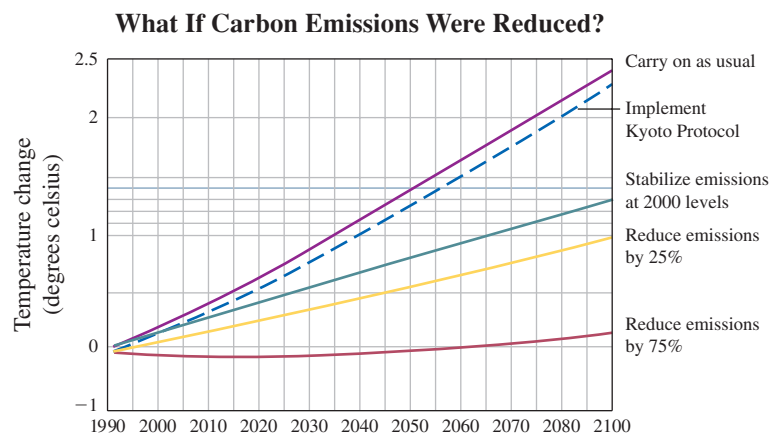
**Answers to PROBLEMS**

12. a. 6 b. -22

c. 6 d. -8 e. 16

GREEN MATH

EXAMPLE 13 Temperature changes under different conditions

- If we “carry on as usual,” in what year will the temperature go up by 2 degrees Celsius (2°C)?
- If we “Implement the Kyoto Protocol,” in what year will the temperature go up by 1 degree Celsius (1°C)?

SOLUTION 13

- The curve corresponding to “Carry on as usual” is shown in purple. We are looking for the point on the curve at which the temperature goes up by 2 degrees. Go to the 0 point on the vertical axis, go up to 2, and then move right until you meet the purple curve. At this point the curve intersects the vertical line, which is exactly between 2070 and 2080, that is, 2075. This means that the temperature will go up by 2 degrees in the year 2075.
- The curve corresponding to “Implement Kyoto Protocol” is dark blue. We are looking for the point on the curve at which the temperature goes up by 1 degree, so go to the point 0 on the vertical axis, go up to 1, and move right until you meet the dark blue curve. At this point, the curve intersects the vertical line corresponding to 2040, which means that in the year 2040 the temperature is predicted to go up by 1 degree Celsius.

PROBLEM 13

- If we carry on as usual, in what year will the temperature go up by 1 degree Celsius (1°C)?
- If we implement the Kyoto Protocol, in what year will the temperature go up by 2 degrees Celsius (2°C)?

Calculator Corner

Some calculators have a key that finds the additive inverse of a given number. For example, to find the opposite of 9, as in Example 6a, press **9** **[+/-]** or **9** **[CHS]** and the correct answer, -9 , will be displayed. Below are more examples from this section done with a calculator.

Example 8 $5 + (-2)$

Press **5** **+** **-** **2** **ENTER**

Example 9 $-5 + 3$

Press **-** **5** **+** **3** **ENTER**

Example 10 $-3 + (-2)$

Press **-** **3** **+** **-** **2** **ENTER**

Example 11(b) $-10 + 6$

Press **-** **1** **0** **+** **6** **ENTER**

Example 12(b) $-20 - 3$

Press **-** **2** **0** **-** **3** **ENTER**

Example 12(d) $8 - 13$

Press **8** **-** **1** **3** **ENTER**

> Exercises 9.1



> Practice Problems > Self-Tests
> Media-rich eBooks > e-Professors > Videos

< **A** > **Introduction to the Integers** The set $\{-5, -2, 0, 1, 3\}$ will be used in Problems 1–3.

- List the whole numbers in the set.
 - List the positive numbers in the set.
- List the natural numbers in the set.
 - List the negative numbers in the set.
- List the integers in the set.

Answers to PROBLEMS

13. a. 2035 b. 2080

In Problems 4–5, indicate how the integers are used in the given situation.

4.



5. The five largest U.S. cities

Rank	City	State	Population in 2003	Change since 2000
1	New York	New York	8,085,742	77,464
2	Los Angeles	California	3,819,951	125,131
3	Chicago	Illinois	2,869,121	-26,895
4	Houston	Texas	2,009,690	56,059
5	Philadelphia	Pennsylvania	1,479,339	-38,211

Source: <http://www.citymayors.com>.

In Problems 6–7, write the integer that represents the situation.

6. a. A \$100 withdrawal from your bank account.

b. A \$40 deposit to your bank account.

7. a. A \$50 million increase in the budget.

b. A \$30 million deficit in the budget.

In Problems 8–10, graph the integers on the number line, then fill in the blank with $<$ or $>$ to make the statement true.

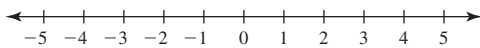
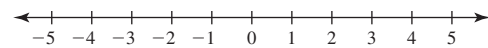
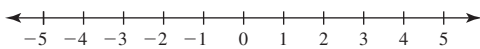
8. a. $-1, 2, 4$ b. -1 _____ 2 4 _____ 2 9. a. $-5, 0, -2$ b. -2 _____ -5 0 _____ -2 10. a. $-4, -1, 5$ b. -1 _____ -4 -1 _____ 5

< B > Additive Inverses In Problems 11–14, find the additive inverse (opposite).

11. 0

12. -11 13. -17

14. 10

< C > Absolute Value In Problems 15–20, find each value.

15. $|2|$ 16. $|21|$ 17. $|-11|$ 18. $|-15|$ 19. $|-30|$ 20. $|-16|$

< D > Addition of Integers Using a Number Line In Problems 21–30, add (verify your answer using a number line).

21. $2 + 1$ 22. $3 + 3$ 23. $-4 + 3$ 24. $-5 + 1$ 25. $5 + (-1)$ 26. $6 + (-5)$ 27. $-3 + (-3)$ 28. $-2 + (-5)$ 29. $-4 + 4$ 30. $3 + (-3)$

< E > Adding Integers Using Addition Rules In Problems 31–40, add.

31. $-3 + 5$ 32. $-18 + 21$ 33. $8 + (-1)$ 34. $19 + (-6)$ 35. $-8 + 13$ 36. $-9 + 11$ 37. $-17 + 4$ 38. $-18 + 9$ 39. $-4 + (+8) + 6 + (-2)$ 40. $-17 + (+5) + (-6) + 7$

< F > Subtracting Integers In Problems 41–50, subtract.

41. $-4 - 7$

42. $-5 - 11$

43. $-9 - 11$

44. $-4 - 16$

45. $8 - 12$

46. $7 - 13$

47. $8 - (-4)$

48. $9 - (-7)$

49. $0 - (-4) - 3 - (-3)$

50. $0 - 4 - (-5) - 5$

< G > Applications Involving Integers

51. Ocean floor depth Mount Pico in the Azores is 7615 feet above sea level. The distance from the ocean floor to the crest of Mount Pico is 23,615 feet. How many feet below sea level is the ocean floor?

53. Temperature differences The temperature in Death Valley is 53°C , and on Mount McKinley it is -20°C . What is the difference in temperature between Death Valley and Mount McKinley?

55. Temperature differences The temperature in the center core of the Earth reaches $+5000^{\circ}\text{C}$. In the thermosphere (a region in the upper atmosphere) it is $+1500^{\circ}\text{C}$. Find the difference in temperature between the center of the Earth and the thermosphere.

57. Temperature differences The record high temperature in Calgary, Alberta, is $+99^{\circ}\text{F}$. The lowest is -46°F . Find the difference between these extremes.

59. Elevator rides Joe was on the tenth floor of a building. He got on the elevator and he went three floors up, two down, five up, seven down. Representing these trips as $+3$, -2 , $+5$, and -7 , on what floor is Joe now?

52. Distance between high and low The highest point on Earth is Mount Everest, 9 kilometers above sea level. The lowest point is the Mariannas trench in the Pacific, 11 kilometers below sea level. What is the distance between these two extremes?

54. Temperature differences The temperature in the troposphere (the air layer around the Earth) is -56°C , and on Mount McKinley it is -20°C . Find the temperature difference between the troposphere and Mount McKinley.

56. Water temperature differences The water temperature of the White Sea is -2°C . In the Persian Gulf it is 36°C . Find the difference in temperature between the Persian Gulf and the White Sea.

58. Stock prices The price of a certain stock at the beginning of a week is \$42. Here are the changes in price during the week: $+1$, $+2$, -1 , -2 , -1 . What is the price of the stock at the end of the week?

60. Temperature changes Here are the temperature changes by the hour in a certain city:

1 PM $+2$

2 PM $+1$

3 PM -1

4 PM -3

If the temperature was initially 15°C , what was it at 4 PM?

Parents education and SAT scores The chart shows that the verbal scores for test takers with parents who had no high school (H.S.) diploma is -95 , that is, 95 points *below* average. (By the way, the average score in math was 514 and the average verbal score was 506.)

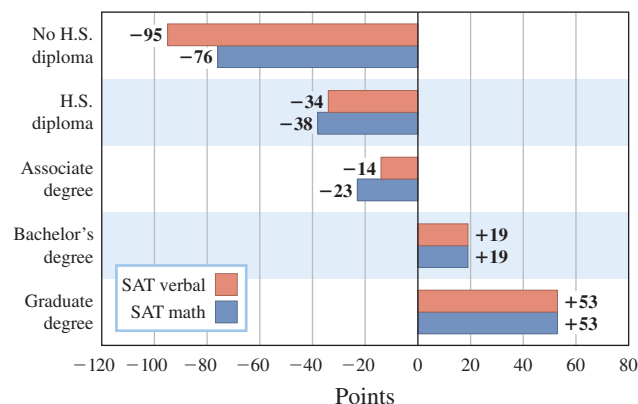

For Problems 61–68, use the chart.

61. SAT scores What integer corresponds to the verbal scores of test takers whose parents earned a bachelor's degree? What was their score?

63. SAT scores What integer corresponds to the verbal scores of test takers whose parents earned a graduate degree? What was their score?

62. SAT scores What integer corresponds to the math scores of test takers whose parents earned a bachelor's degree? What was their score?

64. SAT scores Find the difference between the integers corresponding to the verbal (-95) and math (-76) scores of test takers whose parents did not earn a high school diploma.

- 65. SAT scores** Find the difference between the integers corresponding to the verbal and math scores of test takers whose parents earned a high school diploma.
- 66. SAT scores** Find the difference between the integers corresponding to the verbal and math scores of test takers whose parents earned an associate degree.
- 67. SAT scores** Find the difference between the integers corresponding to the verbal and math scores of test takers whose parents earned a bachelor's degree.
- 68. SAT scores** Find the difference between the integers corresponding to the verbal and math scores of test takers whose parents earned a graduate degree.

>>> Applications: Green Math

Temperature changes under different conditions: It is up to us! Use the chart in Example 13 to answer Problems 69–71.

- 69.** Suppose we decide to “Stabilize Emissions.” In what year will temperatures go up by 1 degree Celsius (1°C)?
- 70.** Suppose we decide to “Reduce Emissions by 25%.” In what year will the temperatures go up by 1 degree Celsius (1°C)?
- 71.** Suppose we decide to “Reduce Emissions by 75%.” In what year will the temperatures go up by 0 degree Celsius (0°C) (no change in temperature!)?

Texting under the influence The chart will be used in Problems 72–74.

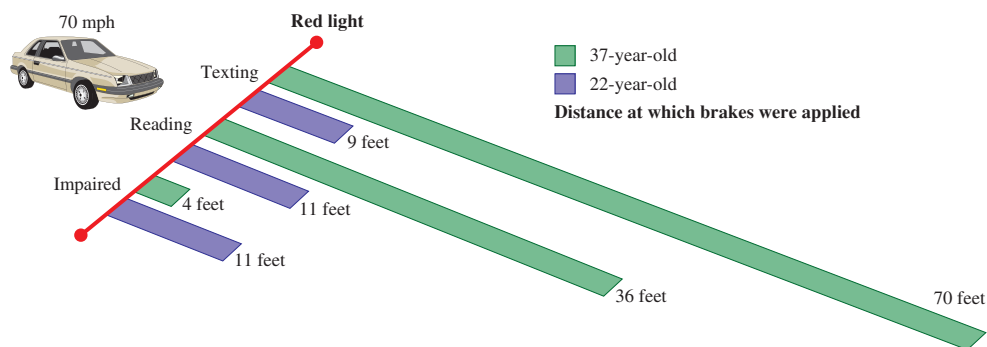

Graphic Source: Tampa Tribune, June 29, 2009.

Have you been texting and driving? According to an article in *Car and Driver*, the results may be worse than **drinking and driving under the following conditions**: A simulated red brake light lit up and drivers were supposed to hit the brakes when traveling at 70 mph. The graph shows how far they traveled before hitting the brakes when drivers were either: (a) **texting**, (b) **reading a text message**, or (c) when their **blood alcohol level was 0.08** (impaired; legally intoxicated in most states). Note that results will vary depending on many factors, like speed at which you are driving, condition of your brakes, and type of phone used.

- 72. a.** How far did the 37-year-old travel before hitting the brakes when texting?
- b.** How far did the 22-year-old travel before hitting the brakes when texting?
- c.** What was the difference in the distance at which the brakes were applied when texting?
- 73. a.** How far did the 37-year-old travel before hitting the brakes when reading a text?
- b.** How far did the 22-year-old travel before hitting the brakes when reading a text message?
- c.** What was the difference in the distance at which the brakes were applied when reading a text message?
- 74. a.** How far did the 37-year-old travel before hitting the brakes when impaired?
- b.** How far did the 22-year-old travel before hitting the brakes when impaired?
- c.** What was the difference in the distance at which the brakes were applied when impaired?

Read the article! (<http://tinyurl.com/ljqx4x>)

Budget surplus or deficits The chart will be used in Problems 75–78.

75. What was the surplus in '01 (2001)?
76. What was the last year in which there was a surplus?
77. What was the first year in which there was a deficit?
78. What was the March estimate for the projected deficit in '09 (2009)?

How Estimates of the 2009–12 Budget Surplus or Deficit Have Changed Over Time

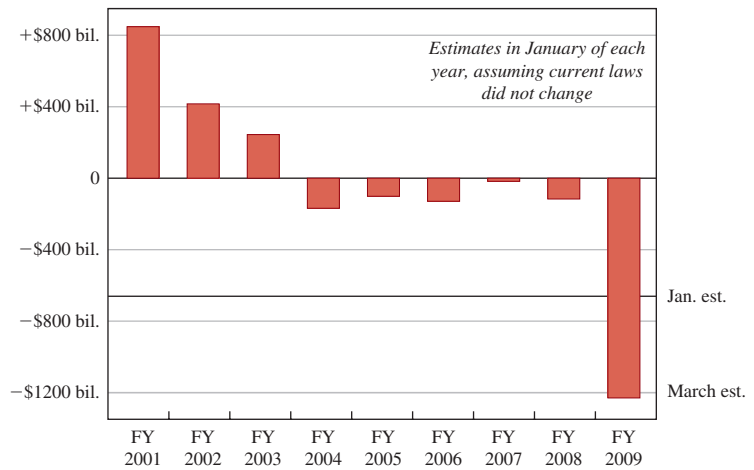

Source: <http://tinyurl.com/n8na7r> (NY Times).

>>> Using Your Knowledge

A little history The accompanying chart contains some important historical dates.

Important Historical Dates

323 B.C.	Alexander the Great dies
216 B.C.	Hannibal defeats the Romans
A.D. 476	Fall of the Roman Empire
A.D. 1492	Columbus lands in America
A.D. 1776	The Declaration of Independence signed
A.D. 1939	World War II starts
A.D. 1988	Reagan and Gorbachev hold summit

+476 (or simply 476). To find the number of years that elapsed between the fall of the Roman Empire and the defeat by Hannibal, we write

$$476 - (-216) = 476 + 216 = 692$$

↑
↑
↑

Fall of the Roman Empire (A.D. 476)
Hannibal defeats the Romans (216 B.C.)
Years elapsed

We can use negative integers to represent years B.C. For example, the year Alexander the Great died can be written as -323 , while the fall of the Roman Empire occurred in

Use the preceding ideas to find the number of years elapsed between the following time periods.

79. The fall of the Roman Empire and the death of Alexander the Great.
80. Columbus's landing in America and Hannibal's defeat of the Romans.
81. The landing in America and the signing of the Declaration of Independence.
82. The year Reagan and Gorbachev held a summit conference and the signing of the Declaration of Independence.
83. The start of World War II and the death of Alexander the Great.

>>> Write On

84. Write in your own words what you mean by the additive inverse of an integer.
85. Write in your own words why a and $-a$ are called opposites.
86. Write in your own words the procedure you use to add two integers with different signs.
87. Write in your own words the procedure you use to subtract two integers with different signs.

Concept Checker

Fill in the blank(s) with the correct word(s), phrase, or mathematical statement.

- | | | |
|--|------------------------------|---------------------------------------|
| 88. The positive integers are _____. | -1, -2, -3 | 0 |
| 89. The negative integers are _____. | right | $a = b + c$ |
| 90. The integer a is less than the integer b ($a < b$) if a lies to the _____ of b on the number line. | left | $b = a + c$ |
| 91. b is greater than a is written as _____. | 0, 1, 2, 3 | add |
| 92. The additive inverse of a is _____. | 1, 2, 3, ... | subtract |
| 93. The absolute value of a number n is its _____ from 0. | $b < a$ | distance |
| 94. $a - b = c$ means _____. | $b > a$ | difference |
| 95. To subtract an integer _____ its opposite. | $-a$ | $-1, -2, -3, \dots$ |

Mastery Test

96. Find the additive inverse of each number.
 a. 19 b. -23
97. Find the absolute value of each number.
 a. $|-8|$ b. $|4|$ c. $|0|$
98. Use the number line to add $5 + (-3)$.
-
99. Use the number line to add $-4 + 2$.
-
100. Use the number line to add $-2 + (-3)$.
-
101. Add.
 a. $-7 + (-5)$ b. $-9 + 5$
 c. $9 + (-5)$
102. Subtract.
 a. $14 - 7$ b. $-21 - 4$
 c. $-8 - (-5)$ d. $7 - 10$
103. a. Which of the three social networks had the most sessions per Monthly Unique Visitor in January 2008*? How many sessions per Monthly Unique Visitor did they have?
 b. Which of the three social networks had the most sessions per Monthly Unique Visitor in January 2009? How many sessions per month for each unique visitor did they have?
104. Consider the set of numbers $\{-3, -1, 0, 2, 6\}$
 a. List the natural numbers in the set.
 b. List the whole numbers in the set.
 c. List the positive integers in the set.
 d. List the negative integers in the set.
105. Give an **integer** that represents the following situation:
 a. The stock market gained 80 points.
 b. An investor lost \$100,000.



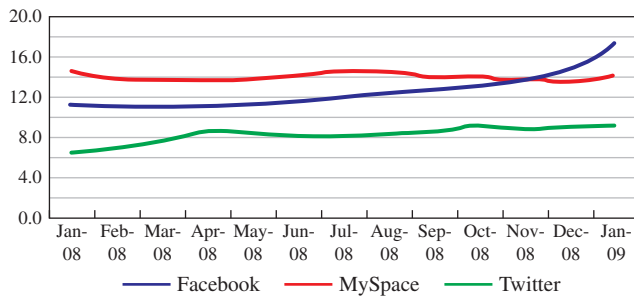

Sessions per Monthly Unique Visitor



* Monthly Unique Visitor means the number of individual visitors counted only *once* during the month. Thus, if you visit five times during a 1-month period you will be counted only once.

- 106.** Describe how the integers are being used in the given situation.

Master's Golf Tournament

NAME	SCORE
 Phil Mickelson	-7
 Tim Clark	-5
 Retief Goosen	-4
 Jose Maria Olazabal	-4
 Tiger Woods	-4

- 107.** Graph the integers -4 , 0 , -1 , and 5 .

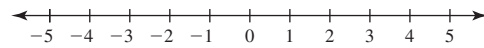

- 108.** Insert the symbol $>$ or $<$ to make the statement true.
 -4 _____ -1
- 109.** Insert the symbol $>$ or $<$ to make the statement true.
 0 _____ -4
- 110.** Insert the symbol $>$ or $<$ to make the statement true.
 0 _____ -1

>>> Skill Checker

Find:

111. 5^2

112. 3^2

113. $2^3 \cdot 3^2$

114. $5^2 \cdot 3^3$

9.2

Multiplication and Division of Integers

▶ Objectives

You should be able to:

- A** > Multiply or divide two given integers.
- B** > Raise an integer to a given power.
- C** > Multiply more than two given integers.

▶ To Succeed, Review How To . . .

1. Multiply and divide whole numbers. (pp. 50, 65)
2. Raise a whole number to a given power. (pp. 78, 83–85)

▶ Getting Started

The scientists in the cartoon have forgotten how to multiply whole numbers. Products and quotients of integers can be found in the same way as products and quotients of whole numbers. The only difference is that we have to determine if the result is positive or negative. Look at the pattern that follows and see if you can discover a rule for multiplying integers.

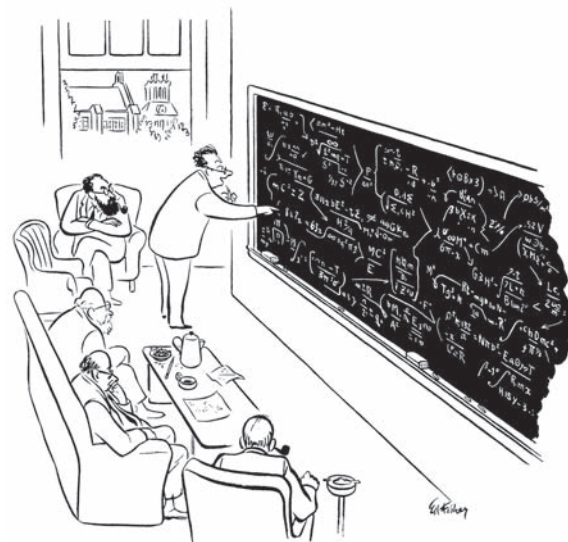

"Say, I think I see where we went off. Isn't eight times seven fifty six?"

© The New Yorker Collection 1954 Ed Fisher from cartoonbank.com. All Rights Reserved.

<p style="color: blue; font-size: small;">This number decreases by 1.</p> <p style="color: blue; font-size: small;">This number decreases by 3.</p>	<p style="color: blue; font-size: small;">This number decreases by 1.</p> <p style="color: blue; font-size: small;">This number increases by 3.</p>
$3 \cdot 3 = +9$	$3 \cdot (-3) = -9$
$2 \cdot 3 = +6$	$2 \cdot (-3) = -6$
$1 \cdot 3 = +3$	$1 \cdot (-3) = -3$
$0 \cdot 3 = 0$	$0 \cdot (-3) = 0$
$-1 \cdot 3 = -3$	$-1 \cdot (-3) = +3$
$-2 \cdot 3 = -6$	$-2 \cdot (-3) = +6$
$-3 \cdot 3 = -9$	$-3 \cdot (-3) = +9$

A > Multiplication and Division of Integers

The numbers shown in red represent the products of integers with *opposite* (*unlike*) signs; their product is *negative*. The numbers in blue have the *same* sign; their product is *positive*. Recall that 0 is neither positive nor negative.

Since the same rule applies to division (because, as you recall $a \div b = c$ means $a = b \times c$), we can summarize this discussion with the following rule:

Sign Rules for \times and \div

When Multiplying or Dividing Numbers with	The Answer Is
Same (like) signs	+
Opposite (unlike) signs	-

We can explain why the multiplication of integers with *unlike* signs is negative. Take $(3) \cdot (-4)$. Since multiplication is a process of repeated addition,

$$\begin{aligned} (3) \cdot (-4) &= (-4) + (-4) + (-4) \\ &= -12 \end{aligned}$$

For example:

$7 \cdot 8 = +56$ $-3 \cdot (-8) = +24$	$\left. \begin{array}{l} \\ \end{array} \right\}$ Same signs, answer is + .
$16 \div 2 = +8$ $-24 \div (-6) = +4$	$\left. \begin{array}{l} \\ \end{array} \right\}$ Same signs, answer is + .
$-7 \cdot 8 = -56$ $-3 \cdot 5 = -15$	$\left. \begin{array}{l} \\ \end{array} \right\}$ Opposite (unlike) signs, answer is - .
$-30 \div 6 = -5$ $27 \div (-3) = -9$	$\left. \begin{array}{l} \\ \end{array} \right\}$ Opposite (unlike) signs, answer is - .

When multiplying numbers you should remember the special case of multiplying any number by zero: The multiplication property of zero.

MULTIPLICATION PROPERTY OF ZERO

For any real number a ,

$$a \cdot 0 = 0 \cdot a = 0$$

This means that the product of any real number and 0 is 0.

EXAMPLE 1 Multiplying integers

Multiply:

- a. $9 \cdot 8$ b. $-5 \cdot 3$
 c. $-5 \cdot (-4)$ d. $7 \cdot (-6)$

SOLUTION 1

- a. $9 \cdot 8 = 72$
 b. $-5 \cdot 3 = -15$
 Unlike signs Negative answer
 c. $-5 \cdot (-4) = 20$
 Like signs Positive answer
 d. $7 \cdot (-6) = -42$
 Unlike signs Negative answer

PROBLEM 1

Multiply:

- a. $6 \cdot 7$ b. $-4 \cdot 2$
 c. $-3 \cdot (-8)$ d. $-2 \cdot (8)$

We are now ready to do division, but we should note that there are some division problems that do not have integer answers (try $\frac{17}{5}$ or $-18 \div 7$). We discuss numbers such as $\frac{17}{5}$ and $-18 \div 7$ in Section 9.3. Moreover, division by 0 is *not* defined as indicated next.

DIVISION BY ZEROFor all real numbers a ,

$$a \div 0 \quad \text{or} \quad \frac{a}{0} \text{ is not defined.}$$

Even though division by 0 is not defined, we can always divide 0 by any nonzero real number a . The result is 0, as shown next.

DIVIDENDS OF ZEROFor all real nonzero numbers a ,

$$\frac{0}{a} = 0$$

EXAMPLE 2 Dividing integers

Divide (if possible):

- a. $35 \div 7$ b. $\frac{-12}{4}$
 c. $24 \div (-12)$ d. $\frac{-10}{-5}$
 e. $\frac{0}{10}$ f. $\frac{10}{0}$

SOLUTION 2

- a. $35 \div 7 = 5$ b. $\frac{-12}{4} = -3$
 c. $24 \div (-12) = -2$ d. $\frac{-10}{-5} = 2$
 e. $\frac{0}{10} = 0$ f. $\frac{10}{0}$ is not defined

PROBLEM 2

Divide (if possible):

- a. $42 \div 6$ b. $\frac{-18}{9}$
 c. $49 \div (-7)$ d. $\frac{-15}{-3}$
 e. $\frac{0}{15}$ f. $\frac{15}{0}$

B > Integers and Exponents

As you will recall, an exponent is a number that indicates how many times a number, called the base, is used as a factor. Thus,

$$2^2 = 2 \cdot 2 = 4$$

$$2^3 = 2 \cdot 2 \cdot 2 = 8$$

Answers to PROBLEMS

1. a. 42 b. -8 c. 24 d. -16 2. a. 7 b. -2 c. -7 d. 5 e. 0 f. Not defined

What about $(-2)^2$? Using the definition of exponent, we have

$$(-2)^2 = \underbrace{(-2) \cdot (-2)}_{\text{Like signs}} = 4$$

Note that $(-2)^2 = 4$ but $-2^2 = -(2 \cdot 2) = -4$. (Remember that -2^2 means the inverse of 2^2 , that is, $-2^2 = -4$.) Thus, $-2^2 \neq (-2)^2$ (not equal). The placing of the parentheses in the expression $(-2)^2$ is very important!

EXAMPLE 3 Integers raised to a power

Evaluate:

a. $(-3)^2$

b. -3^2

SOLUTION 3

a. $(-3)^2 = (-3) \cdot (-3) = 9$

b. $-3^2 = -(3 \cdot 3) = -9$

PROBLEM 3

Evaluate:

a. $(-4)^2$

b. -4^2

EXAMPLE 4 Integers raised to a power

Evaluate:

a. $(-2)^3$

b. -2^3

SOLUTION 4

a. $(-2)^3 = (-2) \cdot (-2) \cdot (-2) = 4 \cdot (-2) = -8$

b. $-2^3 = -(2 \cdot 2 \cdot 2) = -8$

PROBLEM 4

Evaluate:

a. $(-3)^3$

b. -3^3

C > Multiplying More than Two Integers

When multiplying more than two signed numbers, we can use some examples to determine the sign of the final product.

a. $\underbrace{(-3)(2)}_{\text{two negative factors}}(-5)$
 $= -6(-5)$
 $= +30$

two negative factors
 \downarrow
 $+$ product

b. $2\underbrace{(-4)(-3)}_{\text{four negative factors}}(-1)(-2)$
 $= -8(-3)(-1)(-2)$
 $= 24(-1)(-2)$
 $= -24(-2)$
 $= +48$

four negative factors
 \downarrow
 $+$ product

c. $\underbrace{-1(4)}_{\text{three negative factors}}(-3)(-2)$
 $= -4(-3)(-2)$
 $= 12(-2)$
 $= -24$

three negative factors
 \downarrow
 $-$ product

Answers to PROBLEMS

3. a. 16 b. -16

4. a. -27 b. -27

$$\begin{aligned}
 \text{d. } & 3(-2)(-1)(-5)(-3)(-1) && \text{five negative factors} \\
 & = \underbrace{-6(-1)}(-5)(-3)(-1) && \downarrow \\
 & = \underbrace{6(-5)}(-3)(-1) && \\
 & = \underbrace{-30(-3)}(-1) && \\
 & = 90(-1) && \\
 & = -90 && \text{— product}
 \end{aligned}$$

As you can see from the pattern, the sign of the product is determined by the number of **negative** factors in the multiplication. This result is summarized next.

PROCEDURE TO MULTIPLY MORE THAN TWO SIGNED NUMBERS

First, multiply their absolute values. The sign of the final product is

1. Positive (+) if there are an *even* number of negative factors.
2. Negative (−) if there are an *odd* number of negative factors.

EXAMPLE 5 Multiplying signed numbers

Multiply:

a. $4(-7)(-1)$ b. $(-6)(-2)(-3)$ c. $(-5)(-3)(2)(-4)$

SOLUTION 5

- a. There are **two** negative factors, (-7) and (-1) , which is an *even* number of negative factors, so the final product is *positive*. Multiply the absolute value of the numbers and remember that the final product is *positive*.

$$\begin{aligned}
 4(-7)(-1) &= (+)4(7)(1) \\
 &= 28
 \end{aligned}$$

- b. There are **three** negative factors, which is an *odd* number of negative factors, so the final product is *negative*. Multiply the absolute value of the numbers and assign the final product a *negative* sign.

$$\begin{aligned}
 (-6)(-2)(-3) &= (-)(6)(2)(3) \\
 &= -36
 \end{aligned}$$

- c. We have **three** negative factors, so the final product is *negative*. Multiply the absolute value of the numbers and assign the final product a *negative* sign.

$$\begin{aligned}
 (-5)(-3)(2)(-4) &= -(5)(3)(2)(4) \\
 &= -120
 \end{aligned}$$

PROBLEM 5

Multiply:

a. $-2(-5)(-3)$
 b. $(-3)(-6)(2)$
 c. $(2)(-4)(-3)(-5)$

What can we do to help the environment? Some of the suggestions include decreasing gas emissions and planting trees. How many trees do we have to plant? Opinions vary widely, but an acre of them has been suggested. Find out more in Example 6.

Answers to PROBLEMS

5. a. -30 b. 36 c. -120

GREEN MATH

EXAMPLE 6 How much CO₂ does an acre of trees absorb?

Suppose you have a lot that is 80 ft by 540 ft (about an acre) and you plant trees every 8 feet. There will be $\frac{80}{8} = 10$ rows of $\frac{540}{8} \approx 67$ trees in each row. (See the diagram: not to scale!)

- How many trees do you have?
- If each tree absorbs 50 pounds of CO₂ (denoted by -50), how many pounds of CO₂ does the acre of trees absorb?
- If you drive 12,000 miles a year and your car makes 24 mpg, how many gallons of gas do you use a year?
- If a gallon of gas produces 20 pounds of CO₂ when burned, how many pounds of CO₂ does your car produce?

SOLUTION 6

- You have 10 rows and 67 columns or $(10)(67) = 670$ trees.
- Each tree absorbs (-50) lb of CO₂, so the whole acre absorbs $(-50)(10)(67) = -33,500$ pounds of CO₂.
- You use $\frac{12,000}{24} = 500$ gallons of gas a year.
- Your car produces $(500)(20) = 10,000$ pounds of CO₂ per year.

Note that since an acre of trees absorbs 33,500 pounds of CO₂ and each car produces +10,000 pounds of CO₂, each acre of trees absorbs the emissions of about $\frac{-33,500}{+10,000} \approx -3.3$ cars but the amount of carbon absorbed by a tree varies widely and so will the answer!

Data Source: <http://www.coloradotrees.org/benefits.htm>.

PROBLEM 6

- If your tree lot has 10 rows of 70 trees, how many trees do you have?
- How many pounds of CO₂ does the acre of trees absorb?
- If you drive 15,000 miles a year and your car makes 25 mpg, how many gallons of gas do you use a year?
- If a gallon of gas produces 20 pounds of CO₂ when burned, how many pounds of CO₂ does your car produce?

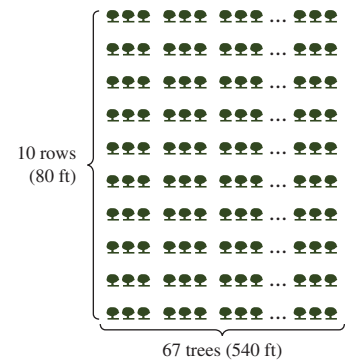

Calculator Corner

The $\boxed{+/-}$ or \boxed{CHS} key is essential when multiplying or dividing integers, as shown for Examples 1 and 2.

Example 1

- 9×8 Press $9 \times 8 \text{ ENTER}$.
- -5×3 Press $- 5 \times 3 \text{ ENTER}$.
- $-5 \times (-4)$ presents a problem. If you press $- 5 \times - 4 \text{ ENTER}$, the calculator gives -9 for an answer. To obtain the correct answer you must key in $- 5 \times 4 \boxed{+/-} \text{ ENTER}$. This time the calculator multiplies -5 by the inverse of 4, or -4 , to obtain the correct answer, 20.
- $7 \times (-6)$ Press $7 \times 6 \boxed{+/-} \text{ ENTER}$.

Example 2

- $35 \div 7$ Key in $3 5 \div 7 \text{ ENTER}$.
- $\frac{-12}{4}$ Key in $- 1 2 \div 4 \text{ ENTER}$.
- $24 \div (-12)$ presents the same problem as part c of Example 1. If you key in $2 4 \div - 1 2 \text{ ENTER}$, you do not get the correct answer. As before, the proper procedure is to key in $2 4 \div 1 2 \boxed{+/-} \text{ ENTER}$, which gives the correct answer, -2 .
- $-10 \div (-5)$ has to be done like part c. The correct entries are $- 1 0 \div 5 \boxed{+/-} \text{ ENTER}$.
- $10 \div 0$ Key in $1 0 \div 0 \text{ ENTER}$. The calculator will show ERROR.

The examples involving decimals may be done similarly.

Answers to PROBLEMS

6. a. 700 b. $-35,000$ c. 600 d. 12,000



> Practice Problems > Self-Tests
> Media-rich eBooks > e-Professors > Videos

> Exercises 9.2

< **A** > **Multiplication and Division of Integers** In Problems 1–30, multiply or divide.

- | | | |
|-----------------------|----------------------|----------------------|
| 1. $16 \cdot 2$ | 2. $9 \cdot 4$ | 3. $-7 \cdot 8$ |
| 4. $-10 \cdot 4$ | 5. $2 \cdot (-5)$ | 6. $9 \cdot (-9)$ |
| 7. $-4 \cdot (-5)$ | 8. $-6 \cdot (-3)$ | 9. $-7 \cdot (-10)$ |
| 10. $-9 \cdot (-2)$ | 11. $10 \div 2$ | 12. $\frac{14}{2}$ |
| 13. $\frac{-20}{5}$ | 14. $-50 \div 10$ | 15. $-40 \div 8$ |
| 16. $\frac{-30}{10}$ | 17. $150 \div (-15)$ | 18. $96 \div (-6)$ |
| 19. $\frac{140}{-7}$ | 20. $\frac{91}{-13}$ | 21. $-98 \div (-14)$ |
| 22. $-120 \div (-30)$ | 23. $\frac{-98}{-7}$ | 24. $\frac{-92}{-4}$ |
| 25. $\frac{0}{-10}$ | 26. $\frac{0}{-15}$ | 27. $-0 \div 8$ |
| 28. $\frac{-0}{3}$ | 29. $\frac{-8}{0}$ | 30. $-5 \div 0$ |

< **B** > **Integers and Exponents** In Problems 31–40, find the value.

- | | | | | |
|--------------|--------------|------------|--------------|------------|
| 31. $(-4)^2$ | 32. -4^2 | 33. -5^2 | 34. $(-5)^2$ | 35. -6^3 |
| 36. $(-6)^3$ | 37. $(-3)^4$ | 38. -3^4 | 39. $(-5)^3$ | 40. -5^3 |

< **C** > **Multiplying More than Two Integers** In Problems 41–50, multiply.

- | | | |
|---------------------|---------------------|---------------------|
| 41. $-3(4)(-5)$ | 42. $-5(2)(-3)$ | 43. $-4(-2)(5)$ |
| 44. $-2(-5)(9)$ | 45. $-3(-5)(-2)$ | 46. $-3(-10)(-2)$ |
| 47. $-4(-5)(2)(3)$ | 48. $-10(-3)(6)(2)$ | 49. $-2(4)(-3)(-2)$ |
| 50. $3(-2)(-1)(-5)$ | | |

> > > Applications

51. **Stockholders' losses** The net loss of a company was \$6400. If the company has 3200 stockholders and the losses are equally distributed among them, how much money did each stockholder lose?
52. **Profit or loss** A rock concert promoter sold 9000 tickets at \$5 each and 3000 tickets at \$8 each. If the performers charged \$50,000, what was the promoters' profit or loss?

Use the following tables for Problems 53–56.

1 all-beef frank: +45 calories
1 slice of bread: +65 calories

Running: -15 calories (1 minute)	Swimming: -7 calories (1 minute)
-------------------------------------	-------------------------------------

53. **Calories** If a person eats 2 beef franks and runs for 5 minutes, what is the caloric gain or loss?
54. **Calories** If the person in Problem 53 also swims for 10 minutes, what is the caloric gain or loss?
55. **Calories** If a person eats 2 beef franks in 2 slices of bread and then runs for 8 minutes, what is the caloric gain or loss?
56. **Calories** If the person of Problem 55 also swims for 15 minutes, what is the caloric gain or loss?

- 57. Money** A child opened a savings account and made four deposits of \$15 each and three withdrawals of \$10 each. How much money was in the account after these transactions?
- 58. Stock** A man bought 10 shares of a certain stock. Here are the changes in price for the stock during the following week: +1, -2, -3, +1, -2. How much money did he gain or lose on his 10 shares?
- 59. Investments** An investment increased in value by $\frac{5}{8}$. A woman had invested \$400. How much did the value of her investment increase?
- 60. Investments** An investment went down in value by $\frac{1}{8}$. A woman had invested \$1600. How much did the value of her investment decrease?

Applications: Green Math

The environmental lapse Wait, wait, don't worry: we are not forgetting the environment! The *Environmental Lapse* is the rate of decrease of temperature with altitude (elevation): the higher you are, the lower the temperature. As a matter of fact, the temperature drops about 4°F (-4°F) for each **1000** feet of altitude. *Source:* www.answers.com.

Fill in the blanks in the chart:

	Altitude in (1000 ft)	Altitude \times Rate of Change	Temperature Change
	1	$1(-4)$	-4°F
	2	$2(-4)$	-8°F
61.	5	_____	_____
62.	10	_____	_____
63.	15	_____	_____

The metric environmental lapse In the metric system, the environmental lapse is about -7°C (negative 7 degrees Celsius) for each kilometer of altitude.

Fill in the blanks in the chart:

	Altitude in kilometers	Altitude \times Rate of Change	Temperature Change
	1	$1(-7)$	-7°C
	2	$2(-7)$	-14°C
64.	3	_____	_____
65.	5	_____	_____
66.	6	_____	_____

- 67. Pikes Peak** You are at the base of Pikes Peak and the temperature is about 70°F . You climb to the top of the peak, about 14,000 feet. Give an expression that would tell you the temperature at the top. (*Hint:* Use the facts given for Problems 61–63.) What is that temperature in degrees Fahrenheit?
- 68. Mount McKinley** Mt. McKinley is about 20,000 feet high. If the temperature at the base is 70°F , what is the temperature at the top in degrees Fahrenheit?
- 69. Mount McKinley** Mt. McKinley is about 6000 meters high and the temperature at the base is 20°C . What is the temperature at the top in degrees Celsius? (*Hint:* Use the facts given for Problems 64–67.)
- 70. Mount Everest** You are at the base of Mt. Everest and the temperature is about 20°C . If you could climb to the top of Mt. Everest, an elevation of more than 8000 meters, what expression would tell you the temperature at the top? What is that temperature in degrees Celsius?

>>> Using Your Knowledge

Splitting the atom The valence (or oxidation number) of a compound is found by using the sum of the valences of each individual atom present in the compound. For example, the valence of hydrogen is +1, the valence of sulphur is +6, and that of oxygen is -2. Thus the valence of sulphuric acid is

$$\begin{aligned} & \text{H}_2\text{SO}_4 \\ & 2(\text{valence of H}) + (\text{valence of S}) + 4(\text{valence of O}) \\ & = 2(+1) + (+6) + 4(-2) \\ & = 2 + 6 + (-8) = 0 \end{aligned}$$

Use this idea to solve Problems 71–75.

- 71.** Find the valence of phosphate, PO_4 , if the valence of phosphorus (P) is +5 and that of oxygen (O) is -2.
- 72.** Find the valence of nitrate, NO_3 , if the valence of nitrogen (N) is +5 and that of oxygen (O) is -2.
- 73.** Find the valence of sodium bromate, NaBrO_3 , if the valence of sodium (Na) is +1, the valence of bromine (Br) is +5, and the valence of oxygen (O) is -2.
- 74.** Find the valence of sodium dichromate, $\text{Na}_2\text{Cr}_2\text{O}_7$, if the valence of sodium (Na) is +1, the valence of chromium (Cr) is +6, and that of oxygen (O) is -2.
- 75.** Find the valence of water, H_2O , if the valence of hydrogen (H) is +1 and that of oxygen (O) is -2.

>>> Write On

- 76.** Write in your own words why the product of two negative numbers should be positive.
- 77.** Write in your own words why the product of two integers with different signs should be negative.
- 78.** Write in your own words why division by 0 is not defined.

>>> Concept Checker

Fill in the blank(s) with the correct word(s), phrase, or mathematical statement.

- 79.** When **multiplying** or **dividing** numbers with the **same** sign the answer is _____.
- 80.** **Division** by **zero** is not _____.
- 81.** For $a \neq 0$, $\frac{0}{a} =$ _____.
- 82.** An **exponent** is a number that indicates how many times the **base** is used as a _____.
- | | | |
|--|----------------|-----------------|
| | product | a |
| | factor | negative |
| | defined | positive |
| | 0 | |

>>> Mastery Test

- 83.** Find: a. $(-10)^2$ b. -10^2
- 84.** Find: a. $(-10)^3$ b. -10^3
- 85.** Find: a. $42 \div 7$ b. $\frac{-16}{4}$
- 86.** Find: a. $4 \cdot 7$ b. $-8 \cdot 4$
- c. $36 \div (-12)$ d. $\frac{-16}{-4}$ c. $-8 \cdot (-4)$ d. $8 \cdot (-9)$
- 87.** Find: a. $(-3)(4)(-5)$ **88.** Find: a. $(2)(-5)(3)(-4)$
- b. $(-5)(-2)(-3)$ b. $(-3)(2)(-5)(-6)$

>>> Skill Checker

Perform the indicated operations.

- 89.** $\frac{3}{4} \times \frac{12}{5}$ **90.** $\frac{5}{8} \times \frac{6}{7}$ **91.** $\frac{5}{8} \div \frac{7}{16}$ **92.** $\frac{4}{9} \div \frac{11}{18}$ **93.** 0.32×8
- 94.** 0.82×9 **95.** $0.49 \div 7$ **96.** $0.54 \div 9$ **97.** $\frac{0.64}{0.8}$ **98.** $\frac{0.72}{0.09}$

9.3

The Rational Numbers

▶ Objectives

You should be able to:

- A** > Find the additive inverse of a rational number.
- B** > Find the absolute value of a rational number.
- C** > Add two rational numbers.
- D** > Subtract two rational numbers.
- E** > Multiply two rational numbers.
- F** > Divide two rational numbers.
- G** > Solve applications involving rational numbers.
- H** > Classify real numbers.

▶ To Succeed, Review How To . . .

1. Find the additive inverse and the absolute value of an integer. (pp. 554–555)
2. Perform the four fundamental operations with fractions and decimals. (pp. 135–140, 157–163)
3. Divide by a power of 10. (pp. 227–228)

▶ Getting Started

The ad for Burlington PrintWorks multipurpose paper uses whole numbers (500), mixed numbers ($8\frac{1}{2}$), and decimals (0.008/sh.). We have studied:

The natural (counting) numbers: 1, 2, 3, . . .

The whole numbers: 0, 1, 2, 3, . . .

The integers: . . . , -3, -2, -1, 0, 1, 2, 3, . . .

We are now ready to study the *rational numbers*.



Burlington
 Multipurpose Paper
 $8\frac{1}{2} \times 11''$
 500 sh.
 Price/Unit: \$0.008/sh.
 Price: \$3.99

RATIONAL NUMBERS

The **rational numbers** consist of all numbers that can be written in the form $\frac{a}{b}$, where a and b are integers and $b \neq 0$.

In symbols, $\{r \mid r = \frac{a}{b}, a \text{ and } b \text{ integers and } b \neq 0\}$

The “ \mid ” bar is read as “such that”.

Since any number of the form $\frac{a}{b}$ can be written as a decimal (by dividing a by b), the rational numbers include all the corresponding *decimals* as well. Moreover, *integers* are rational numbers, since any integer a can be written as $\frac{a}{1}$. Fortunately, everything we have said about the integers works for the rational numbers. We now discuss some properties that apply to these rational numbers.

A > Additive Inverses (Opposites)

As with the integers, every rational number has an *additive inverse (opposite)* and an *absolute value*. The table shows some rational numbers and their additive inverses.

Rational Number	Additive Inverse (Opposite)
$\frac{9}{8}$	$-\frac{9}{8}$
$-\frac{3}{4}$	$\frac{3}{4}$
5.9	-5.9
-6.8	6.8

Note that the sum (addition) of additive inverses is 0. For example, $\frac{9}{8} + \left(-\frac{9}{8}\right) = 0$ and $-6.8 + 6.8 = 0$.

EXAMPLE 1 Additive inverse of a rational number

Find the additive inverse (opposite).

- a. $\frac{5}{2}$ b. -4.8 c. $-3\frac{1}{3}$ d. 7.2

SOLUTION 1

- a. The additive inverse of $\frac{5}{2}$ is $-\frac{5}{2}$.
 b. The additive inverse of -4.8 is 4.8.
 c. The additive inverse of $-3\frac{1}{3}$ is $3\frac{1}{3}$.
 d. The additive inverse of 7.2 is -7.2.

PROBLEM 1

Find the additive inverse.

- a. $\frac{3}{4}$ b. -5.1 c. $-9\frac{1}{4}$ d. 3.9

B > Absolute Value

The absolute value of a rational number is obtained in the same way as the absolute value of an integer, as shown next.

EXAMPLE 2 Absolute value of a rational number

Find the absolute value of:

- a. $-\frac{3}{7}$ b. 2.1 c. $-2\frac{1}{2}$ d. -4.1

SOLUTION 2

- a. $\left|-\frac{3}{7}\right| = \frac{3}{7}$ b. $|2.1| = 2.1$
 c. $\left|-2\frac{1}{2}\right| = 2\frac{1}{2}$ d. $|-4.1| = 4.1$

PROBLEM 2

Find the absolute value of:

- a. $-\frac{1}{8}$ b. 3.4
 c. $-3\frac{1}{4}$ d. -8.2

Answers to PROBLEMS

1. a. $-\frac{3}{4}$ b. 5.1 c. $9\frac{1}{4}$ d. -3.9 2. a. $\frac{1}{8}$ b. 3.4 c. $3\frac{1}{4}$ d. 8.2

C > Addition of Rational Numbers

Rational numbers are added in the same way as integers. Here is the rule.

ADDING RATIONAL NUMBERS

1. If both numbers have the *same* sign, add their absolute values and give the sum the common sign.
2. If the numbers have *opposite* signs, subtract their absolute values and give the difference the sign of the number with the greater absolute value.

This is illustrated in Examples 3 and 4.

EXAMPLE 3 Adding rational numbers

Add:

- a. $-8.6 + 3.4$ b. $6.7 + (-9.8)$
 c. $-2.3 + (-4.1)$

SOLUTION 3

- a. $-8.6 + 3.4 = -(8.6 - 3.4) = -5.2$
 b. $6.7 + (-9.8) = -(9.8 - 6.7) = -3.1$
 c. $-2.3 + (-4.1) = -(2.3 + 4.1) = -6.4$

PROBLEM 3

Add:

- a. $-7.5 + 2.1$
 b. $8.3 + (-9.7)$
 c. $-1.4 + (-6.1)$

EXAMPLE 4 Adding rational numbers

Add:

- a. $-\frac{3}{7} + \frac{5}{7}$ b. $\frac{2}{5} + \left(-\frac{5}{8}\right)$

SOLUTION 4

a. $-\frac{3}{7} + \frac{5}{7} = +\left(\frac{5}{7} - \frac{3}{7}\right) = \frac{2}{7}$

b. As usual, we first find the LCD of 5 and 8, which is 40. We then write

$$\frac{2}{5} = \frac{16}{40} \quad \text{and} \quad -\frac{5}{8} = -\frac{25}{40}$$

Thus,

$$\frac{2}{5} + \left(-\frac{5}{8}\right) = \frac{16}{40} + \left(-\frac{25}{40}\right) = -\left(\frac{25}{40} - \frac{16}{40}\right) = -\frac{9}{40}$$

PROBLEM 4

Add:

- a. $-\frac{5}{9} + \frac{7}{9}$
 b. $\frac{3}{4} + \left(-\frac{5}{3}\right)$

As with the whole numbers, the addition of rational numbers is *associative* and *commutative*.

D > Subtraction of Rational Numbers

As with the integers, we define subtraction as follows:

SUBTRACTION

For any rational numbers a and b ,

$$a - b = a + (-b)$$

Remember, this means that to subtract b , we add the inverse (opposite) of b . Then use the rule for adding rational numbers.

Answers to PROBLEMS

3. a. -5.4 b. -1.4 c. -7.5
 4. a. $\frac{2}{9}$ b. $-\frac{11}{12}$

EXAMPLE 5 Subtracting rational numbers

Subtract:

a. $-4.2 - (-3.1)$

b. $-2.5 - (-7.8)$

c. $\frac{2}{9} - \left(-\frac{4}{9}\right)$

d. $-\frac{5}{6} - \frac{7}{4}$

SOLUTION 5 First, write the problem as an addition, then use the rules to add rational numbers.

a. $-4.2 - (-3.1) = -4.2 + 3.1 = -(4.2 - 3.1) = -1.1$

b. $-2.5 - (-7.8) = -2.5 + 7.8 = +(7.8 - 2.5) = 5.3$

c. $\frac{2}{9} - \left(-\frac{4}{9}\right) = \frac{2}{9} + \frac{4}{9} = \frac{6}{9} = \frac{2}{3}$

d. The LCD is 12:

$$-\frac{5}{6} = -\frac{10}{12} \quad \text{and} \quad \frac{7}{4} = \frac{21}{12}$$

$\begin{array}{c} \boxed{\times 2} \downarrow \\ \hline -\frac{5}{6} = -\frac{10}{12} \\ \hline \boxed{\times 2} \uparrow \end{array}$
 $\begin{array}{c} \boxed{\times 3} \downarrow \\ \hline \frac{7}{4} = \frac{21}{12} \\ \hline \boxed{\times 3} \uparrow \end{array}$

Thus,

$$-\frac{5}{6} - \frac{7}{4} = -\frac{5}{6} + \left(-\frac{7}{4}\right) = -\frac{10}{12} + \left(-\frac{21}{12}\right) = -\left(\frac{10}{12} + \frac{21}{12}\right) = -\frac{31}{12}$$

PROBLEM 5

Subtract:

a. $-3.8 - (-2.5)$

b. $-4.7 - (-6.9)$

c. $\frac{3}{8} - \left(-\frac{1}{8}\right)$

d. $-\frac{7}{8} - \frac{5}{6}$

E > Multiplication of Rational Numbers

The multiplication of rational numbers uses the same rules of signs as the multiplication of integers.

Sign Rules for Multiplication and Division

When Multiplying Two Rational Numbers with	The Product Is
Like (same) signs	Positive (+)
Unlike (opposite) signs	Negative (-)

EXAMPLE 6 Multiplying rational numbers

Multiply:

a. $-3.1 \cdot 4.2$

b. $-1.2 \cdot (-3.4)$

c. $-\frac{3}{4} \cdot \left(-\frac{5}{2}\right)$

d. $\frac{5}{6} \cdot \left(-\frac{4}{7}\right)$

SOLUTION 6a. -3.1 and 4.2 have *unlike* signs. The result is *negative*. Thus,

$$-3.1 \cdot 4.2 = -13.02$$

b. -1.2 and -3.4 have *like* signs. The result is *positive*. Thus,

$$-1.2 \cdot (-3.4) = 4.08$$

c. $-\frac{3}{4}$ and $-\frac{5}{2}$ have *like* signs. The result is *positive*. Thus,

$$-\frac{3}{4} \cdot \left(-\frac{5}{2}\right) = \frac{15}{8}$$

d. $\frac{5}{6}$ and $-\frac{4}{7}$ have *unlike* signs. The result is *negative*. Thus,

$$\frac{5}{6} \cdot \left(-\frac{4}{7}\right) = -\frac{20}{42} = -\frac{10}{21}$$

PROBLEM 6

Multiply:

a. $-2.2 \cdot 3.2$ b. $-1.3 \cdot (-4)$

c. $-\frac{3}{7} \cdot \left(-\frac{4}{5}\right)$ d. $\frac{6}{7} \cdot \left(-\frac{2}{3}\right)$

Note that the multiplication of rational numbers is *associative* and *commutative*.**Answers to PROBLEMS**5. a. -1.3 b. 2.2 c. $\frac{1}{2}$ d. $-\frac{41}{24}$ 6. a. -7.04 b. 5.2 c. $\frac{12}{35}$ d. $-\frac{4}{7}$

F > Reciprocals and Division of Rational Numbers

The division of rational numbers is related to the *reciprocal* of a number. As you recall, two nonzero numbers a and $\frac{1}{a}$ are *reciprocals* (or *multiplicative inverses*) and their product is 1. Here are some numbers and their reciprocals.

Number	Multiplicative Inverse (Reciprocal)	Check
$\frac{3}{4}$	$\frac{4}{3}$	$\frac{3}{4} \cdot \frac{4}{3} = 1$
$-\frac{5}{2}$	$-\frac{2}{5}$	$-\frac{5}{2} \cdot \left(-\frac{2}{5}\right) = 1$

RECIPROCAL OF A NUMBER

The reciprocal of any nonzero number $\frac{a}{b}$ is $\frac{b}{a}$ and the reciprocal of $-\frac{a}{b}$ is $-\frac{b}{a}$.

Note that $\frac{a}{b} \cdot \frac{b}{a} = 1$ and $-\frac{a}{b} \cdot \left(-\frac{b}{a}\right) = 1$.

EXAMPLE 7 Finding the reciprocal

Find the reciprocal.

a. $\frac{3}{7}$ b. $-\frac{8}{3}$

SOLUTION 7

- a. The reciprocal of $\frac{3}{7}$ is $\frac{7}{3}$ because $\frac{3}{7} \cdot \frac{7}{3} = 1$.
 b. The reciprocal of $-\frac{8}{3}$ is $-\frac{3}{8}$ because $-\frac{8}{3} \cdot \left(-\frac{3}{8}\right) = 1$.

PROBLEM 7

Find the reciprocal.

a. $\frac{4}{5}$ b. $-\frac{7}{9}$

As in Section 2.3, the idea of a reciprocal can be used in division as follows:

DIVISION OF RATIONALS

To divide $\frac{a}{b}$ by $\frac{c}{d}$, multiply $\frac{a}{b}$ by the reciprocal of $\frac{c}{d}$; that is, $\frac{a}{b} \div \frac{c}{d} = \frac{a}{b} \cdot \frac{d}{c}$, where $b, c,$ and $d \neq 0$.

EXAMPLE 8 Dividing rational numbers

Divide:

a. $\frac{2}{5} \div \left(-\frac{3}{4}\right)$ b. $-\frac{5}{6} \div \left(-\frac{7}{2}\right)$

c. $-\frac{3}{7} \div \frac{6}{7}$

SOLUTION 8

- a. $\frac{2}{5} \div \left(-\frac{3}{4}\right) = \frac{2}{5} \cdot \left(-\frac{4}{3}\right) = -\frac{8}{15}$
 b. $-\frac{5}{6} \div \left(-\frac{7}{2}\right) = -\frac{5}{6} \cdot \left(-\frac{2}{7}\right) = \frac{10}{42} = \frac{5}{21}$
 c. $-\frac{3}{7} \div \frac{6}{7} = -\frac{3}{7} \cdot \frac{7}{6} = -\frac{21}{42} = -\frac{1}{2}$

PROBLEM 8

Divide:

a. $\frac{3}{5} \div \left(-\frac{4}{7}\right)$

b. $-\frac{6}{7} \div \left(-\frac{3}{5}\right)$

c. $-\frac{4}{5} \div \frac{8}{5}$

Answers to PROBLEMS

7. a. $\frac{5}{4}$ b. $-\frac{9}{7}$ 8. a. $-\frac{21}{20}$ b. $\frac{10}{7}$ c. $-\frac{1}{2}$

If the division involves rational numbers written as decimals, the rules of signs are, of course, unchanged. Just remember that it is easier to divide by a whole number than by a decimal. Thus to find $\frac{-3.6}{1.8}$, multiply the numerator and denominator by 10 ($1.8 \times 10 = 18$, a whole number), obtaining:

$$\frac{-3.6}{1.8} = \frac{-3.6 \times 10}{1.8 \times 10} = \frac{-36}{18} = -2$$

EXAMPLE 9 Dividing rational numbers

Divide:

a. $\frac{-4.2}{2.1}$

b. $\frac{-8.1}{-16.2}$

c. $\frac{9.6}{-3.2}$

d. $\frac{-1.07}{3.21}$

SOLUTION 9

a. $\frac{-4.2}{2.1} = \frac{-4.2 \cdot 10}{2.1 \cdot 10} = \frac{-42}{21} = -2$

b. $\frac{-8.1}{-16.2} = \frac{-8.1 \cdot 10}{-16.2 \cdot 10} = \frac{-81}{-162} = \frac{1}{2}$

c. $\frac{9.6}{-3.2} = \frac{9.6 \cdot 10}{-3.2 \cdot 10} = \frac{96}{-32} = -3$

d. $\frac{-1.07}{3.21} = \frac{-1.07 \cdot 100}{3.21 \cdot 100} = \frac{-107}{321} = -\frac{1}{3}$

PROBLEM 9

Divide:

a. $\frac{-3.6}{1.2}$

b. $\frac{-3.1}{-12.4}$

c. $\frac{6.5}{-1.3}$

d. $\frac{-2.05}{8.20}$

G > Applications of Rational Numbers

Rational numbers occur in everyday life and can be used to verify claims in brochures and such. The one below claims that you can save \$3 a year (360 days) by using a CFL bulb instead of an incandescent one.

GREEN MATH**EXAMPLE 10** Saving electricity and money using CFL bulbs

- Find the cost of using a 40-watt incandescent bulb 3 hours a day for a year (360 days) if the electric rate is \$0.10 per kWh (kilowatt hour).
- Find the cost of using an 11-watt CFL bulb 3 hours a day for a year if the electric rate is \$0.10 per kWh (1000 watts/hour).
- What are the annual savings of a CFL over an incandescent?
- What are the *energy* savings of an 11-watt CFL bulb over a 40-watt incandescent for the 10,000-hour life of the CFL bulb?

CFL Energy Savings			
Incandescent Light Bulb	Compact Fluorescent		
	CFL	CFL Annual Savings*	Energy Savings of CFL (over 10,000 hour life)
40 watt	11 watt	\$3	\$29
60 watt	13 watt	\$5	\$47
75 watt	19 watt	\$6	\$56
100 watt	25 watt	\$8	\$75

*Based on bulb use of three hours per day and \$0.10 per kWh electric rate.

Source: <http://www.pemc.org/pdfs/CFL%20Brochure.pdf>.

PROBLEM 10

- Find the cost of using a 60-watt incandescent bulb 3 hours a day for a year (360 days) if the electric rate is \$0.10 per kWh (kilowatt hour).
- Find the cost of using a 13-watt CFL bulb 3 hours a day for a year if the electric rate is \$0.10 per kWh (1000 watts/hour).
- What are the annual savings of a CFL over an incandescent?
- What are the *energy* savings of a 13-watt CFL bulb over a 60-watt incandescent for the 10,000 hour life of the CFL bulb?

Note: To find the cost of the watts used for a year (360 days), use the formula:

$$\frac{(\text{watts})(\text{hours})(\text{days})(\text{rate})}{1000}$$

Answers to PROBLEMS

9. a. -3 b. $\frac{1}{4}$ c. -5 d. $-\frac{1}{4}$ 10. a. \$6.48 b. \$1.40 c. \$5.08 d. \$47

SOLUTION 10

- a. To find the cost of using a 40-W incandescent we find the number of watts used by multiplying (40) by the hours used (3), times the number of days (360) and then multiplying the result by \$0.10

$$\text{obtaining } [(40) \cdot (3) \cdot (360)] \cdot (\$0.10) = [(120)(360)] \cdot (0.10)$$

$$\begin{aligned} \text{and then dividing by 1000 to get kilowatts} &= \frac{[(120)(360)] \cdot (0.10)}{1000} \\ &= \frac{12 \cdot 36 \cdot 0.1}{10} \\ &= \frac{43.2}{10} \\ &= \$4.32 \end{aligned}$$

Thus, it costs \$4.32 to use the incandescent bulb.

- b. To find the cost of using the CFL we proceed similarly except that we use 11 W instead of 40, obtaining

$$\begin{aligned} &[(11) \cdot (3) \cdot (360)] \cdot (\$0.10) \\ &= \frac{[(33)(360)] \cdot (0.10)}{1000} \\ &= \frac{33 \cdot 36 \cdot 0.1}{100} \\ &= \frac{118.8}{100} \\ &= \$1.19 \end{aligned}$$

Thus, it costs \$1.19 to use the CFL bulb.

- c. The annual savings are $\$4.32 - \$1.19 = \$3.13$ (close to the claim of \$3 CFL annual savings in the brochure).
- d. The computations here are actually easier since we are finding the energy savings over the 10,000 lifetime hours of the bulb (instead of 3 hours for 360 days). The cost for the incandescent is:

$$\begin{aligned} &\frac{40 \cdot 10,000 \cdot 0.10}{1000} \\ &= 400 \cdot 0.10 \\ &= \$40.00 \end{aligned}$$

$$\begin{aligned} \text{For the CFL (use 11 instead of 40)} &\frac{11 \cdot 10,000 \cdot 0.10}{1000} \\ &= 110 \cdot 0.10 \\ &= \$11.00 \end{aligned}$$

Thus, the savings over the 10,000 hour life are $\$40 - \$11 = \$29$, which is exactly what the brochure predicts.

H > Classifying Real Numbers

Rational numbers have two very important properties:

1. They can be expressed as a fraction or ratio (rational) of the form $\frac{a}{b}$, where a and b are integers and $b \neq 0$.
2. When the numerator a is divided by the denominator b , the rational number $\frac{a}{b}$ becomes a terminating or a repeating decimal.

For example, $\frac{1}{2} = 0.5$ and $\frac{2}{5} = 0.4$ are terminating decimals, but $\frac{1}{3} = 0.\overline{3}$ and $\frac{1}{6} = 0.1\overline{6}$ are repeating decimals.

It can be shown that only decimals that terminate or repeat can be written in the form $\frac{a}{b}$. A decimal number that is not a rational number is nonterminating and nonrepeating. It is an **irrational** number.

IRRATIONAL NUMBERS

An **irrational number** cannot be written in the form $\frac{a}{b}$ and will never terminate or repeat when written as a decimal.

Here are some irrational numbers:

$$\begin{aligned} &0.12345\dots \\ &0.101001000\dots \\ \sqrt{2} &= 1.414213562\dots \\ \pi &= 3.141592653\dots \end{aligned}$$

What about $\sqrt{9}$? Here you must remember that $\sqrt{9} = 3$, which is a natural number (not irrational). Before classifying real numbers, let us look at the relationship among numbers we have studied.

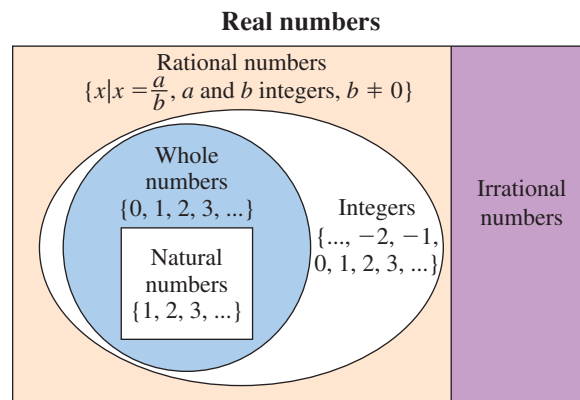

Note that, in particular, the real numbers are composed of all the rational and all the irrational numbers. To see the relationship among these numbers, see Problems 69 to 72.

For now, note that:

All natural numbers are whole numbers.

Example: 3 is a natural number *and* a whole number.

All whole numbers are integers.

Example: 0 and 5 are whole numbers so 0 and 5 are integers.

All integers are rational numbers.

Example: -3 and 5 are integers so -3 and 5 are rational numbers.

All rational numbers are real numbers.

Example: $-\frac{5}{6}$ and 0.3 are rational numbers, so $-\frac{5}{6}$ and 0.3 are real numbers.

All irrational numbers are real numbers.

Example: $\sqrt{2}$ is an irrational number, so $\sqrt{2}$ is a real number.

EXAMPLE 11 Classifying numbers

Classify each number by making a check mark in the appropriate row.

	a.	b.	c.	d.	e.	f.	g.	h.
	5.7	$-\frac{7}{9}$	0	$\sqrt{8}$	3	$\sqrt{25}$	$0.\overline{66}$	$-1\frac{1}{4}$
Natural number					✓	✓		
Whole number			✓		✓	✓		
Integer			✓		✓	✓		
Rational number	✓	✓	✓		✓	✓	✓	✓
Irrational number				✓				
Real number	✓	✓	✓	✓	✓	✓	✓	✓

SOLUTION 11

- a. 5.7 is a terminating decimal, so it is rational and real.
- b. $-\frac{7}{9}$ is of the form $\frac{a}{b}$, so it is rational and real.
- c. 0 is a whole number and thus an integer, a rational, and real number.
- d. $\sqrt{8}$ is nonterminating and nonrepeating, so it is irrational and real.
- e. 3 is a natural number and thus a whole number, an integer, a rational number, and a real number.
- f. Do not be fooled! $\sqrt{25} = 5$, so it is a natural number, a whole number, an integer, a rational number, and a real number.
- g. $0.\overline{66}$ is a repeating decimal, so it is rational and real.
- h. $-1\frac{1}{4}$ can be written as $-\frac{5}{4}$, so it is rational and real.

PROBLEM 11

Classify each number by making a check mark in the appropriate row.

	a.	b.	c.	d.	e.	f.	g.	h.
	$-\frac{2}{7}$	3.4	8	$\sqrt{81}$	$-2\frac{3}{4}$	$\sqrt{2}$	$0.\overline{36}$	0
N								
W								
I								
Rat.								
Irr.								
Real								

Exercises 9.3



- > Practice Problems
- > Self-Tests
- > Media-rich eBooks
- > e-Professors
- > Videos

< A > Additive Inverses (Opposites) In Problems 1–6, find the additive inverse (opposite).

- 1. $\frac{7}{3}$
- 2. $-\frac{8}{9}$
- 3. -6.4
- 4. -2.3
- 5. $3\frac{1}{7}$
- 6. $4\frac{1}{8}$

< B > Absolute Value In Problems 7–12, find each value.

- 7. $|\frac{-4}{5}|$
- 8. $|\frac{-9}{2}|$
- 9. $|-3.4|$
- 10. $|-2.1|$
- 11. $|1\frac{1}{2}|$
- 12. $|\frac{3}{4}|$

Answers to PROBLEMS

11.

	a.	b.	c.	d.	e.	f.	g.	h.
	$-\frac{2}{7}$	3.4	8	$\sqrt{81}$	$-2\frac{3}{4}$	$\sqrt{2}$	$0.\overline{36}$	0
N			✓	✓				
W			✓	✓				✓
I			✓	✓				✓
Rat.	✓	✓	✓	✓	✓		✓	✓
Irr.						✓		
Real	✓	✓	✓	✓	✓	✓	✓	✓

< C > Addition of Rational Numbers In Problems 13–30, find each value.

13. $-7.8 + 3.1$

14. $-6.7 + 2.5$

15. $3.2 + (-8.6)$

16. $4.1 + (-7.9)$

17. $-3.4 + (-5.2)$

18. $-7.1 + (-2.6)$

19. $-\frac{2}{7} + \frac{5}{7}$

20. $-\frac{5}{11} + \frac{7}{11}$

21. $-\frac{3}{4} + \frac{1}{4}$

22. $-\frac{5}{6} + \frac{1}{6}$

23. $\frac{3}{4} + \left(-\frac{5}{6}\right)$

24. $\frac{5}{6} + \left(-\frac{7}{8}\right)$

25. $-\frac{1}{6} + \frac{3}{4}$

26. $-\frac{1}{8} + \frac{7}{6}$

27. $-\frac{1}{3} + \left(-\frac{2}{7}\right)$

28. $-\frac{4}{7} + \left(-\frac{3}{8}\right)$

29. $-\frac{5}{6} + \left(-\frac{8}{9}\right)$

30. $-\frac{4}{5} + \left(-\frac{7}{8}\right)$

< D > Subtraction of Rational Numbers In Problems 31–40, find each value.

31. $-3.8 - (-1.2)$

32. $-6.7 - (-4.3)$

33. $-3.5 - (-8.7)$

34. $-6.5 - (-9.9)$

35. $4.5 - 8.2$

36. $3.7 - 7.9$

37. $\frac{3}{7} - \left(-\frac{1}{7}\right)$

38. $\frac{5}{6} - \left(-\frac{1}{6}\right)$

39. $-\frac{5}{4} - \frac{7}{6}$

40. $-\frac{2}{3} - \frac{3}{4}$

< E > Multiplication of Rational Numbers In Problems 41–50, find each value.

41. $-2.2 \cdot 3.3$

42. $-1.4 \cdot 3.1$

43. $-1.3 \cdot (-2.2)$

44. $-1.5 \cdot (-1.1)$

45. $\frac{5}{6} \cdot \left(-\frac{5}{7}\right)$

46. $\frac{3}{8} \cdot \left(-\frac{5}{7}\right)$

47. $-\frac{3}{5} \cdot \left(-\frac{5}{12}\right)$

48. $-\frac{4}{7} \cdot \left(-\frac{21}{8}\right)$

49. $-\frac{6}{7} \cdot \frac{35}{8}$

50. $-\frac{7}{5} \cdot \frac{15}{28}$

< F > Reciprocals and Division of Rational Numbers In Problems 51–55, find each value.

51. a. $\frac{3}{5} \div \left(-\frac{4}{7}\right)$

51. b. $\frac{4}{9} \div \left(-\frac{1}{7}\right)$

52. a. $-\frac{2}{3} \div \left(-\frac{7}{6}\right)$

52. b. $-\frac{5}{6} \div \left(-\frac{25}{18}\right)$

53. a. $-\frac{5}{8} \div \frac{7}{8}$

53. b. $-\frac{4}{5} \div \frac{8}{15}$

54. a. $\frac{-3.1}{6.2}$

54. b. $\frac{1.2}{-4.8}$

55. a. $\frac{-1.6}{-9.6}$

55. b. $\frac{-9.8}{-1.4}$

>>> Applications: Green Math
< G > Solving Applications Involving Rational Numbers

Saving money and energy The table in Example 10 will be used in Problems 56–60.

56. Find the cost of using a 75-watt incandescent bulb 3 hours a day for a year if the electric rate is \$0.10 per kWh (kilowatt hour).

57. Find the cost of using a 19-watt CFL bulb three hours a day for a year if the electric rate is \$0.10 per kWh (1000 watts/hour).

58. Referring to Problems 56 and 57, find the annual savings of a 19-watt CFL bulb over a 75-watt incandescent.

59. What are the *energy* savings of a 19-watt CFL bulb over a 75-watt incandescent for the 10,000-hour life of the CFL bulb?

60. What are the *energy* savings of a 25-watt CFL bulb over a 100-watt incandescent for the 10,000-hour life of the CFL bulb?

< H > Classifying Real Numbers In Problems 61–68, classify each number by making a check mark in the appropriate row.

	61.	62.	63.	64.	65.	66.	67.	68.
	$\sqrt{16}$	$-1\frac{7}{9}$	0	9.2	3	$\sqrt{11}$	0.68	$-1\frac{3}{4}$
Natural number								
Whole number								
Integer								
Rational number								
Irrational number								
Real number								

Sets and numbers The natural numbers (N), the whole numbers (W), the integers (I), and the rational numbers (Q) can be symbolized using set notation.

$$N = \{1, 2, 3, \dots\}$$

$$W = \{0, 1, 2, \dots\}$$

$$I = \{\dots, -2, -1, 0, 1, 2, \dots\}$$

$$Q = \{r \mid r = \frac{a}{b}, \text{ where } a \text{ and } b \text{ are integers and } b \neq 0\}$$

Moreover, if all of the elements of set A are also members of set B , we say that A is contained in B (or A is a proper subset of B) and write $A \subset B$.

In Problems 69–72, fill in the blank with the \subset symbol and write the meaning where indicated.

69. $N \subset W$ means that every _____ is also a _____.

70. $W \subset I$ means that every _____ is also an _____.

71. $I \subset Q$ means that every _____ is also a _____.

72. $N \subset W \subset I \subset Q$

>>> Using Your Knowledge

Moods Have you met anybody nice today, or did you have an unpleasant experience? Perhaps the person you met was *very nice* or your experience was *very unpleasant*. Psychologists and linguists have a numerical way to indicate the difference between nice and very nice or between unpleasant and very unpleasant. Suppose you assign a positive number (+2, for example) to the adjective *nice*, and a negative number (say, -2) to *unpleasant*, and a positive number greater than 1 (say +1.75) to *very*. Then, very nice means

$$(1.75) \cdot (2) = 3.50 \quad (1.75)(2) \text{ are multiplied.}$$

and very unpleasant means

$$(1.75) \cdot (-2) = -3.50$$

Here are some adverbs and adjectives and their numerical values.

Adverbs		Adjectives	
Slightly	0.54	Wicked	-2.5
Rather	0.84	Disgusting	-2.1
Decidedly	0.16	Average	-0.8
Very	1.75	Good	3.1
Extremely	1.45	Lovable	2.4

Find the value of each mood.

73. Slightly wicked
74. Decidedly average
75. Extremely disgusting
76. Rather lovable
77. Very good

By the way, if you got all the answers correct, you are 4.495!

>>> Write On

78. Write in your own words why $-a^2$ is always negative ($a \neq 0$).
79. Write in your own words why $(-a)^2$ is always positive ($a \neq 0$).
80. Why do you think that $\frac{a}{0}$ is not defined?

>>> Concept Checker

Fill in the blank(s) with the correct word(s), phrase, or mathematical statement.

81. The **additive inverse** (opposite) of a is _____.
82. By the definition of subtraction, $a - b =$ _____ when a and b are rational numbers.
83. When **multiplying** two rational numbers with **like** (same) signs the **product** is _____.
84. When **multiplying** two rational numbers with **unlike** (opposite) signs the **product** is _____.
85. The **reciprocal** of $\frac{a}{b}$ is _____ ($b \neq 0$).
86. The **reciprocal** of $-\frac{a}{b}$ is _____ ($b \neq 0$).

$\frac{b}{a}, a \neq 0$	$\frac{a}{b}, a \neq 0$
$\frac{1}{a}$	negative
$-a$	0
$-\frac{b}{a}, a \neq 0$	$-\frac{a}{b}, b \neq 0$
positive	$a + (-b)$

>>> Mastery Test

87. Find the additive inverse of $\frac{13}{10}$.
88. Find the additive inverse of -4.7 .
89. Find the additive inverse of $-1\frac{1}{5}$.
90. Find the additive inverse of 5.6.
91. Find: $\left|-\frac{6}{17}\right|$
92. Find: $|5.9|$
93. Find: $\left|-7\frac{9}{11}\right|$
94. Find: $|-3.5|$
95. Add: $-4.6 + 4.3$
96. Add: $5.5 + (-2.8)$
97. Add: $-1.1 + (-2.4)$
98. Add: $-\frac{5}{11} + \frac{10}{11}$
99. Add: $\frac{1}{5} + \left(-\frac{1}{6}\right)$
100. Subtract: $-5.3 - (-2.3)$
101. Subtract: $-7.8 - 1.7$
102. Subtract: $\frac{5}{11} - \left(-\frac{6}{11}\right)$
103. Subtract: $-\frac{1}{8} - \frac{1}{6}$
104. Multiply: $-1.4 \cdot 6.3$
105. Multiply: $-2.4 \cdot (-2.6)$
106. Multiply: $-\frac{3}{8} \cdot \frac{5}{9}$
107. Multiply: $\frac{5}{4} \cdot \left(-\frac{2}{5}\right)$
108. Find the reciprocal of $-\frac{1}{3}$.
109. Divide: $\frac{3}{5} \div \frac{7}{15}$
110. Divide: $-\frac{7}{8} \div \left(-\frac{5}{24}\right)$
111. Divide: $-\frac{8}{7} \div \frac{4}{7}$
112. Divide: $\frac{-6.4}{1.6}$
113. Divide: $\frac{-1.5}{-6}$
114. Divide: $\frac{3.6}{-1.2}$

115. Classify the given numbers.

	a.	b.	c.	d.
	3.2	$-\frac{8}{9}$	9	$\sqrt{21}$
Natural number				
Whole number				
Integer				
Rational number				
Irrational number				
Real number				

116. Classify the given numbers.

	a.	b.	c.	d.
	0	$\sqrt{49}$	0. $\overline{34}$	$-2\frac{1}{4}$
Natural number				
Whole number				
Integer				
Rational number				
Irrational number				
Real number				

>>> Skill Checker

In Problems 117–120, perform the indicated operations.

117. $7 \cdot 9 - 5$

118. $36 \div 3 \cdot 2$

119. $6 \div 3 - (3 - 5)$

120. $8 \div 4 \cdot 2 + 2 \cdot (3 - 5)$

9.4

Order of Operations

▶ Objectives

You should be able to:

A > Evaluate expressions using the order of operations.

B > Evaluate expressions using fraction bars as grouping symbols.

▶ To Succeed, Review How To . . .

1. Add, subtract, multiply, and divide rational numbers. (pp. 577–580)
2. Use the order of operations for fractions. (pp. 83–85, 247–248)

▶ Getting Started

Do you know your handicap in bowling? No, it is not the fact that your ball goes in the gutter all the time! In bowling, “Handicapping is a means of placing bowlers and teams with varying degrees of skill on as equitable a basis as possible for their competition against each other” (*source*: Bowl.com). This handicap is defined as *180 minus your average, multiplied by 9/10*. Suppose your average is 130, what is your handicap? Is it

$$180 - 130 \cdot \frac{9}{10}?$$

or

$$(180 - 130) \cdot \frac{9}{10}?$$

Note that

$$180 - 130 \cdot \frac{9}{10} = 180 - 13 \cdot 9 = 180 - 117 = 63$$

but

$$(180 - 130) \cdot \frac{9}{10} = 50 \cdot \frac{9}{10} = 45$$

To make the meaning precise, we should use **parentheses** to indicate that your average, 130, must be subtracted from 180 first, so your handicap is 45.



A > Using the Order of Operations

Here is the order of operations for real numbers.

ORDER OF OPERATIONS (PEMDAS)

1. Do all calculations inside *parentheses* and other grouping symbols (), [], { } **first**.
2. Evaluate all *exponential* expressions.
3. Do *multiplications* and *divisions* in order from left to right.
4. Do *additions* and *subtractions* in order from left to right.

P
E
M
D
A
S

Remember PEMDAS so you can do the operations in the correct order!

Before going to the examples, let us explain what each of the lines mean.

1. Do all calculations inside *parentheses* and other grouping symbols (), [], { } **first**.

This means that when evaluating $\left\{ \left(5 + \frac{1}{2} \right) + \left[1 - \frac{1}{2} \right] \right\}$

you follow steps 1, 2, and 3

$$\textcircled{1} \left(5 + \frac{1}{2} \right) = \left(5\frac{1}{2} \right) \qquad = \left\{ \left(5\frac{1}{2} \right) + \left[1 - \frac{1}{2} \right] \right\}$$

Add inside parentheses

$$\textcircled{2} \left[1 - \frac{1}{2} \right] = \left[\frac{1}{2} \right] \qquad = \left\{ \left(5\frac{1}{2} \right) + \left[\frac{1}{2} \right] \right\}$$

Subtract inside brackets

$$\textcircled{3} \left(5\frac{1}{2} \right) + \left[\frac{1}{2} \right] = 6 \qquad = \left\{ \qquad 6 \qquad \right\}$$

Add inside braces

2. Evaluate all *exponential* expressions.

This step is easy to follow, just look for the exponents! When you see 2^3 or 4^2 , evaluate it: $2^3 = 2 \cdot 2 \cdot 2 = 8$ and $4^2 = 4 \cdot 4 = 16$

3. Do *multiplications* and *divisions* **in order** from left to right.

The key words are **in order**. Of course, you must proceed from left to right.

Thus, if you have $12 \div 4 \cdot 2$, go from left to right and do the division $12 \div 4$ **first**.

$$\begin{aligned} & 12 \div 4 \cdot 2 \\ = & \quad 3 \cdot 2 && \text{Divide } 12 \div 4 = 3 \text{ first} \\ = & \quad 6 && \text{Multiply } 3 \cdot 2 = 6 \text{ next} \end{aligned}$$

However, if you have $12 \cdot 2 \div 4$, multiply $12 \cdot 2 = 24$ then divide by 4, like this:

$$\begin{aligned} & 12 \cdot 2 \div 4 \\ & 24 \div 4 && \text{Multiply } 12 \cdot 2 = 24 \\ & 6 && \text{Divide } 24 \div 4 = 6 \end{aligned}$$

4. Do *additions* and *subtractions* in order from left to right.

Again, go in order from left to right.

$$\begin{aligned} & 3 - 4 + 5 \\ = & \quad -1 + 5 && \text{Subtract 4 from 3 first} \\ = & \quad 4 && \text{Do the addition } -1 + 5 = 4 \text{ next} \end{aligned}$$

Similarly,

$$\begin{aligned} & 3 + 4 - 5 \\ & 7 - 5 && \text{Do the addition } 3 + 4 = 7 \text{ first} \\ & 2 && \text{Then subtract 5 from 7} \end{aligned}$$

EXAMPLE 1 Evaluating expressions

Find the value of:

a. $-\frac{8}{9} \cdot 9 - 3$

b. $-27 + \frac{3}{5} \cdot 5$

SOLUTION 1

a. $-\frac{8}{9} \cdot 9 - 3$

$= -8 - 3$

M, D: Do multiplications and divisions in order from left to right ($-\frac{8}{9} \cdot 9 = -8$).

$= -11$

A, S: Then do additions and subtractions in order from left to right ($-8 - 3 = -11$).

b. $-27 + \frac{3}{5} \cdot 5$

$= -27 + 3$

M, D: Do multiplications and divisions in order from left to right ($\frac{3}{5} \cdot 5 = 3$).

$= -24$

A, S: Then do additions and subtractions in order from left to right ($-27 + 3 = -24$).**PROBLEM 1**

Find the value of:

a. $-\frac{5}{7} \cdot 7 - 3$

b. $-20 + \frac{4}{9} \cdot 9$

EXAMPLE 2 Evaluating expressions

Find the value of:

a. $-6 \div 2 \cdot 5$

b. $-6 \cdot 2 \div \frac{4}{7}$

SOLUTION 2

a. $-6 \div 2 \cdot 5$

$= -3 \cdot 5$

D: Do multiplications and divisions in **order** from left to right. ($-6 \div 2 = -3$, the division occurred first, so it was done first.)

$= -15$

M: Next, do the multiplication ($-3 \cdot 5 = -15$).

b. $-6 \cdot 2 \div \frac{4}{7}$

$= -12 \div \frac{4}{7}$

M: Do multiplications and divisions in **order** from left to right. ($-6 \cdot 2 = -12$, the multiplication occurred first, so it was done first.)

$= -12 \cdot \frac{7}{4}$

To divide by $\frac{4}{7}$: multiply by the reciprocal $\frac{7}{4}$.

$= -\cancel{12}^3 \cdot \frac{7}{4}$

Simplify by dividing -12 by 4 .

$= -21$

M: Do multiplications and divisions in **order** from left to right ($-3 \cdot 7 = -21$).**PROBLEM 2**

Find the value of:

a. $-8 \div 2 \cdot 5$

b. $-8 \cdot 2 \div \frac{4}{7}$

EXAMPLE 3 Evaluating expressionsFind the value of $8 \div (-2) \cdot \frac{5}{4} - 3 + \frac{1}{2}$.**SOLUTION 3**

$8 \div (-2) \cdot \frac{5}{4} - 3 + \frac{1}{2}$

$= -4 \cdot \frac{5}{4} - 3 + \frac{1}{2}$

M, D: Do multiplications and divisions in **order** from left to right ($8 \div (-2) = -4$).

$= -5 - 3 + \frac{1}{2}$

M, D: Do multiplications and divisions in **order** from left to right ($-4 \cdot \frac{5}{4} = -5$).

$= -8 + \frac{1}{2}$

A, S: Do the additions and subtractions in order from left to right ($-5 - 3 = -8$).

$= -7\frac{1}{2}$

A, S: Do the additions and subtractions in order from left to right ($-8 + \frac{1}{2} = -7\frac{1}{2}$).**PROBLEM 3**

Find the value of

$16 \div (-2) \cdot \frac{5}{4} - 7 + \frac{1}{2}$

Answers to PROBLEMS

1. a. -8 b. -16 2. a. -20 b. -28 3. $-16\frac{1}{2}$

EXAMPLE 4 Expressions with grouping symbols and exponents

Find the value of:

a. $-63 \div \frac{7}{9} - (2 + 3)$

b. $-8 \div 2^3 + 3 - 1$

SOLUTION 4

$$\begin{aligned} \text{a.} \quad & -63 \div \frac{7}{9} - (2 + 3) \\ & = -63 \div \frac{7}{9} - 5 \\ & = -81 - 5 \\ & = -86 \end{aligned}$$

P: First do the operation inside the parentheses ($2 + 3 = 5$).**D:** Do the division ($-63 \div \frac{7}{9} = -63 \cdot \frac{9}{7} = -81$).**S:** Then do the subtraction ($-81 - 5 = -86$).

$$\begin{aligned} \text{b.} \quad & -8 \div 2^3 + 3 - 1 \\ & = -8 \div 8 + 3 - 1 \\ & = -1 + 3 - 1 \\ & = 2 - 1 \\ & = 1 \end{aligned}$$

E: First do the exponentiation ($2^3 = 8$).**D:** Next do the division ($-8 \div 8 = -1$).**A, S:** Then do the additions and subtractions in order from left to right ($-1 + 3 = 2$).**S:** Do the final subtraction.**PROBLEM 4**

Find the value of:

a. $-64 \div \frac{8}{3} - (4 + 1)$

b. $-27 \div 3^3 + 5 - 2$

EXAMPLE 5 Expressions with grouping symbolsFind the value of $-8 \div 4 \cdot 2 + 3(5 - 2) - 3 \cdot \frac{2}{3}$.**SOLUTION 5**

$$\begin{aligned} & -8 \div 4 \cdot 2 + 3(5 - 2) - 3 \cdot \frac{2}{3} \\ = & \underbrace{-8 \div 4} \cdot 2 + 3(3) - 3 \cdot \frac{2}{3} \\ = & \underbrace{-2 \cdot 2} + 3(3) - 3 \cdot \frac{2}{3} \\ = & -4 + \underbrace{3(3)} - 3 \cdot \frac{2}{3} \\ = & -4 + 9 - \underbrace{3 \cdot \frac{2}{3}} \\ = & \underbrace{-4 + 9} - 2 \\ = & \underbrace{5} - 2 \\ = & 3 \end{aligned}$$

P: First do the operations inside the parentheses.
M, D: Now do the multiplications and divisions, in order from left to right:**D:** This means do $-8 \div 4 = -2$ first.**M:** Then do $-2 \cdot 2 = -4$.**M:** Next do $3(3) = 9$.**M:** And finally, do $-3 \cdot \frac{2}{3} = -2$.**A:** We are through with multiplications and divisions. Now do the addition of -4 and 9 .**S:** The final operation is a subtraction, $5 - 2 = 3$.**PROBLEM 5**

Find the value of

$-6 \div 3 \cdot 4 + 4(7 - 5) - 5 \cdot \frac{4}{5}$

EXAMPLE 6 Expressions with grouping symbols and exponentsFind the value of $-8 \div 4 \cdot 5 - 3(5 - 2)^2 + 5 \cdot 3\frac{1}{5}$.**SOLUTION 6**

$$\begin{aligned} & -8 \div 4 \cdot 5 - 3(5 - 2)^2 + 5 \cdot 3\frac{1}{5} \\ = & -8 \div 4 \cdot 5 - 3(3)^2 + 5 \cdot 3\frac{1}{5} \\ = & -8 \div 4 \cdot 5 - 3(9) + 5 \cdot 3\frac{1}{5} \\ = & -2 \cdot 5 - 3(9) + 5 \cdot 3\frac{1}{5} \\ = & -10 - 27 + 16 \\ = & -21 \end{aligned}$$

P: $[(5 - 2) = (3)]$ **E:** $(3^2 = 9)$ **D:** $(-8 \div 4 = -2)$ **M:** $(-2 \cdot 5 = -10, -3(9) = -27, 5 \cdot 3\frac{1}{5} = 16)$ **S, A:** $(-10 - 27 = -37, -37 + 16 = -21)$ **PROBLEM 6**

Find the value of:

$9 \div 3 \cdot 2 - 3(4 - 1)^2 + 5 \cdot 2\frac{1}{5}$

Answers to PROBLEMS

4. a. -29 b. 2

5. -4

6. -10

B > Using Fraction Bars as Grouping Symbols

Fraction bars are sometimes used as grouping symbols to indicate an expression representing a single number. To find the value of such expressions, simplify above and below the fraction bars following the order of operations. Thus,

$$\begin{aligned} & \frac{-2(3 + 8) + 4}{2(4) - 10} \\ &= \frac{-2(11) + 4}{2(4) - 10} \\ &= \frac{-22 + 4}{8 - 10} \\ &= \frac{-18}{-2} \\ &= 9 \end{aligned}$$

P, A: Add inside the parentheses in the numerator ($3 + 8 = 11$).

M: Multiply in the numerator [$-2(11) = -22$] and in the denominator [$2(4) = 8$].

A, S: Add in the numerator ($-22 + 4 = -18$), subtract in the denominator ($8 - 10 = -2$).

D: Do the final division. (Remember to use the rules of signs.)

EXAMPLE 7 Using the fraction bar as a grouping symbol

Find the value of $-5^2 + \frac{3(4 - 8)}{2} + 10 \div 5$.

SOLUTION 7

As usual, we use the order of operations.

$$\begin{aligned} &= -5^2 + \frac{3(4 - 8)}{2} + 10 \div 5 \\ &= -5^2 + \frac{3(-4)}{2} + 10 \div 5 \\ &= -25 + \frac{3(-4)}{2} + 10 \div 5 \\ &= -25 + \frac{-12}{2} + 10 \div 5 \\ &= -25 + (-6) + 10 \div 5 \\ &= -25 + (-6) + 2 \\ &= \frac{-31}{-29} + 2 \\ &= \end{aligned}$$

Given.

P: Subtract inside the parentheses ($4 - 8 = -4$).

E: Do the exponentiation ($5^2 = 25$, so $-5^2 = -25$).

M: Multiply above the division bar [$3(-4) = -12$].

D: Divide ($\frac{-12}{2} = -6$).

D: Divide ($10 \div 5 = 2$).

A: Add [$-25 + (-6) = -31$].

Do the final addition.

PROBLEM 7

Find the value of:

$$-6^2 + \frac{2(6 - 2)}{2} + 15 \div 3$$

GREEN MATH

EXAMPLE 8 Offsetting your automobile carbon emissions

You can “offset” the carbon emissions from your car by planting trees (or let somebody else do it for you for a fee). How many trees? If you travel **12,000** miles a year, your car makes **30** miles per gallon, produces **20** pounds of CO_2 per mile traveled, and each tree absorbs **50** pounds of CO_2 each year, then the number of trees you need to plant is:

$$\frac{\frac{12,000}{30} \cdot 20}{50}$$

Use the order of operations to simplify this expression.

PROBLEM 8

How many trees do you have to plant if you drive 15,000 miles a year, and your car makes 20 miles per gallon?

(continued)

Answers to PROBLEMS

7. -27 8. 300

SOLUTION 8 We simplify the terms above the fraction bar using the order of operations and proceeding from left to right, so we do the division $\frac{12,000}{30}$ first!

$$\begin{aligned} & \frac{\frac{12,000}{30} \cdot 20}{50} && \text{Given} \\ & = \frac{400 \cdot 20}{50} && \text{D: (Divide } \frac{12,000}{30} = 400) \\ & = \frac{8000}{50} && \text{M: (Multiply } 400 \cdot 20 = 8000) \\ & = 160 && \text{Do the final division } \frac{8000}{50} = 160 \end{aligned}$$

Here are two carbon calculators giving the price for offsetting different carbon emissions: <http://tinyurl.com/3x5tv1>, <http://tinyurl.com/ljjohd>.

Results may be different due to different assumptions.



Calculator Corner

Most calculators contain a set of parentheses on the keyboard. These keys will allow you to specify the exact order in which you wish operations to be performed. Thus to find the value of $(4 \cdot 5) + 6$, key in

(4 × 5) + 6 ENTER

to obtain 26. Similarly, if you key in

4 × (5 + 6) ENTER

you obtain 44. However, in many calculators you won't be able to find the answer to the problem $4(5 + 6)$ unless you key in the multiplication sign × between the 4 and the parentheses.

It's important to note that some calculators follow the order of operations automatically and others do not. To find out whether yours does, enter 2 + 3 × 4 ENTER. If your calculator follows the order of operations, you should get 14 for an answer.

> Exercises 9.4



> Practice Problems > Self-Tests
> Media-rich eBooks > e-Professors > Videos

< **A** > **Using the Order of Operations** In Problems 1–20, find the value of the expression.

- | | | |
|---|--|---|
| 1. $\frac{-4}{5} \cdot 5 + 6$ | 2. $\frac{-3}{4} \cdot 4 + 6$ | 3. $-7 + \frac{3}{2} \cdot 2$ |
| 4. $-6 + \frac{9}{2} \cdot 2$ | 5. $\frac{-7}{4} \cdot 8 - 3$ | 6. $\frac{-3}{4} \cdot 8 - 9$ |
| 7. $20 - \frac{3}{5} \cdot 5$ | 8. $30 - \frac{6}{5} \cdot 5$ | 9. $48 \div \frac{3}{4} - (3 + 2)$ |
| 10. $81 \div \frac{9}{2} - (4 + 5)$ | 11. $3 \cdot 4 \div \frac{2}{3} + (6 - 2)$ | 12. $3 \cdot 6 \div \frac{2}{3} + (5 - 2)$ |
| 13. $-36 \div 3^2 + 4 - 1$ | 14. $-16 \div 2^3 + 3 - 2$ | 15. $-8 \div 2^3 - 3 + 5$ |
| 16. $-9 \div 3^2 - 8 + 5$ | 17. $-10 \div 5 \cdot 2 + 8 \cdot (6 - 4) - 3 \cdot 4$ | 18. $-15 \div 3 \cdot 3 + 2 \cdot (5 - 2) + 8 \div 4$ |
| 19. $-4 \cdot 8 \div 2 - 3(4 - 1) + 9 \div 3$ | 20. $-6 \cdot 3 \div 3 - 2(3 - 2) - 8 \div 2$ | |

< B > Using Fraction Bars as Grouping Symbols In Problems 21–34, find the value of the expression.

21. $\frac{4 \cdot (6 - 2)}{-8} - \frac{6}{-2}$

22. $\frac{5 \cdot (6 - 2)}{-4} - \frac{16}{-4}$

23. $-5^2 + \frac{2 - 10}{4} + 12 \div 4$

24. $-4^2 + \frac{3 - 7}{2} + 18 \div 9$

25. $-3^3 + 4 - 6 \cdot 8 \div 4 - \frac{8 - 2}{-3}$

26. $-2^3 + 6 - 6 \div 3 \cdot 2 - \frac{9 - 3}{-6}$

27. $4 \cdot 9 \div 3 \cdot 10^3 - 2 \cdot (6 + 4)^2$

28. $5 \cdot 8 \div 4 \cdot (7 + 3)^3 - 2 \cdot (9 + 1)^2$

29. $(4 - 6)^2 \div 4 - \frac{2(7 - 9)}{4} - 4 \cdot 3 \div 2^2$

30. $(5 - 10)^2 \div 5 \cdot 2 - \frac{4(8 - 10)}{2} - 6 \cdot 4 \div 2^3$

31. $-7^2 + \frac{3(8 - 4)}{4} + 10 \div 2 \cdot 3$

32. $-5^2 + \frac{6(3 - 7)}{4} + 9 \div 3 \cdot 2$

33. $(-6)^2 \cdot 4 \div 4 - \frac{3(7 - 9)}{2} - 4 \cdot 3 \div 2^2$

34. $(-4)^2 \cdot 3 \div 8 - \frac{4(6 - 10)}{2} - 3 \cdot 8 \div 2^3$

>>> Applications

35. Octane rating Have you noticed the octane rating of gasoline at the gas pump? This octane rating is given by

$$\frac{R + M}{2}$$

where R is a number measuring the performance of gasoline using the Research Method and M is a number measuring the performance of gasoline using the Motor Method. If a certain gasoline has $R = 92$ and $M = 82$, what is its octane rating?

36. Octane rating If a gasoline has $R = 97$ and $M = 89$, what is its octane rating (see Problem 35)?

>>> Applications: Green Math

Planting trees to offset car carbon emissions In Problems 37 and 38, follow the procedure of Example 8 to find the number of trees needed to offset the carbon emissions produced under the given conditions.

	Miles Driven	MPG	CO ₂ per Gallon	CO ₂ Absorbed by One Tree
37.	10,000	25	20 pounds	50 pounds per year
38.	15,000	30	20 pounds	50 pounds per year

Pizza Remember the measurement chapter: length, area, and capacity? What units of measurement would you use to buy pizza? Square units, of course!

The illustration shows the price of four popular pizza sizes: 10-inch, 12-inch, 14-inch, and 16-inch. For convenience, we round prices to \$8, \$10, \$12.50, and \$15, use $\pi \approx 3.14$, and round the final answers (in cents) to one decimal place.

THIN CRUST PIZZA (Non Veg Momose)				
	10" Small	12" Medium	14" Large	16" E-Large
CHEESE with	\$7.85	\$9.95	\$12.45	\$14.95

39. a. What is the area of the 10-inch pizza?

b. What is the price per square inch for the 10-inch pizza?

41. a. What is the area of the 14-inch pizza?

b. What is the price per square inch for the 14-inch pizza?

40. a. What is the area of the 12-inch pizza?

b. What is the price per square inch for the 12-inch pizza?

42. a. What is the area of the 16-inch pizza?

b. What is the price per square inch for the 16-inch pizza?

Using Your Knowledge

43. Insert any operation signs (parentheses, +, −, ⋅, or ÷) so that the string of numbers equals the given answer.

$$3 \ 2 \ 5 \ 6 = 19$$

44. Repeat the procedure of Problem 43 for the numbers

$$9 \ 5 \ 6 \ 7 = 14$$

45. Have you heard of Einstein's problem? The idea is to use the digits 1, 2, 3, 4, 5, 6, 7, 8, 9 and any combination of the operation signs (+, −, ⋅, ÷) to write an expression that equals 100. Oh, yes, the numbers have to be in consecutive order from left to right!

Write On

46. Write in your own words why you think the order of operations is needed. Give examples.
47. When evaluating an expression, do you *always* have to do multiplications before divisions? Give examples to support your answer.
48. When evaluating expressions, do you *always* have to do additions before subtractions? Give examples to support your answer.
49. Write in your own words why the parentheses are needed when evaluating $2 + (3 \cdot 4)$ or $(2 \cdot 3) + 4$.

Concept Checker

Fill in the blank(s) with the correct word(s), phrase, or mathematical statement.

In Problems 50–55, we will refer to the abbreviation **PEMDAS**.

50. The **P** in PEMDAS means _____.
51. The **E** in PEMDAS means _____.
52. The **M** in PEMDAS means _____.
53. The **D** in PEMDAS means _____.
54. The **A** in PEMDAS means _____.
55. The **S** in PEMDAS means _____.

exponent	parentheses
multiplication	subtraction
simplify	addition
division	exclude

Mastery Test

Find the value of each expression.

56. $63 \div 9 - (2 + 5)$

57. $-64 \div 8 - (4 - 2)^2$

58. $-16 + 2^3 + 3 - 9$

59. $\frac{-3}{4} \cdot 4 - 18$

60. $-18 + \frac{4}{5} \cdot 5$

61. $-12 \div 4 \cdot 2 + 2(5 - 3) - \frac{3}{4} \cdot 4$

62. $-6^2 + \frac{4(6 - 12)}{3} + 8 \div 2$

63. The ideal heart rate while exercising for a person A years old is $[(205 - A) \cdot 7] \div 10$. What is the ideal heart rate for a 35-year-old person?

64. $4 \div (-2) \cdot \frac{3}{2} + (3 - 1)^2 + \frac{1}{2}$

Skill Checker

In Problems 65–68, multiply two different ways: first by using the distributive property, then by adding inside the parentheses before multiplying.

65. $5(7 + 2)$

66. $2(4 + 3)$

67. $3(4 + 6)$

68. $8(4 + 5)$

Collaborative Learning

Form two or more groups.

- Let each group select **three** integers from 0 to 9 and make a three digit number using the three integers, then subtract its *reversal* (the *reversal* of 856 is 658). Then, if the difference is *positive*, add its reversal. If the difference is *negative*, subtract its reversal. Here are three possibilities for three numbers.

$$\begin{array}{r} 856 \\ - 658 \\ \hline 198 \\ + 891 \\ \hline \end{array} \quad \begin{array}{r} 159 \\ - 951 \\ \hline -792 \\ - 297 \\ \hline \end{array} \quad \begin{array}{r} 872 \\ - 278 \\ \hline 594 \\ + 495 \\ \hline \end{array}$$

What answer did your group get? Did all groups get the same answer? Why do you think this works?

- Look at these patterns.

$$99 + 100 + 101 + 102 + 103 = 505$$

$$99^2 + 100^2 + 101^2 + 102^2 + 103^2 = 51,015$$

The answers 505 and 51,015 are *palindromic* numbers. Do not get alarmed; it only means that 505 and 51,015 read the same from left to right as from right to left. Will the pattern continue if six numbers are used instead of five? Let the members of your group decide.

- Look at the next patterns.

$$10,099 + 10,100 + 10,101 + 10,102 + 10,103 = 50,505$$

$$10,099^2 + 10,100^2 + 10,101^2 + 10,102^2 + 10,103^2 = 510,151,015$$

Will the pattern continue if six numbers are used instead of five? Let the members of your group decide. ▣

Research Questions

- In previous chapters we have used the customary symbols to denote the operations of addition, subtraction, multiplication, and division. Who invented the +, −, ×, and ÷ symbols, and in what publications did they first appear? *Note:* Answers may not be unique; try <http://www.roma.unisa.edu.au/07305/symbols.htm#Plus> for starters.
- Write a report about Johan Widmann's *Mercantile Arithmetic* (1489), indicating which symbols of operation were found in the book for the first time and the manner in which they were used.
- We have also used the horizontal bar to denote fractions. Who invented the horizontal bar to write common fractions, and who was the first European mathematician to use it?
- We have also used the diagonal fraction bar to write fractions as a/b . Who were the first users of the diagonal fraction bar? From what did the diagonal bar evolve?

Summary Chapter 9

Section	Item	Meaning	Example
9.1A	Positive integers Negative integers Integers	1, 2, 3, and so on -1, -2, -3, and so on ..., -2, -1, 0, 1, 2, ...	19 and 28 are positive integers. -41 and -56 are negative integers.
9.1B	Additive inverse	The additive inverse of a is $-a$.	-7 and 7 are additive inverses.
9.1C	Absolute value	The distance of a number from 0	$ -7 = 7$ and $ 4 = 4$
9.1E	Adding integers	If both integers have the <i>same</i> sign, add their absolute values and give the sum the common sign. If the integers have <i>opposite</i> signs, subtract their absolute values and give the difference the sign of the number with the larger absolute value.	$-2 + (-7)$ $= -(2 + 7)$ $= -9$ $-7 + 2 = -(7 - 2)$ $= -5$
9.1F	Subtracting integers	To subtract one integer from another, add the opposite of the number to be subtracted.	$3 - 9 = 3 + (-9)$ $= -6$
9.2A	Multiplication and division of integers	The product or quotient of integers with <i>like</i> signs is $+$ and with <i>unlike</i> signs is $-$.	$-2 \cdot (-7) = 14$ $-24 \div (-4) = 6$ $-2 \cdot 7 = -14$ $24 \div (-4) = -6$
9.3	Rational numbers	Numbers that can be written in the form $\frac{a}{b}$, where a and b are integers and $b \neq 0$	$\frac{3}{4}$, $-5\frac{1}{2}$, $-\frac{7}{8}$, 0.23, and $0.\overline{6}$ are rational.
9.3A	Additive inverse	The additive inverse of a is $-a$.	The additive inverse of $\frac{3}{4}$ is $-\frac{3}{4}$ and the additive inverse of -0.53 is 0.53.
9.3B	Absolute value	The distance of a number from 0	$ \frac{3}{4} = \frac{3}{4}$ and $ -0.7 = 0.7$
9.3F	Reciprocal Division	The reciprocal of any nonzero number $\frac{a}{b}$ is $\frac{b}{a}$. $\frac{a}{b} \div \frac{c}{d} = \frac{a}{b} \cdot \frac{d}{c}$	$\frac{2}{3}$ and $\frac{3}{2}$ are reciprocals. $\frac{3}{4} \div (-\frac{1}{2}) = \frac{3}{4} \cdot (-\frac{2}{1}) = -\frac{3}{2}$
9.3H	Irrational numbers	Numbers that cannot be written in the form $\frac{a}{b}$, where a and b are integers and $b \neq 0$. When written as decimals, irrationals are nonrepeating and nonterminating.	$\sqrt{2}$ and $\sqrt{5}$ are irrational numbers. 32.01234... and 0.101001000... are irrational (nonrepeating, nonterminating).
9.4	Order of operations (PEMDAS)	1. Do all calculations inside <i>parentheses</i> and other grouping symbols $()$, $[]$, $\{ \}$ first . 2. Evaluate all <i>exponential</i> expressions. 3. Do <i>multiplications</i> and <i>divisions</i> in order from left to right. 4. Do <i>additions</i> and <i>subtractions</i> in order from left to right.	

Review Exercises Chapter 9

(If you need help with these exercises, look in the section indicated in brackets.)

1. **9.1A** Consider the set $\{-6, -4, -1, 0, 2, 5\}$.

- a. List the negative numbers in the set.
- b. List the positive numbers in the set.
- c. List the whole numbers in the set.
- d. List the natural (counting) numbers in the set.
- e. List the integers in the set.

2. **9.1A** Indicate how the integers are used in each situation.

a. Financial markets

Symbol	Price	Change
AMEX	1866	+7
Nasdaq	2121	-1
Dow	10989	-30
NYSE	7924	+4

b. Outdoor thermometer

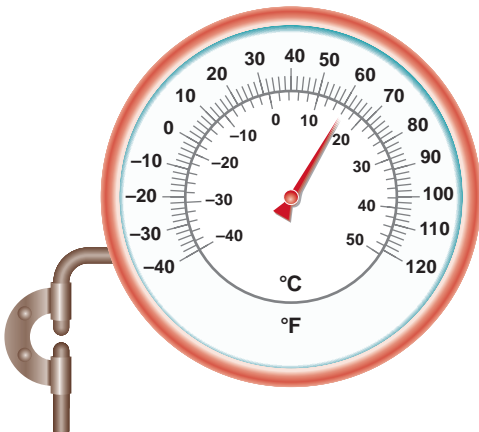

c. North America

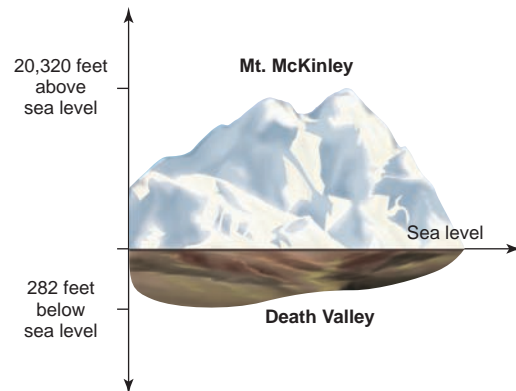

d. New Orleans elevations

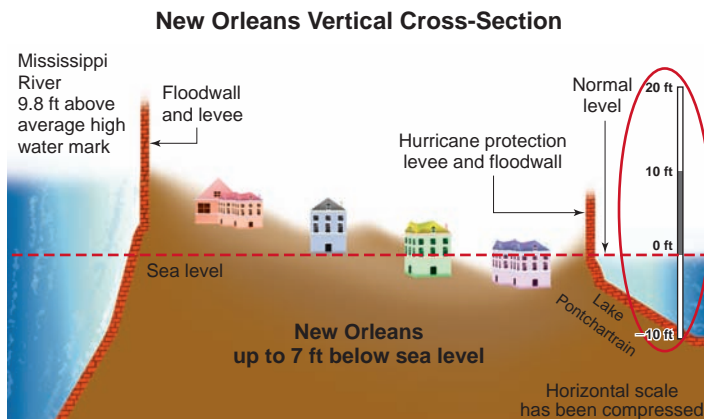

e. Population changes

2000–2050 Population Change (millions)	
Poland	-12
Portugal	-18
Romania	-24
Russia	-29
Saudi Arabia	152

3. **<9.1A>** Write the integer that represents the situation.

- The highest recorded temperature in Israel, 129°F
- The lowest recorded temperature in Canada, -63°C
- A \$53 withdrawal from your bank account
- An \$8 trillion deficit in the budget
- Submarine Kaiko descent to the lowest part of the Marianas Trench, 10,897 meters below the ocean surface.

4. **<9.1A>** Graph the given integers on the number line.

a. $-3, 0, 4$

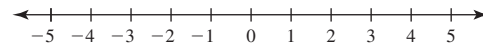

b. $-4, -2, 5$

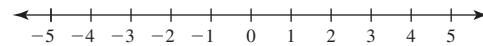

c. $-5, 0, 2$

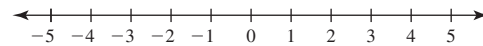

d. $-4, -3, -1$

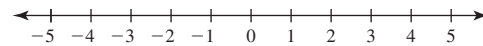

e. $0, 3, 5$

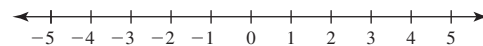

5. **<9.1A>** Fill in the blank with $<$ or $>$ to make the statement true.

- -5 _____ -1
- -1 _____ -3
- -4 _____ -2
- 1 _____ 5
- 0 _____ -2

6. **<9.1B>** Find the additive inverse (opposite).

- 10
- 11
- 12
- 13
- 14

7. **<9.1B>** Find the additive inverse (opposite).

- -9
- -8
- -7
- -6
- -5

8. **<9.1C>** Find each value.

- $|-7|$
- $|8|$
- $|-9|$
- $|10|$
- $|-11|$

9. **<9.1E>** Add.

- $-8 + (-5)$
- $-8 + (-4)$
- $-8 + (-3)$
- $-8 + (-2)$
- $-8 + (-1)$

10. **<9.1E>** Add.

- $-12 + 5$
- $-12 + 6$
- $-12 + 7$
- $-12 + 8$
- $-12 + 9$

11. **<9.1E>** Add.

- $14 + (-4)$
- $14 + (-5)$
- $14 + (-6)$
- $14 + (-7)$
- $14 + (-8)$

12. **<9.1F>** Subtract.

- $-15 - 3$
- $-15 - 4$
- $-15 - 5$
- $-15 - 6$
- $-15 - 7$

13. **<9.1F>** Subtract.

- $-10 - (-2)$
- $-10 - (-3)$
- $-10 - (-1)$
- $-10 - (-4)$
- $-10 - (-5)$

14. **<9.1F>** Subtract.

- $9 - 14$
- $9 - 15$
- $9 - 16$
- $9 - 17$
- $9 - 18$

15. **<9.2A>** Multiply.

- $-6 \cdot 4$
- $-6 \cdot 5$
- $-6 \cdot 6$
- $-6 \cdot 7$
- $-6 \cdot 8$

16. < 9.2A > Multiply.

- a. $-8 \cdot (-5)$
- b. $-8 \cdot (-6)$
- c. $-8 \cdot (-7)$
- d. $-8 \cdot (-8)$
- e. $-8 \cdot (-9)$

19. < 9.2A > Divide.

- a. $72 \div (-12)$
- b. $72 \div (-18)$
- c. $72 \div (-24)$
- d. $72 \div (-36)$
- e. $72 \div (-72)$

22. < 9.2B > Find each value.

- a. $-4^2 =$ _____
- b. $-5^2 =$ _____
- c. $-6^2 =$ _____
- d. $-7^2 =$ _____
- e. $-8^2 =$ _____

25. < 9.3A > Find the additive inverse.

- a. $-3\frac{1}{2}$
- b. $-4\frac{1}{2}$
- c. $-5\frac{1}{2}$
- d. $-6\frac{1}{2}$
- e. $-7\frac{1}{2}$

28. < 9.3B > Find each value.

- a. $|-5.1|$
- b. $|6.2|$
- c. $|-7.3|$
- d. $|8.4|$
- e. $|-9.5|$

17. < 9.2A > Multiply.

- a. $5 \cdot (-5)$
- b. $6 \cdot (-5)$
- c. $7 \cdot (-5)$
- d. $8 \cdot (-5)$
- e. $9 \cdot (-5)$

20. < 9.2A > Divide.

- a. $\frac{-15}{-5}$
- b. $\frac{-25}{-5}$
- c. $\frac{-35}{-5}$
- d. $\frac{-45}{-5}$
- e. $\frac{-55}{-5}$

23. < 9.3A > Find the additive inverse.

- a. $\frac{3}{11}$
- b. $\frac{4}{11}$
- c. $\frac{5}{11}$
- d. $\frac{6}{11}$
- e. $\frac{7}{11}$

26. < 9.3B > Find each value.

- a. $\left|-\frac{2}{11}\right|$
- b. $\left|-\frac{3}{11}\right|$
- c. $\left|-\frac{4}{11}\right|$
- d. $\left|\frac{5}{11}\right|$
- e. $\left|\frac{6}{11}\right|$

29. < 9.3C > Add.

- a. $-8.7 + 3.1$
- b. $-8.7 + 3.2$
- c. $-8.7 + 3.3$
- d. $-8.7 + 3.4$
- e. $-8.7 + 3.5$

18. < 9.2A > Divide.

- a. $\frac{-58}{2}$
- b. $\frac{-48}{2}$
- c. $\frac{-38}{2}$
- d. $\frac{-28}{2}$
- e. $\frac{-18}{2}$

21. < 9.2B > Find each value.

- a. $(-4)^2 =$ _____
- b. $(-5)^2 =$ _____
- c. $(-6)^2 =$ _____
- d. $(-7)^2 =$ _____
- e. $(-8)^2 =$ _____

24. < 9.3A > Find the additive inverse.

- a. -3.4
- b. -4.5
- c. -5.6
- d. -6.7
- e. -7.8

27. < 9.3B > Find each value.

- a. $\left|-3\frac{1}{4}\right|$
- b. $\left|4\frac{1}{4}\right|$
- c. $\left|5\frac{1}{4}\right|$
- d. $\left|-6\frac{1}{4}\right|$
- e. $\left|-7\frac{1}{4}\right|$

30. < 9.3C > Add.

- a. $6.2 + (-9.3)$
- b. $6.2 + (-9.4)$
- c. $6.2 + (-9.5)$
- d. $6.2 + (-9.6)$
- e. $6.2 + (-9.7)$

31. <9.3C> Add.

- a. $-2.1 + (-3.2)$
 b. $-2.1 + (-3.3)$
 c. $-2.1 + (-3.4)$
 d. $-2.1 + (-3.5)$
 e. $-2.1 + (-3.6)$

34. <9.3D> Subtract.

- a. $-5.9 - (-3.1)$
 b. $-5.9 - (-3.2)$
 c. $-5.9 - (-3.3)$
 d. $-5.9 - (-3.4)$
 e. $-5.9 - (-3.5)$

37. <9.3D> Subtract.

- a. $-\frac{5}{6} - \frac{4}{3}$
 b. $-\frac{5}{6} - \frac{5}{3}$
 c. $-\frac{5}{6} - \frac{7}{3}$
 d. $-\frac{5}{6} - \frac{8}{3}$
 e. $-\frac{5}{6} - \frac{2}{3}$

40. <9.3E> Multiply.

- a. $-\frac{2}{3} \cdot \left(-\frac{2}{3}\right)$
 b. $-\frac{2}{3} \cdot \left(-\frac{4}{3}\right)$
 c. $-\frac{2}{3} \cdot \left(-\frac{5}{3}\right)$
 d. $-\frac{2}{3} \cdot \left(-\frac{7}{3}\right)$
 e. $-\frac{2}{3} \cdot \left(-\frac{8}{3}\right)$

43. <9.3F> Divide.

- a. $\frac{1}{5} \div \left(-\frac{1}{7}\right)$
 b. $\frac{1}{5} \div \left(-\frac{2}{7}\right)$
 c. $\frac{1}{5} \div \left(-\frac{3}{7}\right)$
 d. $\frac{1}{5} \div \left(-\frac{4}{7}\right)$
 e. $\frac{1}{5} \div \left(-\frac{5}{7}\right)$

32. <9.3C> Add.

- a. $-\frac{3}{11} + \frac{5}{11}$
 b. $-\frac{3}{11} + \frac{6}{11}$
 c. $-\frac{3}{11} + \frac{7}{11}$
 d. $-\frac{3}{11} + \frac{8}{11}$
 e. $-\frac{3}{11} + \frac{9}{11}$

35. <9.3D> Subtract.

- a. $-3.2 - (-7.5)$
 b. $-3.2 - (-7.6)$
 c. $-3.2 - (-7.7)$
 d. $-3.2 - (-7.8)$
 e. $-3.2 - (-7.9)$

38. <9.3E> Multiply.

- a. $-3.1 \cdot 4.2$
 b. $-3.1 \cdot 4.3$
 c. $-3.1 \cdot 4.4$
 d. $-3.1 \cdot 4.5$
 e. $-3.1 \cdot 4.6$

41. <9.3E> Multiply.

- a. $\frac{5}{2} \cdot \left(-\frac{2}{7}\right)$
 b. $\frac{5}{2} \cdot \left(-\frac{3}{7}\right)$
 c. $\frac{5}{2} \cdot \left(-\frac{4}{7}\right)$
 d. $\frac{5}{2} \cdot \left(-\frac{6}{7}\right)$
 e. $\frac{5}{2} \cdot \left(-\frac{8}{7}\right)$

44. <9.3F> Divide.

- a. $-\frac{5}{2} \div \left(-\frac{1}{4}\right)$
 b. $-\frac{5}{2} \div \left(-\frac{1}{6}\right)$
 c. $-\frac{5}{2} \div \left(-\frac{1}{8}\right)$
 d. $-\frac{5}{2} \div \left(-\frac{1}{10}\right)$
 e. $-\frac{5}{2} \div \left(-\frac{1}{12}\right)$

33. <9.3C> Add.

- a. $\frac{1}{5} + \left(-\frac{2}{9}\right)$
 b. $\frac{1}{5} + \left(-\frac{4}{9}\right)$
 c. $\frac{1}{5} + \left(-\frac{5}{9}\right)$
 d. $\frac{1}{5} + \left(-\frac{7}{9}\right)$
 e. $\frac{1}{5} + \left(-\frac{8}{9}\right)$

36. <9.3D> Subtract.

- a. $\frac{2}{11} - \left(-\frac{3}{11}\right)$
 b. $\frac{2}{11} - \left(-\frac{4}{11}\right)$
 c. $\frac{2}{11} - \left(-\frac{5}{11}\right)$
 d. $\frac{2}{11} - \left(-\frac{6}{11}\right)$
 e. $\frac{2}{11} - \left(-\frac{7}{11}\right)$

39. <9.3E> Multiply.

- a. $-3.1 \cdot (-2.1)$
 b. $-3.1 \cdot (-2.2)$
 c. $-3.1 \cdot (-2.3)$
 d. $-3.1 \cdot (-2.4)$
 e. $-3.1 \cdot (-2.5)$

42. <9.3F> Find the reciprocal.

- a. $-\frac{2}{11}$
 b. $-\frac{3}{11}$
 c. $-\frac{4}{11}$
 d. $-\frac{5}{11}$
 e. $-\frac{6}{11}$

45. <9.3F> Divide.

- a. $-\frac{2}{11} \div \frac{3}{11}$
 b. $-\frac{2}{11} \div \frac{4}{11}$
 c. $-\frac{2}{11} \div \frac{5}{11}$
 d. $-\frac{2}{11} \div \frac{6}{11}$
 e. $-\frac{2}{11} \div \frac{7}{11}$

46. <9.3F> Divide.

- a. $\frac{-2.2}{1.1}$
 b. $\frac{-3.3}{1.1}$
 c. $\frac{-4.4}{1.1}$
 d. $\frac{-5.5}{1.1}$
 e. $\frac{-6.6}{1.1}$

47. <9.3F> Divide.

- a. $\frac{-1.1}{-2.2}$
 b. $\frac{-1.1}{-3.3}$
 c. $\frac{-1.1}{-4.4}$
 d. $\frac{-1.1}{-5.5}$
 e. $\frac{-1.1}{-6.6}$

48. <9.3F> Divide.

- a. $\frac{2.2}{-1.1}$
 b. $\frac{3.3}{-1.1}$
 c. $\frac{4.4}{-1.1}$
 d. $\frac{5.5}{-1.1}$
 e. $\frac{6.6}{-1.1}$

49. <9.3H> Classify the given numbers by placing a check mark in the appropriate row(s).

	a.	b.	c.	d.	e.
	3.7	$\sqrt{121}$	0. $\overline{56}$	$-3\frac{1}{5}$	$\sqrt{21}$
Natural number					
Whole number					
Integer					
Rational number					
Irrational number					
Real number					

50. <9.4A> Find the value of:

- a. $-\frac{7}{2} \cdot 2 - 5$
 b. $-\frac{7}{3} \cdot 3 - 6$
 c. $-\frac{7}{4} \cdot 4 - 7$
 d. $-\frac{7}{5} \cdot 5 - 8$
 e. $-\frac{7}{6} \cdot 6 - 9$

51. <9.4A> Find the value of:

- a. $-30 \div \frac{3}{4} - (3 + 4)$
 b. $-30 \div \frac{3}{5} - (3 + 4)$
 c. $-30 \div \frac{3}{7} - (3 + 4)$
 d. $-30 \div \frac{3}{8} - (3 + 4)$
 e. $-30 \div \frac{3}{9} - (3 + 4)$

52. <9.4A> Find the value of:

- a. $-64 \div 4 \cdot 2 + 3(5 - 3) - 4 \cdot \frac{3}{4}$
 b. $-64 \div 8 \cdot 2 + 3(5 - 3) - 8 \cdot \frac{3}{8}$
 c. $-64 \div 16 \cdot 2 + 3(5 - 3) - 16 \cdot \frac{3}{16}$
 d. $-64 \div 32 \cdot 2 + 3(5 - 3) - 32 \cdot \frac{3}{32}$
 e. $-64 \div 64 \cdot 2 + 3(5 - 3) - 64 \cdot \frac{3}{64}$

53. <9.4B> Find the value of:

- a. $-6^2 + \frac{3(4 - 8)}{2} + 10 \div 5$
 b. $-7^2 + \frac{3(4 - 8)}{2} + 20 \div 5$
 c. $-7^2 + \frac{3(4 - 8)}{2} + 30 \div 5$
 d. $-8^2 + \frac{3(4 - 8)}{2} + 40 \div 5$
 e. $-9^2 + \frac{3(4 - 8)}{2} + 50 \div 5$

Practice Test Chapter 9

(Answers on page 603)

Visit www.mhhe.com/bello to view helpful videos that provide step-by-step solutions to several of the problems below.

Consider the set $\{-4, -3, 0, 3, 4\}$.

- List the negative numbers in the set.
 - List the positive numbers in the set.
 - List the integers in the set.
- Write the integer that represents the given situation.
 - A scuba diver is 30 feet below the surface.
 - A bird is flying at 500 feet.
- Graph the integers $-4, 0,$ and 3 on the number line.

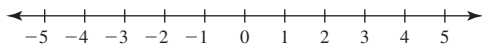

Find the additive inverse.

6. a. $\frac{9}{2}$ b. -3.8

Find each value.

8. a. $\left|-\frac{4}{9}\right|$ b. $|3.7|$

Add.

10. a. $-8.9 + 4.7 = \underline{\hspace{2cm}}$ b. $7.3 + (-9.9) = \underline{\hspace{2cm}}$

12. a. $-\frac{2}{9} + \frac{8}{9} = \underline{\hspace{2cm}}$ b. $\frac{2}{5} + \left(-\frac{5}{8}\right) = \underline{\hspace{2cm}}$

Subtract.

13. a. $-5.2 - (-4.1) = \underline{\hspace{2cm}}$

b. $-1.5 - (-7.8) = \underline{\hspace{2cm}}$

Multiply.

15. a. $-3.1 \cdot 4.4$ b. $-1.2 \cdot (-2.3)$

Find the reciprocal.

17. $-\frac{9}{4}$

Divide.

18. a. $\frac{2}{5} \div \left(-\frac{3}{4}\right)$ b. $-\frac{5}{6} \div \left(-\frac{7}{2}\right)$

20. a. $\frac{-3.2}{-19.2}$ b. $\frac{4.2}{-1.4}$

Find each value.

21. a. $(-7)^2$ b. -7^2

Find the value of:

23. $-90 \div \frac{3}{4} - (6 + 7)$

24. $-32 \div 4 \cdot 2 + 5(5 - 3) - 7 \cdot \frac{3}{7}$

25. $-3^2 + \frac{5(4 - 8)}{2} + 54 \div 6$

- Describe how the integers are used in the given situation.

Average High Temperature MINNEAPOLIS-ST. PAUL				
Jan.	Feb.	Mar.	Apr.	May
-6	-3	4	13	20

Source: National Weather Service, San Francisco. Data collected through 1993.

- Fill in the blank with $<$ or $>$ to make the statement true.

a. -4 _____ -2 b. -2 _____ -5

7. a. $-4\frac{1}{4}$ b. 9.2

9. a. $\left|-5\frac{1}{2}\right|$ b. $|-9.2|$

11. $-3.5 + (-5.1) = \underline{\hspace{2cm}}$

14. a. $\frac{2}{9} - \left(-\frac{1}{9}\right) = \underline{\hspace{2cm}}$ b. $-\frac{5}{6} - \frac{7}{4} = \underline{\hspace{2cm}}$

16. a. $-\frac{3}{5} \cdot \frac{9}{2}$ b. $\frac{5}{7} \cdot \left(-\frac{5}{8}\right)$

19. a. $-\frac{3}{11} \div \frac{5}{11}$ b. $\frac{-3.2}{1.6}$

- Classify the given numbers by placing a check mark in the appropriate row(s).

	a.	b.	c.	d.	e.
	7.9	$\sqrt{169}$	0.34	$-9\frac{1}{5}$	$\sqrt{23}$
Natural number					
Whole number					
Integer					
Rational number					
Irrational number					
Real number					

> Answers to Practice Test Chapter 9

Answer	If You Missed		Review																										
	Question	Section	Examples	Page																									
1. a. -4, -3 b. 3, 4 c. -4, -3, 0, 3, 4	1	9.1	1	551																									
2. Listing the average high temperature in Minneapolis-St. Paul.	2	9.1	2	552																									
3. a. -30 ft b. +500 ft	3	9.1	3	552																									
4. 	4	9.1	4	553																									
5. a. < b. >	5	9.1	5	553																									
6. a. $-\frac{9}{2}$ b. 3.8	6	9.1, 9.3	6, 1	554, 576																									
7. a. $4\frac{1}{4}$ b. -9.2	7	9.1, 9.3	6, 1	554, 576																									
8. a. $\frac{4}{9}$ b. 3.7	8	9.1, 9.3	7, 2	555, 576																									
9. a. $5\frac{1}{2}$ b. 9.2	9	9.1, 9.3	7, 2	555, 576																									
10. a. -4.2 b. -2.6	10	9.1, 9.3	11, 3	557-558, 577																									
11. -8.6	11	9.1, 9.3	11, 3	557-558, 577																									
12. a. $\frac{2}{3}$ b. $-\frac{9}{40}$	12	9.1, 9.3	11, 4	557-558, 577																									
13. a. -1.1 b. 6.3	13	9.1, 9.3	12, 5	559, 578																									
14. a. $\frac{1}{3}$ b. $-\frac{31}{12}$	14	9.1, 9.3	12, 5	559, 578																									
15. a. -13.64 b. 2.76	15	9.2, 9.3	1, 6	568, 578																									
16. a. $-\frac{27}{10}$ b. $-\frac{25}{56}$	16	9.2, 9.3	1, 6	568, 578																									
17. $-\frac{4}{9}$	17	9.3	7	579																									
18. a. $-\frac{8}{15}$ b. $\frac{5}{21}$	18	9.2, 9.3	2, 8	568, 579																									
19. a. $-\frac{3}{5}$ b. -2	19	9.2, 9.3	2, 9	568, 580																									
20. a. $\frac{1}{6}$ b. -3	20	9.2, 9.3	2, 9	568, 580																									
21. a. 49 b. -49	21	9.2	3	569																									
22. a. b. c. d. e.	22	9.3	11	583																									
<table style="width: 100%; border-collapse: collapse;"> <tr> <td style="padding: 2px 10px;">7.9</td> <td style="padding: 2px 10px;">$\sqrt{169}$</td> <td style="padding: 2px 10px;">0.34</td> <td style="padding: 2px 10px;">$-9\frac{1}{5}$</td> <td style="padding: 2px 10px;">$\sqrt{23}$</td> </tr> <tr> <td></td> <td style="text-align: center;">✓</td> <td></td> <td></td> <td></td> </tr> <tr> <td></td> <td style="text-align: center;">✓</td> <td></td> <td></td> <td></td> </tr> <tr> <td style="text-align: center;">✓</td> <td style="text-align: center;">✓</td> <td style="text-align: center;">✓</td> <td style="text-align: center;">✓</td> <td></td> </tr> <tr> <td style="text-align: center;">✓</td> <td style="text-align: center;">✓</td> <td style="text-align: center;">✓</td> <td style="text-align: center;">✓</td> <td style="text-align: center;">✓</td> </tr> </table>	7.9	$\sqrt{169}$	0.34	$-9\frac{1}{5}$	$\sqrt{23}$		✓					✓				✓	✓	✓	✓		✓	✓	✓	✓	✓				
7.9	$\sqrt{169}$	0.34	$-9\frac{1}{5}$	$\sqrt{23}$																									
	✓																												
	✓																												
✓	✓	✓	✓																										
✓	✓	✓	✓	✓																									
23. -133	23	9.4	1, 4	589, 590																									
24. -9	24	9.4	5	590																									
25. -10	25	9.4	7, 8	591-592																									

Cumulative Review Chapters 1–9

- Simplify: $9 \div 3 \cdot 3 + 5 - 4$
- Round 449.851 to the nearest ten.
- Divide: $90 \div 0.13$. (Round answer to two decimal places.)
- Solve for y : $7.2 = 0.9y$
- Solve for z : $6 = \frac{z}{6.6}$
- Solve the proportion: $\frac{c}{4} = \frac{4}{64}$
- Write 23% as a decimal.
- 80% of 40 is what number?
- What percent of 4 is 2?
- 30 is 40% of what number?
- Find the simple interest earned on \$900 invested at 4.5% for 4 years.
- Referring to the circle graph, which is the main source of pollution?

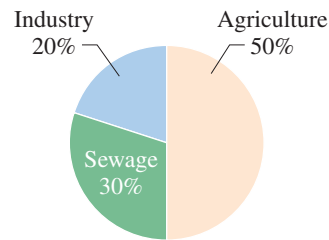

- Make a circle graph for this data.

Family Budget	(Monthly)
Savings (S)	\$200
Housing (H)	\$900
Food (F)	\$400
Clothing (C)	\$500

- The following table shows the distribution of families by income in Chicago, Illinois.

Income Level	Percent of Families
\$0–9,999	3
10,000–14,999	6
15,000–19,999	20
20,000–24,999	45
25,000–34,999	12
35,000–49,999	6
50,000–79,999	4
80,000–119,999	3
120,000 and over	1

- The following graph represents the monthly average temperature for 7 months of the year. How much higher is the average temperature in June than it is in May?

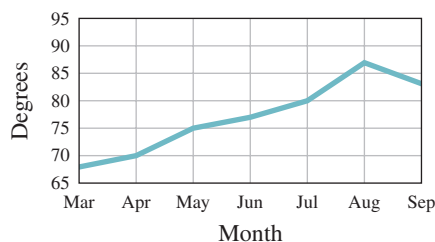

What percent of the families in Chicago have incomes between \$50,000 and \$79,999?

- The number of hours required in each discipline of a college core curriculum is represented by the following circle graph. What percent of these hours is in Art and English combined?

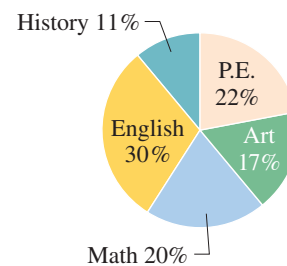

- 17.** What is the mode for the following numbers?
8, 30, 6, 1, 26, 24, 6, 10, 6

- 19.** What is the median for the following numbers?
4, 2, 23, 19, 3, 2, 29, 10, 2, 2, 14

- 21.** Convert 16 inches to feet.

- 23.** Convert 6 feet to inches.

- 25.** Find the perimeter of a rectangle 4.4 inches long by 2.3 inches wide.

- 27.** Find the area of a triangular piece of cloth whose base is 16 centimeters and whose height is 20 centimeters.

- 29.** Find the area of the trapezoid.

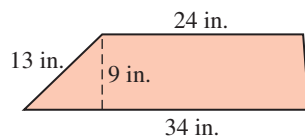

- 31.** Find the volume of a sphere with a 9-inch radius. Use 3.14 for π and round the answer to two decimal places.

- 33.** If in triangle ABC , $m \angle A = 30^\circ$ and $m \angle B = 25^\circ$, what is $m \angle C$?

- 35.** Find the hypotenuse c of the given triangle:

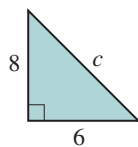

- 37.** Find: $|-9.8|$

- 39.** Add: $\frac{1}{5} + \left(-\frac{1}{7}\right)$

- 41.** Subtract: $-\frac{1}{5} - \frac{1}{6}$

- 43.** Divide: $-\frac{9}{8} \div \frac{5}{8}$

- 18.** What is the mean for the following numbers?
11, 21, 7, 21, 18, 21, 4, 27, 16, 21, 20

- 20.** Convert 9 yards to inches.

- 22.** Convert 17 feet to yards.

- 24.** Convert 170 meters to decimeters.

- 26.** Find the circumference of a circle whose radius is 8 feet. Use 3.14 for π and round the answer to two decimal places.

- 28.** Find the area of a circle with a radius of 6 centimeters. Use 3.14 for π and round the answer to two decimal places.

- 30.** Find the volume of a box 5 centimeters wide, 4 centimeters long, and 10 centimeters high.

- 32.** Classify the angle:

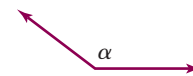

- 34.** Find $\sqrt{4900}$.

- 36.** Find the additive inverse of $-4\frac{3}{4}$.

- 38.** Add: $-7.2 + (-2.6)$

- 40.** Subtract: $-4.2 - (-8.5)$

- 42.** Multiply: $-\frac{3}{8} \cdot \frac{8}{9}$

- 44.** Evaluate: $(-9)^2$

This page intentionally left blank

Section

Chapter

- 10.1** Introduction to Algebra
- 10.2** The Algebra of Exponents
- 10.3** Scientific Notation
- 10.4** Solving Linear Equations
- 10.5** Applications: Word Problems

10

ten

▶ Introduction to Algebra

The Human Side of Mathematics

What is algebra and where did it come from? The word *algebra* is the European derivation of *al-jabr*, part of the title of a book written by Abu Ja'far Muhammad ibn Musa al-Khwarizmi, born in Baghdad probably in 820. Some historians suggest that al-Khwarizmi means Muhammad the son of Moses of Khwarizmi and was really born in the city of Khwarizm, south of the Aral Sea in central Asia. What is indeed certain is that he wrote a book *Hisab al-jabr w'al-muqabala*, "The Science of Reunion and Reduction" or "Restoring and Simplification," from which the name "algebra" is derived. What about the "reunion" and the "reduction"? The reduction is carried out using two operations: *al-jabr* and *al-muqabala*, where *al-jabr* means "completion": the process of removing negative terms from an equation. Using one of al-Khwarizmi's examples, *al-jabr* changes $x^2 = 40x - 4x^2$ into $5x^2 = 40x$. (We do this now by simply *adding* $4x^2$ to both sides of the equation.) The term *al-muqabala* means "balancing." Thus, *al-muqabala* balances

$$50 + 3x + x^2 = 29 + 10x \tag{1}$$

to $21 + x^2 = 7x \tag{2}$

In modern terms, we simply say that we *subtract* 29 and *subtract* 3x from both sides of equation (1) to obtain equation (2).



10.1

Introduction to Algebra

▶ Objectives

You should be able to:

- A > Identify the terms in an expression.
- B > Use the distributive property to simplify an expression.
- C > Use the distributive property to factor an expression.
- D > Combine like terms in an expression.
- E > Remove parentheses in an expression.
- F > Evaluate expressions.

▶ To Succeed, Review How To . . .

Add, subtract, and multiply rational numbers. (pp. 577–578)

▶ Getting Started

The poster uses the language of algebra to tell you how to be successful! The letters X , Y , and Z are used as *placeholders*. In algebra, we use the letters of the alphabet as **placeholders, unknowns, or variables**. By tradition, the letters t , u , v , w , x , y , and z are frequently used for unknowns. Of course, we use the same symbols as in arithmetic to denote the operations of addition (+) and subtraction (−). In algebra, multiplication is indicated by using the raised dot, \cdot , using parentheses, (), or simply writing the variables next to each other. Thus, the *product* of a and b can be written as:

$$a \cdot b, (a)(b), a(b), (a)b, \text{ or } ab$$

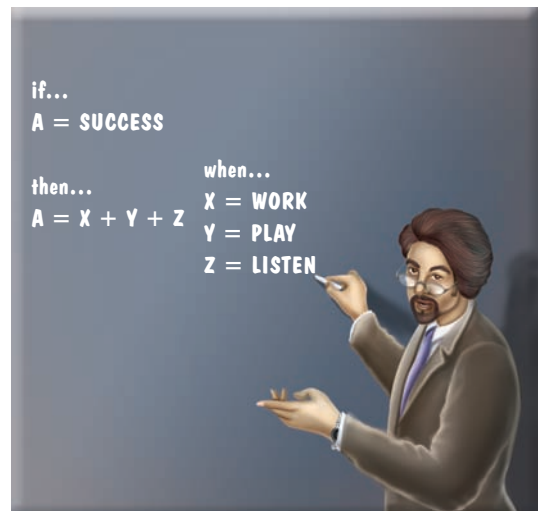

A > Expressions and Terms

How do we express mathematical ideas in the language of algebra? By using expressions, of course! As stated in the *Getting Started*, in algebra we use letters of the alphabet as placeholders (variables) for unknown value(s). An **expression** is a collection of numbers and letters connected by operation signs. Thus, xy^2 , $x + y$, and $3x^2 - 2y + 9$ are expressions. In these expressions, the parts that are to be added or subtracted are called **terms**.

1. The expression xy^2 has *one* term (it is a monomial), xy^2 .
2. The expression $x + y$ has *two* terms (a binomial), x and y .
3. The expression $3x^2 - 2y + 9$ has *three* terms (a trinomial), $3x^2$, $-2y$, and $+9$ (or simply 9, without the + sign).

EXAMPLE 1 Identifying the terms of an expression

What are the terms in $5y^3 + 2y - 3$?

SOLUTION 1 The terms are $5y^3$, $2y$, and -3 .

PROBLEM 1

What are the terms in $8z^2 - 5z + 2$?

Answers to PROBLEMS

1. $8z^2$, $-5z$, and 2

B > The Distributive Property

If you wish to multiply a real number by a *sum*, you can either add and then multiply or multiply and then add. For example, suppose you wish to multiply a number, say 7, by the sum of 4 and 5. The product $7 \cdot (4 + 5)$ can be obtained in two ways:

$$\begin{array}{r} 7 \cdot (4 + 5) \\ 7 \cdot \quad 9 \\ \quad 63 \end{array} \left. \vphantom{\begin{array}{r} 7 \cdot (4 + 5) \\ 7 \cdot \quad 9 \\ \quad 63 \end{array}} \right\} \text{Adding within the parentheses first}$$

$$\begin{array}{r} (7 \cdot 4) + (7 \cdot 5) \\ \underline{28} \quad + \quad \underline{35} \\ \quad 63 \end{array} \left. \vphantom{\begin{array}{r} (7 \cdot 4) + (7 \cdot 5) \\ \underline{28} \quad + \quad \underline{35} \\ \quad 63 \end{array}} \right\} \text{Multiplying and then adding}$$

Thus,

$$7 \cdot (4 + 5) = (7 \cdot 4) + (7 \cdot 5)$$

The parentheses in $(7 \cdot 4) + (7 \cdot 5)$ can be omitted as long as we agree that *multiplications must be done first*. The fact that $a(b + c) = ab + ac$ is called the **distributive property of multiplication over addition**. There is also a distributive property of multiplication over subtraction. When we multiply a real number by a *difference*, we can either subtract and then multiply or multiply and then subtract. These two properties are stated next.

DISTRIBUTIVE PROPERTY FOR MULTIPLICATION

For any real numbers a , b , and c ,

$$a(b + c) = ab + ac \quad \text{and} \quad a(b - c) = ab - ac$$

EXAMPLE 2 Using the distributive property

Multiply.

a. $2(x + 2y)$

b. $5(3x - 4y)$

c. $-3(x - 2y + z)$

SOLUTION 2

a. $2(x + 2y) = 2 \cdot x + 2 \cdot 2y = 2x + 4y$

b. $5(3x - 4y) = 5 \cdot 3x - 5 \cdot 4y = 15x - 20y$

c. $-3(x - 2y + z) = -3 \cdot x - (-3) \cdot (2y) - 3 \cdot z = -3x + 6y - 3z$

PROBLEM 2

Multiply.

a. $3(a + 5b)$

b. $6(4a - 5b)$

c. $-2(a - 3b + c)$

C > Factoring Out the Greatest Common Factor

Do you remember how to factor 15? To *factor* 15, we write it as the product $5 \cdot 3$. Thus, factoring is the reverse of multiplying.

FACTOR

To factor an expression is to find an equivalent expression that is a product.

Now, look at Example 2(a). To factor $2x + 4y$, we would write it as the product $2(x + 2y)$. Similarly, to factor $15x - 20y$ we write it as $5(3x - 4y)$. Note that in each case, we removed the **largest** (greatest) common factor (GCF for short).

EXAMPLE 3 Factoring out the GCF

Factor.

a. $3x - 6y$

b. $ax + ay - az$

c. $10x - 20y - 30z$

PROBLEM 3

Factor.

a. $5a - 15b$

b. $ab + ac - ad$

c. $6a - 12b + 18c$

(continued)

Answers to PROBLEMS

2. a. $3a + 15b$ b. $24a - 30b$ c. $-2a + 6b - 2c$ 3. a. $5(a - 3b)$ b. $a(b + c - d)$ c. $6(a - 2b + 3c)$

SOLUTION 3

- a. $3x - 6y = 3 \cdot x - 3 \cdot 2y = 3(x - 2y)$
 b. $ax + ay - az = a \cdot x + a \cdot y - a \cdot z = a(x + y - z)$
 c. $10x - 20y - 30z = 10 \cdot x - 10 \cdot 2y - 10 \cdot 3z = 10(x - 2y - 3z)$

Note that $5(2x - 4y - 6z)$ is also a factored form for $10x - 20y - 30z$ but $5(2x - 4y - 6z)$ is not **completely factored**. When we say *factor*, we must factor out the *greatest* common factor. Moreover, $-5x + 30$ is factored as $-5(x - 6)$ **not** $5(-x + 6)$.

D > Combining Like Terms*

One of the fundamental operations in algebra is **combining like terms**. Combining like terms is really simple; you only have to be sure that the variable parts of the terms to be combined are **identical** and then add (or subtract) the coefficients involved. Thus,

$$2a + 3a = (2 + 3)a = 5a$$

and

$$2b + 3b = (2 + 3)b = 5b$$

Similarly,

$$5a - 2a = (5 - 2)a = 3a$$

and

$$5b - 2b = (5 - 2)b = 3b$$

However, $2a^2 + 3a$ and $5b^2 - 2b$ *cannot* be simplified any further, since the terms in $2a^2 + 3a$ and $5b^2 - 2b$ are **not** like terms.

EXAMPLE 4 Combining like terms (simplify)

Simplify.

- a. $7x - 2x$ b. $3x + 5y - x + 4y$
 c. $0.2x + 0.31y - 0.6x + 0.23y$ d. $\frac{1}{7}x + \frac{3}{5}y + \frac{4}{7}x - \frac{2}{5}y$

SOLUTION 4

- a. $7x - 2x = (7 - 2)x = 5x$
 b. $3x + 5y - x + 4y = 3x - x + 5y + 4y$ Since $5y - x = -x + 5y$
 $= (3 - 1)x + (5 + 4)y = 2x + 9y$
 c. $0.2x + 0.31y - 0.6x + 0.23y = 0.2x - 0.6x + 0.31y + 0.23y$
 $= (0.2 - 0.6)x + (0.31 + 0.23)y$
 $= -0.4x + 0.54y$
 d. $\frac{1}{7}x + \frac{3}{5}y + \frac{4}{7}x - \frac{2}{5}y = \frac{1}{7}x + \frac{4}{7}x + \frac{3}{5}y - \frac{2}{5}y$
 $= \left(\frac{1}{7} + \frac{4}{7}\right)x + \left(\frac{3}{5} - \frac{2}{5}\right)y = \frac{5}{7}x + \frac{1}{5}y$

PROBLEM 4

Simplify.

- a. $6a - 2a$
 b. $5a + 7b - a + 2b$
 c. $0.3a + 0.21b - 0.8a + 0.32b$
 d. $\frac{1}{5}a + \frac{4}{7}b + \frac{2}{5}a - \frac{1}{7}b$

E > Removing Parentheses

Sometimes it is necessary to remove parentheses before combining like terms. Thus, to combine like terms in

$$(4x + 2) + (5x + 1)$$

we have to remove the parentheses first. As long as the parentheses are preceded by a *plus* sign (or no sign at all), we can simply remove the parentheses. That is,

Answers to PROBLEMS

4. a. $4a$ b. $4a + 9b$
 c. $-0.5a + 0.53b$ d. $\frac{3}{5}a + \frac{3}{7}b$

* For a more rigorous development, see the *Using Your Knowledge* section.

REMOVING PARENTHESES PRECEDED BY + OR NO SIGN

If a and b are real numbers, then

$$(a + b) = a + b$$

Thus,

$$\begin{aligned} (4x + 2) + (5x + 1) &= 4x + 2 + 5x + 1 \\ &= 9x + 3 \end{aligned}$$

(Arrows in the original image point from 4x to 5x and from 2 to 1, both labeled "like terms".)

What about $-(a + b)$? Since $-a = -1 \cdot a$, then, by the distributive property, $-(a + b) = -1 \cdot (a + b) = -1 \cdot a + (-1) \cdot b = -a - b$. That is,

$$-(a + b) = -a - b$$

Thus,

$$\begin{aligned} (5a + 3b) - (4a + 7b) &= 5a + 3b - 4a - 7b \\ &= a - 4b \end{aligned}$$

(Arrows in the original image point from 5a to -4a and from 3b to -7b, both labeled "like terms".)

Note that when a minus sign precedes the parentheses, we change the sign of each of the terms inside using the property. You can think of this as multiplying each term by -1 .

REMOVING PARENTHESES PRECEDED BY -

If a and b are real numbers, then

$$-(a - b) = -a + b$$

These two rules can be summarized as follows:

REMOVING PARENTHESES

1. If there is a *plus* sign (or no sign) in *front* of the parentheses, simply remove the parentheses.
2. If there is a *minus* sign in *front* of the parentheses, the parentheses can be removed by *changing the sign of each* of the terms *inside* the parentheses.

For example,

$$\begin{aligned} -(a + 7b) &= -a - 7b \\ -(2a + 4b) &= -2a - 4b \\ -(a - 3b) &= -a + 3b \\ -(4a - 7b) &= -4a + 7b \end{aligned}$$

EXAMPLE 5 Removing parentheses

Simplify.

a. $(3a + 5b) - (a + 2b)$

b. $(5a + 2b) - (6a - 3b)$

SOLUTION 5

$$\begin{aligned} \text{a. } (3a + 5b) - (a + 2b) &= 3a + 5b - a - 2b \\ &= 2a + 3b \end{aligned}$$

(Arrows in the original image point from 3a to -a and from 5b to -2b.)

$$\begin{aligned} \text{b. } (5a + 2b) - (6a - 3b) &= 5a + 2b - 6a + 3b \\ &= -a + 5b \end{aligned}$$

(Arrows in the original image point from 5a to -6a and from 2b to +3b.)

PROBLEM 5

Simplify.

a. $(4a + 5b) - (a + 3b)$

b. $(6a + 5b) - (8a - 2b)$

Answers to PROBLEMS

5. a. $3a + 2b$ b. $-2a + 7b$

EXAMPLE 6 Removing parentheses

Simplify.

a. $-(-a + 2b) - 5a$

b. $-(-a^2 - 3b) + a$

SOLUTION 6

a.
$$\begin{aligned} -(-a + 2b) - 5a &= a - 2b - 5a \\ &= -4a - 2b \end{aligned}$$

b.
$$-(-a^2 - 3b) + a = a^2 + 3b + a$$

(Note: a^2 and a are not combined, since they are not like terms.)**PROBLEM 6**

Simplify.

a. $-(-2x + 5y) - 6x$

b. $-(-2x^2 - 3y) + 3x$

F > Evaluating Expressions

Sometimes in algebra, we have to substitute a number for a variable in an expression. This process is called **evaluating** the expression. For example, the number of students in your class is $M + W$, where M is the number of men and W is the number of women in your class. If $M = 20$ and $W = 18$, then the number of students in your class is $20 + 18$ or 38. To find the answer 38 we evaluated the expression $M + W$ using $M = 20$ and $W = 18$.

EXAMPLE 7 Evaluating expressions

Evaluate:

a. $x + y$ when $x = 3$ and $y = -7$

b. $4y + x$ when $x = 2$ and $y = 5$

c. $-(y + z)$ when $y = 7$ and $z = 4$

SOLUTION 7

a. Substituting $x = 3$ and $y = -7$, $x + y = 3 + (-7) = -4$.

b. Substituting $x = 2$ and $y = 5$, $4y + x = 4(5) + 2 = 22$.

c. Substituting $y = 7$ and $z = 4$, $-(y + z) = -(7 + 4) = -11$.

PROBLEM 7

Evaluate:

a. $a + b$ when $a = 4$ and $b = -9$

b. $5a + b$ when $a = 3$ and $b = 5$

c. $-(a + b)$ when $a = 6$ and $b = 3$

GREEN MATH**EXAMPLE 8** Recovered and recycled garbage

The graph shows the total materials recovered from garbage (blue) (in millions of tons) and can be approximated by $R = 2.2N + 69$ where N is the number of years after 2000.

- Find the amount of materials (in millions of tons) recovered in 2000.
- Find how much was recovered in 2007.
- Based on the formula, what is the amount of materials that will be recovered in 2010?

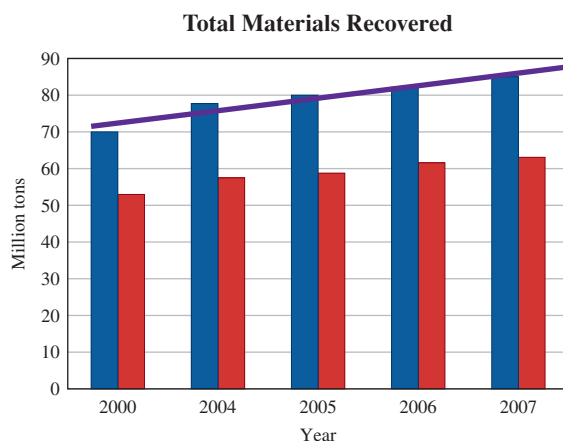
**PROBLEM 8**

The total materials actually recycled (in millions of tons) shown by the red bars can be approximated by $A = 1.5N + 52$

- Find the amount of materials (in millions of tons) that were actually recycled in 2000.
- Find the amount of materials (in millions of tons) that were recycled in 2006.
- Based on the formula, what would be your prediction for the number of tons that will be recycled in 2010?

Answers to PROBLEMS

6. a. $-4x - 5y$ b. $2x^2 + 3x + 3y$ 7. a. -5 b. 20 c. -9 8. a. 52 million tons b. 61 million tons c. 67 million tons

SOLUTION 8

- a. The year 2000 corresponds to $N = 0$ (0 years after 2000).
Letting $N = 0$ in the formula, we have $R = 2.2(0) + 69 = 69$
This means that 69 million tons of materials were recovered in the year 2000.
- b. The year 2007 corresponds to $N = 7$ (7 years after 2000).
Letting $N = 7$ in the formula gives $R = 2.2(7) + 69 = 15.4 + 69 = 84.4$, which means that 84.4 million tons were recovered in 2007.
- c. The year 2010 corresponds to $N = 10$ (10 years after 2000).
Letting $N = 10$ in the formula gives $R = 2.2(10) + 69 = 22 + 69 = 91$. Thus, we predict that 91 million tons of materials will be recovered in 2010.

> Exercises 10.1

> Practice Problems > Self-Tests
> Media-rich eBooks > e-Professors > Videos

< A > Expressions and Terms In Problems 1–6, list the terms in the expression.

1. $2x - 3$

2. $3y - 6$

3. $-3x^2 + 0.5x - 6$

4. $-5y^2 - 0.2y + 8$

5. $\frac{1}{5}x - \frac{3}{4}y + \frac{1}{8}z$

6. $\frac{3}{4}x^2 - \frac{1}{5}y + \frac{4}{9}z^3$

< B > The Distributive Property In Problems 7–30, multiply.

7. $3(2x + y)$

8. $5(3x + y)$

9. $3(a - b)$

10. $4(a - b)$

11. $-5(2x - y)$

12. $-6(3x - y)$

13. $8(3x^2 + 2)$

14. $7(2x^2 + 5)$

15. $-6(2x^2 - 3)$

16. $-2(3x^2 - 4)$

17. $3(2x^2 + 3x + 5)$

18. $5(3x^2 + 2x + 2)$

19. $-5(3x^2 - 2x - 3)$

20. $-6(3x^2 - 5x - 4)$

21. $0.5(x + y - 2)$

22. $0.8(a + b - 6)$

23. $\frac{6}{5}(a - b + 5)$

24. $\frac{2}{3}(x - y + 4)$

25. $-2(x - y + 4)$

26. $-4(a - b + 8)$

27. $-0.3(x + y - 6)$

28. $-0.2(a + b - 3)$

29. $-\frac{5}{2}(a - 2b + c - 1)$

30. $-\frac{4}{7}(2a - b + 3c - 5)$

< C > Factoring Out the Greatest Common Factor In Problems 31–40, factor.

31. $3x + 15$

32. $5x + 45$

33. $9y - 18$

34. $11y - 33$

35. $-5y + 20$

36. $-4y + 28$

37. $-3x - 27$

38. $-6x - 36$

39. $bx - by + bz$

40. $cx + cy - cz$

< D > Combining Like Terms In Problems 41–60, combine like terms (simplify).

41. $8a + 2a$

42. $3b + 9b$

43. $4x + 2x$

44. $5y + 9y$

45. $8a^2 + 2a^2$

46. $8a^3 + 3a^3$

47. $13x - 2x$

50. $4z^3 - 3z^3$

53. $13x + 5 - 2y - 3x - 9 - y$

55. $3.9a + 4.5b - 3 - 1.5a - 7.5b - 4$

57. $\frac{1}{7}a - \frac{1}{5}b + \frac{3}{7}a - \frac{3}{5}b$

59. $-\frac{1}{8}x - \frac{3}{11}b + \frac{3}{8}x - \frac{2}{11}b$

48. $5y - 5y$

51. $7x + 3y - 2x$

54. $8a - 2b + 4 - 3a - b - 7$

56. $-2.8a + 5 - 4.2b - 2 + 3.8a - 1.3b$

58. $\frac{3}{5}a - \frac{4}{11}b + \frac{1}{5}a - \frac{3}{11}b$

60. $-\frac{3}{7}x - \frac{2}{9}a + \frac{5}{7}x - \frac{1}{9}a$

49. $17y^2 - 12y^2$

52. $8x - 3y - 4x$

< E > Removing Parentheses In Problems 61–70, simplify.

61. $-(-a + 5b) - (7a + 8b)$

63. $-(-2a + b) - (4b + a)$

65. $-(-b^2 - 2a) + (3a - 4b^2)$

67. $-(-a^2 - 3b) + (2a^2 - 5b)$

69. $-(-2b^2 - 3a) - (6b^2 - 5a)$

62. $-(-a + 3b) - (9b + 2a)$

64. $-(-3b + a) - (5a + 2b)$

66. $-(-a^2 - 3b) + (4b - 3a^2)$

68. $-(-b^2 - 3a) + (4b^2 - 7a)$

70. $-(-3a^2 - 5a) - (7a^2 - 8a)$

< F > Evaluating Expressions In Problems 71–80, evaluate the expression.

71. $m + n$ when $m = 7$ and $n = -9$

73. $-(u + v)$ when $u = 5$ and $v = 3$

75. $3x^2y$ when $x = 3$ and $y = 5$

77. $\frac{x}{3} + x$ when $x = 6$

79. LWH when $L = 2$, $W = 3.2$, and $H = 5$

72. $5r + s$ when $r = 4$ and $s = 5$

74. $4y^2$ when $y = 5$

76. $3a - b$ when $a = -1$ and $b = 4$

78. $\frac{x - y}{3}$ when $x = 4$ and $y = -5$

80. $\frac{5}{9}(F - C)$ when $F = 212$ and $C = 32$

Books, maps, magazines, newspapers, and sheet music The table shows the amount of money spent annually (in billions of dollars) over a 5-year period on books and maps (column 2) and can be approximated by

$$B = 1.7x + 27.8 \text{ (in billions of dollars)}$$

The table also shows the amount spent on magazines, newspapers, and sheet music and can be approximated by

$$M = 0.52x + 32.3 \text{ (billion dollars)}$$

where x is the year number.

	Books, Maps	Mag, News, Sheet Music
1	28.8	32.1
2	31.6	33.5
3	33.7	35.0
4	34.6	34.5
5	35.8	34.2

81. Evaluate B for $x = 1, 2, 3, 4,$ and 5 . How close are the results to the values given in the table?

82. Predict the amount of money B that will be spent on books and maps in 10 years.

83. Evaluate M for $x = 1, 2, 3, 4,$ and 5 . How close are the results to the values given in the table?

84. Predict the amount of money M that will be spent on magazines, newspapers, and sheet music in 10 years.

Source: U.S. Bureau of Economic Analysis, *Survey of Current Business*, January 2004; <http://www.census.gov/prod/2004pubs/04statab/arts.pdf>.

Vehicle insurance According to the Bureau of Labor Statistics the amount of money I spent annually (in billions of dollars) on vehicle insurance by persons between 25 and 34 years of age is as shown in the table and can be approximated by

$$I = 50.5x + 665.7 \text{ (billion dollars)}$$

where x is the year number (1, 2, 3, 4, or 5).

	Ins	Alc Bev
1	705	365
2	774	431
3	822	393
4	872	395
5	910	446

Alcohol The annual amount A (in billions of dollars) spent on alcoholic beverages by persons between 25 and 34 years of age can be approximated by

$$A = 12.6x + 368.2 \text{ (billion dollars)}$$

- 87.** Evaluate A for $x = 1, 2, 3, 4,$ and 5 . How close are the results to the values given in the table?
- 88.** Predict the amount A that will be spent on alcoholic beverages by persons between 25 and 34 years of age in 10 years (see Exercise 87).

Total enrollment The graph shows the total enrollment of 18-year to 24-year-old students in degree-granting institutions and can be approximated by

$$E = 0.15N + 7.77 \text{ (millions)}$$

where N represents the number of years after 1989.

- 89.** Use the equation to find the projected number E of students enrolled in 2002 ($N = 13$). How close is your answer to the value 9.9 given in the graph?
- 90.** Use the equation to find the projected number E of students enrolled in 2014 ($N = 25$). How close is your answer to the value 11.5 given in the graph?
- 91.** The graph does not show a projected value for the year 2010. Use the equation to predict the enrollment for the year 2010 ($N = 21$).

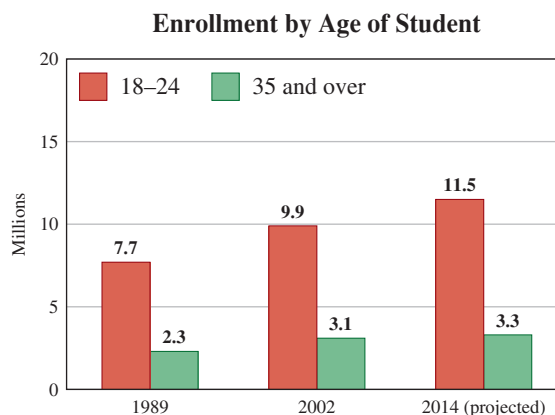

Source: U.S. Dept. of Education, NCES: Integrated Post-secondary Education Data System (IPEDS), "Fall Enrollment Survey"; http://nces.ed.gov/pubs2005/2005074_1.pdf.

Applications: Green Math

Don't discard your Paper and Paperboard Have you been recycling your paper and paperboard? The graph shows the amount of paper and paperboard *discarded* (in millions of tons) in the Municipal Waste Stream and it can be approximated by $P = -1.7N + 51$ where N is the number of years after 2000.

- 92.** Use the formula to find the amount of paper and paperboard discarded in the year 2000.
- 93.** Use the formula to find the projected number P of millions of tons of paper and paperboard to be discarded in 2020. How close is your answer to the value 17.4 given in the graph?

Stop! Don't throw those paper products away! Recycling 1 ton of paper saves 17 mature trees, 3.3 cubic yards of landfill space, 7000 gallons of water, and the equivalent of one 40-foot fir tree.

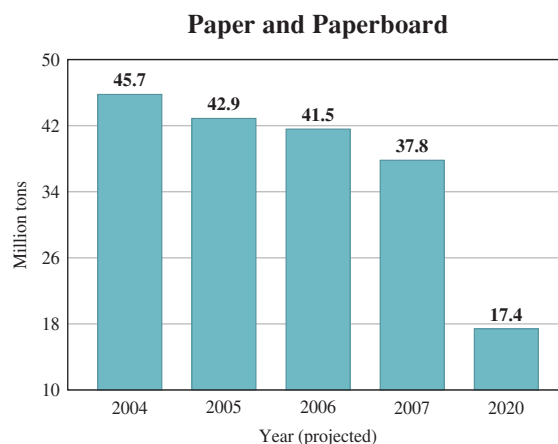

Using Your Knowledge

Properties of Numbers In this section, we will study properties of addition and multiplication that will be used to explain why we can simplify expressions. Some of these properties were mentioned in Chapter 1, and they also apply to the real numbers. The first of these properties is the commutative property, which we have mentioned previously and which states the following for any real numbers a and b .

COMMUTATIVE PROPERTY OF ADDITION

$$a + b = b + a$$

Changing the order of two addends does not change their sum.

This property is used to add two numbers without regard to the order in which the numbers are added. Thus,

$$\begin{aligned} 3 + 7 &= 7 + 3 \\ 8 + 4 &= 4 + 8 \\ 101 + 17 &= 17 + 101 \end{aligned}$$

Sometimes we have to add three or more numbers. For example, to add $4 + 8 + 2$ we can *first* add 4 and 8 and then add 2 to this result; that is,

$$(4 + 8) + 2 = 12 + 2 = 14$$

To find $4 + 8 + 2$ we could also add $8 + 2$ *first* and then add 4 to this result; that is,

$$4 + (8 + 2) = 4 + 10 = 14$$

Because the answers are the same, we see that it makes *no difference* which numbers we add first. For example,

$$3 + (4 + 6) = (3 + 4) + 6$$

and

$$7 + (3 + 6) = (7 + 3) + 6$$

Thus, for any three real numbers a , b , and c , we have the following property.

ASSOCIATIVE PROPERTY OF ADDITION

$$a + (b + c) = (a + b) + c$$

The grouping of numbers (addends) does not change their sum.

Here is how we use these two properties to simplify expressions such as $(3 + a) + 5$.

$$\begin{aligned} (3 + a) + 5 &= (a + 3) + 5 && \text{By the commutative property of addition} \\ &= a + (3 + 5) && \text{By the associative property of addition} \\ &= a + 8 \end{aligned}$$

We also have commutative and associative properties for multiplication. These properties are stated next.

COMMUTATIVE PROPERTY OF MULTIPLICATION

$$a \cdot b = b \cdot a$$

Changing the order of two factors does not change their product.

ASSOCIATIVE PROPERTY OF MULTIPLICATION

$$a(bc) = (ab)c$$

Changing the grouping of two factors does not change their product.

Thus, $4 \cdot 5 = 5 \cdot 4$ and $3 \cdot 7 = 7 \cdot 3$. Remember, to indicate the product of 4 and 5, we write $4 \cdot 5$. To indicate the product of a and b , we simply write ab . To simplify $3(4a)$ we proceed like this:

$$\begin{aligned} 3 \cdot (4a) &= (3 \cdot 4)a && \text{By the associative property of multiplication} \\ &= 12a \end{aligned}$$

Similarly, to simplify $(4a) \cdot 5$ we write

$$\begin{aligned}(4a) \cdot 5 &= 5 \cdot (4a) && \text{By the commutative property of multiplication} \\ &= (5 \cdot 4)a && \text{By the associative property of multiplication} \\ &= 20a\end{aligned}$$

How do we simplify $3a + 5a$? We need the distributive property.

DISTRIBUTIVE PROPERTY OF MULTIPLICATION

$$a(b + c) = ab + ac$$

When multiplying a number by a sum, multiply each addend by the number and then add.

By the commutative property of multiplication, we can rewrite $ab + ac$ as shown next.

DISTRIBUTIVE PROPERTY (FOR FACTORING)

$$ba + ca = (b + c)a$$

Factor the *greatest common factor* out from each term in the expression.

Now,

$$\begin{aligned}3a + 5a &= (3 + 5)a && \text{By the distributive property for factoring} \\ &= 8a\end{aligned}$$

Similarly, to simplify $5x + (3x + 2)$, we write

$$\begin{aligned}5x + (3x + 2) &= (5x + 3x) + 2 && \text{By the associative property of addition} \\ &= (5 + 3)x + 2 && \text{By the distributive property for factoring} \\ &= 8x + 2\end{aligned}$$

To simplify expressions involving a negative sign in front of the parentheses, we need the following property:

MULTIPLICATIVE PROPERTY OF -1

$$(-1)a = a(-1) = -a$$

The product of any number and -1 is the opposite of the number.

Thus,

$$\begin{aligned}-(x + 3) &= -1(x + 3) = -1 \cdot x + (-1) \cdot 3 && \text{By the distributive property for multiplication} \\ &= -x - 3\end{aligned}$$

We are now ready to simplify $10 - (2x + 5)$.

$$\begin{aligned}10 - (2x + 5) &= 10 - 1 \cdot (2x + 5) && \text{By the multiplicative property of } -1 \\ &= 10 - 1 \cdot 2x - 1 \cdot 5 && \text{By the distributive property for multiplication} \\ &= 10 - 2x - 5 && \text{Multiplying} \\ &= 5 - 2x\end{aligned}$$

Now you know the reason used to simplify some expressions.

>>> Write On

94. Write in your own words the difference between a factor and a term.
95. Write in your own words the procedure you use to combine like terms.
96. Write in your own words the procedure you use to remove parentheses when no sign or a plus sign precedes an expression within parentheses.
97. Write in your own words the procedure you use to remove parentheses when a minus sign precedes an expression within parentheses.

>>> Concept Checker

Fill in the blank(s) with the correct word(s), phrase, or mathematical statement.

- | | | |
|--|-----------------------------|----------------------------|
| 98. An _____ is a collection of numbers and letters connected by operation signs. | evaluated | variables |
| 99. The parts that are to be added or subtracted in an expression are called the _____ of the expression. | $ab + ac$ | terms |
| 100. An expression with two terms is called a _____. | binomial | monomial |
| 101. An expression with three terms is called a _____. | trinomial | $-a + b$ |
| 102. According to the distributive property, $a(b + c) =$ _____. | $a - b$ | $a - c$ |
| 103. $-(a - b) =$ _____. | sentence | $-a - b$ |
| 104. $-(a + b) =$ _____. | expression | multiplied |
| 105. If we substitute a number for a variable in an expression, we have _____ the expression. | | |

>>> Mastery Test

106. Evaluate the expressions when $x = 4$ and $y = 7$.
- $x + y$
 - $5y + x$
 - $-(x + y)$
107. Simplify.
- $(4x + 3y) - (x + 2y)$
 - $(5x + 3y) - (7x - 2y)$
108. Simplify.
- $-(-2x + 3y) - 6x$
 - $-(-x^2 - 5y) + x$
109. Combine like terms (simplify).
- $7a - 3a$
 - $5a + 3b - a + 3b$
 - $\frac{2}{9}a + \frac{5}{7}b + \frac{3}{9}a - \frac{4}{7}b$
110. Factor.
- $4a - 8b$
 - $bx + by - bz$
 - $5a - 10b - 15c$
111. Multiply.
- $3(a + 2b)$
 - $5(2a - 3b)$
 - $-4(a - 3b + c)$
112. What are the terms in $-5x^3 + 2x - 3$?

>>> Skill Checker

Write as a product of factors without exponents and multiply.

113. $3^2 \cdot 5^2 \cdot 7^0$

114. $2^3 \cdot 5^2 \cdot 7^1$

115. $10^3 \cdot 3^0 \cdot 5^2 \cdot 8^1$

10.2

The Algebra of Exponents

▶ Objectives

You should be able to:

- A > Write a number with a negative exponent as a fraction and vice versa.
- B > Multiply expressions involving exponents.
- C > Divide expressions involving exponents.
- D > Raise a power to a power.
- E > Solve applications involving the concepts studied.

▶ To Succeed, Review How To . . .

1. Understand the meaning of the word *exponent*. (p. 78)
2. Add, subtract, and multiply numbers. (pp. 577–580)

▶ Getting Started

As we mentioned in Section 1.7, exponential notation is used to indicate how many times a quantity is to be used as a *factor*. For example, the area A of the square in the figure can be written as

$$A = x \cdot x = x^2 \quad \text{Read "x squared" or "x to the second power."}$$

The exponent 2 indicates that the x is used as a factor *twice*. Similarly, the volume V of the cube is

$$V = x \cdot x \cdot x = x^3 \quad \text{Read "x cubed" or "x to the third power."}$$

This time, the exponent 3 indicates that the x is used as a factor *three* times.

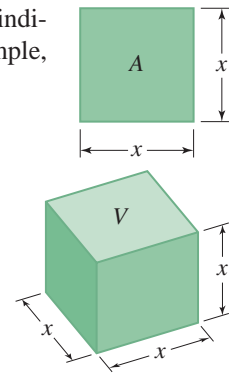

A > Integer Exponents

If a symbol x (called the *base*) is to be used n times as a factor, we use the following definition:

EXPONENT

$$\underbrace{x \cdot x \cdot x \cdot \dots \cdot x}_{n \text{ factors}} = x^n \quad \begin{array}{l} \leftarrow \text{exponent} \\ \uparrow \\ \text{base} \end{array}$$

Sometimes x^n is called a **power** of x , or x to the n th power. Note that if the base carries no exponent, the exponent is assumed to be 1; that is,

$$a = a^1, b = b^1, \text{ and } c = c^1.$$

We can use integers as exponents. Look at the pattern obtained by dividing by 10 in each step.

$$10^3 = 1000$$

$$10^2 = 100$$

$$10^1 = 10$$

$$10^0 = 1$$

Note that the exponents decrease by 1 at each step.

As you can see, this procedure yields $10^0 = 1$. In general, we make the following definition.

ZERO EXPONENT

Any nonzero number raised to the 0 power is 1.

$$x^0 = 1, \quad x \neq 0$$

FOLLOW THE PATTERN!

$$10^{-1} = \frac{1}{10} = \frac{1}{10^1}$$

$$10^{-2} = \frac{1}{100} = \frac{1}{10^2}$$

$$10^{-3} = \frac{1}{1000} = \frac{1}{10^3}$$

Now look at the numbers in the box above. Note that we obtained

$$10^{-1} = \frac{1}{10}, \quad 10^{-2} = \frac{1}{10^2}, \quad \text{and} \quad 10^{-3} = \frac{1}{10^3}$$

Thus, we make the following definition:

NEGATIVE EXPONENT

If n is a positive integer, any nonzero number x raised to the $-n$ power is the reciprocal of x^n .

$$x^{-n} = \frac{1}{x^n}, \quad x \neq 0$$

In general, negative exponents should *not* be included in the final answer (except for scientific notation), so this definition helps you to simplify them. Since $x^n \cdot x^{-n} = x^n \cdot \frac{1}{x^n} = \frac{x^n}{x^n} = 1$, x^{-n} and x^n are reciprocals.

The definition of the negative exponent $-n$ means that

$$6^{-2} = \frac{1}{6^2} = \frac{1}{6 \cdot 6} = \frac{1}{36}$$

$$2^{-3} = \frac{1}{2^3} = \frac{1}{2 \cdot 2 \cdot 2} = \frac{1}{8}$$

$$\frac{1}{4^2} = 4^{-2}$$

$$\frac{1}{3^4} = 3^{-4}$$

EXAMPLE 1 Simplifying negative exponents

Write as a fraction and simplify.

a. 6^{-2}

b. 4^{-3}

SOLUTION 1

a. $6^{-2} = \frac{1}{6^2} = \frac{1}{6 \cdot 6} = \frac{1}{36}$

b. $4^{-3} = \frac{1}{4^3} = \frac{1}{4 \cdot 4 \cdot 4} = \frac{1}{64}$

PROBLEM 1

Write as a fraction and simplify.

a. 5^{-2}

b. 3^{-3}

EXAMPLE 2

Write using negative exponents.

a. $\frac{1}{5^4}$

b. $\frac{1}{7^5}$

SOLUTION 2

a. Using the definition, we have $\frac{1}{5^4} = 5^{-4}$.

b. $\frac{1}{7^5} = 7^{-5}$

PROBLEM 2

Write using negative exponents.

a. $\frac{1}{7^4}$

b. $\frac{1}{6^5}$

Answers to PROBLEMS

1. a. $\frac{1}{25}$ b. $\frac{1}{27}$ 2. a. 7^{-4} b. 6^{-5}

B > Multiplying Exponential Expressions

We are now ready to multiply expressions involving exponents. For example, to multiply x^2 by x^3 , we first write

$$\begin{aligned} & x^2 \cdot x^3 \\ &= \underbrace{x \cdot x}_{x^2} \cdot \underbrace{x \cdot x \cdot x}_{x^3} \\ &= x^{2+3} \\ &= x^5 \end{aligned}$$

Clearly, we have simply *added* the exponents of x^2 and x^3 to find the exponent of the result. Similarly,

$$\begin{aligned} a^3 \cdot a^4 &= a^{3+4} = a^7 \\ b^2 \cdot b^4 &= b^{2+4} = b^6 \end{aligned}$$

What about multiplying x^5 by x^{-2} ? We have:

$$\begin{aligned} x^5 \cdot x^{-2} &= (x \cdot x \cdot x \cdot x \cdot x) \cdot \left(\frac{1}{x \cdot x}\right) \\ &= x \cdot x \cdot x \cdot \left(\frac{x \cdot x}{1}\right) \cdot \left(\frac{1}{x \cdot x}\right) = x \cdot x \cdot x \cdot \frac{x \cdot x}{x \cdot x} = x^3 \end{aligned}$$

Adding exponents gives

$$x^5 \cdot x^{-2} = x^{5+(-2)} = x^3 \quad \text{Same answer!}$$

Similarly,

$$x^{-3} \cdot x^{-2} = \frac{1}{x^3} \cdot \frac{1}{x^2} = \frac{1}{x^{3+2}} = \frac{1}{x^5} = x^{-5}$$

Adding exponents gives

$$x^{-3} \cdot x^{-2} = x^{-3+(-2)} = x^{-5} \quad \text{Same answer again!}$$

We state the resulting rule here for your convenience.

THE PRODUCT RULE OF EXPONENTS

For any nonzero number x and any integers m and n ,

$$x^m \cdot x^n = x^{m+n}, \quad x \neq 0$$

This rule states that when *multiplying* exponential expressions with the *same* base, *add* the exponents.

EXAMPLE 3 Multiplying exponential expressions

Multiply and simplify.

- a. $2^6 \cdot 2^2$ b. $x^3 \cdot x^4$ c. $4^3 \cdot 4^{-5}$
 d. $y^2 \cdot y^{-3}$ e. $a^{-5} \cdot a^5$

SOLUTION 3

- a. $2^6 \cdot 2^2 = 2^{6+2} = 2^8 = 256$
 b. $x^3 \cdot x^4 = x^{3+4} = x^7$
 c. $4^3 \cdot 4^{-5} = 4^{3+(-5)} = 4^{-2} = \frac{1}{4^2} = \frac{1}{16}$

Note that we wrote the answer **without** using negative exponents.

- d. $y^2 \cdot y^{-3} = y^{2+(-3)} = y^{-1} = \frac{1}{y}$
 Again, we wrote the answer without negative exponents.
 e. $a^{-5} \cdot a^5 = a^{-5+5} = a^0 = 1$

PROBLEM 3

Multiply and simplify.

- a. $2^5 \cdot 2^{-3}$ b. $x^5 \cdot x^3$
 c. $3^4 \cdot 3^{-7}$ d. $x^3 \cdot x^{-4}$
 e. $y^3 \cdot y^{-3}$

Answers to PROBLEMS

3. a. 4 b. x^8 c. $\frac{1}{27}$ d. $\frac{1}{x}$ e. 1

C > Dividing Exponential Expressions

To divide expressions involving exponents, we need to develop a rule to handle these exponents. For example, to divide x^5 by x^3 , we first write

$$\frac{x^5}{x^3} = \frac{x \cdot x \cdot x \cdot x \cdot x}{x \cdot x \cdot x}, \quad x \neq 0$$

Since $(x \cdot x \cdot x)$ is common to the numerator and denominator, we have

$$\frac{x^5}{x^3} = \frac{\mathbf{(x \cdot x \cdot x)} \cdot x \cdot x}{\mathbf{(x \cdot x \cdot x)}} = x^{5-3} = x \cdot x = x^2$$

Here the bold x 's mean that we divided the numerator and denominator by the common factor $(x \cdot x \cdot x)$. Of course, you can immediately see that the exponent 2 in the answer is simply the *difference* of the original two exponents, that is,

$$\frac{x^5}{x^3} = x^{5-3} = x^2$$

Similarly,

$$\frac{x^7}{x^4} = x^{7-4} = x^3$$

$$\frac{y^4}{y} = y^{4-1} = y^3$$

The rule used can be extended to any integers.

THE QUOTIENT RULE OF EXPONENTS

For any nonzero number x and any integers m and n ,

$$\frac{x^m}{x^n} = x^{m-n}, \quad x \neq 0$$

This rule states that when *dividing* exponential expressions with the *same base*, *subtract* the exponents.

Thus,

$$\frac{2^4}{2^{-1}} = 2^{4-(-1)} = 2^{4+1} = 2^5 = 32$$

$$\frac{x^3}{x^5} = x^{3-5} = x^{-2} = \frac{1}{x^2}$$

(We write the answer without negative exponents.)

EXAMPLE 4 Dividing exponential expressions

Divide and simplify.

a. $\frac{6^3}{6^{-2}}$ b. $\frac{x}{x^5}$ c. $\frac{y^{-2}}{y^{-2}}$ d. $\frac{z^{-3}}{z^{-4}}$

SOLUTION 4

a. $\frac{6^3}{6^{-2}} = 6^{3-(-2)} = 6^{3+2} = 6^5 = 7776$

b. $\frac{x}{x^5} = x^{1-5} = x^{-4} = \frac{1}{x^4}$

c. $\frac{y^{-2}}{y^{-2}} = y^{-2-(-2)} = y^{-2+2} = y^0 = 1$

d. $\frac{z^{-3}}{z^{-4}} = z^{-3-(-4)} = z^{-3+4} = z^1 = z$

PROBLEM 4

Divide and simplify.

a. $\frac{7^2}{7^{-3}}$ b. $\frac{y}{y^6}$

c. $\frac{x^{-3}}{x^{-3}}$ d. $\frac{z^{-4}}{z^{-5}}$

D > Raising a Power to a Power

Suppose we wish to find $(5^3)^2$. By definition,

$$(5^3)^2 = 5^3 \cdot 5^3 = 5^{3+3}, \quad \text{or} \quad 5^6$$

Answers to PROBLEMS

4. a. $7^5 = 16,807$ b. $\frac{1}{y^5}$ c. 1 d. z

We could get this answer by multiplying exponents in $(5^3)^2$, obtaining $5^{3 \cdot 2} = 5^6$. Similarly,

$$(4^{-2})^3 = \frac{1}{4^2} \cdot \frac{1}{4^2} \cdot \frac{1}{4^2} = \frac{1}{4^6} = 4^{-6}$$

Again, we could have multiplied exponents in $(4^{-2})^3$, obtaining $4^{-2 \cdot 3} = 4^{-6}$. We use these ideas to state the following rule.

THE POWER RULE OF EXPONENTS

For any nonzero number x and any integers m and n ,

$$(x^m)^n = x^{mn}, \quad x \neq 0$$

This rule states that when raising an exponential expression to a *power*, *multiply* the exponents.

EXAMPLE 5 Raising a power to a power

Simplify.

- a. $(2^3)^2$ b. $(x^{-2})^3$ c. $(y^4)^{-5}$ d. $(z^{-2})^{-3}$

SOLUTION 5

- a. $(2^3)^2 = 2^{3 \cdot 2} = 2^6 = 64$ b. $(x^{-2})^3 = x^{-2 \cdot 3} = x^{-6} = \frac{1}{x^6}$
 c. $(y^4)^{-5} = y^{4(-5)} = y^{-20} = \frac{1}{y^{20}}$ d. $(z^{-2})^{-3} = z^{-2(-3)} = z^6$

PROBLEM 5

Simplify.

- a. $(5^3)^2$ b. $(x^{-3})^4$
 c. $(y^3)^{-6}$ d. $(z^{-3})^{-5}$

Sometimes we need to raise several factors inside parentheses to a power, as in $(x^2y^3)^3$. We use the definition of cubing and write

$$\begin{aligned} (x^2y^3)^3 &= x^2y^3 \cdot x^2y^3 \cdot x^2y^3 \\ &= (x^2 \cdot x^2 \cdot x^2)(y^3 \cdot y^3 \cdot y^3) \\ &= (x^2)^3(y^3)^3 \\ &= x^6y^9 \end{aligned}$$

We could get the same answer by multiplying each of the exponents in x^2y^3 by 3, obtaining $x^{2 \cdot 3}y^{3 \cdot 3} = x^6y^9$.

Thus, to raise several factors inside parentheses to a power, we raise each factor to the given power, as shown next.

THE PRODUCT TO A POWER RULE OF EXPONENTS

For any real numbers x and y and any integers m , n , and k ,

$$(x^m y^n)^k = (x^m)^k (y^n)^k = x^{mk} y^{nk}$$

This rule states that when raising *several factors* inside parentheses to a *power*, raise each factor to the given *power*.

EXAMPLE 6 Raising a product to a power

Simplify.

- a. $(x^2y^{-2})^3$ b. $(x^{-2}y^3)^3$ c. $(x^{-2}y^3)^{-2}$

SOLUTION 6

- a. $(x^2y^{-2})^3 = (x^2)^3(y^{-2})^3$
 $= x^6y^{-6}$
 $= \frac{x^6}{y^6}$

PROBLEM 6

Simplify.

- a. $(x^3y^{-2})^3$
 b. $(x^{-3}y^2)^3$
 c. $(x^3y^2)^{-2}$

(continued)

Answers to PROBLEMS

5. a. $5^6 = 15,625$ b. $\frac{1}{x^{12}}$ c. $\frac{1}{y^{18}}$ d. z^{15} 6. a. $\frac{x^9}{y^6}$ b. $\frac{y^6}{x^9}$ c. $\frac{1}{x^6y^4}$

$$\begin{aligned} \text{b. } (x^{-2}y^3)^3 &= (x^{-2})^3(y^3)^3 \\ &= x^{-6}y^9 \\ &= \frac{y^9}{x^6} \end{aligned}$$

$$\begin{aligned} \text{c. } (x^{-2}y^3)^{-2} &= (x^{-2})^{-2}(y^3)^{-2} \\ &= x^4y^{-6} \\ &= \frac{x^4}{y^6} \end{aligned}$$

E > Applications: Compound Interest

Suppose you invest P dollars at 10% compounded annually. At the end of 1 year you will have your original principal P plus the interest, $10\% \cdot P$, that is, $P + 0.10P = (1 + 0.10)P = 1.10P$. At the end of 2 years, you will have $1.10P$ plus the interest earned on $1.10P$, that is, $1.10P + 0.10(1.10P) = 1.10P(1 + 0.10) = 1.10P(1.10)$, or $(1.10)^2P$. If you follow this pattern, at the end of 3 years you will have $(1.10)^3P$, and so on. Here is the general formula:

COMPOUND INTEREST

If the principal P is invested at rate r , compounded annually, in n years the compound amount A will be

$$A = P(1 + r)^n$$

EXAMPLE 7 Calculating a compounded amount

If \$1000 is invested at 10% compounded annually, how much will be in the account at the end of 3 years?

SOLUTION 7 Here $P = \$1000$, $r = 10\% = 0.10$, and $n = 3$. We have

$$\begin{aligned} A &= 1000(1 + 0.10)^3 \\ &= 1000(1.10)^3 = 1000(1.331) = \$1331 \end{aligned}$$

PROBLEM 7

If \$500 is invested at 10% compounded annually, how much will be in the account at the end of 2 years?

GREEN MATH

EXAMPLE 8 Garbage produced per person in a year

According to the Environmental Protection Agency, each person in the United States produces about (1.5×10^3) pounds of garbage each year. If there are (3×10^8) persons in the United States, how many pounds of garbage is that?

SOLUTION 8 Since there are (3×10^8) persons each producing (1.5×10^3) pounds the total amount is $(3 \times 10^8) \times (1.5 \times 10^3) = (3 \times 1.5) \times (10^8 \times 10^3)$

$$\begin{aligned} &= 4.5 \times 10^{8+3} \\ &= 4.5 \times 10^{11} \text{ pounds} \end{aligned}$$

This is 450,000,000,000 or 450 billion pounds of garbage.

PROBLEM 8

The population of Canada is about (3.3×10^7) persons. According to Statistics Canada, each of these persons produces almost 700 kg of garbage a year or about (1.5×10^3) pounds per year. How many pounds of garbage are produced in Canada every year?

Answers to PROBLEMS

7. \$605 8. $4.95 \times 10^{10} = 49,500,000,000$ pounds



Calculator Corner

If you have a scientific calculator with a y^x key (some students call y^x the power key), the numerical calculations in this section become simple. For example, here is the way to find 5^3 : Press **5** y^x **3** **ENTER**. The answer, 125, will be displayed. Similarly, to find 6^{-2} : Press **6** y^x **2** \pm **ENTER**. Note that you *do not* enter -2 , but enter 2 and \pm , which will change the sign of 2 to -2 . The answer is given as a decimal.

> Exercises 10.2



> Practice Problems > Self-Tests
> Media-rich eBooks > e-Professors > Videos

< A > Integer Exponents In Problems 1–6, write as a fraction and simplify.

- | | | | | | |
|----------------|----------------|----------------|----------------|----------------|----------------|
| 1. a. 4^{-2} | 2. a. 2^{-3} | 3. a. 5^{-3} | 4. a. 7^{-2} | 5. a. 3^{-4} | 6. a. 6^{-3} |
| b. x^{-2} | b. x^{-3} | b. y^{-3} | b. y^{-2} | b. z^{-4} | b. a^{-3} |

In Problems 7–12, write using negative exponents.

- | | | | | | |
|-----------------------|-----------------------|-----------------------|------------------------|------------------------|------------------------|
| 7. a. $\frac{1}{2^3}$ | 8. a. $\frac{1}{3^4}$ | 9. a. $\frac{1}{4^5}$ | 10. a. $\frac{1}{5^6}$ | 11. a. $\frac{1}{3^5}$ | 12. a. $\frac{1}{7^4}$ |
| b. $\frac{1}{x^3}$ | b. $\frac{1}{x^4}$ | b. $\frac{1}{y^5}$ | b. $\frac{1}{y^6}$ | b. $\frac{1}{z^5}$ | b. $\frac{1}{z^4}$ |

< B > Multiplying Exponential Expressions In Problems 13–36, multiply and simplify.

- | | | | |
|------------------------------|------------------------------|------------------------------|------------------------------|
| 13. a. $3^2 \cdot 3^3$ | 14. a. $4^2 \cdot 4^2$ | 15. a. $2^{-5} \cdot 2^7$ | 16. a. $3^8 \cdot 3^{-5}$ |
| b. $x^5 \cdot x^8$ | b. $x^2 \cdot x^2$ | b. $y^{-3} \cdot y^8$ | b. $y^7 \cdot y^{-3}$ |
| 17. a. $4^{-6} \cdot 4^4$ | 18. a. $5^{-4} \cdot 5^2$ | 19. a. $6^{-1} \cdot 6^{-2}$ | 20. a. $3^{-2} \cdot 3^{-1}$ |
| b. $x^{-7} \cdot x^3$ | b. $x^{-5} \cdot x^2$ | b. $y^{-3} \cdot y^{-4}$ | b. $y^{-8} \cdot y^{-4}$ |
| 21. a. $2^{-4} \cdot 2^{-2}$ | 22. a. $4^{-1} \cdot 4^{-2}$ | 23. $x^6 \cdot x^{-4}$ | 24. $y^7 \cdot y^{-2}$ |
| b. $x^{-3} \cdot x^{-7}$ | b. $x^{-2} \cdot x^{-6}$ | | |
| 25. $y^{-3} \cdot y^5$ | 26. $x^{-7} \cdot x^8$ | 27. $a^3 \cdot a^{-8}$ | 28. $b^4 \cdot b^{-7}$ |
| 29. $x^{-5} \cdot x^3$ | 30. $y^{-6} \cdot y^2$ | 31. $x \cdot x^{-3}$ | 32. $y \cdot y^{-5}$ |
| 33. $a^{-2} \cdot a^{-3}$ | 34. $b^{-5} \cdot b^{-2}$ | 35. $b^{-3} \cdot b^3$ | 36. $a^6 \cdot a^{-6}$ |

< C > Dividing Exponential Expressions In Problems 37–50, divide and simplify.

- | | | | | | | |
|--------------------------|-----------------------------|-----------------------------|--------------------------|--------------------------|-----------------------------|-----------------------------|
| 37. $\frac{3^4}{3^{-1}}$ | 38. $\frac{2^2}{2^{-2}}$ | 39. $\frac{4^{-1}}{4^2}$ | 40. $\frac{3^{-2}}{3^3}$ | 41. $\frac{y}{y^3}$ | 42. $\frac{x}{x^4}$ | 43. $\frac{x}{x^{-2}}$ |
| 44. $\frac{y}{y^{-3}}$ | 45. $\frac{x^{-3}}{x^{-1}}$ | 46. $\frac{x^{-4}}{x^{-2}}$ | 47. $\frac{x^{-3}}{x^4}$ | 48. $\frac{y^{-4}}{y^5}$ | 49. $\frac{x^{-2}}{x^{-5}}$ | 50. $\frac{y^{-3}}{y^{-6}}$ |

< D > Raising a Power to a Power In Problems 51–74, simplify.

- | | | | | | |
|---------------------|---------------------|------------------------|------------------------|---------------------------|---------------------------|
| 51. $(3^2)^2$ | 52. $(2^3)^2$ | 53. $(3^{-1})^2$ | 54. $(2^{-2})^2$ | 55. $(2^{-2})^{-3}$ | 56. $(3^{-1})^{-2}$ |
| 57. $(3^2)^{-1}$ | 58. $(2^3)^{-2}$ | 59. $(x^3)^{-3}$ | 60. $(y^2)^{-4}$ | 61. $(y^{-3})^2$ | 62. $(x^{-4})^3$ |
| 63. $(a^{-2})^{-3}$ | 64. $(b^{-3})^{-5}$ | 65. $(x^3y^{-2})^3$ | 66. $(x^2y^{-3})^2$ | 67. $(x^{-2}y^3)^2$ | 68. $(x^{-4}y^4)^3$ |
| 69. $(x^3y^2)^{-3}$ | 70. $(x^5y^4)^{-4}$ | 71. $(x^{-6}y^{-3})^2$ | 72. $(y^{-4}z^{-3})^5$ | 73. $(x^{-4}y^{-4})^{-3}$ | 74. $(y^{-5}z^{-3})^{-4}$ |

< E > Applications: Compound Interest Round to the nearest cent.

- 75. Investment problem** If \$1000 is invested at 8% compounded annually, how much will be in the account at the end of 3 years?
- 76. Investment problem** If \$500 is invested at 10% compounded annually, how much will be in the account at the end of 3 years?
- 77. Investment problem** Suppose \$1000 is invested at 10% compounded annually. How much will be in the account at the end of 4 years?

>>> Applications: Green Math

Garbage champions Quick, which three nations produce the most garbage per capita? Look at the graph! Both Ireland and Norway each produce about 800 kg per person which is equivalent to 1.8×10^3 pounds per person!

- 78.** If the population of Norway is 4.7×10^6 , how many pounds of garbage are produced in Norway every year?
- 79.** If the population of Ireland is 4.2×10^6 , how many pounds of garbage are produced in Ireland every year?

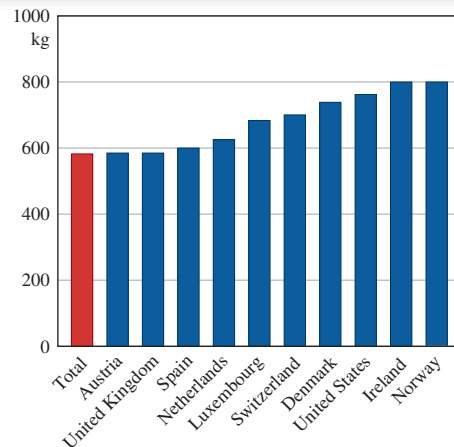

Source: OECD Factbook 2009.

>>> Applications

- 80. Petroleum and gas reserves** The estimated petroleum and gas reserves for the United States are about 2.8×10^{17} kilocalories. If we consume these reserves at the rate of 1.4×10^{16} kilocalories per year, they will last $\frac{2.8 \times 10^{17}}{1.4 \times 10^{16}}$, or $\frac{2.8}{1.4} \times \frac{10^{17}}{10^{16}}$ years. How many years is that?
- 81. Internet sites** In a recent year almost 3×10^7 people visited flower, greeting, and gift sites on the Internet. On average, each visitor spent about \$9 from January 1 to February 9 on these sites. How many million dollars were spent on flowers, greetings, and gift sites during this period?
- Source: clickz.com; http://www.clickz.com/stats/sectors/traffic_patterns/article.php/3585186#table2.
- 82. Travel expenses** A global panel of 2×10^6 people spent about $\$3.1 \times 10^4$ annually on travel expenses. What was the total amount spent during the year?
- Source: clickz.com; <http://www.clickz.com/stats/sectors/retailing/article.php/3575456#table1>.
- 83. U.S. national debt** At the present time, the U.S. national debt amounts to $\$11.7 \times 10^{12}$. Since the population of the United States is approximately $3 \cdot 10^8$, the share of each person amounts to $\frac{\$11.7 \times 10^{12}}{3 \times 10^8}$. How much is that?
- 84. U.S. national debt** If the U.S. national debt is rounded to $\$11.7 \cdot 10^{12}$, the average monthly increase on the debt is $\frac{\$11.7 \times 10^{12}}{1.2 \times 10}$. How many billions per month is that?

>>> Using Your Knowledge

Patterns There are many interesting patterns involving exponents. Use your knowledge to find the answers to the following problems.

- 85.** $1^2 = 1$
 $(11)^2 = 121$
 $(111)^2 = 12,321$
 $(1111)^2 = 1,234,321$
a. Find $(11,111)^2$.
b. Find $(111,111)^2$.
- 86.** $1^2 = 1$
 $2^2 = 1 + 2 + 1$
 $3^2 = 1 + 2 + 3 + 2 + 1$
 $4^2 = 1 + 2 + 3 + 4 + 3 + 2 + 1$
a. Use this pattern to write 5^2 .
b. Use this pattern to write 6^2 .

87. $1 + 3 = 2^2$
 $1 + 3 + 5 = 3^2$
 $1 + 3 + 5 + 7 = 4^2$
 a. Find $1 + 3 + 5 + 7 + 9$.
 b. Find $1 + 3 + 5 + 7 + 9 + 11 + 13$.
88. In this problem, discover your own pattern. What is the largest number you can construct by using the number 9 three times? (It is *not* 999!)

>>> Write On

89. Explain why the product rule does not apply to the expression $x^n \cdot y^n$.
90. Write in your own words the difference between the product rule and the power rule.
91. Write in your own words three different reasons for the fact that $x^0 = 1$ ($x \neq 0$).

>>> Concept Checker

Fill in the blank(s) with the correct word(s), phrase, or mathematical statement.

92. **Exponential notation** is used to indicate how many times a quantity is to be used as a _____.
93. For $x \neq 0$, $x^0 =$ _____.
94. If n is a positive integer, $x^{-n} =$ _____.
95. If m and n are integers, $x^m \cdot x^n =$ _____.
96. If m and n are integers, $\frac{x^m}{x^n} =$ _____.
97. If m and n are integers, $(x^m)^n =$ _____.
98. If m , n , and k are integers, $(x^m \cdot y^n)^k =$ _____.
99. If a principal P is invested at a rate r compounded annually for n years, the compound amount A is _____.

x^{m+n}

$P(1+r)^n$

$x^{m \cdot n}$

factor

x^{m-n}

term

$x^{-m \cdot n}$

1

$P(1+r)^n$

$\frac{1}{x^n}$

$r(1+P)^n$

$x^{m \cdot k} y^{n \cdot k}$

>>> Mastery Test

100. If \$1000 is invested at 4% compounded annually, what will be the compound amount A at the end of 2 years?
101. Simplify.
 a. $(2^2)^3$ b. $(x^{-3})^2$
 c. $(a^3)^{-5}$ d. $(b^{-2})^{-5}$
102. Divide and simplify.
 a. $\frac{3^4}{3^{-2}}$ b. $\frac{a}{a^4}$
 c. $\frac{x^{-4}}{x^{-4}}$ d. $\frac{c^{-4}}{c^{-5}}$
103. Simplify.
 a. $(a^3b^{-2})^4$ b. $(a^{-4}b^4)^3$
 c. $(a^{-3}b^4)^{-2}$
104. Multiply and simplify.
 a. $3^3 \cdot 3^2$ b. $a^3 \cdot a^4$
 c. $3^4 \cdot 3^{-5}$ d. $a^4 \cdot a^{-5}$
 e. $a^{-7} \cdot a^7$
105. Write using negative exponents.
 a. $\frac{1}{6^3}$ b. $\frac{1}{c^4}$
106. Write as a fraction and simplify.
 a. 3^{-2} b. 4^{-3}

>>> Skill Checker

107. Find 7.31×10^1 . 108. Find 7.31×10^2 . 109. Find 7.31×10^4 . 110. Find 7.31×10^5 .

10.3

Scientific Notation

▶ Objectives

You should be able to:

- A** > Convert between ordinary decimal notation and scientific notation.
- B** > Multiply and divide numbers in scientific notation.
- C** > Solve applications involving the concepts studied.

▶ To Succeed, Review How To . . .

1. Multiply and divide a number by a power of 10 (10, 100, 1000, etc.). (pp. 55–56, 223–224, 227–228)
2. Use the properties of exponents. (pp. 78, 83–85)

▶ Getting Started

How many facts do you know about the sun? Here is some information taken from an encyclopedia article.

Mass: 2.19×10^{27} tons
 Temperature: 1.8×10^6 degrees Fahrenheit
 Energy per minute: 2.4×10^4 hp

Each number involved is written as a *product* of a number between 1 and 10 and an appropriate power of 10. This form is called **scientific notation**, which we use to write numbers that are either very large or very small.



A > Scientific Notation

SCIENTIFIC NOTATION

A number in scientific notation is written as

$$M \times 10^n \quad \begin{array}{l} M = \text{a number between 1 and 10} \\ n = \text{an integer} \end{array}$$

How do we change a whole number to scientific notation? First, recall that when we *multiply* a number by a power of 10 ($10^1 = 10$, $10^2 = 100$, and so on) we simply *move* the decimal point as many places to the *right* as indicated by the *exponent* of 10. Thus,

$$7.31 \times 10^1 = 73.1 \quad (\text{Exponent 1, move 1 place right.})$$

$$72.813 \times 10^2 = 7281.3 \quad (\text{Exponent 2, move 2 places right.})$$

$$160.7234 \times 10^3 = 160723.4 \quad (\text{Exponent 3, move 3 places right.})$$

On the other hand, if we *divide* a number by a power of 10, we move the decimal point as many places to the *left* as indicated by the exponent of 10. Thus,

$$\frac{7}{10} = 0.7 = 7 \times 10^{-1}$$

$$\frac{8}{100} = 0.08 = 8 \times 10^{-2}$$

and

$$\frac{4.7}{10,000} = 00.00047 = 4.7 \times 10^{-4}$$

TO WRITE A NUMBER IN SCIENTIFIC NOTATION ($M \times 10^n$)

1. Move the decimal point in the given number so that there is only one digit to its left. The resulting number is M .
2. Count how many places you moved the decimal point in step 1. If the decimal point was moved to the *left*, n is *positive*; if it was moved to the *right*, n is *negative*.
3. Write $M \times 10^n$.

Note that when the given number is **greater** than 1 the exponent is positive; if the number is **less** than 1 the exponent is negative.

For example,

$5.3 = 5.3 \times 10^0$	The decimal point in 5.3 must be moved 0 places.
$87 = 8.7 \times 10^1 = 8.7 \times 10$	The decimal point in 87 must be moved 1 place to the left to get 8.7.
$68,000 = 6.8 \times 10^4$	The decimal point in 68,000 must be moved 4 places to the left to get 6.8.
$0.49 = 4.9 \times 10^{-1}$	The decimal point in 0.49 must be moved 1 place to the right to get 4.9.
$0.072 = 7.2 \times 10^{-2}$	The decimal point in 0.072 must be moved 2 places to the right to get 7.2.

Note that if the standard notation of a number (like 68,000) is large (greater than 1) the exponent of 10 in scientific notation is *positive*. If the standard notation of a number (like 0.072) is small (smaller than 1) the exponent of 10 is *negative*.

EXAMPLE 1 Writing a number in scientific notation

The approximate distance to the sun is 93,000,000 miles and the wavelength of its ultraviolet light is 0.000035 centimeters. Write 93,000,000 and 0.000035 in scientific notation.

SOLUTION 1

$$93,000,000 = 9.3 \times 10^7$$

$$0.000035 = 3.5 \times 10^{-5}$$

PROBLEM 1

The distance to the moon is about 239,000 miles and its mass is 0.0123456 times that of the earth. Write 239,000 and 0.0123456 in scientific notation.

EXAMPLE 2 Writing a number in standard notation

A jumbo jet weighs 7.75×10^5 pounds, whereas a house spider weighs 2.2×10^{-4} pounds. Write 7.75×10^5 and 2.2×10^{-4} in standard notation.

SOLUTION 2

$$7.75 \times 10^5 = 775,000$$

$$2.2 \times 10^{-4} = 0.00022$$

PROBLEM 2

The Concorde at the Smithsonian Air and Space Museum weighs 4.08×10^5 pounds and a cricket weighs 3.125×10^{-4} pounds. Write 4.08×10^5 and 3.125×10^{-4} in standard notation.

B > Multiplying and Dividing Using Scientific Notation

Consider the product $300 \cdot 2000 = 600,000$. In scientific notation, we would write

$$(3 \times 10^2) \cdot (2 \times 10^3) = 6 \times 10^5$$

To find the answer, we can multiply 3 by 2 to obtain 6 and 10^2 by 10^3 , obtaining 10^5 . To multiply numbers in scientific notation, we proceed in a similar manner:

1. Multiply the decimal parts first and write the result in scientific notation.
2. Multiply the powers of 10.
3. The answer, which should be simplified, is the product of steps 1 and 2.

Answers to PROBLEMS

1. 2.39×10^5 ; 1.23456×10^{-2}
2. 408,000; 0.0003125

EXAMPLE 3 Multiplying numbers in scientific notation

Multiply.

a. $(5 \times 10^3) \times (8.1 \times 10^4)$ b. $(3.2 \times 10^2) \times (4 \times 10^{-5})$

SOLUTION 3

a. We multiply the decimal parts first.

$$5 \times 8.1 = 40.5 = 4.05 \times 10$$

Then multiply the powers of 10.

$$10^3 \times 10^4 = 10^7 \quad (\text{adding exponents})$$

The answer is $(4.05 \times 10) \times 10^7$, or 4.05×10^8 .

b. Multiply the decimals.

$$3.2 \times 4 = 12.8 = 1.28 \times 10$$

Multiply the powers of 10.

$$10^2 \times 10^{-5} = 10^{2-5} = 10^{-3}$$

The answer is $(1.28 \times 10) \times 10^{-3}$, or $1.28 \times 10^{1+(-3)} = 1.28 \times 10^{-2}$.**PROBLEM 3**

Multiply.

a. $(6 \times 10^4) \times (2.2 \times 10^3)$

b. $(4.1 \times 10^2) \times (3 \times 10^{-5})$

Division is done in the same manner. For example, $\frac{3.2 \times 10^5}{1.6 \times 10^2}$ is found by dividing 3.2 by 1.6 (yielding 2) and 10^5 by 10^2 , which gives 10^3 . The answer is 2×10^3 .

EXAMPLE 4 Dividing numbers in scientific notationDivide: $(1.24 \times 10^{-2}) \div (3.1 \times 10^{-3})$.**SOLUTION 4** First divide 1.24 by 3.1, obtaining $0.4 = 4 \times 10^{-1}$.

Now divide powers of 10:

$$10^{-2} \div 10^{-3} = 10^{-2-(-3)} = 10^{-2+3} = 10^1$$

The answer is $(4 \times 10^{-1}) \times 10^1 = 4 \times 10^0$ or 4.**PROBLEM 4**

Divide.

$$(2.52 \times 10^{-2}) \div (4.2 \times 10^{-3})$$

C > Applications Involving Scientific Notation**GREEN MATH****EXAMPLE 5** Water, water everywhere: sold and recycled

According to ABC News, 36 billion bottles of water were sold in a recent year.

How many bottles of water per person (300 million Americans) is that?

Source: <http://tinyurl.com/vcwpy5>.**SOLUTION 5** We need to find:

$$\begin{aligned} \frac{\text{bottles}}{\text{Americans}} &= \frac{36 \text{ billion}}{300 \text{ million}} \\ &= \frac{(3.6 \times 10) \times (10^9)}{(3 \times 10^2) \times (10^6)} = \frac{3.6 \times 10^{10}}{3 \times 10^8} \end{aligned}$$

Now, $\frac{3.6}{3} = 1.2 = 1.2$ and $\frac{10^{10}}{10^8} = 10^{10-8} = 10^2$, so

$$\frac{3.6 \times 10^{10}}{3 \times 10^8} = 1.2 \times 10^2 = 120$$

This means that 120 bottles of water per person were sold in the United States.

PROBLEM 5

7.2×10^9 of these bottles were recycled. If there are 3×10^8 Americans, how many bottles did each American recycle?

Answers to PROBLEMS

3. a. 1.32×10^8 b. 1.23×10^{-2} 4. 6×10^0 or 6 5. Just 24! Only $\frac{1}{5}$ of the 120 bottles total.



Calculator Corner

If you have a scientific calculator and you multiply 9,800,000 by 4,500,000, the display will show: 4.41 13
This means that the answer is 4.41×10^{13} .

- The display on a calculator shows: 3.34 5
Write this number in scientific notation.
- The display on a calculator shows: -9.97 -6
Write this number in scientific notation.

To enter large or small numbers in a calculator with scientific notation, you must first write the number using scientific notation. Thus, to enter the number 8,700,000,000 in the calculator you must know that 8,700,000,000 is 8.7×10^9 ; then you can key in **8** **.** **7** **[EE]** **9**

The calculator displays: 8.7 09

- What would the display read when you enter the number 73,000,000,000?
- What would the display read when you enter the number 0.000000123?

> Exercises 10.3



> Practice Problems > Self-Tests
> Media-rich eBooks > e-Professors > Videos

< **A** > **Scientific Notation** In Problems 1–10, write in scientific notation.

- 68,000,000 (working women in the United States)
- 78,000,000 (working men in the United States)
- 293,000,000 (U.S. population now)
- 281,000,000 (U.S. population in the year 2000)
- 1,900,000,000 (dollars spent on waterbeds and accessories in one year)
- 0.035 (ounces in a gram)
- 0.00024 (probability of four of a kind in poker)
- 0.000005 (the gram-weight of an amoeba)
- 0.00000002 (the gram-weight of one liver cell)
- 0.00000009 (wavelength of an X-ray in centimeters)

In Problems 11–20, write in standard notation.

- 2.35×10^2 (pounds of meat consumed per person per year in the United States)
- 2.87×10^2 (pounds of fresh fruit consumed per person per year in the United States)
- 8×10^6 (bagels eaten per day in the United States)
- 22×10^6 (jobs created in service industries between now and the year 2010)
- 6.8×10^9 (estimated worth of the five wealthiest women)
- 1.68×10^{10} (estimated worth of the five wealthiest men)
- 2.3×10^{-1} (kilowatts per hour used by your TV)
- 4×10^{-2} in. (1 mm)
- 2.5×10^{-4} (thermal conductivity of glass)
- 4×10^{-11} joules (energy released by splitting one uranium atom)

< **B** > **Multiplying and Dividing Using Scientific Notation** In Problems 21–30, perform the indicated operations (give your answer in scientific notation).

- $(3 \times 10^4) \times (5 \times 10^5)$
- $(5 \times 10^2) \times (3.5 \times 10^3)$
- $(6 \times 10^{-3}) \times (5.1 \times 10^6)$
- $(3 \times 10^{-2}) \times (8.2 \times 10^5)$
- $(4 \times 10^{-2}) \times (3.1 \times 10^{-3})$
- $(3.1 \times 10^{-3}) \times (4.2 \times 10^{-2})$
- $\frac{4.2 \times 10^5}{2.1 \times 10^2}$
- $\frac{5 \times 10^6}{2 \times 10^3}$
- $\frac{2.2 \times 10^4}{8.8 \times 10^6}$
- $\frac{2.1 \times 10^3}{8.4 \times 10^5}$

< C > Applications Involving Scientific Notation

- 31. Annual vegetable consumption** The average American eats 160 pounds of vegetables each year. Since there are about 300 million Americans, the number of pounds of vegetables consumed each year should be:

$$(1.6 \times 10^2) \times (3 \times 10^8)$$

- Write this number in scientific notation.
- Write this number in standard notation.

- 33. Garbage per person** America produces 250 million tons of garbage each year. Since a ton is 2000 pounds and there are about 360 days in a year and 300 million Americans, the number of pounds of garbage produced each day of the year for each man, woman, and child in America is:

$$\frac{(2.5 \times 10^8) \times (2 \times 10^3)}{(3 \times 10^8) \times (3.6 \times 10^2)}$$

Write this number in standard notation to two decimal places.

- 32. Average soft drink consumption** The average American drinks 54.2 gallons of soft drinks each year. Since there are about 300 million Americans, the number of gallons of soft drinks consumed each year should be:

$$(5.42 \times 10^1) \times (3 \times 10^8)$$

- Write this number in scientific notation.
- Write this number in standard notation.

>>> Applications: Green Math

Garbage talk

- 34.** How much garbage will we generate annually by the year 2030? According to Waste Age, 300 million tons! The Census Bureau predicts that in the year 2030 there would be 360 million Americans. Follow the procedure of Problem 33 and find the number of pounds of garbage generated each day of the year 2030 for each man, woman, and child in America. Write the answer in standard notation to two decimal places. Do you think the answer is larger than in Exercise 33?
- 35.** Norway generates 4.23 million tons of garbage each year. If the population of Norway is 4.7×10^6 people, a ton is 2×10^3 pounds, and there are about 360 days in a year, the number of pounds of garbage produced each day for each man, woman, and child in Norway is:

$$\frac{(4.23 \times 10^6) \times (2 \times 10^3)}{(4.7 \times 10^6) \times (3.6 \times 10^2)}$$

Write the answer in standard notation.

Is it crowded where you live? How many people per square mile live in your town? The *population density* is a measurement of population per unit area.

- 36. Population density** The population density of New York State is 3.5×10^2 persons per square mile. If all those people live in an area of 5.5×10^3 square miles, this makes the population of New York State $(3.5 \times 10^2) \times (5.5 \times 10^4)$. How many people live in New York State? Write the answer in scientific and in standard notation.
- 37. Population density** The population density of Paris is 9.2×10^3 persons per square mile. If they live in an area of 1.05×10^3 square miles, this makes the population of Paris $(9.2 \times 10^3) \times (1.05 \times 10^3)$. How many people live in Paris? Write the answer in scientific and in standard notation.
- 38. Population density** What about the population in the entire world? The population density of the world is a mere 43 persons per square kilometer. Since the land area of the world is 1.5×10^8 , this means the world population is $(4.3 \times 10) \times (1.5 \times 10^8)$. How many people is that? Write the answer in scientific and in standard notation.
- 39. Population density** One of the most densely populated places on Earth is Macau, in China. Their population density is $\frac{4.68 \times 10^5}{2.6 \times 10 \text{ km}^2}$, which means 4.68×10^5 inhabitants live in an area of 2.6×10 square kilometers. What is the population density of Macau? Write the answer in scientific and in standard notation.
- 40. Population density** Another densely populated place on Earth is Singapore. Their population density is $\frac{4.416 \times 10^6}{6.9 \times 10^2 \text{ km}^2}$, which means 4.416×10^6 inhabitants live in an area of 6.9×10^2 square kilometers. What is the population density of Singapore? Write the answer in scientific and in standard notation.
- 41. Sunlight** Since the sun is 1.5×10^{11} meters from Earth, it takes light traveling at 3×10^8 meters per second $\frac{1.5 \times 10^{11}}{3 \times 10^8}$ seconds to reach the Earth. How many seconds is that? Write the answer in scientific and in standard notation.
- 42. Moon** The moon is about 3.9×10^8 meters from Earth. It takes light traveling at 3×10^8 meters per second $\frac{3.9 \times 10^8}{3 \times 10^8}$ seconds to reach the Earth. How many seconds is that?

Using Your Knowledge

Astronomy

43. Scientific notation is especially useful when very large quantities are involved. For example, in astronomy we find that the speed of light is 299,792,458 meters per second. Write 299,792,458 in scientific notation.
44. Astronomical distances are so large that they are measured in astronomical units (A.U. for short). An astronomical unit is defined as the average separation (distance) of Earth and the sun, that is, 150,000,000 kilometers. Write 150,000,000 in scientific notation.
45. Distances in astronomy are also measured in *parsecs*:
 1 parsec = 2.06×10^5 A.U. Thus
 1 parsec = $(2.06 \times 10^5) \times (1.5 \times 10^8)$ kilometers. Written in scientific notation, how many kilometers is that?
46. Astronomers also measure distances in light-years, the distance light travels in 1 year: 1 light-year = 9.46×10^{12} kilometers. The closest star, Proxima Centauri, is 4.22 light-years away. In scientific notation, rounded to two decimal places, how many kilometers is that?
47. Since 1 parsec = 3.09×10^{13} km (see Problem 45) and 1 light-year = 9.46×10^{12} km, the number of light-years in a parsec is
- $$\frac{3.09 \times 10^{13}}{9.46 \times 10^{12}}$$
- Write this number in standard notation rounded to two decimal places.

Write On

48. Write in your own words the procedure you use to write a number in scientific notation.
49. What are the advantages and disadvantages of writing numbers in scientific notation?

Concept Checker

Fill in the blank(s) with the correct word(s), phrase, or mathematical statement.

50. A number in **scientific notation** is written as _____, where M is a number between 1 and 10 and n is an integer.
51. To write a number in the scientific notation $M \times 10^n$, **move** the decimal point in the number so that there is only **one** digit to its _____; the result is M .

left

$n \times 10^M$

$M \times 10^n$

right

Mastery Test

52. The Earth is approximately 9.3×10^7 miles from the sun, and light travels at a speed of 1.86×10^5 miles per second. Thus, it takes
- $$\frac{9.3 \times 10^7}{1.86 \times 10^5}$$
- seconds for the light from the sun to reach Earth. Written in standard notation, how many seconds is that?
53. Divide 2.48×10^{-2} by 6.2×10^{-4} . Write the answer in standard notation.
54. Multiply and write the answer in standard notation.
- a. $(5 \times 10^2) \times (6.1 \times 10^4)$
 b. $(6.4 \times 10^2) \times (2 \times 10^{-5})$
55. The half-life of uranium 234 is 250,000 years. Write 250,000 in scientific notation.
56. One of the fastest computers in the world, at the Lawrence Livermore National Laboratory, could perform a single calculation in 0.000 000 000 000 26 second. Write this number in scientific notation.
57. The half-life of uranium 238 is 4.5×10^9 years. Write this number in standard notation.
58. The wavelength of ultraviolet light is 3.5×10^{-5} cm. Write this number in standard notation.

Skill Checker

Solve the following equations.

59. $x - 1 = -4$ 60. $x - \frac{1}{4} = \frac{1}{2}$ 61. $x + \frac{3}{5} = \frac{1}{2}$ 62. $x - 0.3 = 0.9$
63. $x + 0.7 = 0.2$ 64. $0.4x = -0.8$ 65. $-0.3x = 0.9$ 66. $-0.4x = -0.8$

10.4

Solving Linear Equations

▶ Objectives

You should be able to:

A > Solve equations using the addition, subtraction, multiplication, or division principle.

B > Solve linear equations using the five-step procedure given in the text.

▶ To Succeed, Review How To . . .

1. Do addition, subtraction, multiplication, and division using rational numbers. (pp. 577–580)
2. Solve equations. (pp. 91–94, 251–252)

▶ Getting Started

Do you know the man in the picture? He is Albert Einstein, who discovered the famous equation $E = mc^2$. In this section we shall study a different type of equation called a *linear* equation. An **equation** is a sentence having a variable in which the verb is *equals* (or an equivalent verb). Here are some equations.

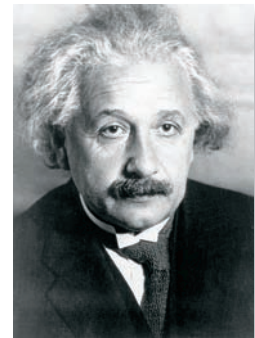

English Language	Algebra
One added to x gives 7.	$x + 1 = 7$
One subtracted from z equals 9.	$z - 1 = 9$
Twice a number n is 8.	$2n = 8$
Half of y is 3.	$\frac{y}{2} = 3$

A > Solving Equations Using the Addition, Subtraction, Multiplication, or Division Principle

The equations shown in the *Getting Started* are also called **linear**, or **first-degree equations**. The variables x , z , n , and y show no exponent, which means that the exponent 1 is *understood* ($x = x^1$, $z = z^1$, $n = n^1$, and $y = y^1$); this is why they are called *first-degree* equations.

We can solve (find the solution of) these equations by using the same principles we studied before.

PRINCIPLES FOR SOLVING EQUATIONS

The equation $a = b$ is equivalent to

$$a + c = b + c \quad (\text{Addition principle})$$

$$a - c = b - c \quad (\text{Subtraction principle})$$

$$a \cdot c = b \cdot c \quad (\text{Multiplication principle, } c \neq 0)$$

$$a \div c = b \div c \quad (\text{Division principle, } c \neq 0)$$

or
$$\frac{a}{c} = \frac{b}{c}$$

Thus, to *solve* an equation, we may add or subtract the same number on *both* sides and multiply or divide *both* sides by the same nonzero number. (Exactly the same operations *must* be done on both sides of the equation to obtain equivalent equations.) The idea is to obtain an equation with the variable (letter) by itself on one side. Let us practice with these principles.

EXAMPLE 1 Solving linear equations

Solve.

a. $x - 1 = -3$ b. $y + \frac{1}{3} = \frac{1}{2}$

SOLUTION 1

a. $x - 1 = -3$ Given.
 $x - 1 + 1 = -3 + 1$ Add 1 to both sides so the x is by itself.
 $x = -2$ Simplify.

CHECK We substitute $x = -2$ in the original equation:

$$\begin{array}{r|l} x - 1 & \stackrel{?}{=} -3 \\ -2 - 1 & -3 \\ \hline -3 & \end{array}$$

Thus, our solution $x = -2$ is correct.

b. $y + \frac{1}{3} = \frac{1}{2}$ Given.
 $y + \frac{1}{3} - \frac{1}{3} = \frac{1}{2} - \frac{1}{3}$ Subtract $\frac{1}{3}$ from both sides to have y by itself.
 $y = \frac{1 \cdot 3}{2 \cdot 3} - \frac{1 \cdot 2}{3 \cdot 2}$ Simplify (we need to use the LCD for $\frac{1}{2}$ and $\frac{1}{3}$,
 $= \frac{3}{6} - \frac{2}{6}$ which is 6, write both fractions with that
 $= \frac{1}{6}$ denominator, and subtract).

CHECK Replacing y with $\frac{1}{6}$ in the original equation,

$$\begin{array}{r|l} y + \frac{1}{3} & \stackrel{?}{=} \frac{1}{2} \\ \frac{1}{6} + \frac{1}{3} & \frac{1}{2} \\ \hline \frac{3}{6} & \\ \frac{1}{2} & \end{array}$$

Thus, our solution $y = \frac{1}{6}$ is correct.

PROBLEM 1

Solve.

a. $x - 6 = -8$
b. $y + \frac{1}{5} = \frac{1}{2}$

EXAMPLE 2 Solving linear equations

Solve.

a. $-x = 6$ b. $\frac{-y}{3} = 4$ c. $-3.2z = 6.4$

SOLUTION 2

a. $-x = 6$ Given.
 $-1x = 6$ Since $-x = -1x$.
 $-1 \cdot (-1x) = -1 \cdot 6$ Multiply both sides by -1 .
 $x = -6$ Simplify ($-1 \cdot (-1x) = 1x = x$).

PROBLEM 2

Solve.

a. $-x = 8$ b. $\frac{-y}{4} = 6$
c. $-1.2z = 4.8$

(continued)

Answers to PROBLEMS

1. a. $x = -2$ b. $y = \frac{3}{10}$
2. a. $x = -8$ b. $y = -24$
c. $z = -4$

CHECK Replace x with -6 in the equation.

$$\begin{array}{r} -x \stackrel{?}{=} 6 \\ -(-6) \bigg| 6 \\ \hline 6 \end{array}$$

Hence, $x = -6$ is the correct solution.

Note that the equation $-1x = 6$ can also be solved by dividing both sides by -1 (using the division principle). The answer is still $x = -6$.

b. $\frac{-y}{3} = 4$ Given.

$$3 \cdot \frac{-y}{3} = 3 \cdot 4$$

Multiply both sides by 3.

$$-y = 12$$

$$-1 \cdot y = 12$$

Rewrite the equation.

$$-1 \cdot (-1 \cdot y) = -1 \cdot 12$$

Multiply both sides by -1 .

$$y = -12$$

Simplify.

CHECK

$$\begin{array}{r} \frac{-y}{3} \stackrel{?}{=} 4 \\ -(-12) \bigg| 4 \\ \hline 3 \\ \frac{12}{3} \\ \hline 4 \end{array}$$

The solution $y = -12$ is correct.

c. $-3.2z = 6.4$ Given.

$$\frac{-3.2z}{-3.2} = \frac{6.4}{-3.2}$$

Divide both sides by -3.2 .

$$z = -2$$

Simplify.

CHECK Replace z with -2 in the original equation.

$$\begin{array}{r} -3.2z \stackrel{?}{=} 6.4 \\ -3.2(-2) \bigg| 6.4 \\ \hline 6.4 \end{array}$$

Thus, the solution is $z = -2$.

B > Solving Linear Equations

Unfortunately, not all equations are as simple as the ones discussed. Moreover, we must know what procedure to follow when confronted with any linear equation. Here is the way to do it:

PROCEDURE FOR SOLVING LINEAR EQUATIONS

1. Simplify both sides of the equations, if necessary.
2. Add or subtract the same numbers to or from both sides of the equation so that one side contains variables only.
3. Add or subtract the same terms to or from both sides of the equation so that the other side contains numbers only.
4. If the coefficient of the variable (the number multiplied by the variable) is not 1, divide both sides of the equation by this number.
5. The resulting number is the solution of the equation. Check in the original equation to be sure it is correct.

Remember, the goal when solving an equation is to have the variable by itself (isolated) on one side of the equation.

We will follow these steps to solve the equation $3(x + 1) = x + 7$.

Step 1. $3(x + 1) = x + 7$

$$3x + 3 = x + 7$$

Simplify. $3(x + 1) = 3x + 3$

Step 2. $3x + 3 - 3 = x + 7 - 3$

$$3x = x + 4$$

Subtract 3.

Step 3. $3x - x = x - x + 4$

$$2x = 4$$

Subtract x .

Step 4. $\frac{2x}{2} = \frac{4}{2}$

Divide by 2.

Step 5. $x = 2$

CHECK

$$\begin{array}{r|l} 3(x + 1) & \stackrel{?}{=} x + 7 \\ 3(2 + 1) & 2 + 7 \\ 3(3) & 9 \\ \hline 9 & 9 \end{array}$$

Of course, not all equations involve every step. We will give some examples so that you can see how it is done. A general rule to follow is that we wish to have the variables on one side of the equation and the numbers on the other side.

EXAMPLE 3 Solving a linear equation

Solve: $-3x + 6 = 10$.

SOLUTION 3 We use the given steps.

Step 1. The equation is already simplified.

$$-3x + 6 = 10$$

Step 2. Subtract 6 from both sides.

$$-3x + 6 - 6 = 10 - 6$$

Step 3. The right-hand side has numbers only.

$$-3x = 4$$

Step 4. Divide by the coefficient of x , that is, by -3 .

$$\frac{-3x}{-3} = \frac{4}{-3}$$

Step 5.

$$x = -\frac{4}{3}$$

CHECK

$$\begin{array}{r|l} -3x + 6 & \stackrel{?}{=} 10 \\ -3 \cdot \left(-\frac{4}{3}\right) + 6 & 10 \\ 4 + 6 & \\ \hline 10 & \end{array}$$

The solution is $x = -\frac{4}{3}$.

PROBLEM 3

Solve: $-2x + 6 = 9$.

EXAMPLE 4 Solving a linear equation

Solve: $2x - 5 = 7$.

SOLUTION 4

Step 1. The equation is already simplified.

$$2x - 5 = 7$$

Step 2. Add 5 to both sides.

$$2x - 5 + 5 = 7 + 5$$

Step 3. The right-hand side has numbers only.

$$2x = 12$$

Step 4. Divide by the coefficient of x , that is, by 2.

$$\frac{2x}{2} = \frac{12}{2}$$

Step 5.

$$x = 6$$

PROBLEM 4

Solve: $3x - 5 = 7$.

(continued)

Answers to PROBLEMS

3. $x = -\frac{3}{2}$ 4. $x = 4$

CHECK
$$\begin{array}{r|l} 2x - 5 \stackrel{?}{=} 7 & \\ 2(6) - 5 & 7 \\ 12 - 5 & \\ 7 & \end{array}$$

The solution is $x = 6$.

EXAMPLE 5 Solving a linear equation involving decimals

Solve: $3x + 5.6 = x + 7.8$.

SOLUTION 5

Step 1. The equation is already simplified.

$$3x + 5.6 = x + 7.8$$

Step 2. Subtract 5.6 from both sides.

$$3x + 5.6 - 5.6 = x + 7.8 - 5.6$$

$$3x = x + 2.2$$

Step 3. Subtract x from both sides so that there is no variable on the right-hand side of the equation.

$$3x - x = x - x + 2.2$$

$$2x = 2.2$$

Step 4. Divide by the coefficient of the variable, that is, by 2.

$$\frac{2x}{2} = \frac{2.2}{2}$$

$$x = 1.1$$

Step 5.

CHECK
$$\begin{array}{r|l} 3x + 5.6 \stackrel{?}{=} x + 7.8 & \\ 3(1.1) + 5.6 & 1.1 + 7.8 \\ 3.3 + 5.6 & 8.9 \\ 8.9 & \end{array}$$

The solution is $x = 1.1$.

PROBLEM 5

Solve: $3x + 2.4 = x + 8.6$.

EXAMPLE 6 Solving a linear equation containing parentheses

Solve: $4(x + 1) = 2x + 12$.

SOLUTION 6

Step 1. Simplify.

$$4(x + 1) = 2x + 12$$

$$4x + 4 = 2x + 12$$

Step 2. Subtract 4 from both sides.

$$4x + 4 - 4 = 2x + 12 - 4$$

$$4x = 2x + 8$$

Step 3. Subtract $2x$ from both sides.

$$4x - 2x = 2x - 2x + 8$$

$$2x = 8$$

Step 4. Divide by the coefficient of x , that is, by 2.

$$\frac{2x}{2} = \frac{8}{2}$$

Step 5.

$$x = 4$$

CHECK
$$\begin{array}{r|l} 4(x + 1) \stackrel{?}{=} 2x + 12 & \\ 4(4 + 1) & 2(4) + 12 \\ 4(5) & 8 + 12 \\ 20 & 20 \end{array}$$

The solution is $x = 4$.

PROBLEM 6

Solve: $5(x + 2) = 2x + 19$.

EXAMPLE 7 Solving a linear equation involving parentheses

Solve: $20 = 5(x + 2)$.

SOLUTION 7 Before solving this equation, remember that we wish to have the variables on one side of the equation and the numbers on the other side.

PROBLEM 7

Solve: $10 = 2(x + 3)$.

Answers to PROBLEMS

5. $x = 3.1$ 6. $x = 3$ 7. $x = 2$

Step 1. Simplify.

$$20 = 5(x + 2)$$

$$20 = 5x + 10$$

Step 2. Subtract 10 from both sides.

$$20 - 10 = 5x + 10 - 10$$

$$10 = 5x$$

Step 3. There is no variable on the left-hand side.

Step 4. Divide both sides by 5.

$$\frac{10}{5} = \frac{5x}{5}$$

Step 5.

$$2 = x$$

$$x = 2$$

CHECK

$$\begin{array}{r|l} 20 = 5(x + 2) & \\ 20 & 5(2 + 2) \\ & 5(4) \\ & 20 \end{array}$$

The solution is $x = 2$.

EXAMPLE 8 Solving linear equations involving fractions

Solve.

a. $\frac{2}{3}x = -5$

b. $\frac{1}{8}x - \frac{3}{8} + \frac{1}{2}x = \frac{1}{2} + x$

SOLUTION 8

a. Since all the x 's are alone on the left side, we can skip steps 1, 2, and 3. The coefficient of x is $\frac{2}{3}$, so we can *divide* both sides by $\frac{2}{3}$. By the definition of division of fractions, dividing by $\frac{2}{3}$ is the same as *multiplying* by the *reciprocal* of $\frac{2}{3}$ —that is multiplying by $\frac{3}{2}$. Since it is easier to multiply both sides by $\frac{3}{2}$, we proceed in that fashion.

$$\frac{2}{3}x = -5 \quad \text{Given.}$$

$$\frac{3}{2} \cdot \frac{2}{3}x = \frac{3}{2} \cdot (-5) \quad \text{Multiply both sides by } \frac{3}{2}.$$

$$x = -\frac{15}{2} \quad \text{Simplify.}$$

CHECK

$$\frac{2}{3}x \stackrel{?}{=} -5$$

$$\begin{array}{r|l} \frac{2}{3} \left(-\frac{15}{2} \right) & -5 \\ -5 & \end{array}$$

Thus, the solution is $x = -\frac{15}{2}$.

b. We can start by combining like terms, but we can make the problem easier if we multiply both sides by the LCD of all terms (8). This is an *optional* step, but it will save work. Here is the procedure.

$$\frac{1}{8}x - \frac{3}{8} + \frac{1}{2}x = \frac{1}{2} + x \quad \text{Given.}$$

$$8 \cdot \left(\frac{1}{8}x - \frac{3}{8} + \frac{1}{2}x \right) = 8 \cdot \left(\frac{1}{2} + x \right) \quad \text{Multiply both sides by 8.}$$

$$8 \cdot \frac{1}{8}x - 8 \cdot \frac{3}{8} + 8 \cdot \frac{1}{2}x = 8 \cdot \frac{1}{2} + 8 \cdot x \quad \text{Simplify.}$$

$$x - 3 + 4x = 4 + 8x$$

$$5x - 3 = 4 + 8x$$

Now, on which side of the equation should we leave the x 's? It is easier (because it avoids expressions with a negative sign in front) to leave the x 's on the right.

(As a rule of thumb, leave the x 's on the side that has more of them.) Here is the rest of the problem.

PROBLEM 8

Solve.

a. $\frac{3}{4}x = -2$

b. $\frac{1}{3}x - \frac{1}{4} + \frac{3}{4}x = \frac{1}{3} + 2x$

Answers to PROBLEMS

8. a. $x = -\frac{8}{3}$ b. $x = -\frac{7}{11}$

(continued)

Step 1. The equation is simplified.

$$5x - 3 = 4 + 8x$$

Step 2. Subtract 4 from both sides.

$$5x - 3 - 4 = 4 - 4 + 8x$$

$$5x - 7 = 8x$$

Step 3. Subtract $5x$ from both sides.

$$5x - 5x - 7 = 8x - 5x$$

$$-7 = 3x$$

Step 4. Divide both sides by 3.

$$-\frac{7}{3} = \frac{3x}{3}$$

Step 5.

$$x = -\frac{7}{3}$$

The check is left for you. The solution is $x = -\frac{7}{3}$.

When solving Example 8b, we introduced two new steps that have to be done when solving a linear equation involving fractions: **C**learing the fractions (by multiplying both sides of the equation by the LCD) and **R**emoving parentheses. You can remember the steps to use if you remember to **CRAM** as shown next.

PROCEDURE FOR SOLVING LINEAR EQUATIONS (CRAM)

Clear fractions by multiplying both sides of the equation by the LCD.

Remove parentheses (simplify).

Add or subtract numbers and expressions so the variables are on one side (isolated).

Multiply or divide by the coefficient of the variable.

The prediction that the “greenhouse effect” will modify the climates around the world is well known. According to the projections made in 1992 by the Intergovernmental Panel on Climate Change, sea levels will rise about 18 cm by 2040 and 48 cm by 2100. Is there an equation that will model these data and can we make further predictions based on that equation? We will do that in Example 9.

GREEN MATH

EXAMPLE 9 Sea Level Increases

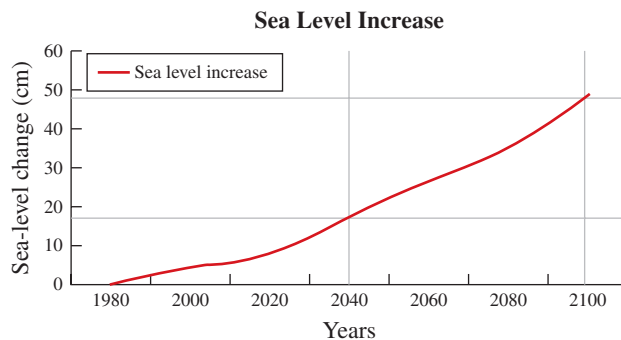

The graph shows the sea level increases y (in cm) from 1980 to 2100 and can be approximated by the equation

$$y = 0.5x - 2 \text{ (cm)}$$

where x is the number of years after 2000.

In Bangladesh, land would be flooded by a rise in sea level of 50 cm.

In what year does the equation predict that will occur?

PROBLEM 9

Use the equation to predict the year in which the sea level increase will be 20 cm.

Answers to PROBLEMS

9. $x = 44$ years, that is, in 2044.

SOLUTION 9

Since we want to know when the sea level increase y will be 50, we have to solve the equation $50 = 0.5x - 2$

Step 1. The equation is already simplified.

$$50 = 0.5x - 2$$

Step 2. Add 2 to both sides.

$$50 + 2 = 0.5x - 2 + 2$$

$$52 = 0.5x$$

Step 3. All variables are on the right-hand side.

Step 4. Divide both sides by 0.5.

$$\frac{52}{0.5} = \frac{0.5x}{0.5}$$

Step 5. Note that $\frac{52}{0.5} = 104$.

$$104 = x$$

Thus, the solution is $x = 104$ years after 2000, or 2104. Note that this is consistent with the graph.

> Exercises 10.4

> Practice Problems > Self-Tests
> Media-rich eBooks > e-Professors > Videos

< A > Solving Equations Using the Addition, Subtraction, Multiplication, or Division Principle

In Problems 1–26, solve the equation.

- | | | |
|-------------------------------------|------------------------------------|-------------------------------------|
| 1. $x - 2 = -4$ | 2. $-7 = y - 5$ | 3. $-\frac{3}{4} = y - \frac{1}{4}$ |
| 4. $-\frac{4}{5} = x - \frac{1}{5}$ | 5. $x - 1.9 = -8.9$ | 6. $y - 3.7 = -9.7$ |
| 7. $\frac{1}{2} = y + \frac{1}{5}$ | 8. $\frac{1}{3} = x + \frac{1}{4}$ | 9. $x + 3.8 = 9.9$ |
| 10. $y + 2.5 = 6.9$ | 11. $-x = 8$ | 12. $-y = 3$ |
| 13. $-y = -\frac{1}{5}$ | 14. $-x = -\frac{1}{7}$ | 15. $-x = 2.3$ |
| 16. $-y = 5.7$ | 17. $\frac{-x}{2} = 8$ | 18. $\frac{-y}{3} = 7$ |
| 19. $3.1 = \frac{-y}{4}$ | 20. $2.2 = \frac{-x}{5}$ | 21. $-2.1z = 4.2$ |
| 22. $-3.8z = 1.9$ | 23. $-1.2 = 2.4x$ | 24. $-1.8 = 3.6x$ |
| 25. $3.6y = 4.8$ | 26. $6.4y = 3.2$ | |

< B > Solving Linear Equations In Problems 27–60, solve the equation.

- | | | |
|---|---|---|
| 27. $2x + 7.1 = 9.3$ | 28. $3y + 7.2 = 13.8$ | 29. $6.5 = 3y + 3.2$ |
| 30. $21 = 2.5x + 1$ | 31. $\frac{3}{5}x - \frac{6}{5} = \frac{4}{5}$ | 32. $\frac{3}{5}y - \frac{2}{5} = \frac{4}{5}$ |
| 33. $\frac{1}{3} = \frac{5}{2}x - \frac{8}{3}$ | 34. $\frac{1}{2} = \frac{3}{4}x - \frac{3}{2}$ | 35. $3.5x + 5 = 1.5x + 7$ |
| 36. $20 - 3.3x = 5.7x + 2$ | 37. $21 - 1.5y = 6.5y + 5$ | 38. $2(x + 5) = -12$ |
| 39. $3(y + 2) = -24$ | 40. $8(y - 1) = y + 2$ | 41. $6(x - 1) = x + 6$ |
| 42. $x + 5 = -3(x + 1)$ | 43. $y + 6 = -2(y + 2)$ | 44. $11 - x = 4(x - 1)$ |
| 45. $1 - y = 5(y - 1)$ | 46. $2x + 1 = 3(x + 1)$ | 47. $3x + 1 = 2(x + 1)$ |
| 48. $5x + 1 = -5x + 1$ | 49. $6x + 2 = -6x + 2$ | 50. $7x + 3 = -7x + 3$ |
| 51. $\frac{3}{5}x = -4$ | 52. $\frac{2}{7}y = -3$ | 53. $-\frac{3}{8}y = 2$ |
| 54. $-\frac{4}{5}x = 3$ | 55. $-\frac{2}{5}x = -3$ | 56. $-\frac{3}{7}y = -2$ |
| 57. $\frac{5}{6}y - \frac{1}{4} = \frac{1}{2} - \frac{2}{3}y$ | 58. $\frac{3}{5}x + \frac{2}{3} = \frac{4}{3} + \frac{9}{5}x$ | 59. $\frac{3}{2}y - \frac{1}{3} = \frac{5}{4}y + \frac{1}{8}$ |
| 60. $\frac{4}{9}x - \frac{3}{2} = \frac{5}{6}x - \frac{3}{2}$ | | |

Applications: Green Math

Temperature changes

61. The change in temperature y (in degrees Celsius) is 0.025 times x , the number of years after the year 2000.

- Write an equation for this situation.
- What principle will you use to solve for x ?

62. The Temperature Increase graph can be approximated by

$$y = 0.025x \text{ (cm)}$$

where x is the number of years after 2000.

- In what year will the temperature change be 1°C (one degree Celsius)?
- In what year will the temperature change be 2.5°C ?
- Do your answers to parts **a** and **b** correspond to the information in the graph?

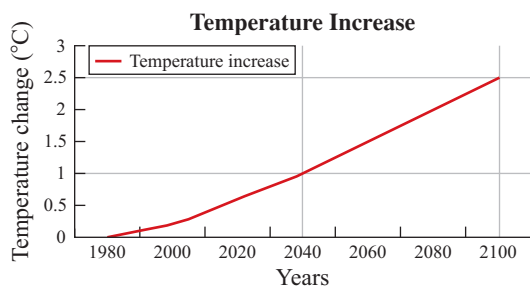

Source: <http://www.lenntech.com/The-greenhouse-effect.htm>.

63. The British government has warned that a 3°C rise in temperature “could trigger the melting of the Greenland ice cap, the destabilization of the Antarctic, and cause irreversible system disruptions.” Use the formula to find in what year the temperature will rise by 3°C .

Source: *The Guardian*, Monday 8 May 2006.

64. A 2°C rise in the average world temperature will change the nature of the monsoon climate that brings abundant rainfall, leading to widespread drought and more elderly people dying of heat in homes with no electricity due to disruption of hydroelectric plants. Use the formula to find in what year the temperature will rise by 2°C .

Source: Editorial writer Chung Sung-hee, Korea.

Using Your Knowledge

The weekly salary of a salesperson is given by

$$\begin{array}{ccccc} \text{Salary} & & \text{Commission} & & \text{Total pay} \\ S & + & C & = & T \end{array}$$

65. If the person made \$66 on commissions and the total pay was \$176, what was the person's salary?

66. If a person's salary was \$133 and the total pay was \$171, how much did the person earn in commissions?

Your bank balance is given by

$$\begin{array}{ccccc} \text{Deposits} & & \text{Withdrawals} & & \text{Balance} \\ D & - & W & = & B \end{array}$$

67. A person deposited \$308. The balance was \$186. How much money did the person withdraw from her account?

68. The balance in a checking account was \$147. The deposits were \$208. How much money was withdrawn from the account?

The weight of a man is related to his height by

$$\begin{array}{ccccc} \text{Weight (pounds)} & & \text{Height (in inches)} & & \\ W & = & 5H & - & 190 \end{array}$$

69. A man weighs 160 pounds. What is his height?

>>> Write On

70. Write in your own words the difference between an expression and an equation.
71. When solving the equation $-\frac{3}{4}x = 6$, would it be easier to multiply by the reciprocal $-\frac{4}{3}$ or to divide both sides by $-\frac{3}{4}$?
72. Describe in your own words the solution of an equation. Can you make an equation with no solution?

>>> Concept Checker

Fill in the blank(s) with the correct word(s), phrase, or mathematical statement.

73. An _____ is a **sentence having a variable** in which the verb is *equals*.
74. By the **addition principle**, the equation $a = b$ is equivalent to _____.
75. By the **subtraction principle**, the equation $a = b$ is equivalent to _____.
76. By the **multiplication principle**, the equation $a = b$ is equivalent to _____.
77. By the **division principle**, the equation $a = b$ is equivalent to _____.
78. The **first step** in the procedure for solving an equation is to _____ both sides of the equation.

simplify

$$\frac{a}{c} = \frac{b}{c}, c \neq 0$$

$$a \cdot c = b \cdot c$$

$$a - c = b - c$$

$$a + c = b + c$$

multiply

equation

>>> Mastery Test

Solve the equation.

79. $x - 3 = -4$

82. $\frac{-x}{4} = 3$

85. $3x - 6 = 9$

88. $30 = 6(x + 2)$

80. $y + \frac{1}{4} = \frac{1}{2}$

83. $-3.3z = 9.9$

86. $4x + 6.6 = x + 7.8$

89. $\frac{2}{3}x = -6$

81. $-y = 7$

84. $-4x + 6 = 9$

87. $3(x + 1) = 2x + 7$

90. $\frac{1}{8}x - \frac{1}{8} + \frac{1}{2}x = \frac{3}{4} + x$

>>> Skill Checker

In Problems 91–92, multiply:

91. $\frac{2}{3} \cdot 1000$

92. $\frac{3}{4} \cdot 500$

In Problems 93–94, divide:

93. $67.50 \div 0.25$

94. $90.3 \div 0.15$

10.5

Applications: Word Problems

Objective

A > You should be able to solve word problems using the RSTUV procedure.

To Succeed, Review How To . . .

1. Use the RSTUV method presented in Sections 2.8 and 3.5. (p. 95)
2. Solve equations. (pp. 91–94, 251–252, 634–640)

Getting Started

Do you believe the United States sent a mission to the moon? Some people don't, but the illustration shows the Lunar Rover used by the astronauts of *Apollo 15*. The weight of this vehicle on Earth (450 pounds) is 6 times the weight of the vehicle on the moon. What is the weight of the vehicle on the moon?

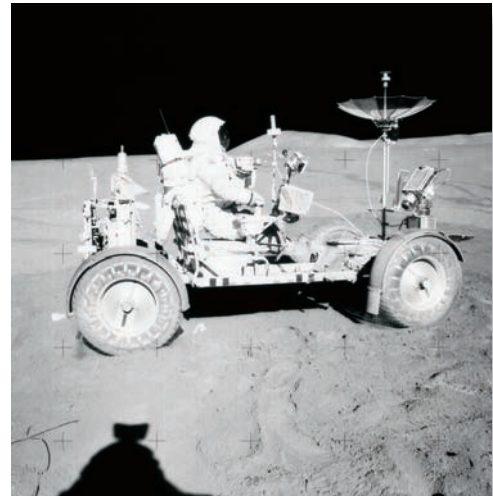

A > Solving Word Problems

In this section, we are going to use the language of algebra and translate word sentences into equations. We will then solve these equations using the methods of the previous section and the **RSTUV** procedure we studied in Section 2.8. We repeat the procedure here for your convenience.

RSTUV PROCEDURE TO SOLVE WORD PROBLEMS

1. Read the problem carefully and decide what is asked for (the *unknown*).
2. Select \square or a letter to represent the unknown.
3. Translate the problem into an equation.
4. Use the rules we have studied to solve the equation.
5. Verify the answer.

We now use these five steps to solve the problem in the *Getting Started*.

- Step 1.** Read the problem. Decide what number is asked for. In our problem we are asked for the weight of the vehicle on the moon.
- Step 2.** Select w to represent the weight of the vehicle on the moon.

Step 3. Translate. According to the problem,

$$\begin{array}{ccc} \text{The weight of the} & \text{is} & \text{6 times the weight of} \\ \text{vehicle on Earth} & & \text{the vehicle on the moon.} \\ \downarrow & & \downarrow \\ 450 & = & 6w \end{array}$$

Step 4. Use algebra to solve the equation $450 = 6w$:

$$\begin{aligned} 450 &= 6w \\ \frac{450}{6} &= \frac{6w}{6} && \text{Divide both sides by 6.} \\ w &= 75 \end{aligned}$$

Step 5. Verify the requirements of the problem. Is the weight of the vehicle on Earth (450 pounds) 6 times the weight of the vehicle on the moon? Since $450 = 6 \cdot 75$, our answer is correct. Thus the weight of the vehicle on the moon is 75 pounds.

EXAMPLE 1 Problem solving: Astronauts

One of the moon astronauts, Eugene “Buzz” Aldrin, weighed 180 pounds on Earth. His Earth weight was 6 times his weight on the moon. How much did he weigh on the moon?

SOLUTION 1 We proceed by steps.

Step 1. Read the problem carefully and decide what number it asks for. It asks for Aldrin’s weight on the moon.

Step 2. Select w to be this weight.

Step 3. Translate. According to the problem,

$$\begin{array}{ccc} \text{His Earth weight} & \text{is} & \text{6 times his weight} \\ & & \text{on the moon.} \\ \downarrow & & \downarrow \\ 180 & = & 6w \end{array}$$

Step 4. Use algebra to solve $180 = 6w$:

$$\begin{aligned} 180 &= 6w \\ \frac{180}{6} &= \frac{6w}{6} && \text{Divide by 6.} \\ 30 &= w \\ w &= 30 \end{aligned}$$

Step 5. Verify. Is it true that $180 = 6 \cdot 30$? Yes, our answer is correct. Thus, Aldrin’s weight on the moon was 30 pounds.

PROBLEM 1

Another astronaut, Neil Armstrong, weighed 162 pounds on Earth. This weight was 6 times his weight on the moon. How much did he weigh on the moon?

EXAMPLE 2 Problem solving: Dieting

Celesta Geyer, alias Dolly Dimples, decreased her weight by 401 pounds, to 152, in 14 months. How much did she weigh at the beginning of her diet?

SOLUTION 2

Step 1. Read the problem carefully and find out what we are asked for. In this problem we want to know her weight at the beginning of the diet.

Step 2. Select w to be this weight.

Step 3. Translate. According to the problem,

$$\begin{array}{ccc} \text{She decreased her} & & \text{152.} \\ \text{weight by 401} & \text{to} & \downarrow \\ \downarrow & & \downarrow \\ w - 401 & = & 152 \end{array}$$

PROBLEM 2

Paul Kimmelman holds the speed record for weight reducing. His weight decreased by 357 pounds, to 130, in about eight months. How much did he weigh at the beginning of his diet?

(continued)

Answers to PROBLEMS

1. 27 lb 2. 487 lb

Step 4. Use algebra to solve $w - 401 = 152$:

$$\begin{aligned} w - 401 &= 152 \\ w - 401 + 401 &= 152 + 401 \quad \text{Add 401 to both sides.} \\ w &= 553 \end{aligned}$$

Step 5. Verify the answer. Since $553 - 401 = 152$, our result is correct. Thus, her weight was 553 pounds.

EXAMPLE 3 Problem solving: Anthropology

Do you know how anthropologists classify the different forms of humans? By measuring the brain in cubic centimeters. *Homo erectus*, of which two subspecies have been identified, had a brain that was 1000 cubic centimeters, or about $\frac{2}{3}$ that of a modern person. How many cubic centimeters of brain does a modern person have?

SOLUTION 3

Step 1. Read the problem. It asks for the number of cubic centimeters of brain in a modern person.

Step 2. Select c to be this number.

Step 3. Translate. According to the problem,

$$\begin{array}{ccc} \underbrace{\text{Homo erectus had a brain}}_{\text{that was } 1000 \text{ cm}^3} & \text{or} & \underbrace{\text{about } \frac{2}{3} \text{ that of}}_{\text{modern humans.}} \\ \downarrow & & \downarrow \\ 1000 & = & \frac{2}{3}c \end{array}$$

Step 4. Use algebra to solve the equation $1000 = \frac{2}{3}c$:

$$\begin{aligned} 1000 &= \frac{2}{3}c \\ \frac{3}{2} \cdot 1000 &= \frac{3}{2} \cdot \frac{2}{3}c \quad \text{Multiply both sides by the reciprocal of } \frac{2}{3}, \frac{3}{2}. \\ \frac{3000}{2} &= c \\ c &= 1500 \end{aligned}$$

Step 5. Verify the answer. Since

$$1000 = \frac{2}{3} \cdot 1500 = 1000$$

our result is correct. Thus, a modern person has 1500 cubic centimeters of brain volume.

EXAMPLE 4 Problem solving: Renting a car

The daily cost C (in dollars) of renting a car is \$20 plus \$0.25 per mile traveled. If m is the number of miles traveled, then

$$C = 20 + 0.25m$$

An executive rents a car for a day and pays \$87.50. How many miles did the executive travel?

SOLUTION 4

Step 1. Read the problem. It asks for the number of miles traveled.

Step 2. Select m to be this number.

Step 3. Translate. According to the problem,

$$C = 20 + 0.25m$$

or

$$87.50 = 20 + 0.25m$$

PROBLEM 3

Water is made up of eight parts of oxygen and one of hydrogen by weight, which means that $\frac{8}{9}$ of water is oxygen. If the amount of oxygen in a bucket of water is 368 grams, how much water is there in the bucket?

PROBLEM 4

The daily cost of renting a car is given by

$$C = 15 + 0.20m$$

where C is the daily cost (in dollars) and m the number of miles traveled. A person rented a car for a day and paid \$65. How many miles did the person travel?

Answers to PROBLEMS

3. 414 g 4. 250 miles

Step 4. Use algebra to solve the equation.

$$\begin{aligned}
 87.50 &= 20 + 0.25m \\
 87.50 - 20 &= 20 - 20 + 0.25m && \text{Subtract 20.} \\
 67.50 &= 0.25m && \text{Simplify.} \\
 \frac{67.50}{0.25} &= m && \text{Divide by 0.25.} \\
 270 & && \\
 0.25 \overline{)67.50} & && \\
 \underline{50} & && \\
 175 & && \\
 \underline{175} & && \\
 00 & &&
 \end{aligned}$$

Thus, $m = 270$.

Step 5. Verify the answer. Since $0.25 \cdot 270 + 20 = 67.50 + 20 = 87.50$, our result is correct. Thus, the executive traveled 270 miles.

EXAMPLE 5 Problem solving: Rate of interest

Angie bought a 6-month, \$10,000 certificate of deposit in Venezuela. At the end of the 6 months, she received \$650 simple interest. What rate of interest did the certificate pay?

SOLUTION 5

Step 1. Read the problem. It asks for the rate of simple interest.

Step 2. Select the variable r to represent this rate.

Step 3. Translate the problem. Here, we need to know that the formula for simple interest is

$$I = Prt$$

where I is the amount of interest, P is the principal, r is the interest rate, and t is the time in years. For our problem, $I = \$650$, $P = \$10,000$, r is unknown, and $t = \frac{1}{2}$ year. Thus, we have

$$\begin{aligned}
 650 &= (10,000)(r)\left(\frac{1}{2}\right) \\
 650 &= 5000r
 \end{aligned}$$

Step 4. Use algebra to solve the equation.

$$\begin{aligned}
 650 &= 5000r \\
 \frac{650}{5000} &= r && \text{Divide by 5000.} \\
 r &= 0.13 = 13\%
 \end{aligned}$$

Step 5. Verify the answer. Is the interest earned on a \$10,000, 6-month certificate at a 13% rate \$650? Evaluating Prt , we have

$$(10,000)(0.13)\left(\frac{1}{2}\right) = 650$$

Since the answer is yes, 13% is correct. The certificate paid 13% simple interest.

PROBLEM 5

Angel bought a 6-month, \$10,000 certificate of deposit in Brazil. At the end of the 6 months, he received \$600 simple interest. What rate of interest did the certificate pay?

You have probably noticed the frequent occurrence of certain words in the statements of word problems. Because these words are used often, here is a small mathematics dictionary to help you translate them properly.

Answers to PROBLEMS

5. 12%

Mathematics Dictionary

Words	Translation	Example	Translation
Add, more than, sum, increased by, added to	+	Add n to 7 7 more than n The sum of n and 7 n increased by 7 7 added to n	$n + 7$
Subtract, less than, minus, difference, decreased by, subtracted from	-	Subtract 9 from x 9 less than x x minus 9 Difference of x and 9 x decreased by 9 9 subtracted from x	$x - 9$
Of, the product, times, multiply by	\times	$\frac{1}{2}$ of a number x The product of $\frac{1}{2}$ and x $\frac{1}{2}$ times a number x Multiply $\frac{1}{2}$ by x .	$\frac{1}{2}x$
Divide, divided by, the quotient	\div	Divide 10 by x . 10 divided by x The quotient of 10 and x	$\frac{10}{x}$
The same, yields, gives, is	=	$\frac{6}{3}$ is the same as 2. 6 divided by 3 yields 2. 6 divided by 3 gives 2. The quotient of 6 and 3 is 2.	$\frac{6}{3} = 2$

Before we practice solving some more word problems, let us see how the words contained in the mathematics dictionary are used in real life.

GREEN MATH

EXAMPLE 6 Translating recycling facts into expressions

Translate the sentence into a mathematical expression.

- The 63 million tons of garbage recovered in a certain year is 1.9 million tons more than the T million tons recovered the year before.
- The 64.3% of steel cans recycled in a recent year is 35% less than the percent A of auto batteries recycled.
- The difference in the percent S of steel cans recycled and the 64.1% of yard trimmings recycled is only 0.02%.

SOLUTION 6

- The key words are *more than*, which means $+$. The translation is $63 = T + 1.9$
- The key words are *less than*, which means $-$. The translation is $64.3\% = A - 35\%$
- The key word is *difference*, which means $-$. The translation is $S - 64.1\% = 0.02\%$

Source: <http://www.epa.gov/epawaste/nonhaz/municipal/pubs/msw07-fs.pdf>.

PROBLEM 6

Translate the sentence into a mathematical expression.

- The percent G of glass containers recycled is only 0.1% more than the 28% R of plastic milk and water bottles recycled.
- 48.6% of aluminum beer and soda cans recycled is exactly half of the percent A of auto batteries recycled.
- The difference in the percent G of glass containers recycled and the 28% R of plastic milk and water bottles recycled is 0.1%.

Answers to PROBLEMS

6. a. $G = 28\%R + 0.1\%$ b. $48.6\% = \frac{1}{2}A$ c. $G - 28\%R = 0.1\%$

EXAMPLE 7 Problem solving: Integers

If 7 is added to twice a number n , the result is 9 times the number. Find the number.

SOLUTION 7

Step 1. Read the problem.

Step 2. Select n to be the number.

Step 3. Translate the problem.

$$\begin{array}{ccccccc}
 & & \text{added} & & \text{twice a} & & \text{the result} & & \text{9 times} \\
 & & \text{to} & & \text{number } n & & \text{is} & & \text{the number.} \\
 \text{If 7 is} & & & & & & & & \\
 \downarrow & & \downarrow & & \downarrow & & \downarrow & & \downarrow \\
 7 & + & 2n & = & 9n
 \end{array}$$

Step 4. Use algebra to solve the equation.

$$\begin{array}{rcl}
 7 + 2n = 9n & & \\
 7 + 2n - 2n = 9n - 2n & \text{Subtract } 2n. & \\
 7 = 7n & \text{Simplify.} & \\
 \frac{7}{7} = \frac{7n}{7} & \text{Divide by 7.} & \\
 1 = n & &
 \end{array}$$

Step 5. Verify the answer. Is $7 + 2(1) = 9(1)$? Since $7 + 2 = 9$, our result is correct. The answer is 1.

EXAMPLE 8 Problem solving: Hamburger calories

A McDonald's hamburger and large fries contain 820 calories. Which has more calories, the burger or the fries? The fries, of course! In fact, the fries have almost *double* the number of calories of the burger, but not quite. The exact relationship is *if you double the calories in the hamburger and reduce the result by 20, you will have the same number of calories as are in the fries*. How many calories are in the hamburger and how many are in the fries?

SOLUTION 8

Step 1. Read the problem.

Step 2. Select h to be the number of calories in the hamburger and f to be the number of calories in the fries.

Step 3. Translate the problem.

If you double the calories in the hamburger ($2h$) and reduce the result by 20, you will have the same number of calories as are in the fries (f), that is, $2h - 20 = f$.

However, $2h - 20 = f$ has two variables. Anything missing?

Yes, the 820. It does say at the beginning of the problem that a McDonald's hamburger and large fries contain 820 calories.

$$\begin{array}{rcl}
 \text{That is,} & h & + & f & = & 820 \\
 \text{Substituting for } f & h & + & (2h - 20) & = & 820
 \end{array}$$

Step 4. Use algebra to solve.

$$\begin{array}{rcl}
 3h & - & 20 = 820 & \text{Simplify.} \\
 3h & & = 840 & \text{Add 20.} \\
 h & & = 280 & \text{Divide by 3.}
 \end{array}$$

To find the calories in the fries, double 280 and subtract 20 to get 540 calories ($2 \cdot 280 - 20 = 540$) for the fries.

Step 5. Verify the answer. Since $h = 280$ and $f = 540$, we substitute those numbers in the original equation:

$$\begin{array}{rcl}
 h + f & = & 820 \\
 280 + 540 & = & 820 \\
 820 & = & 820
 \end{array}$$

So the results for h and f are correct.

PROBLEM 7

If 6 is added to 3 times a number, the result is 6 times the number. Find the number.

PROBLEM 8

Believe it or not, if you eat a Burger King hamburger with large fries, you will also get 820 calories. However, if you double the calories in the burger, you will have 140 more calories than are in the fries. How many calories are in each?

Answers to PROBLEMS

7. 2 8. $h = 320; f = 500$

Before you attempt to solve the exercises, practice translating!

TRANSLATE THIS

- The amount of financial aid F received by graduate and undergraduate students in a recent year was \$122 billion plus 11% over the amount P received the preceding year.
 - The \$23 billion distributed by colleges and universities in grant aid represents 19% of total student aid funds F .
- Source:* The College Board.
- In a recent year, the average federal grant to students was \$2421, which falls \$24,000 short of Tuition and Fees TF at Harvard.
 - A survey of T employed American adults indicated that $\frac{1}{2}$ of them pay off debt when they receive extra money. This represents 1365 of the people surveyed.
 - The speed D (in centimeters per second) of an ant is the product of $\frac{1}{6}$ and the difference of C and 4 (C the temperature in degrees Celsius).

The third step in the RSTUV procedure is to **TRANSLATE** the information into an equation. In Problems 1–10, **TRANSLATE** the sentence and match the correct translation with one of the equations A–O.

- $2421 = TF - 24,000$
- $D = \frac{1}{6}(C - 4)$
- $2421 - TF = 24,000$
- $23 = 0.19F$
- $D = \frac{1}{6}C - 4$
- $C = 35 + 40h$
- $y = b + mx$
- $N = 4(F - 40)$
- $F = 122 + 0.11P$
- $72,000 = M + (M + 10,000)$
- $F = 122 + 1.11P$
- $C = 40 + 35h$
- $N = 4F - 40$
- $\frac{1}{2}T = 1365$
- $0.60W = 300$

- The number of chirps N a cricket makes in 1 minute is the product of 4 and the difference of F and 40 (F the temperature in degrees Fahrenheit).
- The charges C from a plumbing company amounted to \$35 for the service call plus \$40 for each hour h spent on the job.
- The equation y of a line is the sum of b and the product of its slope m and the variable x .
- The number of 20-year-old females enrolled in the Student Center exceeds the number of males M by 10,000. Write an equation representing the total membership of 72,000 students enrolled.
- A survey of W young women, ages 15 to 24, found that 60% or 300 of them were currently involved in an ongoing abusive relationship.

> Exercises 10.5



> Practice Problems > Self-Tests
> Media-rich eBooks > e-Professors > Videos

< **A** > **Solving Word Problems** For Problems 1–30, try to estimate the answer, then follow the RSTUV procedure given in the text to solve the problems.

- A woman deposited \$300 in her savings account. At the end of the year, her balance was \$318. If this amount represents her \$300 plus interest, how much interest did she earn during the year?
- A man borrowed \$600 from a loan company. He made payments totaling \$672. If this amount is the original \$600 plus interest, how much interest did he pay?
- In a recent election the winning candidate received 10,839 votes, 632 more votes than the losing candidate. How many votes did the loser get?
- In a recent election the losing candidate received 9347 votes, 849 votes less than the winning candidate. How many votes did the winner get?
- The cost of an article is \$57. If the profit when selling it is \$11, what is the selling price of the article?
- In accounting,

$$\text{assets} - \text{owner's equity} = \text{liabilities}$$
 If the owner's equity is \$4787 and the liabilities \$1688, what are the assets?
- During strenuous exercise the flow of blood pumped by the heart is increased to four times its normal rate, reaching 40 pints per minute. How many pints of blood per minute does the heart pump when at rest?
- It takes 9 times as much steel as nickel to make stainless steel. If 81 tons of stainless steel are used in constructing a bridge, how many tons of nickel are needed?

- 11.** During strenuous exercise the number of breaths a person takes each minute increases to 5 times the normal rate, reaching 60 breaths per minute. How many breaths per minute should a person take when at rest?
- 13.** When a gas tank is $\frac{2}{3}$ full, it contains 18 gallons of gas. What is the capacity of this tank?
- 15.** The dome of the village church of Equord, Germany, is $\frac{1}{16}$ as high as the dome of St. Peter's Basilica. If the dome of the village church is 43.75 feet high, how high is the dome of St. Peter's Basilica?
- 17.** The price-earnings (P/E) ratio of a stock is given by the equation
- $$P/E = \frac{M}{E}$$
- where M is the market price of the stock and E is the earnings. If the P/E ratio of a stock earning \$3 per share is 12, what should the market value of the stock be?
- 19.** The best linguist of all times is Cardinal Giuseppe Caspar Mezzofanti, who can translate 186 languages and dialects. If he can translate 42 more languages than dialects, how many dialects can he translate?
- 21.** Brenda bought a \$1000 certificate of deposit. At the end of the year, she received \$80 simple interest. What rate of interest did the certificate pay?
- 23.** Tonya invested \$3000 in municipal bonds. At the end of the year, she received \$240 simple interest. What was the rate of interest paid by the bonds?
- 25.** A loan company charges \$588 for a 2-year loan of \$1400. What simple interest rate is the loan company charging?
- 27.** Eleven more than twice a number is 19. Find the number.
- 29.** If 6 is added to 7 times a number, the result is 69. Find the number.
- 12.** Nutritionists have discovered that a cup of coffee has 144 mg of caffeine, 3 times the amount contained in an average cola drink. How many milligrams are there in an average cola drink?
- 14.** A man is entitled to $\frac{3}{4}$ his pay when he retires. If he receives \$570 per month after retirement, what was his regular salary?
- 16.** The density of a substance is given by the equation
- $$d = \frac{m}{v}$$
- where m is the mass and v is the volume. If the density of sulfur is 2 grams per milliliter and the volume is 80 milliliters, what is the mass of the sulfur?
- 18.** Supporting tissues, like bones, ligaments, tendons, and fats make up $\frac{1}{3}$ of the body. If a woman has 40 pounds of supporting tissue in her body, what is her total weight?
- 20.** Mezzofanti can speak 6 more than 3 times the number of languages he uses in interviews. If he can speak 39 languages, how many languages does he use in interviews? (See Problem 19.)
- 22.** Hadish deposited \$800 in a savings account. At the end of the year, he received \$40 simple interest. What rate of interest did the account pay?
- 24.** Pedro buys a \$10,000, 3-month certificate of deposit. At the end of the 3 months, he receives simple interest of \$350. What was the rate of interest on the certificate?
- 26.** If 4 times a number is increased by 5, the result is 29. Find the number.
- 28.** The sum of 3 times a number and 8 is 29. Find the number.
- 30.** If the product of 3 and a number is decreased by 2, the result is 16. Find the number.

Problems 31–38 are based on a Websense, Inc., survey of Information Technology (IT) decision-makers conducted by Harris Interactive.

Source: <http://www.websense.com>.

- 31. Surfing at work** IT decision-makers estimate employees spend about 5.7 hours a week on personal surfing at work. Employees deny this claim. They say the 5.7 hours is 1.9 times as many hours as they are willing to admit. How many hours are employees willing to admit to personal surfing at work?
- 32. Surfing for the weather** When employees were asked what types of non-work-related websites they visited, 375 of them (75%), said they visited weather sites. How many employees were surveyed?



- 33. Unauthorized disk space** IT decision-makers estimate that 7.5% of their organization's total disk space is filled with non-work-related files (like music and photo files). If this 7.5% amounts to 600 gigabytes (gigs) of disk space, what is the total disk space (in gigs) for the company?
- 34. Unauthorized disk space** Mid-sized companies tend to have a greater percentage of their disk space taken up by non-work-related files: 10.1%. If this 10.1% of the total disk space amounts to 505 gigabytes (gigs) of space, what is the total disk space (in gigs) for this mid-sized company?



- 35. Total people** The survey covered exactly 851 people: 149 more employees than IT decision-makers. How many employees and how many IT decision-makers were surveyed?
- 36. Phishing** Do you know what phishing is? It is a type of fraud in which the perpetrator entices people to share passwords or credit card numbers so they can be used illegally at a later time. In the survey, about 4 out of 5 or 280 IT decision-makers reported that their employees had received a phishing attack. About how many IT decision-makers were surveyed?

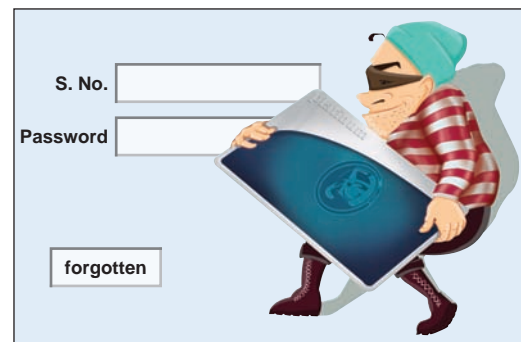

Source: www.plus.es.

- 37. Security breaches** What were the security breaches that could put their jobs at risk? They include system downtime (SD) due to viruses (50%), lost or stolen (LS) intellectual property (44%), and Internet security (IS) breaches (38%). And the survey said
- 20 fewer respondents answered LS than SD
42 fewer respondents answered IS than SD
- If the total number of responses was 463, how many responded SD, LS, and IS, respectively?

- 38. Intellectual loss** The loss of intellectual property is a main concern with IT decision-makers. Forty percent said they are very or extremely concerned (VE) with it, 35% say they are somewhat concerned (SC) with it, and 30% said they are not very (NV) or not at all concerned with it. If there are 35 fewer respondents answering NV than VE, 17 fewer respondents answering SC than VE, and the total number of respondents is 368, how many respondents are in each category? The percents add up to 105%, so multiple responses were allowed, presumably.

Problems 39–42 refer to another survey about viruses and the illnesses they cause conducted by Harris Interactive.

Source: <http://www.harrisinteractive.com>.

- 39. Survey coverage** The survey covered 1373 children and teenagers. The number of teens (13–18) surveyed exceed the number of tweens (8–12) by 227. How many teens and how many tweens were surveyed?
- 40. HIV/AIDS** Kids were asked if it was likely that they or one of their friends would catch HIV/AIDS. The number of teens that answered “yes” exceeded the number of tweens answering “yes” by 56. If the total number of “yes” answers was 216, how many teens and how many tweens answered “yes”?
- 41. Hepatitis C** Thirty-five more teens than tweens answered “yes” when asked if it was likely that they or one of their friends would catch hepatitis C. If the total number of “yes” answers was 173, how many teens and how many tweens answered “yes”?
- 42. Antibiotics** When they were asked if it was likely that they or one of their friends would use antibiotics, 61% of the tweens (349.53 of them), said “yes,” while 59% of the teens (472 of them) agreed. How many tweens and how many teens were surveyed?



Problems 43–50 are based on the article: How Many Calories Does Your Body Need?

Source: <http://www.briancalkins.com>.

43. Basal metabolic rate One of the ways you can answer that question is by finding your basal metabolic rate (BMR); this is the number of calories you need per day to maintain weight. For males, the BMR is defined as follows: Multiply your body weight W (in pounds) by 10 and add double the body weight to the value.

- Write a formula for the BMR of a male.
- A male needed 1800 calories per day to maintain his weight. What was his weight?



44. BMR for adult females The BMR for females is different than for males. To find the BMR for a female multiply her body weight W (in pounds) by 10 and add the body weight to the value.

- Write a formula for the BMR of a female.
- A female needed 1320 calories per day to maintain her weight. What was her weight?

45. Exercise and weight loss One way to lose weight is to exercise! Physical activity contributes 20% to 30% of the body's total energy output. If you burn 700 calories through exercise and this represents 20% of your caloric output O for a week:

- Write an equation for the caloric output O for the week.
- What is your caloric output O for the week?
- To lose one pound, you need to burn 3500 calories. If your caloric output is as in part **b**, how many pounds would you lose that week?

46. Caloric output for different activities and weights Suppose you weigh 150 pounds.

Activity (one hour)	100 lb	150 lb	200 lb
Bicycling, 6 mph	160	240	312
Bicycling, 12 mph	270	410	534
Jogging, 7 mph	610	920	1230

- Write a formula for the number of calories C you will use in h hours of bicycling at 6 mph.
- Use the formula to find the number of calories C you will use in 3 hours of bicycling at 6 mph.
- A person used 1230 calories bicycling at 12 mph. Consult the chart, write an equation for the number of calories used in bicycling for h hours, and find out how many hours the person bicycled.



- 47. Caloric output for jogging** Suppose you weigh 150 pounds.
- Write a formula for the number of calories C you will use in h hours of jogging at 7 mph.
 - Use the formula to find the number of calories C you will use in 3 hours of jogging at 7 mph. Relax; you don't have to do it all at once!
 - Who will burn more calories jogging at 7 mph: a 100-pound person jogging for 3 hours or a 150-pound person jogging at 7 mph for 2 hours?
- 48. Caloric requirements** A simpler way to estimate the daily caloric requirements you need to maintain your weight is to use these formulas:
- For sedentary people: $S = 14W$, where W is your weight in pounds
- For moderately active people: $M = 17W$, where W is your weight in pounds
- For active people: $A = 20W$, where W is your weight in pounds
- Find the caloric requirements for a 140-pound person who is
- Sedentary
 - Moderately active
 - Active
- 49. Weight** A person is consuming 2380 calories a day. Refer to the formulas in Problem 48 and find the person's weight if the person is
- Sedentary
 - Moderately active
 - Active
- 50. Weight** The recommended number of daily calories to maintain weight for a 50+-year-old male is 2300. The recommended weight for an average height 50-year-old is 150 pounds. Which of the three categories of Problem 48 (S , M , or A) can this 50+-year-old be and still maintain his weight?

Problems 51 and 52 are based on "Your Weight on Other Worlds."

Source: <http://www.exploratorium.edu>.

- 51. Weight** Do you want to lose weight instantly and without dieting? Move to Pluto! Your weight P on Pluto is only 0.067 of your weight E on Earth.
- Write a formula for your weight P on Pluto.
 - If you weigh 150 pounds on Earth, how much do you weigh on Pluto?
 - If you weigh 9.38 pounds on Pluto, how much do you weigh on Earth?
- 52. Weight** If you want to *gain* weight instantly move to Jupiter. Your weight J on Jupiter will be 253.3 times your weight E on Earth.
- Write a formula for your weight J on Jupiter.
 - If you weigh 150 pounds on Earth, how much would you weigh on Jupiter?
 - If you weigh 40,528 pounds on Jupiter, how much do you weigh on Earth?

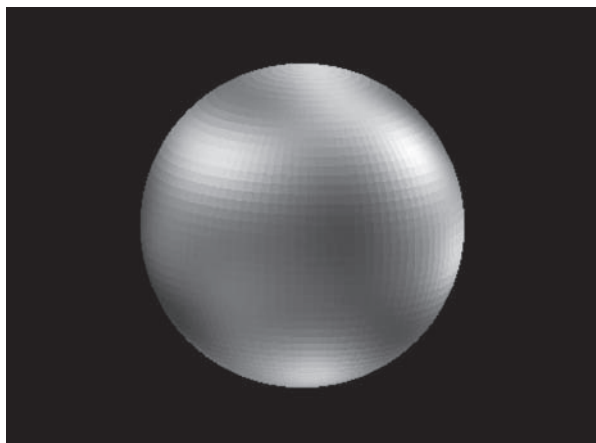

To check the answers to Problems 51 and 52, or if you want to know how much you weigh on many other planets, you can go to the website: <http://www.exploratorium.edu>.

Problems 53–56 are based on the Agriculture Fact Book: Profiling Food Consumption in America.

Source: <http://www.usda.gov>.

- 53. Available calories per person per day** How many calories C are available per person per day? According to the U.S. Department of Agriculture the answer is 3800 but 1100 of these calories are lost to spoilage, place waste, and cooking, leaving 2700 calories daily for each American. The approximate number of calories C is given by the formula:

$$C = 18t + 2170, \text{ where } t \text{ is the number of years after 1970.}$$

- How many calories per person per day were available in 1970 ($t = 0$)?
 - How many calories per person per day were available in 2000 ($t = 30$)?
 - Use the formula to predict how many calories per person per day would be available in 2020 ($t = 50$).
- 54. Predicting available calories** Use the formula $C = 18t + 2170$ of Problem 53 to find:
- How many years will it take to reach $C = 3000$ calories per person/day? Answer to the nearest whole number.
 - In what year will this happen?
- 56. Food consumption** In Problem 55 we used the formula $P = -0.07t + 3.3$, where t is the number of years after 1970 to predict the consumption of veal and lamb.
- Predict (to the nearest whole number) how many years it would take for P to be 0.
 - Based on your answer to part a, can you use the formula for $t \geq 47$?
Try it for $t = 50$!



- 55. Food consumption** Which types of food consumption are declining? Veal and lamb, for example. The formula for the annual number of pounds P of veal and lamb consumed per capita is given by the equation

$$P = -0.07t + 3.3, \text{ where } t \text{ is the number of years after 1970}$$

- What was the annual per capita consumption of veal and lamb in 1970?
- What would be the annual consumption of veal and lamb in 2010?
See the decline!

Applications: Green Math

Problems 57 and 58 are based on *Vital Signs 2006–2007*, Worldwatch Institute.

- 57. Biodiesels** Biodiesel is the name of a clean burning alternative fuel, produced from domestic, renewable resources. The production P (in millions of liters) can be approximated by
- $$P = 526.2t + 893, \text{ where } t \text{ is the number of years after 2000}$$
- Use the formula to find the biodiesel production in 2000 ($t = 0$).
 - Use the formula to find the biodiesel production in 2005 ($t = 5$).
 - Use the formula to predict the biodiesel production in 2010 ($t = 10$).

- 58. World population** Do you know the population of the world? You can go to the website and find out, but it is certainly over 6 billion and growing. Here is an approximation of the world population P (in billions):

The Population of the Earth is
6,528,777,630

Source: <http://opr.princeton.edu>.

$$P = 0.073t + 6.08, \text{ where } t \text{ is the number of years after 2000}$$

- Use the formula to predict the world population in 2010 ($t = 10$).
- Use the formula to predict how many years will it take for the world population to reach 7 billion. Answer to the nearest whole number.

Problems 59 and 60 are based on an Associated Press Report.

Source: The Associated Press; <http://www.msnbc.msn.com>.

- 59. U.S. population** The formula to estimate the U.S. population (in millions) is

$$P = 2.7t + 300, \text{ where } t \text{ is the number of years after 2006}$$

- Use the formula to predict the U.S. population (in millions) in 2010 ($t = 4$).
- In how many years (after 2006) will the U.S. population reach 500 million?
Answer to the nearest whole number.
- In what year will the population reach 500 million?

- 60. Ukraine population** Is there a place in the world where the population is decreasing? The answer is yes! Ukraine. (Look it up on a map and maybe you will see why!) The formula for the population P of Ukraine (in millions) is

$$P = -0.46t + 46, \text{ where } t \text{ is the number of years after 2006}$$

- Use the formula to predict the population of Ukraine in 2006 ($t = 0$).
- Use the formula to predict the number of years it will take for the population of Ukraine to be 0.
- Is this a realistic answer?

Using Your Knowledge

Oxidation Number Do you know why water is so common on Earth? It is because hydrogen and oxygen, the elements that compose water, are so common and they combine very easily. The number that indicates how an atom combines with other atoms in a compound is called the *valence*. (In modern chemistry books the term *valence* has been replaced by the term **oxidation number**.) For example, the formula for water is

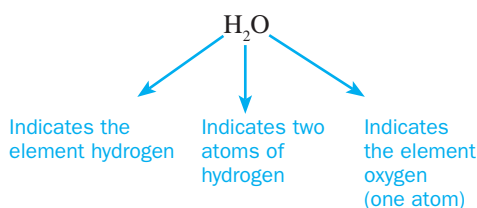

The valence of hydrogen is H and that of oxygen is -2 . Thus, if we have two hydrogen atoms and one oxygen atom, the valence of the compound is



Solving for H ,

$$H = +1$$

In Problems 61–64, assume that all compounds are stable.

- Find the valence of chromium (Cr) in sodium dichromate, $\text{Na}_2\text{Cr}_2\text{O}_7$, if the other valences are $\text{Na} = +1$ and $\text{O} = -2$.
- Find the valence of bromine (Br) in sodium bromate, NaBrO_3 , if the other valences are $\text{Na} = +1$ and $\text{O} = -2$.
- Find the valence of phosphorus (P) in phosphate, PO_4 , if the valence of oxygen is $\text{O} = -2$.
- Find the valence of nitrogen (N) in nitrate, NO_3 , if the valence of oxygen is $\text{O} = -2$.

Write On

- When reading a word problem, what is the first thing you try to determine?
- How do you verify your answer in a word problem?
- In Example 8, the information needed to solve the problem was there, but you had to dig for it. In real life, irrelevant information (called *red herrings*) may also be present. Find some problems with *red herrings* and point them out.

>>> Concept Checker

Fill in the blank(s) with the correct word(s), phrase, or mathematical statement.

68. The **procedure** used to **solve word problems** is called the _____ procedure.
69. In the **RSTUV** procedure, the **R** stands for _____.
70. In the **RSTUV** procedure, the **S** stands for _____.
71. In the **RSTUV** procedure, the **T** stands for _____.
72. In the **RSTUV** procedure, the **U** stands for _____.
73. In the **RSTUV** procedure, the **V** stands for _____.

Translate	RSTUV
Solving	Read
Recite	Select
Verify	Transpose
See	Use

>>> Mastery Test

74. A McDonald's cheeseburger and small fries contain 600 calories. If you double the number of calories in the fries, you get 90 more calories than in the cheeseburger. How many calories are in the cheeseburger and the fries?
75. If 12 is added to twice a number, the result is 5 times the number. Find the number.
76. Romualdo bought a 6-month, \$10,000 certificate of deposit. At the end of the 6 months, he received \$200 simple interest. What rate of interest did the certificate pay?
77. The cost of renting a car (in dollars) is \$30 plus \$0.25 per mile traveled. If the rental cost for one day amounts to \$110, how many miles were traveled?
78. Michael Hebranko decreased his weight by 900 pounds to a manageable 200 with the help of the Richard Simmons Program. How much did he weigh at the beginning of his diet? He has since regained most of the weight, and they had to remove a window to take him to the hospital!
79. A moon rock weighs 30 pounds on the moon. What would be its weight on Earth if objects weigh 6 times as much on Earth as they do on the moon?

> Collaborative Learning

Adapted from: The History of Algebra

<http://teacherexchange.mde.k12.ms.us/>, <http://www.algebra.com/algebra/about/history/>

Form three groups:

GROUP 1. Collect information about al-Khwarizmi.

GROUP 2. Create a timeline to show when the concepts used by al-Khwarizmi were developed in relation to other significant events in history.

GROUP 3. Find examples of the algebraic concepts developed by al-Khwarizmi.

Each group will go on a web quest to find the mathematicians that historians have named as being the *fathers or founders of algebra* and will prepare a written or electronic report to present to the class.

Each group will include: a Surfer, a Writer/Recorder, a Mathematician, and a Reporter.

Surfer—Surf the Internet using search engines. Work with the Recorder to research and record needed information for your topic.

Writer/Recorder—Record information on your topic and the URLs of websites where the information was found. Work with the Surfer and the Reporter to prepare (in hard copy and electronic formats) a report of the findings of your group.

Mathematician—Work with the Surfer and the Recorder to find sites that contain examples of mathematical problems from your assigned topic. Choose two examples from the Internet that you can share with the class; then create a problem in which you can demonstrate the topic for the class.

Reporter—Work with the other members of your group to create a presentation, using computer software or traditional hard copies, which you will present to the class. ■

Research Questions

1. Find out more about al-Khwarizmi (for example, his exact birthplace and date of birth) and write a few paragraphs about him and his life. Include the titles of the books he wrote and the types of problems appearing in these books.
2. A Latin corruption of *al-Khwarizmi* was interpreted as “the art of computing with Hindu-Arabic numerals.” What modern concept is derived from the word, and what does the concept mean in mathematics?
3. Another translation of the word *jabr* is “the setting of broken bones.” Write a paragraph detailing how the word reached Spain as *algebra* and the context in which the word was used.
4. In his book, al-Khwarizmi mentioned six types of equations that can be written using squares, square roots, and constants. What are the six types of equations?
5. Al-Khwarizmi’s work was continued in the Islamic world. In the first decade of the eleventh century, a major book dealing with algebra entitled *The Marvelous* was written. Who was the author of this book, what was its original title, and what topics were covered in the book?

Summary Chapter 10

Section	Item	Meaning	Example
10.1	Placeholders (variables or unknowns)	Letters used in place of numbers	In $x + 4 = 7$, x is the placeholder, variable, or unknown.
10.1A	Expression	A collection of numbers and letters connected by operation signs	$xy^2 + 2x + 3$ is an expression.
10.1B	Distributive property	$a(b + c) = ab + ac$	$3(x + 5) = 3x + 15$
10.1C	Factoring	$ax + bx = (a + b)x$	$3x + 6y = 3(x + 2y)$
10.1E	Removing parentheses	$-(a - b) = -a + b$	$-(2x - 5) = -2x + 5$
10.2A	Integer exponents	$x^{-n} = \frac{1}{x^n}$, n an integer, $x \neq 0$	$3^{-2} = \frac{1}{3^2}$ and $x^{-5} = \frac{1}{x^5}$
10.2B	Product rule of exponents	$x^m \cdot x^n = x^{m+n}$, m and n integers, $x \neq 0$	$x^5 \cdot x^3 = x^{5+3} = x^8$
10.2C	Quotient rule of exponents	$\frac{x^m}{x^n} = x^{m-n}$, m and n integers, $x \neq 0$	$\frac{x^7}{x^3} = x^{7-3} = x^4$
10.2D	Power rule of exponents Product to a power rule of exponents	$(x^m)^n = x^{mn}$, m and n integers, $x \neq 0$ $(x^m y^n)^k = x^{mk} y^{nk}$ m, n, k integers, $x, y \neq 0$	$(x^{-2})^3 = x^{-2 \cdot 3} = x^{-6} = \frac{1}{x^6}$ $(x^3 y^{-4})^5 = x^{15} y^{-20} = \frac{x^{15}}{y^{20}}$

Section	Item	Meaning	Example
10.2E	Compound interest	$A = P(1 + r)^n$, where A is the amount after n years of a principal P invested at rate r compounded annually	If $P = \$1000$ is invested for $n = 3$ years at a rate of $r = 6\% = 0.06$, the amount is $A = 1000(1 + 0.06)^3$.
10.3A	Scientific notation	A number is in scientific notation when written as $M \times 10^n$, M between 1 and 10, n an integer.	6.27×10^{-4} is in scientific notation.
10.4A	Linear equation	An equation in which the variable occurs only to the first degree	$x + 7 = 2x - 9$ is a linear equation.
10.4B	Procedure for solving linear equations	<ol style="list-style-type: none"> 1. Simplify the equation if necessary. 2. Add or subtract the same numbers to or from both sides so that one side contains variables only. 3. Add or subtract the same expressions to or from both sides so that the other side contains numbers only. 4. If the coefficient of the variable (the number that multiplies the variable) is not 1, divide both sides by this number. 5. The resulting number is the solution of the equation. Check in the original equation to be sure it is correct. 	
10.5A	Procedure for solving word problems	<p>Read the problem.</p> <p>Select the unknown.</p> <p>Translate the problem.</p> <p>Use algebra to solve the equation.</p> <p>Verify your answer.</p>	

Review Exercises Chapter 10

(If you need help with these exercises, look in the section indicated in brackets.)

- 1.** **<10.1A>** List the terms in the expression.

 - a. $6x^3 - 3x^2 + 7x - 7$
 - b. $5x^3 - 4x^2 + 6x - 6$
 - c. $4x^3 - 5x^2 + 5x - 5$
 - d. $3x^3 - 6x^2 + 4x - 4$
 - e. $2x^3 - 7x^2 + 3x - 3$
- 2.** **<10.1B>** Multiply.

 - a. $2(x + 2y)$
 - b. $3(x + 2y)$
 - c. $4(x + 2y)$
 - d. $5(x + 2y)$
 - e. $6(x + 2y)$
- 3.** **<10.1B>** Multiply.

 - a. $-4(x - 2y + z)$
 - b. $-5(x - 2y + z)$
 - c. $-6(x - 2y + z)$
 - d. $-7(x - 2y + z)$
 - e. $-8(x - 2y + z)$

4. **<10.1C>** Factor.
- $3x - 12y$
 - $3x - 15y$
 - $3x - 18y$
 - $3x - 21y$
 - $3x - 24y$
5. **<10.1C>** Factor.
- $40x - 50y - 60z$
 - $30x - 40y - 50z$
 - $20x - 30y - 40z$
 - $10x - 20y - 30z$
 - $10x - 10y - 20z$
6. **<10.1D>** Combine like terms (simplify).
- $3x + 5y - x + 4y$
 - $4x + 5y - x + 3y$
 - $5x + 5y - x + 2y$
 - $6x + 5y - 2x + 4y$
 - $7x + 5y - 3x + 4y$
7. **<10.1D>** Combine like terms (simplify).
- $0.3x + 0.31y - 0.5x + 0.23y$
 - $0.3x + 0.32y - 0.6x + 0.23y$
 - $0.3x + 0.33y - 0.7x + 0.23y$
 - $0.3x + 0.34y - 0.8x + 0.23y$
 - $0.3x + 0.35y - 0.9x + 0.23y$
8. **<10.1D>** Combine like terms (simplify).
- $\frac{1}{11}x + \frac{9}{13}y + \frac{3}{11}x - \frac{2}{13}y$
 - $\frac{2}{11}x + \frac{8}{13}y + \frac{3}{11}x - \frac{2}{13}y$
 - $\frac{3}{11}x + \frac{7}{13}y + \frac{3}{11}x - \frac{2}{13}y$
 - $\frac{4}{11}x + \frac{6}{13}y + \frac{3}{11}x - \frac{2}{13}y$
 - $\frac{5}{11}x + \frac{5}{13}y + \frac{3}{11}x - \frac{2}{13}y$
9. **<10.1E>** Simplify.
- $(4a + 5b) - (a + 2b)$
 - $(5a + 5b) - (a + 2b)$
 - $(6a + 5b) - (a - 2b)$
 - $(7a + 5b) - (-a + 2b)$
 - $(8a + 5b) - (a - 3b)$
10. **<10.2A>** Write with positive exponents and simplify.
- 2^{-2}
 - 2^{-3}
 - 2^{-4}
 - 2^{-5}
 - 2^{-6}
11. **<10.2A>** Write using negative exponents.
- $\frac{1}{2^3}$
 - $\frac{1}{2^4}$
 - $\frac{1}{2^5}$
 - $\frac{1}{2^6}$
 - $\frac{1}{2^7}$
12. **<10.2B>** Multiply and simplify.
- $x^3 \cdot x^4$
 - $x^3 \cdot x^5$
 - $x^3 \cdot x^6$
 - $x^3 \cdot x^7$
 - $x^3 \cdot x^8$
13. **<10.2B>** Multiply and simplify.
- $2^3 \cdot 2^{-5}$
 - $2^3 \cdot 2^{-6}$
 - $2^3 \cdot 2^{-7}$
 - $2^3 \cdot 2^{-8}$
 - $2^3 \cdot 2^{-9}$
14. **<10.2B>** Multiply and simplify.
- $y^3 \cdot y^{-5}$
 - $y^3 \cdot y^{-6}$
 - $y^3 \cdot y^{-7}$
 - $y^3 \cdot y^{-8}$
 - $y^3 \cdot y^{-9}$
15. **<10.2C>** Divide and simplify.
- $\frac{2^4}{2^{-2}}$
 - $\frac{2^5}{2^{-2}}$
 - $\frac{2^6}{2^{-2}}$
 - $\frac{2^7}{2^{-2}}$
 - $\frac{2^8}{2^{-2}}$
16. **<10.2C>** Divide and simplify.
- $\frac{x^2}{x^5}$
 - $\frac{x^2}{x^6}$
 - $\frac{x^2}{x^7}$
 - $\frac{x^2}{x^8}$
 - $\frac{x^2}{x^9}$
17. **<10.2C>** Divide and simplify.
- $\frac{y^{-2}}{y^{-4}}$
 - $\frac{y^{-2}}{y^{-5}}$
 - $\frac{y^{-2}}{y^{-6}}$
 - $\frac{y^{-2}}{y^{-7}}$
 - $\frac{y^{-2}}{y^{-8}}$
18. **<10.2D>** Simplify.
- $(2^2)^1$
 - $(2^2)^2$
 - $(2^2)^3$
 - $(2^2)^4$
 - $(2^2)^5$

19. <10.2D> Simplify.

- a. $(y^4)^{-2}$ b. $(y^4)^{-3}$
 c. $(y^4)^{-4}$ d. $(y^4)^{-5}$
 e. $(y^4)^{-6}$

22. <10.2D> Simplify.

- a. $(x^{-2}y^3)^{-2}$
 b. $(x^{-2}y^3)^{-3}$
 c. $(x^{-2}y^3)^{-4}$
 d. $(x^{-2}y^3)^{-5}$
 e. $(x^{-2}y^3)^{-6}$

25. <10.3A> Write in standard notation.

- a. 7.83×10^3
 b. 6.83×10^4
 c. 5.83×10^5
 d. 4.83×10^6
 e. 3.83×10^7

28. <10.3B> Perform the indicated operations and write the answer in scientific notation.

- a. $(1.1 \times 10^3) \times (2 \times 10^{-5})$
 b. $(1.1 \times 10^4) \times (3 \times 10^{-5})$
 c. $(1.1 \times 10^3) \times (4 \times 10^{-6})$
 d. $(1.1 \times 10^3) \times (5 \times 10^{-7})$
 e. $(1.1 \times 10^4) \times (6 \times 10^{-8})$

31. <10.4A> Solve.

- a. $\frac{-y}{3} = 2$
 b. $\frac{-y}{3} = 3$
 c. $\frac{-y}{3} = 4$
 d. $\frac{-y}{3} = 5$
 e. $\frac{-y}{3} = 6$

20. <10.2D> Simplify.

- a. $(z^{-3})^{-2}$ b. $(z^{-3})^{-3}$
 c. $(z^{-3})^{-4}$ d. $(z^{-3})^{-5}$
 e. $(z^{-3})^{-6}$

23. <10.3A> Write in scientific notation.

- a. 44,000,000
 b. 450,000,000
 c. 4,600,000
 d. 47,000
 e. 48,000,000

26. <10.3A> Write in standard notation.

- a. 8.4×10^{-2}
 b. 7.4×10^{-3}
 c. 6.4×10^{-4}
 d. 5.4×10^{-5}
 e. 4.4×10^{-6}

29. <10.3B> Perform the indicated operations and write the answer in scientific notation.

- a. $(1.15 \times 10^{-3}) \div (2.3 \times 10^{-4})$
 b. $(1.38 \times 10^{-2}) \div (2.3 \times 10^{-4})$
 c. $(1.61 \times 10^{-3}) \div (2.3 \times 10^{-5})$
 d. $(1.84 \times 10^{-4}) \div (2.3 \times 10^{-4})$
 e. $(2.07 \times 10^{-3}) \div (2.3 \times 10^{-4})$

32. <10.4A> Solve.

- a. $-1.2z = 2.4$
 b. $-1.2z = 3.6$
 c. $-1.2z = 4.8$
 d. $-1.2z = 7.2$
 e. $-1.2z = 8.4$

21. <10.2D> Simplify.

- a. $(x^3y^{-2})^2$ b. $(x^3y^{-2})^3$
 c. $(x^3y^{-2})^4$ d. $(x^3y^{-2})^5$
 e. $(x^3y^{-2})^6$

24. <10.3A> Write in scientific notation.

- a. 0.0014
 b. 0.00015
 c. 0.000016
 d. 0.0000017
 e. 0.00000018

27. <10.3B> Perform the indicated operations and write the answer in scientific notation.

- a. $(2 \times 10^2) \times (1.1 \times 10^3)$
 b. $(3 \times 10^2) \times (3.1 \times 10^4)$
 c. $(4 \times 10^3) \times (3.1 \times 10^5)$
 d. $(5 \times 10^2) \times (3.1 \times 10^6)$
 e. $(6 \times 10^2) \times (3.1 \times 10^6)$

30. <10.4A> Solve.

- a. $y + \frac{1}{3} = \frac{1}{2}$
 b. $y + \frac{1}{4} = \frac{1}{2}$
 c. $y + \frac{1}{5} = \frac{1}{2}$
 d. $y + \frac{1}{6} = \frac{1}{2}$
 e. $y + \frac{1}{7} = \frac{1}{2}$

33. <10.4B> Solve.

- a. $-3x + 5 = 10$
 b. $-3x + 5 = 13$
 c. $-3x + 5 = 15$
 d. $-3x + 5 = 18$
 e. $-3x + 5 = 21$

34. <10.4B> Solve.

- a. $2x - 6 = 10$
- b. $2x - 6 = 12$
- c. $2x - 6 = 14$
- d. $2x - 6 = 16$
- e. $2x - 6 = 18$

37. <10.4B> Solve.

- a. $\frac{2}{7}x = -3$
- b. $\frac{2}{7}x = -5$
- c. $\frac{2}{7}x = -7$
- d. $\frac{2}{7}x = -9$
- e. $\frac{2}{7}x = -11$

39. <10.5A> The daily cost C of renting a car is \$30 plus \$0.20 per mile traveled. If m is the number of miles traveled, then $C = 30 + 0.20m$. Find the number m of miles traveled if a day's rental amounted to:

- a. \$70.40
- b. \$70.60
- c. \$70.80
- d. \$71.20
- e. \$71.40

35. <10.4B> Solve.

- a. $4x + 5.4 = 2x + 9.6$
- b. $5x + 5.4 = 3x + 9.6$
- c. $6x + 5.4 = 4x + 9.6$
- d. $7x + 5.4 = 5x + 9.6$
- e. $8x + 5.4 = 6x + 9.6$

38. <10.4B> Solve.

- a. $\frac{1}{4}x - \frac{3}{8} + \frac{3}{2}x = \frac{1}{4} + 2x$
- b. $\frac{1}{4}x - \frac{3}{8} + \frac{5}{2}x = \frac{1}{4} + 3x$
- c. $\frac{1}{4}x - \frac{3}{8} + \frac{7}{2}x = \frac{1}{4} + 4x$
- d. $\frac{1}{4}x - \frac{3}{8} + \frac{9}{2}x = \frac{1}{4} + 5x$
- e. $\frac{1}{4}x - \frac{3}{8} + \frac{11}{2}x = \frac{1}{4} + 6x$

36. <10.4B> Solve.

- a. $36 = 3(x + 1)$
- b. $27 = 3(x + 1)$
- c. $24 = 3(x + 1)$
- d. $21 = 3(x + 1)$
- e. $18 = 3(x + 1)$

40. <10.5A> An investor bought a 6-month, \$1000 certificate of deposit. What rate of interest did the certificate pay if at the end of the 6 months the interest the investor received was:

- a. \$30
- b. \$40
- c. \$50
- d. \$60
- e. \$70

> Practice Test Chapter 10

(Answers on page 664)

Visit www.mhhe.com/bello to view helpful videos that provide step-by-step solutions to several of the problems below.

1. List the terms in the expression $6x^3 - 3x^2 + 8x - 9$.
2. Multiply.
 - a. $3(x + 2y)$
 - b. $-4(x - 2y + z)$
3. Factor.
 - a. $4x - 8y$
 - b. $30x - 40y - 50z$
4. Combine like terms (simplify).
 - a. $4x + 6y - x + 4y$
 - b. $\frac{2}{7}x + \frac{4}{5}y + \frac{3}{7}x - \frac{3}{5}y$
5. Simplify: $(4a + 5b) - (a + 2b)$.
6. Write as a fraction with positive exponents and simplify: 3^{-4} .
7. Multiply and simplify.
 - a. $x^2 \cdot x^6$
 - b. $4^3 \cdot 4^{-6}$
 - c. $y^3 \cdot y^{-6}$
8. Divide and simplify.
 - a. $\frac{2^4}{2^{-2}}$
 - b. $\frac{x^3}{x^7}$
 - c. $\frac{y^{-3}}{y^{-6}}$
9. Simplify.
 - a. $(2^2)^4$
 - b. $(y^4)^{-4}$
 - c. $(z^{-3})^{-3}$
10. Simplify.
 - a. $(x^4y^{-2})^3$
 - b. $(x^{-3}y^4)^{-3}$
11. Write in scientific notation.
 - a. 88,000,000
 - b. 0.0000013
12. Write in standard notation.
 - a. 6.57×10^4
 - b. 9.4×10^{-3}
13. Perform the indicated operations and write the answer in scientific notation.
 - a. $(3 \times 10^2) \times (7.1 \times 10^3)$
 - b. $(3.1 \times 10^3) \times (3 \times 10^{-6})$
 - c. $(1.84 \times 10^{-3}) \div (2.3 \times 10^{-4})$
14. Solve.
 - a. $y + \frac{3}{8} = \frac{3}{4}$
 - b. $\frac{-y}{2} = 6$
 - c. $-1.8z = 5.4$
15. Solve.
 - a. $-4x + 9 = 14$
 - b. $2x - 6 = 12$
16. Solve.
 - a. $3x + 4.4 = x + 8.6$
 - b. $4(x + 1) = 2x + 12$
17. Solve.
 - a. $12 = 3(x + 1)$
 - b. $\frac{3}{5}x = -5$
18. Solve. $\frac{1}{4}x - \frac{1}{8} + \frac{1}{2}x = \frac{1}{2} + x$
19. The daily cost C of renting a car is \$30 plus \$0.20 per mile traveled. If m is the number of miles traveled, then $C = 30 + 0.20m$. If a person paid \$70.60 for a day's rental, how many miles did this person travel?
20. Toni bought a 6-month, \$1000 certificate of deposit. At the end of the 6 months, she received \$50 simple interest. What rate of interest did the certificate pay?

Answers to Practice Test Chapter 10

Answer	If You Missed		Review	
	Question	Section	Examples	Page
1. $6x^3; -3x^2; 8x; -9$	1	10.1	1	608
2. a. $3x + 6y$ b. $-4x + 8y - 4z$	2	10.1	2	609
3. a. $4(x - 2y)$ b. $10(3x - 4y - 5z)$	3	10.1	3	609–610
4. a. $3x + 10y$ b. $\frac{5}{7}x + \frac{1}{5}y$	4	10.1	4	610
5. $3a + 3b$	5	10.1	5, 6	611–612
6. $\frac{1}{3^4} = \frac{1}{81}$	6	10.2	1	620
7. a. x^8 b. $4^{-3} = \frac{1}{64}$ c. $\frac{1}{y^3}$	7	10.2	3	621
8. a. $2^6 = 64$ b. $\frac{1}{x^4}$ c. y^3	8	10.2	4	622
9. a. $2^8 = 256$ b. $\frac{1}{y^{16}}$ c. z^9	9	10.2	5	623
10. a. $\frac{x^{12}}{y^6}$ b. $\frac{x^9}{y^{12}}$	10	10.2	6	623–624
11. a. 8.8×10^7 b. 1.3×10^{-6}	11	10.3	1	629
12. a. 65,700 b. 0.0094	12	10.3	2	629
13. a. 2.13×10^6 b. 9.3×10^{-3} c. 8×10^0 or 8	13	10.3	3, 4	630
14. a. $y = \frac{3}{8}$ b. $y = -12$ c. $z = -3$	14	10.4	1, 2	635–636
15. a. $x = -\frac{5}{4}$ b. $x = 9$	15	10.4	3, 4	637–638
16. a. $x = 2.1$ b. $x = 4$	16	10.4	5, 6, 7	638–639
17. a. $x = 3$ b. $x = -\frac{25}{3}$	17	10.4	5, 6, 7	638–639
18. $x = -\frac{5}{2}$	18	10.4	8	639–640
19. 203	19	10.5	1–4	645–647
20. 10%	20	10.5	5	647

> Cumulative Review Chapters 1–10

1. Simplify: $49 \div 7 \cdot 7 + 8 - 5$
2. Divide: $80 \div 0.13$ (Round answer to two decimal digits.)
3. Write 23% as a decimal.
4. 90% of 40 is what number?
5. What percent of 8 is 4?
6. 6 is 30% of what number?
7. Find the simple interest earned on \$300 invested at 7.5% for 5 years.
8. The following table shows the distribution of families by income in Portland, Oregon.
9. The number of hours required in each discipline of a college core curriculum is represented by the following circle graph. What percent of these hours is in art and math combined?

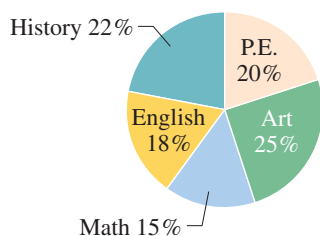

10. What is the mode of the following numbers?
10, 5, 5, 12, 5, 7, 23, 24, 5, 5, 9

Income Level	Percent of Families
\$0–9999	3
10,000–14,999	8
15,000–19,999	26
20,000–24,999	34
25,000–34,999	11
35,000–49,999	9
50,000–79,999	5
80,000–119,999	3
120,000 and over	1

What percent of the families in Portland have incomes of \$120,000 and over?

11. What is the mean of the following numbers?
2, 16, 1, 28, 1, 30, 1, 25
12. What is the median of the following numbers?
9, 5, 6, 10, 29, 7, 14, 14, 14
13. Convert 4 yards to inches.
14. Convert 17 inches to feet.
15. Convert 17 feet to yards.
16. Convert 7 feet to inches.
17. Convert 240 meters to decimeters.
18. Find the perimeter of a rectangle 4.8 centimeters long by 2.8 centimeters wide.
19. Find the circumference of a circle whose radius is 9 in. (Use 3.14 for π .)
20. Find the area of a triangular piece of cloth that has a 10-centimeter base and is 16 centimeters high.
21. Find the area of a circle with a radius of 3 centimeters. (Use 3.14 for π .)
22. Find the volume of a box 7 centimeters wide, 5 centimeters long, and 3 centimeters high.
23. Find the volume of a sphere with a 12-inch radius. Use 3.14 for π and give the answer to two decimal places.
24. Classify the angle.
25. If in triangle ABC , $m\angle A = 35^\circ$ and $m\angle B = 25^\circ$, what is $m\angle C$?
26. Find $\sqrt{8100}$.

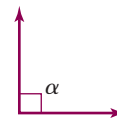

27. Find the hypotenuse h of the given triangle.

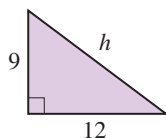

28. Find the additive inverse (opposite) of $-3\frac{4}{5}$.

29. Find: $|-3.5|$
31. Add: $\frac{2}{5} + \left(-\frac{1}{8}\right)$
33. Subtract: $-\frac{2}{5} - \frac{2}{7}$
35. Divide: $-\frac{10}{7} \div \frac{3}{7}$
37. Multiply: $5(4x - 8y)$
39. Simplify: $(2x + y) - (7x - 2y)$
41. Multiply and simplify: $x^{-2} \cdot x^{-5}$
43. Write in scientific notation: 0.000000024
45. Divide and express the answer in scientific notation:
 $(2.695 \times 10^{-3}) \div (7.7 \times 10^4)$
47. Solve for x : $9x - 10 = 8$
49. Solve for x : $16 = 4(x - 9)$
30. Add: $-4.7 + (-6.8)$
32. Subtract: $-3.8 - (-4.1)$
34. Multiply: $-\frac{7}{8} \cdot \frac{9}{7}$
36. Evaluate: $(-7)^2$
38. Factor: $60x - 30y - 40z$
40. Write as a fraction with positive exponents and simplify 9^{-2} .
42. Simplify: $(3x^3y^{-2})^2$
44. Write in standard notation: 2.82×10^7
46. Solve for x : $\frac{5}{7}x = -35$
48. Solve for x : $2x - 4 = x + 3$

The brackets preceding answers for the Chapter Review Exercises indicate the Chapter, Section, and Objective for you to review for further study. For example, [3.4C] appearing before answers means those exercises correspond to Chapter 3, Section 4, Objective C.

Chapter 1

Exercises 1.1

1. 2 3. 800 5. 40 7. 40 9. Tens 11. Ones (Units)
 13. Ones (Units) 15. Hundreds 17. $30 + 4$ 19. $100 + 8$
 21. $2000 + 500$ 23. $7000 + 40$ 25. $20,000 + 3000 + 10 + 8$
 27. $600,000 + 4000$ 29. $90,000 + 1000 + 300 + 80 + 7$
 31. $60,000 + 8000 + 20$ 33. $80,000 + 80 + 2$ 35. $70,000 + 100 + 90 + 8$ 37. 78 39. 308 41. 822 43. 701 45. 3473
 47. 5250 49. 2030 51. 8090 53. 7001 55. 6600 57. Fifty-seven
 59. Three thousand four hundred eight 61. One hundred eighty-one thousand, three hundred sixty-two 63. Forty-one million, three hundred thousand 65. One billion, two hundred thirty-one million, three hundred forty-one thousand 67. 809 69. 4897
 71. 2003 73. 2,023,045 75. 345,033,894 77. One hundred seventy-three thousand, eight hundred eighty 79. Thirteen million, five hundred thirty-seven thousand 81. 14,979,000 83. 6 85. 4
 87. 100 89. 2 91. 25 93. Fifteen 95. Eighty 97. Two thousand five hundred 99. 50,000,000 101. 1,000,000,000 103. 5182 kilowatt-hours 105. 7001 kilowatt-hours 107. 9799.00
 109. Twenty-eight thousand, nine hundred 111. Ninety thousand, eight hundred 115. 8 117. Seven 119. whole 121. natural
 123. numeral 125. Twelve thousand, eight hundred forty-nine
 127. Hundreds 129. Three hundred five

Exercises 1.2

1. < 3. > 5. < 7. > 9. < 11. 70 13. 90 15. 100
 17. 100 19. 400 21. 1000 23. 2000 25. 7000 27. 10,000
 29. 9000 31. 590; 600; 1000 33. 29,450; 29,500; 29,000
 35. 49,990; 50,000; 50,000 37. 259,910; 259,900; 260,000
 39. 289,000; 289,000; 289,000 41. 150 43. 1100 45. 11,000
 47. 7,900,000 49. \$86,000,000 51. (a) $\$689 < \$968 < \$1019$;
 (b) $\$1019 > \$968 > \$689$; (c) Dimension 8400; (d) Dimension E310
 53. (a) $90 < 96 < 141 < 167$; (b) $167 > 141 > 96 > 90$; (c) Do the laundry in cold water; (d) Replace regular lightbulbs 55. \$23,900
 57. \$349 59. \$25,676 63. left 65. place 67. add one
 69. (a) 770; (b) 360; (c) 900 71. \$50,000 73. Nine thousand, nine hundred ninety-five dollars 75. Ten thousand, five hundred forty-four dollars 77. Ten thousand, nine hundred ninety-five dollars

Exercises 1.3

1. 11 3. 11 5. 16 7. 30 9. 165 11. 129 13. 60 15. 11
 17. 34 19. 35 21. 23 23. 81 25. 127 27. 125 29. 132
 31. 152 33. 400 35. 6773 37. 1813 39. 3723 41. 4644
 43. 2340 45. 15,190 47. 91,275 49. 220,810 51. 582
 53. 64 55. 195 57. 1472 ft 59. 2280 61. \$306 63. \$167
 65. 360 ft 67. 1040 ft 69. 64 ft 71. \$483 73. Family A: \$620; Family B: \$1008 75. A = 10 (average); B = 18 (high); C = 6 (below average) 77. (a) Basic Cow, \$500; Shipping and handling, 36; Extra stomach, 79; Two-tone exterior, 142; Produce storage compartment, 127; Heavy-duty straw chopper, 190; 4 spigot/high output drain system, 149; Automatic fly swatter, 89; Genuine cowhide upholstery, 180; Deluxe dual horns, 59; Automatic fertilizer attachment, 339; 4 × 4 traction drive assembly, 884; Pre-delivery wash and comb (Farmer Prep), 70; Additional Farmer Markup and hay fees, 300; (b) \$2843.36; \$2844; (c) \$3143.36; (d) 4 × 4 traction drive assembly (\$884.16); (e) Shipping and handling (\$35.75)

79. (a) 74 mi; (b) 337 mi; (c) via Salinas, Paso Robles, and Bakersfield 81. 482 mi 87. (a) 0; (b) 0; (c) The identity for addition. 89. addends 91. 0 93. Perimeter 95. 25,549
 97. 1347 99. \$9000; the exact answer is \$8988 101. One thousand forty; Two hundred twenty-five; Seventy-two

Exercises 1.4

1. 8 3. 7 5. 17 7. 8 9. 34 11. 63 13. 34 15. 15
 17. 212 19. 79 21. 407 23. 215 25. 282 27. 179
 29. 209 31. 2621 33. 3505 35. 4088 37. 2893 39. 889
 41. 7246 43. 4291 45. 5714 47. 5880 49. 26,431 51. 1467 ft
 53. 4 55. 2019 ft 57. \$201 59. \$1013 61. \$12,445
 63. (a) \$18,975; (b) \$3025 65. \$51 67. \$279 69. \$330
 71. Bachelor's degree 73. 33 75. \$152,000 77. \$3300
 79. \$19,044 81. 210 83. 122 85. 79°F 87. 332°F 89. 358°F
 95. minus 97. $a = c + b$ 99. inverse 101. 795 103. 446
 105. \$288 107. 5745 109. $2000 + 300 + 40 + 8$

Exercises 1.5

1. (a) 12; (b) 21 3. (a) 9; (b) 8 5. (a) 40; (b) 72 7. (a-b) 0
 9. (a) 8; (b) 4 11. 48 13. 5 15. 81 17. 0 19. 16 21. 90
 23. 160 25. 318 27. 816 29. 19,456 31. 3702 33. 563,344
 35. 2520 37. 12,450 39. 145,320 41. 452,000 43. 1,223,100
 45. 100 47. 56,000 49. 60,000 51. 200 ft 53. (a) 6,000,000 km;
 (b) 7,500,000 km; (c) 9,000,000 km 55. \$9888 57. (a) 260;
 (b) 520 59. 64 billion barrels 61. 300 ft² 63. 8100 ft²
 65. 57,600 ft² 67. 2,100,000,000 trees (2 billion, 100 million trees)
 69. 1825 gallons 71. 1,250,000 gallons 73. 494 75. \$4600;
 21,850 77. 158 lb 79. (a) 2250; (b) 2550 85. $a \cdot b$, $a \times b$, and
 (a) (b) 87. factors 89. 1 91. $a \cdot (b \cdot c)$ 93. 12,600 95. 143,550
 97. 41,022 99. 392 101. 30 103. $200 + 30 + 4$ 105. 1135
 107. 2772

Exercises 1.6

1. 6 3. 7 5. 3 7. 0 9. 1 11. 4 13. not defined 15. 4
 17. 24 19. $10r^2$ 21. 61 23. 631 25. $513r^3$ 27. 24
 29. 21 31. $60r^5$ 33. 44 35. $9r^76$ 37. $42r^1$ 39. $59r^7$
 41. $214r^25$ 43. $45r^48$ 45. 87 47. 630 49. $934r^466$
 51. 504 53. 3 55. \$600 57. 1160 59. 300 61. \$114
 63. \$638 65. 600 67. (a) 2000; (b) 200 69. \$52,500
 71. \$37,500 73. \$25,000 75. \$225 77. \$25 83. $a = b \times c$
 85. inverse 87. a 89. (a) $48 = 6 \times \square$; 8; (b) $37 = 1 \times \square$; 37
 91. (a) $9 = 9 \times \square$; 1; (b) $7 = 1 \times \square$; 7 93. (a) 132; (b) 192
 95. < 97. 305,915

Exercises 1.7

1. prime 3. 1, 2, 3, 6 5. 1, 2, 3, 4, 6, 8, 12, 24 7. 1, 5, 25
 9. prime 11. 2, 7 13. 2, 3 15. 29 17. 2, 11 19. 3, 7
 21. 2×17 23. prime 25. 2⁶ 27. 7×13 29. $2 \times 5 \times 19$
 31. 4 33. 1 35. 100 37. 128 39. 200 41. 15 43. 2×10^9
 45. $2^4 = 16$; $2^5 = 32$ 47. 10^9 49. 30,000 51. 1,500,000 53. 100
 55. 500,000,000,000; 500 billion 57. 40,000; forty thousand
 59. 20,000; twenty thousand 61. (a) Yes; (b) No; (c) Yes
 63. (a) Yes; (b) No; (c) Yes 65. (a) Yes; (b) Yes; (c) No; (d) Yes
 67. (a) Yes; (b) No; (c) Yes; (d) No 69. (a) Yes; (b) No; (c) No;
 (d) Yes 75. sum 77. even 79. 1 81. (a) prime; (b) composite
 83. (a) $2^4 \times 3^2 \times 5^2$; (b) $2^3 \times 3^2 \times 5$ 85. 100 87. $1 \times 10^2 + 3 \times 10 + 8$ 89. $1 \times 10^3 + 2 \times 10^2 + 8$

Exercises 1.8

1. 26 3. 13 5. 53 7. 5 9. 3 11. 10 13. 21 15. 18 17. 8
 19. 10 21. 10 23. 20 25. 27 27. (a) $3 \times 10 + 2$; (b) \$32
 29. 26% 31. 45% 33. 89% 35. 43% 37. 20% 39. 13%
 41. 3.25 kg 43. 18 kg 45. (a) 20 kg; (b) $18.5 \text{ kg} \approx 19 \text{ kg}$
 47. 5 milligrams 49. 1 tablet every 12 hours 51. $(8 \div 2)(3 + 3)$
 53. $(8 \div 2)(9 - 3)$ 55. 4; 7 57. parentheses 59. multiplication
 61. addition 63. 16 65. 2 67. 84 69. 28 71. 144 73. Seven thousand, two hundred

Translate This

1. I 3. B 5. C 7. D 9. M

Exercises 1.9

1. $m = 8$ 3. $x = 4$ 5. $x = 5$ 7. $x = 6$ 9. $y = 5$ 11. $t = 7$
 13. $z = 48$ 15. $p = 52$ 17. $x = 14$ 19. $m = 13$ 21. $x = 7$
 23. $x = 4$ 25. 633 mi/hr 27. 37 miles 29. 15,000 lb 31. 150
 33. 280 35. Fries 210, cheeseburger 330 37. \$1572 39. Grants
 \$2000, scholarships \$1600 41. $1000 + 5p$; \$223 43. \$1212
 45. \$450 47. 158 49. (a) 52,500; (b) 500; (c) 105 51. Tip \$16,
 Meal \$80 53. 157 million TVs; 21 million computer units
 55. 157 million computer products; 126 million cell phones
 57. 66 million computers; 42 million monitors 59. Duct leak \$300;
 tune-up \$180 61. Geothermal \$30,000; cross ventilation \$1200
 63. 6 hours 67. 1; yes 69. solution 71. Addition 73. $a \div c =$
 $b \div c$; $c \neq 0$ 75. $x = 9$ 77. $x = 5$ 79. $m = 2$
 81. $x = 15$ 83. $x = 15$ 85. $9r + 2$

Review Exercises

1. [1.1A, B] (a) $100 + 20 + 7$; seven; (b) $100 + 80 + 9$; 80;
 (c) $300 + 80$; 300; (d) $1000 + 400 + 90$; 1000
 (e) $2000 + 500 + 50 + 9$; 2000 2. [1.1C] (a) 49; (b) 586;
 (c) 503; (d) 810; (e) 1004 3. [1.1D] (a) Seventy-nine;
 (b) One hundred forty-three; (c) One thousand, two hundred forty-
 nine; (d) Five thousand, six hundred fifty-nine; (e) Twelve thousand,
 three hundred forty-seven 4. [1.1E] (a) 26; (b) 192; (c) 468;
 (d) 1644; (e) 42,801 5. [1.2A] (a) $<$; (b) $>$; (c) $<$; (d) $<$;
 (e) $>$ 6. [1.2B] (a) 2800; (b) 9700; (c) 3600; (d) 4400;
 (e) 5600 7. [1.2C] (a) \$21,100; (b) \$27,300; (c) \$35,500;
 (d) \$26,500; (e) \$23,000 8. [1.3A] (a) 11,978; (b) 4481;
 (c) 9646; (d) 13,166; (e) 13,249 9. [1.3B] (a) 7 ft; (b) 11 ft;
 (c) 14 ft; (d) 12 ft; (e) 24 ft 10. [1.4A] (a) 29; (b) 17; (c) 29;
 (d) 9; (e) 49 11. [1.4A] (a) 187; (b) 89; (c) 89; (d) 178; (e) 186
 12. [1.4B] (a) \$4534; (b) \$4625; (c) \$4414; (d) \$4727; (e) \$4638
 13. [1.5A] (a) 1620; (b) 1372; (c) 1833; (d) 1344; (e) 4416
 14. [1.5A] (a) 26,568; (b) 95,403; (c) 225,630; (d) 194,733;
 (e) 500,151 15. [1.5B] (a) 77,220; (b) 120,120; (c) 178,200;
 (d) 55,800; (e) 437,080 16. [1.5C] (a) \$7920; (b) \$5280;
 (c) \$10,560; (d) \$6600; (e) \$13,200 17. [1.5D] (a) 360 in.^2 ;
 (b) 240 in.^2 ; (c) 360 in.^2 ; (d) 180 in.^2 ; (e) 288 in.^2
 18. [1.6A] (a–c) 0 19. [1.6A] (a–c) not defined 20. [1.6A]
 (a) 15; (b) 12; (c) 15; (d) 11; (e) 17 21. [1.6B] (a) 31;
 (b) 42; (c) 103; (d) 21; (e) 65 22. [1.6B] (a) 46 r 1; (b) 42 r 1;
 (c) 25 r 1; (d) 37 r 1; (e) 48 r 2 23. [1.6C] (a) \$1248; (b) \$936;
 (c) \$468; (d) \$432; (e) \$216 24. [1.7A] (a) prime; (b) composite;
 (c) prime; (d) composite; (e) prime 25. [1.7B] (a) 2, 5; (b) 5; (c) 3, 5;
 (d) 2; (e) 2, 17 26. [1.7C] (a) $2 \times 5 \times 5$ or 2×5^2 ; (b) 2×17 ;
 (c) $2 \times 2 \times 19$ or $2^2 \times 19$; (d) 3×13 ; (e) $3 \times 3 \times 3 \times 3$ or 3^4
 27. [1.7D] (a) 4; (b) 9; (c) 125; (d) 128; (e) 243 28. [1.7D] (a) 1125;
 (b) 27; (c) 225; (d) 200; (e) 80 29. [1.7D] (a) 12; (b) 50; (c) 675;
 (d) 25; (e) 1 30. [1.8A] (a) 54; (b) 45; (c) 36; (d) 27; (e) 19
 31. [1.8A] (a) 50; (b) 56; (c) 62; (d) 68; (e) 74 32. [1.8A] (a) 5; (b) 2;
 (c) 7; (d) 10; (e) 17 33. [1.8A] (a) 29; (b) 11; (c) 17; (d) 9; (e) 11
 34. [1.8B] (a) 25; (b) 35; (c) 45; (d) 57; (e) 64 35. [1.8C] (a) \$170;

(b) \$230; (c) \$140; (d) \$200; (e) \$260 36. [1.9A] (a) $x = 12$;
 (b) $x = 11$; (c) $x = 10$; (d) $x = 9$; (e) $x = 8$ 37. [1.9A] (a) $x = 7$;
 (b) $x = 6$; (c) $x = 5$; (d) $x = 4$; (e) $x = 3$ 38. [1.9A] (a) $x = 5$;
 (b) $x = 4$; (c) $x = 2$; (d) $x = 1$; (e) $x = 10$ 39. [1.9A] (a) $x = 7$;
 (b) $x = 6$; (c) $x = 5$; (d) $x = 4$; (e) $x = 3$ 40. [1.9B] (a) $n = 21$;
 (b) $n = 26$; (c) $n = 40$; (d) $n = 62$; (e) $n = 33$ 41. [1.9B]
 (a) $m = 32$; (b) $m = 58$; (c) $m = 25$; (d) $m = 57$; (e) $m = 65$
 42. [1.9B] (a) $m = 15$; (b) $m = 13$; (c) $m = 18$; (d) $m = 22$;
 (e) $m = 29$ 43. [1.9B] (a) $x = 12$; (b) $x = 13$; (c) $x = 12$;
 (d) $x = 9$; (e) $x = 12$ 44. [1.9B] (a) $x = 5$; (b) $x = 4$; (c) $x = 4$;
 (d) $x = 6$; (e) $x = 6$ 45. [1.9C] (a) 90 ft; (b) 100 ft; (c) 110 ft;
 (d) 85 ft; (e) 75 ft

Chapter 2

Exercises 2.1

1. $\frac{1}{2}$ 3. $\frac{1}{3}$ 5. $\frac{5}{12}$ 7. $\frac{1}{4}$ 9. $\frac{3}{4}$ 11. $\frac{2}{4}$ 13. $\frac{3}{4}$ 15. $\frac{4}{4}$ or 1 17. $\frac{2}{3}$
 19. 1 21. proper 23. proper 25. proper 27. proper 29. proper
 31. $3\frac{1}{10}$ 33. $1\frac{1}{7}$ 35. $3\frac{5}{8}$ 37. $7\frac{6}{9}$ 39. $10\frac{1}{10}$ 41. $\frac{36}{7}$ 43. $\frac{41}{10}$
 45. $\frac{13}{11}$ 47. $\frac{83}{10}$ 49. $\frac{13}{6}$ 51. $\frac{7}{24}$ 53. $\frac{7}{16}$ 55. $\frac{5}{8}$ 57. $\frac{51}{100}$
 59. (a) $\frac{60}{60} = 1$; (b) $\frac{90}{60} = \frac{3}{2} = 1\frac{1}{2}$; (c) $\frac{45}{60} = \frac{3}{4}$; (d) $\frac{15}{60} = \frac{1}{4}$ 61. $\frac{25}{98}$
 63. $\frac{6}{98}$ 65. $\frac{3}{98}$ 67. $\frac{37}{99}$ 69. $\frac{2}{99}$ 71. $\frac{7}{20}$ 73. $\frac{3}{20}$ 75. $\frac{1}{10}$
 77. Thermoelectric; $\frac{205}{408}$ 79. $\frac{43}{408}$ 81. 373; $\frac{27}{373}$ 83. $\frac{140}{373}$ 85. $\frac{157}{305}$
 87. 0, 1 89. $\frac{2}{4}$ 91. 18 93. 21 95. 350 mi
 97. No. You need $\frac{340}{20} = 17$ gallons and the tank holds 14.
 99. 12 gallons 105. denominator 107. greater 109. undefined
 111. $\frac{a}{b}$ 113. $\frac{5}{12}$ 115. $8\frac{1}{3}$ 117. improper 119. $2^2 \times 3^2$ 121. $2^2 \times 7$
 123. $2^2 \times 3^2 \times 5$

Exercises 2.2

1. 30 3. 30 5. 45 7. 15 9. 72 11. 4 13. 12 15. 3 17. $\frac{14}{15}$
 19. $\frac{1}{4}$ 21. $\frac{7}{3} = 2\frac{1}{3}$ 23. $\frac{3}{4}$ 25. $\frac{2}{3}$ 27. $\frac{3}{14}$ 29. $\frac{3}{13}$ 31. $\frac{23}{50}$ 33. $\frac{1}{6}$
 35. $\frac{20}{73}$ 37. (a) $\frac{1}{2}$; (b) $\frac{1}{4}$; (c) $\frac{1}{13}$ 39. the first recipe 41. $\frac{1}{4}$ 43. $\frac{1}{8}$
 45. $\frac{1}{8}$ 47. $\frac{7}{40}$ 49. $\frac{13}{35}$ 51. (a) $\frac{5}{258}$; (b) $\frac{1}{129}$ 53. (a) $\frac{9}{43}$; (b) $\frac{53}{258}$
 55. (a) $\frac{8}{129}$; (b) $\frac{3}{86}$ 57. \$115, \$180; $\frac{23}{36}$ 59. \$200, \$180; $\frac{10}{9}$
 61. $\frac{5}{6}$ 63. (a) $\frac{1}{28}$; (b) 400 69. equivalent 71. reduced
 73. $\frac{15}{25}$ 75. $\frac{3}{25}$ 77. $\frac{4}{23}$ 79. $\frac{27}{8}$ 81. $\frac{79}{10}$ 83. $\frac{132}{13}$

Exercises 2.3

1. $\frac{21}{32}$ 3. $\frac{1}{7}$ 5. $\frac{2}{3}$ 7. $\frac{6}{5} = 1\frac{1}{5}$ 9. $\frac{1}{2}$ 11. $\frac{3}{2} = 1\frac{1}{2}$ 13. 4 15. 2
 17. 7 19. $\frac{21}{2} = 10\frac{1}{2}$ 21. 13 23. 62 25. $\frac{25}{9}$ 27. $\frac{25}{4} = 6\frac{1}{4}$
 29. (a) $\frac{2}{15}$; (b) $\frac{1}{2}$ 31. $\frac{1}{3}$ 33. $\frac{2}{21}$ 35. $\frac{8}{27}$ 37. $\frac{15}{2} = 7\frac{1}{2}$ 39. $\frac{2}{15}$
 41. $\frac{7}{9}$ 43. $\frac{3}{2} = 1\frac{1}{2}$ 45. $\frac{8}{5} = 1\frac{3}{5}$ 47. 1 49. $\frac{2}{5}$ 51. 10
 53. $\frac{13}{5} = 2\frac{3}{5}$ 55. $\frac{75}{32} = 2\frac{11}{32}$ 57. 1 59. $\frac{4}{33}$ 61. $\frac{2}{7}$ square mile
 63. 72 people 65. 16 days 67. 8 turns 69. $\frac{84}{5} = 16\frac{4}{5}$ or 16 vests
 71. 660 73. 11 75. 13 77. $1\frac{1}{8}$ 79. $1\frac{1}{12}$ 81. 96 mi 83. 168 mi
 85. $\frac{20}{3} = 6\frac{2}{3}$ in. 87. $25\frac{5}{32}$ square inches 89. $39\frac{3}{16}$ square inches
 91. $43\frac{1}{8}$ square inches 93. $134\frac{2}{5}$ square inches 95. $4\frac{1}{2}$ yards
 97. $813\frac{3}{8}$ square inches 99. $657\frac{33}{64}$ square inches
 101. 26 ft 103. $1\frac{1}{8}$ cm 105. $3\frac{1}{8}$ inches 111. $\frac{a-c}{b-d}$ 113. $\frac{1}{2}$ cup
 115. $\frac{15}{4} = 3\frac{3}{4}$ 117. $\frac{27}{32}$ 119. 4 121. $\frac{140}{9} = 15\frac{5}{9}$ yd²
 123. 2⁷ 125. $2^2 \times 3^2 \times 5$ 127. $2^2 \times 3^2 \times 5^2$

Exercises 2.4

1. 40 3. 48 5. 18 7. 42 9. 60 11. $6\frac{2}{6} = \frac{1}{1}$ 13. $21\frac{1}{21} = \frac{3}{1}$
 15. 20; $\frac{15}{20} = \frac{3}{4}$ 17. 24; $\frac{4}{24} = \frac{1}{6}$ 19. 40; $\frac{24}{40} = \frac{3}{5}$ 21. $72\frac{4}{72} = \frac{3}{1}$

23. 160; $\frac{5}{160}$; $\frac{2}{160}$ 25. 20; $\frac{15}{20}$; $\frac{6}{20}$ 27. 24; $\frac{4}{24}$; $\frac{2}{24}$; $\frac{1}{24}$ 29. 40; $\frac{24}{40}$; $\frac{25}{40}$; $\frac{14}{40}$
 31. $\frac{7}{8}$ 33. $\frac{5}{11}$ 35. < 37. < 39. < 41. 60 min 43. 221 years
 45. 12 hours 47. 20 days 49. 12 days 51. It takes 60 years,
 so in 2060. 53. 420 years 57. They are the same. 59. LCM
 61. LCD 63. > 65. 45 67. $\frac{15}{35}$; $\frac{28}{35}$ 69. 180 71. $\frac{40}{72}$; $\frac{27}{72}$

Exercises 2.5

1. $\frac{2}{3}$ 3. $\frac{5}{7}$ 5. $\frac{2}{3}$ 7. 1 9. 2 11. $\frac{8}{15}$ 13. $\frac{2}{3}$ 15. $\frac{13}{10} = 1\frac{3}{10}$ 17. $\frac{11}{14}$
 19. $\frac{7}{8}$ 21. $\frac{29}{360}$ 23. $\frac{19}{130}$ 25. $\frac{23}{360}$ 27. $\frac{50}{60} = \frac{5}{6}$ 29. $\frac{316}{126} = \frac{158}{63} = 2\frac{32}{63}$
 31. $\frac{2}{7}$ 33. $\frac{2}{3}$ 35. $\frac{1}{6}$ 37. $\frac{1}{10}$ 39. $\frac{3}{40}$ 41. $\frac{11}{24}$ 43. $\frac{47}{240}$ 45. $\frac{5}{9}$ 47. 1
 49. $\frac{13}{6} = 2\frac{1}{6}$ 51. $\frac{37}{32} = 1\frac{5}{32}$ in. 53. $\frac{1}{8}$ 55. $\frac{9}{20}$ 57. $\frac{1}{6}$ 59. $\frac{3}{4}$ 61. $\frac{1}{5}$
 63. $\frac{1}{2}$ 65. $\frac{7}{10}$ 67. (a) $\frac{1}{2}$; (b) \$1500 69. (a) $\frac{9}{20}$; (b) \$1350
 71. Paper/Paperboard 73. $\frac{3}{20}$ 75. Paper/Paperboard and Food Scraps
 or Paper/Paperboard and Plastics 77. $\frac{33}{200}$
 79. 4 packages of hot dogs, 5 packages of buns 85. $\frac{a+b}{c}$
 87. 90 89. $\frac{7}{24}$ 91. $\frac{67}{120}$ 93. $\frac{31}{120}$ 95. $\frac{16}{5}$ 97. $\frac{55}{8}$ 99. $1\frac{2}{3}$

Exercises 2.6

1. $4\frac{4}{7}$ 3. $2\frac{4}{7}$ 5. $5\frac{1}{2}$ 7. $4\frac{2}{5}$ 9. $5\frac{1}{7}$ 11. $2\frac{53}{60}$ 13. $4\frac{13}{60}$ 15. $4\frac{7}{12}$
 17. $11\frac{16}{63}$ 19. $12\frac{21}{110}$ 21. $2\frac{2}{7}$ 23. $1\frac{2}{3}$ 25. $1\frac{5}{6}$ 27. $\frac{7}{10}$ 29. $\frac{39}{40}$
 31. $2\frac{11}{24}$ 33. $\frac{47}{240}$ 35. 4 37. $3\frac{2}{3}$ 39. $5\frac{5}{12}$ 41. $12\frac{3}{130}$ 43. $18\frac{11}{60}$
 45. 3 47. $1\frac{5}{16}$ lb 49. $3\frac{3}{4}$ cups 51. $5\frac{3}{4}$ lb 53. $\frac{3}{10}$ 55. $\frac{7}{10}$ hr
 57. $3\frac{3}{10}$ billion metric tons 59. 52 ft 61. $3\frac{3}{8} + \frac{1}{4}$; $3\frac{5}{8}$ 63. $2\frac{2}{3} - 1\frac{5}{8}$;
 $1\frac{1}{24}$ 65. $69\frac{5}{6}$ ft 67. $69\frac{5}{6}$ ft 69. No 73. LCD 75. $2\frac{49}{60}$ 77. $6\frac{7}{12}$
 79. $2\frac{31}{180}$ 81. $\frac{1}{4}$ 83. $\frac{128}{75}$ or $1\frac{53}{75}$

Exercises 2.7

1. $\frac{13}{60}$ 3. $\frac{19}{84}$ 5. 0 7. $\frac{13}{30}$ 9. $\frac{7}{6} = 1\frac{1}{6}$ 11. $\frac{1}{2}$ 13. $\frac{7}{36}$
 15. $\frac{52}{15} = 3\frac{7}{15}$ 17. $\frac{63}{80}$ 19. $\frac{17}{20}$ 21. $\frac{6}{5} = 1\frac{1}{5}$ 23. $\frac{35}{8} = 4\frac{3}{8}$
 25. 0 27. $31\frac{3}{5}$ MPG 29. $31\frac{11}{30}$ lb 31. (a) \$200 $\frac{1}{2}$ million;
 (b) \$401 $\frac{11}{15}$ million 33. $8\frac{8}{15}$ nights 35. $14\frac{1}{6}$ hr per wk
 37. $20\frac{11}{30}$ hr per wk 39. Women 18 and over 41. $5\frac{1}{6}$ lb 43. $23\frac{7}{16}$ lb
 45. (a) 8, 4, 2, 1; (b) $A_8 = \frac{15}{4} = 3\frac{3}{4}$; (c) $H_8 = \frac{32}{15} = 2\frac{2}{15}$; (d) Yes
 49. parentheses 51. multiplication 53. addition 55. $\frac{83}{20} = 4\frac{3}{20}$
 57. $\frac{25}{36}$ 59. $\frac{83}{162}$ 61. $3\frac{7}{8}$ 63. $x = 6$ 65. $x = 3$

Exercises 2.8

Translate This

1. I 3. B 5. C 7. D 9. M

1. = 3. \times 5. + 7. - 9. $2 \cdot n$ 11. $5 + n$ 13. $n - 7$
 15. $\frac{3}{4} \div n = 5$ 17. $\frac{1}{2} \cdot 3 \cdot n = 2$ 19. $\frac{n}{2} - 4 = \frac{3}{2}$ 21. $m + \frac{1}{8} = \frac{3}{7}$;
 $m = \frac{17}{56}$ 23. $p + \frac{2}{5} = 1\frac{3}{4}$; $p = \frac{27}{20} = 1\frac{7}{20}$ 25. $y - \frac{3}{4} = \frac{4}{5}$; $y = \frac{31}{20} = 1\frac{11}{20}$
 27. $\frac{n}{6} = 3\frac{1}{2}$; $n = 21$ 29. $3 \cdot t = 2\frac{2}{3}$; $t = \frac{11}{15}$ 31. $1\frac{1}{2} \cdot n = 7\frac{1}{2}$; $n = 5$
 33. $n \cdot 1\frac{2}{3} = 4$; $n = \frac{12}{5} = 2\frac{2}{5}$ 35. $n \cdot 2\frac{1}{2} = 6\frac{1}{4}$; $n = \frac{5}{2} = 2\frac{1}{2}$
 37. $1\frac{1}{3} \cdot n = 4\frac{2}{3}$; $n = \frac{7}{2} = 3\frac{1}{2}$ 39. $1\frac{1}{8} \cdot 2\frac{1}{2} = n$; $n = \frac{45}{16} = 2\frac{13}{16}$
 41. 30 in. 43. 1 cup 45. 24 lb 47. $\frac{5}{2} = 2\frac{1}{2}$ km 49. 70¢
 51. $\frac{13}{25}$ 53. 77 55. 69°F 57. (a) $\frac{1}{6}$; (b) $\frac{1}{3}$; (c) $\frac{1}{2}$; (d) 25 59. (a) $7\frac{1}{12}$;
 (b) $56\frac{2}{3}$; (c) $5\frac{2}{3}$ 61. 990 63. 22 65. $4\frac{1}{2}$ oz 67. $3\frac{1}{2}$ oz 69. 5 oz
 75. $a - c = b - c$ 77. $a \div c = b \div c$ 79. $2\frac{1}{2}$ 81. (a) $3n = 9$;
 (b) $n - 5 = 2$; (c) $n + 8 = 7$ 83. $9\frac{2}{7}$ 85. 3 mi 87. 190 89. 6

Review Exercises

1. [2.1B] (a) Proper; (b) Proper; (c) Improper; (d) Proper;
 (e) Improper 2. [2.1C] (a) $3\frac{1}{7}$; (b) $2\frac{4}{7}$; (c) $9\frac{2}{3}$; (d) $3\frac{1}{2}$; (e) $1\frac{8}{11}$ 3. [2.1D]
 (a) $\frac{9}{2}$; (b) $\frac{28}{9}$; (c) $\frac{22}{5}$; (d) $\frac{115}{14}$; (e) $\frac{63}{8}$ 4. [2.1E] (a) 8; (b) 10; (c) 4; (d) 2;
 (e) 5 5. [2.2A] (a) 8; (b) 15; (c) 24; (d) 28; (e) 18 6. [2.2A] (a) 7;

- (b) 5; (c) 8; (d) 8; (e) 10 7. [2.2B] (a) $\frac{1}{2}$; (b) $\frac{2}{3}$; (c) $\frac{2}{5}$; (d) $\frac{2}{7}$; (e) $\frac{2}{19}$
 8. [2.2B] (a) 12, $\frac{1}{3}$; (b) 10, $\frac{1}{5}$; (c) 9, $\frac{2}{5}$; (d) 14, $\frac{2}{3}$; (e) 17, $\frac{3}{2}$ 9. [2.3A]
 (a) $\frac{2}{21}$; (b) $\frac{2}{9}$; (c) $\frac{1}{3}$; (d) $\frac{3}{2} = 1\frac{1}{2}$; (e) 1 10. [2.3B] (a) $\frac{38}{21} = 1\frac{17}{21}$;
 (b) 2; (c) $\frac{3}{2} = 1\frac{1}{2}$; (d) $\frac{81}{40} = 2\frac{1}{40}$; (e) 4 11. [2.3C] (a) $\frac{2}{15}$; (b) 1; (c) $\frac{2}{3}$;
 (d) $\frac{7}{6} = 1\frac{1}{6}$; (e) 2 12. [2.3D] (a) $\frac{7}{8}$; (b) $\frac{7}{16}$; (c) $\frac{36}{25} = 1\frac{11}{25}$; (d) $\frac{15}{7} = 2\frac{1}{7}$;
 (e) $\frac{1}{2}$ 13. [2.3E] (a) $\frac{45}{16} = 2\frac{13}{16}$; (b) $\frac{176}{49} = 3\frac{29}{49}$; (c) $\frac{169}{8} = 21\frac{1}{8}$; (d) $\frac{3}{2} = 1\frac{1}{2}$;
 (e) $\frac{435}{98} = 4\frac{43}{98}$ 14. [2.3E] (a) $\frac{1}{2}$; (b) $\frac{4}{7}$; (c) $\frac{3}{16}$; (d) $\frac{2}{35}$; (e) $\frac{16}{225}$
 15. [2.3G] (a) $15\frac{5}{9}$ square yards; (b) $15\frac{5}{9}$ square yards; (c) 15 square
 yards; (d) $15\frac{5}{9}$ square yards; (e) $24\frac{3}{4}$ square yards 16. [2.4A]
 (a) 24; (b) 30; (c) 36; (d) 120; (e) 540 17. [2.4A] (a) 33; (b) 34;
 (c) 57; (d) 40; (e) 92 18. [2.4B] (a) 48, $\frac{28}{48}$; (b) 45, $\frac{6}{45}$; (c) 144,
 $\frac{45}{144}$; (d) 35, $\frac{15}{35}$; (e) 45, $\frac{25}{45}$ 19. [2.4B] (a) 12, $\frac{9}{12}$; (b) $\frac{6}{12}$, $\frac{10}{12}$;
 (b) 72, $\frac{30}{72}$; (c) 144, $\frac{117}{144}$; (d) 120, $\frac{120}{120}$; (e) 360, $\frac{72}{360}$; (e) $\frac{160}{360}$ 20. [2.4C] (a) >; (b) >; (c) >; (d) <; (e) >
 21. [2.5A] (a) $\frac{4}{5}$; (b) 1; (c) $\frac{4}{7}$; (d) $\frac{1}{3}$; (e) 8 22. [2.5B] (a) $6\frac{7}{6} = 1\frac{1}{6}$;
 (b) 45; (c) 42; (d) $\frac{53}{42} = 1\frac{11}{42}$; (e) 60; (f) 105; (g) $\frac{51}{105} = \frac{17}{35}$ 23. [2.5B]
 (a) 12; (b) $\frac{109}{12} = 9\frac{1}{12}$; (c) 6; (d) $\frac{31}{6} = 5\frac{1}{6}$; (e) 16; (f) $\frac{101}{16} = 6\frac{5}{16}$; (g) $\frac{58}{9} = 6\frac{4}{9}$;
 (h) 72; (i) $\frac{233}{72} = 3\frac{17}{72}$ 24. [2.5D] (a) $\frac{67}{84}$; (b) $\frac{5}{24}$; (c) $\frac{21}{16} = 1\frac{5}{16}$; (d) 1;
 (e) $\frac{4}{3} = 1\frac{1}{3}$ 25. [2.5D] (a) $\frac{1}{8}$; (b) $\frac{19}{36}$; (c) $\frac{13}{48}$; (d) $\frac{4}{35}$; (e) $\frac{83}{216}$ 26. [2.5E]
 (a) $\frac{3}{4}$; (b) $\frac{19}{50}$; (c) $\frac{23}{100}$; (d) $\frac{13}{25}$; (e) $\frac{3}{25}$ 27. [2.6B] (a) $7\frac{11}{30}$; (b) $5\frac{5}{12}$; (c) $7\frac{23}{28}$;
 (d) $7\frac{7}{8}$; (e) $8\frac{7}{8}$ 28a. [2.6C] (a) $\frac{26}{15} = 1\frac{11}{15}$; (b) $\frac{17}{15} = 1\frac{2}{15}$; (d) $\frac{37}{40}$;
 (e) $\frac{23}{72}$ 28b. [2.6D] (a) $3\frac{209}{360}$; (b) $4\frac{28}{45}$; (c) $3\frac{37}{72}$; (d) $6\frac{17}{36}$; (e) $7\frac{37}{72}$
 29. [2.6E] (a) $19\frac{1}{2}$ yards; (b) $15\frac{2}{3}$ yards; (c) $19\frac{2}{3}$ yards; (d) $17\frac{2}{3}$ yards;
 (e) 12 yards 30. [2.7A] (a) $\frac{1}{9}$; (b) $\frac{1}{8}$; (c) $\frac{1}{9}$; (d) $\frac{5}{49}$; (e) $\frac{3}{32}$ 31. [2.7A]
 (a–e) $\frac{1}{3}$ 32. [2.7A] (a) $\frac{89}{96}$; (b) $\frac{121}{96} = 1\frac{25}{96}$; (c) $\frac{19}{32}$; (d) $\frac{2}{3}$; (e) $\frac{7}{4} = 1\frac{3}{4}$
 33. [2.7B] (a) $\frac{17}{21}$; (b) $\frac{5}{6}$; (c) $\frac{13}{15}$; (d) $\frac{11}{12}$; (e) 1 34. [2.7C] (a) $4\frac{3}{8}$ lb;
 (b) $5\frac{3}{8}$ lb; (c) $6\frac{3}{8}$ lb; (d) $7\frac{3}{8}$ lb; (e) $8\frac{3}{8}$ lb 35. [2.8A] (a) $n + 8 = 10$;
 (b) $n - 5 = 1$; (c) $2n = 12$; (d) $\frac{n}{2} = 8$; (e) $\frac{n}{7} = 3$ 36. [2.8B]
 (a) $p + \frac{1}{6} = \frac{1}{3}$; $p = \frac{1}{6}$; (b) $q + \frac{1}{5} = \frac{1}{4}$; $q = \frac{1}{20}$; (c) $r + \frac{1}{4} = \frac{2}{5}$; $r = \frac{3}{20}$;
 (d) $s + \frac{1}{3} = \frac{5}{6}$; $s = \frac{1}{2}$; (e) $t + \frac{1}{2} = \frac{6}{7}$; $t = \frac{5}{14}$ 37. [2.8B]
 (a) $r - \frac{1}{6} = \frac{2}{7}$; $r = \frac{19}{42}$; (b) $s - \frac{1}{5} = \frac{3}{7}$; $s = \frac{22}{35}$; (c) $t - \frac{1}{4} = \frac{4}{7}$; $t = \frac{23}{28}$;
 (d) $u - \frac{1}{3} = \frac{5}{7}$; $u = \frac{22}{21} = 1\frac{1}{21}$; (e) $v - \frac{1}{2} = \frac{6}{7}$; $v = \frac{19}{14} = 1\frac{5}{14}$
 38. [2.8B] (a) $\frac{v}{3} = \frac{2}{7}$; $v = \frac{6}{7}$; (b) $\frac{v}{4} = \frac{3}{7}$; $v = \frac{12}{7} = 1\frac{5}{7}$;
 (c) $\frac{v}{5} = \frac{4}{7}$; $v = \frac{20}{7} = 2\frac{6}{7}$; (d) $\frac{v}{6} = \frac{5}{7}$; $v = \frac{30}{7}$; (e) $\frac{v}{7} = \frac{6}{7}$; $v = 6$ 39. [2.8B]
 (a) 16; (b) 6; (c) 45; (d) 49; (e) 10 40. [2.8C] (a) $\frac{77}{100}$; (b) $\frac{61}{100}$; (c) $\frac{53}{100}$;
 (d) $\frac{9}{20}$; (e) $\frac{33}{100}$

Cumulative Review Chapters 1–2

1. 400 + 30 + 8 2. 984 3. seventy-four thousand, eight 4. 6710
 5. 8600 6. 3679 7. 154 8. 43,703 9. \$3720 10. 34 r 5
 11. 2, 3 12. $2^2 \times 3^2 \times 5$ 13. 32 14. 40 15. 23 16. 3
 17. proper 18. $5\frac{1}{2}$ 19. $\frac{9}{4}$ 20. 14 21. 27 22. $\frac{5}{6}$ 23. <
 24. $\frac{19}{6} = 3\frac{1}{6}$ 25. $\frac{1}{36}$ 26. $\frac{9}{14}$ 27. 30; $6\frac{19}{30}$ 28. $6\frac{16}{63}$ 29. $z - \frac{6}{7} = \frac{4}{9}$;
 $z = \frac{82}{63}$ 30. $5\frac{7}{9}$ 31. \$1.12 32. 22 yd 33. $28\frac{8}{9}$ yd² 34. 80
 35. 76 36. $36\frac{28}{36}$ 37. $30\frac{21}{30}$; $\frac{25}{30}$

Chapter 3

Exercises 3.1

1. Three and eight tenths 3. Thirteen and twelve hundredths
 5. One hundred thirty-two and thirty-four hundredths
 7. Five and one hundred eighty-three thousandths
 9. Two thousand, one hundred seventy-two ten-thousandths
 11. $3 + \frac{2}{10} + \frac{1}{100}$ 13. $40 + 1 + \frac{3}{10} + \frac{8}{100}$
 15. $80 + 9 + \frac{1}{10} + \frac{2}{100} + \frac{3}{1000}$
 17. $200 + 30 + 8 + \frac{3}{10} + \frac{9}{100} + \frac{2}{1000}$

19. $300 + 1 + \frac{5}{10} + \frac{8}{100} + \frac{7}{1000} + \frac{9}{10,000}$ 21. 0.5 23. 1.5 25. 0.2
 27. 3.1 29. 1.8 31. 4.9 33. 1.9 35. 0.3 37. 21.23 39. 23.33
 41. 8.95 43. \$989.07 45. 919.154 47. 182.103 49. 4.077
 51. 26.85 53. 2.38 55. 3.024 57. 6.844 59. 9.0946
 61. 392.5 mi 63. \$54.58 65. 23.61 67. 93.5 69. 103.4%
 71. \$230.50; \$82,980 73. \$86.67; \$31,201.20 75. \$30.99;
 \$11,156.40 77. 62.26 79. 64.17 81. \$87.50 83. \$718.70
 85. 3.7 mi 87. 1.1 mi 89. 2.3 mi 91. 0.2 mi 93. "And"
 indicates a decimal point, but this is a whole number 95. 1, 8
 on both cases 97. whole, decimal, decimal 99. decimal
 101. 42.463 103. $40 + 1 + \frac{2}{10} + \frac{0}{100} + \frac{8}{1000}$ 105. 454.83
 107. 1.6 mi 109. 230 111. 240,000 113. 3500

Exercises 3.2

1. 0.35 3. 0.64 5. 0.00035 7. 5.6396 9. 95.7 11. 0.024605
 13. 12.90516 15. 0.002542 17. 423.3 19. 1950 21. 32,890
 23. 4.8 25. 3.9 27. 0.6 29. 6.4 31. 1700 33. 80 35. 0.046
 37. 30 39. 100 41. 3.2 43. 10 45. 338.12 47. 0.078
 49. 0.0005 51. 0.33 53. 0.09 55. 0.23 57. 0.01 59. 0.03
 61. \$35.24 63. (a) \$16.08; (b) \$482.40 65. \$54.00
 67. \$58.26 69. \$380.49 71. 0.915 sec 73. 0.305 sec
 75. 5.55 min 77. 240 gallons; 6000 lb/year; \$552
 79. 400 gallons; 10,000 lb/year; \$920 81. 600 gallons; 15,000 lb/
 year; \$1380 83. 1200 gallons; 30,000 lb/year; \$2760
 85. \$287.50; 3125 lb 87. 5.1 89. 2.3 91. 3.4 93. 19¢; \$1900
 95. 69.5 in. 97. 59.5 in. 99. 67.4 in. 101. 73.8 in.
 103. 88.2 in.; table does not apply 109. right, zeros
 111. left, divisor 113. 642.86 115. 0.0005 117. (a) 324.23;
 (b) 48,400; (c) 32.8 119. (a) 14.112; (b) 75.0924
 121. 4 123. 16

Exercises 3.3

1. 0.5 3. 0.6875 5. 0.45 7. 0.9 9. 0.25 11. 0.83 13. 0.43
 15. 2.67 17. 0.33 19. 0.18 21. $\frac{4}{5}$ 23. $\frac{19}{100}$ 25. $\frac{3}{100}$ 27. $\frac{31}{10}$
 29. $\frac{5}{9}$ 31. $\frac{7}{33}$ 33. $\frac{1}{9}$ 35. 0.375 37. 25 39. 4.8 41. 35
 43. 0.333 45. 0.7 47. \$2.18 49. 0.625 51. 0.056 53. 0.48
 55. $\frac{6}{25} = 0.24$ 57. $\frac{1}{5} = 0.20$ 59. $\frac{1}{5} = 0.20$ 61. 0.35 63. 0.15
 65. 0.06 67. 0.07 69. 0.10 71. 0.0625; 0.0625
 73. 0.09375; 0.0938 77. numerator, denominator 79. numerator
 81. 0.6 83. (a) $\frac{41}{100}$; (b) $\frac{303}{1000}$ 85. (a) $\frac{7}{200}$; (b) $\frac{3}{80}$
 87. (a) 0.6; (b) 0.225 89. < 91. <

Exercises 3.4

1. 66.606 > 66.066 > 66.06 3. 0.5101 > 0.51 > 0.501
 5. 9.999 > 9.909 > 9.099 7. 7.430 > 7.403 > 7.043
 9. $3.1\bar{4} > 3.14 > 3.14$ 11. $5.1\bar{2} > 5.1 > 5.1$
 13. $0.\bar{3} > 0.333 > 0.33$ 15. $0.\bar{8} > 0.88 > 0.81$ 17. $\frac{1}{9}$ 19. $\frac{1}{6}$
 21. $\frac{2}{7}$ 23. 0.14 25. 0.9 27. (a) $\frac{7}{100} = 0.07$, $\frac{12}{25} = 0.48$; $\frac{31}{100} = 0.31$,
 $\frac{7}{50} = 0.14$; (b) Most: space heating; Least: cooling 29. 30
 31. 12.48 33. 12.09 35. $9.1\bar{6}$ 37. 3 39. 0.495 41. 0.33
 43. 148.3 45. 28.68 47. $1\frac{1}{6}$ or $\frac{7}{6}$ 49. $\frac{1}{2}$ 51. $\frac{7}{36}$
 53. Copper > Nickel > Cadmium > Brass 55. $\frac{22}{7}$ is greater.
 57. decimal 59. exponential 61. 33 63. A
 65. 8.015 > 8.01 > 8.005 67. 28.395 69. 50 71. 18.8

Exercises 3.5

Translate This

1. E 3. F 5. H 7. A 9. K
 1. $x = 1.5$ 3. $y = 6.5$ 5. $z = 5.6$ 7. $z = 16.5$ 9. $m = 6$
 11. $m = 0.7$ 13. $n = 23.8$ 15. $n = 12.4$ 17. $T = 7.5$ tons;
 15,000 miles driven 19. 20,000 21. 4.62 23. \$0.5 billion
 25. \$36.03 billion 27. \$300 29. 1023 31. About 32
 33. 1.9 35. 8200 37. 172 39. \$10,000 41. (a) $T + S = 1062$;
 (b) $T = S + 140$; (c) $T = \$461 + \$140 = \$601$ million

43. (a) $T + B = 92$; (b) $T = B + 10$; (c) $B = 41$ 45. 55 mph
 47. 3.2 51. $a + c = b + c$ 53. $a \cdot c = b \cdot c$ 55. 18.4
 57. 10.1 59. \$507.16 61. $\frac{19}{35}$ 63. $1\frac{22}{35}$

Review Exercises

1. [3.1A] (a) Twenty-three and three hundred eighty-nine thousandths;
 (b) Twenty-two and thirty-four hundredths;
 (c) Twenty-four and five hundred sixty-four thousandths;
 (d) Twenty-seven and eight tenths;
 (e) Twenty-nine and sixty-seven hundredths
 2. [3.1B] (a) $30 + 7 + \frac{4}{10}$; (b) $50 + 9 + \frac{9}{100}$;
 (c) $100 + 40 + 5 + \frac{3}{100} + \frac{5}{1000}$; (d) $100 + 50 + \frac{3}{10} + \frac{9}{1000}$;
 (e) $200 + 30 + 4 + \frac{3}{1000}$ 3. [3.1C] (a) 21.94; (b) 25.4257;
 (c) 23.7756; (d) 29.452; (e) 23.52 4. [3.1C] (a) 39.36; (b) 48.034;
 (c) 27.662; (d) 41.12; (e) 47.7617 5. [3.1D] (a) 314.801; (b) 323.44;
 (c) 278.275; (d) 347.55; (e) 23.66 6. [3.2A] (a) 0.03768; (b) 0.3276;
 (c) 3.317175; (d) 0.03752; (e) 1.026 7. [3.2B] (a) 370; (b) 4.9;
 (c) 2.5; (d) 4285; (e) 945 8. [3.2C] (a) 61; (b) 63; (c) 92; (d) 8.07;
 (e) 90.8 9. [3.2D] (a) 329.7; (b) 238.3; (c) 887.4; (d) 459.4;
 (e) 348.3 10. [3.2D] (a) 5.33; (b) 5.63; (c) 6.86; (d) 6.46; (e) 6.93
 11. [3.2E] (a) 0.0312; (b) 0.00418; (c) 0.321; (d) 8.215; (e) 4.723
 12. [3.2F] (a) \$0.32 or 32¢; (b) \$0.34 or 34¢; (c) \$0.30 or 30¢;
 (d) \$0.28 or 28¢; (e) \$0.27 or 27¢ 13. [3.3A] (a) 0.6; (b) 0.9;
 (c) 2.5; (d) 0.1875; (e) 0.875 14. [3.3A] (a) $0.\bar{3}$; (b) $0.8\bar{3}$;
 (c) $0.\bar{6}$; (d) 0.285714; (e) $0.\bar{1}$ 15. [3.3B] (a) $\frac{19}{50}$; (b) $\frac{41}{100}$; (c) $\frac{3}{5}$;
 (d) $\frac{3}{100}$; (e) $\frac{333}{1000}$ 16. [3.3B] (a) $\frac{233}{100}$; (b) $\frac{347}{100}$; (c) $\frac{131}{20}$; (d) $\frac{137}{100}$;
 (e) $\frac{1067}{500}$ 17. [3.3C] (a) $\frac{5}{11}$; (b) $\frac{8}{99}$; (c) $\frac{80}{999}$; (d) $\frac{4}{999}$; (e) $\frac{11}{999}$
 18. [3.3D] (a) 0.25; (b) 0.6; (c) 0.5; (d) 0.75; (e) 0.1875
 19. [3.3D] (a) 0.2; (b) 0.25; (c) $0.14285\bar{7}$; (d) 0.3; (e) $0.1\bar{6}$
 20. [3.4A] (a) $1.032 > 1.03 > 1.003$; (b) $2.032 > 2.03 > 2.003$;
 (c) $3.033 > 3.032 > 3.03$; (d) $4.055 > 4.052 > 4.05$; (e) $5.033 > 5.03$
 > 5.003 21. [3.4A] (a) $1.21\bar{6} > 1.21\bar{6} > 1.216$; (b) $2.33\bar{6} > 2.33\bar{6}$
 > 2.336; (c) $3.21\bar{6} > 3.21\bar{6} > 3.216$; (d) $4.54\bar{2} > 4.54\bar{2} > 4.542$;
 (e) $5.12\bar{3} > 5.12\bar{3} > 5.123$ 22. [3.4B] (a) >; (b) >; (c) <; (d) <;
 (e) > 23. [3.4C] (a) 29; (b) 25; (c) 33; (d) 39; (e) 23
 24. [3.5A] (a) $x = 4.3$; (b) $x = 2.3$; (c) $x = 0.5$; (d) $x = 3.6$;
 (e) $x = 2.7$ 25. [3.5A] (a) $y = 7.3$; (b) $y = 7.7$; (c) $y = 13.32$;
 (d) $y = 10$; (e) $y = 11.5$ 26. [3.5A] (a) $y = 5$; (b) $y = 7$;
 (c) $y = 4$; (d) $y = 8$; (e) $y = 8$ 27. [3.5A] (a) $z = 24.6$;
 (b) $z = 35.7$; (c) $z = 10.8$; (d) $z = 44.02$; (e) $z = 56.7$
 28. [3.5B] (a) \$44.23; (b) \$42.96; (c) \$47.68; (d) \$46.78; (e) \$49.50

Cumulative Review Chapters 1–3

1. 394 2. 3210 3. 2, 5 4. $2^2 \times 3 \times 5$ 5. 20 6. 52
 7. improper 8. $5\frac{1}{2}$ 9. $\frac{43}{8}$ 10. 18 11. 35 12. $\frac{31}{12} = 2\frac{7}{12}$ 13. $\frac{1}{4}$
 14. $\frac{81}{20} = 4\frac{1}{20}$ 15. $15\frac{1}{24}$ 16. $11\frac{7}{12}$ 17. $z - \frac{6}{7} = \frac{3}{5}$; $z = \frac{51}{35} = 1\frac{16}{35}$
 18. 4 19. \$0.98 or 98¢ 20. One hundred thirty-five and sixty-four
 hundredths 21. $90 + 4 + \frac{4}{10} + \frac{7}{100} + \frac{8}{1000}$ 22. 56.344
 23. 228.92 24. 11.362 25. 1700 26. 250 27. 76.92
 28. \$0.38 or 38¢ 29. $0.8\bar{3}$ 30. $\frac{7}{20}$ 31. $\frac{26}{33}$ 32. 0.2 33. $\frac{1}{10}$
 34. $5.31\bar{4} > 5.31\bar{4} > 5.314$ 35. < 36. $x = 7.3$ 37. $y = 8$
 38. $z = 33.6$

Chapter 4

Exercises 4.1

1. $\frac{3}{8}$ 3. $\frac{1}{7}$ 5. $\frac{8}{1}$ 7. $\frac{11}{3}$ 9. $\frac{10}{3}$ 11. $\frac{21}{4} = 5.25$; You are a popular
 person and people want to hear what you have to say. 13. $\frac{15}{68} = 0.22$;
 You are seeking knowledge and friends. 15. $\frac{0}{4} = 0$; You are seeking
 knowledge and friends. 17. $\frac{103}{100} = 1.03$ 19. $\frac{63}{100} = 0.63$
 21. $\frac{85.9}{100} = \frac{859}{1000} = 0.86$ 23. 3.60; Protective 25. 4.75; Warning
 27. 4.67; Warning 29. 1.96; Protective 31. (a) $\frac{959}{485}$; (b) 1.977
 33. $\frac{48}{100} = \frac{12}{25} = 0.48 = 48\%$ 35. $\frac{15}{8}$ 37. $\frac{4}{25}$ 39. No. The ratio is $\frac{1}{0}$,
 which is undefined. (Division by 0 is undefined.) 41. quotient
 43. $\frac{17}{21}$ 45. $\frac{7}{20}$ 47. $\frac{3}{2}$ 49. 277.78

Exercises 4.2

1. \$4.75 3. 21.5 5. 560 mi/hr 7. 1229.5 mi/hr 9. 2.5 tortillas/min
 11. 2.63 13. 12 15. 1.5 in./hr 17. 740 calories/lb
 19. 30.1 points/game 21. \$10.38 23. \$21.75 25. \$25.57
 27. 200 29. 75 31. 38¢/oz; 40¢/oz; First 33. 8¢/oz; 9¢/oz; First
 35. \$1.80/oz; \$2.53/oz; First 37. (a) 6¢; (b) 5¢; (c) White Magic
 39. (a) $\frac{4}{5}$; (b) $\frac{80}{100}$; (c) 80% 41. (a) 360; (b) 300; (c) 600 43. 1.5
 45. (a) \$34.80; (b) \$3.48 51. rate 53. 38.3¢/oz 55. (a) \$254.20;
 (b) \$6.20 57. 22 59. $x = 6$ 61. $x = \frac{15}{7}$ 63. $x = 15$

Exercises 4.3

1. $\frac{1}{4} = \frac{5}{20}$ 3. $\frac{a}{3} = \frac{b}{7}$ 5. $\frac{a}{6} = \frac{b}{18}$ 7. $\frac{3}{a} = \frac{12}{b}$ 9. no 11. yes 13. yes
 15. yes 17. no 19. $x = 8$ 21. $x = 20$ 23. $x = 48$ 25. $x = 15$
 27. $x = 25$ 29. $x = 14$ 31. $x = 12$ 33. $x = 9$ 35. $x = \frac{128}{9}$
 37. $x = 11$ 39. $x = 6.125$ 41. $\frac{2}{26} = \frac{8}{d}$; $d = 104$ 43. $\frac{5}{4} = \frac{8}{x}$; $x = 6.40$
 45. $\frac{4.38}{4} = \frac{y}{6}$; $y = 6.57$ 47. $\frac{9}{3} = \frac{z}{5}$; $z = 15$ 49. $\frac{6.95}{4} = \frac{5.56}{x}$; $x = 4$
 51. $\frac{17}{50}$ 53. $\frac{57}{5000}$ 55. (a) 1000; (b) 19,000; (d) 396 57. (a) 600;
 (b) 11,400; (d) 238 59. \$360 61. 5760 cm or 57.60 m
 63. 120,000 65. (a) $\frac{17}{20}$; (b) 425; (c) 680 67. 4000 69. 21,250
 71. (a) $\frac{4}{3}$; (b) 24 in. 73. 365 75. 208 81. proportion
 83. (a) $\frac{2}{5} = \frac{4}{10}$; (b) $\frac{5}{8} = \frac{15}{24}$ 85. yes 87. 9 hours 89. $p = 25$ 91. $c = 1$

Exercises 4.4

1. 15 lb 3. 760 5. 8 7. 250 9. 40 min 11. 7700 13. 24
 15. 20 17. \$5.75 billion 19. 86,250 21. 39 23. 28
 25. 1750 million 27. 360 29. 70 mi 31. 200 33. 169
 35. 24,500 37. No 39. translate 41. 2 teaspoons/day 43. 200
 45. 400 47. 245.9 49. 250

Review Exercises

1. [4.1A] (a) $\frac{1}{10}$; (b) $\frac{1}{5}$; (c) $\frac{3}{10}$; (d) $\frac{2}{5}$; (e) $\frac{1}{2}$ 2. [4.1A] (a) $\frac{17}{40}$; (b) $\frac{13}{40}$;
 (c) $\frac{3}{10}$; (d) $\frac{3}{20}$; (e) $\frac{1}{25}$ 3. [4.1A] (a) $\frac{22}{7}$; (b) $\frac{729}{232}$; (c) $\frac{292}{93}$; (d) $\frac{732}{233}$; (e) $\frac{1468}{467}$
 4. [4.1A] (a) $\frac{29}{21}$; (b) $\frac{11}{9}$; (c) $\frac{13}{12}$; (d) $\frac{12}{13}$; (e) $\frac{23}{27}$ 5. [4.2A] (a) \$6; (b) \$4;
 (c) \$3; (d) \$2; (e) \$1.50 6. [4.2A] (a) 22; (b) 21; (c) 20; (d) 19;
 (e) 18 7. [4.2A] (a) 250; (b) 227; (c) 208; (d) 200; (e) 100
 8. [4.2B] (a) 10¢; (b) 15¢; (c) 7¢; (d) 6¢; (e) 5¢ 9. [4.2B] (a) Brand X;
 (b) Brand X; (c) Brand X; (d) Brand X; (e) generic 10. [4.3A]
 (a) $\frac{3}{7} = \frac{6}{x}$; (b) $\frac{4}{7} = \frac{12}{x}$; (c) $\frac{5}{7} = \frac{x}{21}$; (d) $\frac{6}{7} = \frac{33}{x}$; (e) $\frac{7}{35} = \frac{5}{x}$ 11. [4.3B]
 (a) no; (b) yes; (c) no; (d) yes; (e) yes 12. [4.3C] (a) $x = 2$; (b) $x = 3$;
 (c) $x = 4$; (d) $x = 5$; (e) $x = 6$ 13. [4.3C] (a) $x = 5$; (b) $x = 10$;
 (c) $x = 15$; (d) $x = 25$; (e) $x = 30$ 14. [4.3C] (a) $x = 18$; (b) $x = 3$;
 (c) $x = 2$; (d) $x = 1$; (e) $x = 6$ 15. [4.3C] (a) $x = 5$; (b) $x = 10$;
 (c) $x = 20$; (d) $x = 25$; (e) $x = 30$ 16. [4.3D] (a) 9; (b) 18; (c) 36;
 (d) 45; (e) 54 17. [4.4A] (a) 15 lb; (b) $17\frac{1}{2} = 17.5$ lb; (c) 18 lb;
 (d) $22\frac{1}{2} = 22.5$ lb; (e) 25 lb 18. [4.4A] (a) 1800; (b) 2400; (c) 3000;
 (d) 3600; (e) 4800 19. [4.4A] (a) 21 oz; (b) 28 oz; (c) 35 oz; (d) 42 oz;
 (e) 49 oz 20. [4.4A] (a) 200; (b) 400; (c) 350; (d) 450; (e) 600

Cumulative Review Chapters 1–4

1. 9810 2. 2, 7 3. 56 4. 29 5. Improper 6. $9\frac{3}{4}$ 7. $\frac{23}{3}$
 8. $\frac{11}{7}$ 9. $\frac{1}{49}$ 10. $\frac{7}{10}$ 11. $9\frac{4}{15}$ 12. $3\frac{3}{8}$ 13. $c - \frac{7}{9} = \frac{1}{2}$; $c = \frac{23}{18}$
 14. $7\frac{41}{55}$ 15. Two hundred forty-one and thirty-five hundredths
 16. $40 + 4 + \frac{8}{10} + \frac{7}{100} + \frac{4}{1000}$ 17. 46.144 18. 328.92
 19. 0.08310 20. 500 21. 1.450 22. 76.92 23. 0.583 24. $\frac{3}{20}$
 25. $\frac{28}{33}$ 26. 0.75 27. $6.43\overline{5} > 6.43\overline{5} > 6.435$ 28. $>$ 29. 4 30. 7
 31. 62.1 32. $\frac{99}{200}$ 33. $\frac{6}{2} = \frac{54}{x}$ 34. No 35. $j = \frac{1}{5}$ 36. $c = 15$
 37. 100 38. 35 39. 12¢/oz 40. 40 41. 24 42. 800

Chapter 5

Exercises 5.1

1. 0.03 3. 0.10 5. 3.00 7. 0.1225 9. 0.115 11. 0.003 13. 4%
 15. 81.3% 17. 31.4% 19. 100% 21. 0.2% 23. $\frac{3}{10}$ 25. $\frac{3}{50}$ 27. $\frac{7}{100}$

29. $\frac{9}{200}$ 31. $\frac{1}{75}$ 33. $\frac{17}{500}$ 35. $\frac{21}{200}$ 37. 60% 39. 50% 41. $83\frac{1}{3}\%$
 43. $37\frac{1}{2}\%$ 45. $133\frac{1}{3}\%$ 47. 81% 49. 15% 51. (a) $\frac{41}{100}$; 0.41;
 (b) $\frac{33}{100}$; 0.33; (c) $\frac{8}{25}$; 0.32; (d) $\frac{31}{100}$; 0.31 53. (a) $\frac{11}{25}$; 0.44; (b) $\frac{1}{5}$; 0.2;
 (c) $\frac{3}{20}$; 0.15 55. (a) $\frac{7}{10}$; (b) 70%; (c) 0.70 57. (a) $\frac{11}{14}$; (b) 79%; (c) 0.79
 59. (a) 68%; (b) 7%; (c) 19% 61. (a) 50%; (b) 33%; (c) 82%
 63. (a) $\frac{3}{10}$; (b) 30%; (c) 0.30 65. (a) $\frac{13}{25}$; (b) 0.52 67. No; due to
 rounding 69. 70% 71. (a) 40%; (b) $\frac{2}{5}$ 73. (a) $\frac{49}{100}$; (b) 0.49 75. 5%
 77. 1% 81. two, left 83. (a) 100; (b) Reduce; (c) Omit 85. (a) $\frac{41}{50}$;
 (b) 0.82 87. (a) $\frac{13}{200}$; (b) $\frac{131}{2000}$ 89. (a) 6%; (b) 619%; (c) 4220%
 91. (a) 0.38; (b) 0.293 93. 29 95. $x = 40$ 97. $x = \frac{1}{3}$ or $0\bar{3}$

Exercises 5.2

Translate This

1. D 3. M 5. C 7. K 9. L
 1. 32 3. 12 5. \$3 7. 28.8 9. 5 11. 2.1 13. 20 15. 10%
 17. 200% 19. 10% 21. $12\frac{1}{2}\%$ 23. 25% 25. 60 27. 200
 29. $8\frac{1}{3}$ 31. $16\frac{2}{3}$ 33. 200 35. 400 37. 50 39. 45 41. $16\frac{2}{3}$
 43. 18.75 45. 800 47. 3 49. 300 51. 73 million 53. 23
 55. 250 57. (a) 40%; (b) more 59. 900 61. 1200 billion barrels
 63. 1,000,000 short tons 65. (a) 19.7 mpg; (b) 635; (c) 13; (d) \$26,
 \$39, \$52 67. (a) 20.9 mpg; (b) 598; (c) 24; (d) \$48, \$72, \$96
 69. 26% 71. 720 73. 710 75. \$15 77. $7\frac{1}{2}\%$ 79. Three
 81. base 83. percent 85. \$795; \$705 87. 50 89. 60 91. 20
 93. $n = 16$ 95. $W = 50$

Exercises 5.3

1. 24 3. 30 5. \$6 7. 27 9. 7.5 11. 2.1 13. 22 15. 10%
 17. 400% 19. 20% 21. 20% 23. 25% 25. 80 27. 200
 29. $8\frac{1}{3}$ 31. $16\frac{2}{3}$ 33. 300 35. 800 37. 150 39. 90
 41. 35 43. 18.75 45. 1600 47. 49 49. 300 51. 48 53. 80
 55. $t = 432.4$ 57. $t = 302.4$ 59. $h < 30$ in. 61. $h < 32$ in.
 65. $\frac{\text{Percent}}{100}$ 67. 32 69. 600 71. 0.055 73. 0.166

Exercises 5.4

1. \$3640 3. \$13.00 5. \$660; \$13,860 7. 4% 9. \$24
 11. \$30 13. \$37.50 15. \$4.50 17. (a) \$530; (b) \$5300
 19. \$160 21. \$6077.53 23. \$60,775.31 25. \$510.05 27. \$280
 29. \$626 31. \$13.05 33. \$414 35. \$5 37. \$20.08 39. \$12.38
 41. (a) \$13.50; (b) $2 \times 5.40 + \frac{1}{2} \times 5.40$; (c) \$13.50, yes
 43. (a) \$3.72; (b) $2 \times \$3.72 = \7.44 ; (c) $3 \times \$3.72 = \11.16
 45. (a) \$4.64; (b) $2 \times \$4.64 = \9.28 ; (c) $\$4.64 + \frac{1}{2} \times \$4.64 = \$6.96$
 47. \$11,700 49. \$3900 51. \$3050 53. \$8620 55. \$18,620
 57. 20% 59. (a) Move the decimal point left one place 61. principal
 63. year 65. \$9.60; \$70.40 67. \$10,824.32; \$824.32 69. \$128.70
 71. 167% 73. 56% 75. 83%

Exercises 5.5

1. 20% 3. 17% 5. 9% 7. 4% 9. 4% 11. 14% 13. 28%
 15. 338% 17. 158% 19. (a) 30%; (b) 390 21. (a) 243%;
 (b) 343,000 23. (a) 30%; (b) 7800 25. (a) \$10,150; (b) \$7308
 27. (a) 338%; (b) 3%; (c) 12% 29. (a) 8%; (b) 73% 31. 5%, yes
 33. 18%, no 35. -15%, yes 37. 330% 39. yes; \$1400
 45. original 47. 12% 49. 27% 51. 11% 53. \$53.25 55. 3.9
 57. \$1013.38

Exercises 5.6

1. \$90; \$1.35; \$141.35 3. \$109.39; \$1.64; \$185.01 5. \$303.93;
 \$4.56; \$557.48 7. \$200; \$3; \$453 9. (a) \$1.28; (b) \$236.28;
 (c) \$11.81 11. (a) \$5.16; (b) \$409.16; (c) \$20.46 13. (a) \$1.21;
 (b) \$180.39; (c) \$10 15. (a) \$0.84; (b) \$92.73; (c) \$10 17. (a) \$50;
 \$143.12; (b) \$87.50; (c) \$6262.80 19. (a) \$50; (b) \$61; (c) \$3320
 21. (a) \$100; (b) \$122; (c) \$6640 23. (a) \$47,500; (b) \$2500;

- (c) \$38.92; \$277.08 25. (a) \$500; \$99.55; \$99,900.45; (b) \$499.50; \$100.05; \$99,800.40 27. (a) \$875; \$122.95; \$149,877.05; (b) \$874.28; \$123.67; \$149,753.38 29. \$225,000 31. (a) \$144,798; (b) \$269,798 33. \$5.00 35. $\frac{1}{12}$ 37. $\frac{1}{4}$ 39. loan 41. (a) \$1000; (b) \$200 43. (a) \$150; (b) \$2.25; (c) \$212.25; (d) \$10.61 45. 50 47. 700

Review Exercises

1. [5.1A] (a) 0.39; (b) 0.01; (c) 0.13; (d) 1.01; (e) 2.07
 2. [5.1A] (a) 0.032; (b) 0.112; (c) 0.714; (d) 0.1751; (e) 1.425
 3. [5.1A] (a) 0.0625; (b) 0.715; (c) 0.05375; (d) 0.1725; (e) 0.52125
 4. [5.1A] (a) 0.06 $\bar{3}$; (b) 0.08 $\bar{6}$; (c) 0.011 $\bar{6}$; (d) 0.188 $\bar{3}$; (e) 0.20 $\bar{1}$
 5. [5.1B] (a) 1%; (b) 7%; (c) 17%; (d) 91%; (e) 83%
 6. [5.1B] (a) 320%; (b) 110%; (c) 790%; (d) 910%; (e) 432%
 7. [5.1C] (a) $\frac{17}{100}$; (b) $\frac{23}{100}$; (c) $\frac{51}{100}$; (d) $\frac{111}{100}$; (e) $\frac{201}{100}$ 8. [5.1C] (a) $\frac{1}{10}$; (b) $\frac{2}{5}$; (c) $\frac{3}{20}$; (d) $\frac{7}{20}$; (e) $\frac{21}{50}$ 9. [5.1C] (a) $\frac{1}{6}$; (b) $\frac{1}{3}$; (c) $\frac{5}{8}$; (d) $\frac{5}{6}$; (e) $\frac{7}{8}$
 10. [5.1D] (a) 37 $\frac{1}{2}$ %; (b) 62 $\frac{1}{2}$ %; (c) 6 $\frac{1}{4}$ %; (d) 18 $\frac{3}{4}$ %; (e) 31 $\frac{1}{4}$ %
 11. [5.2A] (a) 18; (b) 98; (c) 32; (d) 27; (e) 36.75 12. [5.2A] (a) 10; (b) 24.3; (c) 38.75; (d) 32; (e) 1732.5 13. [5.2B] (a) 25%; (b) 20%; (c) 33 $\frac{1}{3}$ %; (d) 200%; (e) 20% 14. [5.2B] (a) 75%; (b) 40%; (c) 200%; (d) 66 $\frac{2}{3}$ %; (e) 16 $\frac{2}{3}$ % 15. [5.2B] (a) 50%; (b) 33 $\frac{1}{3}$ %; (c) 75%; (d) 150%; (e) 37 $\frac{1}{2}$ % 16. [5.2C] (a) 60; (b) 50; (c) 20; (d) 33 $\frac{1}{3}$; (e) 66 $\frac{2}{3}$ 17. [5.2C] (a) 150; (b) 300; (c) 50; (d) 1500; (e) 84 18. [5.2C] (a) 25; (b) 10; (c) 200; (d) 300; (e) 250
 19. [5.3A] (a) $\frac{30}{100} = \frac{\text{Part}}{40}$; 12; (b) $\frac{40}{100} = \frac{\text{Part}}{72}$; 28.8; (c) $\frac{50}{100} = \frac{\text{Part}}{94}$; 47; (d) $\frac{60}{100} = \frac{\text{Part}}{50}$; 30; (e) $\frac{70}{100} = \frac{\text{Part}}{70}$; 49 20. [5.3B] (a) $\frac{\text{Percent}}{100} = \frac{80}{800}$; 10%; (b) $\frac{\text{Percent}}{100} = \frac{22}{110}$; 20%; (c) $\frac{\text{Percent}}{100} = \frac{28}{70}$; 40%; (d) $\frac{\text{Percent}}{100} = \frac{90}{180}$; 50%; (e) $\frac{\text{Percent}}{100} = \frac{80}{40}$; 200% 21. [5.3C] (a) $\frac{10}{100} = \frac{20}{\text{Whole}}$; 200; (b) $\frac{12}{100} = \frac{30}{\text{Whole}}$; 250; (c) $\frac{90}{100} = \frac{45}{\text{Whole}}$; 50; (d) $\frac{25}{100} = \frac{50}{\text{Whole}}$; 200; (e) $\frac{18}{100} = \frac{63}{\text{Whole}}$; 350
 22. [5.4A] (a) \$21.20; (b) \$52; (c) \$18.90; (d) \$85.20; (e) \$313.50
 23. [5.4B] (a) \$20; (b) \$90; (c) \$90; (d) \$108; (e) \$765
 24. [5.4B] (a) \$10; (b) \$18; (c) \$10; (d) \$27; (e) \$32.50
 25. [5.4C] (a) \$10,824.32; \$824.32; (b) \$11,255.09; \$1255.09; (c) \$11,698.59; \$1698.59; (d) \$12,155.06; \$2155.06; (e) \$12,624.77; \$2624.77 26. [5.4D] (a) \$8; (b) \$15; (c) \$1225; (d) \$19.50; (e) \$38.50 27. [5.4E] (a) \$21; (b) \$20; (c) \$40; (d) \$81; (e) \$459 28. [5.5A] (a) 50%; (b) 55%; (c) 60%; (d) 65%; (e) 70% 29. [5.5A] (a) 1%; (b) 3%; (c) 4%; (d) 5%; (e) 6%
 30. [5.5A] (a) \$56 million; (b) \$64 million; (c) \$66 million; (d) \$80 million; (e) \$88 million 31. [5.6A] (a) \$80; \$1.20; \$131.20; (b) \$120; \$1.80; \$181.80; (c) \$160; \$2.40; \$232.40; (d) \$200; \$3; \$303; (e) \$300; \$4.50; \$604.50 32. [5.6B] (a) \$12.50; \$35.78; \$21.88; \$1566; (b) \$25; \$71.56; \$43.75; \$3130.80; (c) \$37.50; \$107.34; \$65.63; \$4696.80; (d) \$50; \$143.12; \$87.50; \$6262.80; (e) \$62.50; \$178.90; \$109.38; \$7827.60

Cumulative Review Chapters 1–5

1. 6510 2. 40 3. improper 4. $7\frac{3}{4}$ 5. $\frac{58}{9}$ 6. $\frac{1}{36}$ 7. $\frac{6}{35}$ 8. $x - \frac{3}{4} = \frac{1}{3}$; $x = \frac{13}{12}$ 9. $7\frac{37}{45}$ 10. Three hundred forty-two and forty-one hundredths
 11. $30 + 4 + \frac{7}{10} + \frac{7}{100} + \frac{3}{1000}$ 12. 626.92 13. 8.910 14. 700
 15. 749.9 16. 76.92 17. $\frac{4}{33}$ 18. 0.25 19. $4.29\bar{3} > 4.29\bar{3} > 4.293$
 20. $<$ 21. $x = 3.9$ 22. $y = 7$ 23. $z = 21$ 24. $\frac{12}{25}$ 25. $\frac{5}{9} = \frac{40}{x}$
 26. No 27. $f = \frac{1}{4}$ 28. $f = 18$ 29. 19 mpg 30. 12¢/oz 31. 4 lb
 32. 112 oz 33. 0.12 34. 0.0725 35. 3% 36. 8 37. 36 38. 50%
 39. 20 40. \$16.80 41. \$68

Chapter 6

Exercises 6.1

1. Wendy's 3. 69% 5. 22 7. 94 9. Most times 11. Internet
 13. Products, Spiritual 15. Health 17. 50 19. About 22
 21. Administrative 23. Google 25. 145 million 27. 150 million

29. 40 million 31. Newspapers 33. 38.5% 35. 5.3%
 37. Wendy's 39. Jack in the Box 43. table 45. White
 47. \$243.2 billion 49. 7 51. 3 53. 14.5 55. 507.5 57. 25%

Exercises 6.2

1. (a) 10; (b) 16; (c) Medicine 3. (a) About 4; (b) About 5; (c) Medicine
 5. College; \$413 7. \$294 9. (a) 59%; (b) 20%; (c) 145
 11. (a) 20 to 29; (b) <1 ; answers may vary; (c) Less than 50 years old;
 (d) 90+; smaller population 13. (a) 39; (b) 29; (c) 0.20–0.29; 14
 15. (a)

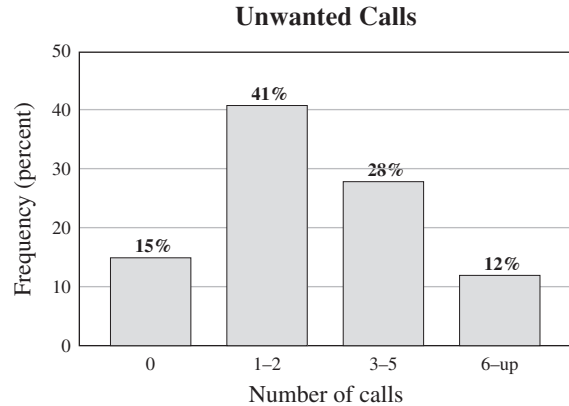

- (b) 1–2; (c) 15
 17. (a)

Daily Travel Expenses

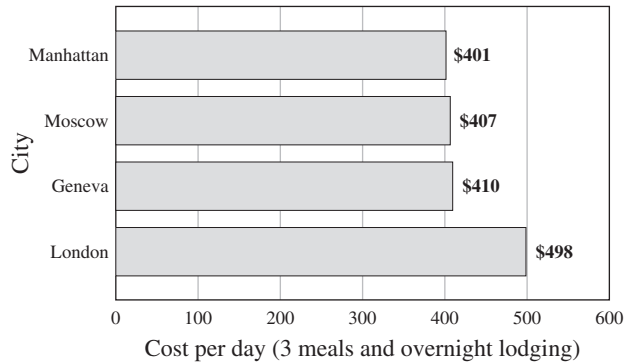

- (b) London; (c) Manhattan; (d) \$97 19. (a) 3 and 4; (b) 5; (c) 5
 21. (a) About 47%; (b) About 33%; (c) About 14%; (d) About 20%;
 (e) 1980–1982 23. (a) About \$1.75; (b) \$2.00; (c) \$2.05;
 (d) At 23 days
 25.

Average Amount of Money Spent on Apparel by Men Between 16 and 25

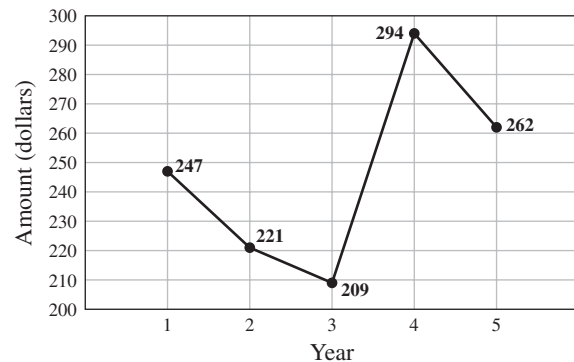

27. **Average Amount of Money Spent on Food by Persons Under 25**

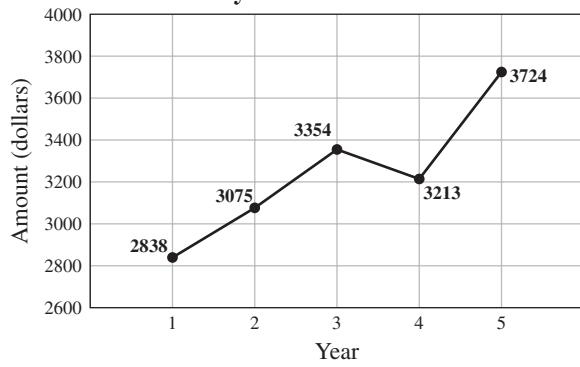

29. **Average Amount of Money Spent on Fresh Fruit by Persons Under 25**

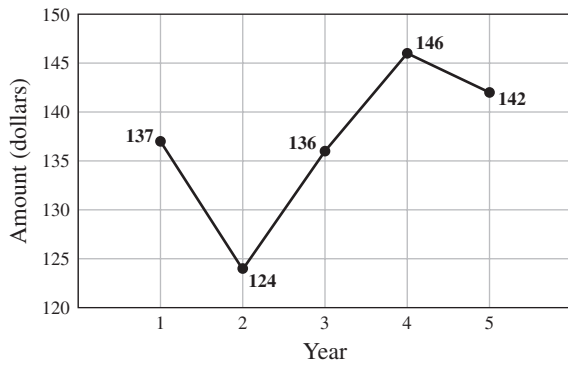

31. **Average Amount of Money Spent on Housing by Persons Under 25**

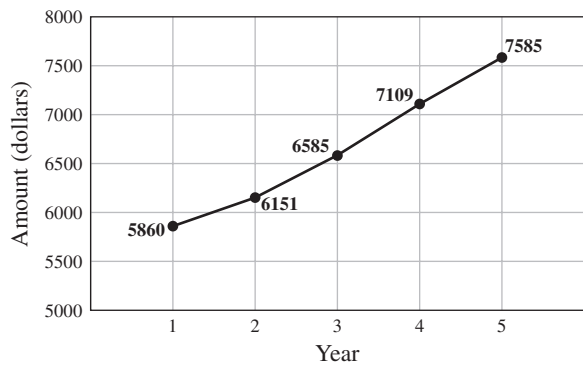

33. **Average Amount of Money Spent on Entertainment by Persons Under 25**

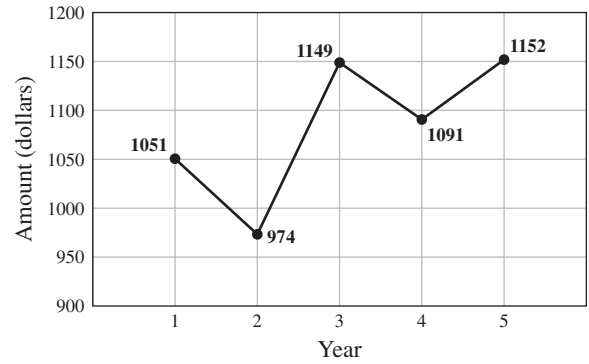

35. **Average Amount of Money Spent on Health Care by Persons Under 25**

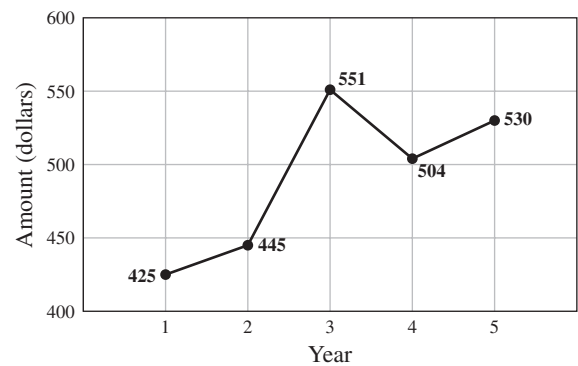

37. **Average Amount of Annual Wages-Salaries Earned by Persons Between 25 and 34**

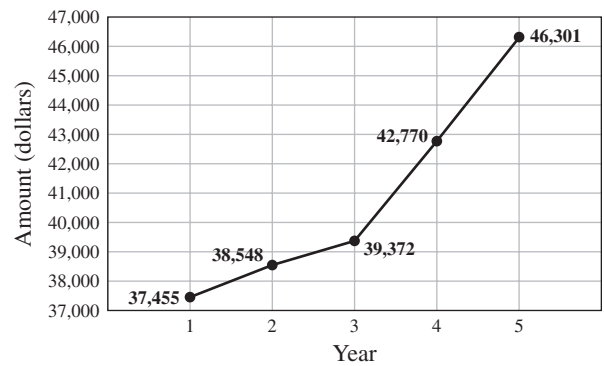

39. **Average Amount of Annual Federal Income Taxes Paid by Persons Between 25 and 34**

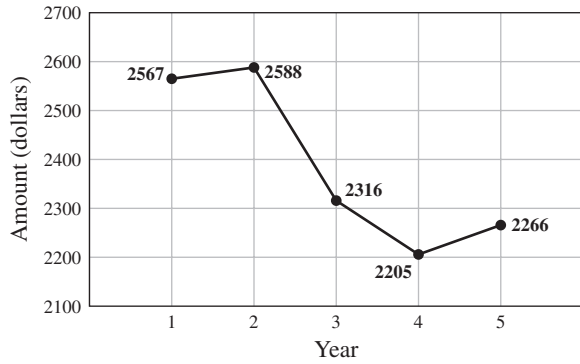

41. 3%; No 45. proportional

47. **Average Amount of Vehicle Insurance Paid by a Driver Less Than 25 Years Old**

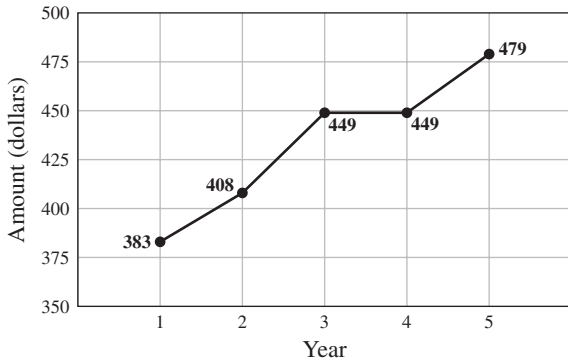

49. **Projected Percent of Age Ranges in the United States for the Year 2050**

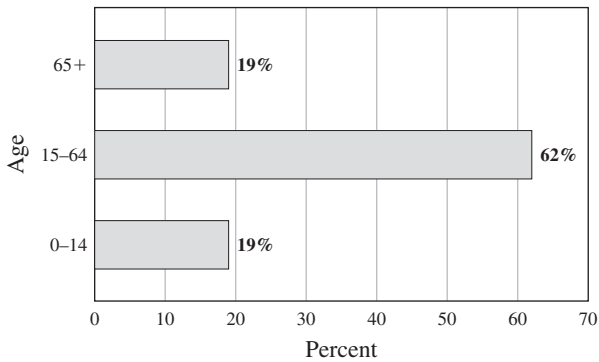

51. (a) 47%; (b) 57%; (c) September 7-10 53. 110 55. 25

Exercises 6.3

1. (a) bus; (b) bike; (c) 71% 3. (a) Cheddar; (b) Swiss; (c) Mozzarella 5. (a) Toilet; (b) 85 gal; (c) Faucet; (d) 30 gal 7. (a) Paper; (b) Yard trimmings; (c) 20 lb; (d) 9 lb 9. (a) Oil; (b) Nuclear; (c) Natural gas 11. Food 13. Books

15. **Family Budget (Monthly)**

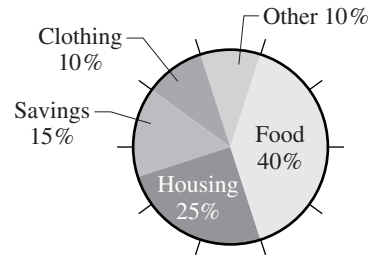

17. **Chores Done by Husbands**

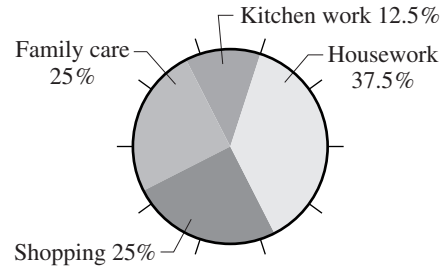

19. **Type of Car Owned by Family with a Car**

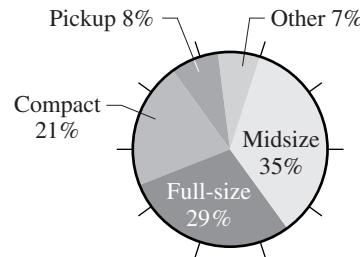

21. **Student Internet Use**

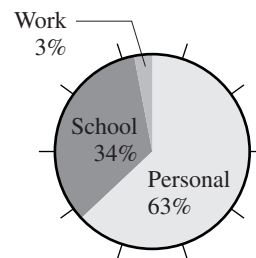

23. **Punishment for Using Unlicensed or Pirated Software**

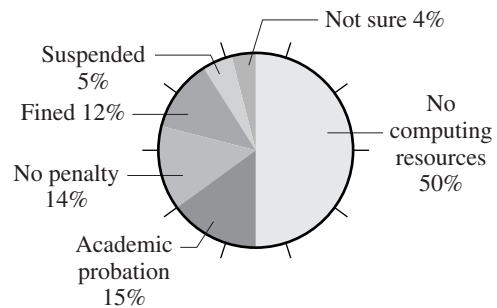

25. 144° 27. 54° 31. circle 33. 34% 35. 65 37. 2.51 39. 1.5

Exercises 6.4

1. 9 3. $15.\overline{16}$ 5. 9 7. 12.5 9. 5 and 52 11. 11
 13. (a) Mean: \$4.61, median: \$4.41, mode: none; (b) no; (c) Answers may vary; (d) Mean and median 15. 1.85 17. (a) Mean: 43,216.40, median: 40,827, mode: none; (b) Median Answers may vary.
 19. (a) Rodriguez \$33,000,000, Ramirez \$24,000,000, Jeter \$22,000,000, Teixeira \$21,000,000, Beltran \$19,000,000, Lee, \$19,000,000, Ordonez \$19,000,000, Santana \$19,000,000, Zambrano \$19,000,000, Zito \$19,000,000; (b) Mean: \$21,400,000, median: \$19,000,000, mode: \$19,000,000; (c) All three are good measures because they are close. (Answers will vary.)
 21. (a) Lidge \$12,000,000, Ortiz \$13,000,000, Silva \$11,000,000, Perez \$12,000,000, Giles \$9,000,000; (b) Mean: \$11.4 million, median: \$12 million, mode: \$12 million; (c) Answers may vary.
 23. Mean: \$51,117.50, Median: \$51,785.50 25. (a) 14.26; (b) 14.26; (c) There is no mode. 27. Mode 31. mean 33. even, median, average 35. mode 37. $22.\overline{2}$ 39. 28 41. Internet 43. 5 45. 2 47. 105

Review Exercises

1. [6.1A] (a) 42%; (b) 39%; (c) \$1514.44; (d) \$1878.16; (e) \$0.01
 2. [6.1B] (a) McDonald's; (b) Wendy's; (c) 200; (d) 550; (e) 100
 3. [6.2A] (a) Ages 18–24; (b) Ages 25–34; (c) 44%; (d) 10%; (e) 37%
 4. [6.2B]

Consumers Who Have Downloaded Music and Said They Purchased More Music

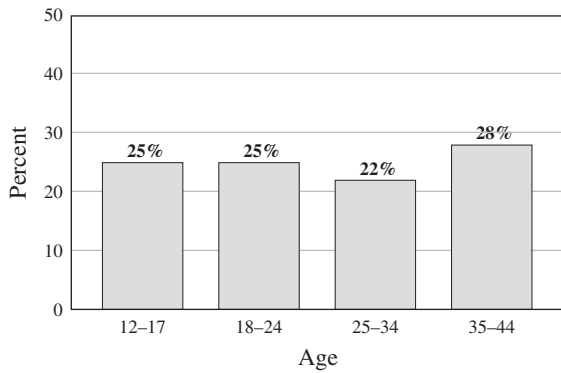

5. [6.2B]

Number of Cell Phone Users by Year

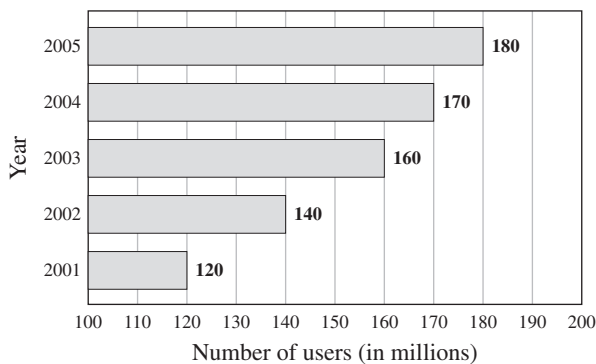

6. [6.2C] (a) About 175,000,000; (b) About 200,000,000; (c) About 250,000,000; (d) About 300,000,000; (e) About 325,000,000
 7. [6.2C] (a) About 12,500,000; (b) About 25,000,000; (c) About 50,000,000; (d) About 75,000,000; (e) About 80,000,000
 8. [6.2D]

Online Spending Forecast for Kids

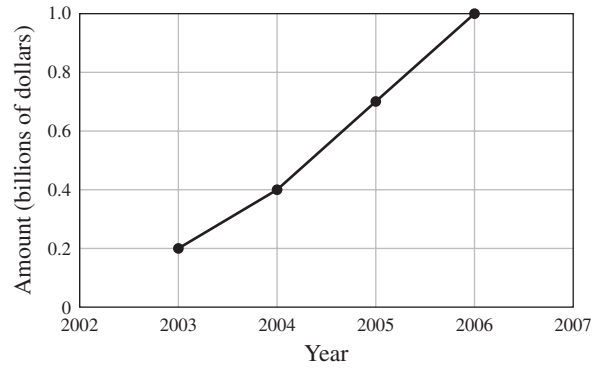

9. [6.3A] (a) 13%; (b) 42%; (c) 22%; (d) Home; (e) 20%
 10. [6.3A] (a) 100; (b) 130; (c) 130; (d) 220; (e) 420
 11. [6.3B]

Ways We Commute to Work

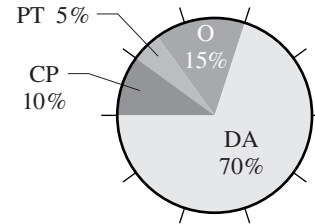

12. [6.4A, B, C] (a) 93 cents; (b) 99 cents; (c) 99 cents; (d) 94 cents; (e) 99 cents 13. [6.4A, B, C] (a) 15 grams; (b) 14 grams; (c) None; (d) 16 grams; (e) 16 grams 14. [6.4A] 2.8 15. [6.4A] 3.0

Cumulative Review Chapters 1–6

1. 6510 2. 7 3. Proper 4. $3\frac{1}{8}$ 5. $\frac{13}{6}$ 6. $\frac{1}{25}$ 7. $\frac{9}{5} = 1\frac{4}{5}$
 8. $z - \frac{3}{4} = \frac{3}{8}$, $z = \frac{9}{8} = 1\frac{1}{8}$ 9. $4\frac{25}{32}$ 10. Three hundred fifty-two and fifty-one hundredths 11. $60 + 4 + \frac{1}{10} + \frac{7}{100} + \frac{5}{1000}$
 12. 528.92 13. 0.7787 14. 600 15. 749.9 16. 615.38 17. $\frac{26}{33}$
 18. 0.3 19. $9.56\overline{8} > 9.5\overline{68} > 9.568$ 20. $<$ 21. 4.2 22. 9
 23. 13.2 24. $\frac{7}{25}$ 25. $\frac{4}{7} = \frac{28}{x}$ 26. Yes 27. $x = \frac{1}{2}$ 28. $p = 15$
 29. 26 mpg 30. 12¢ 31. 4 lb 32. 39 oz 33. 0.67 34. 0.0375
 35. 9% 36. 48 37. 36 38. 50% 39. 30 40. \$18.72 41. \$67.50
 42. 27% 43. About 26 in. 44. 7 degrees 45. 50% 46. 2
 47. 9 48. 18

Chapter 7

Exercises 7.1

1. 144 3. 90 5. 84 7. $4\frac{1}{6}$ 9. 7 11. $\frac{1}{4}$ 13. $\frac{3}{4}$ 15. 10
 17. $12\frac{1}{3}$ 19. 1 21. 48 23. 3 25. 5280 27. 1760 29. 1
 31. (a) $\frac{175}{132} = 1\frac{43}{132}$ mi; (b) $\frac{200}{3} = 66\frac{2}{3}$ yd 33. (a) 30 in.; (b) yes
 35. 4029 yd 37. 265 in. 39. 1 mi 41. 141 in. 43. 64 in.
 45. 10,560 ft/hr 47. (a) 2 yd/sec; (b) 120 yd 49. 23,178; the 4.55-mi = 24,024-ft split 51. 34 yd/sec 53. $33\frac{1}{3}$ ft/sec 55. (a) $833\frac{1}{3}$ yd;

(b) To prove this, you have to know that 1 mile = 1760 yd

(see Problem 27) $\frac{60 \text{ miles}}{\text{hour}} = \frac{60(1760 \text{ yd})}{3600 \text{ sec}} = \frac{(176 \text{ yd})}{6 \text{ sec}} \approx \frac{29 \text{ yd}}{\text{sec}}$;

(c) $\frac{833\frac{1}{3} \text{ yd}}{29 \text{ yd/sec}} \approx 29 \text{ sec}$ **57.** 194,040 ft **63.** U.S., metric **65.** 78
67. 6 **69.** $8\frac{1}{3}$ **71.** $6\frac{1}{4}$ **73.** 4.232 **75.** 8350 **77.** 46.5

Exercises 7.2

1. 5000 **3.** 1.877 **5.** 0.4 **7.** 490 **9.** 1.82 **11.** 2200 **13.** 3000
15. 2.358 **17.** 300 **19.** 6.7 **21.** c **23.** a **25.** b **27.** 0.6 **29.** 160
31. 5000 steps **33.** (a) 110 cm, 320 cm, 150 cm; (b) African elephant: 320 cm, chimp: 110 cm, zebra: 150 cm **35.** 6100 cm **37.** (i) d;
(ii) e; (iii) b; (iv) c; (v) a **41.** substitute **43.** 9240 **45.** 0.3 **47.** 2.3
49. 182.88 **51.** 80 **53.** 4

Exercises 7.3

1. 121.92 **3.** 27.42 **5.** 144 **7.** 8 **9.** 660 **11.** 6.2 **13.** 89.6
15. 9700 **17.** 62 **19.** 36-24-36 **21.** 2.8 in. per century **23.** 2.54 cm
25. 67.1 yards **27.** 20 inches **29.** 17.78 cm; 55.88 cm **31.** 4.154
33. 5.664 **35.** 1.178 or about 1.2 **37.** 24 **39.** larger **41.** smaller
43. 24.8 **45.** 96 **47.** 2.179 **49.** 731.2 **51.** 240 **53.** 12.4
55. 3 **57.** 9.88

Exercises 7.4

1. 3,000,000 **3.** 288 **5.** 3 **7.** 6 **9.** 9680 **11.** 7.41 **13.** 20,000
15. 17,139 **17.** 8,373,200 **19.** (a) 1500; (b) $166\frac{2}{3}$ **21.** 2.87
23. 2.96 **25.** 5214 **27.** 325,000,000 square meters **29.** 0.113 km²
31. $14\frac{2}{3}$ **33.** 9000 **35.** 3 **37.** One square meter. **39.** 6 **41.** 432
43. 9.88 **45.** 48,400 **47.** $2\frac{1}{12}$

Exercises 7.5

1. 3 **3.** 2 **5.** 2 **7.** 20 **9.** 8 **11.** 0.177 **13.** 3.847 **15.** 2.05
17. 5.5 **19.** 60 **21.** 700 **23.** 6000 **25.** 500 **27.** 4000 **29.** 900
31. (a) 0.2 L; (b) 1.8 L **33.** 1.5 **35.** 5 **37.** 10 **39.** 480 **41.** 450
43. 15 **45.** 8 **47.** (a) 50 fl oz per day; (b) $6\frac{1}{4}$ cups per day
49. (a) 3120 mL; (b) 104 fl oz **51.** 534.5 gallons **53.** (a) 8.5 billion gallons; (b) 14.25 billion gallons **55.** 33.2 L **57.** (a) 16; (b) 3.2;
(c) 4.6875 **61.** cm **63.** (a-b) 750 **65.** 1.25; 240 **67.** 10,000
69. 5 **71.** 2.7

Exercises 7.6

1. 48 **3.** 72 **5.** 4 **7.** 4.5 **9.** 8000 **11.** 5000 **13.** 1.5 **15.** 2
17. 200,000 **19.** 200 **21.** 200 **23.** 50 **25.** 0.899 **27.** 0.030
29. 0.57 **31.** 8.8 **33.** 22 **35.** 0.9 **37.** 100 **39.** 0.45 **41.** 15
43. 25 **45.** 45 **47.** 50 **49.** 95 **51.** 1832 **53.** 40 **55.** 72
57. 158 **59.** $52 \times 2.2 \approx 114$ **61.** 100 to 200 **63.** 23,949
65. 109.4°F **67.** 40°C **69.** 15°C; 59°F **71.** 18°C; 64°F
73. 3°C; 5°F **77.** gram **79.** 104° **81.** 17.6 **83.** 0.384 **85.** 6
87. 10 **89.** 130 **91.** 74

Review Exercises

1. [7.1A] (a) 72; (b) 108; (c) 144; (d) 216; (e) 252 **2.** [7.1A] (a) 1;
(b) 2; (c) 3; (d) $3\frac{1}{3}$; (e) $5\frac{5}{12}$ **3.** [7.1A] (a) $\frac{1}{6}$; (b) $\frac{1}{4}$; (c) $\frac{5}{12}$; (d) $\frac{7}{12}$; (e) $\frac{1}{6}$
4. [7.1A] (a) 2; (b) 4; (c) 6; (d) $6\frac{2}{3}$; (e) $9\frac{2}{3}$ **5.** [7.1A] (a) 1; (b) 2; (c) 5;
(d) 4; (e) 3 **6.** [7.2A] (a) 2000; (b) 7000; (c) 4600; (d) 450; (e) 45,000
7. [7.2A] (a) 20; (b) 30; (c) 70; (d) 90; (e) 100 **8.** [7.2A] (a) 1000;
(b) 3000; (c) 3500; (d) 4500; (e) 6000 **9.** [7.2A] (a) 2; (b) 3.95;
(c) 4.05; (d) 2.34; (e) 4.99 **10.** [7.3A] (a) 76.2; (b) 101.6; (c) 1524;
(d) 1828.8; (e) 2133.6 **11.** [7.3A] (a) 91.4; (b) 182.8; (c) 319.9;
(d) 411.3; (e) 457 **12.** [7.3A] (a) 48; (b) 80; (c) 144; (d) 160;
(e) 400 **13.** [7.3A] (a) 24.8; (b) 31; (c) 37.2; (d) 43.4; (e) 49.6
14. [7.4A] (a) 20,000; (b) 30,000; (c) 40,000; (d) 50,000;
(e) 60,000 **15.** [7.4A] (a) 2,000,000; (b) 3,000,000; (c) 4,000,000;
(d) 5,000,000; (e) 6,000,000 **16.** [7.4B] (a) 288; (b) 432; (c) 576;
(d) 720; (e) 864 **17.** [7.4B] (a) 1; (b) 2; (c) 2.5; (d) 3; (e) 3.5

18. [7.4B] (a) 4840 yd²; (b) 14,520 yd²; (c) 9680 yd²; (d) 7260 yd²;
(e) 19,360 yd² **19.** [7.4C] (a) 12.35; (b) 9.88; (c) 2.47; (d) 7.41;
(e) 4.94 **20.** [7.5A] (a) 7; (b) 9; (c) 10; (d) 13; (e) 2.2 **21.** [7.5B]
(a) 4000; (b) 7000; (c) 9000; (d) 2300; (e) 5970 **22.** [7.5B] (a) 0.452;
(b) 0.048; (c) 0.003; (d) 1.657; (e) 0.456 **23.** [7.5C] (a) 960;
(b) 1200; (c) 1440; (d) 1680; (e) 2160 **24.** [7.5C] (a) 0.5; (b) 1.5;
(c) 2; (d) 2.5; (e) 3 **25.** [7.5C] (a) 3600; (b) 5400; (c) 7200; (d) 9000;
(e) 10,800 **26.** [7.5C] (a) 105; (b) 120; (c) 50; (d) 55; (e) 65
27. [7.6A] (a) 48; (b) 64; (c) 80; (d) 96; (e) 112 **28.** [7.6A]
(a) 1; (b) 1.5; (c) 2; (d) 2.5; (e) 3 **29.** [7.6A] (a) 4000; (b) 6000;
(c) 8000; (d) 10,000; (e) 12,000 **30.** [7.6A] (a) 1.5; (b) 2.5; (c) 3.5;
(d) 4.5; (e) 9 **31.** [7.6B] (a) 100; (b) 300; (c) 500; (d) 400; (e) 200
32. [7.6B] (a) 0.307; (b) 0.040; (c) 3.245; (d) 0.002; (e) 10.342
33. [7.6C] (a) 2.2; (b) 15.4; (c) 13.2; (d) 8.8; (e) 17.6 **34.** [7.6C]
(a) 0.45; (b) 1.35; (c) 2.7; (d) 1.8; (e) 4.5 **35.** [7.6D] (a) 0; (b) 5;
(c) 10; (d) 15; (e) 100 **36.** [7.6D] (a) 50; (b) 59; (c) 68; (d) 77; (e) 86

Cumulative Review Chapters 1-7

1. 2910 **2.** 6 **3.** $5\frac{1}{6}$ **4.** $\frac{13}{3}$ **5.** 727.92 **6.** 0.08048 **7.** 549.9
8. 384.62 **9.** 0.25 **10.** $y = 4$ **11.** $z = 35.1$ **12.** No **13.** $\frac{1}{3}$ **14.** 45 oz
15. 0.12 **16.** 0.0725 **17.** 20 **18.** 2 **19.** 50% **20.** 20 **21.** \$212.50
22. Buses and trucks

23.

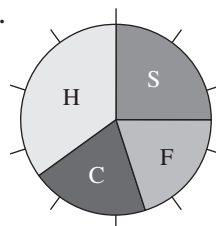

24. 43% **25.** About 34 in. **26.** 5 degrees **27.** 30% **28.** 6 **29.** 8
30. 25 **31.** 432 in. **32.** $1\frac{5}{12}$ ft **33.** $15\frac{2}{3}$ yd **34.** 5 mi **35.** 96 in.
36. 2000 m **37.** 50 m **38.** 1500 dm **39.** 45.7 m **40.** 105.6 km
41. 62 mi **42.** 19,360 yd² **43.** 14.82 acres

Chapter 8

Exercises 8.1

1. Ray \overrightarrow{RS} **3.** Line segment \overline{TU} or \overline{UT} **5.** Line \overleftrightarrow{PQ} or \overleftrightarrow{QP}
7. Line $\overleftrightarrow{CD} \parallel \overleftrightarrow{EF}$ **9.** Line \overleftrightarrow{EF} intersects line \overleftrightarrow{CD} at point G.
11. $\angle \delta$, $\angle P$, $\angle QPR$ or $\angle RPQ$ **13.** $\angle BAC$ or $\angle CAB$
15. $\angle EAF$ or $\angle FAE$ **17.** Acute **19.** Right **21.** Straight
23. $\angle DAB$, $\angle DAF$ **25.** $\angle FAB$ **27.** $\angle DAE$ **29.** $\angle CAD$
31. $\angle EAB$ **33.** 75° **35.** 55° **37.** Scalene right **39.** Scalene acute
41. Isosceles acute **43.** Scalene obtuse **45.** 55° **47.** 15° **49.** 25°
51. 90° **53.** Acute **55.** Acute **57.** Obtuse **59.** Acute **61.** 45°
63. Obtuse, Acute **65.** Isosceles acute **67.** (a) Straight angle, 180°;
(b) Acute angle, 79.2°; (c) Acute angle, 68.4°; (d) Acute angle, 32.4°
69. 45° **71.** 138° **73.** Rap **75.** 3 **77.** 90° **79.** 36° **81.** A ray has
an endpoint, a line does not have an endpoint. **83.** No **89.** line
91. \parallel **93.** angle **95.** straight **97.** obtuse **99.** Supplementary
101. P, Q, M **103.** \overline{PQ} , \overline{ON} , and \overline{NM} **105.** \overline{PN} **107.** (a) Obtuse
scalene; (b) Right isosceles; (c) Acute equilateral; (d) Acute isosceles
109. 145° **111.** $\angle \theta$, $\angle C$, $\angle DCE$ or $\angle ECD$ **113.** 16.6 **115.** 13

Exercises 8.2

1. 20 ft **3.** 8.6 cm **5.** $16\frac{3}{4}$ in. **7.** 21 cm **9.** $17\frac{1}{3}$ yd **11.** 9 ft
13. $11\frac{11}{12}$ yd **15.** $7\frac{1}{4}$ ft **17.** 78.6 m **19.** 98.6 km **21.** 9.42 cm
23. 10.99 ft **25.** 13.188 m **27.** 7.536 mi **29.** 1110 m **31.** 4404.8 ft
33. 102.8 in. **35.** 188.4 cm **37.** 260 in. **39.** 94.20 in. **41.** 489 mi
43. 564 mi **47.** circumference **49.** 2512 million km **51.** 21 cm
53. 9.2 cm **55.** 21 ft **57.** 150 **59.** $\frac{15}{2}$

Exercises 8.3

1. 150 ft^2 3. 6 in.^2 5. 72 cm^2 7. 81 in.^2 9. 81 yd^2 11. 28 cm^2
 13. 175 mm^2 15. 10 ft^2 17. 30 in.^2 19. 20 km^2 21. 15 in.^2
 23. $13\frac{3}{4} \text{ cm}^2$ 25. 60 m^2 27. 45 yd^2 29. $11\frac{1}{2} \text{ in.}^2$ 31. 5625 ft^2
 33. 195 ft^2 35. 50.24 in.^2 37. 153.86 cm^2 39. 3.14 m^2
 41. 24 ft^2 43. 28 ft^2 45. 30 ft^2 47. 957 cm^2 49. 3.87 cm^2
 51. 8100 ft^2 53. 5024 ft^2 55. $21,226,400 \text{ ft}^2$ 57. 113.04 m^2
 59. 314.00 in.^2 61. 1256.00 ft^2 63. 14.13 ft^2 65. 2289.06 ft^2
 67. 792 yd^2 69. 3.403 km^2 71. 15 in.^2 73. 27.56 in.^2 75. 3 in.^2
 77. Two small pizzas 79. *LW* 81. *bh* 83. $11,304 \text{ ft}^2$ 85. 18 cm^2
 87. 100 cm^2 89. 24 m^2 91. $\frac{10}{3}$ 93. 220

Exercises 8.4

1. 240 cm^3 3. $128\frac{1}{4} \text{ in.}^3$ 5. 7904 in.^3 7. 440 in.^3 9. 120 yd^3
 11. 1350 gal 13. 8 gal 15. 2512.0 in.^3 17. 6280.0 cm^3
 19. 31.8 m^3 21. 3.14 ft^3 23. 35.33 in.^3 25. $12,560.0 \text{ ft}^3$
 27. 28.3 in.^3 ; 17 fl oz 29. $434,073.6 \text{ gal}$ 31. $6,782,400.0 \text{ gal}$
 33. 628.0 in.^3 35. $52,333.3 \text{ ft}^3$ 37. 0.5 m^3 39. 76.9 cm^3
 41. $11,134,944 \text{ ft}^3$ 43. (a) 1232 ft^3 ; (b) 63 ft^3 ; (c) No; $1300 > 1295$
 45. (a) $20,569.1 \text{ in.}^3 \approx 11.9 \text{ ft}^3$; (b) $10,284.6 \text{ in.}^3 \approx 6 \text{ ft}^3$
 47. (a) $17,280 \text{ in.}^3 = 10 \text{ ft}^3$; (b) $11,520 \text{ in.}^3 \approx 6.7 \text{ ft}^3$
 49. $14,130,000 \text{ ft}^3$ 51. 0.9 ft^3 53. 63.6 ft^3 55. 7.9 buildings
 57. 100.5 in.^3 59. 25.1 in.^3 63. *LWH* 65. $\frac{4}{3}\pi r^3$ 67. 376.8 cm^3
 69. 38.8 in.^3 71. 25.1 in.^3 73. 185

Exercises 8.5

1. 10 3. 14 5. 19 7. 20 9. 13 11. 2.828 13. 3.317
 15. 4.796 17. 5.385 19. 10.392 21. 11.662 23. 15 25. 20
 27. 47.170 29. 45.122 31. 12 in. 33. 12 in. 35. 2.236 ft
 37. 4.472 m 39. 0.533 m 41. 247.024 ft 43. 175 ft
 45. 17.804 cm 47. 126 ft 49. 310 ft 51. (a) $5\frac{1}{11}$; (b) $5\frac{3}{11}$;
 (c) $5\frac{5}{11}$ 55. $a^2 + b^2 = c^2$ 57. 8.660 59. 7.810 61. 4.583
 63. 13 65. 4 67. 14

Review Exercises

1. [8.1A] (a) \overline{A} ; (b) \overline{B} ; (c) \overline{C} ; (d) \overline{D} ; (e) \overline{E} 2. [8.1A] (a) \overline{AB} ; (b) \overline{EC}
 3. [8.1A] (a) \overline{AB} ; (b) \overline{AD} ; (c) \overline{DB} ; (d) \overline{ED} ; (e) \overline{DC}
 4. [8.1A] \overline{AB} and \overline{EC} 5. [8.1A] (a) \overline{AD} ; (b) \overline{BD} (Answers may vary.)
 6. [8.1B] (a) $\angle \alpha$, $\angle A$, $\angle CAB$ or $\angle BAC$; (b) $\angle \delta$, $\angle D$, $\angle EDF$ or $\angle FDE$; (c) $\angle \gamma$, $\angle G$, $\angle HGI$ or $\angle IGH$; (d) $\angle \xi$, $\angle J$, $\angle KJL$ or $\angle LJK$;
 (e) $\angle \mu$, $\angle M$, $\angle NMO$ or $\angle OMN$ 7. [8.1C] (a) Acute; (b) Acute;
 (c) Right; (d) Straight; (e) Obtuse 8. [8.1D] (a) 80° ; (b) 75° ; (c) 70° ;
 (d) 60° ; (e) 10° 9. [8.1D] (a) 170° ; (b) 165° ; (c) 160° ; (d) 150° ;
 (e) 100° 10. [8.1E] (a) Acute equilateral; (b) Acute isosceles;
 (c) Right isosceles; (d) Obtuse scalene; (e) Right scalene
 11. [8.1F] (a) 110° ; (b) 90° ; (c) 70° ; (d) 50° ; (e) 30°
 12. [8.2A] (a) 16.6 m; (b) 14.6 cm; (c) 15.2 in.; (d) 18.6 yd;
 (e) 20.6 ft 13. [8.2A] (a) 15 m; (b) 19 yd; (c) 15 ft; (d) 17 cm;
 (e) 12 in. 14. [8.2B] (a) 37.68 cm; (b) 50.24 cm; (c) 62.8 in.;
 (d) 75.36 in.; (e) 87.92 ft 15. [8.3A] (a) 30 m^2 ; (b) 56 m^2 ;
 (c) 24 in.^2 ; (d) 21 in.^2 ; (e) 108 in.^2 16. [8.3B] (a) 60 in.^2 ; (b) 40 in.^2 ;
 (c) 24 cm^2 ; (d) 12 m^2 ; (e) 4 m^2 17. [8.3C] (a) 6 in.^2 ; (b) 7.5 cm^2 ;
 (c) 8 m^2 ; (d) 35 ft^2 ; (e) 64 m^2 18. [8.3D] (a) 8 in.^2 ; (b) 60 ft^2 ;
 (c) 12 m^2 ; (d) 15 cm^2 ; (e) 28 m^2 19. [8.3E] (a) 153.86 in.^2 ;
 (b) 3.14 cm^2 ; (c) 28.26 in.^2 ; (d) 12.56 ft^2 ; (e) 78.5 yd^2
 20. [8.4A] (a) 84 cm^3 ; (b) 60 cm^3 ; (c) 40 cm^3 ; (d) 90 cm^3 ;
 (e) 70 cm^3 21. [8.4B] (a) 18.84 in.^3 ; (b) 21.98 in.^3 ; (c) 25.12 in.^3 ;
 (d) 113.04 in.^3 ; (e) 125.60 in.^3 22. [8.4C] (a) 904.32 in.^3 ;
 (b) 1436.03 in.^3 ; (c) 2143.57 in.^3 ; (d) 3052.08 in.^3 ; (e) 4186.67 in.^3
 23. [8.4D] (a) 1570 in.^3 ; (b) 803.84 in.^3 ; (c) 339.12 in.^3 ;
 (d) 100.48 in.^3 ; (e) 12.56 in.^3 24. [8.4E] (a) $1,764,000 \text{ m}^3$;
 (b) $1,866,240 \text{ m}^3$; (c) $1,936,000 \text{ m}^3$; (d) $1,953,640 \text{ m}^3$;
 (e) $2,025,000 \text{ m}^3$ 25. [8.5A] (a) 5; (b) 3; (c) 11; (d) 15; (e) 13
 26. [8.5A] (a) 1.414; (b) 2.828; (c) 3.464; (d) 4.690; (e) 4.123

27. [8.5B] (a) 13 cm; (b) 5 cm; (c) 15 cm; (d) 20 cm; (e) 25 cm
 28. [8.5B] (a) 3.606 cm; (b) 4.472 cm; (c) 6.403 cm;
 (d) 6.708 cm; (e) 7.071 cm 29. [8.5B] (a) 4; (b) 6.928;
 (c) 7.483; (d) 8; (e) 8.944

Cumulative Review Chapters 1–8

1. 10 2. 727.92 3. 750 4. 307.69 5. $y = 6$ 6. $z = 17.6$
 7. $j = \frac{1}{5}$ 8. 0.89 9. 45 10. 25% 11. 60 12. \$78 13. Automobiles
 14.

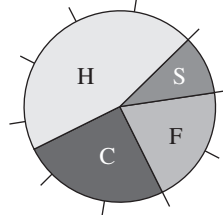

15. 10% 16. 5 degrees 17. 40% 18. 18 19. 20 20. 21
 21. 396 in. 22. $\frac{3}{4} \text{ ft}$ 23. $2\frac{1}{3} \text{ yd}$ 24. 60 in. 25. 4000 m 26. 20 m
 27. 1400 dm 28. $48,400 \text{ yd}^2$ 29. 15.8 in. 30. 37.68 cm
 31. 120 cm^2 32. 200.96 cm^2 33. 168 in.^2 34. 72 cm^3
 35. 904.32 in.^3 36. Acute 37. 125° 38. 60 39. $c = 5$

Chapter 9

Exercises 9.1

1. (a) 0, 1, 3; (b) 1, 3 3. $-5, -2, 0, 1, 3$ 5. Indicates change in
 population since the year 2000 7. (a) +\$50 million (or \$50 million);
 (b) -\$30 million

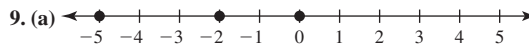

- (b) $>$, $>$ 11. 0 13. 17 15. 2 17. 11 19. 30 21. 3
 23. -1 25. 4 27. -6 29. 0 31. 2 33. 7 35. 5 37. -13
 39. 8 41. -11 43. -20 45. -4 47. 12 49. 4 51. 16,000 ft
 53. 73°C 55. 3500°C 57. 145°F 59. ninth floor 61. +19; 525
 63. +53; 559 65. 4 67. 0 69. 2065 71. 2060 73. (a) 36 ft;
 (b) 11 ft; (c) 25 ft 75. +\$800 billion 77. 2004 79. 799
 81. 284 83. 2262 89. -1, -2, -3, ... 91. $b > a$ 93. distance
 95. add 97. (a) 8; (b) 4; (c) 0 99. -2 101. (a) -12; (b) -4;
 (c) 4 103. (a) MySpace, about 14; (b) Facebook, almost 18
 105. (a) +80 points or 80 points; (b) -\$100,000



109. $>$ 111. 25 113. 72

Exercises 9.2

1. 32 3. -56 5. -10 7. 20 9. 70 11. 5 13. -4 15. -5
 17. -10 19. -20 21. 7 23. 14 25. 0 27. 0 29. Not defined
 31. 16 33. -25 35. -216 37. 81 39. -125 41. 60 43. 40
 45. -30 47. 120 49. -48 51. \$2 53. 15 gain 55. 100 gain
 57. \$30 59. \$250 61. $5(-4)$; -20°F 63. $15(-4)$; -60°F
 65. $5(-7)$; -35°C 67. $70^\circ\text{F} - 14(4)$ or $70^\circ\text{F} + 14(-4)$; 14°F
 69. -22°C 71. -3 73. 0 75. 0 79. positive 81. 0
 83. (a) 100; (b) -100 85. (a) 6; (b) -4; (c) -3; (d) 4 87. (a) 60;
 (b) -30 89. $\frac{9}{5}$ 91. $\frac{10}{7}$ 93. 2.56 95. 0.07 or $\frac{7}{100}$ 97. 0.8 or $\frac{4}{5}$

Exercises 9.3

1. $-\frac{7}{3}$ 3. 6.4 5. $-3\frac{4}{7}$ 7. $\frac{4}{5}$ 9. 3.4 11. $1\frac{1}{2}$ 13. -4.7
 15. -5.4 17. -8.6 19. $\frac{3}{7}$ 21. $-\frac{1}{2}$ 23. $-\frac{1}{12}$ 25. $\frac{7}{12}$ 27. $-\frac{13}{21}$
 29. $-\frac{31}{18}$ 31. -2.6 33. 5.2 35. -3.7 37. $\frac{4}{7}$ 39. $-\frac{29}{12}$ 41. -7.26
 43. 2.86 45. $-\frac{25}{42}$ 47. $\frac{1}{4}$ 49. $-\frac{15}{4}$ 51. (a) $-\frac{21}{20}$; (b) $-\frac{28}{9}$ 53. (a) $-\frac{5}{7}$;
 (b) $-\frac{3}{2}$ 55. (a) $\frac{1}{6}$; (b) 7 57. \$2.05 59. \$56

	61.	63.	65.	67.
	$\sqrt{16}$	0	3	0.68
Natural number	✓		✓	
Whole number	✓	✓	✓	
Integer	✓	✓	✓	
Rational number	✓	✓	✓	✓
Irrational number				
Real number	✓	✓	✓	✓

69. \mathbb{C} , natural number, whole number 71. \mathbb{C} , integer, rational number 73. -1.35 75. -3.045 77. 5.425 81. $-a$ 83. positive 85. $\frac{b}{a}, a \neq 0$ 87. $-\frac{13}{10}$ 89. $1\frac{1}{5}$ 91. $\frac{6}{17}$ 93. $7\frac{9}{11}$ 95. -0.3 97. -3.5 99. $\frac{1}{30}$ 101. -9.5 103. $-\frac{7}{24}$ 105. 6.24 107. $-\frac{1}{2}$ 109. $\frac{9}{7}$ 111. -2 113. 0.25 or $\frac{1}{4}$ 115. (a) (b) (c) (d)

	3.2	$-\frac{8}{9}$	9	$\sqrt{21}$
Natural number			✓	
Whole number			✓	
Integer			✓	
Rational number	✓	✓	✓	
Irrational number				✓
Real number	✓	✓	✓	✓

117. 58 119. 4

Exercises 9.4

1. 2 3. -4 5. -17 7. 17 9. 59 11. 22 13. -1 15. 1 17. 0 19. -22 21. 1 23. -24 25. -33 27. 11,800 29. -1 31. -31 33. 36 35. 87 37. 160 39. (a) 78.5 in.^2 ; (b) 10.2 cents 41. (a) 153.86 in.^2 ; (b) 8.1 cents 43. One possible answer: $3 + 2 \cdot 5 + 6$ 45. One possible answer: $1 + (2 - 3 - 4 - 5 + 6 + 7 + 8) \cdot 9$ 47. No 51. exponent 53. division 55. subtraction 57. -12 59. -21 61. -5 63. 119 65. 45 67. 30

Review Exercises

1. [9.1A] (a) $-6, -4, -1$; (b) 2, 5; (c) 0, 2, 5; (d) 2, 5; (e) $-6, -4, -1, 0, 2, 5$ 2. [9.1A] (a) Price changes in financial markets; (b) Outdoor temperature; (c) Highest, lowest points in North America; (d) Elevations in New Orleans; (e) Estimated population changes from 2000 to 2050 (in millions) 3. [9.1A] (a) 129°F ; (b) -63°C ; (c) $-\$53$; (d) $-\$8$ trillion; (e) $-10,897 \text{ m}$ 4. [9.1A]

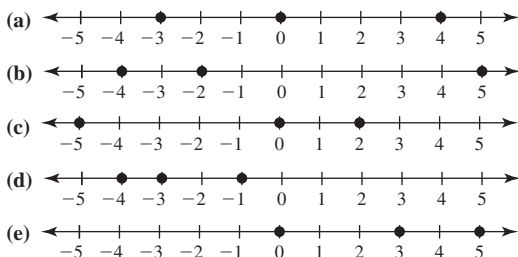

5. [9.1A] (a) $<$; (b) $>$; (c) $<$; (d) $<$; (e) $>$ 6. [9.1B] (a) -10 ; (b) -11 ; (c) -12 ; (d) -13 ; (e) -14 7. [9.1B] (a) 9; (b) 8; (c) 7; (d) 6; (e) 5 8. [9.1C] (a) 7; (b) 8; (c) 9; (d) 10; (e) 11 9. [9.1E] (a) -13 ; (b) -12 ; (c) -11 ; (d) -10 ; (e) -9 10. [9.1E] (a) -7 ; (b) -6 ; (c) -5 ; (d) -4 ; (e) -3

11. [9.1E] (a) 10; (b) 9; (c) 8; (d) 7; (e) 6 12. [9.1F] (a) -18 ; (b) -19 ; (c) -20 ; (d) -21 ; (e) -22 13. [9.1F] (a) -8 ; (b) -7 ; (c) -9 ; (d) -6 ; (e) -5 14. [9.1F] (a) -5 ; (b) -6 ; (c) -7 ; (d) -8 ; (e) -9 15. [9.2A] (a) -24 ; (b) -30 ; (c) -36 ; (d) -42 ; (e) -48 16. [9.2A] (a) 40; (b) 48; (c) 56; (d) 64; (e) 72 17. [9.2A] (a) -25 ; (b) -30 ; (c) -35 ; (d) -40 ; (e) -45 18. [9.2A] (a) -29 ; (b) -24 ; (c) -19 ; (d) -14 ; (e) -9 19. [9.2A] (a) -6 ; (b) -4 ; (c) -3 ; (d) -2 ; (e) -1 20. [9.2A] (a) 3; (b) 5; (c) 7; (d) 9; (e) 11 21. [9.2B] (a) 16; (b) 25; (c) 36; (d) 49; (e) 64 22. [9.2B] (a) -16 ; (b) -25 ; (c) -36 ; (d) -49 ; (e) -64 23. [9.3A] (a) $-\frac{3}{11}$; (b) $-\frac{4}{11}$; (c) $-\frac{5}{11}$; (d) $-\frac{6}{11}$; (e) $-\frac{7}{11}$ 24. [9.3A] (a) 3.4; (b) 4.5; (c) 5.6; (d) 6.7; (e) 7.8 25. [9.3A] (a) $3\frac{1}{2}$; (b) $4\frac{1}{2}$; (c) $5\frac{1}{2}$; (d) $6\frac{1}{2}$; (e) $7\frac{1}{2}$ 26. [9.3B] (a) $\frac{2}{11}$; (b) $\frac{3}{11}$; (c) $\frac{4}{11}$; (d) $\frac{5}{11}$; (e) $\frac{6}{11}$ 27. [9.3B] (a) $3\frac{1}{4}$; (b) $4\frac{1}{4}$; (c) $5\frac{1}{4}$; (d) $6\frac{1}{4}$; (e) $7\frac{1}{4}$ 28. [9.3B] (a) 5.1; (b) 6.2; (c) 7.3; (d) 8.4; (e) 9.5 29. [9.3C] (a) -5.6 ; (b) -5.5 ; (c) -5.4 ; (d) -5.3 ; (e) -5.2 30. [9.3C] (a) -3.1 ; (b) -3.2 ; (c) -3.3 ; (d) -3.4 ; (e) -3.5 31. [9.3C] (a) -5.3 ; (b) -5.4 ; (c) -5.5 ; (d) -5.6 ; (e) -5.7 32. [9.3C] (a) $\frac{2}{11}$; (b) $\frac{3}{11}$; (c) $\frac{4}{11}$; (d) $\frac{5}{11}$; (e) $\frac{6}{11}$ 33. [9.3C] (a) $-\frac{1}{45}$; (b) $-\frac{11}{45}$; (c) $-\frac{16}{45}$; (d) $-\frac{26}{45}$; (e) $-\frac{31}{45}$ 34. [9.3D] (a) -2.8 ; (b) -2.7 ; (c) -2.6 ; (d) -2.5 ; (e) -2.4 35. [9.3D] (a) 4.3; (b) 4.4; (c) 4.5; (d) 4.6; (e) 4.7 36. [9.3D] (a) $\frac{5}{11}$; (b) $\frac{6}{11}$; (c) $\frac{7}{11}$; (d) $\frac{8}{11}$; (e) $\frac{9}{11}$ 37. [9.3D] (a) $-\frac{13}{6}$; (b) $-\frac{5}{2}$; (c) $-\frac{19}{6}$; (d) $-\frac{7}{2}$; (e) $-\frac{3}{2}$ 38. [9.3E] (a) -13.02 ; (b) -13.33 ; (c) -13.64 ; (d) -13.95 ; (e) -14.26 39. [9.3E] (a) 6.51; (b) 6.82; (c) 7.13; (d) 7.44; (e) 7.75 40. [9.3E] (a) $\frac{4}{9}$; (b) $\frac{5}{9}$; (c) $\frac{10}{9}$; (d) $\frac{14}{9}$; (e) $\frac{16}{9}$ 41. [9.3E] (a) $-\frac{5}{7}$; (b) $-\frac{11}{14}$; (c) $-\frac{10}{7}$; (d) $-\frac{15}{7}$; (e) $-\frac{20}{7}$ 42. [9.3F] (a) $-\frac{11}{2}$; (b) $-\frac{7}{3}$; (c) $-\frac{11}{4}$; (d) $-\frac{11}{5}$; (e) $-\frac{11}{6}$ 43. [9.3F] (a) $-\frac{7}{5}$; (b) $-\frac{7}{10}$; (c) $-\frac{7}{15}$; (d) $-\frac{7}{20}$; (e) $-\frac{7}{25}$ 44. [9.3F] (a) 10; (b) 15; (c) 20; (d) 25; (e) 30 45. [9.3F] (a) $-\frac{2}{3}$; (b) $-\frac{1}{2}$; (c) $-\frac{2}{5}$; (d) $-\frac{1}{3}$; (e) $-\frac{2}{7}$ 46. [9.3F] (a) -2 ; (b) -3 ; (c) -4 ; (d) -5 ; (e) -6 47. [9.3F] (a) $\frac{1}{2}$; (b) $\frac{1}{3}$; (c) $\frac{1}{4}$; (d) $\frac{1}{5}$; (e) $\frac{1}{6}$ 48. [9.3F] (a) -2 ; (b) -3 ; (c) -4 ; (d) -5 ; (e) -6 49. [9.3G] (a) (b) (c) (d) (e)

	3.7	$\sqrt{121}$	0.56	$-3\frac{1}{5}$	$\sqrt{21}$
Natural number					✓
Whole number					✓
Integer					✓
Rational number	✓	✓	✓	✓	
Irrational number					✓
Real number	✓	✓	✓	✓	✓

50. [9.4A] (a) -12 ; (b) -13 ; (c) -14 ; (d) -15 ; (e) -16 51. [9.4A] (a) -47 ; (b) -57 ; (c) -77 ; (d) -87 ; (e) -97 52. [9.4A] (a) -29 ; (b) -13 ; (c) -5 ; (d) -1 ; (e) 1 53. [9.4B] (a) -40 ; (b) -51 ; (c) -49 ; (d) -62 ; (e) -77

Cumulative Review Chapters 1-9

1. 10 2. 450 3. 692.31 4. $y = 8$ 5. $z = 39.6$ 6. $c = \frac{1}{4}$ 7. 0.23 8. 32 9. 50% 10. 75 11. \$162 12. Agriculture 13.

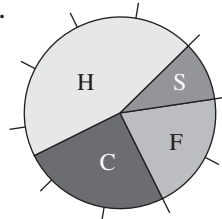

14. 4% 15. 2 degrees 16. 47% 17. 6 18. 17 19. 4 20. 324 in. 21. $1\frac{1}{3} \text{ ft}$ 22. $5\frac{2}{3} \text{ yd}$ 23. 72 in. 24. 1700 dm 25. 13.4 in.

26. 50.24 ft 27. 160 cm² 28. 113.04 cm² 29. 261 in.²
 30. 200 cm³ 31. 3052.08 in.³ 32. Obtuse 33. 125° 34. 70
 35. 10 36. $4\frac{3}{4}$ 37. 9.8 38. -9.8 39. $\frac{2}{35}$ 40. 4.3 41. $-\frac{11}{30}$
 42. $-\frac{1}{3}$ 43. $-\frac{9}{5}$ 44. 81

Chapter 10

Exercises 10.1

1. $2x$; -3 3. $-3x^2$; $0.5x$; -6 5. $\frac{1}{5}x$; $-\frac{3}{4}y$; $\frac{1}{8}z$ 7. $6x + 3y$
 9. $3a - 3b$ 11. $-10x + 5y$ 13. $24x^2 + 16$ 15. $-12x^2 + 18$
 17. $6x^2 + 9x + 15$ 19. $-15x^2 + 10x + 15$ 21. $0.5x + 0.5y - 1.0$
 23. $\frac{6}{5}a - \frac{6}{5}b + 6$ 25. $-2x + 2y - 8$ 27. $-0.3x - 0.3y + 1.8$
 29. $-\frac{5}{2}a + 5b - \frac{5}{2}c + \frac{5}{2}$ 31. $3(x + 5)$ 33. $9(y - 2)$ 35. $-5(y - 4)$
 37. $-3(x + 9)$ 39. $b(x - y + z)$ 41. $10a$ 43. $6x$ 45. $10a^2$ 47. $11x$
 49. $5y^2$ 51. $5x + 3y$ 53. $10x - 3y - 4$ 55. $2.4a - 3b - 7$
 57. $\frac{4}{7}a - \frac{4}{5}b$ 59. $\frac{1}{4}x - \frac{5}{11}b$ 61. $-6a - 13b$ 63. $a - 5b$
 65. $-3b^2 + 5a$ or $5a - 3b^2$ 67. $3a^2 - 2b$ 69. $-4b^2 + 8a$ or $8a - 4b^2$
 71. -2 73. -8 75. 135 77. 8 79. 32 81. 29.5, 31.2, 32.9,
 34.6, 36.3; Answers may vary 83. 32.82, 33.34, 33.86, 34.38, 34.9;
 Answers may vary 85. 716.2, 766.7, 817.2, 867.7, 918.2; Answers
 may vary 87. 380.8, 393.4, 406, 418.6, 431.2; Answers may vary
 89. 9.72 million; Answers may vary 91. 10.92 million 93. 17 million
 tons; very close 99. terms 101. trinomial 103. $-a + b$
 105. evaluated 107. (a) $3x + y$; (b) $-2x + 5y$ 109. (a) $4a$;
 (b) $4a + 6b$; (c) $\frac{5}{9}a + \frac{1}{7}b$ 111. (a) $3a + 6b$; (b) $10a - 15b$;
 (c) $-4a + 12b - 4c$ 113. $9 \cdot 25 \cdot 1 = 225$ 115. $1000 \cdot 1 \cdot 25 \cdot 8 =$
 200,000

Exercises 10.2

1. (a) $\frac{1}{16}$; (b) $\frac{1}{x^2}$ 3. (a) $\frac{1}{125}$; (b) $\frac{1}{y^3}$ 5. (a) $\frac{1}{81}$; (b) $\frac{1}{z^4}$ 7. (a) 2^{-3} ;
 (b) x^{-3} 9. (a) 4^{-5} ; (b) y^{-5} 11. (a) 3^{-5} ; (b) z^{-5} 13. (a) 243; (b) x^{13}
 15. (a) 4; (b) y^5 17. (a) $\frac{1}{16}$; (b) $\frac{1}{x^4}$ 19. (a) $\frac{1}{216}$; (b) $\frac{1}{y^3}$ 21. (a) $\frac{1}{64}$;
 (b) $\frac{1}{x^{10}}$ 23. x^2 25. y^2 27. $\frac{1}{a^2}$ 29. $\frac{1}{x^2}$ 31. $\frac{1}{x^2}$ 33. $\frac{1}{a^2}$ 35. $b^0 = 1$
 37. 243 39. $\frac{1}{64}$ 41. $\frac{1}{y^3}$ 43. x^3 45. $\frac{1}{x^2}$ 47. $\frac{1}{x^2}$ 49. x^3 51. 81
 53. $\frac{1}{9}$ 55. 64 57. $\frac{1}{9}$ 59. $\frac{1}{y^2}$ 61. $\frac{1}{y^2}$ 63. a^6 65. $\frac{x^6}{y^6}$ 67. $\frac{y^6}{x^6}$
 69. $\frac{1}{x^{12}y^6}$ 71. $\frac{1}{x^{12}y^6}$ 73. $x^{12}y^{12}$ 75. \$1259.71 77. \$1464.10
 79. $7.56 \times 10^9 = 7,560,000,000$ pounds 81. \$270,000,000 =
 \$270 million 83. \$39,000 85. (a) 123,454,321; (b) 12,345,654,321
 87. (a) $5^2 = 25$; (b) $7^2 = 49$ 93. 1 95. x^{m+n} 97. x^{m-n}
 99. $P(1 + r)^n$ 101. (a) 64; (b) $\frac{1}{x^6}$; (c) $\frac{1}{a^6}$; (d) b^{10} 103. (a) $\frac{a^{12}}{b^8}$; (b) $\frac{b^{12}}{a^{12}}$;
 (c) $\frac{a^6}{b^8}$ 105. (a) 6^{-3} ; (b) c^{-4} 107. 73.1 109. 73,100

Exercises 10.3

1. 6.8×10^7 3. 2.93×10^8 5. 1.9×10^9 7. 2.4×10^{-4}
 9. 2×10^{-9} 11. 235 13. 8,000,000 15. 6,800,000,000
 17. 0.23 19. 0.00025 21. 1.5×10^{10} 23. 3.06×10^4
 25. 1.24×10^{-4} 27. 2×10^3 29. 2.5×10^{-3} 31. (a) 4.8×10^{10} ;
 (b) 48,000,000,000 33. 4.63 35. 5 37. $9.66 \times 10^6 =$
 9,660,000 people 39. 1.8×10^4 people/km² = 18,000 people/km²
 41. $5 \times 10^2 = 500$ sec 43. 2.99792458×10^8
 45. 3.09×10^{13} 47. 3.27 51. left 53. 40 55. 2.5×10^5
 57. 4,500,000,000 59. $x = -3$ 61. $x = -\frac{1}{10}$ 63. $x = -0.5$
 65. $x = -3$

Exercises 10.4

1. $x = -2$ 3. $y = -\frac{1}{2}$ 5. $x = -7$ 7. $y = \frac{3}{10}$ 9. $x = 6.1$
 11. $x = -8$ 13. $y = \frac{1}{5}$ 15. $x = -2.3$ 17. $x = -16$
 19. $y = -12.4$ 21. $z = -2$ 23. $x = -\frac{1}{2}$ or -0.5 25. $y = \frac{4}{3}$ or $1\frac{1}{3}$

27. $x = 1.1$ 29. $y = 1.1$ 31. $x = \frac{10}{3}$ 33. $x = \frac{6}{5}$ 35. $x = 1$
 37. $y = 2$ 39. $y = -10$ 41. $x = \frac{12}{5}$ 43. $y = -\frac{10}{3}$ 45. $y = 1$
 47. $x = 1$ 49. $x = 0$ 51. $x = -\frac{20}{3}$ 53. $y = -\frac{16}{3}$ 55. $x = \frac{15}{2}$
 57. $y = \frac{1}{2}$ 59. $y = \frac{11}{6}$ 61. (a) $y = 0.025x$; (b) The Division Principle
 63. 2120 65. \$110 67. \$122 69. 70 in. 73. equation
 75. $a - c = b - c$ 77. $\frac{a}{c} = \frac{b}{c}$, $c \neq 0$ 79. $x = -1$ 81. $y = -7$
 83. $z = -3$ 85. $x = 5$ 87. $x = 4$ 89. $x = -9$ 91. $\frac{2000}{3}$ 93. 270

Exercises 10.5

Translate This

1. K 3. A 5. B 7. F 9. J

1. \$18 3. 10,207 5. 10,196 7. \$68 9. 10 11. 12 13. 27 gal
 15. 700 ft 17. \$36 19. 144 21. 8% 23. 8% 25. 21% 27. 4
 29. 9 31. 3 hr 33. 8000 gigs 35. 500 employees, 351 IT decision-
 makers 37. 175 SD, 155 LS, 133 IS 39. 800 teens, 573 tweens
 41. 104 teens, 69 tweens 43. (a) BMR = 12W; (b) 150 lb
 45. (a) 700 = 0.20C; (b) 3500 calories; (c) 1 lb 47. (a) $C = 920$ h;
 (b) 2760 calories; (c) the 150-lb person 49. (a) 170 lb; (b) 140 lb;
 (c) 119 lb 51. (a) $P = 0.067E$; (b) 10.05 lb; (c) 140 lb
 53. (a) 2170; (b) 2710; (c) 3070 55. (a) 3.3 lb; (b) 0.5 lb
 57. (a) 893 million L; (b) 3524 million L; (c) 6155 million L
 59. (a) 310.8 million; (b) 74 yr; (c) 2080 (2006 + 74) 61. +6 63. +8
 69. Read 71. Translate 73. Verify 75. 4 77. 320 mi 79. 180 lb

Review Exercises

1. [10.1A] (a) $6x^3$; $-3x^2$; $7x$; -7 ; (b) $5x^3$; $-4x^2$; $6x$; -6 ;
 (c) $4x^3$; $-5x^2$; $5x$; -5 ; (d) $3x^3$; $-6x^2$; $4x$; -4 ; (e) $2x^3$; $-7x^2$; $3x$; -3
 2. [10.1B] (a) $2x + 4y$; (b) $3x + 6y$; (c) $4x + 8y$; (d) $5x + 10y$;
 (e) $6x + 12y$ 3. [10.1B] (a) $-4x + 8y - 4z$; (b) $-5x + 10y - 5z$;
 (c) $-6x + 12y - 6z$; (d) $-7x + 14y - 7z$; (e) $-8x + 16y - 8z$
 4. [10.1C] (a) $3(x - 4y)$; (b) $3(x - 5y)$; (c) $3(x - 6y)$; (d) $3(x - 7y)$;
 (e) $3(x - 8y)$ 5. [10.1C] (a) $10(4x - 5y - 6z)$;
 (b) $10(3x - 4y - 5z)$; (c) $10(2x - 3y - 4z)$; (d) $10(x - 2y - 3z)$;
 (e) $10(x - y - 2z)$ 6. [10.1D] (a) $2x + 9y$; (b) $3x + 8y$;
 (c) $4x + 7y$; (d) $4x + 9y$; (e) $4x + 9y$ 7. [10.1D] (a) $-0.2x + 0.54y$;
 (b) $-0.3x + 0.55y$; (c) $-0.4x + 0.56y$; (d) $-0.5x + 0.57y$;
 (e) $-0.6x + 0.58y$ 8. [10.1D] (a) $\frac{4}{11}x + \frac{7}{13}y$; (b) $\frac{5}{11}x + \frac{6}{13}y$;
 (c) $\frac{6}{11}x + \frac{5}{13}y$; (d) $\frac{7}{11}x + \frac{4}{13}y$; (e) $\frac{8}{11}x + \frac{3}{13}y$
 9. [10.1E] (a) $3a + 3b$; (b) $4a + 3b$; (c) $5a + 7b$; (d) $8a + 3b$;
 (e) $7a + 8b$ 10. [10.2A] (a) $\frac{1}{4}$; (b) $\frac{1}{8}$; (c) $\frac{1}{16}$; (d) $\frac{1}{32}$; (e) $\frac{1}{64}$ 11. [10.2A]
 (a) 2^{-3} ; (b) 2^{-4} ; (c) 2^{-5} ; (d) 2^{-6} ; (e) 2^{-7} 12. [10.2B] (a) x^7 ;
 (b) x^8 ; (c) x^9 ; (d) x^{10} ; (e) x^{11} 13. [10.2B] (a) $\frac{1}{4}$; (b) $\frac{1}{8}$; (c) $\frac{1}{16}$; (d) $\frac{1}{32}$;
 (e) $\frac{1}{64}$ 14. [10.2B] (a) $\frac{1}{y^2}$; (b) $\frac{1}{y^3}$; (c) $\frac{1}{y^4}$; (d) $\frac{1}{y^5}$; (e) $\frac{1}{y^6}$ 15. [10.2C] (a) 64;
 (b) 128; (c) 256; (d) 512; (e) 1024 16. [10.2C] (a) $\frac{1}{x^3}$; (b) $\frac{1}{x^4}$; (c) $\frac{1}{x^5}$;
 (d) $\frac{1}{x^6}$; (e) $\frac{1}{x^7}$ 17. [10.2C] (a) y^2 ; (b) y^3 ; (c) y^4 ; (d) y^5 ; (e) y^6 18. [10.2D]
 (a) 4; (b) 16; (c) 64; (d) 256; (e) 1024 19. [10.2D] (a) $\frac{1}{y^8}$; (b) $\frac{1}{y^{12}}$; (c) $\frac{1}{y^{16}}$;
 (d) $\frac{1}{y^{20}}$; (e) $\frac{1}{y^{24}}$ 20. [10.2D] (a) z^6 ; (b) z^9 ; (c) z^{12} ; (d) z^{15} ; (e) z^{18}
 21. [10.2D] (a) $\frac{x^6}{y^6}$; (b) $\frac{x^9}{y^9}$; (c) $\frac{x^{12}}{y^{12}}$; (d) $\frac{x^{15}}{y^{15}}$; (e) $\frac{x^{18}}{y^{18}}$ 22. [10.2D] (a) $\frac{x^4}{y^4}$;
 (b) $\frac{x^6}{y^6}$; (c) $\frac{x^8}{y^8}$; (d) $\frac{x^{10}}{y^{10}}$; (e) $\frac{x^{12}}{y^{12}}$ 23. [10.3A] (a) 4.4×10^7 ; (b) 4.5×10^8 ;
 (c) 4.6×10^6 ; (d) 4.7×10^4 ; (e) 4.8×10^7 24. [10.3A] (a) 1.4×10^{-3} ;
 (b) 1.5×10^{-4} ; (c) 1.6×10^{-5} ; (d) 1.7×10^{-6} ; (e) 1.8×10^{-7}
 25. [10.3A] (a) 7830; (b) 68,300; (c) 583,000; (d) 4,830,000;
 (e) 38,300,000 26. [10.3A] (a) 0.084; (b) 0.0074; (c) 0.00064;
 (d) 0.000054; (e) 0.0000044 27. [10.3B] (a) 2.2×10^5 ; (b) 9.3×10^6 ;
 (c) 1.24×10^8 ; (d) 1.55×10^9 ; (e) 1.86×10^9

28. [10.3B] (a) 2.2×10^{-2} ; (b) 3.3×10^{-1} ; (c) 4.4×10^{-3} ; (d) 5.5×10^{-4} ; (e) 6.6×10^{-4} 29. [10.3B] (a) 5×10^0 or 5; (b) 6×10^1 ; (c) 7×10^1 ; (d) 8×10^{-1} ; (e) 9×10^0 or 9 30. [10.4A] (a) $y = \frac{1}{6}$; (b) $y = \frac{1}{4}$; (c) $y = \frac{3}{10}$; (d) $y = \frac{1}{3}$; (e) $y = \frac{5}{14}$ 31. [10.4A] (a) $y = -6$; (b) $y = -9$; (c) $y = -12$; (d) $y = -15$; (e) $y = -18$ 32. [10.4A] (a) $z = -2$; (b) $z = -3$; (c) $z = -4$; (d) $z = -6$; (e) $z = -7$ 33. [10.4B] (a) $x = -\frac{5}{3}$; (b) $x = -\frac{8}{3}$; (c) $x = -\frac{10}{3}$; (d) $x = -\frac{13}{3}$; (e) $x = -\frac{16}{3}$
34. [10.4B] (a) $x = 8$; (b) $x = 9$; (c) $x = 10$; (d) $x = 11$; (e) $x = 12$
35. [10.4B] (a) $x = 2.1$; (b) $x = 2.1$; (c) $x = 2.1$; (d) $x = 2.1$; (e) $x = 2.1$ 36. [10.4B] (a) $x = 11$; (b) $x = 8$; (c) $x = 7$; (d) $x = 6$; (e) $x = 5$ 37. [10.4B] (a) $x = -\frac{21}{2}$; (b) $x = -\frac{35}{2}$; (c) $x = -\frac{49}{2}$; (d) $x = -\frac{63}{2}$; (e) $x = -\frac{77}{2}$ 38. [10.4B] (a) $x = -\frac{5}{2}$; (b) $x = -\frac{5}{2}$; (c) $x = -\frac{5}{2}$; (d) $x = -\frac{5}{2}$; (e) $x = -\frac{5}{2}$ 39. [10.5A] (a) $m = 202$; (b) $m = 203$; (c) $m = 204$; (d) $m = 206$; (e) $m = 207$
40. [10.5A] (a) 6%; (b) 8%; (c) 10%; (d) 12%; (e) 14%

Cumulative Review Chapters 1–10

1. 52 2. 615.38 3. 0.23 4. 36 5. 50% 6. 20 7. \$112.50
 8. 1% 9. 40% 10. 5 11. 13 12. 10 13. 144 in. 14. $1\frac{5}{12}$ ft
 15. $5\frac{2}{3}$ yd 16. 84 in. 17. 2400 dm 18. 15.2 cm 19. 56.52 in.
 20. 80 cm^2 21. 28.26 cm^2 22. 105 cm^3 23. 7234.56 in.^3
 24. Right 25. 120° 26. 90 27. 15 28. $3\frac{4}{5}$ 29. 3.5 30. -11.5
 31. $\frac{11}{40}$ 32. 0.3 33. $-\frac{24}{35}$ 34. $-\frac{9}{8}$ 35. $-\frac{10}{3}$ 36. 49 37. $20x - 40y$
 38. $10(6x - 3y - 4z)$ 39. $-5x + 3y$ 40. $\frac{1}{9^2} = \frac{1}{81}$ 41. $\frac{1}{x^7}$ 42. $\frac{9x^6}{y^4}$
 43. 2.4×10^{-8} 44. 28,200,000 45. 3.5×10^{-8} 46. $x = -49$
 47. $x = 2$ 48. $x = 7$ 49. $x = 13$

Chapter 1

Opener: © Anne Gransden/SuperStock; **p. 5:** © AP Photo/Gail Oskin; **p. 6:** © Brand X Pictures/Creatas/Corbis RF; **p. 13:** © The McGraw-Hill Companies, Inc./Emily and David Tietz, photographer; **p. 19:** © The McGraw-Hill Companies, Inc./Connie Mueller, photographer; **p. 23:** © Reuters/Corbis; **p. 33(left):** Courtesy NPS/Canyon de Chelly National Monument; **p. 33(right):** © Getty RF; **p. 50:** © Todd Pearson/The Image Bank/Getty; **p. 57:** © Photolink/Getty RF; **p. 58:** Courtesy of The Florida Strawberry Festival ®; **p. 63, p. 91:** © The McGraw-Hill Companies, Inc./Emily and David Tietz, photographer; **p. 100:** Courtesy of Ignacio Bello.

Chapter 2

Opener: © Edward Cohen/SuperStock; **p. 114, p. 118, p. 120:** © The McGraw-Hill Companies, Inc./Emily and David Tietz, photographer; **p. 123, p. 125, p. 134, p. 141:** Courtesy of Ignacio Bello; **p. 142(top):** NASA; **p. 142(bottom):** © greenwales/Alamy; **p. 144:** © Vol. 51/Getty RF; **p. 145(top, left):** © Getty RF; **p. 145(top, right):** © Comstock/PunchStock RF; **p. 145(bottom, left):** © allOver photography/Alamy; **p. 145(bottom, right):** © Patrick Lynch/Alamy; **p. 154(left, right):** © Image Source/Getty RF; **p. 155(top):** Courtesy USDA ARS; **p. 155(bottom):** © Getty RF; **p. 157(all):** © The McGraw-Hill Companies, Inc./Emily and David Tietz, photographer; **p. 166:** Illinois EPA; **p. 177:** Courtesy of Ignacio Bello; **p. 181:** AP Photo/Shizuo Kambayashi; **p. 192:** © The McGraw-Hill Companies, Inc./Emily and David Tietz, photographer.

Chapter 3

Opener: © Robert Brenner/PhotoEdit; **p. 210:** Courtesy Jim Goetz; **p. 216, p. 220(both), p. 221(all), p. 224, p. 234(both):** Courtesy of Ignacio Bello; **p. 251:** © Getty RF.

Chapter 4

Opener: © Susan VanEtten/PhotoEdit; **p. 268(left):** © Underwood & Underwood/Corbis; **p. 268(right):** © PhotoLink/Getty RF; **p. 270:** © The McGraw Hill Companies, Inc./Connie Mueller Photographer; **p. 270:** © Corbis RF; **p. 282:** © Gary Meisner Goldennumber.net; **p. 284:** © Tom Pantages adaptation/Courtesy BLM; **p. 285:** © Corbis/Sygma; **p. 290:** © Gary Meisner Goldennumber.net; **p. 293:** © Brand X Pictures/Getty RF; **p. 295, p. 296:** © Nick Hanna.

Chapter 5

Opener: © Alan Schein Photography/Corbis; **p. 311:** Courtesy of Ignacio Bello; **p. 334(top):** © Getty RF; **p. 334(bottom):** © The McGraw-Hill Companies, Inc./John Flournoy, photographer; **p. 337:** © Brand X Pictures RF; **p. 341:** © Ingram Publishing/AGE Fotostock RF; **p. 346:** Courtesy Honda; **p. 351:** © Ingram Publishing/SuperStock RF.

Chapter 6

Opener: Courtesy National Library; **p. 375(woman):** © Vol. 114/Getty RF; **p. 375(man):** © Vol. 23/PhotoLink/Getty RF; **p. 375(nurse):** © SS38/Getty RF; **p. 395:** Courtesy of Ignacio Bello; **p. 401:** © Diane Nelson; **p. 408(both), p. 411(both):** Courtesy of Ignacio Bello.

Chapter 7

Page 432: © Photodisc/Getty RF; **p. 437(left):** © Flat Earth Images RF; **p. 437(right), p. 439:** © Photodisc/Getty RF; **p. 450:** © Chromosohm Media Inc./The Image Works; **p. 454:** Courtesy Michel Verdure/Royal Caribbean International; **p. 455:** © The McGraw-Hill Companies, Inc./Emily and David Tietz, photographer; **p. 459:** © Zuma/Newscom; **p. 468:** © Creatas/PunchStock RF.

Chapter 8

Opener: © David Young-Wolff/PhotoEdit; **p. 480:** Digital Image: © The Museum of Modern Art/Licensed by SCALA/Art Resource, NY; **p. 480:** © The Museum of Modern Art/Licensed by SCALA/Art Resource, NY; **p. 482:** © Michael T. Sedam/Corbis; **p. 486, p. 493(all):** © David Young-Wolff/PhotoEdit; **p. 493(rock carving):** © Michael T. Sedam/Corbis; **p. 506:** © Getty RF; **p. 510(left):** Courtesy of Fermi National Accelerator Lab/U.S. Department of Energy; **p. 510(right):** © San Francisco Chronicle Corbis SABA; **p. 511:** © Nathan Kirkman Photography; **p. 516(both), p. 518(both):** Courtesy of Ignacio Bello; **p. 519(both):** Viz-A-Ball is a registered trademark of Brunswick Bowling & Billiards Corporation. U.S. Patent No. 6,524,419 and 6,691,759; **p. 519(bottom):** Stockbyte/Getty RF; **p. 520(top):** Courtesy of Elope Inc.; **p. 520(bottom):** © Corbis RF; **p. 521:** Courtesy of EPA; **p. 522:** © Photodisc/Getty RF; **p. 522(middle, left), p. 522(middle, right):** © Comstock/Alamy RF; **p. 522(bottom, left):** © Bill Aron/PhotoEdit; **p. 522(bottom, right):** © Corbis RF; **p. 523(cylinders):** Courtesy of UltraTech International; **p. 523(sugar):** Courtesy of Ignacio Bello; **p. 523(ornament):** © Vol. 56/Getty RF; **p. 524(top, left):** Courtesy of Ignacio Bello; **p. 524(top, right):** © Dynamic Graphics Group/PunchStock RF; **p. 524(bottom, left):** © PhotoDisc/Getty RF; **p. 524(bottom, left):** © Digital Vision/Getty RF; **p. 524(bottom, right):** © Corbis RF; **p. 525(bench), p. 525(UPS box):** Courtesy of Ignacio Bello; **p. 525(tornado):** © Vol. 188/Corbis RF; **p. 526(top):** © Michael Newman/PhotoEdit; **p. 526(bottom):** Courtesy of Ignacio Bello; **p. 527:** © David Young-Wolff/PhotoEdit; **p. 530:** © Vol. 51/Getty RF; **p. 531:** © Aerial Archives/Alamy; **p. 533(stadium):** © Larry W. Smith/epa/Corbis; **p. 533(all):** Courtesy of Ignacio Bello; **p. 534:** Courtesy HNB.T.

Chapter 9

Opener: © Robert George Young/Masterfile; **p. 561:** © Image 100/Corbis RF; **p. 575:** © David Young-Wolff/PhotoEdit; **p. 587:** © Vol. 27/PhotoLink/Getty RF.

Chapter 10

Opener: © Neal & Molly Jansen/Superstock; **p. 628:** Courtesy of Ignacio Bello; **p. 634:** © Science Source/Photo Researchers; **p. 644:** Courtesy of Nasa/James B. Irwin; **p. 651, p. 652(top):** © PhotoDisc/Getty RF; **p. 652(bottom):** © Flat Earth Images RF; **p. 653(both):** © Corbis RF; **p. 654(left), p. 654(right):** © JPL/NASA; **p. 655:** © PhotoDisc/Getty RF.

This page intentionally left blank

A

absolute value, 554–555, 576, 596
 acre (unit), 452
 acute angle, 485, 537
 acute triangle, 488, 538
 Adams, John A., 78
 addends, 104
 addition
 in algebra, 30
 associative property of, 616
 commutative property of, 24, 616
 of decimals, 212–214
 of fractions, 157–161, 199
 identity for, 24, 104
 of integers, 555–557, 596
 of mixed numbers, 168–171
 multiplication as, 134
 in order of operations, 84
 of rational numbers, 577
 of whole numbers, 23–29
 addition principle, 93, 105, 634
 additive inverses, 554, 560, 576, 596
 algebra
 addition and, 30
 on calculators, 30
 decimals and, 217
 distributive property and, 609
 division and, 70
 and fractions, 130
 letters in, 7
 multiplication in, 58, 63
 order of operations and, 87
 origin of, 607
 solving equations, 634–640
 subtraction and, 45
 word problems and, 644–648
 al-Khowarismi, Abu Ja'far
 Muhammad ibn Musa, 607
 angle(s)
 acute, 485, 537
 classification of, 485
 complementary, 486, 538
 definition of, 482, 537
 measurement of, 484
 naming of, 482, 484
 obtuse, 485, 537
 right, 484, 485, 537
 sides of, 537
 straight, 484, 537
 sum of, in triangle,
 489–490, 538
 supplementary, 487, 538
 of triangles, 488
 types of, 485
 vertex of, 537
 annual percentage rate, 352, 363
 area
 on calculators, 511
 of circles, 509–510, 539
 conversion between U.S. and
 metric units, 452
 of irregular figures, 517–518
 metric units of, 450–451

of parallelogram, 508, 539
 of rectangles, 57–58, 104, 141,
 506–507, 538
 of squares, 506–507, 538
 of trapezoid, 509, 539
 of triangles, 507–508, 538
 U.S. units of, 451–452
 associative property, 57, 104, 616
 Australian aborigines, 1
 averages, 70, 181. *See also* mean;
 median
 axis, on bar graphs, 381

B

Babylonians, 1
 bar graphs, 420
 axis on, 381
 drawing, 381–382
 horizontal, 382
 reading, 380–381
 base
 of exponent, 77, 105
 of percentage, 316, 319–320,
 328–330, 362
 Bramagupta, 549
 Bushmen, of South Africa, 1

C

calculators
 additive inverse on, 560
 algebra on, 30
 area on, 511
 decimals on, 217, 229, 240, 248
 division on, 68
 exponents on, 625
 fractions on, 130, 142, 240, 248
 integers on, 560, 571
 mean on, 413
 multiplication on, 58
 numerals and, 7
 order of operations on, 87
 parentheses on, 592
 percents on, 311, 323, 338
 power key on, 338
 prime numbers on, 79
 recall key on, 338
 scientific notation on, 631
 stat button on, 413
 subtraction on, 45
 temperature conversion on, 466
Canon Mathematics (Vieta), 209
 Cardan, Girolamo, 549
 carrying over, in addition, 26
 Celsius scale, 465, 472
 centigram, 471
 centiliter, 471
 centimeter, 464
 conversion from feet, 445, 446
 conversion from meters, 441, 451
 conversion to inches, 445, 471
 conversion to meters, 441
 definition of, 470
 square, 451

Chiarino, Giorgio, 305
 China, negative numbers in, 549
 circle graphs, 420
 drawing, 398–400
 reading, 396–398
 circles, 501, 509–510, 539
 circumference, 269, 298, 501, 538
 comma, decimal, 209
 commission, 337, 363
 commutative property
 of addition, 24, 104, 616
 of multiplication, 51, 104, 616
 comparing decimals, 244–245
 comparing fractions, 152–153
 comparing fractions with decimals,
 245–246
 complementary angle, 486, 538
 composite numbers, 73, 105
Composition in Red, Blue, and Yellow
 (Mondrian), 480
 compound interest, 335–336, 363,
 624, 659
 cones, volume of, 519–520, 539
 consumer credit
 annual percentage rate, 352, 363
 credit cards, 351–354
 mortgage, 356–357, 363
 Stafford loan program, 355, 363
 student loans, 355–356
 counting numbers, 2, 3, 103
 CRAM procedure, for solving
 equations, 640
 cross-product rule, 284
 cup (unit), conversion to milliliter,
 456, 471
 cylinders, volume of, 518, 539

D

Darwin, Charles, 371
 decigrams, 464, 471
 deciliter, 471
 decimal comma, 209
 decimal places, 210–211
 decimal point, 210
 decimals
 addition of, 212–214
 and algebra, 217
 on calculators, 217, 229, 240, 248
 comparing, 244–245
 converting percent from, 307–308
 converting percent to, 306–307
 division of, 224–226, 227–228, 259
 in equations, 251–252
 evolution of, 209
 expanded form of, 211–212, 259
 as fractions, 234–238
 multiplication of, 221–224, 259
 notation of, 209, 210–211
 and order of operations, 247–248
 repeating, 235, 236–237, 260
 rounding of, 226–227, 259
 subtraction of, 214–215
 terminating, 235, 236–237, 260

Index

- decimals (*continued*)
word names for, 210–211, 259
in word problems, 252–255
- decimeter, 470
- decrease, percent, 343–344, 362
- degrees, and angles, 484, 537
- dekagon, 498
- dekagrams, 464, 471
- dekameter, 439
conversion from meters, 440
conversion to meters, 440
definition of, 470
- dekiliter, 471
- denominator, 114, 149–152
- De Stijl art movement, 480
- diagramming fractions, 115
- diameter, 269, 298, 501
- dictionary, of mathematical words, 648
- difference, definition of, 38, 104
- digits, 2, 103
- discount, 363
- distributive property, 658
and algebra, 609
for factoring, 617
and multiplication, 52, 104, 617
- dividend, 63, 105
- division
and algebra, 68
of decimals, 224–226, 227–228, 259
definition of, 64
of exponents, 622
of fractions, 138–140
of integers, 566–568, 596
long, 65–66
lowest common denominator
and, 150
with mixed numbers, 140
as multiplication, 63
and one, 64, 105
in order of operations, 84
of rational numbers, 579–580
with scientific notation, 629–630
and zero, 64, 105, 568
- division principle, 94, 105, 634
- divisor, 63, 105
- E**
- Egyptians, 1
- Einstein, Albert, 634
- Einstein's problem, 592
- Elements* (Euclid), 479
- ellipsis, 3
- equations
decimals in, 251–252
definition of, 105
equivalence of, 92, 199, 260
proportions as, 282–285
solving, 91–94, 186–187, 634–640
translating, 186
- equilateral triangle, 488, 538
- equivalence
of equations, 92, 199, 260
of fractions, 125, 199
- Eratosthenes, 73
- estimation
addition and, 25
subtraction and, 38–39
- Euclid, 479
- evaluation, of expressions, 612–613
- expanded form
of addition, 25
of decimals, 3–4, 103, 211–212, 259
of subtraction, 39
- exponential notation, 77
- exponents
on calculators, 625
definition of, 105
division of, 622
as exponents, 623, 658
and fractions, 137–138
integers and, 568–569, 619–620, 658
multiplication of, 621
negative, 620
in order of operations, 84, 591
product rule of, 621
products involving, 78
and scientific notation, 628–630
zero as, 620
- expressions
definition of, 608, 658
evaluating, 612–613
factoring of, 609–610
simplification of, 610–612
- F**
- factorization, 72
- factors
definition of, 51, 104
distributive property and, 617
greatest common, 128
primes and, 72, 73–74, 105
- factor trees, 74
- Fahrenheit scale, 465, 472
- Fibonacci, Leonardo, 267
- Fibonacci sequence, 267, 298
- figures, naming of, 483–484
- foot (unit), 433
conversion to centimeters, 445, 446
conversion to inches, 434
conversion to miles, 434
conversion to yards, 434
definition of, 470
square, 451, 452
- fraction(s). *See also* rational numbers
addition of, 157–161, 199
and algebra, 130
in ancient Egypt, 113
on calculator, 130, 142, 240, 248
and circle graphs, 398–400
comparing, 152–153
converting percents from, 309–310
converting percents to, 308–309
as decimals, 234–238
diagramming, 115
division of, 138–140
equivalent, 125–126, 199
- evolution of, 113
- exponents and, 137–138
- fundamental property of, 126
- graphs and, 163
- greatest common factor and, 128
- improper, 115
- least common multiple and,
147–153, 199
- lowest common denominator
and, 149–152, 158–159, 199
- multiplication of, 135–136, 199
- notation of, 114
- one as, 116
- proper, 115
- ratios as, 268–271
- reciprocals of, 138, 199
- reducing, 127–128
- subtraction of, 161–163, 199
- unit, 433, 470
- zero as, 116
- France, negative numbers in, 549
- fundamental property of
fractions, 126
- G**
- gallons, 456
- Gauss, Carl Friedrich, 371
- geometry
history of, 479
notation of, 480–481, 482
- gram
conversion from milligrams, 464
definition of, 464
- graphs
bar, 382, 420
circle, 398–400, 420
and fractions, 163
line, 382–383, 420
- Graunt, John, 371
- greater than (>), 553
- greatest common factor, 128, 609–610
- Greeks, early, 1
- grouping symbols
multiple, 85, 178
in order of operations, 84,
177–180, 591
- H**
- hectare, 452
- hectogram, 471
- hectoliter, 471
- hectometer, definition of, 439, 470
- heptagon, 498
- hexagon, 498
- hieroglyphics, 113
- horizontal bar graphs, 382
- hypotenuse, length of, 529
- I**
- identity
for addition, 24, 104
for multiplication, 51, 104
- improper fractions, 115

inch (unit), 432–433
 conversion from centimeters, 445, 455
 conversion from yards, 433
 conversion to centimeters, 471
 conversion to feet, 434
 definition of, 470
 square, 451

increase, percent, 343–344, 362

India, negative numbers in, 549

inequalities, 104, 553

integers, 551, 596
 addition of, 555–557, 596
 on calculators, 560, 571
 division of, 566–568, 596
 exponents and, 568–569, 619–620, 658
 multiplication of, 566–568, 569–570, 596
 and parentheses, 567
 subtraction of, 558–559, 596

interest
 compound, 335–336, 363, 624, 659
 simple, 334–335, 363

intersecting lines, 481, 536

irrational numbers, 549, 582, 596

isosceles triangle, 488, 538

Italy, negative numbers in, 549

J

Jefferson, Thomas, 431

K

kilogram
 conversion to pounds, 465
 definition of, 471

kiloliter, 471

kilometer, 439
 conversion from miles, 446, 455
 conversion to meters, 439
 conversion to miles, 446, 451, 471
 definition of, 470

L

Laplace, Pierre-Simon, 371

least common multiple, 147–153, 199
 definition of, 147
 of two numbers, 148

length
 foot as unit of, 433
 inch as unit of, 432–433
 metric, 439–441, 471
 mile as unit of, 433
 U.S. measurements, 432–435, 471
 yard as unit of, 433

less than (<), 553

Liber Abaci (Book of Calculations)
 (Fibonacci), 267

linear equations, solving,
 634–640, 659

line graphs, 420
 drawing, 383–384
 reading, 382–383

line(s)
 definition of, 481, 536
 intersecting, 481, 536
 notation of, 481
 parallel, 481, 483, 536
 perpendicular, 483, 537

line segment, 481, 483, 536

liter
 conversion from milliliter, 456
 definition of, 471

long division, 65–66

lowest common denominator, 149–152,
 158–159, 199

lowest terms, of fraction, 127–128

M

mass. *See* weight

mean. *See also* averages
 on calculators, 413
 definition of, 408, 421
 finding, 408–409
 uses of, 412
 weighted, 409, 421

measurement
 history of, 431
 metric area, 450–451
 metric length, 439–441
 U.S. area, 451–452
 U.S. length, 432–435
 U.S. volume, 455–456
 U.S. weight, 462–465

median
 definition of, 410, 421
 finding, 410–411
 uses of, 412

Mendel, Gregor, 371

meter, 439, 471
 conversion from centimeters, 441
 conversion from dekameters, 440
 conversion from kilometers, 439
 conversion from yards, 446, 447
 conversion to centimeter, 441, 451
 conversion to dekameters, 440
 conversion to yards, 446, 447, 471
 definition of, 470
 square, 451

metric system
 conversion to use of, 471
 converting units of area, 450–451
 converting units of length, 439–441
 converting units of temperature,
 465–466
 converting units of weight, 464–465
 history of, 431

mile (unit), 433
 conversion from feet, 434
 conversion from kilometers, 446,
 447, 451
 conversion to kilometers, 447, 466

milligram, 471
 conversion to grams, 464

milliliter, 471
 conversion from cup, 456

conversion from fluid ounce, 456
 conversion from tablespoon, 456
 conversion from teaspoon, 456
 conversion liter, 456

millimeter, 439
 definition of, 470

minuend, definition of, 38, 104

mixed numbers
 addition of, 168–170, 171–172
 definition of, 199
 division with, 140
 multiplication of, 136–137
 overview of, 116
 subtraction of, 659

mode
 definition of, 411, 421
 finding, 411–412
 uses of, 412

Mondrian, Pieter, 480

mortgage, 356–357, 363

Mouton, Gabriel, 431

multiple, least common, 147–153

multiples of ten, multiplying by,
 55–56

multiplicand, 104

multiplication
 as addition, 134
 in algebra, 58, 63
 associative property of, 57, 616
 commutative property of, 51, 104,
 616
 of decimals, 221–224, 259
 distributive property and, 52, 104,
 609, 617
 division as, 63
 of exponential expressions, 621
 and fraction equivalence, 125
 of fractions, 135–136, 199
 identity for, 51, 104
 of integers, 566–568, 569–570, 596
 by one, 51
 in order of operations, 84
 of rational numbers, 578
 with scientific notation, 629–630
 of whole numbers, 50–55
 by zero, 51

multiplication principle, 634

multiplication property, of zero, 104,
 566–568

multiplicative property of -1 , 617

multiplier, 104

N

Napier, John, 209

*Natural and Political Observations
 upon the Bills of Morality*
 (Graunt), 371

natural numbers, 3

negative integers, 551

negative numbers. *See also* integers
 history of, 549
 and integers, 551

nonagon, 498

Index

- notation
of decimals, 209, 210–211
exponential, 77
of fractions, 114
geometric, 480–481
of proportions, 282
of ratios, 268
number line, 551, 553
numbers
absolute value of, 554–555
addition of, 23–29
integers, 555–557, 596
rational, 577
additive inverses of, 554, 576
comparing, 554
composite, 73, 105
counting, 2, 3, 103
determining proportionality of, 284
division of, 63–65
integers, 566–568, 596
rational, 579–580
integers, 551
irrational, 549, 582, 596
mixed, 116, 136–137,
168–170, 199
multiplication of, 50–55
integers, 566–568, 569–570, 596
rational, 578
natural, 3, 103
negative, history of, 549
ordering of, 13–15
origin of, 1
and place value, 2–3
prime, 72, 105
rational, 596
absolute value of, 576
addition of, 577
additive inverses of, 576
definition of, 575
division of, 579–580
history of, 549
multiplication, 578
reciprocals of, 579–580
subtraction of, 577–578
real, 579–580
rounding, 15–17
signed, 551
subtraction of, 37–43
integers, 558–559, 596
rational, 577–578
vs. numeral, 2
whole, 2, 103
addition of, 23–29
multiplication of, 50–55
ordering of, 13–15
subtraction of, 37–43
numerals
expanded form, 3–4, 103
standard form of, 4–5
vs. numbers, 2
to words, 5–6
words to, 6–7
numerator, 114
- O**
obtuse angle, 485, 537
obtuse triangle, 488, 538
octagon, 498
one
division properties, 64, 105
as exponent, 105
as fraction, 116
as identity for multiplication, 51
negative, 617
ordering, of whole numbers, 13–15
order of operations, 83–84, 105,
177–180, 247–248,
588–590, 596
ounces
fluid, 455–456, 457, 471
solid
conversion from pounds, 463
conversion to pounds, 463
- P**
parallel lines, 481, 483, 536
parallelogram
area of, 508, 538
definition of, 499
parentheses ()
and addition of integers, 567
on calculators, 592
in order of operations, 84
removal of, 610–612, 658
parentheses [], in order of operations,
587
PEMDAS, 84, 105, 200, 588–590, 596
pentagon, 498
percent
and base, 316, 319–320, 328–330,
362
on calculators, 311, 323
commission, 337
converting from decimals, 307–308
converting from fractions, 309–310
converting to decimals, 306–307
converting to fractions, 308–309
definition of, 306, 362
discount, 337
finding, 316–319
history of, 306
increase and decrease, 343–344, 362
and proportions, 328–330, 362
sales tax, 333
total cost, 334
vs. percentage, 316, 362
percentage, vs. percent, 316, 362
perfect squares, 528
perimeter
definition of, 172, 199, 498, 538
of polygons, 29, 104, 498, 499
of rectangles, 499–500, 538
of squares, 499–500
of triangles, 29
perpendicular, 483, 537. *See also*
right angle
- pi, 501
pictographs, 374, 420
pie charts, reading, 396–400, 420
placeholders, 608, 658
place value, 2–3
and decimals, 211
and rounding, 15
and subtraction, 38–40
plane (geometric), 482
point (geometric), 480, 482, 536
polygons
definition of, 29
perimeter of, 29–30, 104, 498, 499
regular, 498
types of, 498–499
positive integers, 551
pound
conversion from kilograms, 465
conversion from ounces, 463
conversion from tons, 463
conversion to kilograms, 465
conversion to ounces, 463
conversion to tons, 464
power key, on calculator, 338
power rule of exponents, 623
prime factors, 73–74, 105
prime numbers
on calculator, 79
composite numbers and, 73
definition of, 72, 105
and lowest common denominator,
150
product rule of exponents, 621, 658
product(s)
definition of, 50, 104
involving exponents, 78
of two fractions, 135
proper fractions, 115
proportions
definition of, 282, 298
determining, 283–284
as equations, 282–285
notation of, 282
and percent, 328–330, 362
solving, 284–285
in word problems, 290–292
protractor, 408, 484
pyramids, volume of, 520–521, 539
Pythagoreans, 549
Pythagorean theorem, 527, 538
- Q**
quadrilateral, 498
quarts, 455–456, 471
quotient, 105
quotient rule of exponents, 622, 658
- R**
radius, 501
rates
definition of, 274
unit, 276–278, 298
writing, 274–276

ratio, 119
 definition of, 298
 as fractions, 268–271
 notation of, 268

rational numbers, 596. *See also* fraction(s)
 and absolute value, 576
 addition of, 577
 additive inverses of, 576
 definition of, 575
 division of, 579–580
 history of, 549
 reciprocals of, 579–580
 subtraction of, 577–578

ray (geometric), 481, 483, 537

real numbers, 579–580

recall key, on calculator, 338

reciprocals
 of fractions, 138, 199
 of rational numbers, 579–580, 596

rectangles
 area of, 58, 104, 141, 506–507, 538
 definition of, 499
 perimeter of, 499–500, 538

rectangular solids, volume of, 517–518, 539

reducing fractions, 127–128

regular polygons, 498

repeating decimals, 235, 236–237, 260

repetend, 235

rhombus, 499

right angle, 537. *See also* perpendicular
 definition of, 485
 and Pythagorean theorem, 529

right triangle, 488, 529, 538

rotation, of angles, 485

rounding
 of decimals, 226–227, 259
 of whole numbers, 15–17, 104

RSTUV method, 95, 105, 298, 644–648, 659

S

sales tax, 333

scalene triangle, 488, 538

scientific notation, 628–630, 659

sieve of Eratosthenes, 74

signed numbers, 551

simple interest, 334–335, 363

solution
 of equation, 91–92, 105, 186–187
 of proportions, 284–285

South American Indians, 1

spheres, volume of, 519, 539

square
 area of, 506–507, 538
 definition of, 499
 perimeter of, 499–500

square centimeters, 451

square inch, 451

square meters, 451

square roots, 528, 538

square yards, 452

Stafford loan program, 355, 363

standard form, of numerals, 5

stat button, on calculator, 413

statistics. *See also* averages; graphs;
 mean; median
 history of, 371

Stevin, Simon, 209

store key, on calculator, 338

story problems, 95

straight angle, 485, 537

subtraction
 of decimals, 214–215
 of fractions, 161–163, 199
 of integers, 558–559, 596
 of mixed numbers, 170–171
 in order of operations, 84
 of rational numbers, 577–578
 of whole numbers, 37–43

subtraction principle, 93–94, 105, 634

subtrahend, definition of, 38, 104

supplementary angle, 487, 538

surface, and area, 57

T

tables, 372–373

tablespoon, 457, 471

teaspoon, 457, 471

temperature, conversion between metric
 and U.S. scales, 465–466

ten, multiplying by multiples of, 55–56, 104, 223–224

terminating decimals, 235, 236–237, 260

terms
 combining like, 610
 definition of, 608

Thiende, The (The Tenth) (Stevin), 209

ton
 conversion from pounds, 464
 conversion to pounds, 463
 definition of, 471

translation, of equations, 186

trapezoid
 area of, 509, 538
 definition of, 499

triangle
 acute, 488, 538
 angles of, 488
 area of, 507–508, 538
 equilateral, 488, 538
 hypotenuse of, 529
 isosceles, 488, 538
 obtuse, 488, 538
 perimeter of, 29, 105
 and Pythagorean theorem, 529, 538
 right, 488, 529, 538
 scalene, 488, 538
 sides of, 489
 sum of angles in, 489–490, 538
 types of, 489

U

unit fractions, 433, 471

unit rates, 276–278, 298

unknowns, 608, 658

V

value, place, 2–3

variables, 608, 658

vertex, of angle, 482, 485, 537

Viete, Francois, 209

volume
 of cones, 519–520, 539
 conversion of metric to metric,
 456–457
 conversion of U.S. to metric units,
 456–457
 of cylinders, 518, 539
 of pyramids, 520–521, 539
 of rectangular solids, 517–518, 539
 of spheres, 519, 539

W

weight
 metric units of, converting between,
 464–465
 U.S. units of converting, 462–465

weighted mean, 409, 421

Weinstein, Lawrence, 78

whole numbers, 2, 103
 addition of, 23–29
 multiplication of, 50–55
 ordering of, 13–15
 rounding of, 15–17
 subtraction of, 37–43

word problems, 95, 252–255, 290–292, 644–648

words
 for decimals, 210–211, 259
 dictionary of mathematical, 648
 to equations, 186
 to numerals, 6–7
 numerals to, 5–6

Y

yard (unit), 433
 conversion from feet, 434
 conversion from meters, 446, 447
 conversion to inches, 433
 conversion to meters, 446, 447, 471
 definition of, 470, 471
 square, 452

Z

zero
 addition and, 24
 division and, 64, 105, 568
 as exponent, 105, 620
 as fraction, 116
 multiplication and, 51, 104, 567
 as origin of number line, 551