

---

# **PUMP HANDBOOK**

---

EDITED BY

**Igor J. Karassik  
Joseph P. Messina  
Paul Cooper  
Charles C. Heald**

**THIRD EDITION**

**McGRAW-HILL**

*New York San Francisco Washington, D.C.  
Auckland Bogotá Caracas Lisbon London  
Madrid Mexico City Milan Montreal New Delhi  
San Juan Singapore Sydney Tokyo Toronto*

*In memory of our good friends and colleagues*  
*William C. Krutzsch*  
*Warren H. Fraser*  
*Igor J. Karassik*

---

**McGraw-Hill**



*A Division of The McGraw-Hill Companies*

Copyright © 2001, 1986, 1976 by The McGraw-Hill Companies, Inc. All rights reserved. Printed in the United States of America. Except as permitted under the United States Copyright Act of 1976, no part of this publication may be reproduced or distributed in any form or by any means, or stored in a data base or retrieval system, without the prior written permission of the publisher.

1 2 3 4 5 6 7 8 9 0 DOC / DOC 0 6 5 4 3 2 1 0

ISBN 0-07-034032-3

The sponsoring editor for this book was Linda Ludewig, the editor supervisor was David Fogarty, and the production supervisor was Pamela A. Pelton. It was set in Century Schoolbook by D&G Limited, LLC.

Printed and bound by R. R. Donnelley & Sons Company.

McGraw-Hill books are available at special quantity discounts to use as premiums and sales promotions, or for use in corporate training programs. For more information, please write to the Director of Special Sales, Professional Publishing, McGraw-Hill, Two Penn Plaza, New York, NY 10121-2298. Or contact your local bookstore.

Information contained in this work has been obtained by The McGraw-Hill Companies, Inc. ("McGraw-Hill") from sources believed to be reliable. However, neither McGraw-Hill nor its authors guarantee the accuracy or completeness of any information published herein and neither McGraw-Hill nor its authors shall be responsible for any errors, omissions, or damages arising out of use of this information. This work is published with the understanding that McGraw-Hill and its authors are supplying information but are not attempting to render engineering or other professional services. If such services are required, the assistance of an appropriate professional should be sought.



This book is printed on recycled, acid-free paper containing a minimum of 50 percent recycled de-inked fiber.

## **OTHER MCGRAW-HILL REFERENCE BOOKS OF INTEREST**

---

### **Handbooks**

Baumeister • *Marks' Standard Handbook for Mechanical Engineers*  
Bovay • *Handbook of Mechanical and Electrical Systems for Buildings*  
Brady and Clauser • *Materials Handbook*  
Brater and King • *Handbook of Hydraulics*  
Chopey and Hicks • *Handbook of Chemical Engineering Calculations*  
Croft, Carr, and Watt • *American Electricians' Handbook*  
Dudley • *Gear Handbook*  
Fink and Beaty • *Standard Handbook for Electrical Engineers*  
Harris • *Shock and Vibration Handbook*  
Hicks • *Standard Handbook of Engineering Calculations*  
Hicks and Mueller • *Standard Handbook of Professional Consulting Engineering*  
Juran • *Quality Control Handbook*  
Kurtz • *Handbook of Engineering Economics*  
Maynard • *Industrial Engineering Handbook*  
Optical Society of America • *Handbook of Optics*  
Pachner • *Handbook of Numerical Analysis Applications*  
Parmley • *Mechanical Components Handbook*  
Parmley • *Standard Handbook of Fastening and Joining*  
Peckner and Bernstein • *Handbook of Stainless Steels*  
Perry and Green • *Perry's Chemical Engineers' Handbook*  
Raznjevic • *Handbook of Thermodynamic Tables and Charts*  
Rohsenow, Hartnett, and Ganic • *Handbook of Heat Transfer Applications*  
Rohsenow, Hartnett, and Ganic • *Handbook of Heat Transfer Fundamentals*  
Rothbart • *Mechanical Design and Systems Handbook*  
Schwartz • *Metals Joining Manual*  
Seidman and Mahrous • *Handbook of Electric Power Calculations*  
Shand and McLellan • *Glass Engineering Handbook*  
Smeaton • *Motor Application and Control Handbook*  
Smeaton • *Switchgear and Control Handbook*  
Transamerica DeLaval, Inc. • *Transamerica DeLaval Engineering Handbook*  
Tuma • *Engineering Mathematics Handbook*  
Tuma • *Technology Mathematics Handbook*  
Tuma • *Handbook of Physical Calculations*

### **Encyclopedias**

*Concise Encyclopedia of Science and Technology*  
*Encyclopedia of Electronics and Computers*  
*Encyclopedia of Engineering*

### **Dictionaries**

*Dictionary of Mechanical and Design Engineering*  
*Dictionary of Scientific and Technical Terms*

## **ABOUT THE EDITORS**

**Igor Karassik**, now deceased, was an original editor of this book. His extensive contributions to the earlier editions remain a signal feature of this edition. A major figure in the pump industry for the greater part of the past century, he also authored or co-authored six books in this field. Beginning in 1936, he wrote more than 600 articles on centrifugal pumps and related subjects, which appeared in over 1500 publications worldwide. For the greater part of his career, he held senior engineering and marketing positions within the Worthington Pump & Machinery Company, which after a number of permutations became part of the Flowserve Corporation. Igor Karassik received his B.S. and M.S. degrees in Mechanical Engineering from Carnegie Mellon University. He was a Life Fellow of the American Society of Mechanical Engineers and recipient of the first ASME Henry R. Worthington Medal (1980).

**Joseph P. Messina**, also one of the original editors, has spent his entire career in the pump industry; and his past contributions on pump and systems engineering continue to be presented in their entirety in this edition. He served as Manager of Applications Engineering at the Worthington Pump Company. He became a Pump Specialist at the Public Service Electric and Gas Company in New Jersey, serving as a committee member of the Electric Power Research Institute to improve the performance of boiler feed pumps. He assisted in updating the Hydraulic Institute Standards and taught centrifugal pump courses. He also taught Fluid and Solid Mechanics at the New Jersey Institute of Technology and holds a B.S. in Mechanical Engineering and an M.S. in Civil Engineering from the same institution. Now a pump technology consultant, he has been a contributor to the technical journals and holds pump-related patents.

**Paul Cooper** has been involved in the pump industry for over forty years. He began by specializing in the hydraulic design of centrifugal pumps and inducers for aerospace applications at TRW Inc. This was followed by a career in research and development on pump hydraulics and cavitation at the Ingersoll-Dresser Pump Company, now part of the Flowserve Corporation, where he conducted investigations at the Ingersoll-Rand Research Center and later served as the director of R&D for the company. A Life Fellow of the ASME, he received that society's Fluid Machinery Design Award (1991) and the Henry R. Worthington Medal (1993). He received his B.S. (Drexel University) and M.S. (Massachusetts Institute of Technology) degrees in Mechanical Engineering and a Ph.D. in Engineering from Case Western Reserve University. Now a consultant, he is the author of many technical papers and holds several patents on pumps.

**Charles C. Heald** has spent his entire career in the pump industry. He conducted the hydraulic and mechanical design of several complete lines of single and multistage pumps for the Cameron Pump Division of Ingersoll-Rand, which became part of the Ingersoll-Dresser Pump Company. He served as Chief Engineer and Manager of Engineering. Currently a consultant, he continues to function as the editor of the company's *Cameron Hydraulic Data Book*. The petroleum industry has always been the focus of his efforts, and he has served for over 35 years as a member of the API 610 specification task force, receiving a resolution of appreciation from API in 1995. A Life Member of the ASME, he obtained the B.S. degree in Mechanical Engineering from the University of Maine, and he is the author of several technical articles and the holder of patents pertaining to pumps.



---

# CONTENTS

---

*List of Contributors* / ix  
*Preface to the Third Edition* / xvii  
*Preface to the Second Edition* / xix  
*Preface to the First Edition* / xxi  
*SI Units—A Commentary* / xxiii

---

**Chapter 1 Introduction: Classification and Selection of Pumps** **1.1**

---

**Chapter 2 Centrifugal Pumps** **2.1**

---

2.1 Centrifugal Pump Theory / 2.3  
2.2 Centrifugal Pump Construction / 2.97  
    2.2.1 Centrifugal Pumps: Major Components / 2.97  
    2.2.2 Centrifugal Pump Packing / 2.183  
    2.2.3 Centrifugal Pump Mechanical Seals / 2.197  
    2.2.4 Centrifugal Pump Injection-Type Shaft Seals / 2.239  
    2.2.5 Centrifugal Pump Oil Film Journal Bearings / 2.247

- 2.2.6 Centrifugal Pump Magnetic Bearings / 2.277
- 2.2.7 Sealless Pumps / 2.295
  - 2.2.7.1 Magnetic Drive Pumps / 2.297
  - 2.2.7.2 Canned Motor Pumps / 2.315
- 2.3 Centrifugal Pump Performance / 2.327
  - 2.3.1 Centrifugal Pumps: General Performance Characteristics / 2.327
  - 2.3.2 Centrifugal Pump Hydraulic Performance and Diagnostics / 2.397
  - 2.3.3 Centrifugal Pump Mechanical Performance, Instrumentation, and Diagnostics / 2.405
  - 2.3.4 Centrifugal Pump Minimum Flow Control Systems / 2.437
- 2.4 Centrifugal Pump Priming / 2.453

### **Chapter 3 Displacement Pumps**

3.1

- 
- 3.1 Power Pump Theory / 3.3
  - 3.2 Power Pump Design and Construction / 3.21
  - 3.3 Steam Pumps / 3.37
  - 3.4 Displacement Pump Performance Instrumentation and Diagnostics / 3.63
  - 3.5 Displacement Pump Flow Control / 3.75
  - 3.6 Diaphragm Pumps / 3.85
  - 3.7 Screw Pumps / 3.99
  - 3.8 Vane, Gear, and Lobe Pumps / 3.123

### **Chapter 4 Jet Pumps**

4.1

- 
- 4.1 Jet Pump Theory / 4.3
  - 4.2 Jet Pump Applications / 4.23

### **Chapter 5 Materials of Construction**

5.1

- 
- 5.1 Metallic Materials of Pump Construction (and Their Damage Mechanisms) / 5.3
  - 5.2 Materials of Construction for Nonmetallic (Composite) Pumps / 5.49

### **Chapter 6 Pump Drivers**

6.1

- 
- 6.1 Prime Movers / 6.3
    - 6.1.1 Electric Motors and Motor Controls / 6.3
    - 6.1.2 Steam Turbines / 6.37
    - 6.1.3 Engines / 6.57
    - 6.1.4 Hydraulic Turbines / 6.77
    - 6.1.5 Gas Turbines / 6.89
  - 6.2 Speed-Varying Devices / 6.99
    - 6.2.1 Eddy-Current Couplings / 6.99

- 6.2.2 Single-Unit Adjustable-Speed Electric Drives / 6.109
- 6.2.3 Fluid Couplings / 6.127
- 6.2.4 Gears / 6.143
- 6.2.5 Adjustable-Speed Belt Drives / 6.167
- 6.3 Power Transmission Devices / 6.175
  - 6.3.1 Pump Couplings and Intermediate Shafting / 6.175
  - 6.3.2 Hydraulic Pump and Motor Power Transmission Systems / 6.191

---

## **Chapter 7 Pump Controls and Valves** **7.1**

---

## **Chapter 8 Pump Systems** **8.1**

- 8.1 General Characteristics of Pumping Systems and System-Head Curves / 8.3
- 8.2 Branch-Line Pumping Systems / 8.83
- 8.3 Waterhammer / 8.91
- 8.4 Pump Noise / 8.109

---

## **Chapter 9 Pump Services** **9.1**

- 9.1 Water Supply / 9.3
- 9.2 Sewage Treatment / 9.25
- 9.3 Drainage and Irrigation / 9.45
- 9.4 Fire Pumps / 9.57
- 9.5 Steam Power Plants / 9.73
- 9.6 Chemical Industry / 9.113
- 9.7 Petroleum Industry / 9.133
- 9.8 Pulp and Paper Mills / 9.157
- 9.9 Food and Beverage Pumping / 9.187
- 9.10 Mining / 9.197
- 9.11 Marine Pumps / 9.215
- 9.12 Refrigeration, Heating, and Air Conditioning / 9.253
- 9.13 Pumped Storage / 9.261
- 9.14 Nuclear / 9.279
  - 9.14.1 Nuclear Electric Generation / 9.279
  - 9.14.2 Nuclear Pump Seismic Qualifications / 9.301
- 9.15 Metering / 9.313
- 9.16 Solids Pumping / 9.321
  - 9.16.1 Hydraulic Transport of Solids / 9.321
  - 9.16.2 Application and Construction of Centrifugal Solids Handling Pumps / 9.351
  - 9.16.3 Construction of Solids-Handling Displacement Pumps / 9.369
- 9.17 Oil Wells / 9.377
- 9.18 Cryogenic Liquefied Gas Service / 9.399

- 9.19 Aerospace / 9.409
  - 9.19.1 Aircraft Fuel Pumps / 9.409
  - 9.19.2 Liquid Rocket Propellant Pumps / 9.431
- 9.20 Portable Transfer of Hazardous Liquids / 9.441
- 9.21 Water Pressure Booster Systems / 9.447
- 9.22 Hydraulic Presses / 9.463

---

**Chapter 10 Intakes and Suction Piping** **10.1**

- 10.1 Intakes, Suction Piping, and Strainers / 10.3
- 10.2 Intake Modeling / 10.39

---

**Chapter 11 Selecting and Purchasing Pumps** **11.1**

---

**Chapter 12 Installation, Operation, and Maintenance** **12.1**

---

**Chapter 13 Pump Testing** **13.1**

---

**Appendix Technical Data** **A.1**

---

**Index** **I.1**

---

---

# LIST OF CONTRIBUTORS\*

---

**Able, Stephen D.**, B.S. (M.E.), MBA, M.S. (Eng) SECTION 3.6 DIAPHRAGM PUMPS  
*Senior Engineering Consultant, Ingersoll-Rand Fluid Products, Bryan, OH*

**Addie, Graeme**, B.S. (M.E.) SUBSECTION 9.16.2 APPLICATION AND CONSTRUCTION  
OF CENTRIFUGAL SOLIDS HANDLING PUMPS  
*Vice President, Engineering and R&D, GIW Industries, Inc., Grovetown, GA*

**Arnold, Conrad L.**, B.S., (E.E.) SUBSECTION 6.2.3 FLUID COUPLINGS  
*Director of Engineering, American Standard Industrial Division, Detroit, MI*

**Ashton, Robert D.**, B.S. (E.T.M.E.) SUBSECTION 2.2.4 CENTRIFUGAL PUMP  
INJECTION-TYPE SHAFT SEALS  
*Manager, Proposal Applications, Byron Jackson Pump Division, Borg-Warner  
Industrial Products, Inc., Long Beach, CA*

**Bean, Robert**, B.A.(Physics), M.S. (M.E.) SECTION 3.6 DIAPHRAGM PUMPS  
*Engineering Manager, Milton Roy Company, Flow Control Division, Ivyland, PA*

**Beck, Wesley W.**, B.S. (C.E.), P.E. CHAPTER 13 PUMP TESTING  
*Hydraulic Consulting Engineer, Denver, CO. Formerly with the Chief Engineers Office  
of the U.S. Bureau of Reclamation*

**Benjes, H. H., Sr.**, B.S. (C.E.), P.E. SECTION 9.2 SEWAGE TREATMENT  
*Retired Partner, Black & Veatch, Engineers-Architects, Kansas City, MO*

\*Note: Positions and affiliations of the contributors generally are those held at the time the respective contributions were made.

- Bergeron, Wallace L.,** B.S. (E.E.) SUBSECTION 6.1.2 STEAM TURBINES  
*Senior Market Engineer, Elliott Company, Jeannette, PA*
- Birgel, W. J.,** B.S. (E.E.) SUBSECTION 6.2.1 EDDY-CURRENT COUPLING  
*President, VS Systems, Inc., St. Paul, MN*
- Birk, John R.,** B.S. (M.E.), P.E. SECTION 9.6 CHEMICAL INDUSTRY  
*Consultant, Senior Vice President (retired), The Duriron Company, Inc., Dayton, OH*
- Brennan, James R.,** B.S. (M.I.E.) SECTION 3.7 SCREW PUMPS; SECTION 9.17 OIL WELLS  
*Manager of Engineering, Imo Pump, a member of the Colfax Pump Group, Monroe, NC*
- Buse, Frederic W.,** B.S. (Marine Engrg.) SECTION 2.2.7.1 SEALLESS PUMPS: MAGNETIC DRIVE PUMPS; SECTION 3.1 POWER PUMP THEORY; SECTION 3.2 POWER PUMP DESIGN AND CONSTRUCTION; SECTION 5.2 MATERIALS OF CONSTRUCTION FOR NONMETALLIC (COMPOSITE) PUMPS; SECTION 9.6 CHEMICAL INDUSTRY  
*Retired Senior Engineering Consultant, Flowserve Corporation, Phillipsburg, NJ*
- Cappellino, C. A.,** B.S. (M.E./I.E.), M.S. (Product Dev't.), P.E. SECTION 9.8 PULP AND PAPER MILLS  
*Engineering Project Manager, ITT Fluid Technology Corp., Industrial Pump Group*
- Chaplis, William K.,** B.S. (M.E.), MBA SECTION 3.1 POWER PUMP THEORY; SECTION 3.2 POWER PUMP DESIGN AND CONSTRUCTION  
*Product Engineering Manager, Flowserve Corporation, Phillipsburg, NJ*
- Clopton, D. E.,** B.S. (C.E.), P.E. SECTION 9.1 WATER SUPPLY  
*Assistant Project Manager, Water Quality Division, URS/Forrest and Cotton, Inc., Consulting Engineers, Dallas, TX*
- Cooper, Paul,** B.S. (M.E.), M.S. (M.E.), Ph.D. (Engrg.), P.E. CHAPTER 1 INTRODUCTION: CLASSIFICATION AND SELECTION OF PUMPS; SECTION 2.1 CENTRIFUGAL PUMP THEORY; SECTION 2.2.6 CENTRIFUGAL PUMP MAGNETIC BEARINGS; SECTION 2.3.1 CENTRIFUGAL PUMPS: GENERAL PERFORMANCE CHARACTERISTICS; SECTION 9.19.2 LIQUID ROCKET PROPELLANT PUMPS  
*Retired Director, Advanced Technology, Ingersoll-Dresser Pumps, now Flowserve Corporation, Phillipsburg, NJ*
- Costigan, James L.,** B.S. (Chem.) SECTION 9.9 FOOD AND BEVERAGE PUMPING  
*Sales Manager, Tri-Clover Division, Ladish Company, Kenosha, WI*
- Cunningham, Richard G.,** B.S. (M.E.), M.S. (M.E.), Ph.D. (M.E.)  
SECTION 4.1 JET PUMP THEORY  
*Vice President Emeritus for Research and Graduate Studies and Professor Emeritus of Mechanical Engineering, Pennsylvania State University, University Park, PA*
- Cutler, Donald B.,** B.S. (M.E.) SUBSECTION 6.3.1 PUMP COUPLINGS AND INTERMEDIATE SHAFTING  
*Technical Services Manager, Rexnord Corporation, Warren, PA*
- Cygnor, John E.,** B.S. (M.E.) SUBSECTION 9.19.1 AIRCRAFT FUEL PUMPS  
*Retired Manager, Advanced Fluid Systems, Hamilton Sundstrand, Rockford, IL*
- Czarnecki, G. J.,** B.Sc., M.Sc. (Tech.) SECTION 3.7 SCREW PUMPS  
*Chief Engineer (Retired), Imo Pump, a member of the Colfax Pump Group, Monroe, NC*
- Dahl, Trygve,** B.S. (M.E.), M.S. (M.E. Systems), Ph.D. (M.E.), P.E.  
CHAPTER 11 SELECTING AND PURCHASING PUMPS  
*Chief Technology Officer, IntellEquip, Inc., Bethlehem, PA. Formerly with Ingersoll-Dresser Pump Co., now part of Flowserve Corporation.*

**DiMasi, Mario**, B.S. (M.E.), M.B.A. SECTION 9.4 FIRE PUMPS

*District Manager, Peerless Pump, Union, NJ*

**Divona, A. A.**, B.S. (M.E.) SUBSECTION 6.1.1 ELECTRIC MOTORS AND  
MOTOR CONTROLS

*Account Executive, Industrial Sales, Westinghouse Electric Corporation, Hillside, NJ*

**Dolan, A. J.**, B.S. (E.E.), M.S. (E.E.), P.E. SECTION 6.1.1 ELECTRIC MOTORS AND  
MOTOR CONTROLS

*Fellow District Engineer, Westinghouse Electric Corporation, Hillside, NJ*

**Dornaus, Wilson L.**, B.S. (C.E.), P.E. SECTION 10.1 INTAKES, SUCTION PIPING,  
AND STRAINERS

*Pump Consultant, Lafayette, CA*

**Drane, John**, C.Eng., M.I. Chem.E. SECTION 9.9 FOOD AND BEVERAGE PUMPING

*Technical Support Engineer, Mono Pumps Limited, Manchester, England, UK*

**Eller, David**, B.S. (A.E.), P.E. SUBSECTION 6.3.2 HYDRAULIC PUMP AND MOTOR  
POWER-TRANSMISSION SYSTEMS

*President and Chief Engineer, M&W, Pump Corporation, Deerfield Beach, FL*

**°Elvitsky, A. W.**, B.S. (M.E.), M.S. (M.E.), P.E. SECTION 9.7 PETROLEUM INDUSTRY

*Vice-President and Chief Engineer, United Centrifugal Pumps, San Jose, CA*

**\*Foster, W. E.**, B.S. (C.E.), P.E. SECTION 9.2 SEWAGE TREATMENT

*Partner, Black & Veatch, Engineers-Architects, Kansas City, MO*

**°Fraser, Warren H.**, B.M.E. SECTION 2.3.2 CENTRIFUGAL PUMP HYDRAULIC  
PERFORMANCE AND DIAGNOSTICS

*Chief Design Engineer, Worthington Pump Group, McGraw-Edison Company,  
Harrison, NJ*

**Freeborough, Robert M.**, B.S. (Min. E.) SECTION 3.3 STEAM PUMPS

*Manager, Parts Marketing, Worthington Corporation, Timonium, MD*

**Furst, Raymond B.** SUBSECTION 9.19.2 LIQUID ROCKET PROPELLANT PUMPS

*Retired Manager of Hydrodynamics, Rocketdyne, now The Boeing Company,  
Canoga Park, CA*

**Giddings, J. F.**, Diploma, Mechanical, Electrical, and Civil Engineering

SECTION 9.8 PULP AND PAPER MILLS

*Development Manager, Parsons & Whittemore, Lyddon, Ltd., Croydon, England*

**Glanville, Robert H.**, M.E. SECTION 9.15 METERING

*Vice President Engineering, BIF, A Unit of General Signal, Providence, RI*

**Guinzburg, Adiel**, B.Sc. (Aero. E.), M.S. (Aero.), Ph.D. (M.E.)

SUBSECTION 9.19.2 LIQUID ROCKET PROPELLANT PUMPS

*Engineering Specialist, Rocketdyne Propulsion & Power, The Boeing Company,  
Canoga Park, CA*

**°Gunther, F. J.**, B.S. (M.E.), M.S. (M.E.) SUBSECTION 6.1.3 ENGINES

*Late Sales Engineer, Waukesha Motor Company, Waukesha, WI*

**Haentjens, W. D.**, B.M.E., M.S. (M.E.), P.E. SECTION 9.10 MINING

*Manager, Special Pumps and Engineering Services, Hazleton Pumps, Inc., Hazleton, PA*

- Hawkins, Larry**, B.S. (M.E.), M.S. (M.E.) SUBSECTION 2.2.6 CENTRIFUGAL PUMP  
MAGNETIC BEARINGS  
*Principal, Calnetix, Torrance, CA*
- Heald, Charles C.**, B.S. (M.E.) SUBSECTION 2.2.1 CENTRIFUGAL PUMPS: MAJOR  
COMPONENTS; SUBSECTION 9.7 PETROLEUM INDUSTRY; SECTION 10.1 INTAKES, SUCTION  
PIPING, AND STRAINERS; CHAPTER 12 INSTALLATION, OPERATION, AND MAINTENANCE  
*Retired Manager of Engineering, Ingersoll-Dresser Pumps, now Flowserve Corporation,  
Phillipsburg, NJ*
- Hendershot, J. R.**, B.S. (Physics) SUBSECTION 6.1.1 ELECTRIC MOTORS AND MOTOR  
CONTROLS; SUBSECTION 6.2.2 SINGLE-UNIT ADJUSTABLE-SPEED ELECTRIC DRIVES  
*President, Motorsoft, Inc., Lebanon, OH*
- Honeycutt, F. G., Jr.**, B.S. (C.E.) P.E. SECTION 9.1 WATER SUPPLY  
*Assistant Vice President and Head Water Quality Division, URS/Forrest and Cotton,  
Inc., Consulting Engineers, Dallas, TX*
- House, D. A.**, B.S. (M.E.) SECTION 9.2 SEWAGE TREATMENT  
*Product Engineering Manager, Flowserve Corporation, Taneytown, MD*
- Ingram, James H.**, B.S. (M.E.), M.S. (M.E.) SUBSECTION 2.3.3 CENTRIFUGAL PUMP  
MECHANICAL PERFORMANCE, INSTRUMENTATION, AND DIAGNOSTICS  
*Senior Engineering Specialist, Monsanto Fibers and Intermediates Company,  
Texas City, TX*
- Jackson, Charles**, B.S. (M.E.), A.A.S. (Electronics), P.E. SUBSECTION 2.3.3  
CENTRIFUGAL PUMP MECHANICAL PERFORMANCE, INSTRUMENTATION, AND DIAGNOSTICS  
*Distinguished Fellow, Monsanto Corporate Engineering, Texas City, TX*
- Jaskiewicz, Stephen A.**, B.A. (Chemistry) SUBSECTION 2.2.7.2 SEALLESS PUMPS:  
CANNED MOTOR PUMPS  
*Product Manager, Chempump (Division of Crane Pumps & Systems, Inc.),  
Warrington, PA*
- Jones, Graham**, B.S. (M.E.), M.B.A. SUBSECTION 2.2.6 CENTRIFUGAL PUMP MAGNETIC  
BEARINGS  
*Former Project Manager for Magnetic Bearings, Technology Insights, San Diego, CA*
- Jones, R. L.**, B.S. (M.E.), M.S. (M.E.), P.E. SUBSECTION 9.7 PETROLEUM INDUSTRY  
*Senior Staff Engineer, Shell Chemical Company, Shell Oil Products Company,  
Houston, TX*
- Jumpeter, Alex M.**, B.S. (Ch.E.) SUBSECTION 4.2 JET PUMP APPLICATIONS  
*Engineering Manager, Process Equipment, Schutte and Koerting Company, Cornwells  
Heights, PA*
- Kalix, David A.**, B.S. (C.E.), P.E. (M.E.) SUBSECTION 2.3.4 CENTRIFUGAL PUMP MINIMUM  
FLOW CONTROL SYSTEMS  
*Senior Product Development Engineer, Yarway Corporation, Blue Bell, PA*
- Karassik, Igor J.**, B.S. (M.E.), M.S. (M.E.), P.E. SUBSECTION 2.2.1 CENTRIFUGAL  
PUMPS: MAJOR COMPONENTS; SECTION 2.4 CENTRIFUGAL PUMP PRIMING; SECTION 9.5  
STEAM POWER PLANTS; CHAPTER 12 INSTALLATION, OPERATION, AND MAINTENANCE  
*Chief Consulting Engineer, Worthington Group, McGraw-Edison Company, Basking  
Ridge, NJ*



- Kawohl, Rudolph**, Dipl. Ing. SECTION 9.4 FIRE PUMPS  
*Retired Engineering Manager, Ingersoll-Dresser Pumps, now Flowserve Corporation, Arnage, France*
- Kittredge, C. P.**, B.S. (C.E.), Doctor of Technical Science (M.E.) SUBSECTION 2.3.1  
CENTRIFUGAL PUMPS: GENERAL PERFORMANCE CHARACTERISTICS  
*Consulting Engineer, Princeton, NJ*
- Koch, Richard P.**, B.S. (M.E.) SECTION 9.5 STEAM POWER PLANTS  
*Manager of Engineering, Pump Services Group, Flowserve Corporation, Phillipsburg, NJ*
- Kron, H. O.**, B.S. (M.E.), P.E. SUBSECTION 6.2.4 GEARS  
*Executive Vice President, Philadelphia Gear Corporation, King of Prussia, PA*
- \*Kurtzsch, W. C.**, B.S. (M.E.), P.E. SI UNITS—A COMMENTARY; CHAPTER 1 INTRODUCTION: CLASSIFICATION AND SELECTION OF PUMPS  
*Late Director, Research and Development, Engineered Products, Worthington Pump Group, McGraw-Edison Company, Harrison, NJ*
- Landon, Fred K.**, B.S. (Aero. E.), P.E. SUBSECTION 6.3.1 PUMP COUPLINGS AND INTERMEDIATE SHAFTING  
*Manager, Engineering, Rexnord, Inc., Houston, TX*
- Larsen, Johannes**, B.S. (C.E.), M.S. (M.E.) SECTION 10.2 INTAKE MODELING  
*Retired Vice President, Alden Research Laboratory, Inc., Holden, MA*
- Lippincott, J. K.**, B.S. (M.E.) SECTION 3.7 SCREW PUMPS  
*Vice President, General Manager (Retired), Imo Pump, a member of the Colfax Pump Group, Monroe, NC*
- Little, C. W., Jr.**, B.E. (E.E.), D. Eng. SECTION 3.8 VANE, GEAR, AND LOBE PUMPS  
*Former Vice President, General Manager, Manufactured Products Division, Waukesha Foundry Company, Waukesha, WI*
- Maxwell, Horace J.**, B.S. (M.E.) SUBSECTION 2.3.4 CENTRIFUGAL PUMP MINIMUM FLOW CONTROL SYSTEMS  
*Director of Engineering, Yarway Corporation, Blue Bell, PA*
- Mayo, Howard A., Jr.**, B.S. (M.E.), P.E. SUBSECTION 6.1.4 HYDRAULIC TURBINES; SECTION 9.13 PUMPED STORAGE  
*Consulting Engineer, Hydrodynamics Ltd., York, PA*
- McCaul, Colon O.**, B.S., M.S. (Metallurgical Engrg.), P.E. SECTION 5.1 METALLIC MATERIALS OF PUMP CONSTRUCTION  
*Senior Engineering Consultant, Flowserve Corporation, Phillipsburg, NJ*
- Messina, Joseph P.**, B.S. (M.E.), M.S. (C.E.), P.E. SECTION 8.1 GENERAL CHARACTERISTICS OF PUMPING SYSTEMS AND SYSTEM-HEAD CURVES; SECTION 8.2 BRANCH-LINE PUMPING SYSTEMS  
*Consultant*
- Miller, Ronald S.**, B.Sc. (M.E.), B.Sc. (Metallurgical Engrg.)  
SECTION 5.1 METALLIC MATERIALS OF PUMP CONSTRUCTION  
*Manager, Advanced Materials Engineering, Ingersoll-Rand Company*
- Moll, Steven A.**, B.S. (E.E.) SECTION 6.2.1 EDDY-CURRENT COUPLINGS  
*Senior Marketing Representative, Electric Machinery, Minneapolis, MN*

\*Deceased.

- Moyes, Thomas L.**, B.S. (M.E.) SUBSECTION 9.18 CRYOGENIC LIQUEFIED GAS SERVICE  
*Chief Engineer - R&D, Flowserve Corporation, Tulsa, OK*
- Netzel, James P.**, B.S. (M.E.) SUBSECTION 2.2.2 CENTRIFUGAL PUMP PACKING;  
SUBSECTION 2.2.3 CENTRIFUGAL PUMPS: MECHANICAL SEALS  
*Chief Engineer, John Crane, Inc., Morton Grove, IL*
- Nolte, P. A.**, B.S. (M.E.) SECTION 9.20 PORTABLE TRANSFER OF HAZARDOUS LIQUIDS  
*Director of Agricultural Business, Flowserve Corporation, Memphis, TN*
- Nuta, D.**, B.S. (C.E.), M.S. (Applied Mathematics and Computer Science), P.E.  
SUBSECTION 9.14.2 NUCLEAR PUMP SEISMIC QUALIFICATIONS  
*Associate Consulting Engineer, Ebasco Services, Inc., New York, NY*
- O'Keefe, W.**, A.B., P.E. SUBSECTION 2.3.4 CENTRIFUGAL PUMP MINIMUM FLOW  
CONTROL SYSTEMS; CHAPTER 7 PUMP CONTROLS AND VALVES  
*Editor, Power Magazine, McGraw-Hill Publications Company, New York, NY*
- Olson, Richard G.**, M.E. M.S., P.E. SECTION 6.1.5 GAS TURBINES  
*Late Marketing Supervisor, International Turbine Systems, Turbodyne Corporation,  
Minneapolis, MN*
- Padmanabhan, Mahadevan**, B.S. (C.E.), M.S. (C.E.), Ph.D., P.E.  
SECTION 10.2 INTAKE MODELING  
*Vice President, Alden Research Laboratory, Inc. Holden, MA*
- Parmakian, John**, B.S. (M.E.), M.S. (C.E.), P.E. SECTION 8.3 WATERHAMMER  
*Consulting Engineer, Boulder, CO*
- Parry, W. E., Jr.**, B.S. (M.E.), P.E. SUBSECTION 9.14.1 NUCLEAR ELECTRICAL GENERATION;  
SUBSECTION 9.14.2 NUCLEAR PUMP SEISMIC QUALIFICATIONS  
*Project Engineering Manager, Nuclear Equipment / Vertical Pumps, Flowserve  
Corporation, Phillipsburg, NJ*
- Patel, Vinod P.**, B.S. (M.E.), M.S. (Metallurgical Engrg.), P.E.  
CHAPTER 11 SELECTING AND PURCHASING PUMPS  
*Senior Principal Engineer, Machinery Technology, Kellogg Brown & Root, Inc.,  
Houston, TX*
- Peacock, James H.**, B.S. (Met.E.) SECTION 9.6 CHEMICAL INDUSTRY  
*Manager, Materials Division, The Duriron Company, Inc., Dayton, OH*
- Platt, Robert A.**, B.E., M.E., P.E. SECTION 3.8 VANE, GEAR AND LOBE PUMPS  
*General Manager, Sales and Marketing, Carver Pump Company, Muscatine, IA*
- Potthoff, E. O.**, B.S. (E.E.), P.E. SUBSECTION 6.2.2 SINGLE-UNIT ADJUSTABLE-SPEED  
ELECTRIC DRIVES  
*Industrial Engineer (retired), Industrial Sales Division, General Electric Company,  
Schenectady, NY*
- Prang, A. J.** SECTION 3.7 SCREW PUMPS  
*Manager, Engineering and Quality Assurance, Flowserve Corporation, Brantford,  
Ontario, Canada*
- Ramsey, Melvin A.**, M.E., P.E. SECTION 9.12 REFRIGERATION, HEATING, AND  
AIR CONDITIONING  
*Consulting Engineer, Schenectady, NY*

- °Rich, George R.**, B.S. (C.E.), C.E., D.Eng., P.E. SECTION 9.13 PUMPED STORAGE  
*Late Director, Senior Vice President, Chief Engineer, Chas. T. Main, Inc., Boston, MA*
- Robertson, John S.**, B.S. (C.E.), P.E. SECTION 9.3 DRAINAGE AND IRRIGATION  
*Chief, Electrical and Mechanical Branch, Engineering and Construction, Headquarters,  
U.S. Army Corps of Engineers*
- Roll, Daniel R.**, B.S. (M.E.), P.E. SECTION 9.8 PUMP AND PAPER MILLS  
*Vice President, Engineering & Development, Finish Thompson Inc, Erie, PA*
- Rupp, Warren E.** SECTION 3.6 DIAPHRAGM PUMPS  
*President, The Warren Rupp Company, Mansfield, OH*
- Sellgren, Anders**, M.S. (C.E.), Ph.D. (Hydraulics) SUBSECTION 9.16.1 HYDRAULIC  
TRANSPORT OF SOLIDS; SUBSECTION 9.16.2 APPLICATION AND CONSTRUCTION OF CENTRIFUGAL  
SOLIDS HANDLING PUMPS  
*Professor, Division of Water Resources Engineering, Lulea University of Technology,  
Lulea, Sweden*
- Semler, William J.**, B.S. (Marine Eng.), M.S. (M.E.) SECTION 9.11 MARINE PUMPS  
*Tenured Associate Professor, United States Merchant Marine Academy, Kings Point, NY*
- Shapiro, Wilbur**, B.S., M.S. SUBSECTION 2.2.5 CENTRIFUGAL PUMP OIL FILM  
JOURNAL BEARINGS  
*Consultant, Machinery Components, Niskayuna, NY*
- Shikasho, Satoru**, B.S. (M.E.), P.E. SECTION 9.21 WATER PRESSURE BOOSTER SYSTEMS  
*Chief Product Engineer, Packaged Products, ITT Bell & Gossett, Morton Grove, IL*
- Smith, L. R.** SECTION 9.18 CRYOGENIC LIQUIFIED GAS SERVICE  
*Retired, formerly of J. C. Carter Company, Costa Mesa, CA*
- Smith, Will**, B.S. (M.E.), M.S. (M.E.), P.E. SECTION 3.5 DISPLACEMENT PUMP FLOW  
CONTROL; SUBSECTION 9.16.3 CONSTRUCTION OF SOLIDS-HANDLING DISPLACEMENT PUMPS  
*Engineering Product Manager, Custom Pump Operations, Worthington Division,  
McGraw-Edison Company, Harrison, NJ*
- Snyder, Milton B.**, B.S. (B.A.) SUBSECTION 6.2.5 ADJUSTABLE-SPEED BELT DRIVES  
*Sales Engineer, Master-Reeves Division, Reliance Electric Company, Columbus, IN*
- Sparks, Cecil R.**, B.S. (M.E.), M.S. (M.E.), P.E. SECTION 8.4 PUMP NOISE  
*Director of Engineering Physics, Southwest Research Institute, San Antonio, TX*
- Szenasi, Fred R.**, B.S. (M.E.), M.S. (M.E.), P.E. SECTION 3.4 DISPLACEMENT PUMP  
PERFORMANCE, INSTRUMENTATION, AND DIAGNOSTICS; SECTION 8.4 PUMP NOISE  
*Senior Project Engineer, Engineering Dynamics Inc., San Antonio, TX*
- Taylor, Ken W.**, MIProdE. CEng. SECTION 9.15 METERING  
*Vice President, Global Business Development, Wayne Division, Dresser Equipment  
Group, a Halliburton Company*
- Tullo, C. J.**, P.E. SECTION 2.4 CENTRIFUGAL PUMP PRIMING  
*Chief Engineer (retired), Centrifugal Pump Engineering, Worthington Pump, Inc.,  
Harrison, NJ*
- Vance, William M.**, M.B.A. SECTION 9.17 OIL WELLS  
*Senior Project Sales Engineer, Weir Pumps Limited, Glasgow, Scotland, UK*

°Deceased.

**VanLanningham, F. L.**, SECTION 6.2.4 GEARS

*Consultant, Rotating and Turbomachinery Consultants*

**Wachel, J. C.**, B.S. (M.E.), M.S. (M.E.) SECTION 3.4 DISPLACEMENT PUMP

PERFORMANCE, INSTRUMENTATION, AND DIAGNOSTICS; SECTION 8.4 PUMP NOISE  
*Manager of Engineering, Engineering Dynamics, Inc., San Antonio, TX*

**Webb, Donald R.**, B.S. (M.E.), M.S. (Engrg Administration) SUBSECTION 6.1.4

HYDRAULIC TURBINES

*Plant Assessment Manager, Voith Siemens Hydro, York, PA*

**Wepfer, W. M.**, B.S. (M.E.), P.E. SUBSECTION 9.14.1 NUCLEAR ELECTRICAL GENERATION

*Consulting Engineer, formerly Manager, Pump Design, Westinghouse Electric Corporation, Pittsburgh, PA*

**Whippen, Warren G.**, B.S. (M.E.), P.E. SUBSECTION 6.1.4 HYDRAULIC TURBINES

*Retired Manager of Hydraulic Engineering, Voith Siemens Hydro, York, PA*

**Wilson, Kenneth C.**, B.A.Sc. (C.E.), M.Sc.(Hydraulics), Ph.D. SUBSECTION 9.16.1

HYDRAULIC TRANSPORT OF SOLIDS

*Professor Emeritus, Dept. of Civil Engineering, Queen's University, Kingston, Ontario, Canada*

**Wotring, Timothy L.**, B.S. (M.E.), P.E. SUBSECTION 2.2.4 CENTRIFUGAL PUMP

INJECTION-TYPE SHAFT SEALS

*Engineering Manager, Flowserve Corporation, Phillipsburg, NJ*

**Zeitlin, A. B.**, M.S. (M.E.), Dr.-Eng. (E.E.), P.E. SECTION 9.22 HYDRAULIC PRESSES

*President, Press Technology Corporation, Mamaroneck, NY*

---

# PREFACE

# TO THE THIRD EDITION

---

It is difficult to follow in the footsteps of Igor J. Karassik, whose vision and leadership played a major role in the concept of a handbook on pumps that is broad enough to encompass all aspects of the subject—from the theory of operation through design and application to the multitude of tasks for which pumps of all types and sizes are employed. That vision was realized in the first edition of the *Pump Handbook*, which appeared a quarter-century ago, with the capable and dedicated co-authorship of William C. Krutzsch, Warren H. Fraser, and Joseph P. Messina. Acceptance of this work globally soon led these distinguished pump engineers to assemble a second edition that not only contained updated material but also presented all numerical quantities in terms of the SI system of units in addition to the commonly used United States customary system of units.

Worldwide developments in pump theory, design and applications have continued to emerge, and these have begun to affect the outlook of pump engineers and users to such an extent that a third edition has become overdue. Pumps have continued to grow in size, speed, and energy level, revealing new problems that are being addressed by innovative materials and mechanical and hydraulic design approaches. Environmental pressures have increased, and these can and are being responded to by the creative attention of pump engineers and users. After all, the engineer is trained to solve problems, employing techniques that reflect knowledge of physical phenomena in the world around us. All of this has led the current authors to respond by adding new sections and by revising most of the others as would be appropriate in addressing these developments. Specifically the following changes should be noted.

Centrifugal pump theory, in the rewritten Section 2.1, proceeds from the basic governing fluid mechanics to the rationale that underlies the fundamental geometry and performance of these machines—while maintaining the concrete illustrations of design examples. A new subsection on high-energy pumps is included.

An update has been made to Section 2.2.1 on major components of centrifugal pumps.

Section 2.3.1 on centrifugal pump general performance characteristics has been updated.

The emerging technology of magnetic bearings is presented in the new Section 2.2.6.

Section 2.2.7, is a new treatment of sealless centrifugal pumps that includes both the canned-motor and magnetically-coupled types.

Chapter 3 on displacement pumps has been reorganized and includes updates of the sections on both reciprocating and rotary positive displacement pumps.

A new Section 4.1 on jet pump theory begins the chapter on jet pumps and deals with liquids and gases for the motive and secondary flows as well as the basics of design optimization.

Chapter 5 on materials of construction, including the Sections 5.1 and 5.2 on metallic and nonmetallic materials respectively, has been completely rewritten and updated.

Chapter 6 on pump drivers has been updated, Section 6.1.1 on electric motors and Section 6.2.2 on adjustable-speed electric drives having been substantially rewritten.

In Chapter 9 on pump services, most of the applications sections have been updated, including those for fire pumps (Section 9.4) and pumps for steam power plants (9.5), pulp and paper (9.8), mining (9.10), metering (9.15), pumped storage (9.13), and nuclear services (9.14).

Section 9.11 on marine applications has been rewritten.

Sections 9.16.1 on hydraulic transport of solids and 9.16.2 on centrifugal slurry pumps are completely new and include several examples.

A new section on aerospace pumps has been added, which includes Sections 9.19.1 on aircraft fuel pumps and 9.19.2 on liquid rocket propellant pumps.

Section 9.20 on handling hazardous liquids is new.

Chapters 10 on intakes and suction piping, 11 on selecting and purchasing pumps and 12 on installation, operation, and maintenance have been updated.

We recognize that further developments are going on apace and that more could have been done. *Computational fluid dynamics* (CFD) and finite-element structural and rotor-dynamic analysis techniques, as well as the revolution in information management and utilization, already promise to profoundly transform pump design, application, and operational practice—and indeed all other areas of engineering endeavor. Nevertheless, we offer this third edition of the *Pump Handbook* as a practical tool for the present day. In this sense, we hope that it will fulfill the vision of the authors of prior editions while at the same time serving as a stepping stone to the future world of pumping.

PAUL COOPER

---

# PREFACE

# TO THE SECOND EDITION

---

Once more, the dubious honor of writing a preface has been bestowed upon me by my three co-editors. And while they are perfectly willing to share the pluses and minuses of collective editorship, they refused to engage in collective “prefaceship,” if I may be allowed to coin a word. At best, they reserved for themselves the right of looking over my shoulder and criticizing the spirit of levity with which I chose to approach the task for which they had unanimously volunteered me. I should add parenthetically that the preface of the first edition (which you can read on the following pages) is actually my fourth draft; the first three were judged too irreverent by my co-editors. (I have preserved these first three drafts for whoever inherits my collection of unpublished material.)

Assuming that my co-editors are more charitable this time, or alternately that our publisher is pressed for time, what follows (if not what precedes) will appear more or less as written.

First of all, we would like to assure the readers of this second edition of the *Pump Handbook* that it is not merely a slightly warmed-over version of the first edition, with such errata as we have spotted corrected and with a few insignificant changes and additions. Actually, the task of rewriting and editing the material in a form that would correspond to what was planned for this second edition proved to be a monumental, not to say awesome, undertaking.

To begin with, in concert with the publishers, it was decided that all data given here would appear in both USCS and SI units. This was not as simple a task as it may appear, for the reason that “absolute” pure SI units do not lend themselves well to the scale of numbers generally encountered in industrial processes. To give but one example, the pascal, which is the SI unit of pressure, corresponds to 0.000145 lb/in<sup>2</sup>, and even the kilopascal is only 0.145 lb/in<sup>2</sup>. Although this might be a reasonably satisfactory unit for scientific work, the case is hardly such for centrifugal pumps used in everyday life.

This led us to choose what might be called a modified set of SI units, all as explained in “SI Units—A Commentary,” on page xxi. Even conveying this desirable concept of a practical set of SI units to the authors of various sections proved to be somewhat difficult.

As a result, we have permitted these authors some leeway in their specific choice, understanding full well that what is desirable in one industry may differ from the preferred choice in another.

We decided that a number of sections and subsections in the first edition could benefit by being significantly expanded. This, for instance, is the case with the following:

- 2.2.1 "Centrifugal Pumps: Major Components"
- 2.3.1 "Centrifugal Pumps: General Performance Characteristics"
- 2.4 "Centrifugal Pump Priming"
- 8.1 "General Characteristics of Pumping Systems and System-Head Curves"
- 8.4 "Pump Noise"
- 9.4 "Fire Pumps"
- 9.15.1 "Nuclear Electric Generation"
- 9.17.1 "Hydraulic Transport of Solids"
- 10.1 "Intakes, Suction Piping, and Strainers"
- Appendix "Technical Data"

At the same time, we felt that some material originally included in the subsection "Centrifugal Pumps: Major Components" should be excised from there and treated in greater depth separately.

This expanded coverage includes the following:

- 2.2.2 "Centrifugal Pump Packing"
- 2.2.3 "Centrifugal Pump Mechanical Seals"
- 2.2.4 "Centrifugal Pump Injection-Type Shaft Seals"
- 2.2.5 "Centrifugal Pump Oil Film Journal Bearings"

Finally, a large amount of subject matter has been added to the second edition:

- 2.3.2 "Centrifugal Pump Hydraulic Performance and Diagnostics"
- 2.3.3 "Centrifugal Pump Mechanical Performance, Instrumentation, and Diagnostics"
- 2.3.4 "Centrifugal Pump Minimum Flow Control Systems"
- 3.3 "Diaphragm Pumps"
- 3.6 "Displacement Pump Performance, Instrumentation, and Diagnostics"
- 3.7 "Displacement Pump Flow Control"
- 5.2 "Materials of Construction of Nonmetallic Pumps"
- 6.3.2 "Magnetic Drives"
- 6.3.3 "Hydraulic Pump and Motor Power Transmission Systems"
- 9.15.2 "Nuclear Pump Seismic Qualifications"
- 9.17.3 "Construction of Solids-Handling Displacement Pumps"
- 9.18 "Oil Wells"
- 9.19 "Cryogenic Liquefied Gas Service"
- 9.20 "Water Pressure Booster Systems"
- 10.2 "Intake Modeling"

In brief, the editors have attempted to increase the usefulness of this handbook. The extent to which we have achieved this objective, we will leave to the judgment of our readers.



---

# PREFACE TO THE FIRST EDITION

---

Considering that I had written the prefaces of the three books published so far under my name, my colleagues thought it both polite and expedient to suggest that I prepare the preface to this handbook, coedited by the four of us. Except for the writing of the opening paragraph of an article, a preface is the most difficult assignment that I know. Certainly the preface to a handbook should do more than describe minutely and in proper order the material that is contained therein.

Yet I submit that the saying “a book should not be judged by its cover” should be expanded by adding “and not by its preface.” If the reader will accept this disclaimer, I can proceed.

As will be stated in Section 1, “Introduction and Classification of Pumps,” it can rightly be claimed that no machine and very few tools have had as long a history in the service of man as the pump, or have filled as broad a need in his life. Every process which underlies our modern civilization involves the transfer of liquids from one level of pressure or static energy to another. Pumps have played an essential role in our life ever since the dawn of civilization.

Thus it is that a constantly growing number of technical personnel is in need of information that will help them in either designing, selecting, operating, or maintaining pumping equipment. There has never been a dearth of excellent books and articles on the subject of pumps. But the editors and the publisher felt that a need existed for a handbook on pumps that would present this information in a compact and authoritative form. The format of a handbook permits a selection of the most versatile group of contributors, each an expert on his particular subject, each with a background of experience that makes him particularly knowledgeable in the area assigned to him.

This handbook deals first with the theory, construction details, and performance characteristics of all the major types of pumps—centrifugal pumps, power pumps, steam pumps, screw and rotary pumps, jet pumps, and many of their variants. It deals with prime movers, couplings, controls, valves, and the instruments used in pumping systems.

It treats in detail the systems in which pumps operate and the characteristics of these systems. And because of the many services in which pumps have to be applied, a total of 21 different services—ranging from water supply to steam power plants, construction, marine applications, and refrigeration to metering and solids pumping—are examined and described in detail, again by a specialist in each case.

Finally, the handbook provides information on the selection, purchasing, installation, operation, testing, and maintenance of pumps. An appendix provides a variety of technical data useful to anyone dealing with pumping equipment.

We are greatly indebted to the men who supplied the individual sections that make up this handbook. We hope that our common task will have produced a handbook that will help its user to make a better and more economical pump installation than he or she would have done without it, to install equipment that will perform more satisfactorily and for longer uninterrupted periods, and when trouble occurs, to diagnose it quickly and accurately. If this handbook does all this, the contributors, its editors, and its publisher will be pleased and satisfied.

No doubt a few readers will look for subject matter that they will not find in this handbook. Into the making of decisions on what to include and what to leave out must always enter an element of personal opinion; therefore we will feel some responsibility for their disappointment. But we submit that it was quite impossible to include even everything we had wanted to cover. As to our possible sins of commission, they are obviously unknown to us at this writing. We can only promise that we shall correct them if an opportunity is afforded to us.

IGOR J. KARASSIK

---

# SI UNITS— A COMMENTARY

W.C. KRUTZSCH  
P. COOPER

Since the publication of the first edition of this handbook in 1976, the involvement of the world in general, and of the United States in particular, with the SI system of units has become quite common. Accordingly, throughout this book, SI units have been provided as a supplement to the United States customary system of units (USCS). This should make it easier, particularly for readers in metric countries, who will no longer find it necessary to make either approximate mental transpositions or exact mathematical conversions.

The designation SI is the official abbreviation, in any language, of the French title “Le Système International d’Unités,” given by the 11th General Conference on Weights and Measures (sponsored by the International Bureau of Weights and Measures) in 1960 to a coherent system of units selected from metric systems. This system of units has since been adopted by the International Organization for Standardization (ISO) as an international standard.

The SI system consists of seven basic units, two supplementary units, a series of derived units, and a series of approved prefixes for multiples and submultiples of the foregoing. The names and definitions of the basic and supplementary units are contained in Tables 1a and 1b of the Appendix. Table 2 lists the units and Table 3 the prefixes. Table 10 provides conversions of USCS to SI units.

As with the second edition, the decision has been made to accept variations in the expression of SI units that are widely encountered in practice. The quantities mainly affected are pressure and flow rate, the situation with each being explained as follows.

The standard SI unit of pressure, the pascal, equal to one newton<sup>†</sup> per square meter<sup>‡</sup>, is a minuscule value relative to the pound per square inch ( $1 \text{ lb/in}^2 = 6,894.757 \text{ Pa}$ ) or to the old, established metric unit of pressure the kilogram per square centimeter ( $1 \text{ kgf/cm}^2 =$

<sup>†</sup>The newton (symbol N) is the SI unit of force, equal to that which, when applied to a body having a mass of 1 kg, gives it an acceleration of  $1 \text{ m/s}^2$ .

<sup>‡</sup>In countries using the SI system exclusively, the correct spelling is *metre*. This book uses the spelling *meter* in deference to prevailing U.S. practice.

98,066.50 Pa). In order to eliminate the necessity for dealing with significant multiples of these already large numbers when describing the pressure ratings of modern pumps, different sponsoring groups have settled on two competing proposals. One group supports selection of the kilopascal, a unit which does provide a numerically reasonable value ( $1 \text{ lb/in}^2 = 6.894757 \text{ kPa}$ ) and is a rational multiple of a true SI unit. The other group, equally vocal, supports the bar ( $1 \text{ bar} = 10^5 \text{ Pa}$ ). This support is based heavily on the fact that the value of this special derived unit is close to one atmosphere. It is important, however, to be aware that it is not exactly equal to a standard atmosphere ( $101,325.0 \text{ Pa}$ ) or to the so-called metric atmosphere ( $1 \text{ kgf/cm}^2 = 98,066.50 \text{ Pa}$ ), but is close enough to be confused with both.

As yet, there is no consensus about which of these units should be used as the standard. Accordingly, both are used, often in the same metric country. Because the world cannot agree and because we must all live with the world as it is, the editors concluded that restricting usage to one or the other would be arbitrary, grossly artificial, and not in the best interests of the reader. We therefore have permitted individual authors to use what they are most accustomed to, and both units will be encountered in the text.

Units of pressure are utilized to define both the performance and the mechanical integrity of displacement pumps. For kinetic pumps, however, which are by far the most significant industrial pumps, pressure is used only to describe rated and hydrostatic values, or mechanical integrity. Performance is generally measured in terms of total head, expressed as feet in USCS units and as meters in SI units. This sounds straightforward enough until a definition of head, including consistent units, is attempted. Then we encounter the dilemma of mass versus force, or weight.

The total head developed by a kinetic pump, or the head contained in a vertical column of liquid, is actually a measure of the internal energy added to or contained in the liquid. The units used to define it could be energy per unit volume, or energy per unit mass, or energy per unit weight. If we select the last, we arrive conveniently, in USCS units, as foot-pounds per pound, or simply feet. In SI units, the terms would be newton-meters per newton, or simply meters. In fact, however, metric countries weigh objects in kilograms, not newtons, and so the SI term for head may be defined at places in this volume in terms of kilogram-meters per kilogram, even though this does not conform strictly to SI rules.

Similar ambiguity is observed with the units of flow rate, except here there may be even more variations. The standard SI unit of flow rate is the cubic meter per second, which is indeed a very large value ( $1 \text{ m}^3/\text{s} = 15,850.32 \text{ U.S. gal/min}$ ) and is therefore really only suitable for very large pumps. Recently, some industry groups have suggested that a suitable alternative might be the liter per second ( $1 \text{ l/s} = 10^{-3} \text{ m}^3/\text{s} = 15.85032 \text{ U.S. gal/min}$ ), while others have maintained strong support for the traditional metric unit of flow rate, the cubic meter per hour ( $1 \text{ m}^3/\text{h} = 4.402867 \text{ U.S. gal/min}$ ). All of these units will be encountered in the text.

These variations have led to several forms of the specific speed, which is the fundamentally dimensionless combination of head, flow rate, and rotative speed that characterizes the geometry of kinetic pumps. These forms are all related to a truly unitless formulation called "universal specific speed," which gives the same numerical value for any consistent system of units. Although not yet widely used, this concept has been appearing in basic texts and other literature, because it applies consistently to all forms of turbomachinery. Equivalencies of the universal specific speed to the common forms of specific speed in use worldwide are therefore provided in this book. This is done with a view to eventual standardization of the currently disparate usage in a world that is experiencing globalization of pump activity.

The value for the unit of horsepower (hp) used throughout this book and in the United States is the equivalent of 550 foot pounds (force) per second, or 0.74569987 kilowatts (kW). The horsepower used herein is approximately 1.014 times greater than the metric horsepower, which is equivalent to 0.735499 kilowatts. Whenever the rating of an electric motor is given in this book in horsepower, it is the output rating. The equivalent output power in kilowatts is shown in parentheses.

Variations in SI units have arisen because of differing requirements in various user industry groups. Practices in the usage of units will continue to change, and the reader will have to remain alert to further variations of national and international practices in this area.

C • H • A • P • T • E • R • 1

**INTRODUCTION:  
CLASSIFICATION  
AND  
SELECTION  
OF  
PUMPS**

**W. C. Krutzch**

**Paul Cooper**

## INTRODUCTION

---

Only the sail can contend with the pump for the title of the earliest invention for the conversion of natural energy to useful work, and it is doubtful that the sail takes precedence. Because the sail cannot, in any event, be classified as a machine, the pump stands essentially unchallenged as the earliest form of machine for substituting natural energy for human physical effort.

The earliest pumps we know of are variously known, depending on which culture recorded their description, as *Persian wheels*, *waterwheels*, or *norias*. These devices were all undershot waterwheels containing buckets that filled with water when they were submerged in a stream and that automatically emptied into a collecting trough as they were carried to their highest point by the rotating wheel. Similar waterwheels have continued in existence in parts of the Orient even into the twentieth century.

The best-known of the early pumps, the Archimedean screw, also persists into modern times. It is still being manufactured for low-head applications where the liquid is frequently laden with trash or other solids.

Perhaps most interesting, however, is the fact that with all the technological development that has occurred since ancient times, including the transformation from water power through other forms of energy all the way to nuclear fission, the pump remains probably the second most common machine in use, exceeded in numbers only by the electric motor.

Because pumps have existed for so long and are so widely used, it is hardly surprising that they are produced in a seemingly endless variety of sizes and types and are applied to an apparently equally endless variety of services. Although this variety has contributed to an extensive body of periodical literature, it has also tended to preclude the publication of comprehensive works. With the preparation of this handbook, an effort has been made to create just such a comprehensive source.

Even here, however, it has been necessary to impose a limitation on subject matter. It has been necessary to exclude material uniquely pertinent to certain types of auxiliary pumps that lose their identity to the basic machine they serve and where the user controls neither the specification, purchase, nor operation of the pump. Examples of such pumps would be those incorporated into automobiles or domestic appliances. Nevertheless, these pumps do fall within classifications and types covered in the handbook, and basic information on them may therefore be obtained herein after the type of pump has been identified. Only specific details of these highly proprietary applications are omitted.

Such extensive coverage has required the establishment of a systematic method of classifying pumps. Although some rare types may have been overlooked in spite of all precautions, and obsolete types that are no longer of practical importance have been deliberately omitted, principal classifications and subordinate types are covered in the following section.

## CLASSIFICATION OF PUMPS

---

Pumps may be classified on the basis of the applications they serve, the materials from which they are constructed, the liquids they handle, and even their orientation in space. All such classifications, however, are limited in scope and tend to substantially overlap each other. A more basic system of classification, the one used in this handbook, first defines the principle by which energy is added to the fluid, goes on to identify the means by which this principle is implemented, and finally delineates specific geometries commonly employed. This system is therefore related to the pump itself and is unrelated to any consideration external to the pump or even to the materials from which it may be constructed.

Under this system, all pumps may be divided into two major categories: (1) dynamic, in which energy is continuously added to increase the fluid velocities within the machine

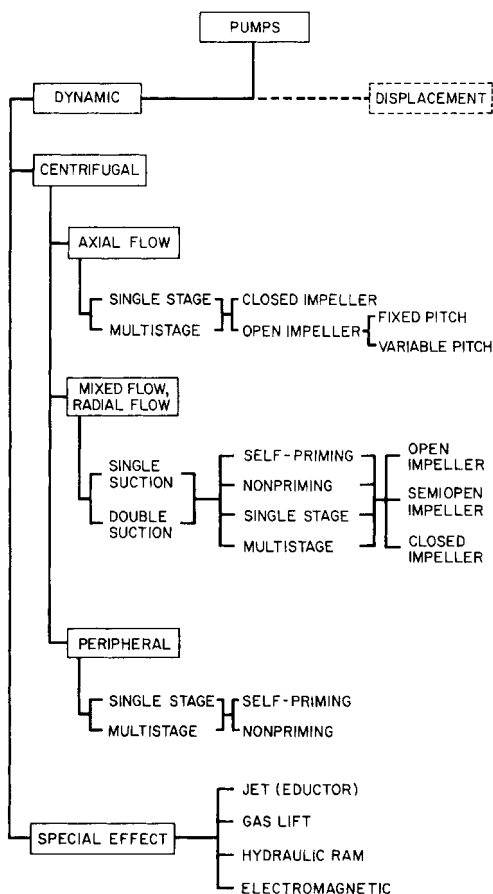


FIGURE 1 Classification of dynamic pumps

to values greater than those occurring at the discharge so subsequent velocity reduction within or beyond the pump produces a pressure increase, and (2) displacement, in which energy is periodically added by application of force to one or more movable boundaries of any desired number of enclosed, fluid-containing volumes, resulting in a direct increase in pressure up to the value required to move the fluid through valves or ports into the discharge line.

Dynamic pumps may be further subdivided into several varieties of centrifugal and other special-effect pumps. Figure 1 presents in outline form a summary of the significant classifications and subclassifications within this category.

Displacement pumps are essentially divided into reciprocating and rotary types, depending on the nature of movement of the pressure-producing members. Each of these major classifications may be further subdivided into several specific types of commercial importance, as indicated in Figure 2.

Definitions of the terms employed in Figures 1 and 2, where they are not self-evident, and illustrations and further information on classifications shown are contained in the appropriate sections of this book.

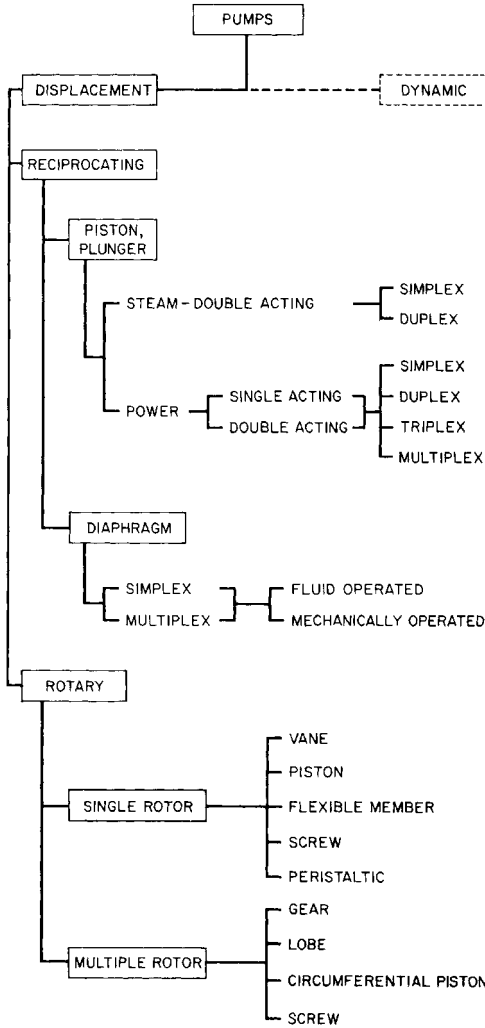


FIGURE 2 Classification of displacement pumps

**OPTIMUM GEOMETRY VERSUS SPECIFIC SPEED**

Optimum geometry of pump rotors is primarily influenced by the specific speed  $N_s$  or  $\Omega_s$ , defined as shown in Figure 3. This parameter is one of the dimensionless groups that emerges from an analysis of the complete physical equation for pump performance. In this equation, performance quantities such as efficiency  $\eta$  and head  $\Delta H$  (or just  $H$ ) are stated to be functions of the volume flow rate  $Q$ , rotative speed  $N$  or angular speed  $\Omega$ , rotor diameter  $D$  or radius  $r$ , viscosity,  $NPSHA$ , and a few quantities that have lesser influence. For low viscosity (high Reynolds number) and  $NPSHA$  that exceeds what the pump requires (namely  $NPSHR$ ), the performance in terms of the head coefficient  $\psi = g\Delta H/(\Omega^2 r^2)$  is influenced only by the flow coefficient or "specific flow"  $Q_s = Q/(\Omega r^3)$ . Now, if one divides  $Q_s^{1/2}$  by  $\psi^{3/4}$ , the rotor



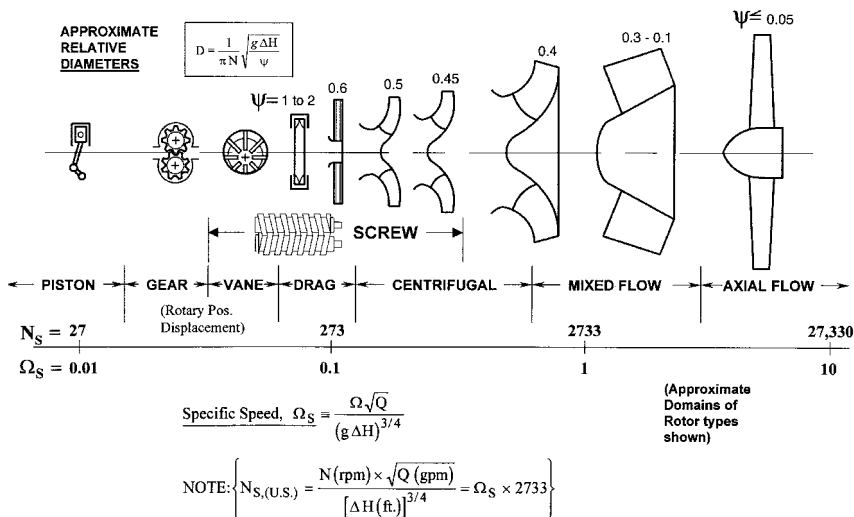


FIGURE 3 Optimum geometry as a function of BEP specific speed (for single stage rotors).

radius  $r (= D/2)$  drops out (which is convenient because we don't usually know it ahead of time), and we get the universal specific speed  $\Omega_s$  as the major dependent variable—in terms of which the hydraulic design is optimized for maximum efficiency, as shown in Figure 3.

This optimum geometry carries with it an associated unique value of the head coefficient  $\psi$ , thereby effectively sizing the rotor. For “rotodynamic” or impeller pumps, imagining speed  $N$  and head  $\Delta H$  to be constant over the  $N_s$ -range shown yields increasing optimum impeller diameter as shown. This size progression shows that the optimum head coefficient  $\psi$  decreases with increasing specific speed.

Outside the  $N_s$  range shown in Figure 3 for each type of rotor, the efficiency becomes unsatisfactory in comparison to that achievable with the configuration shown for this  $N_s$ . Rotary positive displacement machines such as vane pumps, gear pumps, and a variety of screw pump configurations are more appropriate for the lower values of  $N_s$ , the lowest  $N_s$ -values requiring reciprocating (piston or plunger) positive displacement pumps.

Regarding units for these relationships, the rotative speed  $N$  is in revolutions per second (rps) unless stated to be in rpm because the quantity of  $g\Delta H$  usually has the units of length squared per second squared. The diameter  $D$  has the same length unit as the head; for example, in the rotor size equation, head in feet would imply diameter in feet. The universal specific speed  $\Omega_s$  has the same value for any combination of consistent units, and similarly shaped turbine and compressor wheels have similar values of  $\Omega_s$ —making it truly “universal.” Note that for the unit of time of seconds,  $\Omega$  is given as radians per second [=  $N(\text{rpm}) \times \pi/30$ ], where radians are unitless.

### SELECTION OF PUMPS

Given the variety of pumps that is evident from the foregoing system of classification, it is conceivable that an inexperienced person might well become somewhat bewildered in trying to determine the particular type to use in meeting most effectively the requirements for a given installation. Recognizing this, the editors have incorporated in Chapter 11, “Selecting and Purchasing Pumps,” a guide that provides the reader with reasonable familiarity regarding the details that must be established by or on behalf of the user in order to assure an adequate match between system and pump.

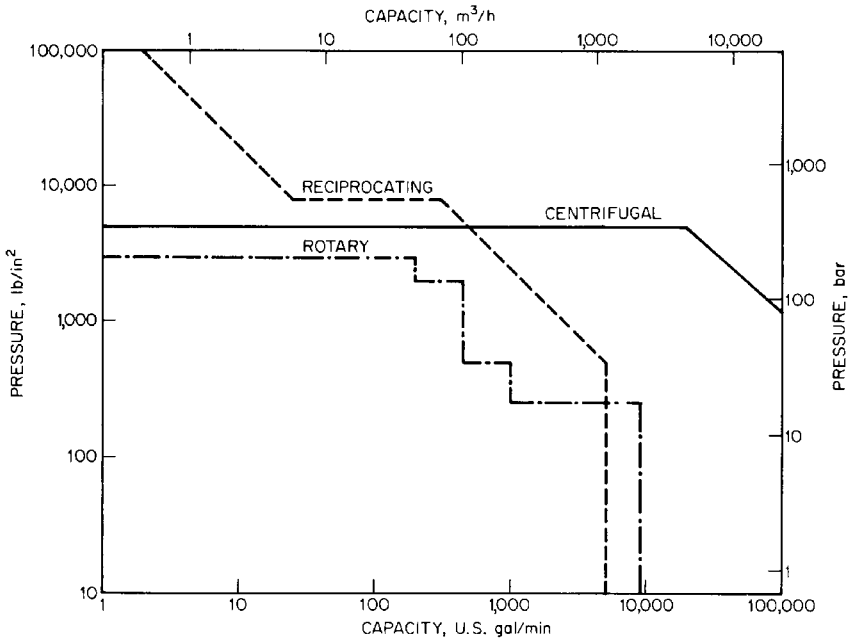


FIGURE 4 Approximate upper limit of pressure and capacity by pump class

Supplementing the information contained in Chapter 11, the sections on centrifugal, rotary, and reciprocating pumps also provide valuable insights into the capabilities and limitations of each of these classes. None of these, however, provide a concise comparison between the various types, and Figure 4 has been included here to do just that, at least for the basic criteria of pressure and capacity.

The lines plotted in Figure 4 for each of the three pump classes represent the upper limits of pressure and capacity currently available commercially throughout the world. At or close to the limits shown, only a few sources may be available, and pumps may well be specially engineered to meet performance requirements. At lower values of pressure and capacity, well within the envelopes of coverage, pumps may be available from dozens of sources as pre-engineered, or standard, products. Note also that reciprocating pumps run off the pressure scale, whereas centrifugals run off the capacity scale. For the former, some highly specialized units are obtainable at least up to 150,000 lb/in<sup>2</sup> (10,350 bar)<sup>1</sup> and perhaps slightly higher. For the latter, custom-engineered pumps would probably be available up to about 3,000,000 U.S. gal/min (680,000 m<sup>3</sup>/h), at least for pressures below 10 lb/in<sup>2</sup> (0.69 bar).

Given that the liquid can be handled by any of the three basic types and given conditions within the coverage areas of all three, the most economic order of consideration for a given set of conditions would generally be centrifugal, rotary, and reciprocating, in that order. In many cases, however, either the liquid may not be suitable for all three or other considerations—such as self-priming or air-handling capabilities, abrasion resistance, control requirements, or variations in flow—may preclude the use of certain pumps and limit freedom of choice. Nevertheless, it is hoped that the information in Figure 4 will be a useful adjunct to that contained elsewhere in this volume.

<sup>1</sup>1 bar = 10<sup>5</sup> Pa. For a discussion of bar, see "SI Units—A Commentary" in the front matter.

C • H • A • P • T • E • R • 2

# **CENTRIFUGAL PUMPS**

---

# SECTION 2.1

---

# CENTRIFUGAL PUMP THEORY

---

PAUL COOPER

## ***INTRODUCTION***

---

A centrifugal pump is a rotating machine in which flow and pressure are generated dynamically. The inlet is not walled off from the outlet as is the case with positive displacement pumps, whether they are reciprocating or rotary in configuration. Rather, a centrifugal pump delivers useful energy to the fluid or “pumpage” largely through velocity changes that occur as this fluid flows through the impeller and the associated fixed passageways of the pump; that is, it is a “rotodynamic” pump. All impeller pumps are rotodynamic, including those with radial-flow, mixed-flow, and axial-flow impellers: the term “centrifugal pump” tends to encompass all rotodynamic pumps.

Although the actual flow patterns within a centrifugal pump are three-dimensional and unsteady in varying degrees, it is fairly easy, on a one-dimensional, steady-flow basis, to make the connection between the basic energy transfer and performance relationships and the geometry or what is commonly termed the “hydraulic design” (more properly the “fluid dynamical design”) of impellers and stators or stationary passageways of these machines.

In fact, disciplined one-dimensional thinking and analysis enables one to deduce pump operational characteristics (for example, power and head versus flow rate) at both the optimum or design conditions and off-design conditions. This enables the designer and the user to judge whether a pump and the fluid system in which it is installed will operate smoothly or with instabilities. The user should then be able to understand the offerings of a pump manufacturer, and the designer should be able to provide a machine that optimally fits the user’s requirements.

The complexities of the flow in a centrifugal pump command attention when the energy level or power input for a given size becomes relatively large. Fluid phenomena such as recirculation, cavitation, and pressure pulsations become important; “hydraulic” and mechanical interactions—involving stress, vibration, rotor dynamics, and the associated design approaches, as well as the materials used—become critical; and operational limits must be understood and respected.

## NOMENCLATURE

NOTE: The units for each quantity defined are as stated in this nomenclature, unless otherwise specifically stated in the text, equations, figures, or tables.

$A$  = area, in<sup>2</sup> (mm).

$a$  = constant of the diffuser or volute configuration in Pfleiderer’s slip relation.

$a$  = radius of impeller disk, ft (m), =  $r_{1,2}$ .

$A_p$  = area of flow passage normal to the flow direction, ft<sup>2</sup> (m<sup>2</sup>).

$b$  = width of an impeller or other bladed passage in the meridional plane, ft (m).

NOTE: When dealing with radial thrust,  $b_2$  includes also the thickness of the shrouds.

$C_p$  = specific heat of liquid being pumped, Btu/(lbm-degF); [kcal/(kg-degC)].

$c$  or  $V$  = absolute velocity, ft/sec (m/s).

$D$  = diameter; unless otherwise subscripted = impeller exit diameter, ft (m).

$d$  = diameter, ft (m).

$D_h$  = hydraulic diameter of flow passage (=  $4A_p/\phi$ ), ft (m).

$F$  = thrust force, lbf ( $N$ ).

$g$  = acceleration due to gravity, = 32.174 ft/sec<sup>2</sup> (9.80665 m/s<sup>2</sup>) at earth sea level.

$g_o$  = constant in Newton’s Second Law, = 32.174 (lbm-ft)/(lbf-sec<sup>2</sup>). (There is no SI equivalent; use the dimensionless constant 1 in place of  $g_o$  in SI computations.)

$\{g_p\}$  = set of fluid properties associated with gas-handling phenomena

$H$  = head of liquid column, ft (m) (Eq. 3); can also have the same meaning as the change in head  $\Delta H$  (that is, the same meaning as “pump head”).

$\Delta H$  = change in head across pump or pump stage, also called the “pump head” or “total dynamic head” ft (m).

$\Delta H$  = the small reduction in pump head (usually 3%) in testing for NPSHR, ft (m).

$H_e = H_{i,\infty}$  = the ideal head for an infinite number of blades that produce no blockage.

$H_i$  = ideal head [=  $H + \Sigma(H_L)$ ], ft (m) (Eq. 15b); sometimes called the “input head.”

$H_L$  = head loss, ft (m).

$\Sigma H_L$  = all losses in the main flow passages from pump inlet to pump outlet, ft (m).

$h$  = static enthalpy in Btu/lbm times  $g_o J$ , ft<sup>2</sup>/sec<sup>2</sup>; (or in kcal/kg times  $J$ , m<sup>2</sup>/s<sup>2</sup> =  $J/\text{kg}$ ).

$h_{se}$  or  $NPSH$  = net positive suction head, ft (m).

$ID$  = inner diameter.

$J$  = the mechanical equivalent of heat, 778 ft-lbf/Btu  
(4184 N-m/kcal).

$\ell$  = blade, vane, or passage arc length, ft (m).

$M$  or  $T$  = torque, lbf-ft (N-m).

$m$  = distance in streamwise direction in meridional plane (Figure 14), in or ft (m).

$\dot{m}$  = mass flow rate, lbf-sec/ft (kg/s), =  $\rho Q$ .

$MCSF$  or  $Q_{\min}$  = minimum continuous stable flow, ft<sup>3</sup>/sec (m<sup>3</sup>/s).

$N$  or  $n$  = rotative speed of the impeller, rpm.

$NPSH$  or  $h_{se}$  = net positive suction head, ft (m).

$NPSHA$  or  $NPSH_A$  = available  $NPSH$ .

$NPSHR$  or  $NPSH_R$  = required  $NPSH$  to prevent significant loss (> 3%) of pump  $\Delta p$  or to protect the pump against cavitation damage, whichever is greater.

$NPSH_{3\%}$  or  $NPSH_{3\%}$  = required  $NPSH$  to prevent significant loss (> 3%) of pump  $\Delta p$ ; this is the "performance  $NPSH$ " defined in Section 2.3.1.

$n_b$  or  $Z_i$  = number of impeller blades.

$n_q$  = specific speed in rpm, m<sup>3</sup>/s,  $m$  units (Eq. 38b) =  $N_g/51.64$  (Eq. 39c).

$n_v$  or  $Z_d$  = number of vanes in diffuser or stator.

$N_s$  or  $N_{s(US)}$  or  $n_s$  = specific speed in rpm, gpm, ft units (Eq. 38a).

$N_{ss}$  or  $S$  = suction specific speed in rpm, gpm, ft units (Eq. 42).

$OD$  = outer diameter.

$P$  = total pressure, lbf/ft<sup>2</sup> (Pa).

$p$  = pressure, lbf/ft<sup>2</sup> [Pa (=N/m<sup>2</sup>)] (= "static pressure").

$\Delta p$  = pressure rise, lbf/ft<sup>2</sup> (Pa).

$p_L$  = pressure loss, lbf/ft<sup>2</sup> (Pa).

$p_{L,i}$  = impeller pressure loss from its inlet to the point of interest, lbf/ft<sup>2</sup> (Pa).

$p_{L,i+in}$  = pressure loss  $p_{L,i}$  in impeller plus pressure loss in inlet passage, lbf/ft<sup>2</sup> (Pa).

$\Sigma p_L$  = all losses in the main flow passages from pump inlet to pump outlet, lbf/ft<sup>2</sup> (Pa).

$p_v$  or  $p_{vp}$  = vapor pressure of liquid being pumped, lbf/ft<sup>2</sup> (Pa).

$P_I$  = power delivered to all fluid flowing through the impeller, ft-lbf/sec (kW).

$P_S$  = shaft power, ft-lbf/sec (kW).

$\phi$  = perimeter of flow passage cross section normal to the flow direction, ft (m).

$Q$  = volume flow rate or, more conveniently, "flow rate" or "capacity," ft<sup>3</sup>/sec (m<sup>3</sup>/s).

$Q_{DR}$  = flow rate below which discharge recirculation exists, ft<sup>3</sup>/sec (m<sup>3</sup>/s).

$Q_L$  = leakage from impeller exit to inlet, ft<sup>3</sup>/sec (m<sup>3</sup>/s).

$Q_{\min}$  or  $MCSF$  = minimum continuous stable flow rate, ft<sup>3</sup>/sec (m<sup>3</sup>/s).

$Q_R$  = flow rate below which recirculation exists, ft<sup>3</sup>/sec (m<sup>3</sup>/s).

$Q_{SR}$  = flow rate below which suction recirculation exists,  $\text{ft}^3/\text{sec}$  ( $\text{m}^3/\text{s}$ ).

Q3D (quasi-3D) = quasi-three dimensional.

$R$  = radius of curvature of meridional streamline, ft (m) (Figures 13, 14, and 25).

$r$  = radial distance from axis of rotation, ft (m).

$r_b$  = radial distance from axis of rotation to center of circle defining impeller passage width, ft (m) (Figures 13 and 25).

$r_e$  = maximum value of  $r$  within the "eye plane." (Figures 13 and 25).

$s$  = width of gap between impeller disk and adjacent casing wall, ft (m).

$S = N_{ss}$ , suction specific speed in rpm, gpm, ft units (Eq. 42).

sp. gr. = specific gravity, namely, the ratio of liquid density to that of water at 60°F (15.6°C).

{S} = set of flow properties associated with solids in the pumpage

$T$  = axial thrust, lbf (N).

$T$  or  $\mathbf{T}$  or  $M$  = torque, lbf-ft ( $N\cdot m$ ).

$T$  = temperature, °F or °R (°C or °K).

$\Delta T_c$  = temperature rise due to compression, °F (°C).

$t$  = time, sec (s).

$t$  = blade or vane thickness, ft (m).

$u$  = internal energy in Btu/lbm multiplied by  $g_c J$ ,  $\text{ft}^2/\text{sec}^2$ ; (or in kcal/kg times  $J$ ,  $\text{m}^2/\text{s}^2$ ).

$U$  = tangential speed  $\Omega r$  of the point on the impeller at radius  $r$ , ft/sec (m/s).

$U_e$  = the value of  $U$  at the maximum radial location  $r_e$  within the "eye plane."

$\mathbf{V}$  = volume,  $\text{ft}^3$  ( $\text{m}^3$ ).

$V$  or  $c$  = absolute velocity of fluid, ft/sec (m/s).

$V_e$  = the average value of the meridional velocity component  $V_m$  in the eye (=  $Q/A_e$ ), ft/sec (m/s).

$V_s$  = slip velocity (Figure 15), ft/sec (m/s).

$W$  or  $w$  = velocity of fluid relative to rotating impeller, ft/sec (m/s).

$W_g$  = the one-dimensional value of  $W$  that would exist if there were no slip.

$w_1$  = throat width (Figure 21), ft (m).

$y$  = transformed distance along blade from trailing edge (Figure 19), in or ft (m).

$z$  = axial distance in polar coordinate system, ft (m).

$Z$  or  $Z_e$  = elevation coordinate, ft (m).

$Z_d$  or  $n_v$  = number of vanes in diffuser or stator.

$Z_i$  or  $n_b$  = number of impeller blades.

$\alpha$  = angle of the absolute velocity vector from the circumferential direction.

$\beta$  = angle of the relative velocity vector or impeller blade in the plane of the velocity diagram (as seen, for example, in Figure 3) from the circumferential (tangential) direction.

- $\gamma$  = fluid weight density, lbf/ft<sup>3</sup> (N/m<sup>3</sup>) =  $\rho g$ . (1N = 1 kg·m/s<sup>2</sup>).
- $\delta$  = clearance, ft (m)
- $\delta^*$  = displacement thickness of the boundary layer, ft (m).
- $\delta_0^*$  = displacement thickness of the zero-pressure-gradient boundary layer, ft (m), ( $\approx 0.002 \times \ell$  for turbulent boundary layers at  $\nu = 1$  cs in typical centrifugal pumps).
- $\varepsilon$  = absolute roughness height, ft (m)
- $\varepsilon_2$  = fraction of impeller discharge meridional area (that is, the area normal to the velocity component  $V_{m,2}$ ) that is *not* blocked by the thickness of the blades and the boundary layer displacement thickness on blades and on hub and shroud surfaces.
- $\varepsilon_{2,b}$  = fraction of the circumference at the exit of the impeller that is *not* blocked by the thickness of the blades and boundary layer displacement thickness on blades. (See computation in Table 4.)
- $\eta$  =  $\eta_p$  = pump efficiency; or a component efficiency (different subscript, Eqs. 8–11).
- $\theta$  = rotational polar coordinate or central angle about the impeller axis, radians.

NOTE: In a polar-coordinate description of impeller blades or stationary vanes,  $\theta$  becomes the construction angle and is usually regarded as positive in the direction of the blade development from inlet to exit of the impeller or other blade row.

- $\mu$  = slip factor =  $V_s/U_2$  ( $= 1 - h_0$ , where  $h_0$  is the slip factor as defined by Busemann<sup>18</sup>.)
- $\mu$  = absolute viscosity, lbf·sec/ft<sup>2</sup> (Pa·s or N·s/m<sup>2</sup>); often quoted in centipoises, abbreviated to “cp” (1 cp = 0.001 Pa·s). [ $\mu$  in cp] = sp. gr.  $\times$  ( $\nu$  in cs).]
- $\nu$  = kinematic viscosity ( $= \mu/\rho$ ), ft<sup>2</sup>/sec (m<sup>2</sup>/s); often quoted in centistokes, abbreviated to “cs” (1 cs = 1 mm<sup>2</sup>/s). [ $\nu$  in cs] = ( $\mu$  in cp)/sp. gr.
- $\rho$  = fluid mass density, lbf·sec<sup>2</sup>/ft<sup>4</sup> (kg/m<sup>3</sup>), =  $\gamma/g$ .
- $\sigma$  = solidity (Eq. 53).
- $\sigma$  = Thoma’s cavitation parameter =  $h_{s0}/H$ .
- T** or **T** or **M** = torque, lbf·ft (N·m).
- $\phi$  = flow coefficient.
- $\phi_e = V_e/U_e$  = impeller inlet or eye flow coefficient.
- $\phi_i$  (or  $\phi_{i,2}$ ) = impeller exit flow coefficient =  $V_{m,2}/U_2$  (Figure 12).
- $\psi$  = head coefficient (Figure 12); stream function (Figure 14).
- $\psi_i$  = ideal head coefficient [ $= \psi_{i,2} = V_{\theta,2}/U_2$  for zero inlet swirl ( $V_{\theta,1} = 0$ )].
- $\psi_{i,2} = V_{\theta,2}/U_2$  [ $= \psi_i$  for zero inlet swirl ( $V_{\theta,1} = 0$ )].
- $\Omega$  = angular speed of the impeller in radians per second (1/s) =  $N\pi/30$ .
- $\Omega_s$  = universal specific speed (unitless) (Eq. 37) =  $N_s/2733$  (Eq. 38a) =  $n_q/52.92$  (Eq. 38b).
- $\Omega_{ss}$  = universal suction specific speed (unitless) (Eq. 41) =  $N_{ss}/2733$  (Eq. 42).
- {2-ph} = set of fluid properties associated with vaporization



**Subscripts**

- $b$  = impeller blade.
- $D$  = drag due to disk friction, bearings, and seals.
- DF = disk friction.
- $d$  = discharge flange or exit (ex) of the pump.
- $e$  = at the “eye” of the impeller. The “eye” is the throat (minimum-diameter point) at the entrance into the impeller and is the area defined by the “eye plane,” which is normal to the axis of rotation. “ $e$ ” can refer more specifically to the shroud or maximum-diameter point within the eye, as with  $r_e$  (Figure 13) or  $U_e$ . The inlet tips of the impeller blades are generally at or near this location.
- ex = exit of diffuser or the discharge flange or port of the pump ( $d$ ).
- $f$  = the direction of the flow.
- $h$  = hub.
- $i$  = inner limit of region or gap (Tables 4 and 5)
- $i$  (or ideal) = ideal.
- $i$  (or imp) = impeller.
- in (or  $s$ ) = pump inlet flange or port.
  - $I/L$  = inlet passage; that is, the passage from the pump inlet flange or port to the impeller.
  - $I$  = input to fluid.
  - $L$  = losses.
  - $m$  = “mechanical” (pertaining to efficiency, Eq. 9).
  - $m$  = component of velocity in the meridional plane (that is, the axial-radial plane containing the axis of rotation).
- mean = the 50% or rms meridional streamline.
  - $n$  = normal or BEP value.
  - $o$  = outer limit of region or gap (Tables 4 and 5).
- out = pump outlet flange or port.
  - $p$  = pressure side of blade or passage.
  - $R$  = value of  $r$  at the impeller ring clearance.
  - $S$  = shaft.
- $s$  (or in) = suction flange or inlet of the pump.
  - SE = shockless entry (that is, inlet velocity vector aligned with blade camber line).
  - $s/o$  = shut-off or zero flow rate  $Q$ .
  - $r$  = in the radial direction.
- rms = the 50% or mean meridional streamline.
  - $s$  = shaft.
  - $s$  = suction side of blade or passage.
  - $s$  = same meaning as  $sh$  and  $t$ .
  - $sh$  = shroud (also at the eye plane at inlet—and in general “ $t$ ” at outlet).
- stg = stage.
- $T$  = entry throat of volute or diffuser.

- $t$  = the tip or maximum radial position of the impeller blades at inlet or outlet (same meaning as  $s$  and  $sh$ ).
- $t$  = tongue or cutwater.
- $u$  (see  $\theta$ , below).
- $v$  = volumetric (pertaining to efficiency, Eq. 11).
- $v$  = volute.
- $z$  = in the axial direction.
- $\theta$  or  $u$  = component of velocity in the circumferential direction (that is, the tangential direction in the polar view that is perpendicular to the axis of rotation).
- 1 = impeller inlet at the blade leading edge—at the mean unless further defined.
- 2 = impeller outlet at the blade trailing edge—at the mean unless further defined.
- 3 = volute base circle or entrance to diffuser.
- $\infty$  = for an infinite number of blades that also produce zero blockage of the flow.

### Superscripts

- = average value

## ENERGY TRANSFER

---

Hydraulics or fluid dynamics has the primary influence on the geometry of a rotodynamic pump stage—of all the engineering disciplines involved in the design of the machine. It is basic to the energy transfer or pumping process. Staging is also influenced by the other disciplines, especially in high-energy pumps. The basic energy transfer relationships need to be thoroughly understood to achieve a credible design and to understand the operation of these machines. Action of the mechanical input shaft power to effect an increase in the energy of the pumpage is governed by the first law of thermodynamics. Realization of that energy in terms of pump pressure rise or head involves losses and the second law of thermodynamics.

**The First Law of Thermodynamics** Fluid flow, whether liquid or gas, through a centrifugal pump is essentially adiabatic, heat transfer being negligible in comparison to the other forms of energy involved in the energy transfer process. (Yet, even if the process were not adiabatic, the density of a liquid is only weakly dependent on temperature.) Further, while the delivery of energy to fluid by rotating blades is inherently unsteady (varying pressure from blade to blade as viewed in an absolute reference frame), the flow across the boundaries of a control volume surrounding the pump is essentially steady, and the first law of thermodynamics for the pump can be expressed in the form of the adiabatic steady-flow energy equation (Eq. 1) as follows:

$$P_s = \dot{m} \left[ \left( h + \frac{V^2}{2} + gZ_e \right)_{\text{out}} - \left( h + \frac{V^2}{2} + gZ_e \right)_{\text{in}} \right]$$

where

$$h = u + \frac{p}{\rho} \quad (1)$$

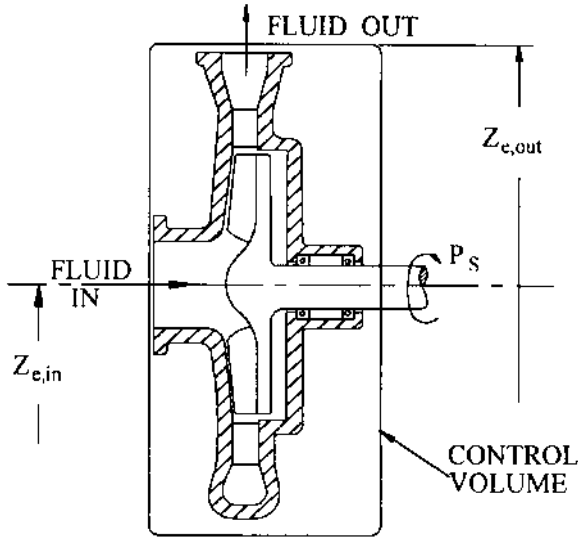


FIGURE 1 Energy transfer in a centrifugal pump

Here, shaft power  $P_s$  is transformed into fluid power, which is the mass flow rate  $\dot{m}$  times the change in the total enthalpy (which includes static enthalpy, velocity energy per unit mass, and potential energy due to elevation in a gravitational field that produces acceleration at rate  $g$ ) from inlet to outlet of the control volume (Figure 1).

When dealing with essentially incompressible liquids, the shaft power is commonly expressed in terms of “head” and mass flow rate, as in Eq. 2:

$$\frac{P_s}{\dot{m}} = g\Delta H + \Delta u \tag{2}$$

where

$$H = \frac{p}{\rho g} + \frac{V^2}{2g} + Z_e \tag{3}$$

The change in  $H$  is called the “head”  $\Delta H$  of the pump; and, because  $H$  (Eq. 3) includes the velocity head  $V^2/2g$  and the elevation head  $Z_e$  at the point of interest,  $\Delta H$  is often called the “total dynamic head.”  $\Delta H$  is often abbreviated to simply “ $H$ ” and is the increase in height of a column of liquid that the pump would create if the static pressure head  $p/\rho g$  and the velocity head  $V^2/2g$  were converted without loss into elevation head  $Z_e$  at their respective locations at the inlet to and outlet from the control volume; that is, both upstream and downstream of the pump.

**The Second Law of Thermodynamics: Losses and Efficiency** As can be seen from Eq. 2, not all of the mechanical input energy per unit mass (that is, the shaft power per unit of mass flow rate) ends up as useful pump output energy per unit mass  $g\Delta H$ . Rather, losses produce an internal energy increase  $\Delta u$  (accompanied by a temperature increase) in addition to that due to any heat transfer into the control volume. This fact is due to the second law of thermodynamics and is expressed for pumps in Eq 4:

$$g\Delta H < \frac{P_s}{\dot{m}} \quad \text{or} \quad \eta < 1 \tag{4}$$

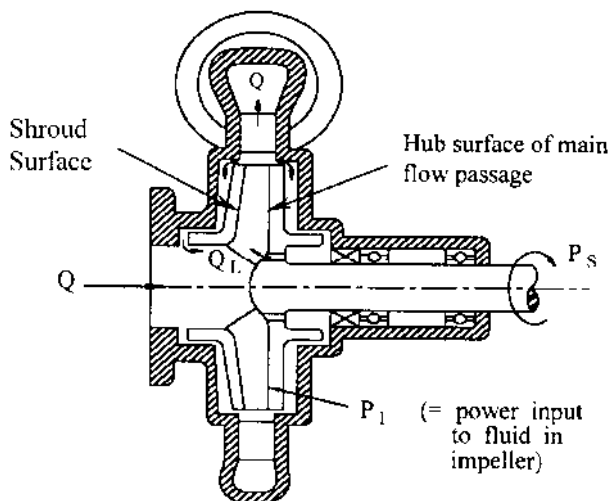


FIGURE 2 Determining component efficiencies. (This is a meridional view.)

where

$$\dot{m} = \rho Q$$

The losses in the pump are quantified by the overall efficiency  $\eta$ , which must be less than unity and is expressed in Eq. 5:

$$\eta = \frac{g\Delta H\dot{m}}{P_s} = \text{Overall Pump Efficiency} \quad (5)$$

It should be pointed out here that real liquids undergo some compression—which is accompanied by a reversible increase in the temperature  $\Delta T_c$  of the liquid—called the “heat of compression.” This portion of the actual total temperature rise  $\Delta T$  is in addition to that arising from losses and must therefore be taken into account when determining efficiency from measurements of the temperature rise of the pumpage.<sup>1</sup> See the discussion on this subject in Section 2.3.1.

To pinpoint the losses, it is convenient to deal with them in terms of “component efficiencies.” For the typical shrouded- or closed-impeller pump shown in Figure 2, Eq. 5 can be rewritten as follows:

$$\eta = \frac{P_I}{P_s} \times \frac{g\Delta H(\dot{m} + \dot{m}_L)}{P_I} \times \frac{\dot{m}}{\dot{m} + \dot{m}_L} \quad (6)$$

Noting that

$$P_i = g\Delta H_i(\dot{m} + \dot{m}_L) \quad (7)$$

and

$$\dot{m} = \rho Q$$

$$H_i = \text{Ideal Head}$$

one may rewrite Eq. 6 as follows:

$$\eta = \frac{P_I}{P_S} \times \frac{\Delta H}{\Delta H_i} \times \frac{Q}{Q + Q_L} = \eta_m \times \eta_{HY} \times \eta_v \quad (8)$$

where

$$\left. \begin{array}{l} \text{“Mechanical”} \\ \text{Efficiency} \end{array} \right\} \eta_m = \frac{P_I}{P_S} = \frac{P_S - P_D}{P_S} \quad (9)$$

$$\left. \begin{array}{l} \text{Hydraulic} \\ \text{Efficiency} \end{array} \right\} \eta_{HY} = \frac{\Delta H}{\Delta H_i} = \frac{\Delta H_i - \sum H_L}{\Delta H_i} \quad (10)$$

$$\left. \begin{array}{l} \text{Volumetric} \\ \text{Efficiency} \end{array} \right\} \eta_v = \frac{Q}{Q + Q_L} \quad (11)$$

Approximate formulas for the three component efficiencies of Eq. 8 will be given further on. Their product yields the overall pump efficiency as defined in Eq. 5, and reflects the following division of the pump losses:

- a. External drags on the rotating element due to i) bearings, ii) seals, and iii) fluid friction on the outside surfaces of the impeller shrouds—called “disk friction”; the total being  $P_D = P_S - P_I$ . Generally, the major component of  $P_D$  is the disk friction, and the “mechanical efficiency” is that portion of the shaft power that is delivered to the fluid flowing through the impeller passages.
- b. Hydraulic losses in the main flow passages of the pump; namely, inlet branch, impeller, diffuser or volute, return passages in multistage pumps, and outlet branch. The energy loss per unit mass is  $g\sum H_L = g(H_i - \Delta H)$ , the ratio of output head  $\Delta H$  to the input head  $H_i$  being the hydraulic efficiency. This is the major focus of the designer for typical centrifugal pump geometries (which are associated with normal “specific speeds”—to be defined later). The other two component efficiencies are then quite high and of relatively little consequence.
- c. External leakages totaling  $Q_L$  leaking past the impeller and back into the inlet eye. This leakage has received its share of the full amount of power  $P_I = \rho g \Delta H_i (Q + Q_L)$  delivered to all the fluid ( $Q + Q_L$ ) passing through the impeller. This leakage power is  $P_L = \rho g \Delta H_i Q_L$ , which is lost as this fluid leaks back to the impeller inlet. The remaining fluid input power is thus  $(P_I - P_L) = \rho g \Delta H_i Q$ , the ratio of this power to the total ( $P_I$ ) being the volumetric efficiency.

There are exceptions to this convenient model for dividing up pump losses. The main exception is that if the pump has an open impeller, that is, one without either or both shrouds, that portion of the total leakage  $Q_L$  disappears. The leakage now occurs across the blade tips and affects the main flow passage hydraulic losses. The volumetric efficiency is now higher, but the hydraulic efficiency is lower. In that case disk friction is still present, as the impeller still has to drag fluid along the adjacent stationary wall(s). Another exception—for closed impellers—is that disk friction is fundamentally an inefficient pumping action, the fluid being flung radially outward<sup>2</sup>; and this can result in a slight increase in pump head if the fluid on the outside of an impeller shroud or disk is pumped into the main flow downstream of the impeller.

## VELOCITY DIAGRAMS AND HEAD GENERATION

The mechanism of the transfer of shaft torque (or power) to the fluid flowing within the impeller is fundamentally dynamic; that is, it is connected with changes in fluid velocity. This requires the introduction of Newton’s second law, which when combined with the first

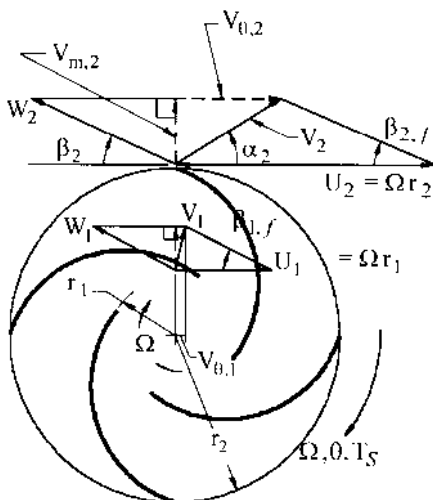


FIGURE 3 Impeller velocity diagrams (1 = inlet; 2 = outlet)

law of thermodynamics, yields Euler's Pump Equation. Fluid velocities at inlet and exit of the impeller are fundamental to this development. Fluid flowing along the blades of an impeller rotating at angular velocity  $\Omega$  and viewed in the rotating reference frame of that impeller has relative velocity  $W$ . Vectorially adding  $W$  to impeller blade speed  $U = \Omega r$  yields the absolute velocity  $V$ , as shown in the velocity diagrams of Figure 3.

**Newton's Second Law for Moments of Forces and Euler's Pump Equation** Relating impeller torque  $\mathbf{T}$  to fluid angular momentum per unit mass  $rV_\theta$  is the convenient way of applying Newton's second law to centrifugal pumps. This is stated as follows for the control volume  $\mathbf{V}$  that contains the pump impeller (Eq. 12):

$$\Sigma \mathbf{T} = \iint \mathbf{V} (\partial(\rho r V_\theta) / \partial t) / d\mathbf{V} + \iint \rho r V_\theta dQ \quad (12)$$

where  $\Sigma \mathbf{T} = \mathbf{T}_s - \mathbf{T}_D$  is the summation of torques acting on the impeller; namely, the net torque  $\mathbf{T}_s$  acting on the fluid flowing through it. The volume integral (first term on the right side) of Eq. 12 is the unsteady term, which is zero for steady operation. It comes into play during changing or transient conditions, such as start up and shutdown; that is, when the angular momentum per unit volume  $\rho r V_\theta$  is changing with time within the impeller volume  $\mathbf{V}$ .

The surface integral (second term on the right hand side) of Eq. 12 is the one that pump designers and users are mainly concerned with. Its integration over the exterior surface of the control volume  $\mathbf{V}$  is effectively accomplished for most impellers by combining one-dimensional results from inlet to outlet on each of several stream surfaces—imagined to be nested surfaces of revolution bounded by the hub and shroud stream surfaces (indicated in Figure 2). Insight into the power of this term can be gained by taking the mean value of the integrand in terms of the velocities on a representative stream surface; that is, essentially the surface of revolution lying at an appropriate mean location between hub and shroud. Each of the two velocity diagrams of Figure 3 lies in a plane tangent to this mean stream surface. For flow through an impeller, the torque delivered to the fluid is therefore given by the following relationship involving these average quantities:

$$\mathbf{T}_I = (\dot{m} + \dot{m}_L) \times (r_2 V_{\theta,2} - r_1 V_{\theta,1}) \quad (13)$$

or  $\times \Omega$ :

$$P_I = (\dot{m} + \dot{m}_L) \times (U_2 V_{\theta,2} - U_1 V_{\theta,1}) \quad (14)$$

Eq. 13 says that the torque is equal to the mass flow rate times the change of angular momentum per unit mass  $\Delta(rV_\theta)$ . This becomes the “power” statement of Eq. 14 when both sides are multiplied by  $\Omega$ . Following the statement of the second law of thermodynamics in Eq. 4, we now can similarly say that  $g\Delta H$  must be less than the power input to the fluid per unit of mass flow rate, namely  $\Delta(UV_\theta)$  from Eq. 14. So, we now arrive at Euler’s Pump Equation—expressed three different ways as follows:

$$g\Delta H < \Delta(UV_\theta) \quad (15a)$$

$$g\Delta H_i = \Delta(UV_\theta) \quad (15b)$$

or

$$g\Delta H = \eta_{HY}\Delta(UV_\theta) \quad (15c)$$

The inequality (Eq. 15a) is quantified by Eq. 15b, which follows in view of Eq. 7. Eq. 15c then follows from the definition of hydraulic efficiency (Eq. 10). Euler’s Pump Equation makes one of the most profound statements in the field of engineering, because it determines the major geometrical features of the design of a rotodynamic machine. By reversing the inequality in Eq. 15a, the same principle applies to turbines; hence, the more encompassing title, “Euler’s Pump and Turbine Equation.”

So, to design or analyze a pump, one needs to a) obtain the velocity diagrams that will produce the ideal head at the design flow rate and b) determine how the shape of these diagrams affects the hydraulic efficiency  $\eta_{HY}$ , so as to obtain the desired pump stage head. Step (a) for a given pump is a simple one-dimensional exercise that utilizes the principles of continuity and kinematics (Eqs. 16 and 17) to construct the velocity diagrams for a given total impeller volume flow rate  $Q$  and pump rotative speed ( $\Omega$  or  $N$ ):

$$\text{Continuity:} \quad Q = 2\pi r b V_m \quad (16)$$

where  $W = V_m / \sin \beta_f$

$$\text{Kinematics:} \quad V_\theta = U - W \cos \beta_f \quad (17)$$

Step (b) is in essence the evaluation of the hydraulic losses  $\Sigma H_L$  in Eq. 10, which depend mainly on the relative and absolute velocities, the associated flow passage dimensions, and incidence angles. Eq. 15c then gives the head that the pump stage will generate. Performing steps (a) and (b) at several other flow rates at the same speed enables one to develop the pump performance characteristics.

## STATIC PRESSURE GENERATION

---

**The Extended Bernoulli Equation** To estimate the losses, it is convenient first to investigate the static pressure and velocity head portions of the total head. Eq. 15c can be written in terms of the total pressure  $P$ , which equals  $\rho g H$ . Similarly, we may speak of hydraulic losses as losses of static pressure  $\Sigma p_L$ , which equals  $\rho g \Sigma H_L$ ; so

$$P = P_{in} + \rho(UV_\theta - U_1 V_{\theta,1}) - \Sigma p_L \quad (18)$$

where, from Eq. 3, the static, dynamic and potential energy components of the total pressure are brought into evidence:

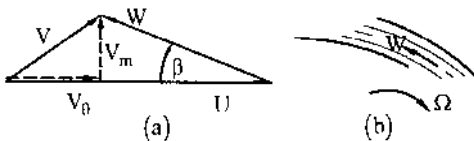


FIGURE 4 Velocity triangle and flow within impeller passageway

$$P = p + \frac{1}{2} \rho V^2 + \rho g Z_e = \rho g H \tag{19}$$

Eq. 18 is the turbomachine form of the “extended Bernoulli equation,” which states that along a streamline the total pressure  $P$ —also known as the Bernoulli constant and defined in Eq. 19—is a) decreased by losses and b) increased by energy addition that occurs along the streamline.

**Centrifugal and Diffusion Effects in Impellers** Changes in potential energy across a pump stage are small; so the static pressure rise is found essentially from subtracting the dynamic (velocity) pressure change from the total pressure change. Within the impeller, the static pressure in turn arises from a) centrifugal and b) passage diffusion effects.

Fluid in the impeller passage of Figure 4b flows from low to high radius  $r$  or blade speed  $U$ , often also experiencing a decrease in passage relative velocity  $W$ . The geometry of the velocity diagram (Figure 4a) leads to the following combination of Eqs. 18 and 19 applied across the impeller:

$$\Delta \left( p + \frac{1}{2} \rho V_m^2 + \frac{1}{2} \rho V_\theta^2 \right) = \Delta [\rho U \times (U - W \cos \beta)] - p_{L,i} - \Delta(\rho g Z_e) \tag{20}$$

and, because  $V_m = W_m$ , this simplifies to the following form of the extended Bernoulli equation, which applies along a streamline from the inlet of the impeller:

$$\underbrace{p - p_1}_{\text{Static Pressure Change}} = \frac{1}{2} \rho \left( \underbrace{U^2 - U_1^2}_{\text{Centrifugal Effect}} + \underbrace{W_1^2 - W^2}_{\text{Passage Diffusion}} \right) - \underbrace{p_{L,i}}_{\text{Losses: Incidence, Friction, Secondary Flow, Tip Leakage, Mixing}} - \rho g(Z_e - z_{e,i}) \tag{21}$$

Here, the  $U$ -increase corresponds to the centrifugal contribution to the static pressure rise, and the  $W$ -decrease to the diffusion contribution. There is no  $U$ -change along an axial streamline in an axial-flow impeller or propeller; so, static pressure rise is due only to diffusion. Radial-flow impellers, on the other hand, often have little or no net  $W$ -change, the centrifugal effect being paramount. [A study of the velocity diagrams of Figure 3 suggests that such impellers possess a high “degree of reaction.” The degree of reaction is defined as that fraction of the total energy addition within the impeller (Eq. 15b) that does *not* include the change in absolute velocity energy,  $\Delta(V^2/2)$ . This fraction is, therefore, the sum



of the static pressure energy change, that due to elevation change, and the energy losses in the impeller, as can be seen from Eqs. 18 and 19.]

**Collector Static Pressure Rise, Inlet Nozzle Drop** A similar form of Eq. 21 applies in the stationary flow elements, where  $W$  is also the absolute velocity  $V$  and blade speed  $U$  is zero. (This would be a more recognizable form of the extended Bernoulli equation, wherein only losses modify the Bernoulli constant.<sup>3</sup>) A further static pressure increase occurs in the stationary collection system downstream of the impeller (with the attendant losses); namely, in the stationary volute or diffuser. This static rise is generally about a third of that in the impeller, and it is due only to diffusion, that is, the decrease in velocity in that passage. To complete the picture, there is often an increase in the comparatively small velocity in the approach passageway or nozzle or suction branch from the pump inlet port or flange to the impeller eye or blade leading edge. This is accompanied by an attendant small pressure drop.

**Internal Static Pressure Distribution** If the fluid enters the pump from a stagnant pool, the total pressure at the impeller eye  $P_1$  will be very nearly the static pressure of the upstream pool (plus the pressure equivalent of the elevation of the pool above the eye). This is one reason why the local static pressure  $p$  within the pump is often referenced to  $P_1$ , as indicated in the following form of Eq. 21:

$$p - P_1 = \frac{1}{2} \rho(U^2 - W^2) - p_{L,i} - \rho g Z_e - \rho U_1 V_{\theta,1} \quad (22)$$

where

$$P_1 = p_1 + \rho \frac{V_1^2}{2} + \rho g Z_{e,1} \quad (23)$$

Figure 5 is an illustration of the internal static pressure development. The difference between  $P_1$  and  $p_1$  is due to the impeller inlet absolute velocity head or dynamic pressure  $\rho V_1^2/2$ , a much larger difference existing at the impeller exit, namely  $\rho V_2^2/2$ . Losses in the collector result in the pump or stage outlet total pressure  $P_{out}$  being less than  $P_2$ , the rise in total pressure  $\Delta P_{pump}$  from port to port being  $P_{out} - P_{in}$ . In the figure,  $P_{in}$  is very nearly the same as  $P_1$ , the inlet passage loss being comparatively small for most pumps.

## NET POSITIVE SUCTION HEAD

Local reduction of the static pressure  $p$  to the vapor pressure  $p_v$  of the liquid causes vaporization of the liquid and cavitation. Internal pressure drops are due to a) impeller inlet velocity head and inlet passage loss and b) blade loading and loss within the impeller. In order to prevent a substantial decrease of impeller pressure rise, the sum of these pressure drops should not exceed the difference between  $P_{in}$  and  $p_v$ , the head equivalent of which is called "net positive suction head" or *NPSH*:

$$\frac{P_{in} - p_v}{\rho g} \equiv NPSH \Rightarrow P_{in} = \rho g NPSH + p_v \quad (24)$$

Insufficient *NPSH* leads to cavitation and loss of pump pressure rise. That is because the impeller can become filled with vapor, in which case the density  $\rho$  of the fluid within the impeller is then reduced by orders of magnitude. This in turn, as can be seen in Eqs. 18–22, results in essentially zero pump pressure rise; that is, total loss of pump performance.

Eq. 24 substituted into Eq. 22 yields the local static pressure above vapor pressure in terms of the *NPSH*:

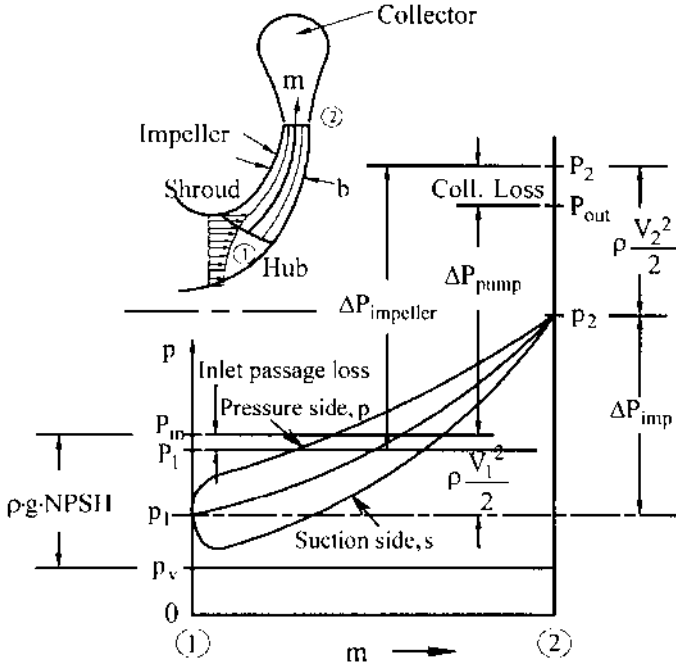
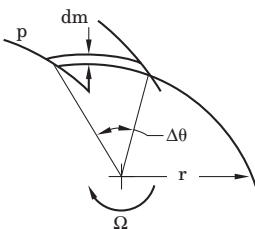


FIGURE 5 Pump stage internal pressure development. Total pressure rise  $\Delta P = \rho g \Delta H$ .

$$p - p_v = \rho g NPSH + \frac{1}{2} \rho (U^2 - W^2) - P_{L,i+1/L} - \rho g Z_e - \rho U_1 V_{\theta,1} \tag{25}$$

This, together with the foregoing pressure drops, which occur in the inlet region of the pump, is illustrated in Figure 5. The figure contains three plots of  $p$  along the representative streamline from 1 to 2,  $m$  being distance along this line in the meridional plane. These plots are for the suction side or trailing face of an impeller blade, the pressure side or driving face, and the average or mid-passage position. The middle or average pressure plot is readily described by Eq. 25 in terms of the local average  $W$ -distribution. The local blade-to-blade static pressure difference  $p_p - p_s$  arises from the torque exerted on a strip of fluid between the blades and approximated here via blade-to-blade average velocity components in Newton's Second Law for Moments of Forces:



$$r(p_p - p_s) b dm = \rho V_m b r \cdot \Delta \theta \cdot d(rV_\theta) \tag{26}$$

$$p_p - p_s = \frac{2\pi}{n_b} \frac{\rho V_m}{\Omega} \frac{d(UV_\theta)}{dm}$$

where, for ease of illustration, the blade-to-blade polar angle difference  $\Delta\theta$  is taken equal to  $2\pi/n_b$ , the actual value of  $\Delta\theta$  being slightly less than this due to the thickness of the blades. Thus, for example, too small a number of blades  $n_b$  results in a larger value of  $p_p - p_s$  and a lower minimum static pressure in the inlet region of the impeller.

The density reduction in a cavitating impeller is difficult to predict analytically; therefore, empirical relationships for acceptable levels of *NPSH* have been developed and will be presented further on, as guidelines for design and performance prediction are developed.

**PERFORMANCE CHARACTERISTIC CURVES**

Velocity diagrams and ideal head-rise vary with flow rate  $Q$  as illustrated in Figure 6 for the typical case of constant rotative speed  $N$  or angular speed  $\Omega$ . Flow patterns in Figure 6b correspond to points on the characteristic curves of Figure 6a. The inlet velocity diagrams (just upstream of the impeller) are shown there for high and low flow rate—with zero swirl being delivered by the inlet passageway to the impeller; that is,  $V_{\theta,1} = 0$ . The outlet velocity diagrams on Figure 6a are found one-dimensionally, the magnitude of the exit relative velocity vector  $W_2$  varying directly with  $Q$  and its direction being nearly tangent to the impeller blade. From these diagrams are found the absolute velocity vector  $V_2$  and its circumferential component  $V_{\theta,2}$ . Because blade speed  $U_2$  is constant, the resulting plot of the ideal head  $\Delta H_i = U_2 V_{\theta,2}/g$  (from Eq. 15b) is a straight line, rising to the point  $U_2^2/g$  at zero- $Q$  or “shut-off head.” This is twice the impeller OD tip speed head  $U_2^2/2g$ . The right-most velocity diagram in Figure 6a has zero  $V_{\theta,2}$ ; however, the maximum or “runout” flow rate happens at lower  $Q$  than this. That is because the actual head  $H$  is less than  $\Delta H_i$  due to losses (as seen in Eq. 10), and  $\Delta H = 0$  at runout—where overall pump efficiency (Eq. 8) is also zero.

This one-dimensional analysis works well in the vicinity of the best efficiency point (b.e.p. or BEP) and at higher  $Q$  because the fluid flows smoothly through the impeller pas-

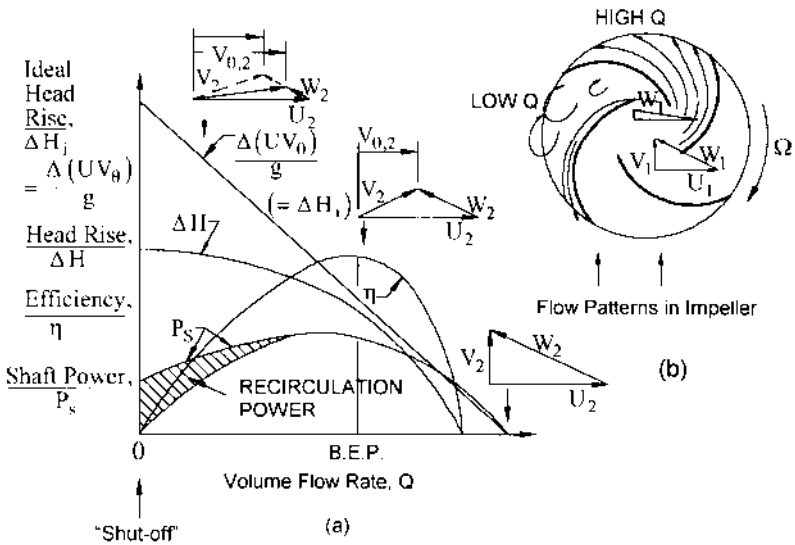


FIGURE 6A and B Characteristic performance curves of a pump stage, related to velocity diagrams

sages as illustrated in Figure 6b for “high  $Q$ .” However, it fails at “low  $Q$ ,” where recirculating flow develops—indicated by a substantial one-dimensional deceleration or reduction in the fluid velocity relative to those passages—that is,  $W_2 \ll W_1$ . This is analogous to a diffuser with side walls that diverge too much: the main fluid stream separates from one or both walls and flows along in a narrow portion of the passage in a jet—the rest of the passage being occupied with eddying fluid that can recirculate out of the impeller inlet and exit. Consequently, the real outlet velocity diagram at low  $Q$  is the one with the dashed lines and the smaller value of  $V_{\theta,2}$ , rather than the solid-lined, one-dimensional diagram superimposed on it. This in turn reduces the ideal head at the low- $Q$  point of the curves.

To complicate matters further at low  $Q$ , one-dimensional application of this “corrected” outlet velocity diagram via Eq. 14 would produce a pump power consumption curve that passes through the origin of Figure 6a. Such a result (assuming negligible external drag power  $P_D$ ), is known not to occur in a real pump. Rather, superimposed on the jet flow pattern just described is recirculating fluid that leaves the impeller, gives up its angular momentum to its surroundings, and re-enters the impeller to be re-energized.

In other words, the one-dimensional simplifications mentioned after Eq. 12 do not hold at low  $Q$ ; rather, there is an added “recirculation power,” which is the  $UV_r$ -change experienced by the recirculating fluid integrated over each element of re-entering mass flow rate<sup>4</sup>. The complexity of this recirculation destroys one’s ability to interpret pump performance under such conditions by means of velocity diagrams. Instead, a transition is made from empirical correlations for head and power at “shutoff” or zero net flow rate to the high- $Q$ , one-dimensional analysis, enabling one to arrive at the complete set of characteristic curves for efficiency, power, and head illustrated in Figure 6a. In fact, impeller pressure-rise at shutoff is very nearly what would be expected due to the centrifugal effect of the fluid rotating as a solid body, namely  $\rho U_2^2/2$ . The recirculating flow patterns seem to be merely superimposed with little effect on impeller pressure-rise. This recirculation, on the other hand, does produce some additional shutoff pressure rise in the collecting and diffusing passages downstream of the impeller.

## SCALING AND SIMILITUDE

When a set of characteristic curves for a given pump stage is known, that machine can be used as a model to satisfy similar conditions of service at higher speed and a different size. Scaling a given geometry to a new size means multiplying every linear dimension of the model by the scale factor, including all clearances and surface roughness elements. The performance of the model is then scaled to correspond to the scaled-up model by requiring similar velocity diagrams (often called “velocity triangles”) and assuming that the influences of fluid viscosity and vaporization are negligible. The proportions associated with Eqs. 27, 29, and 32 illustrate this. The blade velocity  $U$  (Eq. 30) varies directly with rotative speed  $N$  or angular speed  $\Omega$ —and directly with size, as expressed by the radius  $r$ . For the velocity  $V$  (or  $W$ ) to be in proportion to  $U$ , the flow rate  $Q$  must therefore vary as  $\Omega r^3$ ; hence, the “specific flow”  $Q_s$  must be constant (Eq. 28). Further, as the head is the product of two velocities, it must vary as  $\Omega^2 r^2$ ; hence, the head coefficient  $\psi$  must be constant (Eq. 31). Finally, as power is the product of pressure-rise and flow rate, shaft power  $P_s$  must vary as  $\rho \Omega^3 r^5$ ; hence, the power coefficient must be constant.

$$Q = AV \quad \begin{cases} A \propto r_2^2 & \propto D^2 \\ V \propto \Omega r_2 & \propto ND \end{cases}$$

$$\Rightarrow Q \propto ND^3 \quad \text{or} \quad \Omega r_2^3 \quad (27)$$

and 
$$\frac{Q}{\Omega r_2^3} = \text{Constant} = Q_s \quad (28)$$

At above  $Q_c$ ,

$$\begin{aligned} \eta &= \text{Constant, and} \\ g\Delta H &= \eta_{HY}\Delta(UV_\theta) \\ &\Rightarrow \Delta H \propto N^2D^2 \end{aligned} \quad (29)$$

$$U = \Omega r \quad (30)$$

and 
$$\psi = \frac{g\Delta H}{U^2} = \text{constant} \quad (31)$$

$$\begin{aligned} P_S &= \frac{\rho Q g \Delta H}{\eta} \\ &\Rightarrow P_S \propto \rho N^3 D^5 \end{aligned} \quad (32)$$

and 
$$\hat{P}_S = \frac{P_S}{\rho \Omega^3 r_2^5} = \text{constant} \quad (33)$$

Figure 7a is the result of following these similarity rules for a given pump that undergoes a change in speed from full speed to half speed without a change in size. The similar  $Q$  at half speed for a given  $Q$  at full speed is half that at full speed. At each such half-speed  $Q$ -value, the head  $\Delta H$  is accordingly one-fourth of its full-speed value and the efficiency  $\eta$  is unchanged. One can avoid replotting the characteristic curves in this manner for every change in speed (and size) by expressing them nondimensionally in terms of  $Q_s$ ,  $\psi$ ,  $\eta$ , and  $\hat{P}_s$ . They then all collapse on one another as illustrated in Figure 7b. Note that a change in pump geometry or shape of the hydraulic passageways destroys this similitude and necessarily produces a new set of curves—shaped differently but similar to each other.

Similitude enables the engineer to work from a single dimensionless set of performance curves for a given pump model. This is a practical but special case of the more general statement that pump performance as represented by efficiency, head, and power, is more generally expressed in terms of the complete physical equation as follows:

$$\eta, \Delta H, P_S = \text{fct's.} (Q, r_2, \Omega, \rho, \nu, NPSH, \{2-ph\}, \{g_p\}, \{S\}, \{\ell_i\}) \quad (34)$$

where  $\{\ell_i\}$  is the infinite set of lengths that defines the pump stage geometry. A common group of these lengths is illustrated in Figure 8. Dimensionlessly, Eq. 34 becomes

$$\eta, \psi, \hat{P}_S = \text{fct's.} (Q_s, R_e, \tau_2, \{2-\Phi\}, \{\Gamma_p\}, \{\Sigma\}, \{G_i\}) \quad (35)$$

where the dimensionless quantities containing flow rate, viscosity and  $NPSH$  are respectively defined as follows:

$$\begin{aligned} \text{where} \quad Q_s &= \frac{Q}{\Omega r_2^3} & R_e &= \frac{\Omega r_2^2}{\nu} & \tau_2 &= \frac{2gNPSH}{\Omega^2 r_2^2} \\ \text{Specific Flow} & & \text{Machine Reynolds Number} & & \text{Cavitation Coefficient} & \end{aligned} \quad (36)$$

and

- $\{G_i\} = \{\ell_i/r\}$  defines the dimensionless geometry or shape.
- $\{2-\Phi\}$  = the dimensionless quantities arising from the set of fluid, thermal, vaporization, and heat transfer properties  $\{2-ph\}$  that influence the flow of two-phase vapor and liquid. These quantities come into play when the  $NPSH$  is low enough for such flow to be extensive enough to influence pump performance.

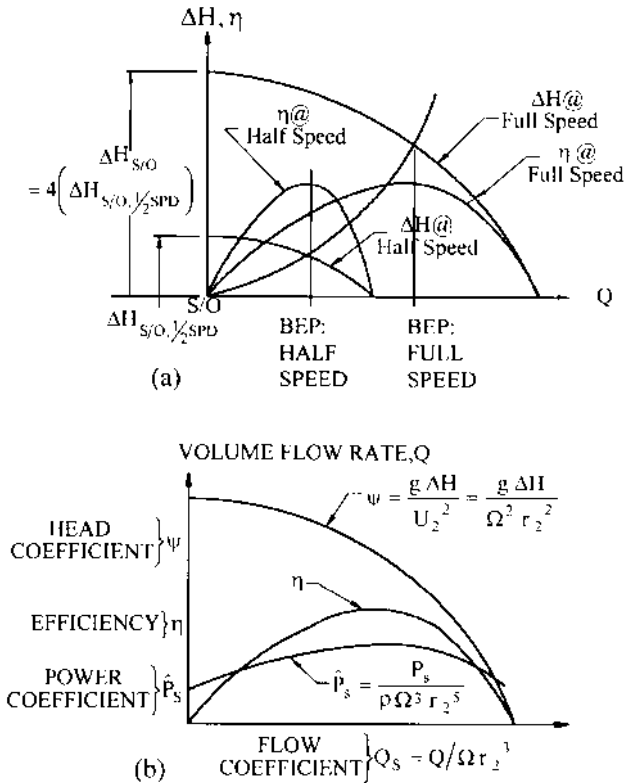


FIGURE 7 Similar performance curves: a) dimensional; b) dimensionless

- $[\Sigma]$  = the dimensionless quantities arising from the set of properties associated with entrained solids and emulsifying fluids that affect the performance of slurry pumps and emulsion pumps.

### SPECIFIC SPEED AND OPTIMUM GEOMETRY

The hydraulic geometry or shape of a pump stage can in principle be chosen for given values of the other independent variables in Eqs. 34 or 35 to optimize the resulting performance; for example, to maximize the best efficiency  $\eta_{BEP}$  under certain conditions on the head and power. Two such conditions that are common are a) no positive slope is allowed anywhere along the  $\Delta H$ -vs.- $Q$  curve of Figure 7 (called the “no drooping nor dip” condition) and b) the maximum power consumption must occur at the BEP (often called the “non-overloading” condition). A fundamental and generally typical pumping situation involves a) negligible influence of viscosity, (that is, high Reynolds number) b) the absence of two-phase fluid effects, (that is, the existence of sufficient *NPSH* or  $\tau$ ) and c) the absence of solid particles and emulsion-related substances in the fluid. In this situation, Eq. 35 has one remaining significant independent variable; namely, the specific flow  $Q_s$ , which in the definitions of Eq. 36 contains the volume flow rate  $Q$ , the pump speed  $\Omega$ , and the characteristic radius  $r_2$ . Most users don't know the

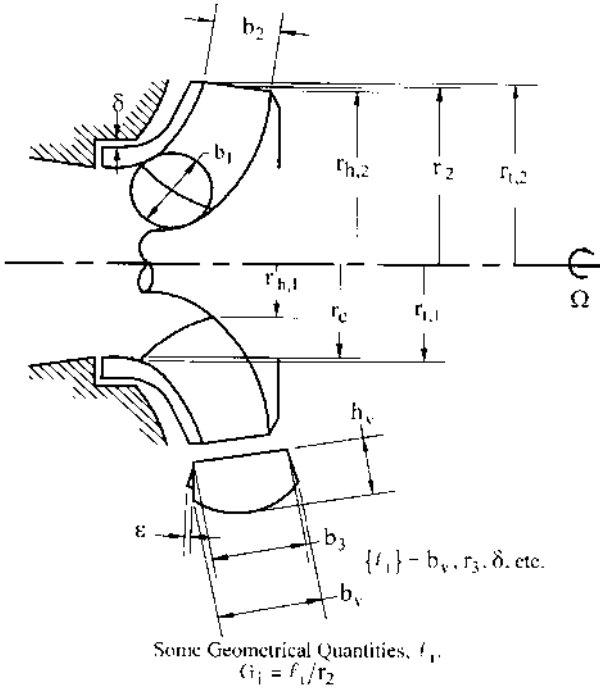


FIGURE 8 Defining the geometry of a pump stage

size of the pump stage a priori; so,  $r_2$  is eliminated by replacing  $Q_s$  in Eq. 35 with a new quantity that is the result of dividing the square root of  $Q_s$  by the  $\frac{3}{4}$ -power of the head coefficient  $\psi$ . Thus, from the definitions just given of  $Q_s$  and  $\psi$ , one arrives at the *specific speed*  $\Omega_s$  as the independent variable in terms of which the geometry is optimized<sup>3</sup>:

$$\Omega_s = \frac{\Omega \sqrt{Q}}{(g\Delta H)^{3/4}} = \frac{\sqrt{Q_s}}{\psi^{3/4}} \tag{37}$$

For convenience, specific speed is usually expressed in terms of the conventional quantities  $N$ ,  $Q$ , and  $\Delta H$  that correspond to the factors in Eq. 37, which quantities are expressed in the units commonly used commercially. For example, forms found in the United States and in Europe and the relationship of these to the truly unitless “universal specific speed”  $\Omega_s$  defined in Eq. 37 are as follows:

$$\Omega_s = \frac{N(\text{rpm})\sqrt{Q(\text{USgpm})}/[\Delta H(\text{ft})]^{3/4}}{2733.016} = \frac{N_{s,(\text{U.S.})}}{2733.016} \tag{38a}$$

$$\Omega_s = \frac{N(\text{rpm})\sqrt{Q(\text{m}^3/\text{s})}/[\Delta H(\text{m})]^{3/4}}{52.919} = \frac{n_q}{52.919} \tag{38b}$$

Thus,

$$n_q(\text{m}^3/\text{s}, \text{m}) = N_s(\text{USgpm}, \text{ft})/51.64 \tag{38c}$$

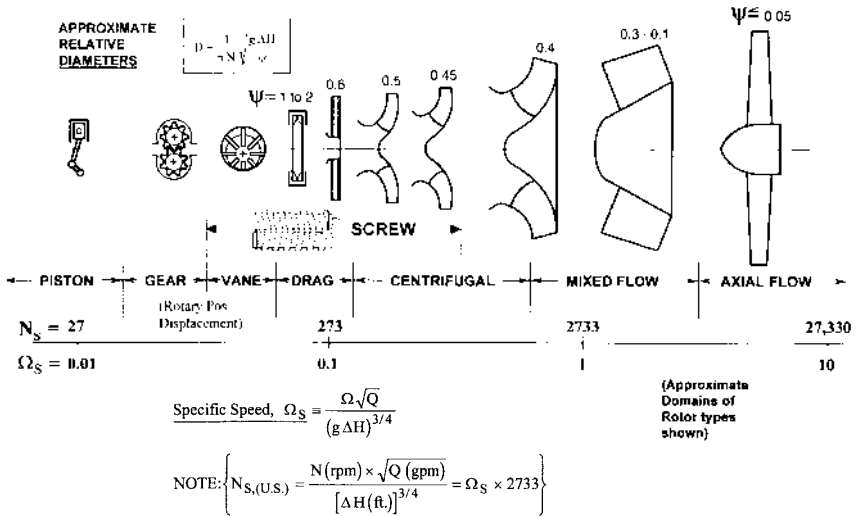


FIGURE 9 Optimum geometry as a function of BEP specific speed (for single-stage rotors)

**Rotor Shape as a Function of Specific Speed** Optimization of pump hydraulic geometry in terms of the BEP specific speed has taken place empirically and analytically throughout the history of pump development. An approximate illustration of the results of this process for pump rotors or impellers is shown in Figure 9. Not only does the geometry emerge from the optimization process but also the head, flow, and power coefficients for each shape as well. Approximate values for the optimum BEP head coefficient  $\psi$  are shown on the figure. The actual rotor diameter can then be deduced as noted—from the  $\psi$ -definition of Eq. 31. The relationship among the various rotors is illustrated in the figure—assuming that they all have the same speed and head; that is, as one moves along the abscissa or specific speed axis of Figure 9, only the flow rate is changing as far as the illustrations of the rotors are concerned. As would be expected, therefore, high-specific-speed impellers need to have large passages relative to their overall diameter. This is powerfully illustrated if one contrasts the propeller (high- $\Omega_s$ ) with the low- $\Omega_s$  centrifugal impeller.

At the lower end of the specific speed range shown in Figure 9, rotodynamic pumps (that is, centrifugal pumps, in which category mixed- and axial-flow geometries are generally included) would be too low in efficiency to be practical. Rather, rotary positive displacement pumps take over because there is a transition through the drag pump domain. Sometimes called a regenerative or periphery pump, the drag pump is actually a rotodynamic machine, developing head peripherally around the impeller through successive passages radially through the blades on both sides until a barrier is reached at some point on the periphery, where the fluid is then discharged.<sup>5</sup>

The screw pump, on the other hand, is a truly positive displacement (rotary) machine. It can have two, three, or more meshing screws and can move large quantities of fluid—both single- and multiphase—against a large pressure difference  $\Delta p$ , giving it a specific speed range that extends well into centrifugal pump territory. Not shown is the progressive cavity pump, which has a single screw surrounded by an elastomer sealing member.

Lower flow rates are readily accommodated by the vane pump, whereas gear pumps handle a higher range of pressure differences at such flow rates. Finally, extremely high pressures are produced by reciprocating pumps, the specific speed range of which extends off the figure on the left.



Positive displacement pumps appear in Figure 9 in order to provide perspective. The concept of specific speed is not generally applied to these machines, because a given positive displacement pump can have such a wide range of pressure-rise capability at a chosen flow rate and speed as to make it difficult to associate a given rotor geometry with a particular value of specific speed. On the other hand, a unique rotodynamic pump geometry is readily associated with the specific speed of the BEP of such a machine.

**Performance of Optimum Geometries** Figure 9 enables one to easily identify the pump stage types associated with required pumping tasks in terms of head, flow rate, and rotative speed. Beyond this general picture is the related performance of a real pump geometry in a real fluid. Although, for centrifugal pumps, the specific speed has the major effect on performance, the available *NPSH* and the viscosity of the pumpage also have an influence. These are evident in the following formal statement of the efficiency of an optimized pump (cf Eq. 35)

$$(\eta_{\max})_{\{G_i\}_{\text{opt}}} = f(\Omega_s, \Omega_{ss}, \{2\text{-}\Phi\}, \{\Gamma_p\}, \{\Sigma\}, R_{e,H,Q}) \quad (39)$$

where the radius  $r_2$ , representing the size, has been eliminated from the other variables in Eq. 35 by introducing the *suction specific speed*  $\Omega_{ss}$  and the *head-flow Reynolds number*  $R_{e,H,Q}$ , which are defined in Eqs. 40 and 41:

$$R_{e,H,Q} = \frac{\sqrt{Q} (g\Delta H)^{1/4}}{\nu} = R_e \sqrt{Q_s} \psi^{1/4} \quad (40)$$

$$\Omega_{ss} = \frac{\Omega \sqrt{Q}}{(g \text{NPSH})^{3/4}} = \frac{\sqrt{Q_s}}{(\tau_2/2)^{3/4}} \quad (41)$$

where, the common form of the suction specific speed, called  $N_{ss}$ , is given in commercial U.S. units by (Eq. 42)

$$N_{ss, (\text{U.S.})} = \frac{N(\text{rpm}) \sqrt{Q(\text{gpm})}}{[\text{NPSH}(\text{ft})]^{3/4}} = \Omega_{ss} \times 2733.016 \quad (42)$$

**Size Effect** For sufficiently high *NPSH* (or sufficiently low suction specific speed) and low viscosity (or high Reynolds number), real pumps also possess a strong size effect on efficiency. This is because, in normal manufacturing processes, the clearances  $\delta$  preventing internal leakage  $Q_L$  (for example, past the impeller sealing rings in Figure 2) do not scale up as rapidly as the size (represented by  $r_2$ ), nor do the surface roughness heights  $\varepsilon$ . Thus, a larger pump tends to be more efficient. Strictly speaking, however, the geometry of the larger pump is not the same as that of the smaller pump, and this forces one to modify Eq. 39 by reintroducing two of the length ratios  $G_i$  that were part of the set  $\{G_i\}$  in Eq. 35 which characterize the hydraulic shape of the machine. Thus, Eq. 39, revised to reflect these realities, becomes

$$(\eta_{\max})_{\{G_i\}_{\text{opt}}} = f_1 \left( \Omega_s, \Omega_{ss}, R_{e,H,Q}, \{2\text{-}\Phi\}, \{\Gamma_p\}, \{\Sigma\}, \frac{\varepsilon}{r_2}, \frac{\delta}{r_2} \right) \quad (43)$$

A study of a large number of commercial centrifugal pumps by H. H. Anderson<sup>6</sup> has quantified Eq. 43 for such machines. These pumps were all operating in water and had sufficient *NPSH* for performance not to be influenced by  $\Omega_{ss}$ . The results are given by Eq. 44, which is plotted in Figure 10:

$$\eta = 0.94 - 0.08955 \times \left[ \frac{Q(\text{gpm})}{N(\text{rpm})} \times X \right]^{-0.21333} - 0.29 \times \left[ \log_{10} \left( \frac{2286}{N_s} \right) \right]^2 \quad (44)$$

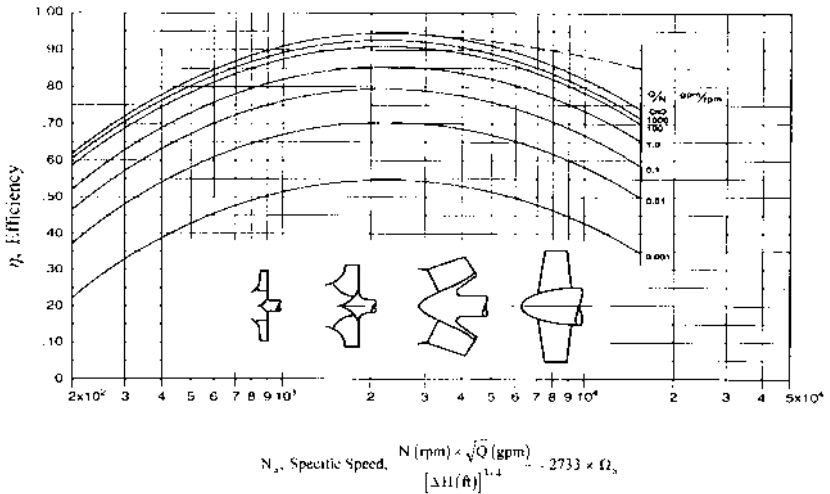


FIGURE 10 Efficiency of centrifugal pumps versus specific speed, size, and shape—adapted from Anderson<sup>6</sup>. Note: Actual experience for  $N_s > 2286$  shows higher efficiency, as indicated by the dashed line.

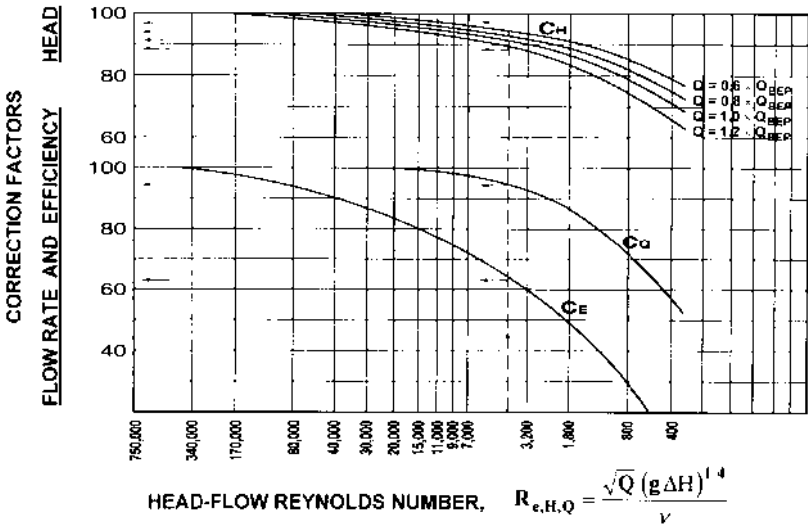
$$\text{where } X = \left[ \frac{140}{\varepsilon(\mu - \text{in.})} \right]^2$$

Eq. 44 is a combination of separate relationships described by Anderson for efficiency and speed as functions of flow rate<sup>6</sup>. Included is a correction for specific speed that is too conservative for  $N_{s(\text{U.S.})} > 2286$  or  $\Omega_s$  greater than about unity. With this qualification, Figure 10 is a useful representation for centrifugal pumps and is often as far as many users go in determining the performance of these machines.

**Viscosity Effects** Centrifugal pump geometries have not generally been optimized versus Reynolds number—often because the effect on hydraulic shape is not very great except for the highest viscosities of the pumpage, and a given application can sometimes experience a substantial range of viscosity. Studies of conventional centrifugal pumps over a range of Reynolds number have been combined in nomographic charts in the Hydraulic Institute Standards, which yield correction factors to the head, efficiency, and flow rate of the BEP of a low-viscosity pump in order to obtain the BEP of that pump when operating at higher viscosity<sup>7</sup>. Figure 11 is a presentation of these correction factors in terms of the head-flow Reynolds number. Strictly speaking, in view of Eq. 43, each pump geometry has a unique set of such correction factors, yet the data presented in Figure 11 have been widely utilized as reasonably representative of conventional centrifugal pumps.

**NPSH Effects** In many cases, the available *NPSH* is low enough, or the suction-specific speed  $\Omega_{ss}$  at which the pump stage must operate is high enough for significant two-phase activity to exist within the impeller. This is to be expected in centrifugal impellers of water pumps if the available  $\Omega_{ss}$  is greater than about 3 to 4 (or  $N_{ss(\text{U.S.})} = 8,000$  to 11,000). In such a case,  $\Omega_{ss}$  and the vaporization quantities  $\{2-\Phi\}$  in Eq. 35 dictate a profound change in the impeller geometry into that of an inducer. The inducer has an entering or “eye” diameter that is significantly enlarged—together with tightly wrapped helical blading. Often the inducer is a separate stage that pressurizes the two-phase fluid as needed to provide a sufficiently low value of  $\Omega_{ss}$  at the entrance of the more typical impeller blading that is immediately downstream of the inducer. If the two-phase fluid is near its thermodynamic critical point, the  $\{2-\Phi\}$  operate to greatly reduce the amount of two-phase

## Viscous Fluid Effects on Pumps



**FIGURE 11** Viscous fluid effects on centrifugal pumps—adapted from Hydraulic Institute ANSI/HI 2000 Edition Pump Standards, Reference 7.

activity within the pump. (At the critical point, the liquid and gas phases are identical, and therefore both have the same specific volume.) An example is the pumping of liquid hydrogen, for which an inducer is unnecessary until much higher values of  $\Omega_{ss}$  are reached. Moreover, inducers—typically limited to  $\Omega_{ss}$ -values of about 10 ( $N_{ss,US} = 27,000$ ) in water—can, at sufficiently low tip speed, operate at zero *NPSH*, which corresponds to an infinite value of  $\Omega_{ss}$ <sup>8</sup>.

**Pumping Entrained Gas** In addition to the liquid’s own vapor (which is the gas involved in the *NPSH*-effects discussion), many pumping applications deal with a different gas; that is, a different substance from the liquid being pumped. The effects of this gas on performance arise from a) the volume flow rate of the gas at the inlet, b) the pressure ratio of the pump, which determines how far into the impeller this gas volume persists; that is, how much it gets compressed, and c) how much of the gas dissolves in the liquid as the pressure increases within the pump, which depends on both the solubility and the degree of agitation of the fluid produced by the pump. The set of fluid properties associated with these gas-handling phenomena are represented by ( $g_p$ ) in Eq. 34, the dimensionless form (Eqs. 35 and 43) of this set being ( $\Gamma_p$ ). Generally, for typical commercial centrifugal pumps, the performance under such conditions usually manifests itself as a loss of pressure rise, which is reasonably stable up to an inlet volume flow rate fraction of gas to liquid of 0.04 to 0.07<sup>9</sup>. Inducers can handle larger inlet volume fractions of gas, and, under Dalton’s law for partial pressures, the liquid’s own vapor also occupies the volume of the gas bubbles. Single and multistage centrifugal pumps have been built that handle far greater gas volume than these single-stage values<sup>10,11</sup>; moreover, multiphase rotary positive displacement screw pumps can handle gas volume fractions up to 1 (100 percent gas)<sup>11</sup>.

**Effects of Slurries and Emulsions** Finally there is the influence of the dimensionless quantities ( $\Sigma$ ) in Eq. 43. Impeller and casing design are altered so as to reduce wear-producing velocities if the pumpage is a slurry of solids contained in a carrier liquid. (Slurry pumps are usually single-stage machines with a collector or volute casing sur-

rounding the impeller.) This usually means a smaller impeller eye diameter (which, as can be seen in Figure 6, reduces the inlet relative velocity  $W_{1i}$ ) and a larger radial distance from the impeller to the surrounding volute because the circumferential velocity component  $V_{\theta}$  of the fluid emerging from the impeller (also seen in Figure 6) slows down with increasing radial position and is then lower in the volute passageway<sup>12</sup>. Performance also is altered, depending on the composition and concentration of the slurry. These are complicated non-Newtonian flows and are covered in detail elsewhere in this book in conjunction with a thorough treatment on solids-handling pumps. Emulsions are another example of such flows, many of which are destroyed by excessive local shear in the fluid. For this reason, screw pumps are sometimes utilized for emulsions rather than oversized, slow-running centrifugal pumps. Except for thin layers of the fluid at the clearances, most of the flow in a screw pump experiences very little shear in comparison to the flow through a centrifugal pump.

**Electromagnetic Effects** Not appearing in Eq. 43 are quantities associated with electromagnetic phenomena. For example, electric current flowing radially outward through fluid contained in an axially directed magnetic field is capable of producing a rotating flow. Called a hydromagnetic pump, this device is therefore “centrifugal,” yet it has no moving parts. Such pumps have been used for liquid metals and could be made reasonably efficient for any pumpage with high conductivity.

## DESIGN PROCEDURES

---

**Establishing the Pump Configuration** The first step in designing a pump is to determine the type and number of stages that are needed to meet the given set of operating conditions, usually  $Q$ ,  $p_1$ ,  $p_2$ , available  $NPSH$  ( $= NPSHA$ ) and specific gravity of the fluid. If the pump must meet several such sets of operating conditions, one set has to be chosen for the BEP or design point so all the others are satisfied, if possible. Making the proper choice of this BEP may require some iteration: first making a trial choice, doing a preliminary design, and determining the corresponding pump performance characteristic curves, and then repeating these steps if necessary.

Pump rotative speed  $N$  (rpm) must be chosen in order to proceed. Selection of the highest practical rpm is desirable because it yields the smallest size and therefore usually the lowest cost and easiest containment of system pressure. If, for the chosen number of stages, the stage specific speed is too low, Figure 10 indicates that efficiency is generally improved with greater speed. The maximum possible rpm is that which yields a value for the suction specific speed  $\Omega_{ss}$  (Eq. 41) or  $N_{ss}$  (Eq. 42) that the first stage of the pump can accommodate, where  $NPSH$  is found from Eq. 41 as follows:

$$NPSH = \frac{1}{g} \left( \frac{\Omega}{\Omega_{ss}} \right)^{4/3} Q^{2/3} \quad (45)$$

Typically, the  $\Omega_{ss}$ -capability of an impeller does not exceed a value that is somewhere in the range 3 to 4.5 ( $N_{ss} = 8,200$  to 12,300), depending on minimum (off-design) flow rate requirements, and it is typically 10 (27,000) or less for inducers. Generally, the supplier furnishes a pump that has a value of  $NPSH$ -capability (or “ $NPSHR$ ”) smaller than the stated  $NPSHA$ . This difference or “ $NPSH$ -margin” is desirable if there is any uncertainty as to the true value of  $NPSHA$ . It is essential for high values of  $\Delta p_{stg}$ ; (see discussion of “high-energy pumps” further on in this section.) Often a higher speed can be employed if a double-suction impeller (entry of fluid from both sides) can be used, as then only half of the given  $Q$  enters each side of this impeller, and only that half can be used in the  $\Omega_{ss}$ -equation applying to that fluid and impeller type.

The double-suction configuration is popular for large, single-stage pumps because the axial thrust is nominally zero. It is also found as the first stage in some multistage pumps, in which case the arrangement of the remaining impellers can be “back-to-back” (half of them facing in one direction and half opposite) to achieve axial thrust balance. On the

other hand, the interstage flow passages are simpler if these impellers are all facing in the same direction—in which case the thrust is opposed by a balancing drum or disk as described in Section 2.2.1. Forming the specific speed from  $N$ ,  $Q$ , and  $\Delta H$  (from Eq. 3) and referring to Figure 9 for the kind of impeller (which then gives one an idea of the other hydraulic components (inlet passage, diffuser and collector, and so on) and Figure 10 for the expected efficiency, one can decide whether the pump would perform better and still meet any installation and size restrictions with more than the one stage implied by this first  $N_s$ -calculation.

If the user requires the performance characteristics of a positive displacement pump—such as a wide range of pressure-rise at a nearly constant flow rate  $Q$ —selecting such a pump may be possible if the specific speed is not too high. (See Figure 9.) The choice of speed for positive displacement pumps is sometimes determined by mechanical considerations rather than suction capability.

**Sizing the Pump** The next step is to determine the approximate size of a pump or pump installation. Beginning with the impeller, the agent of the energy transfer to the fluid in a pump, one utilizes the results of the pump hydraulic geometry optimization process. This also yields the proportions of the velocity diagrams that correspond to the geometry associated with the desired value of specific speed. These in turn lead to two major sizing factors for an impeller, which are plotted for typical commercial pumps in Figure 12; namely the head coefficient  $\psi$  (originally defined in Eq. 31) and the outlet flow coefficient  $\phi_i$  defined on this figure<sup>4</sup>. Equations in the figure show how these factors are used to determine the exit radius  $r_2$  (or diameter  $D_2$ ) and the width  $b_2$  (Figure 8) respectively. The flow coefficient  $\phi_i$  is obviously a velocity component ratio. For the head coefficient of a pump with zero inlet prewhirl to the impeller (that is,  $V_{\theta,1} = 0$ ), the relevant

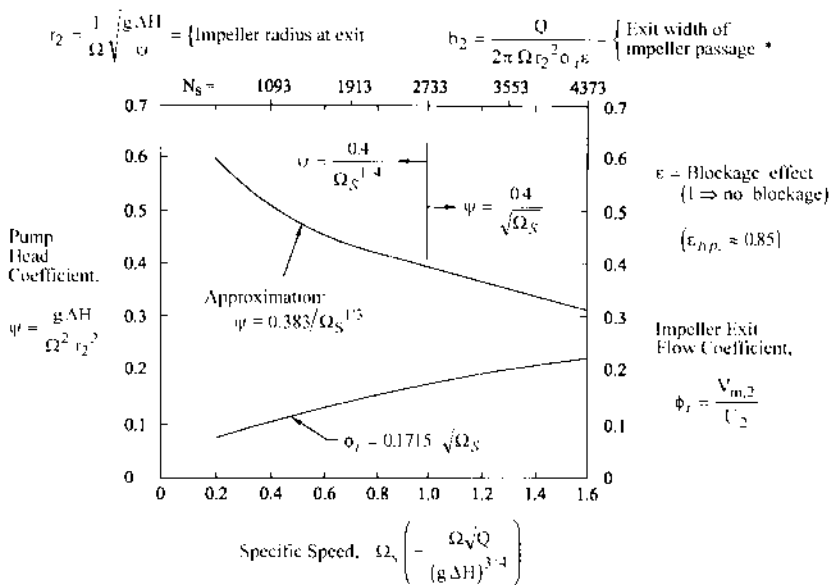


FIGURE 12 Sizing factors for the diameter and width of typical impellers—adapted from Stepanoff<sup>4</sup>.

velocity ratio (see Figure 3) is  $V_{\theta,2}/U_2$ , which in view of Eqs. 15b and 31 is equal to the ideal head coefficient  $\psi_i$ , as this corresponds to the ideal head  $H_i$ . Referring to Eq. 15c, it is obvious that the actual head coefficient  $\psi = \eta_{HY} \times \psi_i$ , or, in the (common) case of zero prewhirl,  $\psi_i = V_{\theta,2}/U_2$ .

Overall pump dimensions are conveniently viewed in terms of factors times the impeller diameter. The overall diameter exceeds that of the impeller due to the surrounding casing. For single stage pumps, this casing will include a volute and perhaps a set of diffuser vanes immediately surrounding the impeller; so, the casing diameter can be 50% greater than  $D_2$  or more. On multistage pumps (many with radial-outflow diffusers and return vanes), this excess is often less than 50%.

Single-stage pump axial length includes provision for inlet passageways and bearing housings and is therefore approximately the same as the overall pump diameter. On the other hand, the axial length of a stage in a multistage pump is often less than half of the impeller diameter. Minimizing this "stage length" (and diameter) is a goal of competitive pump designers in the quest to create a machine of light weight and low cost. But too small a stage length is accompanied by inferior hydraulic performance because not enough room is provided for the passages around and within the impeller to turn the fluid with minimum loss. Further, the bearing housings and the suction and discharge "heads" or end pieces must be considered in arriving at the overall length of a multistage pump.

This sizing discussion so far has focused on pumps with a radial-outflow geometry. For the axial-flow geometries of higher specific speeds, the situation is simpler. The diameters of the propeller (Figure 9) and any stationary vanes downstream (or upstream) are essentially the same. The approach and discharge piping is of about the same size. A simple guideline for the maximum radius of the propeller is found from the following approximate extrapolation of the  $\psi$ -curve of Figure 12:

$$\psi_t = \frac{0.53}{\Omega_s} \quad (46)$$

where the outer radius of the propeller  $r_{t,2}$  should be substituted for the mean exit radius  $r_2$  in the  $\psi$ -definition. Thus the  $\psi$ -curve is in reality a  $\psi_t$ -curve for non-radial-flow pumps. For small departures from radial flow, as illustrated in Figure 8, the  $\psi$ -curve of Figure 12 can be used either way.

These guidelines are often all that pump users or fluid system designers need to plan their installations. To get beyond this overview, one must pursue the hydraulic design in detail—as afforded by the following development and examples.

**Designing the Impeller** Determination of the geometrical features of the impeller is generally accomplished in the following order: a) the "eye" radius  $r_e$ , b) the exit radius  $r_2$  or  $r_{t,2}$ , and c) the exit width  $b_2$  or, in the case of mixed- and axial-flow impellers, the hub exit radius  $r_{h,2}$ —all of which form the starting point for d) shaping the hub and shroud profiles (Figure 13); and, finally, e) construction of the blades.

a) *The eye.* The inlet radius of the impeller eye  $r_e$  (Figure 13) is nearly the same as  $r_{t,1}$ , which is the diameter of the tips of the impeller blades at the inlet. This emerges after the eye flow coefficient  $\phi_e = V/U_e$  [the ratio of the one-dimensional axial velocity entering the eye (Figure 8) to the tangential speed of the impeller eye  $U_e = \Omega r_e$ ] is known:

$$\phi_e = \frac{Q/A_e}{\Omega r_e} = \frac{\bar{V}_e}{U_e} \quad (47)$$

$$A_e = \pi(r_e^2 - r_s^2) \quad (48)$$

Thus,  $r_e$  can be found from the following combination of Eqs. 47 and 48:

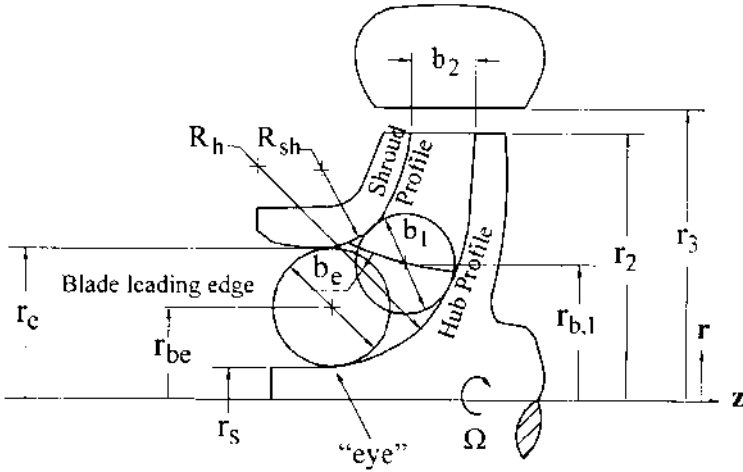


FIGURE 13 Hub and shroud profiles of centrifugal pump impeller

$$r_e = \left[ \frac{Q}{\pi \Omega \phi_e \left( 1 - \frac{r_s^2}{r_e^2} \right)} \right]^{1/3} \tag{49}$$

where the shaft-to-eye ratio  $r_s/r_e$  can be estimated at first. Typical values for  $\phi_e$  vary from 0.2 to 0.3 for impellers and down to 0.1 or less for inducers, depending on suction conditions, as can be seen from its relationship to suction-specific speed:

$$\Omega_{ss} = \frac{\Omega \sqrt{Q}}{(g NPSH)^{3/4}} = \sqrt{\pi \phi_e \left( 1 - \frac{r_s^2}{r_e^2} \right)} / (\tau/2)^{3/4} \tag{50}$$

where the cavitation coefficient  $\tau$  (cf.  $\tau_2$  in Eq. 36) is defined in terms of the eye speed  $U_e = \Omega r_e$  (Table 1).  $\tau$  is related to  $\phi_e$  through empirical correlations, such as those given in Table 1. (Gongwer's<sup>13</sup> values for the correlation factors  $k_1$  and  $k_2$  apply to large pumps. The larger "typical" values shown for 3% breakdown apply to the more common smaller sizes. The inducer correlation is a curve fit to the data of Stripling and Acosta<sup>14</sup> for the breakdown value of  $\tau$ .) Thus one can solve for  $\phi_e$  from a given suction-specific speed and, through Eq. 49, obtain the eye size. However, the value of  $\phi_e$  at the BEP or design point rarely exceeds 0.3, regardless of how much *NPSH* is available. This  $\phi_e$ -limit therefore applies to impellers that follow and are in series with the first stage in a multistage pump. These are variously referred to as "series" or "intermediate" stages. (Slurry pump impellers are an exception to this guideline, for then the relative velocity is minimized to avoid excessive wear. In this case  $\phi_e$  can be as high as 0.4 and *NPSHA* is generally more than adequate for these slow-running machines.)

*b) The exit radius  $r_2$  (or diameter  $D_2$ ).* This is found from head-coefficient  $\psi$  by means of the equation for  $r_2$  in Figure 12. The upper curve for  $\psi$  can be used unless detailed performance analysis or a desired non-typical performance characteristic curve indicates otherwise. Eq. 46 can be used for specific speeds  $\Omega_s$  greater than 1.6 ( $N_s > 4373$ ), where the maximum radius  $r_{t,2}$  is computed per the previous discussion accompanying that equation.

*c) The exit width  $b_2$ .* The equation for exit passage width  $b_2$  in Figure 12 can be used for radial-outflow and mixed-flow impellers,  $r_2$  being located halfway across the passage. This

TABLE 1 *NPSH* correlations

$$\tau \equiv \frac{\text{NPSH}}{U_e^2 \cdot 2g} \quad \Omega_{ss} = \frac{\sqrt{\pi \phi_e \left(1 - \frac{r_h^2}{r_e^2}\right)}}{(\tau \cdot 2)^{3.4}}$$

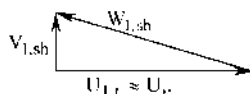
For breakdown in pressure rise due to two-phase activity in pump

a) Impellers (Gongwer<sup>13</sup>)  $\tau = k_1 \frac{V_e^2}{2g} + k_2 \frac{W_{l,sh}^2}{2g}$

$$\text{NPSH}_{3\%} = \left( \frac{k_1}{V_e} \right)^{1/n} \frac{V_e^2}{2g} + k_2 \frac{W_{l,sh}^2}{2g}$$

$$(\forall \theta, l = 0): \quad \tau_{3\%} \equiv \frac{\text{NPSH}_{3\%}}{U_e^2 \cdot 2g} = (k_1 + k_2) \phi_e^2 + k_2$$

$$\phi_e = \frac{V_e}{U_e} = \frac{Q \cdot A_e}{\Omega \cdot r_e}$$



	Gongwer <sup>13</sup> (Large pumps)	Typical (3% breakdown)
$k_1$	1.4	1.69
$k_2$	0.085	0.102

b) Inducers (curve fit to the data of Stripling & Acosta<sup>14</sup>)

$$\tau = 0.02 + 0.02 \left[ \log_{10} \left( \frac{\phi_e \sin \beta_{1,b,sh}}{1 + \cos \beta_{1,b,sh}} \right) + 3 \right]^{3.5}$$

involves the exit flow coefficient or meridional velocity ratio  $\phi_i = V_{m,2}/U_2$ , the lower curve of Figure 12 being for typical values of this quantity. The “openness” factor  $\varepsilon$  allows for blockage due to blade thickness and to the buildup of boundary layers on the surfaces of the passageways (blades and hub and shroud). The value of  $\varepsilon$  is generally between 0.8 and 0.9, the higher figure applying to larger machines. For axial-flow impellers or propellers and inducers, a choice of the hub-to-tip radius ratio at the exit defines the passage width instead. This ratio decreases with specific speed from about  $\frac{2}{3}$  at the right end of Figure 12 to  $\frac{1}{3}$  or less at the highest specific speeds.

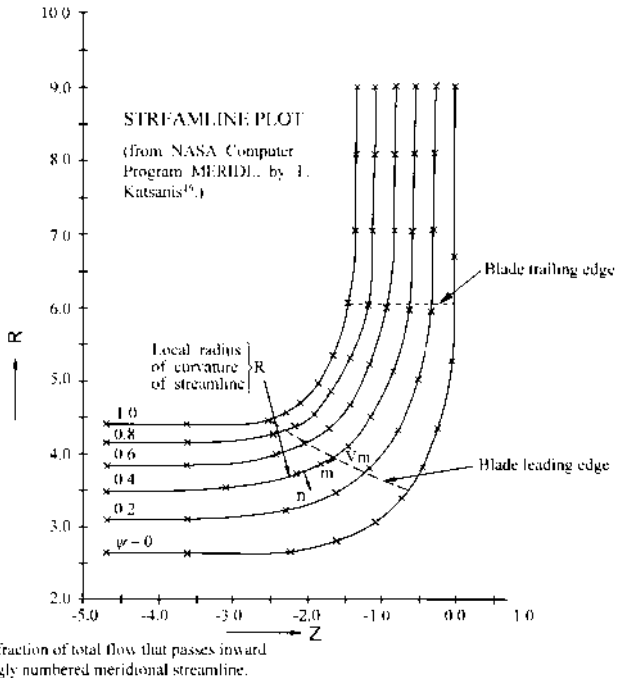
d) Hub and shroud profiles. With the eye and the outlet sizing established, the two are connected by specifying the hub and shroud profiles. Some texts illustrate the variation of hub and shroud profiles with specific speed<sup>15</sup>. Although these are excellent guidelines coming from experience, what follows is the approach one would take to synthesize these



shapes on the basis of fundamental fluid dynamical considerations, at the same time taking experience into account. Referring to Figure 13, an acceptable geometry can be achieved by following these guidelines:

- i. Maintaining the meridional flow area  $2\pi r_{b,1}b_1$  at the blade leading edge at about the same as it is at the eye, namely  $\pi(r_e^2 - r_s^2)$ , but then gradually increasing it versus meridional distance to the generally larger value already established at the exit, namely  $2\pi r_2b_2$ .
- ii. Choosing the minimum radius of curvature  $R_{sh}$  of the shroud to be about half the radial opening at the eye. This avoids excessive local velocity  $V_{1,sh}$  at the blade leading edge. This has two consequences. Shaping the impeller blades to match a widely varying meridional approach velocity can complicate the construction of these blades. Also, on first-stage impellers, if  $V_{1,sh}$  is too great, the local pressure at that location will be closer to the vapor pressure, increasing the required *NPSH* (or *NPSH*<sub>3%</sub>). This is due to a larger resulting value of the empirical factor  $k_1$ , presented in Table 1 as the  $n^{\text{th}}$  power of the velocity ratio  $V_{1,sh}/V_e$ . Single-phase theory would require that the exponent  $n = 2$ , but two-phase activity in the pump reduces the local pressure reduction that a single-phase application of Bernoulli's equation would indicate.

Figure 14 is a plot of the meridional streamlines in the space between the hub and shroud surfaces of the first-stage impeller of a high-energy boiler feed pump in the absence of blades. This was obtained from a computer solution via Katsanis' program<sup>16</sup> of the inviscid axisymmetric flow field, which is governed by the following equation:



**FIGURE 14** Axisymmetric flow analysis for the distribution of meridional velocity  $V_m$  along the blade leading edge (Eq. 51a)

$$\frac{dV_m}{dn} = \frac{V_m}{R} \quad (51a)$$

As the average value of  $V_m$  at the blade leading edge is about the same as its average  $V_e$  in the eye,  $V_{1,sh}$  can be estimated from the finite-difference form of this equation, which expresses the change in  $V_m$  from shroud to hub in terms of an average radius of curvature  $R$  of the meridional streamlines across the passage of width  $\Delta n$  from shroud to hub in the  $n$ -direction (normal to the streamlines in Figure 14):

$$\frac{\Delta V_m}{V_m} = \frac{\Delta n}{R} \quad (51b)$$

The estimated average  $R$  in Figure 14 is about twice the passage width  $\Delta n$ ; so, by the estimate of Eq. 51b,  $\Delta V_m/V_e = \frac{1}{2}$ . If half this difference is between  $V_e$  and  $V_{1,sh}$ , then  $V_{1,sh}/V_e \approx 1.25$ . The computer solution of the inviscid axisymmetric-flow Eq. 51a in this bladeless passage yields  $\Delta V_m/V_e = 0.73$  and  $V_{1,sh}/V_e = 1.45$  at this location<sup>16</sup>. Now, referring to Table 1, raising  $V_{1,sh}/V_e$  to the power 1.4 would produce the typical value of 1.69 given for  $k_1$ , which implies that the exponent  $n \approx 1.4$ . However, two real effects operate to bias  $V_{1,sh}/V_e$  toward lesser values; namely, a) greater loss of total pressure of flow entering the impeller along the shroud—due to wall friction and higher velocity, and b) shifting of the flow away from the shroud due to the presence of the impeller blades, which in conventional designs present the incoming flow with the greatest incidence at the hub. This serendipitous state of affairs tends to bring the value of  $n$  back toward 2. Moreover, the above estimate of  $V_{1,sh}/V_e \approx 1.25$  from Eq. 51b is more typical of the flow for which designers tend to set the impeller blades at the inlet.

These results are strongly influenced by the radius of curvature at the shroud  $R_{sh}$ , which in Figure 14 is about half of the passage width  $\Delta n$ . This accords with the guideline for  $R_{sh}$ .

- iii. Shaping the hub profile compatibly with the guidelines as stated earlier. This is best done after making an initial estimate of the shroud profile as outlined previously. The distribution of meridional flow area from the eye to the exit should then be specified. From this, a hub profile will emerge. As seen in Figures 13 and 14, the hub of a radial-outflow impeller becomes essentially radial over the outer portion of its extent. If this does not result from this procedure, appropriate adjustments can be made to the shroud profile and the process repeated.
- iv. For a high-specific-speed, axial-flow impeller, or inducer, the hub profile is often a cone or a reverse curve between a smaller radial location at inlet to a larger one at outlet, the latter radius decreasing with increasing specific speed as mentioned earlier. A cone or cylinder for the shroud profile is often found in such machines.

*e) Construction of the blades.* The blades are designed by i) selecting the locus of the leading and trailing edges in the meridional plane, ii) establishing the surfaces of revolution (streamwise lines in the meridional plane) from inlet to outlet along which the construction proceeds, iii) selecting the inlet angles, iv) selecting the outlet angles, v) establishing the number of blades, and vi) obtaining the blade coordinates from inlet to outlet:

- i. *Leading and trailing edge loci.* If every point along the leading and trailing edges is revolved about the axis of rotation so as to lie in one meridional plane, the loci of these edges appear as shown in Figure 13 or 14. The outer or shroud end of the blade leading edge is positioned at or near the minimum radial location; that is, at or near the eye plane, whereas the inner or hub end is typically well back and largely around the corner along the hub profile. These locations are desirable; first, at the shroud, because the absolute velocity  $V$  (typically  $= V_m$ ) approaching the blade begins to decelerate beyond the eye plane, so starting the blade ahead of this decelerating region tends to

prevent separation of the fluid from the shroud surface due to the pumping action in the blade channels<sup>17</sup>; and secondly, being far enough along the hub in the streamwise direction to avoid impractical blade shapes (excessive twist, rake, and so on) that would make both the construction and the flow inefficient. The locus of the blade trailing edges is normally straight in the meridional plane and is axial in orientation for most centrifugal pumps. At the higher specific speeds, this locus becomes more and more slanted until it takes on the nearly radial orientation it has for a propeller (Figure 9).

- ii. *Surfaces of revolution for blade construction.* Developing the coordinates of the blades along three streamwise surfaces of revolution—the hub, mean, and shroud, whose intersections with the meridional plane appear as streamwise lines in that plane—usually provides a sufficient framework for shaping the blades of an impeller. However, for high specific-speed impellers, where the passage width in the meridional plane  $\Delta n$  (Figure 14) is large (about equal to or greater than the meridional distance from leading to trailing edge), definition along two intermediate surfaces of revolution is also needed to achieve a satisfactory design.

The “mean” line is one that is representative of the flow from a one-dimensional standpoint as well as for the construction of the blades. Precisely, this is the mass-averaged or “50%” streamline (that is, the streamline for  $\psi = 0.5$  in Figure 14)—which evenly divides the mass flow<sup>17</sup>. This line is reasonably and conveniently approximated by the “rms streamline;” that is, the line that would result in a uniform meridional velocity distribution from hub to shroud and therefore equal areas  $2\pi r\Delta n$  normal to the meridional velocity component  $V_m$ . In this case,  $\Delta n (= \Delta b)$  is the spacing between the rms streamline and the hub or shroud line. This would put each point on the mean line at the root mean square radial position along a true normal to the meridional streamlines; hence, the “rms” terminology.

- iii. *Inlet blade angles.* The blade angles are set to match the inlet flow field. This is done where each of the previously chosen surfaces of revolution (that intersect the meridional plane in the streamwise lines just described) crosses the chosen locus of the blade leading edges in the meridional plane. At each such crossing point, an inlet velocity diagram of the type shown in Figure 3 is plotted in a plane tangent to the surface of revolution at that point. (Figure 3, representing a purely radial-flow configuration, is a view of such a plane, as the surfaces of revolution are then simply disks.) Each such velocity diagram or triangle contains a specific value of the angle  $\beta_{f,1}$  between the relative velocity vector  $W_1$  and the local blade speed vector  $U_1 = \Omega r_1$ .

The corresponding blade angle  $\beta_{b,1}$  between the mean camber line of the blade and the circumferential direction is set equal to  $\beta_{f,1}$  or slightly higher than this to allow for the higher  $V_{m,1}$  caused by non-zero blade thickness at the leading edge and to allow for higher flow rates that may be called for at off-design conditions. To construct the triangle, one first plots  $U_1$  and then  $V_{m,1}$ , which is taken from an analysis such as that of Figure 14 (altered as noted previously for the effect of the blades) or is chosen as the mean value  $Q/2\pi r_{b,1}b_1$  (Figure 13) at the rms streamline. It is adjusted from experience at the shroud and hub. Likewise, if any prewhirl  $V_{\theta,1}$  is delivered to the impeller, it must be taken into account as illustrated in Figure 3.

- iv. *Outlet blade angles.* Whereas the inlet velocity diagrams enable the designer to correctly set the blades to receive the incoming fluid with minimum loss, the outlet velocity diagram displays the evidence—through the magnitude of the circumferential velocity component  $V_{\theta,2}$  that the intended head will be delivered by the pump in accordance with Eq. 15c. As shown in Figure 3,  $V_{\theta,2}$  is determined—for the given impeller tip speed  $U_2$ —by the exit relative flow angle  $\beta_{f,2}$  in conjunction with the exit meridional velocity component  $V_{m,2}$ . This value of  $V_m$  is somewhat larger than that given by Eq. 16 because of a) blockage due to blade thickness and boundary layer displacement thickness and b) the presence of any leakage flow  $Q_L$  (Figure 2 and Eq. 11) that may also be flowing through the impeller exit plane or Station 2.

Well inward of the exit plane, the direction of the one-dimensional relative velocity vector  $W$  can be assumed to be parallel to the blade surface; however, in the last third

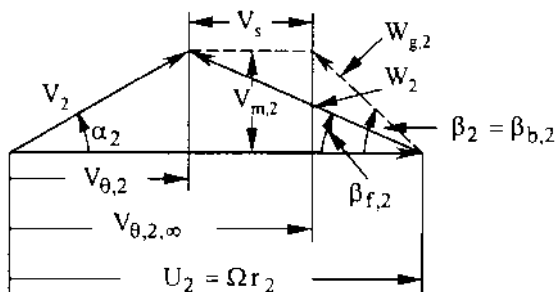


FIGURE 15 Impeller outlet velocity diagram

of the passage, the blade-to-blade distribution of the local relative velocity changes due to the unloading of the blades at the exit. This produces a deviation of the direction of  $W_2$  from that of the blade. This deviation, called "slip" in pumps, results in less energy being delivered to the fluid by the impeller than would be the case if there were "perfect guidance" such as would occur with an infinite number of blades. Accordingly, in the outlet velocity diagram of Figure 15, the relative flow angle  $\beta_f$  is less than the blade angle  $\beta_b$ . This deviation is quantified by the "slip velocity"  $V_s$ . The magnitude of  $V_s$  depends on the distribution of loading along the blades from inlet to exit and therefore on the geometry of the flow passages and the number of blades. (Without slip,  $W_2$  is the same as the "geometric" relative velocity  $W_{g,2}$  shown in the figure.) The slip factor  $\mu = V_s/U_2$ —typically between 0.1 and 0.2—was determined theoretically by Busemann for frictionless flow through impellers with logarithmic-spiral blades (constant- $\beta$  from inlet to exit) and a two-dimensional, radial-flow geometry with parallel hub and shroud<sup>18</sup>. Applicability of this theory to typical impellers, despite the differences in geometry and the real fluid effects, was found to be good by Wiesner, who represented Busemann's results by the following convenient approximation<sup>19</sup>:

$$\mu \equiv \frac{V_s}{U_2} = \frac{\sqrt{\sin \beta_2}}{n_b^{0.7}} \quad (52)$$

A broader, empirical slip correlation for pumps was developed by Pfeleiderer, taking into account impeller geometry and blade loading, as well as the influence of the downstream collecting system (volute or diffuser)<sup>20</sup>. Pfeleiderer computes the slip velocity as the product of a slip factor  $p$  and the impeller exit tangential velocity  $V_{\theta,2}$ , where  $p$  is computed as shown in Table 2. This table also contains a simple example; namely, a radial flow impeller of a volute pump, for which the resulting value of  $\mu$  is 0.1826—versus 0.1498 via Eq. 52; however, in this case the latter result is low by about 15 percent. A study of the Busemann plots in Wiesner's paper yields  $\mu = 0.18$ . Yet, if this had been a vaned-diffuser pump, Pfeleiderer would have predicted  $\mu = 0.1468$  for the same impeller, as it would have delivered more  $V_{\theta,2}$  for the same  $\beta_{b,2}$ ,  $W_{g,2}$ , and, therefore,  $V_{\theta,2}$ , (Figure 15). This stems from the factor "a" in Table 2 having the value 0.6 (for a vaned diffuser) instead of 0.8 (for a volute). So by this combination of circumstances—and in this example—Eq. 52 describes the slip of a diffuser pump impeller. But, despite the simplicity of Eq. 52, Pfeleiderer's method (Table 2) would appear to be a more rational, comprehensive, and satisfying method for estimating slip in real pumps.

So, to find the outlet blade angle, the designer begins by deciding upon the required value of  $V_{\theta,2}$ ; finds the exit flow angle and other elements of the diagram assuming the existence of slip. Next, the designer computes the slip and then obtains the value of the outlet blade angle  $\beta_{b,2}$ . The process is iterative because the forementioned blockage depends on the blade angle as well as the thickness.

**TABLE 2** Pfleiderer's slip formula

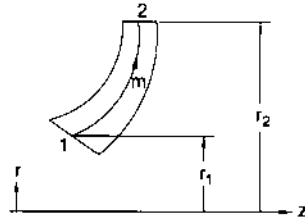
Slip Velocity  $V_s$ :

$$V_s = p V_{\theta,2}$$

$$\left[ \Rightarrow \frac{V_{\theta,z,2}}{V_{\theta,2}} = 1 + p \right]$$

where

$$p = \frac{\psi' r_2^2}{z \int_1^2 r \, dm}$$



and where  $\psi' = a \times (1 + \sin \beta_2)$   
 (or  $\beta_{b,2}$ )

and a =  $\begin{cases} 0.6 \text{ Diffuser (vaned)} \\ 0.65 - 0.85 \text{ Volute} \\ 0.85 - 1.0 \text{ Vaneless diffuser} \end{cases}$

$$\left\{ \begin{aligned} \Rightarrow \int_1^2 r \, dm &= \frac{1}{2} (r_2^2 - r_1^2) \\ &= \left( \frac{r_2 + r_1}{2} \right) \times (r_2 - r_1) \end{aligned} \right.$$

Example:  $r_2 = 1$  ;  $r_1 = 0.4$  ;  $V_{\theta,2} = \frac{U_2}{2}$  ;

$$\left\{ \begin{aligned} p &= \frac{V_s}{V_{\theta,2}} = \frac{0.8 \times (1 + 0.342) \times 1^2}{7 \times \frac{1 + 0.4}{2} \times 0.6} = 0.3652 \\ \mu &= \frac{V_s}{U_2} = p \times \frac{V_{\theta,2}}{U_2} = 0.3652 \times \frac{1}{2} = 0.1826 \end{aligned} \right.$$

v. *Number of blades.* The choice of the number of impeller blades is influenced by a) interaction of the flow and pressure fields of the impeller and adjacent vaned structures such as the volute tongues or diffuser vanes and b) the need to maintain smooth, attached—and therefore efficient—fluid flow within the impeller passages. The effect of the number of blades on the interaction phenomenon is addressed in the latter part of this section under the topic of high-energy pumps, where this issue becomes critical. Smooth, attached flow is assured if the product of the number of blades and their total arc length  $\ell$  along a given meridional streamline, as illustrated in Figure 16, is of sufficient magnitude. Divided by a representative circumference on that streamline, usually that of the impeller outer diameter (OD), this product is called the solidity  $\sigma$ :

$$\sigma = \frac{n_b \times \ell}{2\pi r_2} \tag{53}$$

In practice, solidity varies from about 1.8 at low specific speed ( $\Omega_s < 0.4$  or  $N_s < 1093$ ) to slightly less than unity at  $\Omega_s = 3$  ( $N_s = 8199$ ). For example, Dicomas' curve<sup>21</sup> is



$V_{m,o}$  is the local meridional velocity component neglecting blockage. (One-dimensionally,  $V_{m,o}$  is the value of  $V_m$  found from Eq. 16, where the radius  $r$  is that from the axis of rotation to the center of the circle of diameter  $b$  in Figure 8, which in turn lies on an imaginary line in Figure 8 that is normal to the hub, shroud, and intermediate stream surfaces.) Here,  $\Delta W_b$  emerges by applying Bernoulli's equation [Eq. 21 with no change in radius (that is, no change in  $U$ ) or loss as one traverses from pressure side to suction side of the passage] to the static pressure difference  $p_p - p_s$  arising from the delivery of angular momentum to the fluid (Eq. 26). This in turn results from the application of the shaft torque to the blades. It is also assumed in the derivation of Eq. 54 that the *blade-to-blade average relative velocity  $W$  lies halfway between the surface velocities  $W_s$  and  $W_p$* , (which would exist just outside the boundary layers on the blades,) as illustrated in Figure 17. This is a good assumption for efficient flow well within a bladed channel<sup>22</sup>.  $\Delta W_b$  is inversely proportional to the solidity because, on the average, from inlet to outlet, Eq. 54 becomes

$$\overline{W_s - W_p} = \overline{\Delta W_b} \approx \left( \frac{2\pi r_2 \sin \beta}{n_b \Delta m} \right) \Delta \left( \frac{r}{r_2} V_\theta \right) \quad (55)$$

where it can be seen from Figure 16 and Eq. 53 that the fraction involving the number of blades  $n_b$  is the reciprocal of the solidity  $\sigma$  because

$$\ell = \Delta m / \overline{\sin \beta} \quad (56)$$

For unconventional impeller geometries, the foregoing solidity guidelines may be inadequate to assure efficient flow. For any geometry, though, the concept of a diffusion factor  $D$ , utilized by NACA researchers<sup>23</sup> to assess stationary cascades of airfoils can be employed. In view of Eqs. 53–56, their equation for  $D$  takes the following form for both axial- and non-axial-flow geometries, rotating or not:

$$D = 1 - \frac{W_2}{W_1} + \frac{\Delta \left( \frac{r}{r_2} V_\theta \right)}{2\sigma W_1} \quad (57)$$

This can be deduced from Figure 17 as follows:

$$D = \frac{W_1 - W_2}{W_1} + \frac{\overline{\Delta W_b}}{2W_1} \left( \approx \frac{\Delta W_{\text{diffusion}}}{W_1} \right) \quad (58)$$

Then, Eq. 57 is obtained through the definitions of the average value of  $\Delta W_b$  (Eq. 55 with Eq. 56) and  $\sigma$  (Eq. 53). NACA researchers found that losses increase rapidly if  $D > 0.6$ . However, many centrifugal pump impellers have virtually the same value of relative velocity  $W$  at in and at outlet—along the rms streamline (Figure 17), so  $D$  from Eq. 57 is less than 0.6 on the rms streamline and even negative along the hub streamline. This situation was encountered in accelerating (turbine) cascades and led to the use of local diffusion factors, one for each side of the blade, namely  $D_p$  and  $D_s$ . Here, inspection of Figure 17 and Eq. 58 leads to

$$D_p = 1 - \frac{W_{p,\min}}{W_1} \quad ; \quad D_s = 1 - \frac{W_2}{W_{s,\max}} \quad (59a \text{ and } b)$$

where the 0.6 limit applies individually to  $D_p$  and  $D_s$ —or to the sum of the two, in which case the limit is 1.2. Eqs. 59a and 59b, therefore, constitute a more useful form

of the diffusion factor concept for assessing the blade loading and the choice of the number of blades in centrifugal pump impellers<sup>24</sup>.

Finally, the total blade length or number of blades, should not exceed that necessary to limit the diffusion as just described, as this adds unnecessary skin friction drag, which causes a reduction in efficiency. Thus the solidity values given in conjunction with Eq. 53 should not be appreciably exceeded, unless blade load needs to be reduced to lower levels, as with inducers to limit cavitation<sup>8</sup> or impellers for pumps that must produce lower levels of pressure pulsations.

- vi. *Development of the blade shape.* Blades are developed by defining the intersection of the mean blade surface (really an imaginary surface) or camber line on one or more nested surfaces of revolution. Two such surfaces are formed by the hub and shroud profiles. If the blade shape is two-dimensional (that is, the same shape at all axial positions  $z$ ), the mean blade surface is completely defined by constructing it on only one such surface of revolution. Generally, however, the shape is three-dimensional and is a fit to the shapes constructed on two or more of these surfaces of revolution; namely, the hub and shroud and usually at least one surface between them. After this final shape is known, half of the blade thickness is added to each side. (Sometimes the full blade thickness is added to one side only, meaning that the constructed surface just mentioned ends up—usually—as the pressure side of the finished blade rather than the mean or “camber” surface. The effective blade angles are then slightly different from those of the pressure side used in the construction process.) The construction along a mean surface of revolution is illustrated in Figure 18. The distribution of the local blade angle  $\beta$  (or more precisely,  $\beta_b$ ) is found first by either the “point-by-point” method or the *conformal transformation* method—both of which yield the polar coordinates of the blade,  $r$ ,  $\theta$ , and  $z$ . These coordinates also depend on the chosen shapes of the intersections of the surfaces of revolution with the meridional plane; that is, the hub, shroud, and mean meridional “streamline” or rms line, as in Figure 18c, and the fact that, on the surface of revolution Figure 18a,  $\tan \beta = \text{arc } bc / \text{arc } ac = dm / dy$ . The elemental tangential length  $dy$  ( $= \text{arc } ac$ ) is the same on both the surface of revolution (Figure 18a) and in the polar view (Figure 18b). From Figure 18b, it is seen that  $dy = r d\theta$ , so the “wrap” angle  $\theta$  is found from

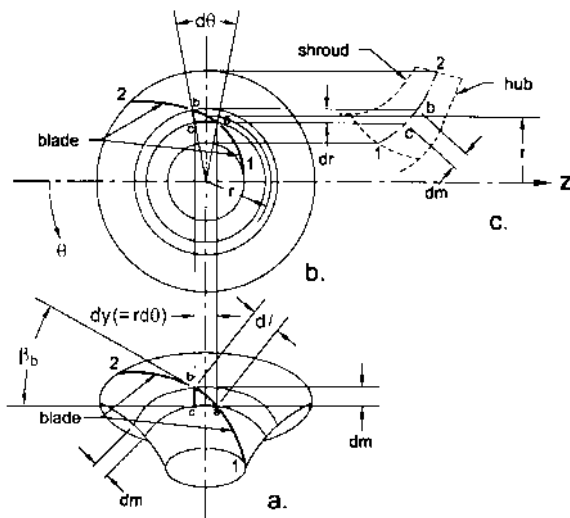


FIGURE 18 Blade construction: a) view of construction surface of revolution; b) polar view; c) meridional view



$$\tan \beta_b = \frac{dm}{rd\theta} \quad (60)$$

and  $r$  and  $z$  are found from the fact that the coordinate  $m$  along each of the construction surfaces is a function of  $r$  and  $z$  (Figure 18c).

If the blade is two-dimensional, its mean surface consists of a series of straight-line axial elements, each having a unique  $r$  and  $\theta$  at all  $z$ . Such a blade is typical of low-specific-speed, radial-flow impellers, and can be easily constructed by the “point-by-point” method. Here, one specifies the distribution of  $W_g$ —often linear as in Figure 17—after determining the hub and shroud profiles and the corresponding distribution of  $V_m$ <sup>15</sup>. In effect, one obtains the distribution of the blade angle  $\beta_b$  by constructing a velocity diagram like the one in Figure 15 at every  $m$ -location from inlet (1) to outlet (2) in Figure 18c, dealing only with the “geometric” or non-deviated velocities, in order to get a smooth variation of the blade angle  $\beta_b$  vs  $m$ . Allowance is made for blockage due to the thickness of the blades and the displacement thickness of the boundary layers in the passage. The resulting wrap angle  $\theta$  for each  $m$ -point—as well as the corresponding  $r$  and  $z$ —is then found from Eq. 60. (For convenience in designing the blades, the construction angle  $\theta$  is often taken as positive as one advances from impeller inlet to exit. For most impellers, this turns out to be opposite to the direction of rotation; and  $\theta$  is taken in the direction of rotation for most other purposes of pump design and analysis.) As discussed previously in Paragraph iv and illustrated in Figure 17, the actual flow will deviate from the resulting blade via the “slip” phenomenon.

The point-by-point method allows the designer to exercise control over the relative velocity distributions on the blade surfaces (Eq. 54 and Figure 17) via specification of the distribution of  $W_g$  or other velocity component in Figure 15; for example,  $V_\theta$ . This becomes more important if an unconventional impeller geometry is being developed<sup>17</sup>.

The point-by-point method can also be used for three-dimensional blades. A simple approach in this respect would be to use this method to determine the blade shape along the rms- or 50%-streamline (that is, on the mean surface of revolution depicted in Figure 18). The shapes on the other streamlines, generally the hub and the shroud, can also be found by this method. The resulting overall blade shape, however, is subject to the condition that the resulting wrap  $\theta_2 - \theta_1$  cannot greatly differ on all streamlines without the blade taking on a shape that is difficult to manufacture and which may turn out to be structurally unsound or create additional flow losses. This is because the final blade shape is the result of stacking the shapes that have been established on the nested stream surfaces defined by these meridional streamlines. Blade forces due to twists arising from this stacking could modify the expected flow and cause unexpected diffusion losses.

One way to generate blade shapes along the hub and shroud that have the same (or nearly the same) wrap as that obtained from point-by-point construction of the blade on the mean surface of revolution is to establish the desired inlet and outlet blade angles  $\beta_b$  on each such surface and then mathematically fit a smooth shape  $y(m)$  to these end and wrap conditions, where  $y$  is the tangential coordinate seen in Figure 18 and defined in Figure 19. A conformal representation of the shapes of the blades resulting from such a procedure on each of the three surfaces is seen in Figure 19. These shapes are sometimes called “grid-lines” or simply “grids”—from the description of the graphical procedure that relates these shapes in the conformal representation to those on the actual, physical surfaces<sup>4</sup>. In such a representation, the blade angles are the same as they are on the physical surface of revolution because  $\tan \beta = dm/dy$  and  $dy = rd\theta$ , also yielding Eq. 60.

If the associated distributions of  $W_g$  and  $V_m$  are smooth, one can expect to have a satisfactory result if these conformal representations are also smooth. Thus, many skilled designers bypass the computations just described for the point-by-point method and use the *conformal transformation* method of blade design. Here, one simply establishes the grid-line shapes by eye in the conformal plane of Figure 19, specifying the blade angles  $\beta$  at inlet and outlet by the previous procedures as the starting point for

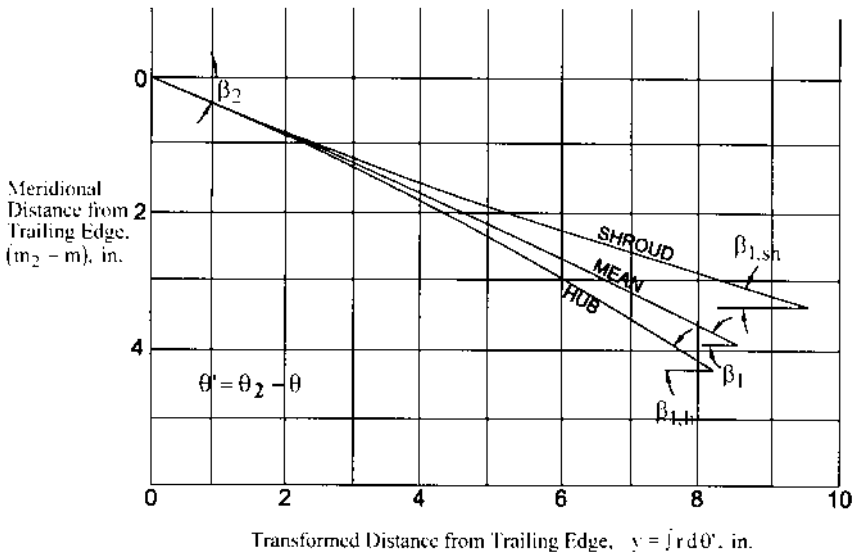


FIGURE 19 Conformal transformation of blade shape: "grid-lines"

drawing each grid-line. This conformal blade shape is then transformed onto the physical surface, the differential tangential distance  $dy$  becoming  $r d\theta$  on the physical surface (Figure 18) and the differential meridional distance  $dm$  being identical in both the conformal and physical representations. If the resulting blade shape appears to be unsatisfactory, the designer repeats this process, possibly first altering the hub and shroud profiles or the blade leading and trailing edge locations on these profiles and recomputing the  $\beta$ 's.

**Designing the Collector** The fluid emerging from the impeller is conducted to the pump discharge port or entry to another stage by the collecting configuration, which can employ one or more of the following elements in combination: a) *volute*s, which can be used for designs of all specific speeds, b) *diffuser* or *stator vanes*, which are often more economical of space in high-specific-speed single-stage pumps and in multistage pumps, and for the latter, c) *return* or *crossover passages*, which bring the fluid from the volute or diffuser to the eye of the next-stage impeller. Generally, the most efficient impeller has a steady internal relative flow field as it rotates in proximity to these configurations. This is assured by all of these elements because they are designed to maintain uniform static pressure around the impeller periphery—at least at the design point or BEP. An exception to this rule is the concentric, "doughnut"-type, "circular-volute" collector, which is used on small pumps or in special instances where the uniform pressure condition is desired at zero flow rate.

The proximity of stationary vanes in these collecting configurations to the impeller must be considered in their design. Called "Gap B," the meridional clearance between the exit of the impeller blades and adjacent vanes ranges from 4 to 15 percent of the impeller radius, volutes having higher values in this range than diffusers, and pumps of higher energy level requiring the larger values. If these gaps are too small, the interactions of the pressure fields of the adjacent blade and vane rows passing each other can cause vibration and structural failure of impeller blades, diffuser vanes, and volute tongues.

a) *Volute*s. A volute is built by distributing its cross-sectional area on a "base circle" that touches the tongue or "cutwater" and is meridionally removed from the impeller exit by

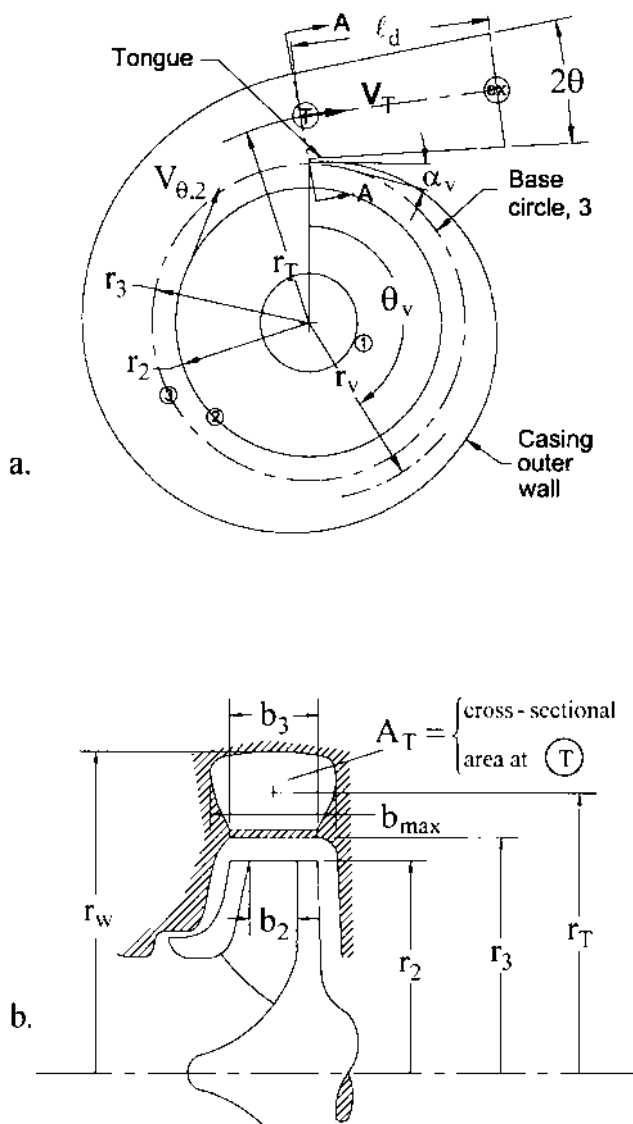


FIGURE 20 Volute casing: a) polar view; b) meridional view including Section A-A of throat T

Gap B. (For radial-discharge impellers, as in Figure 20, this is a radial gap, and the base circle has radius  $r_3$ .) Beginning at the tongue, the cross-sectional area  $A_\theta$  of the volute passage is zero, but it increases with angle  $\theta$  in the direction of rotation, ending up at area  $A_T$  in the "throat" T, as depicted in Figure 20. Worster demonstrated that the desired peripheral uniformity of static pressure can be achieved if the product  $rV_\theta$  is constant

everywhere in the volute<sup>25</sup>. One-dimensionally, this means that  $r_T V_{\theta T} = r_2 V_{\theta 2}$ ; and, if the velocity  $V_T$  is essentially tangential (in the  $\theta$ -direction),  $r_T V_T \cong r_2 V_{\theta 2}$ . The diffusion or reduction of the velocity  $V$  from the impeller periphery at  $r_2$  to the larger  $r_T$  of the throat produces a static pressure increase above that at the impeller exit; however, friction losses in the volute would cause a reduction in static pressure around the impeller at  $r_2$  from tongue to throat unless the throat area  $A_T = Q/V_T$  is slightly enlarged, creating a little more diffusion to compensate for this loss. Thus, in practice, at the BEP,

$$r_T V_T \cong (0.9 \text{ to } 0.95) \times r_2 V_{\theta 2} \quad (61)$$

At off-BEP conditions, the volute will be either too large or too small and Eq. 61 will not be satisfied. When the flow coefficient (or  $Q/N$ ) drops below the BEP value, there will be excessive diffusion and an increase of static pressure around the volute from the zero area point around to the maximum area point at the throat. Proceeding around further, past the throat, a sudden drop in pressure occurs across the tongue to bring the pressure back to what it was at the starting point<sup>25</sup>. The opposite situation occurs above BEP.

Each of these off-BEP circumferential static pressure distributions is properly viewed as the consequence of a mismatch between the head-versus-flow characteristics of the impeller and volute<sup>26</sup>. For the impeller, there is the falling, straight,  $H_i$ -versus- $Q$  line or “impeller line” of Figure 6, whereas the volute characteristic or “casing line” would be a straight line starting at the origin of Figure 6 and crossing the impeller line at the match point, which is generally at or close to the BEP flow rate. This casing line is straight because the throat velocity  $V_T$  varies directly with flow rate  $Q$  and, through Eq. 61, directly with the ideal head  $H_i$ —because  $\Omega \times r_2 V_{\theta 2} = H_i$  (Eq. 15b for  $V_{\theta 1} = 0$ ). In other words, the same volute could be optimum at a different value of  $Q$  if it were paired with another impeller whose  $H_i$ -versus- $Q$  line crossed this same casing line at that different  $Q$ .

To essentially eliminate the consequent radial thrust on the impellers of large pumps at off-BEP conditions, a double volute is used; that is, there are two throats, 180 degrees apart, there being either two discharge ports or a connecting “back channel” to carry the fluid from one of the throats around to join the flow emerging from the other—to form a single discharge port.

The value of the volute cross-sectional area  $A_v$  at a given polar position  $\theta_v$  can be found for the portion of the total pump flow rate  $Q$  being carried in the volute at that  $\theta_v$ -position together with the condition  $rV_\theta = \text{constant}$  versus radius. This will produce a distribution  $A_v(\theta)$  that is slightly below a straight-line variation versus  $\theta_v$  from zero to  $A_T$ . Often, the practice is to use the latter straight-line design because this produces larger values of  $A_v$  where the hydraulic radius of the volute is small, thus compensating for the greater friction loss in that region through lower velocity—particularly for the smaller pump sizes. The cross-sectional shape of the volute is dictated by the need to make a minimum-loss transition from a small area at the beginning of the volute where the height (as can be deduced from Figure 20b) is much smaller than the width  $b_3$  to the throat, for which the height (to the outer casing wall at  $r_w$ ) and the width  $b_{\max}$  are more nearly equal. Too small an aspect ratio (height/width) decreases the hydraulic diameter too much and increases the loss. There is another transition from the throat through an essentially conical diffuser (which may negotiate a turn) to a larger, circular exit port. This diffuser can be designed with the help of charts of flow elements and will normally have a 7-deg. angle of divergence and a discharge area up to twice that of the throat  $A_T$ <sup>27</sup>. Thus, there is a substantial diffusion from the impeller periphery to the pump or stage exit port. This generally produces a static pressure rise in the collection system that is 20 to 25 percent of that of the whole stage.

*b) Vaned diffusers.* A vaned diffuser is rotationally symmetric and, if properly applied, produces minimal radial thrust over the whole flow rate range of a pump. Although diffusion can be accomplished in a radial outflow configuration without vanes due to the essential constancy of the angular momentum per unit mass  $rV_\theta$ , one rarely finds a pump with a vaneless diffuser, partly because so much radial distance is needed to effect the reduction of tangential velocity required, as well as the still larger volute needed on single-stage

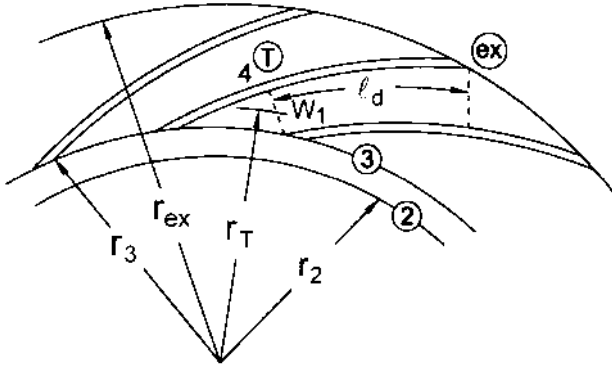


FIGURE 21 Vaned diffuser

pumps to collect the fluid at the exit of such a diffuser. Also, the absolute flow angle  $\alpha_2$  (Figure 15) of the fluid leaving the impeller is usually too small to satisfy the conditions for stall-free flow in a vaneless diffuser<sup>28</sup>. A vaned diffuser, on the other hand, can accomplish the reduction of velocity in a shorter radial distance. Also it can diffuse axially and, to a degree, even with radially inward flow.

Vaned diffusers are similar to multiple volutes in concept, except they are subject to off-design flow instabilities if not shaped correctly. Width  $b_3$  is usually slightly greater than  $b_2$  in order to accommodate discrepancies in the axial positions of impellers that feed them. With reference to Figure 21, "Gap B" ( $= r_3 - r_2$ ) is in effect a short vaneless diffuser, and by the time the fluid has reached the throat (the dashed line at Station 4), it has gained a substantial portion of the static pressure recovery that takes place via diffusion from Station 2 to Station "ex." This "pre-diffusion" is enhanced by the fact that the throat area at Station 4 ( $= b_3 w_1$  per passage for parallel-walled radial-flow diffusers) is larger than it is for volutes, the following relation applying to diffusers<sup>29</sup>:

$$r_T V_T \cong 0.8 r_2 V_{\theta, 2} \quad (62)$$

Therefore, more diffusion than would result from applying Eq. 61 occurs in a vaned diffuser, the skin friction loss due to an otherwise higher velocity at the throat being offset by an efficient reduction of the velocity up to that point and a lower velocity onward.

The fully vanned portion from throat to exit (Figure 21), which performs most of the rest of the diffusion and associated static pressure recovery of the stage, is designed to perform efficiently and maintain stable flow. For typical radial-flow geometries with parallel walls, the vanes can be of constant thickness and comparatively thin or can thicken up to form "islands." The latter approach usually produces a channel that is two-dimensional with straight sides diverging at an included angle, length-to-entrance width  $\ell/w_1$ , and area ratio  $A_{ex}/A_T$  in a combination that avoids appreciable stall<sup>30</sup>. A typical combination is an included angle of  $11\frac{1}{2}$  deg.,  $\ell/w_1 = 4$ , and  $A_{ex}/A_T = 1.8$ , which also applies for vanes of constant thickness, as illustrated in Figure 21. Constant thickness vanes have curvature. This modifies the performance somewhat<sup>31,32</sup>, but it allows a smaller overall radius ratio of the diffuser,  $r_{ex}/r_3$ .

Also, this ratio  $r_{ex}/r_3$  will be smaller as the number of vanes  $n_v$  increases. The best experience seems to be with diffusers that have only a few more vanes than the number of impeller blades  $n_b$  ( $n_b$  rarely exceeds 7 in traditional commercial pumps). For pumps of higher energy levels (or high head per stage, as discussed further on in connection with high-energy pumps), it is important that  $n_v$  be chosen so as to avoid a difference of 0 or 1 between  $n_b$  and  $n_v$ , or their multiples—up to at least the third multiple or "order" of each. A difference of 2 should also be avoided for at least the lower orders<sup>33</sup>.

At off-design flow-coefficients (or off-design flow rate at a constant speed), the angle  $\alpha$  of the absolute velocity vector  $V$  (Figure 15) approaching the diffuser will vary; yet, for typ-

ical stages, a wide range of flow coefficient is possible without damaging instabilities, even at high energy levels. This is likely the case because  $\alpha$  is rather small at the design point or BEP (except for designs having high specific speed), so variations of the angle that occur with flow changes are within the unstalled performance range of the diffuser vane system.

*c) Return passages.* Conducting the relatively low-velocity fluid from the diffuser to the eye of the next impeller in a multistage pump is accomplished with return vanes or passages that also deswirl the fluid wholly or partially. Except for development of stall in the diffuser, these passages will not see a changing angle of the approaching velocity vector because the diffuser feeding them is a stationary element. In radial-flow pumps, there is a sharp turn in the meridional plane in order to redirect the fluid inward. The fluid, still possessing a circumferential component of velocity that is greater than the meridional component, actually sees a much gentler turn. However, downstream of this point, a sharp turn of the blades is invariably a feature of a return passage; and this, together with the need to ensure undistorted flow into the following impeller, often dictates that the vane system accelerate the fluid as it approaches the eye. Although losses in the return passages—being related to the low velocity within them—have a minor effect on the overall stage efficiency, the design of such passages must ensure unstalled flow into the impeller in order to avoid the negative impact of a distorted inlet flow on the efficiency and to promote pulsation-free operation of the impeller.

A variety of return-passage geometries exist, some of which are presented in the literature<sup>29,34</sup>. The continuous-vane type is integral with the upstream diffuser, thereby eliminating the entry losses into yet another vane system after the diffuser<sup>4,34</sup>. Improvements in manufacturing technology have made this potentially more efficient approach more viable for radial machinery. The continuous-vane concept is standard practice in the design of mixed-flow “bowl”-type pumps<sup>21</sup>. The diffusing stator vane row that receives the fluid from the impeller of an axial-flow pump—being an axial-flow element itself—possesses the return feature already. Diffusion in axial-flow stators is typically accomplished by a reduction in velocity of about 30 to 40 percent. The actual value is governed by an acceptable level of the diffusion factor, Eq. 57. (A similar reduction in relative velocity is needed for an axial-flow impeller to generate static pressure, as can be seen from Eq. 21. By comparison, centrifugal impellers, on the rms streamline, usually have  $W_2$  about equal to  $W_1$ —as seen in Figure 17.)

**Axial-Flow Pumps** The preceding development, though general, is applicable mainly to centrifugal and mixed-flow pumps. In that procedure, the impellers have appreciable solidity, and original blade shapes are constructed from the viewpoint of one- or two-dimensional channel flow. The collectors are often volutes or non-axial-flow vane systems. Performance is not known a priori and so must be estimated, as outlined further on. On the other hand, the extensive two-dimensional, experimental, axial-flow cascade data amassed by NACA researchers<sup>23</sup> and others enables the designer to adopt existing airfoil blade shapes and so predict the performance with greater confidence. The procedure for utilizing these shapes and the corresponding experimental results has long been the basis for designing axial-flow compressors for gas-turbine engines and is clearly described by Hill and Peterson<sup>35</sup>. This approach is widely used, especially for high-specific-speed, low-solidity axial-flow propeller pumps—in designing both rotating and stationary blade rows. Insights for propeller pump design and performance characteristics can be found in Stepanoff<sup>1</sup>.

An exception to this axial-flow pump design approach is the case of inducers. Although they are axial flow pumps, they have high solidity and are usually designed as channel-flow machines. The design philosophy outlined in the preceding paragraphs is applicable, except that the blades usually approximate constant- or variable-pitch helices. Performance prediction is generally accomplished via one-dimensional calculations and the correlations described in the following paragraphs.

## PREDICTING THE PERFORMANCE CURVES

---

The choices made in the foregoing design procedures can and should be verified analytically, the objectives being first to generate the performance characteristic curves for head

and power at constant speed and second to ensure stable behavior of the various systems in which the pump is to be applied. For the first objective, the solution involves analytical or empirical approaches: a) at non-recirculating flow conditions; that is, from flow rates  $Q$  somewhat below  $Q_{\text{BEP}}$  out to the maximum “runout” flow rate, b) at shut-off ( $Q = 0$ ) and low flow, or c) the complete set of curves for a given pump predicted by means of computational fluid dynamics (CFD).

**Generating Performance Curves** The fluid dynamical limitation on the deceleration of the relative velocity  $W$  determines the shape of the head-versus-flow curves. This is inherent in the choice made for the head coefficient  $\psi$  in Figure 12, which sizes the impeller and is illustrated in Figure 22. The typical situation of zero (or nearly so) inlet whirl  $V_{\theta,1} = 0$  means that the ideal head coefficient  $\psi_i$  equals the most significant ratio of the outlet velocity diagram because from Eqs. 15 and 31 (with for  $V_{\theta,1} = 0$ ):

$$\psi_{\text{ideal}} = \frac{\mathcal{E}_2^2 (V_{\theta,2}/U_2)}{\mathcal{E}_2^2} \quad (63)$$

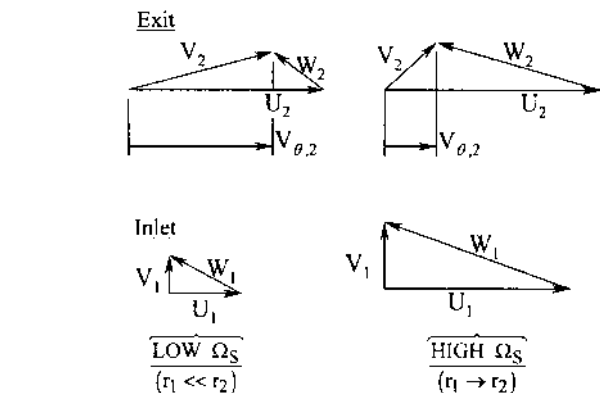
$$\psi = \eta_{HY} \psi_{\text{ideal}} = \eta_{HY} \frac{V_{\theta,2}}{U_2} \quad (64)$$

Figure 22 illustrates how specific speed  $\Omega_s$  affects the BEP value of  $\psi_i$  and therefore  $\psi$ . Overall, only a small reduction of  $W$  occurs in most impellers. So, at low  $\Omega_s$ , the low value of  $W_i$  associated with the small eye relative to the maximum diameter (Figure 9) enables the outlet velocity diagram (Figure 22a) to have a high value of  $V_{\theta,2}/U_2$ . On the other hand, this ratio drops as  $\Omega_s$  increases and the eye grows to be as large as the maximum diameter of the wheel. Figure 22b is the result because the value of  $\psi$  at shut-off (about  $\frac{1}{2}$ ) is not based on the one-dimensional concept of velocity diagrams but primarily on the pressure generated by solid body rotation of stalled (though recirculating) fluid contained within the impeller. The BEP values of  $\psi$  in Figure 22b are consistent with Figure 12 and illustrate why a high-specific-speed impeller has such a substantial “rise to shut-off” of the head curve. This is dramatically illustrated in Figures 8–10 of Section 2.3.1 in which the head curves are normalized to that of the BEP<sup>36</sup>.

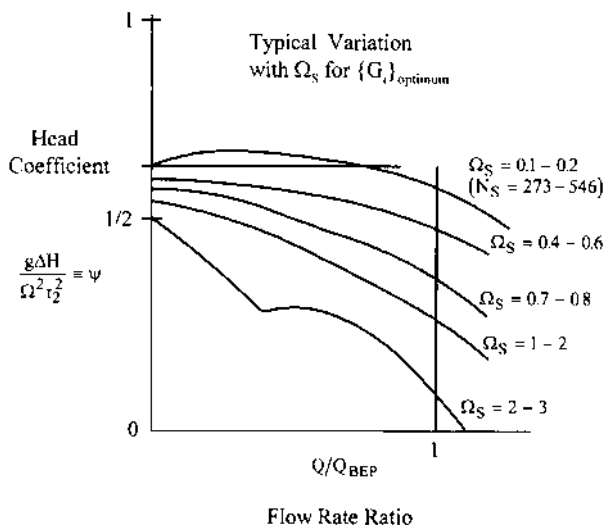
*a) Non-recirculating flows.* The BEP efficiency and head can be determined from correlations for typical pumps or from computation of the losses. Fluid dynamic procedures described in this section can be used to determine the shapes of the head and power curves at all flow rates to runout, using the BEP as an anchor point for such computations. For pumps designed conventionally, beginning with Figure 12, Anderson’s overall (BEP) efficiency correlation (Eq. 44) as modified in Figure 10 is useful. Other similar charts, especially Figure 6 in Section 2.3.1, are in widespread use. The breakdown of the losses involved, as expressed by Eqs. 8–11, is quantified through the development of the three component efficiencies  $\eta_{HY}$ ,  $\eta_m$ , and  $\eta_v$  in Table 3. All three decrease with decreasing specific speed—as might be expected from the charts just mentioned.

This can be seen in the  $\eta_{HY}$ -expression (a) of Table 3 because  $\psi_i$  is greater at low  $\Omega_s$  as discussed relative to Figure 22. Jekat’s  $\eta_{HY}$ -expression (b) of the table works surprisingly well, largely because of the flow effect in Figure 9 (explained there as the “size effect” of larger relative roughness and clearances in smaller pumps) and because low  $\Omega_s$  tends to go hand-in-hand with low flow rate  $Q$ .

To compute  $\eta_{HY}$  at  $Q \neq Q_{\text{BEP}}$  (and, if required, at  $Q = Q_{\text{BEP}}$  as well), it is necessary to go deeper into the prediction of  $\eta_{HY}$  by developing *expressions for the losses* noted in Eq. 21, which are basically expansions of the expression for the collector loss coefficient  $\zeta_c$ <sup>26</sup> and for the impeller loss expression (c) of Table 3<sup>37</sup>. In this expression, the incidence loss coefficient  $k$  can be obtained from cascade data or developed as a combination of a turning and a sudden expansion loss<sup>4,8,27</sup>. The “pipe-type friction factor”  $f$  can be increased to include secondary flow and diffusion losses due to blade loading (or turning<sup>38</sup> of the absolute velocity vector  $V$ ). The resulting  $f$ -value can thus be twice the usual pipe value associated with the skin friction losses in the passage. (The pipe value of  $f$  is found from the well-known



a) velocity diagrams at BEP



b) head-vs-flow curves

FIGURE 22 Performance versus specific speed: a) velocity diagrams at BEP; b) head-versus flow curves.

pipe friction chart—Figure 31 in Section 8.1—by substituting a representative average passage hydraulic diameter  $D_h = 4A_p / \wp$  for the pipe diameter ( $d$ ). A further increase in this  $f$ -value occurs if the impeller is missing one or both rotating shrouds; that is, it is a semi- or fully-open impeller with blade tip leakage losses appearing in the main flow stream<sup>39</sup>. Multiphase flows in pumps often are accompanied by greater than normal hydraulic losses; for example, increasing the concentration of solids in the carrier liquid flowing through a slurry pump increases the  $f$ -value still further<sup>40</sup> (see Section 9.16.2).



*Quasi three-dimensional (Q3D) analysis*<sup>41</sup> affords an assessment of the secondary flow and diffusion losses and gives results similar to inviscid three-dimensional (3D) flow analysis. Q3D analysis starts by solving the 2D meridional (hub-to-shroud) flow field—as in Figure 14, but with blades present. This is followed by a series of 2D blade-to-blade

**TABLE 3** Component efficiency expressions developed

A) Hydraulic Efficiency

Breaking up the main flow losses into impeller (including inlet)

and collector losses  $\sum_i L_i = L_{\text{imp}} + L_c$  and defining  $L_c = \zeta_c \frac{V_2^2}{2}$ , where  $\zeta_c$

is the collector loss coefficient or fraction of  $V_2^2/2$  not converted into static pressure rise in the collector, we have (Eq. 10)

$$\eta_{\text{HY}} = 1 - \frac{\sum L_i}{\Delta(UV_\theta)} = 1 - \underbrace{\frac{L_{\text{imp}}}{\Delta(UV_\theta)}}_{\eta_I} - \underbrace{\frac{\zeta_c V_2^2/2}{\Delta(UV_\theta)}}_{\zeta_c \left( \frac{\psi_{i,2}}{2} + \frac{\phi_{i,2}^2}{2\psi_{i,2}} \right)}$$

or, for no inlet whirl ( $V_{\theta,1}=0$ )  $\psi_i = \psi_{i,2} : 1231$

$$\eta_{\text{HY}} = \eta_I - \zeta_c \left( \frac{\psi_i}{2} + \frac{\phi_{i,2}^2}{2\psi_i} \right) \quad (a)$$

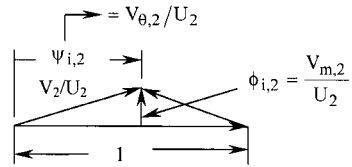
Impeller hydraulic efficiency:

$$(\eta_I \approx 0.90 - 0.95)$$

Collector loss:

( $\psi_i/2$  predominates)

$$(\zeta_c \approx 0.2 - 0.3)$$



Practical experience (roughness  $\epsilon$  constant for all sizes) yields the formula by W.K. Jekat:

$$\eta_{\text{HY}} \approx 1 - 0.8/[Q(\text{gpm})]^{0.25} \quad (b)$$

or 
$$\eta_{\text{HY}} \approx 1 - 0.071/[Q(\text{m}^3/\text{s})]^{0.25}$$

at all specific speeds.

However a deeper analysis treats losses  $L_{\text{imp}}$  as follows:

$$L_{\text{imp}} = k \frac{W_1^2}{2} + f \frac{\overline{W^2}}{2} \frac{\ell}{D_h} \quad (c)$$

where  $D_h$  = passage hydraulic diameter,

$\ell$  = passage length

$f$  = pipe-type friction factor

$k$  = incidence loss coefficient

$\overline{W^2}$  = the average square of the relative velocity within the passage along the rms or mean meridional streamline

$W_1$  = relative velocity just upstream of the impeller blades on the rms streamline

TABLE 3 Continued.

B) Mechanical Efficiency

From Eq. 9,

$$\eta_m = \frac{P_s - (P_{DF} + P_{B\&S})}{P_s} = 1 - \frac{\overbrace{P_{DF} + P_{B\&S}}^{\text{Bearing \& Seals}}}{P_s} \quad (d)$$

$$P_{DF} = \frac{C_m}{2} \rho \Omega^3 r_2^5 \quad (e)$$

Disk Friction

Where (for two sides of disk)  $C_m \approx 0.085 \left/ \left( \frac{\Omega r_{t,2}^2}{\nu} \right)^{0.2} \right.$  Typically  $C_m = 0.004$   
 (at  $R_e = 4.3 \times 10^6$ ) (f)

$\uparrow$   
 $R_e$

Shaft Power

$$P_s = \frac{\rho g \Delta H}{\eta_p} = \frac{\psi Q_s \rho \Omega^3 r_{t,2}^5}{\eta_p}$$

$$Q_s = \frac{Q}{\Omega r_{t,2}^5} = \Omega_s^2 \psi^{3/2} \Rightarrow P_s = \frac{\Omega_s^2 \psi^{5/2}}{\eta_p} \rho \Omega^3 r_{t,2}^5 \quad (g)$$

Combining the usually smaller  $P_{B\&S}$  with  $P_{DF}$ , Eq. (d) (with e, f and g) becomes

$$\eta_m = 1 - \frac{(C_m/2) \times \eta_p}{\Omega_s^2 \psi^{5/2}} \quad (h)$$

C) Volumetric Efficiency

From Eq. 11,

$$\eta_v = \frac{Q}{Q + Q_L} \approx \frac{1}{1 + 5 \left[ \frac{\frac{\delta}{r_R} \left( \frac{r_e}{r_2} \right)^2}{\Omega_s^2 \psi} \right]} \quad (j)$$

The clearance ratio  $\delta/r_R$  is typically 0.001 to 0.002

[Leakage back to impeller inlet across two rings (front and back) essentially doubles the leakage loss, changing the value 5 in Equation (j) to 10.]

inviscid solutions<sup>42</sup>, each on a surface of revolution generated by one of the meridional streamlines of the hub-to-shroud 2D solution and producing results like that of Figure 17. From this, one computes the diffusion factors (Eqs. 57–59) and decides whether the diffusion losses are significant—in which case a redesign is in order, followed by a further Q3D evaluation. This type of iterative design approach for impeller blading has led some designers to combine Q3D analysis with an “inverse” design approach and a performance prediction scheme as discussed in this subsection. Here, in distinction to the more common “direct” choice of the conformal blade shape (Figure 19) between inlet and outlet as

described in paragraph (e) (vi) under “Designing the Impeller,” one specifies the distribution of fluid dynamical quantities from inlet to outlet—such as  $UV_o$  or  $W$ —and finally produces the corresponding blading<sup>17,43</sup>. In this sense, specifying  $W_g$  as described in the same paragraph (e) (vi) is an inverse design procedure.

*Mechanical efficiency*  $\eta_m$ , as stated earlier, is largely the result of impeller disk friction. If the drag of bearings and seals is added, as in Eq. (d) of Table 3, the moment coefficient  $C_m$  in the disk friction formula (e) can be increased over known disk friction values<sup>44,45</sup> to include these effects. (On the other hand, the drag power loss of shaft seals, though usually quite small, is generally directly proportional to speed. Such losses can therefore be significant in small pumps running at lower-than-normal speeds.) The  $C_m$ -expression given in Formula (f) reflects this adjustment and includes the drag on both sides of a smooth impeller for a typical clearance ratio  $s/a = 0.05$ , where  $a$  is the disc radius. This works well for most impellers: The drag at the ring fits roughly compensates for the fact that the impeller eye has been cut out of the disk, and so on. (There is very little influence on  $C_m$  of the gap width  $s$  between impeller shroud and casing wall,  $C_m$  being proportional to  $(s/a)^{0.1}$  in general<sup>44</sup>. For very small  $s/a$ ,  $C_m$  instead grows as  $s/a$  decreases; see Refs. 44 and 45 for formulas.)

The value of  $C_m$  can be even larger for semi- or fully-open impellers, if the neighboring fluid is rotating faster relative to the wall—as is the case with radial-bladed open impellers. The fluid between a shrouded impeller and adjacent wall, on the other hand, rotates at half speed<sup>44</sup>. (In cases where the impeller surface and adjacent wall are both rough,  $C_m$  is larger than just discussed<sup>45</sup>.) Finally, notice in Eq. (h) that very low specific speed  $\Omega_s$  produces a dramatically low value of  $\eta_m$ . This drives  $\psi$  to the larger values of Figure 12 at low  $\Omega_s$ —also dictated by the  $W$ -deceleration considerations per Figure 22. Overall there is a benefit, despite possibly lower  $\eta_{HY}$  [Eq. (a)] due to the consequently greater  $\psi_i$  and collector loss.

*Volumetric efficiency*  $\eta_v$ , applies to leakage across impeller shroud rings or “neck rings” and balancing drums. Eq. (j) in Table 3 is an approximation for the leakage across a typical ring of a closed-impeller pump, assuming orifice-type flow at a discharge coefficient of  $\frac{1}{2}$ , as reported by Stepanoff<sup>4</sup>. Referring to Figure 2, leakage  $Q_L$  occurs at  $r = r_R$ , ( $r_R$  being approximately 1.2 times  $r_c$ ) under a pressure difference across the ring of about  $\frac{2}{3}$  that of the pump stage. If the shroud is removed and the open blades are fitted closely to the adjacent wall, as with open impellers, the consequent leakage from one impeller passage to the next across the blade tips does not affect  $\eta_v$ , and Eq. (j) should be modified accordingly. Rather, the tip leakage causes a hydraulic efficiency loss as previously discussed. Finally, as with  $\eta_m$ , Eq. (j) indicates that low- $\Omega_s$  pumps have low  $\eta_v$ .

At flow rates  $Q$  other than  $Q_{BEP}$ , the analytical methods described previously for computing the hydraulic efficiency are utilized, together with computation of the inlet and outlet velocity diagrams, which yield the ideal head and power curves as illustrated in Figure 6. In this procedure, the slip velocity  $V_s$  (Figure 15) applies to the BEP and, at other flow rates, the exit relative flow angle  $\beta_{f,2}$  can be assumed constant. This accords with the fact that  $V_s$  for the narrower active jet at low flow rates must be smaller. A blockage model for the thickening wakes and narrower active jets that develop as  $Q$  is decreased can be introduced to compute the one-dimensional velocity diagrams, but ignoring this at non-recirculating flow rates appears not to be serious in determining the shapes of the head and power curves.

*b) Shut-off and low flow.* The foregoing analyses apply over that portion of the flow rate range that does not involve recirculation, as illustrated in Figure 6. The complexity of recirculation has not been readily handled analytically, and this has forced pump designers to estimate the low-flow end of the  $H$ - $Q$  curve with the help of empirical correlations. Nevertheless, insightful fluid dynamical reasoning about the physics of the flow have led to useful expressions for the head developed and the power consumed at shut-off. Shut-off, then, in addition to the BEP, becomes the other anchor point of the head and power curves; and this—together with the shapes established for these curves at the higher flow rates—gives the analyst an idea of the intervening shapes.

*Shut-off head*  $H_{s,0}$  can be viewed as the sum of two effects occurring at  $Q = 0$ , each being represented by a term in this equation:

$$H_{s/o} = \frac{k_{imp} \times (U_{t,2}^2 - U_{h,1}^2)}{2g} + \frac{k_{ex} \times U_2^2}{2g} \quad (65)$$

or

$$\psi_{s/o} = \frac{k_{imp} \times \left( \frac{r_{t,2}^2}{r_2^2} - \frac{r_{h,1}^2}{r_2^2} \right)}{2} - \frac{k_{ex}}{2} \quad (66)$$

where the first term is the centrifugal effect of essentially solid body rotation of the fluid confined within the impeller; and the second term is the pitot effect of the recirculating fluid from the impeller that impinges against the volute or diffuser throats which in turn are connected through stagnant fluid to the exit port of the pump. While the factors  $k_{imp}$  and  $k_{ex}$  associated with these effects vary with the hydraulic configuration, the values involved can be estimated as follows:  $k_{imp} \approx 1$ , as the radial equation of motion<sup>3</sup> would indicate for fluid rotating at  $\Omega r$  everywhere within the blades, i.e., for  $r_{h,1} < r < r_{t,2}$  (Fig. 8). Thus, as indicated by Eqs. 65 and 66, increasing the minimum radius of the blades at inlet  $r_{h,1}$  tends to reduce the shut-off head. However, the presence or absence of fluid swirl in the region upstream of the impeller blades at shut-off has been found experimentally to affect the value of  $k_{imp}$  in surprising ways—sometimes increasing it above unity in such a way as to minimize the effect on shut-off head of any non-zero value of  $r_{h,1}$ . The value of  $k_{ex}$  depends on  $(r_3 - r_2)/r_2$ , or “Gap B” and other features of the impeller exit and collector geometry. It is usually in the range  $0.2 \pm 0.1$ , any change in the geometry that increases the shut-off power coefficient (see below) raising  $k_{ex}$  by driving more recirculating flow from the impeller against the volute or diffuser throats. Thus the shut-off head coefficient  $\psi_{s/o}$  (Eq. 66) for typical radial-flow pumps generally exceeds  $\frac{1}{2}$ , the value of 0.585 being advanced by Stepanoff<sup>4</sup>. Estimates for  $\psi_{s/o}$  are also indicated in Fig. 22b.

*Shut-off power consumption*  $P_{s/o}$  includes disk, bearing, and seal drag power  $P_D$  and that which drives the recirculation  $P_{recirc}$ . The latter is generally dominant by far. From similarity arguments (Eq. 33), the shut-off power coefficient

$$\hat{P}_{s/o} = \frac{P_{s/o}}{\rho \Omega^3 r_2^5} \quad (67)$$

is a constant for a given pump geometry. Mockridge, in a discussion attached to an ASME paper by Stepanoff, reasoned that a wider impeller (larger  $b_2$  at the same diameter  $D_2$ ) would recirculate more fluid at shut-off and therefore have a higher value of this coefficient. His correlation is shown in Figure 23 and is probably the most significant quantitative result available for predicting the performance of centrifugal pumps at shut-off conditions<sup>36</sup>.

*c) Complete prediction via CFD.* The uncertainties that have characterized the prediction of pump performance are now being overcome through advances in computational fluid dynamics. CFD entails three-dimensional solution of the flow fields within pumps via the Reynolds-averaged Navier-Stokes equations. Graf demonstrated the ability of a CFD computer code to calculate recirculation, the consequent prediction of the head curve for the impeller comparing favorably with experimental data<sup>46</sup>. The resulting distorted flows entering and leaving adjacent systems of impeller blades and stator vanes produce time-varying boundary conditions on each, the associated computational grids also moving relative to each other. This involves extensive, time-dependent computation. To provide solutions quickly on conventional, storage- and speed-limited workstations, some steady-flow codes treat these interfaces by circumferentially averaging the conditions at each point of the blade and vane leading and trailing edges as they appear in the meridional plane. Even with this simplification, pump analysts can now predict the entire performance curve of head within about two percent and the power curve with slightly less accuracy<sup>47</sup>.

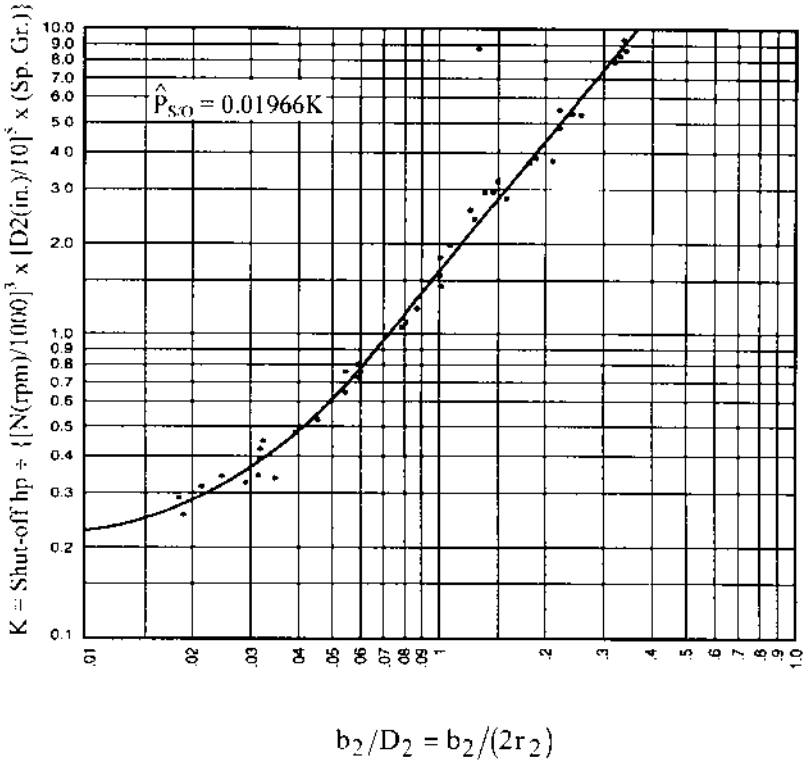


FIGURE 23 Shut-off power coefficient

The design task therefore resolves itself into an iteration between an efficient geometry-generating scheme and a rapid CFD flow and performance analysis of the geometry resulting from each iteration<sup>48</sup>. This is especially useful if a non-traditional geometry is involved, or if an efficient design is sought that will produce a desired performance curve shape. Nevertheless, many turbomachinery designers can make more rapid and valid judgments about their respective classes of machines through the time-honored iteration between a proprietary direct or inverse design and performance-prediction scheme and inviscid quasi-3D analysis<sup>41,43</sup>. They have developed reliable diffusion criteria (computed, for example, from Eqs. 59a and 59b) for interpreting the acceptability of the free-stream relative velocity distributions  $W_s$  and  $W_p$  on the blade surfaces (Figure 17) produced by the Q3D blade-to-blade solutions<sup>43</sup>. Because CFD codes solve the actual viscous flow field, the boundary condition on the blade surface is zero relative velocity. This can be at least partly overcome by displaying the CFD-distributions of pressures on the blade surfaces, the interpretation of which would require knowledge of the corresponding criteria for these pressures<sup>46</sup>. Also, the velocities at the edge of the boundary layer could be extracted from the CFD solution and displayed in familiar terms. A useful design approach for the present may therefore be to a) produce the final design by the more traditional methods and b) predict the performance curves via CFD<sup>49</sup>.

**Predicting Axial Thrust** The prediction of pump performance is not truly complete without the corresponding prediction of the hydrodynamic axial and radial thrust that the impeller(s) can be expected to encounter. A comprehensive treatment of radial thrust appears in Section 2.3.1, and a review of axial thrust and thrust balancing devices is cov-

ered in Section 2.2.1. However, obscure flow phenomena can profoundly affect the radial distributions of pressure on the outside surfaces of a shrouded impeller that give rise to the net axial thrust. These phenomena become even more complex when discharge recirculation occurs and can cause adverse mechanical response in high-energy pumps, as will be explained further on. As a basis for tackling such problems, the fundamentals of axial thrust are presented in Table 4 for shrouded centrifugal impellers that have leaking fluid flowing in the gaps between the impeller shrouds and the adjacent casing walls. The positive direction of the thrust  $T$  is taken toward the suction or eye of the single-suction impeller shown. The incoming axial momentum  $\rho Q V_{z,1}$  is generally quite small for radial impellers and has been omitted from the Table. It serves, however, to reduce  $T$ .

The centrifugal effect of the fluid spinning in the sidewall gaps causes a reduction in static pressure from the outer periphery (OD) of the impeller to the sealing ring, and this

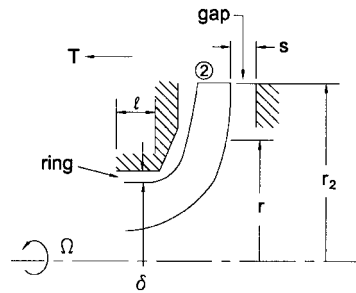
**TABLE 4** Leakage effects on axial thrusts

$$\text{Thrust} = (T_B - T_F) n_{\text{stgs.}} - T_{\text{slv}}$$

$$\text{where } T = \int_{r_{\min}}^{r_{\max}} 2\pi r p dr$$

$$\text{where } p = p_2 - \int^2 \frac{\rho}{g} \frac{V_{\theta, \text{gap}}^2}{r} dr$$

and  $p$  and  $V_{\theta, \text{gap}}$  are determined as follows in the absence of vanes in the gap:



A) For zero leakage flow, fluid outside impeller rotates at

half speed; i.e., at  $\frac{\Omega r}{2}$ ; namely,  $V_{\theta, \text{gap}} = \frac{\Omega r}{2}$ ; so that

$$p_o - p_i = \int_i^o \rho \frac{V_{\theta, \text{gap}}^2}{r} dr = \frac{\rho \Omega^2}{4} \int_i^o r dr = \rho \frac{\Omega^2 (r_o^2 - r_i^2)}{8}$$

or

$$p_o - p_i = \frac{\rho}{8} \Omega^2 r_o^2 \left[ 1 - \left( \frac{r_i}{r_o} \right)^2 \right]$$

$$\left[ \begin{array}{l} \text{Note: This is } 1/4 \text{ of what } (p_o - p_i) \text{ would be if} \\ V_{\theta, \text{gap}} = \Omega r \text{ (full wheel speed - as on the front)} \\ \text{side of a semi-open impeller} \\ \text{then, one gets } (p_o - p_i) = \frac{\rho}{2} \Omega^2 r_o^2 \left[ 1 - \left( \frac{r_i}{r_o} \right)^2 \right] \end{array} \right]$$

B) For non-zero leakage

1) Inflow:  $V_{\theta, \text{gap}}$  averages to be  $>$  half speed

$\Rightarrow$  greater  $(p_o - p_i)$  than at half speed (or zero leakage)

2) Outflow:  $V_{\theta, \text{gap}}$  averages to be  $<$  half speed

$\Rightarrow$  nearly constant pressure from  $(p_o - p_i)$

TABLE 4 Continued.

Specifically,

$$\text{where } V_{\theta, \text{gap}} = \begin{cases} \Omega r_2 \times f_{\text{inflow}} \left( \frac{r}{r_2}, \Phi_{\text{lkg}} \right) \times f_{\text{width}} \\ \text{or} \\ \Omega r \times f_{\text{outflow}} \left( \Phi_{\text{lkg}} \right) \times f_{\text{width}} \end{cases}$$

$$\text{where } \Phi_{\text{lkg}} = \frac{Q_{\text{leakage}}}{\Omega r_2^3} \Rightarrow \begin{cases} \text{Interaction of} \\ \text{leakage and} \\ \text{pressure at ring} \end{cases}$$

$$\text{where } Q_{\text{leakage}} = f_L \left( \ell, \delta, \Omega, v, \Delta p_{\text{ring}} \right)$$

$$f_{\text{inflow}} = \left( 0.5 - \frac{450}{\pi} \left| \Phi_{\text{lkg}} \right| \right) \frac{r}{r_2} + \frac{450}{\pi} \left| \Phi_{\text{lkg}} \right|$$

$$f_{\text{outflow}} = 0.5 - 100 \left| \Phi_{\text{lkg}} \right|$$

$$f_{\text{width}} = \frac{\sqrt{A^2 + A} - A}{0.5}$$

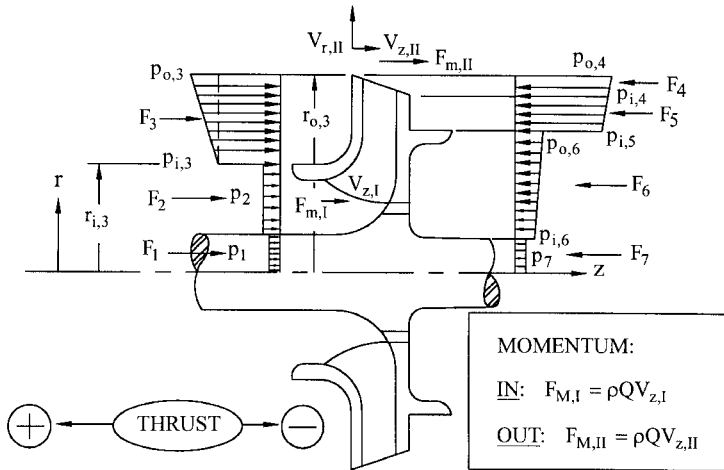
$$\text{where } A = 1/[5 \text{ s/r}_2]$$

is quantified in the expressions given for the swirl velocity component  $V_{\theta}$ . These expressions are curve fits to experimental data for the leakage flowing radially inward on either or both sides of the impeller<sup>50</sup> and for outflowing leakage as occurs on the back side (away from the “front” or suction side) of multistage pump impellers due to the higher pressure arising from the diffusing system downstream of each impeller<sup>51</sup>. In the absence of leakage, the fluid in the sidewall gap rotates at about half the local impeller wheel speed; that is,  $V_{\theta} = \Omega r/2$ , and this half speed is typical of the gap flow near the impeller OD, even in the presence of leakage. The greater the inflow leakage, the lower the pressure becomes at the entrance to the ring clearance. The major effect is that of swirl or the tangential component of velocity  $V_{\theta}$ , which varies inversely with radius unless casing wall drag interferes. More leakage flow is less influenced by this drag and so experiences a greater centrifugal effect. This in turn means more pressure drop from OD to ring. (The leakage rate, of course, is affected, the solutions for both leakage and pressure distribution being linked and usually requiring iteration.) The opposite effect happens for outflow on the back side of multistage pump impellers. Here the fluid enters the sidewall gap at a small radius (see Section 2.2.1) and so with negligible swirl. It flows outward without picking up much swirl, especially if there is substantial radial outflow leakage, which means the centrifugal effect is small, yielding a nearly constant pressure versus radius. The overall result is more net thrust than might be expected from a cursory look at the pressure-loaded surfaces.

If wear ring clearances increase during the life of the pump, the net thrust of multistage pump impellers increases. Likewise, unequal ring wear leads to uncertain changes in the thrust of a “balanced” single- or double-suction impeller with inflow to wear rings on both sides. Similarly, these theories can be applied to balancing drums and other such devices described in Section 2.2.1.

Integration of the pressure equation in Table 4 becomes a chore unless the whole theory is computerized. A quick estimate of the thrust is possible, however, if the distributions of pressure in the separable domains of the surfaces are assumed to be linear; in that case,

TABLE 5 Approximate axial thrust calculation



$$\underline{\text{THRUST}} = F_7 + F_6 + F_5 + F_4 - F_3 - F_2 - F_1 - F_{m,I} + F_{m,II}$$

$$\text{For Const. } p \text{ Forces: } F_j = p_j \times 2\pi (r_{j,o}^2 - r_{j,i}^2) \quad j = 1, \dots, 7$$

i = inner; o = outer

$$\text{For Linear } p(r) \text{ Forces: } F_j = F_{j,\text{const.}} + F_{j,\text{var}}$$

$$\text{where } F_{j,\text{var}} = \frac{1}{3} \pi r_{j,o}^2 \left[ 2 - \frac{r_{j,i}}{r_{j,o}} - \left( \frac{r_{j,i}}{r_{j,o}} \right)^2 \right] \times (p_{j,o} - p_{j,i})$$

Example:

$$F_3 = p_{i,3} \times 2\pi (r_{o,3}^2 - r_{i,3}^2) + \frac{1}{3} \pi r_{3,o}^2 \left[ 2 - \frac{r_{3,i}}{r_{3,o}} - \left( \frac{r_{3,i}}{r_{3,o}} \right)^2 \right] \times (p_{o,3} - p_{i,3})$$

the integration is simple and yields the closed-form results of Table 5. This table also indicates how to account for each element of the thrust, including the axial momentum terms, which become significant for higher-specific-speed mixed-flow impellers. In all cases, in order to proceed with the calculation, the static pressure at the impeller OD must be known, as it is from the boundary condition imposed at the OD that the rest of the pressure distribution emerges. Even for substantial leakage, the pressure drop of the fluid entering the sidewall gaps from the impeller exit is small or negligible; therefore, the impeller pressure essentially applies in the gap (at the OD) as well. The foregoing methods of predicting pump head also yield the impeller OD pressure, which is usually between 75 and 80% of the stage pressure rise above inlet.

Thrust computations can therefore be coupled with the head-curve prediction scheme being employed for the pump, thereby yielding predicted thrust curves together with the predictions of hydraulic performance.



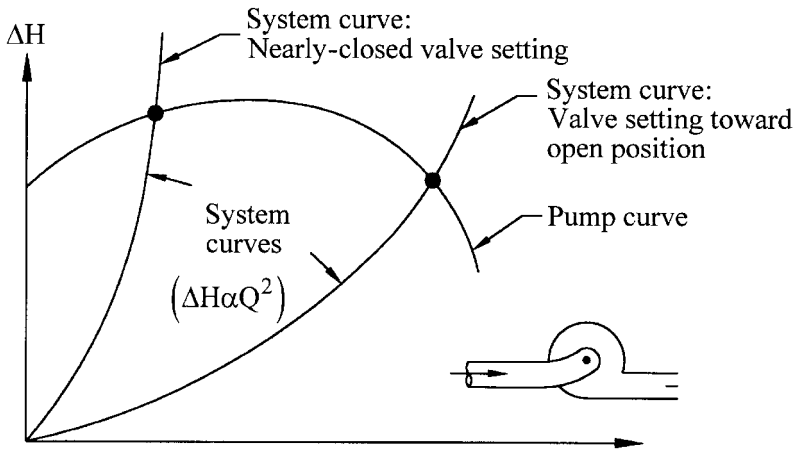
**Ensuring Stable Performance** The ability for a pump to run smoothly with minimal pressure-rise and flow-rate excursions is dependent on the shape of the pump head-flow performance curve and the characteristics of the system in which it operates. There are two types of pump-system instability; namely, a) static instability, which can be ascertained by studying the pump and system head curves, and b) dynamic instability, which requires more detailed knowledge of the system<sup>52</sup>. (In addition to these system-related instabilities, there is the unsteady behavior of the separated and recirculating flows that occur when a pump operates a flow rate substantially below the BEP. Called hydraulic instability, this becomes important in higher-energy applications and is therefore discussed later.)

*a) Static stability and instability.* Figure 24 illustrates two pumping systems; namely, a) a piping system in which the flow is turbulent and largely independent of Reynolds number; so, the head drop  $\Delta H$  through it is proportional to  $Q^2$ , and b) two reservoirs with a constant difference  $\Delta H$  between the two liquid surfaces and comparatively negligible head loss in the pipes connecting them. In each case, the pump is designed to produce head  $\Delta H$ , as required to deliver the desired flow rate  $Q$ . The influence of the pump head curve shape is immediately appreciated in Case (b): the curve “droops” as  $Q$  is reduced to shut-off, thereby producing two vastly different flow rates at the same head. In fact, however, the pump will not operate at the lower- $Q$  intersection point of the two curves. The pump shut-off head is less than  $\Delta H$ , so it will produce no positive flow rate. Instead, as discussed in Section 2.3.1, fluid will flow backwards through the pump. Further, if circumstances could allow operation at this lower- $Q$  point, even a vanishingly small increase of  $Q$  would cause a further, divergent increase because the head of the pump exceeds the  $\Delta H$  of the system. Likewise, a small decrease leads to even lesser  $Q$  because the system  $\Delta H$  exceeds that of the pump. This is called “static instability.” Conversely, the higher- $Q$  point of Figure 24b is “statically stable,” small departures in  $Q$  being suppressed by algebraically opposite signs of the difference between the system and pump heads. Both intersection points of Figure 24a are seen by this type of analysis to be statically stable. If the operator increases the frictional resistance by closing up a valve in the piping system, the operating point simply moves to the left on the curve and remains stable. Thus, it is concluded that if the slope of the pump H-versus- $Q$  curve is *less* than that of the system, operation will be *statically stable*—and vice versa.

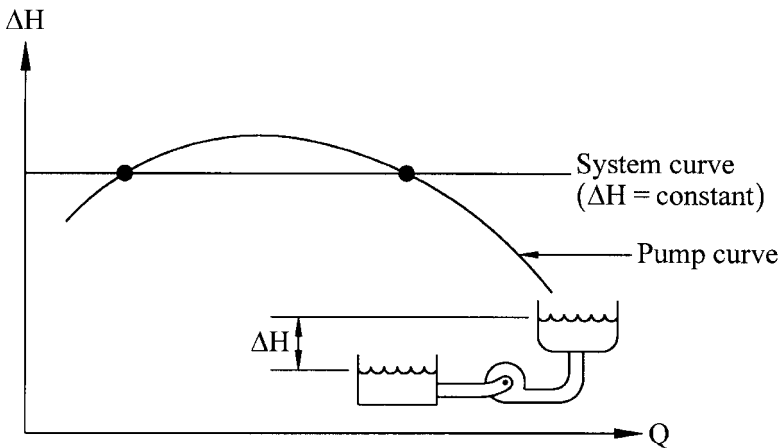
Most pumping systems are combinations of the “pure friction” type of Figure 24a and the “purely elevation” type of Figure 24b. In this case of static stability, the drooping pump head curve presents no problem. Theoretically, it is possible to have a pump head curve with a kink that could have a more positive slope than that of a system curve, which might intersect it at such a kink. The high- $\Omega_s$  curve of Figure 22b depicts a kink or dip, which is due to stalled flow within a mixed- or axial-flow impeller that is not sufficiently confined by the impeller to be maintained in solid body rotation. (It is the centrifugal effect of such rotation that maintains the pressure rise in radial-flow impellers despite the stalling.) That particular pump, if applied to a system that never intersects the pump head curve at the kink, would never experience static instability. On the other hand, the designer may want to take on the challenge of designing a machine without such a kink. The previously mentioned design procedure utilizing CFD in both the impeller and the diffuser to check whether the kink is gone would be a way of tackling this problem<sup>53</sup>.

In-depth discussion of the variety of systems that can be encountered, including multiple systems and parallel operation of multiple pumps, can be found in Sections 2.3.1, 8.1, and 8.2. Purely from a static stability standpoint, most of these situations demand a substantially negative slope of the head curve throughout the range of flow rate  $Q$ —or what is commonly specified as a pump with head “continuously rising to shut-off.” (This “rise in head” versus a drop in  $Q$  should not be confused with the pump developed head  $H$ , which is also properly termed the “head rise”  $\Delta H$ , produced by the pump at a given value of  $Q$ .)

*b) Dynamic instability.* If the system has appreciable capacitance, operation may not be stable if the slope of the pump head curve is positive or even zero<sup>54</sup>. This is true even though the slope of the pump head curve is less than that of the system head curve as required above for static stability—as with the lower- $Q$  intersection point of Figure 24a. Dynamic instability can be manifested as pump surge, a phenomenon wherein the flow



a) System with frictional resistance only



b) System with elevation change only

FIGURE 24A and B Pump-system stability

rate oscillates and can even be alternately positive and negative through the pump<sup>54</sup>. This is characteristic of “soft” systems that contain vessels with free surfaces and, therefore, appreciable capacitance. Two-phase flow increases the capacitance of a system and can cause dynamic instability. For example, fluctuating vapor volume within the propellant pump inducers can contribute to the dynamic instability of a rocket propulsion system<sup>55</sup>.

On the other hand, a “hard” piping system with no capacitance is theoretically capable of accommodating a pump that has a flat or drooping head curve and that operates on that flat or drooping section of the curve. Low-specific-speed pumps can have drooping curves (Figure 22b), especially if designed with a high head coefficient  $\psi$  at the BEP. Figures 5 and 7 of Section 2.3.1 depict flat and drooping curves of low- $\Omega_s$  radial-bladed pumps, a type that is widely used in low-cost, small sizes. If properly applied, such machines will operate with stability. On the other hand, a conservative approach that guarantees both static

and dynamic stability for the widest range of applications is to design all pumps without flat spots or droops in the head curves.

**DESIGN EXAMPLE**

To illustrate the application of the preceding design information, the basic hydraulic design requirements are presented in Table 6 for a single-stage centrifugal water pump with a volute collector. The chosen conditions compute to a universal specific speed  $\Omega_s$  of 1 ( $N_s = 2733$ , and  $n_q = 52.9$  from Eqs. 38a and 38b). The pump is to be designed for a suction specific speed  $\Omega_{ss}$  of 4.5 ( $N_{ss} \equiv S = 12,300$  by Eqs. 41 and 42), therefore, a “performance-NPSH” (see NPSH discussion in Section 2.3.1) or  $NPSH_{3\%}$  of 14 ft (4.27 m). As such, this pump is readily applicable to taking water from an atmospheric reservoir with some suction lift. Although acceptable for 1780 rpm specified for this pump, this suction-specific speed  $\Omega_{ss}$  of 4.5 is regarded as high for pumps with more head (energy level) than this one (see the energy-level discussion later).

**Impeller Design**

**SUCTION NOZZLE** Beginning upstream, an ideal, axial-flow approach passage is assumed —this is known as an “end-suction” configuration. The suction-approach passage or suction branch (not shown) is simply a conical nozzle that increases the velocity of the fluid from the suction port to the impeller eye by about 50 percent in an axial distance of about half the diameter of the eye. This helps to ensure the existence of uniform flow at the eye. Too short a nozzle would mean excessive local meridional (axial in this geometry) velocity at the impeller shroud and possible separation.

**IMPELLER INLET** Beginning with  $\Omega_{ss}$  of 4.5, computations for this example are carried out in Table 7 for the impeller eye geometry. The choice of the  $NPSH_{3\%}$  correlation of Table 1 is used, with  $k_1 = 1.69$  and  $k_2 = 0.102$ . The local maximum velocity at the eye  $V_{1,sh}$  ( $=V_{m,1,sh}$ ) is assumed to be 25% greater than the one-dimensional average  $V_e = Q/A_e$ . This is smaller than the bladeless result of Figure 14, but is typical of this end-suction configuration,

**TABLE 6** Given conditions for design example (single stage, end-suction volume pump)

Speed	= 1780 RPM	
Flow Rate	= 2500 gpm (0.1577 m <sup>3</sup> /s)	
Head	= 104 ft. (31.7 m)	Fluid: Water $\left\{ \begin{array}{l} \text{sp. gr.} = 1 \\ \nu = 1 \text{ cs.} \end{array} \right.$
Specific Speed	$\Omega_s = 1; N_s = \frac{1780 \sqrt{2500}}{(104)^{3/4}} = 2733; n_q = \frac{1780 \sqrt{0.1577}}{(31.7)^{3/4}} = 52.9$	
Suction Specific Speed	$\Omega_{ss} = 4.5 \quad (S = 12,300)$	
NPSH	$= \left\{ \frac{1780}{12,300} \right\}^{4/3} (2500)^{2/3} = 14 \text{ ft. (4.27 m)}$	

TABLE 7 Impeller inlet (design example)

$$\Omega_{ss} = 4.5 = \frac{\sqrt{\pi \phi_e \left(1 - \frac{r_s^2}{r_e^2}\right)}}{(\tau/2)^{3/4}} \quad (\text{from Eq. 50})$$

$$\text{For } \tau = (1.69 + 0.102) \phi_e^2 + 0.102$$

$$\phi_e = 0.29 = \text{eye flow coefficient}$$

Eye dia/2 = eye radius:

$$r_e = \sqrt[3]{\frac{Q}{\Omega \pi \phi_e \left(1 - \frac{r_s^2}{r_e^2}\right)}} = \sqrt[3]{\frac{2500 \text{ gpm} / 449 \frac{\text{gpm}}{\text{ft}^3 / \text{sec}}}{\frac{\pi}{30} \times 1780 \times \frac{\pi}{\text{sec}} \times 0.29}} \quad (\text{from Eq. 49})$$

$$[r_s = 0 \text{ (no shaft in eye)}]$$

$$r_e = 0.3201 \text{ ft. (0.0976 m)}$$

$$r_e = 3.84 \text{ in. (97.6 mm)}$$

$$\begin{aligned} V_e &= 17.3 \\ &= \phi_e U_e \\ &= \Omega r_e \end{aligned} \quad \begin{array}{l} W = 62.1 \text{ (18.9)} \\ 16.2^\circ = \beta_{f,1} \\ U_e = 59.6 \text{ ft/sec. (18.2 m/s)} \end{array}$$

$$(\text{See Fig. 25}): R_{sh} = \frac{r_e - r_s}{2} = 1.92 \text{ in. (48.8 mm)}$$

Other dimensional data shown on Fig. 25.

including the effect of the blading. Moreover, the value of  $k_1$  should be more than adequate for this value of  $V_{1,sh}$ .

The  $\Omega_{ss}$  and  $\tau$ - $\phi_e$  relationships yield the eye flow coefficient  $\phi_e$ , which in turn sizes the eye.  $\phi_e = 0.29$  implies a  $\tau$ -value of 0.253, which is typical. However, lower  $\phi_e$ - and  $\tau$ -values are common, especially for the case of a shaft through the eye, because this tends to maintain the level of  $\Omega_{ss}$  in the face of the  $r_s$ -effect in Eq. 50. The nominal velocity diagram at the eye—substantially the shroud-end or tip of the blade leading edge—shows  $V_e$  rather than  $V_{1,sh}$  for the meridional component of velocity and so is not the actual velocity diagram at that location. Rather, this triangle serves to identify the geometry through the basic ratio  $\phi_e = V_e/U_e$ —without having to deal with the uncertain choice of  $V_{1,sh}/V_e$ . Moreover,  $\phi_e$  is the tangent of the tip relative flow angle  $\beta_{f,1}$  as it would be for a uniform axial velocity profile in the eye.

With the eye radius  $r_e$  established, the local shroud radius of curvature  $R_{sh}$  follows from the guidelines associated with Figure 13. The geometry established so far is illustrated in Figure 25. Before the full picture shown there can be established, the outlet must be sized.

**IMPELLER OUTLET** The computations in Table 8 for the impeller exit begin with the choice of the typical value of  $22\frac{1}{2}$  degrees for the outlet blade angle  $\beta_{b,2}$ . This enables the head coefficient  $\psi$  to be chosen under the guidance of the upper curve in Figure 12. The value 0.385 is selected, and this yields the impeller diameter of 12 in. (304.8 mm). The other curve in Figure 12 is for outlet flow coefficient  $\phi_{i,2}$ , which conveniently equals 0.1715 for

$N = 1780 \text{ rpm}$   
 $Q = 2500 \text{ gpm } (0.1577 \text{ m}^3/\text{s})$   
 $\Delta H = 104 \text{ ft. } (31.7 \text{ mm})$

$\Omega_{ss} = 4.5 \text{ (} S = 12300\text{)}$   
 $NPSH_R = 14 \text{ ft. } (4.27 \text{ m})$

$\Omega_s = 1 \text{ (} N_s = 2733\text{)}$

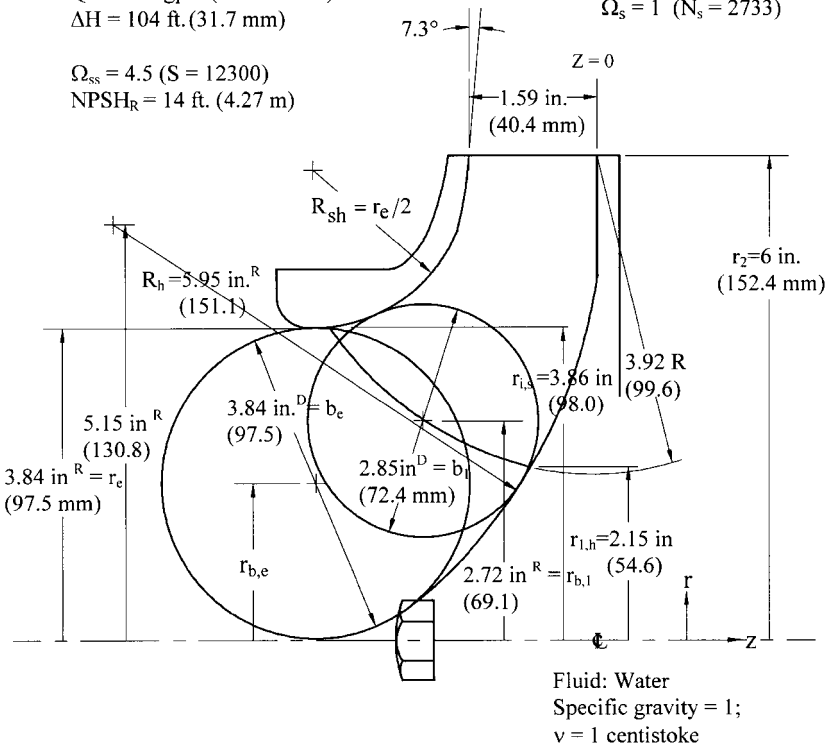


FIGURE 25 Impeller hub and shroud profiles (design example)

$\Omega_s = 1$ . This leads to the exit width  $b_2$  after adding in the leakage and the blockage of blades and boundary layers per the computations of Tables 9 and 10.

However, Anderson<sup>6</sup> points out that what matters for centrifugal pump performance is neither the blade angle nor the exit width individually, but the impeller outlet relative area  $2\pi r_2 b_2 \sin \beta_{b,2}$ . Choosing a higher blade angle is possible if  $b_2$  is correspondingly reduced (and  $\phi_{r,2}$  increased) so as to maintain this area and therefore the relative velocity  $W$ . Figure 15 shows that  $V_{\theta,2}$  is thereby essentially unchanged; this in turn preserves the impeller head.

**EFFICIENCIES** Anderson's overall pump efficiency correlation (Figure 10 and Eq. 44) and the component efficiency expressions of Table 3 lead to the results of Table 9. These give an indication of the relative magnitudes of the losses and are as follows:

- Overall efficiency  $\eta_p = 0.8550$
- Mechanical efficiency  $\eta_m = 0.9814$
- Volumetric efficiency  $\eta_v = 0.9833$  (leakage across front and back rings)
- Hydraulic efficiency  $\eta_{HY} = 0.8860$

$\eta_{HY}$  is at this point simply deduced from the others, beginning with Anderson's correlation. Although it is confirmed by Jekat's correlation in the table, it can be found in a

**TABLE 8** Impeller outlet (design example)

From Figure 12

$$\beta_{b,2} = 22 \frac{1}{2}^\circ \rightarrow \phi_2 = \frac{V_{m,2}}{U_2} = 0.1715 \quad (= \phi_i)$$

$$\rightarrow \psi = \frac{g_0 \Delta H}{U_2^2} = 0.385$$

$$(U_2 = \Omega r_2) = \frac{\pi}{30} \times 1780 \times \frac{6}{12} = 93.2 \frac{\text{ft.}}{\text{sec.}} (28.4 \text{ m/s})$$

$$r_2 = \sqrt{\frac{g \Delta H}{\Omega^2 \psi}} = 12 \sqrt{\frac{32.174 \times 104}{\frac{\pi^2}{30^2} \times (1780)^2 \times 0.385}}$$

$$= 6 \text{ in. (152.4 mm) [12 in. (304.8 mm) dia.]}$$

$$\text{Width: } b_2 : A_2' = \pi D_2 b_2'$$

$$b_2 = b_2' + 2\delta_0^* + \text{Leakage Effect}$$

Solve after obtaining volumetric efficiency and getting approximate passage length (to compute  $\delta_0^*$ )

detailed computation of the hydraulic losses via one-dimensional methods. This will be carried out further on to obtain the performance characteristic curves. Meanwhile, this initial computation enables the determination of  $V_{\theta,2}$  at the end of Table 9, which, along with  $V_{m,2}$  from Table 8, is a major element of the outlet velocity diagram of Figure 26.

**BLOCKAGE AND WIDTH AT IMPELLER EXIT** With the leakage and exit blade angle information, Table 10 contains the computations of the blockage and the exit width  $b_2$ . This entails the choice of the number of blades, the blade thickness  $t$  (2% of the impeller diameter and typically assumed to exist at the exit and elsewhere on the blades except near the leading edges where typically half that value is chosen), and the approximate blade length  $\ell$  (assuming the mean-streamline blade angle to be constant at  $22\frac{1}{2}$  deg). The boundary layer blockage is computed from the following approximations:

- Adverse pressure gradients on the blades lead to a boundary layer displacement thickness  $\delta^*$  of twice the zero-pressure gradient value  $\delta_0^*$  on each blade surface.
- Secondary flows scrub the boundary layers from the hub and shroud surfaces; so,  $\delta^*$  is assumed to be equal to  $\delta_0^*$  on those surfaces.
- $\delta_0^* = 0.0462 \ell^{0.8} \nu^{0.2} / W^{0.2}$  for flat-plate, turbulent flow<sup>56</sup>, and is approximated in this example for low viscosity by a linear growth with length along the blade.

The resulting thickness of the boundary blockage is 0.0732 in (1.86 mm) on the blades, which themselves have a thickness of 0.24 in (6.1 mm). Because these thicknesses are inclined at the  $22\frac{1}{2}$ -deg outlet angle, the actual circumferential blockage is  $(1 - \epsilon_{2,b}) = (1 - 0.870)$  or 13 percent of  $2\pi r_2$ . In particular,  $(0.24 + 0.0732)/\sin(22\frac{1}{2} \text{ deg}) = 0.82$  in or (6.1

**TABLE 9** Component efficiencies (design example)

---


$$\text{Efficiency: } \eta_p = 0.94 - 0.08955 \left( \frac{2500}{1780} \right)^{-0.21333} - 0.29 \left[ \log_{10} \left( \frac{2286}{2733} \right) \right]^2 = 0.8550$$

(Eq. 44)

$$\text{Mech. Eff y: } \eta_m = 1 - \frac{0.002 \times 0.8550}{1^2 \times (0.385)^{5/2}} = 0.9814 \quad [P_D = 1.43 \text{ hp. (1.07 kW)}]$$

(from Table 3)

$$\text{Volumetric Efficiency: } \eta_v = \frac{1}{1 + 5 \frac{0.0016 \times (3.84/6)^2}{1^2 \times 0.385}} \times 2 = 0.9833$$

(from Table 3)

$$\text{Hydraulic Efficiency: } \eta_{HY} = \frac{\eta_p}{\eta_v \eta_m} = \frac{0.8550}{0.9650} = 0.886 \quad \text{vs.}$$

(Eq. 8)

(Jekat's formula in Table 3):

$$\eta_{HY} \approx 1 - \frac{0.8}{(2500)^{0.25}} = 0.887$$

$$\Rightarrow V_{\theta,2} = \frac{32.174 \times 104}{93.2 \times 0.886} = 40.5 \text{ ft/sec.}$$

$$\Rightarrow \psi_i = \frac{40.5}{93.2} = 0.435$$


---

+ 1.86)/sin(22½ deg) = 20.8 mm per blade, which for all six blades is 0.130 times the circumference of 37.7 in (958 mm). The width  $b_2$  is computed to maintain  $V_{m,2}$  at the chosen value of  $0.1715 \times U_2$ , while accommodating this blockage and that of the sidewall boundary layers. Altogether, it can be computed from these data that 85 percent of the meridional exit area  $2\pi r_2 b_2$  is estimated to remain open for the one-dimensional flow of  $(Q + Q_L)$  at velocity  $V_{m,2}$ , the boundary layers causing ⅓ of the blockage. This is quite typical. An openness of 90 percent is possible for larger impellers.

**HUB-SHROUD PROFILES** It is now possible, through the guidelines outlined in the discussion of Figure 13, to finish plotting the hub and shroud profiles in Figure 25, which are also seen in Figure 26c. At this point, the envelope of the leading edges of the blades is approximated by a circular arc—later modified somewhat in the construction of the blades. The arithmetic average radius of the meridional passage at the leading edges is found with the circle of diameter 2.85 in (72.4 mm) to be 2.72 in (69.1 mm). The resulting line passing through the center of the circle is normal to both hub and shroud and is approximated by the dashed straight-line leading-edge quasi-normal shown in the Figure 26c.

**INLET VELOCITY DIAGRAMS** The rms radial point on this quasi-normal line of Figure 26c crosses the leading edges of the blades at  $r_{1,\text{mean}} \equiv r_{1,\text{rms}} = 2.91$  in (73.9 mm) and is slightly larger than the arithmetic average radius of 2.72 in (69.1 mm). It is this latter radius that

**TABLE 10** Impeller blade blockage and width at exit (design example)

$$\left. \begin{array}{l} \text{Blade no.} \} n_b: \text{ Assume} = 6 \\ \\ \text{Blade thickness} \} t = 0.04 r_2 = 0.24 \text{ in. (6.1 mm)} \end{array} \right\} \begin{array}{l} \ell = \Delta m / \sin \beta \approx \frac{3.5 \text{ in.}}{\sin 22 \frac{1}{2}^\circ} = 9.15 \text{ in. (232.4 mm)} \\ \text{(Eq. 56)} \\ \sigma = \frac{6 \times 9.15}{\pi \times 12} = 1.46 \rightarrow \text{OK} \\ \text{(Eq. 53)} \end{array}$$

Check Solidity :

$$\begin{array}{l} \epsilon_{2,b} \text{ (blades only)} = \frac{6(0.0732 + 0.240)}{\pi \times 12 \times \sin 22 \frac{1}{2}^\circ} = 0.870 \\ \\ \left\{ \begin{array}{l} \delta_o^* \approx 0.002 \times \ell \approx 0.002 \times 9.15 \text{ in. (232.4 mm)} \\ 2\delta \approx 4 \delta_o^* \approx 0.0732 \text{ in. (1.86 mm) on blades} \\ 2\delta \approx 2 \delta_o^* \approx 0.0366 \text{ in. (0.93 mm) on hub and shroud} \end{array} \right. \end{array}$$

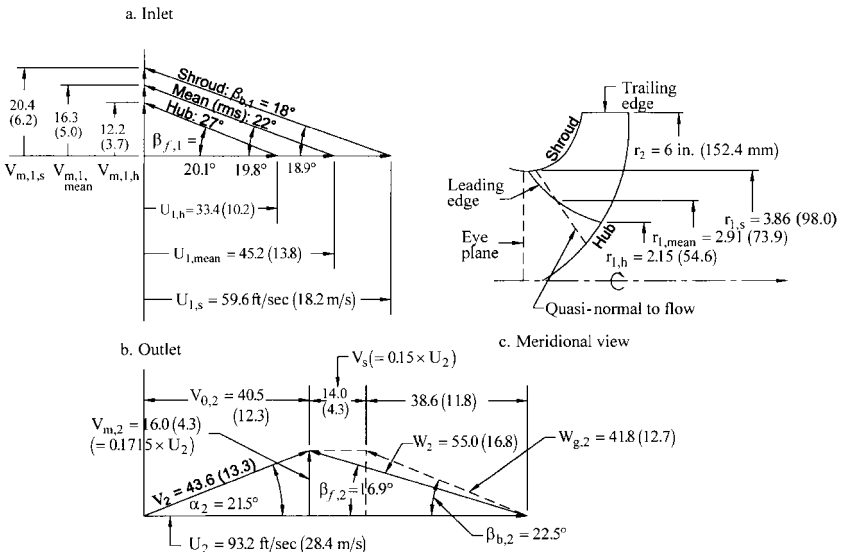
gpm & ft/sec to inches  
 $\eta_v$

$$b_2 = 0.0366 + \frac{2500 \times 0.3208 / 0.9840}{\underbrace{0.1715 \times 93.2}_{V_{m,2}} \times \underbrace{0.870}_{\epsilon_{2,b}} \times \pi \times 2 \times 6} = 1.59 \text{ in. (40.4 mm)}$$

(Since

$$b_2 = 2\delta_o^* + \frac{Q + Q_L}{V_{m,2} \times \epsilon_{2,b} \times \pi \times 2 \times r_2}$$

)



**FIGURE 26A through C** Impeller velocity diagrams for design example: a) inlet; b) outlet; c) meridional view



must be used in computing the one-dimensional meridional velocity. After obtained, it is applicable to the rms location (the location of the “mean” or “rms” inlet velocity diagram). This diagram is one of three triangles shown for the inlet in Figure 26a, the other two being located at the hub and shroud locations of the blade leading edges. Notice that  $V_{m,1}$  for the rms triangle is 16.3 ft/sec (5.0 m/s), which is slightly less than the eye velocity  $V_e$  of 17.3 (5.3). Allowing for blade blockage, this would bring the blocked meridional velocity  $V_m$  within the blading closer to  $V_e$ , the objective being to keep  $V_m$  constant in the inlet region and turn into the radial direction. The other triangles correspond to the radial locations of the blade at hub and shroud, as illustrated in Figures 26c and 27, and assume that  $V_{m,1,sh} = 1.25$  times  $V_{m,1}$ , and  $V_{m,1,h} = 0.75 V_{m,1}$ . A full Q3D solution would determine these velocities more accurately; however, the design usually proceeds in this way—largely because the hub blade angle is usually a good deal larger than hub flow angle. Efforts to match the hub flow angle more closely entail special blading that is beneficial for high-energy pumps but has little effect otherwise. The blade angle at the shroud is slightly lower than the flow angle (by about 1 deg). This slightly negative incidence is actually ideal for efficient flow and minimum cavitation. The largest values of  $U$  and  $W$  exist at the shroud, as can be seen for the shroud inlet triangle, making it important to have the best match at that point. Two deg positive incidence is quite common at the mean or rms radial location and allows for blockage by the blades that does not increase the relative velocity  $W$  as the fluid enters the impeller.

**OUTLET VELOCITY DIAGRAM** The outlet velocity components having been found in Tables 8 and 9, the slip velocity  $V_s$  must still be found in order to obtain the complete outlet velocity diagram shown in Figure 26b. This slip is computed by Pfeleiderer’s method (Table 2), which utilizes the  $r(m)$  shape of the mean meridional streamline illustrated in Figure 27,  $V_s$  emerging as 15% of  $U_2$ . The “ $a$ ” factor for influence of the collector geometry was taken in the middle of the range for volutes at 0.75; (see Table 2). Wiesner’s Eq. 52 yields 17.65%. This would mean 6% less  $V_{\theta,2}$  and head. However, this discrepancy is not unexpected, and in view of the earlier discussions on slip, the Pfeleiderer result is chosen as more realistic.

Nevertheless, uncertainty in the slip is the Achilles heel of the one-dimensional analysis method. For this reason, most analysts “calibrate” their codes by deducing the slip from test results and applying it to impellers of similar geometry. For Pfeleiderer’s method, this would be done by calibrating the “ $a$ ” factor. CFD solutions now appear to be the best approach to overcoming this difficulty.

As has been emphasized heretofore, this outlet velocity diagram contains the basic information about the performance and design of the pump. It supplies the boundary conditions for the volute design, but first the impeller blading that must produce it will be established and evaluated.

**IMPELLER BLADING** As indicated in Figure 26, the blade angles at both inlet and outlet have been chosen at hub, mean, and shroud (with the same  $22\frac{1}{2}$  deg all across the trailing edge being assumed, although some would specify a little variation). Fitting a reasonable blade shape between these end conditions can be done in the conformal plane (illustrated in Figure 19). These shapes, when transformed as described earlier, yield the hub, mean, and shroud blade shapes identified in the polar view of Figure 28. In actuality, the inverse “point-by-point” method was used, specifying  $W_s$  as indicated in Figure 29 and, at each of the 21 stations along the mean line of Figure 27, developing the velocity diagrams in the manner employed to arrive at Figure 26b; obtaining  $\beta_b$  at each station; and developing the *mean-streamline blade shape* of the polar view with Eq. 60. Involved in this procedure—which was computerized—was the calculation at each station of the blockage and of the local slip velocity, the latter being estimated as a fraction of the discharge slip velocity  $V_s$  that increases rapidly to unity as the exit is approached.

Note that the meridional area is needed at each station in order to compute  $V_m$ . As indicated in Figure 27, this is approximated here as the area of the frustum of a cone defined by the dashed lines or “quasi-normals,” which are as nearly perpendicular to both hub and shroud as possible. Except for some machines with meridionally curved passages and a large passage width-to-length ratio causing the true normals to be strongly curved, the quasi-normal approach works well.

## Description of the pressure side of the blade

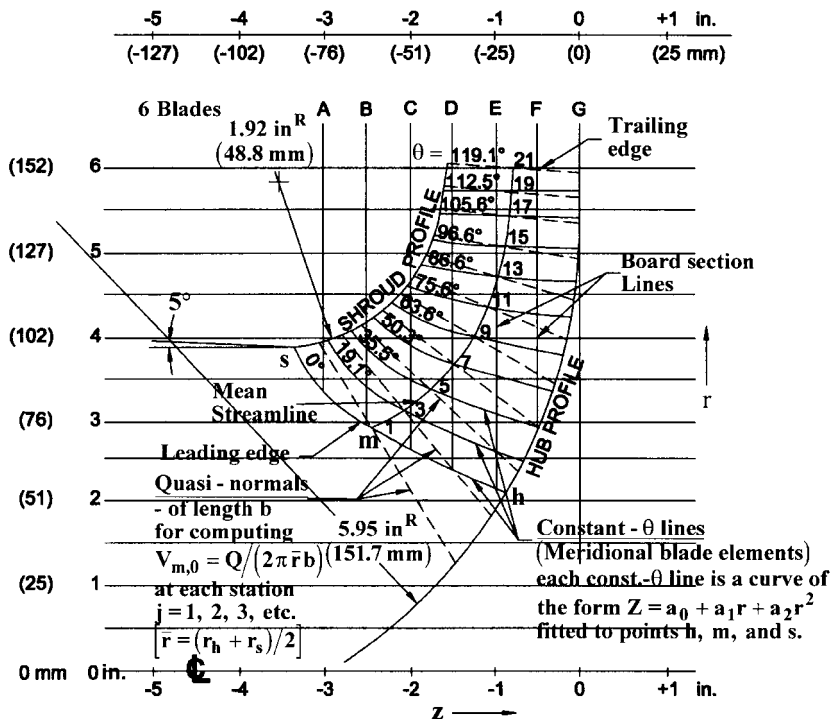


FIGURE 27 Impeller blading—meridional view (design example)

To establish the *blade shapes along the hub and shroud*, the corresponding “grid lines” of Figure 19 were found from polynomials satisfying the end conditions of blade angle and location, the  $y$ -position of the inlet end of the grid line being iterated until the desired blade wrap was obtained. In this way, different wrap angles  $\Delta\theta (= \theta_2 - \theta_1)$  can be imposed, but a tolerable resulting blade shape requires that these  $\Delta\theta$ s be not much different from the  $\Delta\theta (= 119.1 \text{ deg})$  obtained on the mean line from the method just described. In this example, it was possible to maintain  $\Delta\theta$  the same on all three construction lines. Alternatively and perhaps more consistently, the inverse approach could be applied at hub and shroud as well as on the mean line.

Regardless of which procedure is used to generate the hub, mean and shroud blade shapes—the conformal transformation method, the point-by-point method, or some combination—the *shape of the blade everywhere else* still needs to be established. To do this, the shapes of the constant- $\theta$  lines in Figure 27—called “blade elements”—must be specified. This can be done mathematically as indicated on the figure or by eye (the latter approach is widely used). Note that each constant- $\theta$  line actually lies in a different meridional plane. Thus, Figure 27 depicts a superposition of all 21 meridional planes, each containing an intersection of the blade surface and appropriately identified as having the  $\theta$ -value noted on the figure.

DIFFUSION ASSESSMENT Figure 29 is a presentation of the free-stream relative velocity distributions at the blade surfaces and halfway between. The rapid approximate method of

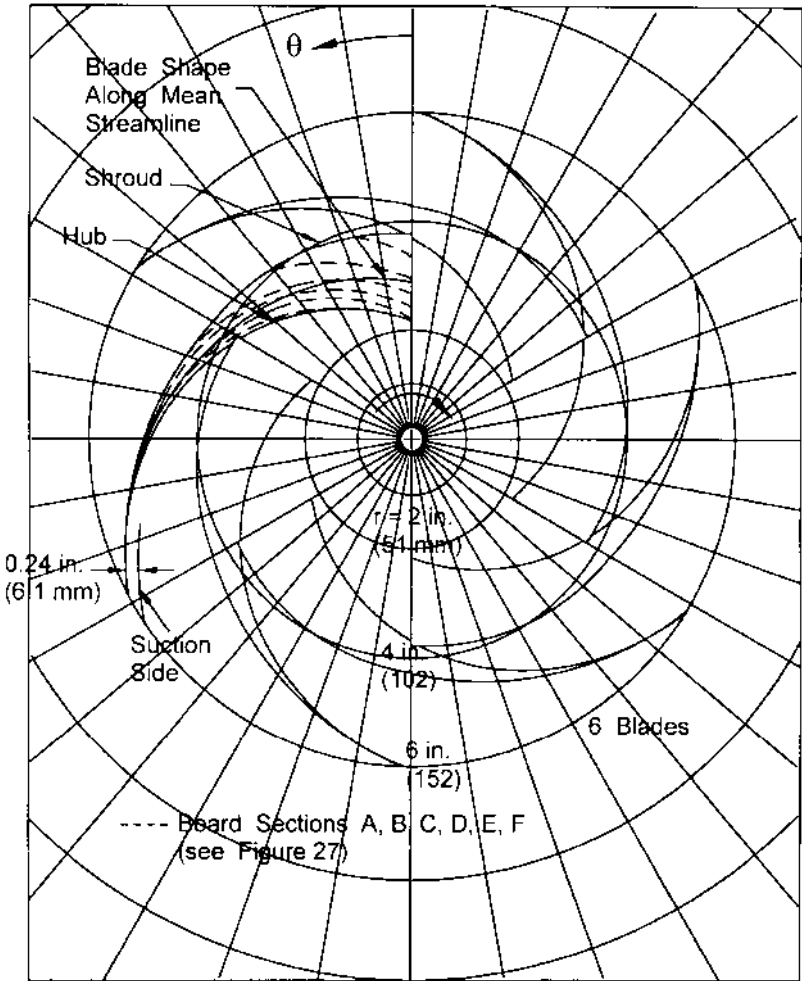


FIGURE 28 Impeller blading—polar view, showing pressure sides of the blades (design example)

Stanitz (Eq. 54) is utilized to obtain the surface  $W$ 's, the mean values of  $W$  on the mean (rms) streamline coming from the local velocity diagrams developed at each station<sup>22</sup>. The mean  $W$ 's at hub and shroud are found at the ends of the respective constant- $\theta$  lines under the assumption that the ideal head or  $UV_\theta$ -product is constant along each of these lines from hub to shroud. This is usually a fair approximation; however, a Q3D analysis (Figure 14) would yield a closer estimate of these mean  $W$ -distributions<sup>16,41</sup>. Nevertheless, the diffusion factors computed from the plotted surface velocities by means of Eqs. 59 are shown on the figure—these values are well below the 0.6 limit. This would indicate that the resulting solidity of 1.48 (originally estimated at 1.46 in Table 10) is adequate, and that the correct number of blades was chosen.

Notice also on Figure 29 that the exit value of  $W$  is significantly larger than  $W_g$ , which is consistent with the outlet velocity diagram of Figure 26b. Further, a slight jump in the mean  $W$  at the inlet is indicated; however, as the higher value of  $W$  is not sustained, it is

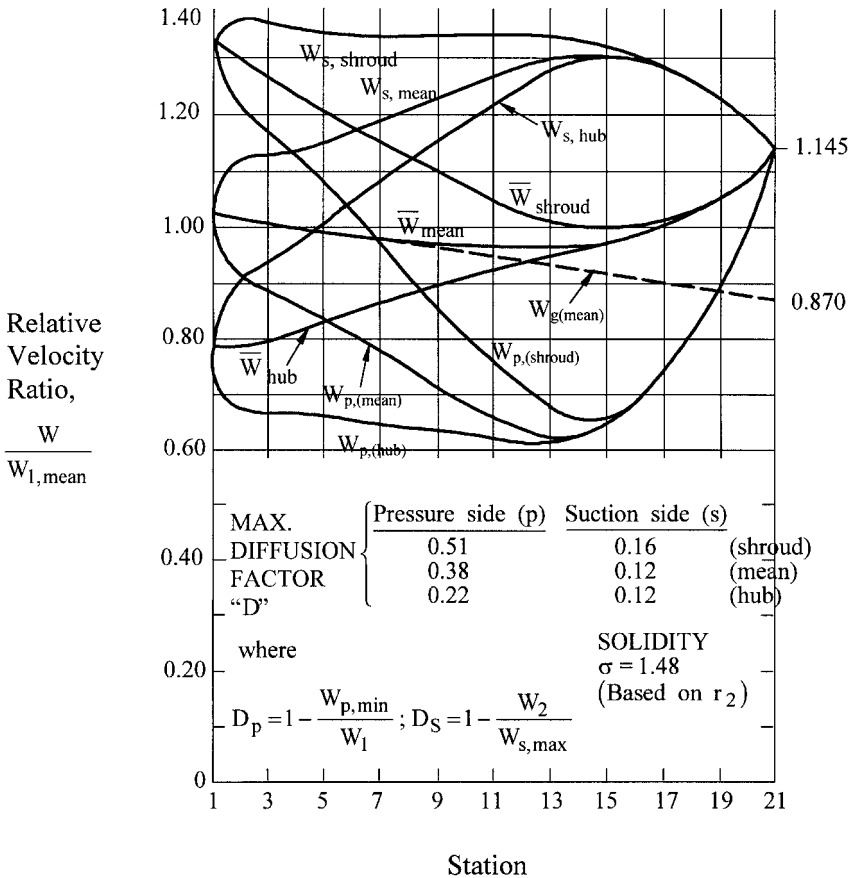


FIGURE 29 Blade surface relative velocity distributions (design example)

unlikely that it actually occurs in the 3D velocity field. Moreover, details near leading and trailing edges are not well handled by Eq. 54—a 2D blade-to-blade solution is more desirable for this type of diffusion assessment<sup>42</sup>.

**Volute Design** With the exit velocity  $V_2$  of 43.6 ft/sec (13.3 m/s) and the tangential velocity component  $V_{\theta,2}$  of 40.5 ft/sec (12.3 m/s) from Figure 26b, the volute design process is started in Table 11 using Eq. 61. This entails a choice of the radial “Gap B” of 6% of the impeller radius  $r_2$  and a tongue leading edge thickness  $t_l$  equal to 70 percent of the impeller blade thickness. These choices are not critical for a pump of low energy level such as this is, as the stresses imposed by the flow on structural elements are small. The throat area  $A_T$  is then found to be 32.60 in<sup>2</sup> (21,032 mm<sup>2</sup>) and the throat velocity  $V_T$  computes to 24.60 ft/sec (7.50 m/s), which is 56% of  $V_2$  and so represents considerable diffusion from impeller exit to throat. (The throat area  $A_T$  is the fundamental feature of a volute and acts in concert with the impeller exit area, as emphasized by Anderson<sup>6</sup> and Worster<sup>25</sup> and described in the earlier part of this section on *Designing the Collector* in terms of the intersection of the casing and impeller lines<sup>26</sup>.)

The circumferential *distribution of the volute cross-sectional area*  $A_v$  versus polar angle  $\theta_v$  from the tongue (Figure 20a) is developed in the latter part of Table 11, a final listing being presented for a) linear  $A_v$  versus  $\theta_v$  and b) constant one-dimensional angular momentum  $r_v V_v$ . This listing illustrates an earlier statement that the latter approach

**TABLE 11** Volute casing (design example)

Refer to Fig. 20

A) Throat area  $A_T$

Simultaneously solve for  $A_T$  from

$$\text{a) } r_T \frac{Q}{A_T} = 0.95 r_2 V_{\theta,2} \quad (\text{Eq. 61, using 0.95}) \quad \text{since } A_T = \frac{Q}{V_T}$$

and

$$\text{b) } r_T = r_3 + \frac{1}{2} \sqrt{A_T} + t_t \quad (\text{Fig. 20, assuming a square throat})$$

Eliminating  $r_T$  in combining (a) and (b) yields a quadratic equation in  $\sqrt{A_T}$ :

$$\text{c) } A_T \times \left( \frac{0.95 r_2 V_{\theta,2}}{Q} \right) - \frac{1}{2} \sqrt{A_T} - (r_3 + t_t) = 0$$

Taking  $r_3 = 1.06 r_2$  (i.e., "Gap B" =  $0.06 r_2$ ),  $r_3 = 6.36$  in (161.5 mm); assuming  $t_t = 0.7 t_b = 0.7 \times 0.24 = 0.168$  in. (4.3 mm); and using consistent units in (c); leads through the quadratic formula to

$$A_T = 32.60 \text{ in}^2 \quad (21,032 \text{ mm}^2)$$

Thus  $V_T = 24.60$  ft/sec (7.50 m/s)

B) Cross-sectional area

If volute cross-sectional area  $A_v$  is distributed linearly vs.  $\theta_v$ ,  $A_v$  and the radius  $r_v$  to the center of the cross section are as follows:

$$\text{d) } A_v = A_T \frac{\theta_v(\text{deg})}{360} = \frac{32.60}{360} \times \theta_v \text{ in}^2 = \frac{21,032}{360} \times \theta_v \text{ mm}^2$$

$$\begin{aligned} \text{e) } r_v &= r_3 + \frac{1}{2} \sqrt{A_v} = 6.36 + \frac{1}{2} \sqrt{A_T (\text{in}^2)} \quad \text{in} \\ &= 161.5 + \frac{1}{2} \sqrt{A_T (\text{mm}^2)} \quad \text{mm} \end{aligned}$$

If  $A_v$  is found subject to constant angular momentum with  $r_v V_v = 0.95 r_2 V_{\theta,2}$ ,

$$\text{f) } A_v = \frac{Q}{V_v} \times \frac{\theta_v(\text{deg})}{360} = \frac{Q \left( r_3 + \frac{1}{2} \sqrt{A_v} \right)}{0.95 r_2 V_{\theta,2}} \times \frac{\theta_v(\text{deg})}{360}$$

TABLE 11 Continued.

This is a quadratic equation in  $\sqrt{A_v}$ , which, when solved, gives the results for "constant  $r_v V_v$ " in the listing below,  $r_v$  being found from Eq. (c) for both this and the linear case.

Volute cross sections (design example)

$\theta_v$ deg	Linear $A_v$ vs. $\theta_v$				Constant ( $r_v \times V_v$ )			
	$A_v$		$r_v$		$A_v$		$r_v$	
	in <sup>2</sup>	mm <sup>2</sup>	in	mm	in <sup>2</sup>	mm <sup>2</sup>	in	mm
0	0.00	0	6.36*	161.5*	0.00	0	6.36*	161.5*
45	4.08	2,629	7.37	187.2	3.15	2,031	7.25	184.1
90	8.15	5,258	7.79	197.8	6.64	4,286	7.65	194.3
135	12.23	7,887	8.11	205.9	10.39	6,701	7.97	202.5
180	16.30	10,516	8.38	212.8	14.34	9,250	8.25	209.6
225	20.38	13,145	8.62	218.9	18.48	11,922	8.51	216.1
270	24.45	15,774	8.83	224.3	22.79	14,706	8.75	222.2
315	28.53	18,403	9.03	229.4	27.27	17,596	8.97	227.9
360	32.60	21,032	9.21**	234.1**	31.91	20,588**	9.18**	233.3**

\*  $r_v = r_3$  at  $\theta_v = 0$   
 \*\* transition to  $r_T = 9.38$  in (238.3 mm) and  $A_T = 32.6$  in<sup>2</sup> (21032 mm<sup>2</sup>) due to tongue thickness

duces smaller areas upstream of the throat than does the former. Frictional effects in the smaller- $A_v$  portion of the volute are less prominent using the linear approach. A CFD assessment at all flow rates can be made to guide the design choice here. Finally, the one-dimensional constant  $r_v V_v$  method can be improved upon by integrating a constant  $r V_v$  distribution over each cross section, and the proper design must satisfy also continuity<sup>26</sup>.

**Estimated Performance Characteristics** Detailed computation of hydraulic losses, together with leakage, disk friction, and other mechanical drags was done as described previously, and the results are presented in Figure 30. The method predicts the pump efficiency to be 85.5% at the design point of 2500 gpm (0.1577 m<sup>3</sup>/s), peaking at 86 percent at a 5% lower flow rate. The power consumption peaks at the design point at 77 hp (57 kW), indicating that this is a "non-overloading" design; that is, shaft power does not increase beyond this flow rate. The empirical methods reviewed earlier for shut-off head and power were applied here and blended into the one-dimensionally computed curves at half of the BEP flow rate.

The shut-off head coefficient value of 0.596 is close to the 0.585 value of Stepanoff<sup>4</sup> and is admittedly open to alteration. The rise of head from design point to shut-off is from 104 up to 161 ft (31.7 up to 49.1 m) or 55%. This percentage could be smaller and still ensure stable operation in any typical system; however, the non-overloading feature could change, the power peaking at a higher flow rate. In retrospect, the design-point head coefficient  $\psi$  of 0.385 could be larger without the diffusion-factor results of Figure 29 becoming excessive. One would conclude from this exercise that the  $\psi$ -curve of Figure 12 is conservative and could be higher. Of more significance, however, is the demonstration in this design example of the utilization of easily applied fundamental fluid dynamical analyses such as the diffusion assessment illustrated in Figure 29 as the basic arbiters of design choices such as the head coefficient, number of blades, and so on. Furthermore, the shapes of the performance characteristics are revealed.

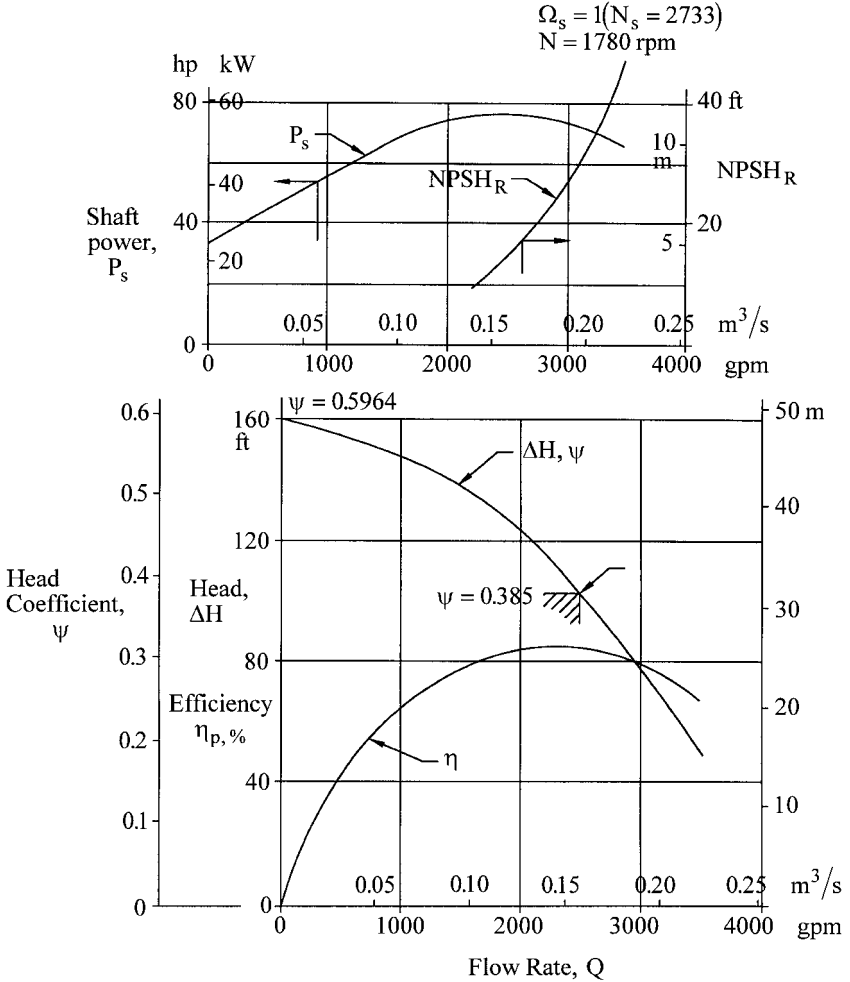


FIGURE 30 Estimated performance characteristics (design example)

The shut-off power is 34 hp (25 kW), arising from a power coefficient of 0.047 from Mockridge's correlation<sup>36</sup> for a  $b_2/D_2$  of 1.59/12 (= 40.4/304.8) = 0.1325—as found from Figure 23. This is 44% of the design-point power, a typical result. As seen in Section 2.3.1, this percentage increases with specific speed, where, of course,  $b_2/D_2$  is also larger<sup>36</sup>.

The  $NPSHR$  (=  $NPSH_{3\%}$  for this example) at off-design conditions is estimated empirically. At the higher, non-recirculating flow rates,  $NPSHR$  is related to the head required to accelerate the relative velocity within the blades to values higher than at the design point<sup>14</sup>. As stated in Section 2.3.1, operation at  $NPSH_{3\%}$  involves performance in the presence of extensive internal two-phase behavior. This is complicated by recirculation at the lower flow rates. Therefore, the full  $NPSHR$  curve in such a case usually has to be established experimentally.

## HIGH-ENERGY PUMPS

Over the past few decades, there has been a trend toward pumping machinery that concentrates more power within a given volume. This trend is driven by cost and technology improvements. The basic energy transfer relationships show that smaller size demands higher rotative speed. Thus, over the same time period, speeds of high-power pumps have been increasing. Moreover, the number of stages in multistage pumps has been decreasing. There have been spikes in these trends; the resulting pumps suffering from excessive vibration, rotor and hydraulic instabilities, component failure, and cavitation damage<sup>57</sup>. The term “high energy” has been applied to these machines, and this label can be quantified in terms of the stresses arising in critical pump components and the likelihood of an adverse mechanical response that such stress levels imply. Research has led to technical solutions for effectively controlling rotordynamic behavior and reducing unsteady hydraulic thrust and surge as well as cavitation erosion<sup>53,58,59</sup>. The resulting pump reliability improvements and life extension should enable the previous trends to continue. Being aware of the energy level enables the pump user to assess whether operation and maintenance difficulties are likely to occur after the pump is installed and running, and it enables the designer to take the appropriate measures to ensure the technical integrity of the product.

**Pressure Pulsations** Measured at the inlet or outlet port, the amplitude of the pressure pulsations can be a significant fraction of the pressure rise of the pump—especially at flow rates well below that of the BEP for the speed involved. Sources are a) the interaction of the pressure fields of the impeller and diffuser or volute, b) unsteady separated and reversed flows at impeller inlet and discharge and in the diffuser, c) cavitating flows, and d) combinations of these phenomena. Pressure pulsations presumed to exist at the impeller OD from the interaction of impeller blade-to-blade and diffuser vane-to-vane variations of pressure have been calculated by inviscid flow analysis to have a peak-to-peak amplitude that is of the same order as the static pressure rise of the impeller<sup>60</sup>. Moreover, the viscous, thicker wakes existing at lower-than-BEP flow rates (here called “low flows”) and separated recirculating fluid from both impeller and diffuser that participate in these interactions can be expected to increase the pressure pulsation amplitude at such conditions.

Figure 31 confirms these ideas, showing a bronze impeller that operated extensively at low flow. Cavitation pitting can be observed near the OD of the impeller, which means that the rarefactions of the pressure waves were below the vapor pressure of the liquid—these pressure minima therefore being below the inlet pressure to the impeller. Moreover, the bulged-out shrouds can be assumed to be the result of the repeated occurrence of the associated pressure spikes (that is, the maxima of the pressure waves) within the radial gap (“Gap B”) between the impeller blades and the diffuser vanes, the sidewall pressures on the outsides of the shrouds remaining comparatively constant. At greater values of design pressure rise than was the case for this impeller, this phenomenon creates correspondingly greater forces that have led to actual breakage of the impeller shrouds and diffuser vanes<sup>61</sup>. The cavitation seen in Figure 31, can also be observed on the leading edges of diffuser vanes, as in Figure 21 of Section 9.5, and this raises the possibility of diffuser vane breakage.

**Energy Level: Stage Pressure Rise** Even in the absence of the weakening effect of cavitation erosion, the leading edge of a diffuser vane or volute tongue is a representative, highly stressed zone within a pump that is subject to failure if the magnitude of the pressure pulsations arising from the impeller-diffuser interactions just described is sufficiently large. Thus, the hydraulically induced stresses in these vanes can be the basis for quantifying the energy level of a pump stage. In Table 12, this concept is developed into an expression for the stress in terms of the fluctuating pressure magnitude  $\delta p$  that is assumed to act across the vane leading edge as illustrated in the table. The width  $b$  of the vane is close enough to  $b_2$  of the impeller exit to utilize the relationships for  $\psi$  and  $\phi_1$  of Figure 12 to relate  $b/D$  to specific speed in Eq. (c) of the table. For similar velocity fields, the pressure pulsation magnitude  $\delta p$  is a constant multiplied by the stage pressure rise  $\Delta P_{\text{stg}}$ . Thus, for a limiting value of stress, the concept of a limiting stage pressure rise





**FIGURE 31** Damage to impeller from low-flow operation (Source: E. Makay in *Power*)

emerges in Eq. (e). The constant  $K$  is chosen from experience, which leads to the resulting Eq. (f). This relationship is plotted in Figure 32. [It will be observed that this choice for  $K$  corresponds to a limiting stress  $s$  from Eq. (d) of 6,600 psi (45.5 MPa) that would exist if  $\delta p$  were equal to  $\Delta P_{\text{stg}}$ —with  $t/D = 0.01$  and  $\varepsilon = 0.85$  as in the example.] The inverse variation with specific speed is a consequence of the greater  $b/D$  of higher- $\Omega_s$  pumps (as developed in Table 12), the wider vane introducing more stress at the juncture with the sidewalls for the same pressure loading and so imposing a lower stage pressure-rise limit. Conversely, lower- $\Omega_s$  pumps should have higher limits for  $\Delta P_{\text{stg}}$ .

Figure 32, therefore, illustrates this concept of a *limiting stage pressure rise* as a measure of the energy level of centrifugal pumps, the basis being a limiting stress level in a critical component of the pump. Starting with stress at other locations in the pump leads to similar results. To provide perspective, specific examples of pumps that by this definition are in the *high-energy domain* are plotted on the figure. These data points are taken from Table 13, which contains information for several well-known liquid rocket engine turbo pumps<sup>62,63,64</sup> and for some representative high-energy electric utility boiler feed pumps<sup>53,57</sup>.

The last column in Table 13 is another, more general way of comparing the energy level of these machines; namely, the *torque per unit volume*, which also has the dimensions of stress. For fixed ratios of stage width, casing OD, and other dimensions to impeller radius  $r$  ( $= r_2$ ), torque per unit volume differs from the listed values of  $\text{torque}/r^3$  by a factor. The actual torque per unit volume therefore ranges from one-half to one-sixth of the tabulated

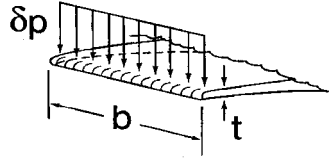
**TABLE 12** Hydraulically induced stress levels

- Stress at juncture of diffuser vane leading edge with sidewall:

$$s = \frac{\delta p b^2}{2t^2} = \frac{(\delta p/2)(b/D)^2}{(t/D)^2} \quad (a)$$

- From Fig. 12 and Eq. 36:

$$\frac{b}{D} = \frac{Q}{V_{m,2} 2\pi r_2 \varepsilon D} = \frac{Q}{\Omega r_2 \frac{V_{m,2}}{\Omega r_2} 4\pi r_2^2 \varepsilon} = \frac{Q_s}{\phi_i 4\pi \varepsilon} \quad (b)$$



- From Eq. 50:

$$\frac{b}{D} = \Omega_s^2 \psi^{3/2} / (4\pi \phi_i \varepsilon) \quad (c)$$

- With  $\psi \approx 0.383/\Omega_s^{1/3}$  and  $\phi_i \approx 0.1715\sqrt{\Omega_s}$

the stress Eq. (a) becomes, with Eq. (c)

$$s = \frac{\delta p \times \Omega_s^2}{165 \times (t/D)^2 \varepsilon^2} \quad (d)$$

- Example for  $t/D=0.01$ ,  $\varepsilon=0.85$ ,  $\Omega_s=0.6$  and  $\delta p=1000$  psi (6.895 MPa):

$$s = \frac{1000 \times (0.6)^2}{165 \times (0.01)^2 \times (0.85)^2} = 30,198 \text{ psi (208.2 MPa)}$$

- For  $\delta p$  being proportional to  $\Delta P_{\text{stg}}$ , and for a fixed geometry and a given limiting value of stress, Eq. (d) becomes

$$\Delta P_{\text{stg}} = K/\Omega_s^2 \quad (e)$$

- Experience leads to a choice of  $K$  such that

$$\Delta P_{\text{stg}} = \frac{78.72}{\Omega_s^2} \text{ psi} = \frac{0.5427}{\Omega_s^2} \text{ MPa} \quad (f)$$

torque/ $r^3$ , depending on the casing or barrel thickness, and so on. However, as has been demonstrated, the critical stresses are more closely associated with the impeller OD, which makes comparison of the tabulated values more relevant. Thus, a pump with high torque/ $r^3$  can be expected to have correspondingly high local internal stresses. The maximum values listed, namely for the high-pressure propellant pumps on the RD-170 (Russian) and SSME (U.S. Space Shuttle) engines, tend to explain the high level of research and development that was necessary to successfully deploy these machines. Illustrations of some of these rocket engine pumps can be found in Section 9.19.2. Similarly, Section 9.5

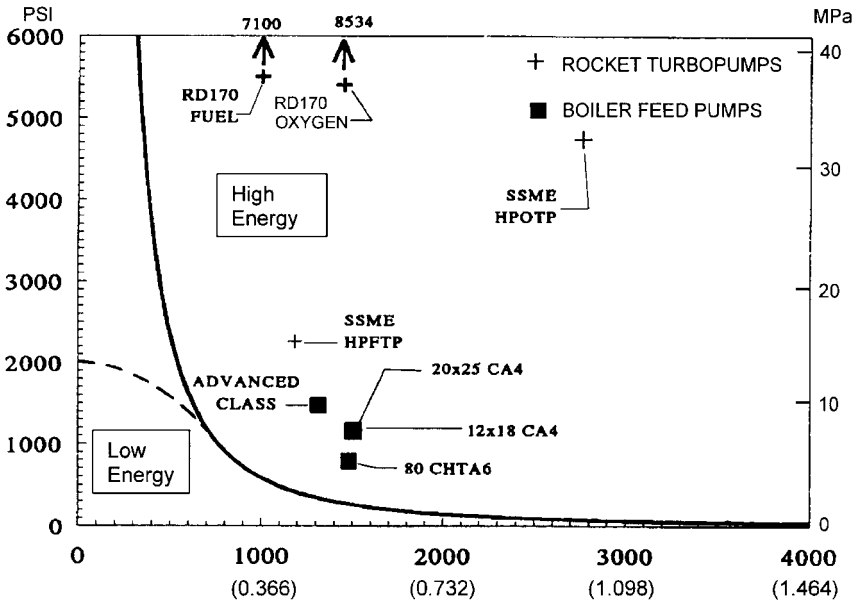


FIGURE 32 Pump energy level defined in terms of stage pressure rise

provides examples of high-energy boiler feed pumps: the massive, barrel-type construction of these machines is illustrated in Figure 18. Specifically, the first boiler feed pump listed in Table 13 is the sole feed pump supplying the steam generator of a super-critical 1300 MW electric generating unit and consumes nearly 50 MW of shaft power. It can be seen in Figures 7 and 20 of Section 9.5.

For pumps in the *low-energy domain* of Figure 32, normal design and manufacturing practices result in a more benign mechanical response to the abnormal fluid phenomena discussed here. However, for locations other than the diffuser entrance, which was the basis for the development of the figure, limiting stresses could be reached at considerably lower values of stage pressure rise. For this reason, the dashed line is offered as the upper limit of the low-energy domain; however, a thorough analysis of the stresses in any given application is the ultimate determinant of all the limits suggested in Figure 32 and of the acceptability of the design. It can now be seen that the design example treated earlier in this section is of the low-energy variety; therefore, the special design problems treated here and further on are of relatively little concern in such pumps. On the other hand, if the curve in Figure 32 were extended to much *higher specific speeds*, it would be found that many existing, large, high- $\Omega_s$ , low-head pumps are high-energy machines by this stress-related definition. It is therefore not surprising that such pumps generally require full stress and modal analyses to identify possible destructive resonances and stresses.

**Fluid/Structure Interactions** With the dimensions of pump energy level identified, the next step is to continue the examination of the problems mentioned previously and the methods that have become available for solving them. Attention is focused on hydraulic phenomena because, as the previous discussion of pressure pulsations implies, most of the adverse mechanical behavior exhibited by pumps originates from the behavior of the internal flow field. Excessive measured vibrations, material erosion, and component failures are often the external symptoms of fluid/structure interaction phenomena that are fundamentally explained from a hydraulics perspective. In addition to the hydraulically

TABLE 13 Data on high-energy pumps\*

Pump	No. of stages	Speed rpm	Flow rate gpm (m <sup>3</sup> /s)	Head/stg ft (m)	$\Delta P$ /stg psi (MPa)	Specific Spd N <sub>s</sub> (Ω <sub>s</sub> )	Torque/r <sup>3</sup> psi (MPa)
<b>Liquid Rocket Propellant Turbopumps</b>							
Saturn V Booster – F1 Engine: Oxygen	1	5,490	25,080 (1.582)	3,100 (945)	1,530 (10.5)	2,095 (0.767)	371 (2.6)
Saturn V Booster – F1 Eng: Fuel (RP1)	1	5,490	15,640 (0.986)	5,100 (1,555)	1,810 (12.5)	1,130 (0.413)	172 (1.2)
Space Shuttle Main Engine: Oxygen (= SSME HPOTP)	1	31,100	7,240 (0.457)	9,700 (2,957)	4,800 (33.1)	2,700 (0.988)	1,431 (9.9)
Space Shuttle Main Engine: Fuel (H <sub>2</sub> ) (= SSME HPFTP)	3	37,400	16,300 (1.028)	66,700 (20,330)	2,280 (15.7)	1,150 (0.421)	200 (1.4)
RD-170 – Oxygen	1	13,850	25,008 (1.578)	17,300 (5,273)	8,534 (58.8)	1,448 (0.530)	1,521 (10.5)
RD-170 – Fuel (= RP1)	1	13,850	14,485 (0.914)	20,000 (6,096)	7,100 (49.0)	992 (0.363)	698 (4.8)
<b>Boiler Feed Pumps</b>							
20x25 CA-4 (IDP)	4	4,160	21,620 (1.364)	3,000 (914)	1,169 (8.1)	1,509 (0.552)	128 (0.9)
12x18 CA-4 (IDP)	4	5,800	11,000 (0.694)	3,000 (914)	1,169 (8.1)	1,500 (0.549)	130 (0.9)
80CHTA-6 (IDP)	6	5,800	6,250 (0.394)	2,100 (640)	820 (5.7)	1,479 (0.541)	87 (0.6)
Advanced Class (Sulzer)	2	6,500	9,510 (0.600)	3,800 (1,158)	1,480 (10.2)	1,312 (0.480)	136 (0.9)

\*Notes to this table: Flow rates apply to the pump inlet. RD-170 pump data derived from Sutton<sup>62</sup> and Advanced Class boiler feed pump data from Ref. 57. Remaining data derived from Table 1 of Section 9.19.2, NASA reports<sup>63,64</sup> and from information supplied by Flowserve Corporation.<sup>65</sup>

induced stresses in the pump structure that culminated in the domain definition of Figure 32, these phenomena encompass a) blade-vane interactions, b) recirculation, c) anomalous axial thrust behavior, and d) cavitation.

In order to illustrate the methods for dealing with the problems created by these fluid/structure interactions, a sample suction stage of a high-energy multistage pump is utilized as the quantifying focus in each case. Table 14 contains the conditions and essential features of this machine, a meridional view of which is shown in Figure 33. As with the earlier design example, this stage has been designed in accordance with the procedures outlined for that example. This includes the velocity diagrams shown in the figure, as well

**TABLE 14** Data for high-energy pump suction stage**A. Design Inputs**

Fluid: Boiler feed water at 350°F (177°C) ⇒ sp. gr. = 0.89, $\nu = 0.17$ cs.	
Flow rate, $Q$ , gpm ( $\text{m}^3/\text{s}$ )	20,000 (1.262)
Head rise, $\Delta H$ , ft (m)	3,000 (914.4)
Rotative speed, $N$ , rpm	4,700
Outlet flow coefficient, $\phi_2$ (Figure 12)	0.1328
Head coefficient, $\psi$ (Figure 12)	0.455
Specific speed, $\Omega_s$ ( $N_s / n_q$ )	0.6 (1640/32)
Inlet flow coefficient, $\phi_e$	0.3 (=tan 16.7 deg.)
Number of Impeller blades, $n_b$	7
Number of Diffuser vanes, $n_v$	9

**B. Calculated Performance Data**

## 1. Efficiency

a) BEP of 20,000 USgpm (1.2618  $\text{m}^3/\text{s}$ )

$$\eta = \eta_p = 0.877 \quad (\text{vs. } \eta = 0.8682 - \text{from Fig 10, for } X=1)$$

$$\eta_{hy} = 0.900$$

$$\eta_m = 0.985$$

$$\eta_v = 0.989 \quad [216 \text{ gpm } (0.0136 \text{ m}^3/\text{s}) \text{ front ring leakage; rear ring leakage included in } \eta_{hy}]$$

b) At 50% Flow :  $\eta_p = 0.693$  (= 0.79 of  $\eta_{BEP}$  ; 0.8 is typical)

## 2. Head Rise

$$\Delta H_{BEP} = 3000 \text{ ft. } (914 \text{ m}) \Rightarrow \psi = 0.455$$

$$\Delta H_{shutoff} = 3697 \text{ ft. } (1127 \text{ m}) \Rightarrow \psi_{s/o} = 0.560$$

$$\Delta H\text{-vs-}Q \text{ curve stability indicator, } \Delta H_{s/o}/\Delta H_{BEP} = 1.23 \text{ (doubtful if less than 1.2)}$$

## 3. Power

$$P_{s,BEP} = 15,376 \text{ hp } (11,466 \text{ kW}) \sim \hat{P} = 0.0571$$

$$P_{s,SHUTOFF} = 6,144 \text{ hp } (4,583 \text{ kW}) \sim \hat{P}_{s/o} = 0.0228 \text{ (= } 0.01966 \times 1.16 \text{ from Fig. 23)}$$

$$\uparrow$$

$$= K \text{ for } \frac{b_2}{D_2} = 0.0779$$

as the design of the eye, the hub and shroud profiles, and the blading. A preliminary design was also made of the vaned diffuser and return vanes, following the guidelines presented in the foregoing *Design Procedures* subsection. The result is a representative machine to which the following paragraphs continually refer.

**Blade-Vane Combinations** Certain numerical combinations of impeller blades and diffuser vanes (or inlet guide vanes, where they are employed) have been shown to have acoustic consequences that can exacerbate the pressure pulsations arising from the interaction of impeller and diffuser flow fields. Bolleter reviewed the types of interactions that can occur and the consequences with regard to pressure pulsations and resonance<sup>33</sup>. These

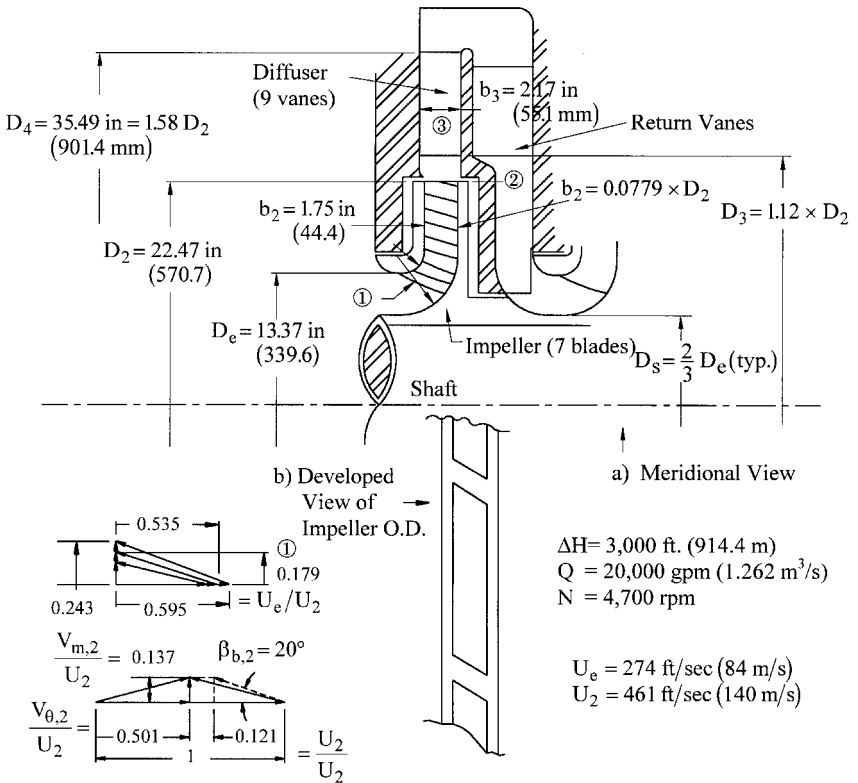


FIGURE 33 Sample suction stage of high-energy multistage pump

types are associated with the integer difference  $m$  between the multiples of the number of impeller blades and the number of diffuser vanes, as explained in Table 15. To check the blade-vane combination, one simply forms a matrix of the multiples as shown and lists the difference in each cell.

To illustrate the method, rather than use the pump of Table 14, a different example is chosen in order to dispel the notion that one can always use two different prime numbers for blade-vane combinations. This is an existing case of a 60,000 hp (45 MW) single-stage pump of  $\Omega_s = 0.6$  ( $N_s = 1640$ ) and  $\Delta p = 357 \text{ psi}$  (2.46 MPa), which has 7 impeller blades and 13 diffuser vanes<sup>65</sup>. Notice that  $m = 1$  in the second order of impeller blade number, which means there should be pressure pulsations at  $2 \times 7 \times \text{rpm}/60 \text{ Hz}$ . In fact, this pump has exactly this vibration and pressure pulsation frequency in the field, not least because the pump is operating at just the right speed for the acoustic waves emanating from successive interaction points to reinforce each other in producing unacceptable pressure pulsations.

Even with this simple method, the final choice of the blade-vane combination is usually a compromise. For example, the method shows that all double-volute pumps have  $m = 0$  or 1 in the first order of impeller blade number, depending on whether this number is even or odd.  $m = 0$  means that all the blades or vanes are interacting at the same instant, a consequence of which is torque ripple. High-energy volute pumps exist for both even and odd cases—quite large gaps between blades and vanes (= “Gap B”) are employed to mitigate these effects.

The reader who checks the pump of Table 14 by this method will find that  $m = 2$  in the first order of both blades (7) and vanes (9) but that  $m \neq 0$  everywhere else in the matrix.

**TABLE 15** Choosing vane combinations to minimize pressure pulsations<sup>33</sup>

1.  $Z_i$  is the number of impeller blades.
2.  $Z_d$  is the number of diffuser vanes.
3. Each vane combination produces interacting pressure fields between the blade rows.
4. These fields form “m” rotating “nodal diameters”, producing unsteady loads
5. The value of “m” determines the nature and severity of these loads.
6. “m” is the difference between  $(p \times Z_i)$  and  $(q \times Z_d)$ , where p and q are integers.
7. To find “m”, one sets up a matrix of diffuser vanes and their multiples vs. impeller blades and their multiples or “orders”. A minimum of the first three orders should be used. This is illustrated as follows for an impeller with 7 blades ( $Z_i=7$ ) and a diffuser with 13 vanes ( $Z_d=13$ ):

		Impeller blades and their multiples:			
		p=1 7(=Z <sub>i</sub> )	p=2 14	p=3 21	p=4 28
Diffuser vanes and their multiples:		Differences “m” between $(p \times Z_i)$ and $(q \times Z_d)$ are give below:			
q=1	13(=Z <sub>d</sub> )	6	1	8	15
q=2	26	19	12	5	2
q=3	39	32	25	18	11

The significant values of “m” are 0, 1 and 2. The lower the order of either the impeller blades or the diffuser vanes, the stronger is the interaction. The responses that occur for these “m” values are as follows:

- m = 0 - strong pressure pulsations and fluctuating axial loads and torsional forces.
- m = 1 - pressure pulsations and fluctuating radial loads.
- m = 2 - small pressure pulsations and a chance of resonance of the impeller about the two nodal diameters - at a frequency equal to the value of  $q \times Z_d$  times the rotational frequency (rpm or rps)

In this example,  $m = 1$  in the second order of the impeller blades (i.e.,  $p=2$ ); thus, the frequency of the resulting disturbances will be twice that of blade passing frequency  $p \times Z_i \times \text{rpm}$  or  $2 \times 7 \times \text{rpm}$  cycles per minute or  $2 \times 7 \times \text{rpm}/60$  Hertz. This is therefore a poor vane combination and should be avoided - especially for such low orders of vane number; i.e., for such small values of p and q, (Here,  $p=2$  and  $q=1$ .) In general,  $m = 0$  and 1 should be avoided altogether, and  $m = 2$  should be avoided in the lower orders.

$m = 1$  occurs only in the highest orders of both and should therefore be of little consequence. Checking whether 10 or 11 vanes would be better yields  $m = 1$  in the third order of impeller blades and second order of diffuser vanes, which is probably less desirable than  $m = 2$  in the first orders. Therefore, Figure 33 shows a value of “Gap B” that is 12 percent of the impeller radius, which should provide adequate protection from pressure pulsations and excitations of resonance. (The gaps at the impeller OD will be discussed further on.)

**Recirculation** Separation and stall of the fluid flowing in the passages of impellers and diffusers occurs at low flow because of the incidence and large reduction in the one-dimensional velocity relative to the passage that happens at low flow. This and the con-

sequent recirculation patterns in the impeller were discussed and illustrated in Figure 6. Fischer and Thoma<sup>66</sup> visually observed and recorded the flow patterns, finding that as flow rate is reduced, wakes on the suction side of all blades thicken until they occupy half the passage width at half the BEP flow rate. At lesser flow rates, the wakes continue to thicken but become irregular, stalling in one passage and not the others—the stall pattern moving into and out of adjacent passages and so rotating relative to the impeller. As shut-off is approached, this rotating pattern is accompanied by reversed flow emerging from the inlet of the stalled passage. Fraser, working with typical impeller geometries, formulated rules for computing the flow  $Q_{SR}$  at which this reversal occurs as  $Q$  is reduced at constant speed<sup>67</sup>. His expressions, found further on, include the effect of impeller eye size on  $Q_{SR}$ . As one might expect, a pump with an eye diameter approaching that of the impeller OD will have  $Q_{SR}$  approaching  $Q_{BEP}$ . At  $Q < Q_{SR}$ , the impeller flow patterns are highly unsteady—as is usually the case with massively separated flows—creating non-synchronous, low-frequency or random pressure pulsations, the resulting shear layers between the reverse-flowing and in-flowing fluid having vortices with locally low pressures so cavitation can also exist. Fraser also quantified the flow rate  $Q_{DR}$  below which impeller discharge recirculation exists. Forces from such motion can cause fatigue failure of the impeller blades, diffuser vanes or volute tongue, cavitation erosion also playing a part as in Figure 31. In Section 2.3.2, Fraser describes the identification and consequences of recirculation in detail, the more general designation  $Q_R$  referring to either  $Q_{SR}$  or  $Q_{DR}$ , depending on whether  $Q$  is between or below both.

The ability for pumps to operate with any form of separation; stall; or, worse, flow reversal (recirculation) depends on the energy level. This can be approximately quantified, as outlined under the subject of *Minimum Flow Limits* further on, which include consideration of accompanying cavitation activity.

**Axial Thrust Response to Recirculation** Discharge recirculation usually involves backflow from the diffuser, itself containing oscillating flow patterns and rotating stall. Fluid emerging from the diffuser will be spinning opposite to the direction of rotation, such fluid having a major effect on the sidewall gap flows as it joins the leakage flows described under *Predicting Axial Thrust*. As this fluid invades the sidewall gaps, it can slow or virtually cancel the usual positive swirling of the gap fluid. Iino, Sato, and Miyashiro experimentally observed and recorded this behavior, which was exaggerated by shifting the impeller axially and by changing the ring clearances<sup>68</sup>.

An added, not unexpected effect is that as  $Q$  is reduced below  $Q_{DR}$ , the invading flow from the diffuser can favor the front or back side of the impeller and then *switch sides* upon further reduction of  $Q$ . This effect is clearly seen in the experimental thrust-versus- $Q$  plots of Figure 34, the impellers having been shifted as just described. Depicted there is the resulting net load on the axial thrust bearing of an eight-stage, 3600-rpm diffuser pump that had a cylindrical balancing drum (not a self-compensating balancing disk). The drum was sized so as not to completely eliminate the thrust—in order to avoid thrust reversals. The solid lines are the predicted net thrust according to the methods outlined in Table 4 for three axial positions of the impeller. The large excursions in net thrust were eliminated by restricting the entry of the invading diffuser backflow into the sidewall gaps—through a tightening of the gap between the shrouds of impeller and diffuser (Gap “A”) in Figure 35. Gap “A” is not effective unless the “overlap” of the two mating shrouds is from four to six times the gap dimension<sup>61</sup>. Moreover, if Gap “A” is minimized, this can exaggerate the blade-vane interactions, making it necessary to open up Gap “B” more than would be necessary were Gap “A” not minimized<sup>69</sup>.

A further possibility that has been observed in a single-stage double-suction pump is the *unsteadiness* of impeller discharge recirculation and, most likely, of the diffuser or volute backflow. The side-to-side switching just mentioned appears in Figure 36 to be happening as a function of time as well as of flow rate  $Q$ , as evidenced by the axial motion, which is accompanied by discharge pressure pulsations. The “fix” mentioned in the figure was, again, mainly minimizing Gap “A.”

Closing Gap “A” and opening Gap “B” are procedures that have been widely and successfully applied in high-energy pumps, which usually work well at BEP but run into difficulties at low flow<sup>69</sup>. The procedures have proven to cure the thrust and pressure



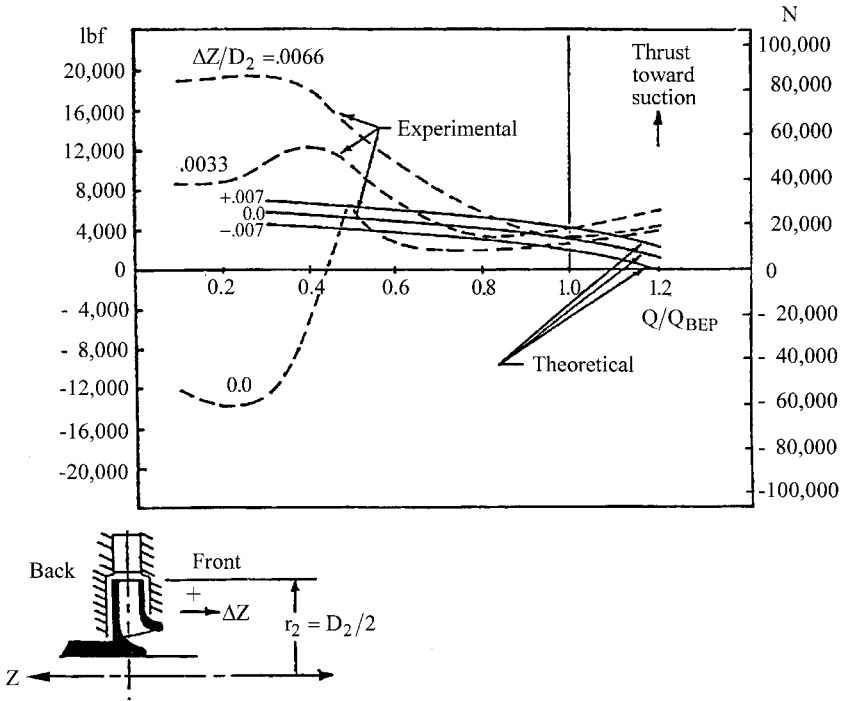
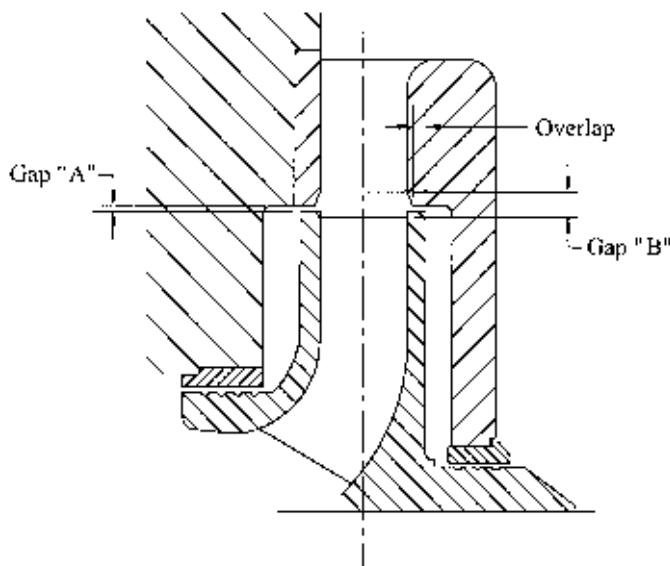
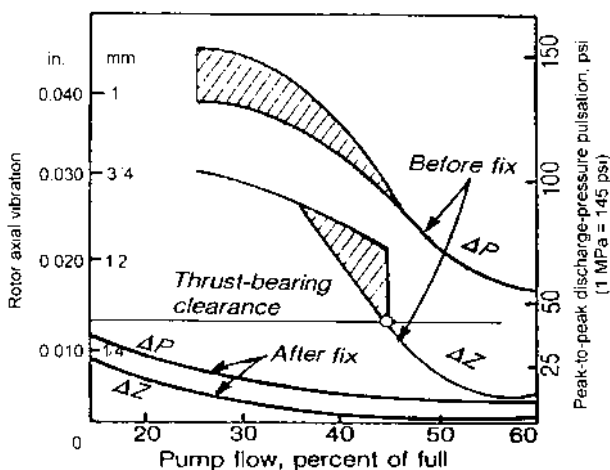


FIGURE 34 Axial thrust response to recirculation. (Source: Flowserve Corporation)

pulsation behavior just described and also improve the low-flow performance curve shape<sup>65</sup>. The results are high-energy pumps that can operate smoothly over a wider range of flow rate than—in many cases—was originally expected or specified. Nevertheless, the higher the energy level, the more intolerable is any unsteadiness and pressure pulsation activity.

**Minimum Flow Limits** Because the intensity of pressure pulsations and the accompanying vibrations can increase beyond acceptable limits as flow rate is reduced at constant speed below the BEP flow, or more specifically, below  $Q_R$ , expressions for how low  $Q/Q_{BEP}$  can be without exceeding these limits have been developed. Manufacturer and user groups such as the Hydraulic Institute (HI), the International Standards Organization (ISO), and the American Petroleum Institute (API) have specified vibration limits that must be met at what is usually called at the minimum continuous stable flow (*MCSF*) or simply  $Q_{min}$ . In an attempt to answer the question of how far into the recirculation zone (where  $Q < Q_R$ ) an operator can take a pump before reaching the *MCSF*, Gopalakrishnan proposed a general rationale for computing  $Q_{min}$  that takes the energy level into account—through the flow rate and rotative speed of the machine<sup>70</sup>. These two quantities imply the blade tip speed at the inlet of the impeller. (Through typical ratios of impeller OD to eye diameter, this also implies the OD tip speed and therefore the head, the energy level having been defined in Figure 32 in terms of stage pressure rise  $\Delta p_{stg}$ .) The theory for this method is defined in Part A of Table 16, in which  $Q_{min}$  is computed as the product of a series of K-factors multiplying the value of  $Q_R$ , which is computed according to Fraser's earlier development<sup>67</sup>. Conceptually, the product of these factors approaches unity in the maximum-energy case, where the instabilities accompanying any recirculation at all are

FIGURE 35 Gaps at impeller periphery<sup>61</sup>FIGURE 36 Eliminating unsteady thrust and pressure pulsations (Source: E. Makay in *Power*.)

significant. Conceivably, this product could exceed unity at the highest energy levels, as separation and stall and the attendant unsteadiness must occur—as  $Q$  is reduced—before the backflows that characterize  $Q_R$ , which was observed by Fraser as the value of flow rate for the onset of recirculation (see Section 2.3.2).

$K_1$  and  $K_3$  are given in Table 16 as equations that have been curve-fitted to speed/flow rate- and  $NPSH$ -effect charts that appeared in Gopalakrishnan's presentation<sup>70</sup>. This includes the ability to enter any speed (rpm) into the computation for  $K_1$ , only 3500 and

1800 rpm having explicitly appeared in the charts. *NPSH* plays a role in the determination of  $Q_{\min}$ —through the factor  $K_3$ —because of the exacerbation of the unsteadiness and pressure pulsations due to dilation of the cavities in the two-phase internal flows that exist for any value of *NPSH* that is less than the inception  $NPSH_i$ . (See the ensuing cavitation discussion and the description in Section 2.3.1 that accompanies the definition of *NPSH*-limits.)

As an example, the minimum flow of the high-energy pump suction stage of Table 14 and Figure 33 is computed in Part B of Table 16. (The value of  $R$  for the calculation of  $K_3$  is taken from Table 18.) This machine has the relatively high energy level of some of the boiler feed pumps shown in Figure 32 and listed in Table 13. Thus it is not surprising that the resulting value of  $Q_{\min}$  is 90% of  $Q_R$  (which equals  $Q_{SR}$ , as is typical) and 48.5% of the BEP flow rate. This is indicated on Figure 37, in which the computed performance curves

**TABLE 16** General method for computing minimum flow: quantifying the energy-level effect on  $Q_{\min}$  relative to  $Q_R^{70}$

A) Theory

$$Q_{\min} = Q_R \cdot K_1 \cdot K_2 \cdot K_3 \cdot K_4 \cdot K_5, \text{ or } Q_R, \text{ whichever is smaller (i.e., product of } K\text{'s } \leq 1)$$

$$Q_R = \begin{cases} Q_{SR} & \text{if } D_e \geq 0.5 D_2 \\ Q_{DR} & \text{if } D_e \leq 0.5 D_2 \end{cases}$$

$$Q_{DR} = \pi D_2^2 \cdot b_2 \cdot \frac{\Omega}{2} \cdot \overline{C_{DR}}$$

$$\overline{C_{DR}} = -0.01 + \beta_{b,2} \circ / 218.75$$

$$Q_{SR} = \pi \Omega r_e^3 \left( 1 - \frac{D_s^2}{D_e^2} \right) \cdot \overline{C_{SR}}$$

$$\overline{C_{SR}} = \tan \beta_1 \cdot \left\{ 1 - 0.2091 \cdot (\beta_1 \circ - 9.5)^{0.4} \right\}$$

$$K_1 = \left[ 0.06862 \times \left( \frac{N - 1800}{1700} \right) \right] + Y + 0.3843 \log_{10} Q$$

$$Y = \begin{cases} -0.4529 & \text{for } Q \text{ in gpm} \\ +1.1612 & \text{for } Q \text{ in } m^3/s \end{cases}$$

$K_2 =$  Specific gravity

$$K_3 = \left\{ \begin{array}{l} 0.6 + 0.4 \times \left[ \frac{1}{3} \left( \frac{4}{R} - 1 \right) \right]^{1.1} \quad \text{Pump with shaft through eye} \\ 0.7 + 0.3 \times \left[ \frac{1}{3} \left( \frac{4}{R} - 1 \right) \right]^{1.1} \quad \text{End-suction pump} \end{array} \right\} \quad R = \frac{NPSH_A}{NPSH_{3\%}}$$

$$K_4 = \begin{cases} 1 & \text{Continuous operation at minimum flow} \\ 0.7 & \text{Operation at minimum flow less than 25\% of total operating time} \end{cases}$$

$K_5 = 1$  No specific mechanical design margins

**TABLE 16** Continued.

B) Results for Sample High-Energy Pump Suction Stage (See Fig. 33)

$$Q_R = Q_{SR}, \text{ since } D_e \geq 0.5 D_2$$

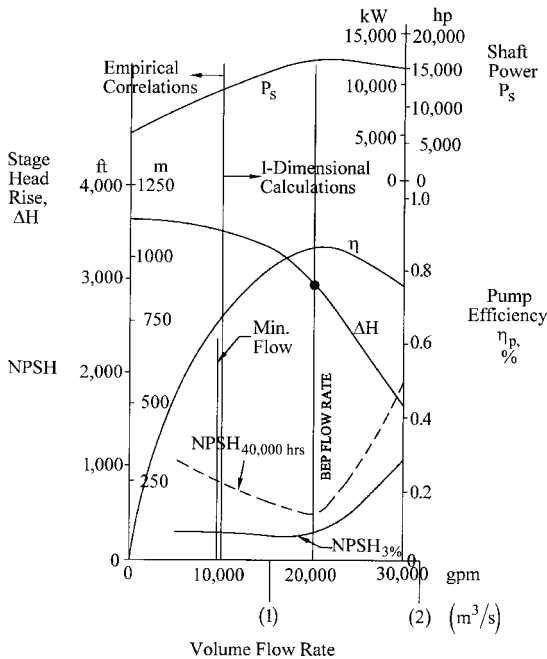
$$Q_{SR} = \pi \Omega r_e^3 \left( 1 - \frac{D_s^2}{D_e^2} \right) \cdot \overline{C}_{SR} = \pi \times 4700 \frac{\pi}{30} \times \left( \frac{6.6855}{12} \right)^3 \cdot \left( 1 - \frac{2^2}{3^2} \right) \times \overline{C}_{SR} \frac{\text{ft}^3}{\text{sec.}}$$

$$\text{and } \overline{C}_{SR} = 0.3 \cdot \left\{ 1 - 0.2091 \cdot (16.7 - 9.5)^{0.4} \right\} = 0.1618$$

$$Q_{SR} = 24.03 \text{ ft}^3/\text{sec} = 10,785 \text{ gpm } (0.6804 \text{ m}^3/\text{s}) = 0.540 \times Q_{BEP}$$

$$K_1 = 1.317 ; K_2 = 0.89 ; K_3 = 0.768 ; K_4 = 1 ; K_5 = 1$$

$$Q_{\min} = 10,785 \times 0.9002 = \underline{9,709 \text{ gpm } (0.613 \text{ m}^3/\text{s})} = 0.485 Q_{BEP}$$



**FIGURE 37** Estimated performance of high-energy pump suction stage

of this pump are displayed. (See Part B of Table 14 for the main elements of these performance predictions.) However, some of the remedies that have been discussed in this section to counter the adverse effects of high-energy pump phenomena can reduce  $Q_{\min}$  to lower values than this. In fact, the method contains the flexibility to take into account such improvements through the factor  $K_5$ .

In computing  $Q_{SR}$ , the angle  $\beta_1$  is called for. This is approximated by the inlet flow coefficient  $\phi_e = 0.3$  from Table 14, which corresponds to a nominal inlet tip flow angle of 16.7 deg. The actual flow angle (and blade angle) at that location is slightly larger due to the hub-to-shroud variation of the incoming meridional velocity as assumed in the development of the inlet velocity diagrams of Figure 33. This will have a small effect on the results, depending on how one interprets “ $\beta_1$ .” In this regard, as can also be appreciated from the choices that must be made for the  $K_s$ , the method of Table 16 is not precise; however, it is a useful indicator of what the user and designer can expect in determining the operating range of a pump.

The above general theory for computing minimum flow is inclusive of all types of centrifugal pumps and has found application especially for high-energy pumps, which can be difficult to evaluate precisely in the varying circumstances of installation and operation in which they are usually applied. The judgments that must be made in order to apply the method of Table 16 can be largely avoided if actual data for  $Q_{min}$  are available. It would in fact be a monumental task to establish precise limits for all pump types and operational envelopes. Nevertheless, the effect of energy level on *MCSF* has been found experimentally for several classes of API process pumps through extensive testing. From this, Heald and Palgrave have developed a method for computing the minimum flow of these pumps as follows<sup>71</sup>:

$$Q_{min} = MSCF = \frac{K_7}{100} K_M \times Q_{BEP} \tag{68}$$

where

$$K_7 = K_7(\text{rpm, configuration, } N_{SS}) \tag{69}$$

and

$$K_M = K_M[(NPSH_A/NPSH_R)_{BEP}, \text{ fluid}] \tag{70}$$

Obtained from Figure 38, the factor  $K_7$  accounts for the effects of speed and configuration. As used in that chart—and in Eq. 69, the term *suction-specific speed*  $N_{ss}$  (or  $\Omega_{ss}$ )

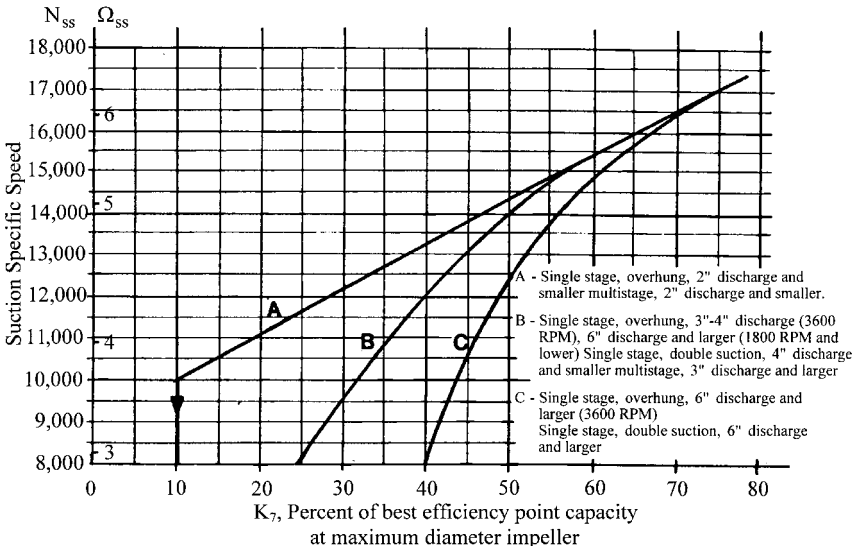


FIGURE 38 Minimum continuous stable flow (MCSF) for process pumps<sup>71</sup>

does not mean that  $NPSH$ -effects are also included; rather, this expresses the fact that the impeller design is affected by the designer's choice of  $N_{ss}$  as can be seen in the case of the earlier *Design Example*, beginning in Table 6. This leads immediately in Table 7 to the inlet flow coefficient  $\phi_e$  (through the  $NPSH$ -correlations of Table 1) and the impeller eye diameter  $D_e$  or radius  $r_e$ . Following on from the discussion of *Recirculation*, the ratio  $Q_{SR}/Q_{BEP}$  can be expected to increase with eye size or  $D_e/D_2$ . Being strictly based on experiments, the Heald and Palgrave method does not deal explicitly with  $Q_{SR}$  or  $Q_{DR}$ , but one can see from Eq. 38 that this principle is operative: Higher- $N_{ss}$  pumps require greater  $MCSF$ . Before this fact was clearly understood, the trend was to design for greater  $N_{ss}$ —in order to increase suction capability of these pumps. When operators ran them back to the same low flows as they had done with earlier pumps designed for lower- $N_{ss}$  capability, failures became epidemic. This led to a call for "lower-suction specific speed pumps," or, more accurately, pumps designed for lower- $N_{ss}$  capability; specifically 11,000 ( $\Omega_{ss} = 4$ ) or less<sup>72</sup>.

The  $NPSH$ -effect does come into play—as with  $K_3$  in the previous general method — through the factor  $K_M$  in Figure 39a. In this case, the term  $NPSH_R$  means  $NPSH_{3\%}$ . Here again, it is the ratio  $R = NPSH_A/NPSH_R$  that is the determining factor because it is a measure of the cavitation activity that is invariably present in the first stage of a pump, and

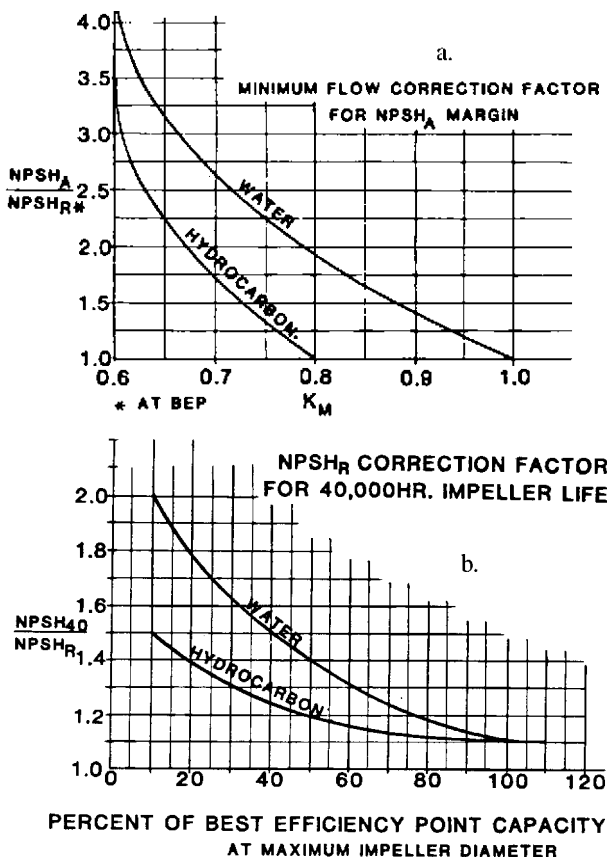


FIGURE 39  $NPSH$ -effects on: a) MCSF and b) impeller life<sup>71</sup>

therefore in all single-stage pumps. The lower the value of  $R$ , the more violent the pressure pulsations accompanying the recirculating fluid and the consequent vibration. The situation is mitigated considerably at greater  $R$ , and  $K_M$  operates through Eq. 68 to decrease the  $MCSF$ . Of course, if  $R$  were great enough—often 5 or more— $NPSH_A$  would exceed  $NPSH_i$  (as discussed in Section 2.3.1) and there would then finally really be no cavitation in the pump. (That high a value of  $NPSHA$  is rare; for, if it were supplied, there would hardly be a need for a pump in the first place.)

Figure 39a also brings in the effect of the liquid being pumped. When room temperature water boils (cavitates), the mass boiled off by the local drop below the vapor pressure makes considerably more cavity or bubble volume than some other liquids, namely hydrocarbons and hot water<sup>17</sup>. (See Section 2.3.1.) The table refers to room temperature or cold water.

By way of illustration, computing the minimum flow of the end-suction volute pump of the *Design Example* begins with Curve B in Figure 38 (for pumps with 6-inch discharge and larger and for 1800 rpm and lower as stated on the figure). [This pump has a discharge port of about 9 inches (229 mm) as would be the case if the velocity in this port were half of the throat velocity  $V_T$  in Part A of Table 11, as suggested previously in the paragraphs on *Volutes* under *Designing the Collector*.]  $N_{ss}$  for this pump was chosen as 12,300 ( $\Omega_{ss} = 4.5$ ), which yields 41.5% for  $K_7$ . If it were decided to provide this cold-water pump with 16.4 ft (5 m) of  $NPSH_A$ ,  $R$  would be 1.17, and the figure yields 0.97 for  $K_M$ . [ $NPSH_{3\%} = 14$  ft. (4.27 m) for this pump, as seen in Table 6.] Thus, from Eq. 68, this pump has an  $MCSF$  of  $0.415 \times 0.97$  or 40% of  $Q_{BEP}$ . Had it been designed for  $N_{ss} = 11,000$  ( $\Omega_{ss} = 4.025$ ), and if  $R$  still were 1.17, the  $NPSH_A$  would have been 19 ft (5.8 m) and  $MCSF$  would have been  $0.36 \times 0.97$  or 35% of  $Q_{BEP}$ . Moreover, if it were pumping hydrocarbons at this same  $NPSH_A$ ,  $MCSF$  would have been even lower, namely  $0.36 \times 0.78$  or 28% of  $Q_{BEP}$ . It would appear, though, that for many applications, the pump as designed (at  $\Omega_{ss} = 4.5$ ) has a low enough energy level to allow for an adequate range of flow-rate capability, and that therefore, the value  $N_{ss} = 12,300$  is in this case not excessive.

**Cavitation Considerations** Having alluded to and treated the subject of cavitation a number of times in this section, we should expand on the role that this ever-present phenomenon plays in the operation and durability of centrifugal pumps, particularly those having a high energy level. The manifestations of cavitation that are encountered and become issues for the operability and life of a pump are a) cavitation accompanying backflow from the impeller eye, b) cavitation-generated instabilities and pressure pulsations, and c) erosion, which involves the prediction of the  $NPSH_R$ -versus-flow rate characteristic curve to maintain life and, conversely (d) the prediction of life for a given  $NPSH_A$ . The range of  $NPSH$  over which cavitation occurs within a pump extends from the point where pump head or pressure rise undergoes an identifiable drop—usually 3% for repeatable results for the  $NPSH$ -value involved—namely the “performance- $NPSH$ ” or  $NPSH_{3\%}$ —upwards. As  $NPSH$  increases from this point, there is an extensive range over which no observable performance loss is detected, yet erosive damage is progressing at a sometimes excessive rate. Finally, at the upper end of the range, all two-phase activity ceases—all bubbles and cavities are suppressed—namely, at the inception- $NPSH$  value or  $NPSH_i$ . As stated previously,  $NPSH$  has been observed to be typically about five times  $NPSH_{3\%}$ . This is clearly described in Section 2.3.1, in which the different  $NPSH$ -limits are distinguished. The following cavitation considerations pertain to this range.

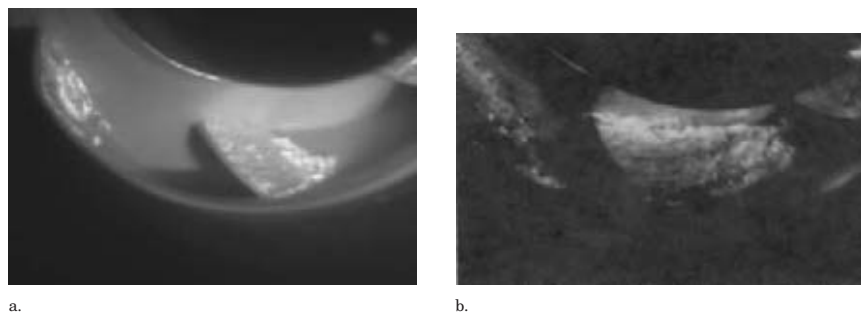
a) *Cavitation and backflow.* The minimum flow limits imposed by the  $R$ -value or  $NPSH$ -effect arise partly because a lower flow rate at a low  $NPSH$ —although it may be in excess of  $NPSH_{3\%}$ —involves a strong interaction between suction recirculation and cavitation that can be intense, especially for inducers and large-eye (large  $D_1/D_2$ ) impellers. At flow rates  $Q \ll Q_{SR}$ , there exists upstream of the impeller an annulus of back-flowing fluid that emerges from the impeller. Drawing the velocity diagram at the impeller leading edge at the shroud for the case of reversed flow reveals that the absolute velocity component  $V_i$  is mostly circumferential and ii) is greater than the impeller tip speed  $U_{i,1}$  or  $U_c$ . Thus the fluid leaving the impeller hugs the outer wall of the approach passage. If this passage is an axial pipe supplying an end-suction impeller or inducer, the pressure along the centerline can be below the vapor pressure, thus creating a vapor core that extends many

diameters upstream, as was shown in a photograph that is part of an article by Yedidiah<sup>73</sup>. Obviously the energetic backflow has to be balanced by an equivalent inflow that enters the impeller from the interior of the pipe and therefore along the hub streamline of the impeller. Vapor from the core is drawn in also and tends to fill the impeller and vapor-lock it. At this point, the pressure to drive the highly spinning liquid upstream is non-existent and the backflow ceases. The vapor core disappears and the impeller once more begins ingesting liquid, the process just described repeating itself at a very low frequency (as low as 1 to 6 Hz) and called cavitation surge<sup>74</sup>. It has been found possible to passively divert the backflowing liquid outward from the inlet passage at the impeller or inducer eye into a series of vaned passages surrounding the inlet pipe, the vanes deswirling the backflowing liquid and returning it to a point or annular port upstream. Properly designed, this “backflow recirculator” has completely eliminated all cavitation instabilities in inducers—over the full range of flow rate from shut-off to run-out. It was shown to work for some high- $N_{ss}$  impellers to which it was applied<sup>74</sup>. Cavitation surge, however, is rarely seen in low- $N_{ss}$  impellers and is usually completely avoided by running the pump at flow rates greater than minimum flow  $Q_{\min}$  as established by one of the previous methods or by test.

*b) Cavitation-related instabilities and pressure pulsations.* At flow rates greater than  $Q_{\min}$ , cavitation can cause or intensify pressure pulsations. Such instabilities are connected with the variety of cavity and bubble configurations that can exist over the range of flow rates and  $NPSH$ - or  $R$ -values. The nature and extent of cavitating flow within a pump has been studied extensively by visual observation. Figures 40 and 41 are laboratory photographs<sup>61</sup> of a sector of a boiler feed pump impeller eye, in which the suction sides of some of the blades are visible. These were taken with the aid of a bright flash that lasted for 1  $\mu s$ . They can also be found in Ref. 24 of Section 2.3.1. Figure 40a shows the sheet cavity that exists at BEP flow rate and at an  $R$ -value of 2. Also observed at BEP—but at  $R = 1$  (that is,  $NPSH = NPSH_{3\%}$ )—is the thick, extensive cavity of Figure 40b. This cavity extends from the blade leading edge to the throat formed by the leading edge of the following blade, and this same pattern exists on every blade. Most observers note that when this suction-side cavity reaches the next throat, the pressure rise or liquid head starts breaking down—which is what is recorded at this “3-percent- $NPSH$ ” point. Instabilities tend to be at a minimum at both of these relatively steady-flow conditions.

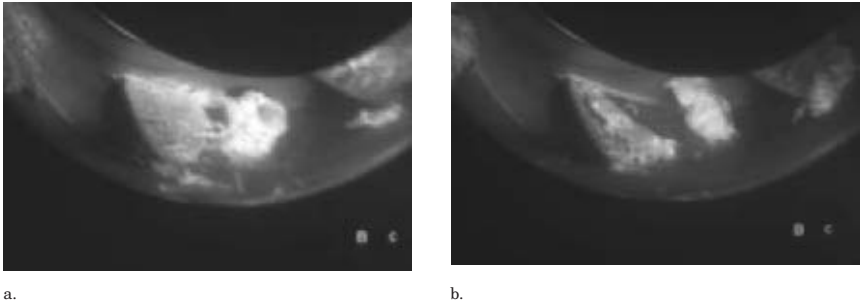
Figure 41, on the other hand, displays highly unsteady cavity flows. Both photographs (A and B) were taken at the same half-flow condition at different instants—for  $R = 2$ . A similar sequence of three photographs at this condition appears in Section 9.5, and none of the three possesses a cavity pattern that resembles either of the others. The position of the somewhat smaller cloud in Figure 41b that has broken off the main cavity appears to be traveling toward the pressure-side (out of sight) of the next blade. Pressure-side cavitation erosion would be the result, and this accords with the findings in Section 2.3.2.

Pressure pulsations are associated with unsteady cavitation patterns, and plots of the amplitude and frequency of suction pressure pulsations show increasing frequency as  $R$  is



**FIGURE 40** Cavities on impeller blades at BEP flow rate: a)  $NPSH = 2 \times NPSH_{3\%}$ ; b)  $NPSH = NPSH_{3\%}$ . (Source: Flowserve Corporation)<sup>61</sup>





**FIGURE 41A and B** Cavities on impeller blades at half the BEP flow rate:  $NPSH = 2 \times NPSH_{3\%}$ . (Source: Flowsolve Corporation)<sup>61</sup>

increased—as would be expected as bubble size is reduced. The amplitude peaks at  $R$  greater than 1—usually closer to 2. Elimination of these instabilities is best done by avoiding cavitation. This can be done by increasing  $NPSHA$  and optimizing the blade shape for minimum cavity activity<sup>75</sup>. To avoid the excessive pump and system oscillations that can occur, some users specify that a cavitation-flow visualization test be conducted and require that minimal or no cavities shall be observed.

*c) Erosion due to cavitation and the prediction of the Life-NPSH.* In the majority of cases cavitation is unavoidable, and the issue becomes the life of component (usually the impeller) in resistance to attack by collapsing bubbles and larger cavities as they are swept out of the low-pressure regions near the blade leading edges. The pressure created at the point and instant of collapse is immense. Photographs of the erosive damage resulting from this activity can be found in Sections 2.3.1 and 9.5. The surface failure mechanism is one of fatigue due to repeated collapse of bubbles adjacent to the blade. This happens at a large number of closely spaced sites, the resulting erosion having a strongly pitted texture. The rate of erosive depth penetration into the surface of a venturi subject to bubble collapse was found by Knapp<sup>76</sup> to increase as the sixth power of velocity  $V$  at a constant cavitation number  $k = 2(p_1 - p_v)/\rho V^2$ . In other words, the erosion rate increased as the third power of  $(p_1 - p_v)$  or  $NPSH$  at the inlet of the venturi, which means that the collapse pressure rises with  $NPSH$ , as is known from the Rayleigh bubble collapse theory. The velocity  $V$  in Knapp's venturi corresponds in a pump to the maximum relative velocity  $W$  at inlet—which is conveniently represented by the impeller inlet tip speed  $U_{t,1}$  as a criterion for damage rate—and  $\tau$  corresponds to the cavitation number  $k$ . For a given impeller at constant  $Q/N$  and a constant value of  $\tau$ , (or at a constant available suction specific speed,) the higher  $U_{t,1}$  is, the greater the  $NPSH$  and the greater the damage rate. Also, as mentioned earlier, a higher value of  $U_{t,1}$  implies a correspondingly greater  $U_2$  and, therefore, greater pump pressure rise or head. Therefore, high-head pumps are more likely to suffer from cavitation erosion, making cavitation a “high-energy” pump phenomenon. High pressure-rise has already been shown to be a feature of high energy pumps through the definition of energy level in terms of classical stress loading (Figure 32).

Facing the reality of high-energy pump destruction due to cavitation erosion, Vlamming redefined the term “ $NPSHR$ ” to mean  $NPSH_{40,000 \text{ hrs}}$ ; that is, the  $NPSH$  needed to limit the damage sufficiently so as to ensure an impeller life of 40,000 hours. He developed an empirical method for predicting the curve of this “damage- $NPSH$ ” versus flow rate for conventionally-designed impellers<sup>77</sup>. This method is defined in Table 17 and includes the inlet tip speed effect on the erosion rate. A value of the vaporization factor  $C_b$  that is less than unity applies to hot water and to other liquids such as hydrocarbons, which generate far less vapor volume when they cavitate than does cold water. (See the earlier discussion under  $NPSH$  Effects in the subsection on *Specific Speed and Optimum Geometry*.) (Rather than depend on theory for the API process pumps men-

**TABLE 17** *NPSH* required for 40,000 hours life<sup>77</sup>

$$NPSH_R = NPSH_{SE} + f \left( \frac{Q}{Q_{BEP}}, \frac{Q_{BEP}}{Q_{SE}}, NPSH_{SE} \right)$$

where

$$NPSH_{SE} = C_a \cdot C_b \cdot C_c \cdot \left[ (k_1 + k_2) \phi_e^2 + k_2 \right] \cdot \frac{U_e^2}{2g}$$

and  $C_a$  = Specific Speed Effect (= 1 for  $N_s \geq 1000$ ) ( $\Omega_s \geq 0.366$ )

$C_b$  = Vaporization Effect [= 1 for cold water; 0.74 for 350°F (177°C) water]

$C_c$  = Material Effect (= 1 for 12 Cr. Stainless Steels)

$k_1$  = 1.2

$$k_2 = 0.2334 + \left\{ \frac{[U_e \text{ (ft/sec)/400}]^4}{[U_e \text{ (m/s)/128.3}]^4} \right\} = \begin{cases} \text{inlet tip} \\ \text{speed effect} \end{cases}$$

$$f = \begin{cases} \left[ 887 \left( \frac{Q_{SE}}{Q_{BEP}} - \frac{Q}{Q_{BEP}} \right) + 893 \left( \frac{Q_{SE}}{Q_{BEP}} - \frac{Q}{Q_{BEP}} \right)^2 \right] \cdot X \left\{ \frac{Q}{Q_{SE}} \leq 1 \right. \\ \left. \left[ 2820 \left( \frac{Q}{Q_{BEP}} - \frac{Q_{SE}}{Q_{BEP}} \right) + 6610 \left( \frac{Q}{Q_{BEP}} - \frac{Q_{SE}}{Q_{BEP}} \right)^2 \right] \cdot X \left\{ \frac{Q}{Q_{SE}} \geq 1 \right. \right. \end{cases}$$

$$\text{and } X = (S^{1.105} - S)/1000 \quad \text{where } S = \begin{cases} NPSH_{SE} \text{ (ft)} \\ 3.2808 \times NPSH_{SE} \text{ (m)} \end{cases}$$

tioned earlier in connection with their minimum flow data, Heald and Palgrave quantified  $NPSH_{40,000 \text{ hrs}}$  in Figure 39b<sup>71</sup>.)

Applied to the high-energy multistage pump suction stage of Figure 33 and Table 14, Vlaming's method yields the  $NPSH_R$ -values shown in Table 18 under the heading  $\phi_e = 0.3$ . These are plotted as the  $NPSH_{40,000 \text{ hrs}}$ -curve on Figure 37. The blades of the pump are assumed to be set for zero incidence of the incoming flow to their camber lines at the BEP —called “shockless entry” and denoted by “SE.” (Many designers make  $Q_{SE}$  somewhat larger than  $Q_{BEP}$  to achieve lower  $NPSHR$  at  $Q > Q_{BEP}$ .) The column to the right in the table contains the results for the same method applied to the more common case for high-energy pump suction stages, namely  $\phi_e = 0.25$  (and lower). For the same shaft diameter, flow rate and speed,  $\phi_e = 0.25$  yields a larger eye diameter through Eq. 49; namely, 13.92 in. (353.6 mm) versus 13.37 in. (339.6 mm) for the  $\phi_e = 0.3$  case as shown in Figure 33. Moreover, that figure shows the inlet tip speed  $U_{t,1}$  ( $U_e$ ) to be 274 ft/sec (84 m/s), whereas for the larger-eye case the value is computed to be 286 ft/sec (87 m/s). As Table 18 reveals, this larger-eye impeller has a lower value of  $NPSH_{3\%}$  (as computed from the correlations of Table 1), which is the reason for sizing large eyes. But Vlaming's method indicates that the smaller eye requires less “damage- $NPSH$ ” ( $R = 1.69$ ) than does the larger eye ( $R = 2.06$ ), even though the latter requires less “performance- $NPSH$ ” or  $NPSH_{3\%}$ . So, from both a minimum-flow and a cavitation damage standpoint, the advantage of a smaller eye for high energy levels is evident.

*d) Prediction of life for a given  $NPSH_A$ .* The inverse of the foregoing problem is how to determine the life under cavitating conditions at a given value of available  $NPSH$ . Gülich found a connection between an observed length  $L_{cav}$  of the cavity trailing off the leading

**TABLE 18** *NPSHR* of high-energy pump suction stages

A) NPSH Required to Maintain Head Rise:  $NPSH_{3\%}$

NPSH <sub>3%</sub> , ft(m) (3% reduction in ΔH)	$\frac{Q}{Q_{BEP}}$	NPSH <sub>3%</sub> , ft(m)	
		$\phi_c=0.3^*$	$\phi_c=0.25$
$k_1 = 1.69$ $k_2 = 0.102$ } [Table (1)] [Empirically Calculated]	[100]	0.2633	0.214
	100	307(94)	271(83)
	150	1150(350)	1150(350)

B) NPSH Required to Limit Cavitation Damage:  $NPSH_{40,000 \text{ hrs}}$

NPSH <sub>40,000 hrs. Life</sub>	$\frac{Q}{Q_{BEP}}$	NPSH <sub>R</sub> , ft(m)	
		$\phi_c=0.3^*$	$\phi_c=0.25$
Vlamings' } Empirical } Method } (for $Q_{SE} = Q_{BEP}$ )	0.25	1081(329)	1174(358)
	0.50	840(256)	910(277)
	0.75	653(199)	705(215)
	0.90	566(173)	610(186)
	1.00	519(158)	559(170)
	[1.00]	$R=1.69$	$R=2.06$
$R = \frac{NPSH_{40,000 \text{ hrs.}}}{NPSH_{3\%}}$	1.10	687(209)	743(226)
	1.25	1058(322)	1148(350)
	1.50	1994(608)	2173(662)

\*Values predicted for sample high-energy pump suction stage:  $\phi_c = 0.3$ ;  $\phi_c \leq 0.25$  widely typical of suction (1<sup>st</sup>) stages.

edge of the blade at BEP (Figure 40a) and the life of an impeller operating at this condition<sup>78</sup>. The resulting procedure is outlined in Table 19, beginning with the definition that the life is the time it takes for the erosion to penetrate through 75% of the blade (or wall) thickness. In the absence of a cavitation-visualizing test,  $L_{cav}$  can be estimated as suggested by the last two formulas in Table 19<sup>75</sup>. Critical to this estimate is the assumed value of the “inception-*NPSH*” or  $\tau_i$ . For conventionally designed impeller blades,  $\tau_i \approx 1$  at the BEP, whereas aerodynamically shaped blades that minimize the local reduction of static pressure have been produced with  $\tau_i < 0.5$  at the BEP<sup>75,79</sup>. The life computations of Table 20 follow from application of the method of Table 19 to the sample suction stage of Figure 33 for  $\tau_i = 1$  and 0.5. Higher values of  $\tau_i$  apply for  $Q \neq Q_{BEP}$ —as might be expected from the shape of Vlamings’  $NPSH_{40,000 \text{ hrs.}}$ -curve in Figure 37 and the fact that the local pressure reduction in the leading-edge region increases with incidence. From this and the results of Table 20, it is evident that improvements to conventional blade-design practice are essential if life is to exceed half a year. Further, this life calculation method is based on the existence of a sheet cavity like that of Figure 40a; and the disordered cavity structures of Figure 41, which happen in the presence of recirculation, are not addressed. Low-flow cavitation damage is generally more severe, and is described in Section 2.3.2.

**TABLE 19** Prediction of life under cavitating conditions**Table 19.** Prediction of Life Under Cavitating Conditions

Life = the minimum of (Life<sub>s,s.</sub>, Life<sub>p,s.</sub>),

where s.s. = suction side of blade;

and p.s. = pressure side of blade.

And where Life = 0.75 × t/MDPR,

where t = blade thickness, mm;

MDPR = mean depth of penetration rate, mm/hour.

$$\text{MDPR} = \left[ C \times (L_{\text{cav}}/10)^n \times (\tau_A - \phi_e^2)^3 \times U_e^6 \times \rho_L^3 \times A \right] / \left[ 8 \times F_{\text{mat}} \times (\text{TS})^2 \right] \text{ mm/h}$$

Where C = 8.28 E-06 (s.s.), 396 E-06 (p.s.); and n = 2.83 (s.s.), 2.6 (p.s.);

$\tau = \text{NPSH} / (U_e^2 / 2g)$ ; dimensionless

$U_e$  is blade inlet tip speed in m/s

$\phi_e = V_{m,1} / U_e$ , where  $V_{m,1}$  = average axial inlet velocity, (typically  $\phi_e = 0.25$ );

$\rho_L = 1000 \times \text{sp. gravity of the liquid}$ ; A = 1 for cold water, 0.705 for 350° F (177° C) water;

$F_{\text{mat}} = 1$  for martensitic: stainless steel, 1.7 for austenitic stainless steel;

TS = tensile strength in Pa [= 860,000,000 (= 125,000 psi) for 13 Cr and  
= 552,000,000 (= 80,000 psi) for 18 Cr, 8 Ni.]

$L_{\text{cav}} \approx (\pi \times D_e / n_b) \times \left\{ 1 - [(\tau_A - \tau_{3\%}) / (\tau_i - \tau_{3\%})]^{1/3} \right\}$  if  $\tau_A < \tau_i$  (mm)

$L_{\text{cav}} = 0$  if  $\tau_A > \tau_i$

Moreover, corrosion can play a role in cavitation-related erosive activity, an effect that was also addressed in Gülich's work.<sup>78</sup> Nevertheless, the ability to compute erosive behavior—even at the BEP—allows one to evaluate design improvements and provides a good idea of the life that can be expected under normal operating conditions.

Obviously, if the available *NPSH* is greater than the inception-*NPSH* (that is,  $\tau_A > \tau_i$ ), there is no bubble activity of any kind, and at  $Q_{\text{BEP}}$  the cavity length  $L_{\text{cav}} = 0$ . An illustration of what can be achieved in this regard is presented in Figures 24 and 25 of Section 9.5, which are the “before” and “after” photographs of the model impeller blades for the first stage of a 24,000 hp (18 MW) pipeline pump. Quasi-three dimensional analysis of the blade pressure loading led to changes in shape that eliminated the cavities<sup>53,75</sup>. This complete absence of cavitation is becoming the desired objective for the design and application of new and upgraded multistage high-energy pump suction stages. This approach eliminates both the erratic mechanical behavior that occurs in response to unsteady cavity patterns and the erosion due to bubble collapse; thereby substantially increasing the life and reliability of such machines<sup>80</sup>.

**TABLE 20** Life of high-energy pump suction stage

A) Pump data for computing life [at the B.E.P. of 20,000 gpm (1,262 m<sup>3</sup>/s)]

- NPSH<sub>3%</sub> = 307 ft ( 94 m ) ; thus,  $\tau_{3\%} = 0.263$
- NPSHA = 519 ft (158 m) ; thus,  $\tau_A = 0.444$
- $t_{blade} = 0.42$  in (10.7 m) ; thus,  $F_{mat} = 1$  (13 Cr martensitic stainless steel)
- Suction-side cavitation in 350°F (177°C) boiler feedwater, for which  $A=0.705$
- Inlet flow coefficient  $\phi_e = 0.3$ ;  $U_e = 274.2$  ft/sec (83.57 m/s);  $U_e^2/2g = 1168$ ft (356 m)

B) Results for inception occurring at  $NPSH_i =$  blade inlet tip speed head and half that  $NPSH_i$ .

<p>a) <math>\tau_i = 1.0 = 3.8 \times \tau_{3\%}</math>  <math>NPSH_i = 1168</math> ft (356 m)  <math>L_{cav} = 57.0</math> mm  MDPR = 0.0014482 mm/hour  Life = 5,541 hours = 7.6 months</p>	<p>b) <math>\tau_i = 0.5 = 1.9 \times \tau_{3\%}</math>  <math>NPSH_i = 584</math> ft (178 m)  13.1 mm  0.000022257 mm/hour  360,000 hours = 41 years</p>
---	---

C) Sample Life Calculation  $\left\{ \begin{array}{l} \text{High Energy} \\ \text{Pump Suction Stage} \end{array} \right.$

$$L_{cav} = 25.4 \times \frac{\pi \times 13.37}{7} \times \left[ 1 - \left( \frac{0.444 - 0.263}{1 - 0.263} \right)^{1/3} \right] = \underline{57.0 \text{ mm}}$$

$$MDPR = \frac{8.28 \times 10^{-6} \times \left( \frac{57}{10} \right)^{2.83} \times \left( 0.444 - 0.3^2 \right) \times (83.57)^6 \times (890)^3 \times 0.705}{8 \times 1 \times \left( 860 \times 10^6 \right)^2}$$

$$= 0.0014482 \text{ mm / hour} \left( \times 8760 \frac{\text{hr}}{\text{year}} = 12.7 \text{ mm/yr} \right)$$

$$\begin{aligned} \text{Life} &= 0.75 \times 10.7 / 0.0014482 &&= \underline{5,541 \text{ hours}} \\ &&&= \underline{7.6 \text{ months}} \end{aligned}$$

## REFERENCES

1. Jennings, G. P., and Meade, L. P. "Determination of Pump Efficiencies from Fluid Temperature Rise." Presented at the 7th Annual Spring Pipeline Conference, Houston, Texas, May 14, 1956, under the auspices of the American Petroleum Institute's *Division of Transportation*. Published in the Division's Vol. 36 [5] 1956.
2. Cooper, P., and Reshotko, E. "Turbulent Flow Between a Rotating Disk and a Parallel Wall." *AIAA Journal*. Volume 13, No. 5, May 1975, pp. 573-578.

3. Sabersky, R., and Acosta, A. J. *Fluid Flow*, Macmillan, p. 76 (1966).
4. Stepanoff, A. J. *Centrifugal and Axial Flow Pumps*. 2nd ed. Krieger Publishing, Malabar, FL, 1957.
5. Iversen, H. W. "Performance of the Periphery Pump." *Transactions of the ASME*. Vol. 77, Jan. 1955, pp. 15–28.
6. Anderson, H. H. "Prediction of Head, Quantity and Efficiency in Pumps—The Area Ratio Principle." *Performance Prediction of Centrifugal Pumps and Compressors*. ASME, 1980, pp. 201–211.
7. American National Standard for Centrifugal Pumps for Design and Application, ANSI/HI 1.3-2000, Section 1.3.4.1.11-14, Hydraulic Institute, Parsippany, NJ, www.pumps.org.
8. Cooper, P. "Analysis of Single- and Two-Phase Flows in Turbopump Inducers." *Transactions of the ASME, Journal of Engineering for Power*. Vol. 89, Series A, Oct. 1967, pp. 577–588.
9. Turpin, J. L., Lea, J. F., and Bearden J. L. "Gas-Liquid Flow Through Centrifugal Pumps—Correlation of Data." *Proceedings of the Third International Pump Symposium*, Texas A&M University, 1986, pp. 13–20.
10. Runstadler, P. W., Jr., and Dolan, F. X. "Two-Phase Flow, Pump Data for a Scale Model NSSS Pump." *Polyphase Flow in Turbomachinery*, ASME, 1978, pp. 65–77.
11. Cooper, P., and others. "Tutorial on Multiphase Gas-Liquid Pumping." *Proceedings of the Thirteenth International Pump Users Symposium*, Texas A&M University, Mar. 1996, pp. 159–174.
12. Kasztejna, P. J., and Cooper, P. "Hydraulic Development of Centrifugal Pumps for Coal Slurry Service." *Proceedings of the Eighth International Symposium on Coal Slurry Fuels Preparation and Utilization*. U.S. Dept. of Energy, May 1986.
13. Gongwer, C. A. *Transactions of the ASME*. Vol. 63, Jan. 1941, pp. 29–40.
14. Stripling, L. B., and Acosta, A. J. "Cavitation in Turbopumps." Parts 1 and 2, *Transactions of the ASME*. Series D, 1961.
15. Lazarkiewicz, S., and Troskolanski, A. T. *Impeller Pumps*. Pergamon Press.
16. Katsanis, T., and McNally, W. D. "Revised Fortran Program for Calculating Velocities and Streamlines on the Hub-Shroud Midchannel Stream Surface of an Axial-, Radial-, or Mixed-Flow Turbomachine or Annular Duct." I, User's Manual, NASA TN D-8430, and II, Programmer's Manual, NASA TN D-8431, 1977.
17. Cooper, P. "Application of Pressure and Velocity Criteria to the Design of a Centrifugal-Pump Impeller and Inlet." *Transactions of the ASME*. Series A, Apr. 1964, pp. 181–190.
18. Busemann, A. "Das Förderhohenverhältniss Radialer Kreiselpumpen mit Logarithmischspiraligen Schaufeln." *Zeitschrift für Angewandte Mathematik und Mechanik*. Vol. 8, Oct. 1928, pp. 372–384.
19. Wiesner, F. J. "A Review of Slip Factors for Centrifugal Pumps." *Transactions of the ASME*. Series A, Oct. 1967, pp. 558–572.
20. Pfeleiderer, C. *Die Kreiselpumpen für Flüssigkeiten und Gase*. 5te Auflage, Springer-Verlag, 1961.
21. Dicmas, J. L. *Vertical Turbine, Mixed Flow, and Propeller Pumps*. McGraw-Hill, 1987.
22. Stanitz, J. D., and Prian, V. D. "A Rapid Approximate Method for Determining the Velocity Distribution on Impeller Blades of Centrifugal Compressors." TN 2421, NACA, July 1951.
23. Lieblein, S. "Experimental Flow in Two-Dimensional Cascades." Chap. VI in *Aerodynamic Design of Axial-Flow Compressors*. SP-36, NASA, 1965, pp. 202–205.
24. Guinzburg, A., and others. "Emerging Sewage Pump Design Requirements." *1997 ASME Fluids Engineering Division Summer Meeting*. Paper FEDSM97-3325, June 1997.

25. Worster, R. C. "The Flow in Volute and Its Effect on Centrifugal Pump Performance." *Proceedings of the Institution of Mechanical Engineers*. Vol. 177, No. 31, 1963.
26. Lorett, J. A., and Gopalakrishnan, S. "Interaction Between Impeller and Volute of Pumps at Off-Design Conditions." *Transactions of the ASME, Journal of Fluids Engineering*. Vol. 108, Mar. 1986, pp. 12–18.
27. Miller, D. S. *Internal Flow Systems*, BHRA Fluid Engineering, 1978.
28. Japikse, D. "A Critical Evaluation of Stall Concepts for Centrifugal Compressors and Pumps—Studies in Component Performance, Part 7." In *Stability, Stall and Surge in Compressors and Pumps*. FED—Vol. 19, ASME, Dec. 1984, pp. 1–10.
29. Kovats, A. "Diffusers of Multistage Centrifugal Pumps." In *Return Passages of Multi-Stage Turbomachinery*. FED—Vol. 3, ASME, June 1983, pp. 61–66.
30. Reneau, L. R., and others. "Performance of Straight, Two-Dimensional Diffusers." *Transactions of the ASME*. Series D, Vol. 89, 1967, pp. 141–150.
31. Fox, R. W., and Kline, S. J. "Flow Regimes in Curved, Subsonic Diffusers." *Transactions of the ASME*. Series D, Vol. 84, 1962, pp. 303–316.
32. Sagi, C. J., and Johnston, J. P. "The Design and Performance of Two-Dimensional, Curved Diffusers." *Transactions of the ASME*. Series D, Vol. 89, 1967, pp. 715–731.
33. Bolleter, U. "Blade Passage Tones of Centrifugal Pumps." *Vibrations*. Vol. 4, No. 3, Sep. 1988, pp. 8–13.
34. Nykorowytch, P., Ed. *Return Passages of Multi-Stage Turbomachinery*. FED—Vol. 3, ASME, June 1983.
35. Hill, P. G., and Peterson, C. R. *Mechanics and Thermodynamics of Propulsion*. Addison-Wesley, 1965, pp. 238–280.
36. Stepanoff, A. J. "Centrifugal Pump Performance as a Function of Specific Speed." *Transactions of the ASME*. Aug. 1943, pp. 629–647.
37. Weissgerber, C., and Carter, A. F. "Comparison of Hydraulic Performance Predictions and Test Data for a Range of Pumps." *Performance Prediction of Centrifugal Pumps and Compressors*. ASME, Mar. 1980, pp. 219–226.
38. Streeter, V. L., ed. *Handbook of Fluid Dynamics*. McGraw-Hill, 1961, p. 3–23.
39. Wood, G. M., Welna H., and Lamers, R. P. "Tip-Clearance Effects in Centrifugal Pumps." Paper No. 64-WA/FE-17, ASME, Nov. 1964.
40. Stepanoff, A. J. "Pumping Solid-Liquid Mixtures." Paper No. 63-WA-102, ASME, Nov. 1963.
41. Katsanis, T. "Quasi-Three-Dimensional Full Analysis in Turbomachines: A Tool for Blade Design." In *Numerical Simulations in Turbomachinery*, FED—Vol. 120, ASME, 1991, pp. 57–64.
42. Katsanis, T. "Fortran Program for Calculating Transonic Velocities on a Blade-to-Blade Stream Surface of a Turbomachine." NASA TN D-5427, 1969.
43. Spring, H. "Affordable Quasi-Three-Dimensional Inverse Design Method for Pump Impellers." *Proceedings of the Ninth International Pump Users Symposium*, Texas A&M University, College Station Texas, Mar. 1992, pp. 97–110.
44. Daily, J. W., and Nece, R. E. "Chamber Dimension Effects on Induced Flow and Frictional Resistance of Enclosed Rotating Disks." *Transactions of the ASME*, Series D, Vol. 82, Mar. 1960, pp. 217–232.
45. Nece, R. E., and Daily, J. W. "Roughness Effects on Frictional Resistance of Enclosed Rotating Disks." *Transactions of the ASME*. Series D, Vol. 82, Sep. 1960, pp. 553–562.
46. Graf, E. "Analysis of Centrifugal Impeller BEP and Recirculating Flows: Comparison of Quasi-3D and Navier-Stokes Solutions." *Pumping Machinery—1993*. FED—Vol. 154, ASME, 1993, pp. 235–245.

47. Gülich, J. F., Favre, J. N., and Denus, K. "An Assessment of Pump Impeller Performance Predictions by 3D-Navier Stokes Calculations." *1997 ASME Fluids Engineering Division Summer Meeting*. Paper FEDSM97-3341, June 1997.
48. Japikse, D., Marscher, W. D., and Furst, R. B. *Centrifugal Pump Design and Performance*. Concepts, ETI, Inc., Wilder, Vermont, 1997.
49. Denus, K., and others. "A Study in Design and CFD Analysis of a Mixed Flow Pump Impeller." *1999 ASME Fluids Engineering Division Summer Meeting*, Paper FEDSM99-6858, July 1999.
50. Jimbo, H. "Investigation of the Interaction of Windage and Leakage Phenomena in a Centrifugal Compressor." Paper No. 56-A-47, ASME, Nov. 1956.
51. Keathly, W. C., Due, H. F., and Comolli, C. R. "A Study of Pressure Prediction Methods for Radial Flow Impellers." Final Report on NASA Contract NAS8-5442, PWA FR-952, Pratt & Whitney Aircraft, W. Palm Beach, Florida, April 1964.
52. Greitzer, E. M. "The Stability of Pumping Systems." *Transactions of the ASME, Journal of Fluids Engineering*, Vol. 103, June, 1981, pp. 193-242.
53. Cooper, P. "Perspective: The New Face of R&D—A Case Study of the Pump Industry." *Transactions of the ASME, Journal of Fluids Engineering*, Vol. 118, Dec. 1996, pp. 654-664.
54. Rothe, P. H., and Runstadler, P. W., Jr. "First-Order Pump Surge Behavior." Paper No. 77-WA/FE-12, ASME, Nov. 1977.
55. Brennen, C., and Acosta, A. J. "The Dynamic Transfer Function for a Cavitating Inducer." *Transactions of the ASME, Journal of Fluids Engineering*. Vol. 98, 1976, pp. 182-191.
56. Schlichting, H. *Boundary Layer Theory*. 4th ed. McGraw-Hill, 1960.
57. "Advanced Class Boiler Feed Pumps." *Proceedings of the Institution of Mechanical Engineers*. Vol. 184, Part 3N, 1970.
58. Gopalakrishnan, S. "Pump Research & Development—Past, Present, and Future: An American Perspective." *1997 ASME Fluids Engineering Division Summer Meeting*. Paper FEDSM97-3387, June 1997.
59. Bolleter, U., Frei, A., and Florjancic, D. "Predicting and Improving the Dynamic Behavior of Multistage High Performance Pumps." *Proceedings of the First International Pump Symposium*. Texas A&M University, College Station Texas, May 1984, pp. 1-8.
60. Iino, T. "Potential Interaction Between a Centrifugal Pump Impeller and a Vaned Diffuser." *Fluid/Structure Interactions in Turbomachinery*. ASME, Nov. 1981, pp. 63-69.
61. Cooper, P. "Hydraulics and Cavitation." *Symposium Proceedings: Power Plant Pumps*. M. L. Adams, ed. EPRI CS-5857, June 1988, pp. 4-109 to 4-149.
62. Sutton, G. P. *Rocket Propulsion Elements*. 6th ed., Wiley, 1992.
63. "Liquid Rocket Engine Centrifugal Flow Turbopumps." Report SP-8109 of the series entitled *NASA Space Vehicle Design Criteria (Chemical Propulsion)*. NASA, 1973.
64. "Turbopump Systems for Liquid Rocket Engines." Report SP-8107 of the series entitled *NASA Space Vehicle Design Criteria (Chemical Propulsion)*. NASA, 1975.
65. Makay, E., Cooper, P., Sloteman, D. P., and Gibson, R. "Investigation of Pressure Pulsations Arising from Impeller/Diffuser Interaction in a Large Centrifugal Pump." *Proceedings: Rotating Machinery Conference and Exposition, ASME*, Vol. 1, 1993.
66. Fischer, K., and Thoma, D. "Investigation of the Flow Conditions in a Centrifugal Pump." *Transactions of the ASME*. Vol. 54, 1932, pp. 143-155.
67. Fraser, W. H. "Recirculation in Centrifugal Pumps." *Materials of Construction of Fluid Machinery and Their Relationship to Design and Performance*. ASME, Nov. 1981, pp. 65-86.



68. Iino, T., Sato, H., and Miyashiro, H. "Hydraulic Axial Thrust in Multistage Centrifugal Pumps." *Transactions of the ASME, Journal of Fluids Engineering*. Vol. 102, Mar. 1980, pp. 64–69.
69. Makay, E., and Barrett, J. A. "Changes in Hydraulic Component Geometries Greatly Increased Power Plant Availability and Reduced Maintenance Cost: Case Histories." *Proceedings of the First International Pump Symposium*. Texas A&M University, College Station Texas, May 1984, pp. 85–97.
70. Gopalakrishnan, S. "A New Method for Computing Minimum Flow." *Proceedings of the Fifth International Pump Users Symposium*. Texas A&M University, College Station Texas, May 1988, pp. 41–47.
71. Heald, C. C., and Palgrave, R. "Backflow Control Improves Pump Performance." *Oil and Gas Journal*. Feb. 25, 1985, pp. 96–105.
72. Hallam, J. L. "Centrifugal Pumps: Which Suction-Specific Speeds Are Acceptable." *Hydrocarbon Processing*, Apr. 1982.
73. Yedidia, S. "Performance Curves: Key to Centrifugal Pump Selection." *Machine Design*. Apr. 10, 1980, pp. 117–122.
74. Sloteman, D. P., Cooper, P., and Dussourd, J. L. "Control of Backflow at the Inlets of Centrifugal Pumps and Inducers." *Proceedings of the First International Pump Symposium*. Texas A&M University, College Station Texas, May 1984, pp. 9–22.
75. Cooper, P., Sloteman, D. P., Graf, E., and Vlaming, D. J. "Elimination of Cavitation-Related Instabilities and Damage in High-Energy Pump Impellers." *Proceedings of the Eighth International Pump Users Symposium*. Texas A&M University, 1991, pp. 3–19.
76. Knapp, R. T. "Recent Investigations of the Mechanics of Cavitation and Cavitation Damage." *Transactions of the ASME*, Oct. 1955, pp. 1045–1054.
77. Vlaming, D. J. "Optimum Impeller Inlet Geometry for Minimum NPSH Requirements for Centrifugal Pumps." *Pumping Machinery—1989*. ASME, July 1989, pp. 25–29.
78. Gülich, J. F. *Guidelines for Prevention of Cavitation in Centrifugal Feedpumps*. EPRI CS-6398, 1989.
79. Sloteman, D. P., Cooper, P., and Graf, E. "Design of High-Energy Pump Impellers to Avoid Cavitation Instabilities and Damage." EPRI Power Plant Pumps Symposium, Tampa FL, June 1991.
80. Sloteman, D. P., and others. "Experimental Evaluation of High-Energy Pump Improvements Including Effects of Upstream Piping." *Proceedings of the Twelfth International Pump Users Symposium*. Texas A&M University, Mar. 1995, pp. 97–110.

---

# SECTION 2.2

---

# CENTRIFUGAL PUMP CONSTRUCTION

---

## 2.2.1 CENTRIFUGAL PUMPS: MAJOR COMPONENTS

IGOR J. KARASSIK  
C. C. HEALD

### **CLASSIFICATION AND NOMENCLATURE**

---

A centrifugal pump consists of a set of rotating vanes enclosed within a housing or casing that is used to impart energy to a fluid through centrifugal force. Thus, stripped of all refinements, a centrifugal pump has two main parts: (1) a rotating element, including an impeller and a shaft, and (2) a stationary element made up of a casing, casing cover, and bearings.

In a centrifugal pump, the liquid is forced by atmospheric or other pressure into a set of rotating vanes. These vanes constitute an impeller that discharges the liquid at its periphery at a higher velocity. This velocity is converted to pressure energy by means of a volute (see Figure 1) or by a set of stationary diffusion vanes (see Figure 2) surrounding the impeller periphery. Pumps with volute casings are generally called *volute pumps*, while those with diffusion vanes are called *diffuser pumps*. Diffuser pumps were once quite commonly called *turbine pumps*, but this term has become more selectively applied to the vertical deep-well centrifugal diffuser pumps usually referred to as *vertical turbine pumps*. Figure 1 shows the path of the liquid passing through an end-suction volute pump operating at rated capacity (the capacity at which best efficiency is obtained).

Impellers are classified according to the major direction of flow in reference to the axis of rotation. Thus, centrifugal pumps may have the following:

- Radial-flow impellers (see Figures 25, 34, 35, 36, and 37)
- Axial-flow impellers (see Figure 29)
- Mixed-flow impellers, which combine radial- and axial-flow principles (see Figures 27 and 28)

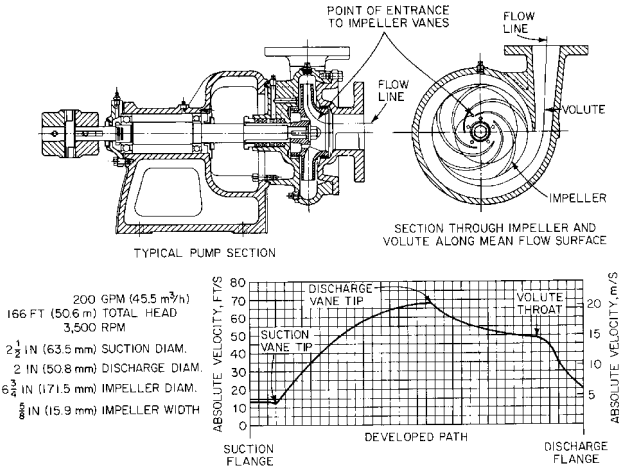


FIGURE 1 A typical single-stage, end-suction volute pump (Flowserve Corporation)

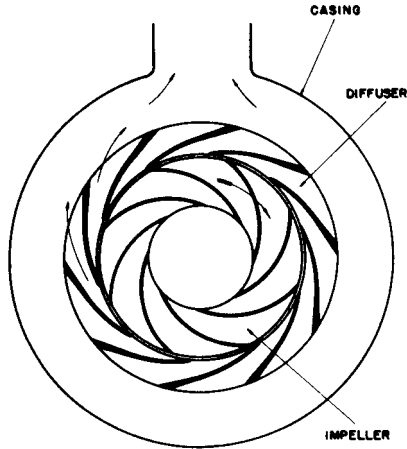


FIGURE 2 A typical diffuser-type pump

Impellers are further classified in one of two categories:

- Single-suction, with a single inlet on one side (see Figures 25, 33, and 37)
- Double-suction, with liquid flowing to the impeller symmetrically from both sides (see Figures 26, 27, and 38)

The mechanical construction of the impellers gives a still further subdivision into

- Enclosed, with shrouds or side walls enclosing the waterways (see Figures 25, 26, and 27)
- Open, with no shrouds (see Figures 29, 33, and 34)
- Semiopen or semi-enclosed (see Figure 36)

A pump in which the head is developed by a single impeller is called a *single-stage pump*. Often the total head to be developed requires the use of two or more impellers operating in a series, each taking its suction from the discharge of the preceding impeller. For this purpose, two or more single-stage pumps can be connected in a series or all the impellers can be incorporated in a single casing. The unit is then called a *multistage pump*.

The mechanical design of the casing provides the added pump classification of *axially split* or *radially split*, and the axis of rotation determines whether the pump is a horizontal or vertical unit.

Horizontal-shaft centrifugal pumps are classified still further according to the location of the suction nozzle:

- End-suction (see Figures 1, 8, 11, and 13)
- Side-suction (see Figures 7 and 10)
- Bottom-suction (see Figure 15)
- Top-suction (see Figure 22)

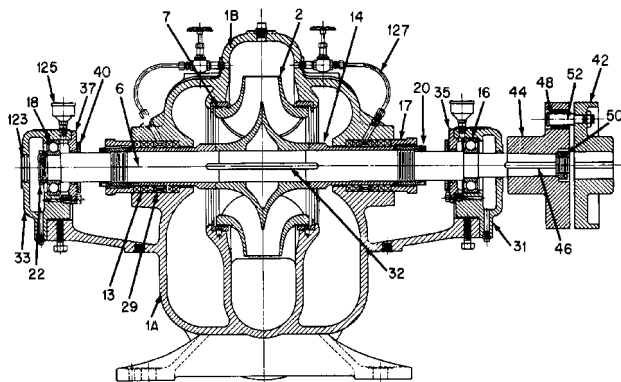
Some pumps operate in air with the liquid coming to and being conducted away from the pumps by piping. Other pumps, most often vertical types, are submerged in their suction supply. Vertical-shaft pumps are therefore called either *dry-pit* or *wet-pit* types. If the wet-pit pumps are axial-flow, mixed-flow, or vertical-turbine types, the liquid is discharged up through the supporting drop or column pipe to a discharge point above or below the supporting floor. These pumps are consequently designated as *aboveground discharge* or *belowground discharge units*.

Figures 3, 4, and 8 show typical constructions of a horizontal double-suction volute pump, the bowl section of a single-stage axial-flow propeller pump, and a vertical dry-pit single-suction volute pump, respectively. The names recommended by the Hydraulic Institute for various pump parts are given in Table 1.

## CASINGS AND DIFFUSERS

**The Volute Casing Pump** This pump (refer to Figure 1) derives its name from the spiral-shaped casing surrounding the impeller. This casing section collects the liquid discharged by the impeller and converts velocity energy to pressure energy.

A centrifugal pump volute increases in area from its initial point until it encompasses the full 360° around the impeller and then flares out to the final discharge opening. The



**FIGURE 3** Horizontal single-stage double-suction volute pump (the numbers refer to parts listed in Table 1) (Flowserve Corporation)

**TABLE 1** Recommended names of centrifugal pump parts

Item no.	Name of part	Item no.	Name of part
1	Gasing	33	Bearing housing (outboard)
1A	Gasing (lower half)	35	Bearing cover (inboard)
1B	Gasing (upper half)	36	Propeller key
2	Impeller	37	Bearing cover (outboard)
4	Propeller	39	Bearing bushing
6	Pump shaft	40	Deflector
7	Gasing ring	42	Coupling (driver half)
8	Impeller ring	44	Coupling (pump half)
9	Suction cover	46	Coupling key
11	Stuffing box cover	48	Coupling bushing
13	Packing	50	Coupling lock nut
14	Shaft sleeve	52	Coupling pin
15	Discharge bowl	59	Handhole cover
16	Bearing (inboard)	68	Shaft collar
17	Gland	72	Thrust collar
18	Bearing (outboard)	78	Bearing spacer
19	Frame	85	Shaft enclosing tube
20	Shaft sleeve nut	89	Seal
22	Bearing lock nut	91	Suction bowl
24	Impeller nut	101	Column pipe
25	Suction head ring	103	Connector bearing
27	Stuffing box cover ring	123	Bearing end cover
29	Lantern ring (seal cage)	125	Grease (oil) cup
31	Bearing housing (inboard)	127	Seal pipe (tubing)
32	Impeller key		

<sup>a</sup>These parts are called out in Figures 3, 4, and 8.

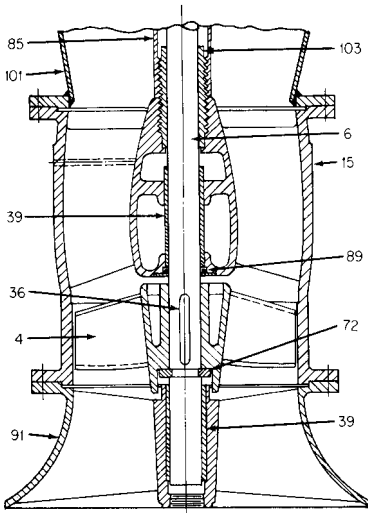
wall dividing the initial section and the discharge nozzle portion of the casing is called the tongue of the volute or the “cutwater.” The diffusion vanes and concentric casing of a diffuser pump fulfill the same function as the volute casing in energy conversion.

In propeller and other pumps in which axial-flow impellers are used, it is not practical to use a volute casing. Instead, the impeller is enclosed in a pipe-like casing. Generally, diffusion vanes are used following the impeller proper, but in certain extremely low-head units these vanes may be omitted.

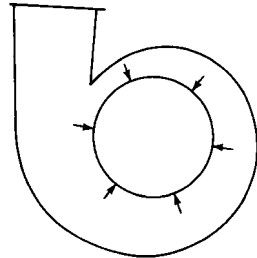
A diffuser is seldom applied to a single-stage, radial-flow pump, except in special instances where volute passages become so small that machined or precision-cast volute or diffuser-like pieces are utilized for precise flow control. Conventional diffusers are often applied to multistage pump designs in conjunction with guide vanes to direct the flow efficiently from one impeller (stage) to another in a minimum radial and axial space. Diffuser vanes are used as the primary construction method for vertical turbine pumps and single-stage, low-head propeller pumps (see Figure 4).

**Radial Thrust** In a *single-volute pump casing* design (see Figure 5), uniform or near uniform pressures act on the impeller when the pump operates at design capacity (which coincides with the best efficiency). At other capacities, the pressures around the impeller are not uniform (see Figure 6) and there is a resultant radial reaction ( $F$ ). A detailed discussion of the radial thrust and of its magnitude is presented in Subsection 2.3.1. Note that the unbalanced radial thrust increases as capacity decreases from that at the design flow.

For any percentage of capacity, this radial reaction is a function of total head and of the width and diameter of the impeller. Thus, a high-head pump with a large impeller diameter will have a much greater radial reaction force at partial capacities than a low-head



**FIGURE 4** Vertical wet-pit diffuser pump bowl (the number refers to parts listed in Table 1) (Flowserve Corporation)



**FIGURE 5** Uniform casing pressures exist at design capacity, resulting in zero radial reaction.

pump with a small impeller diameter. A zero radial reaction is not often realized; the minimum reaction occurs at design capacity.

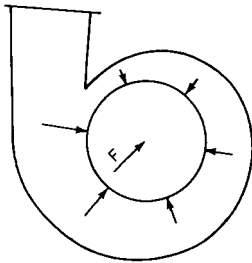
Although the same tendency for unbalance exists in the diffuser-type pump, the reaction is limited to a small arc repeated all around the impeller. As a result, the individual reactions cancel each other out as long as flow is constantly removed from around the periphery of the diffuser discharge. If flow is not removed uniformly around its periphery, a pressure imbalance may occur around the diffuser discharge that will be transmitted back through the diffuser to the impeller, resulting in a radial reaction on the shaft and bearing system.

In a centrifugal pump design, shaft diameter as well as bearing size can be affected by the allowable deflection as determined by the shaft span, impeller weight, radial reaction forces, and torque to be transmitted.

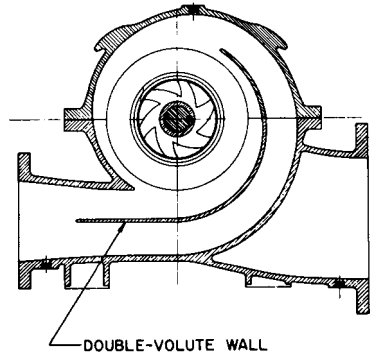
Formerly, standard designs compensated for radial reaction forces encountered at capacities in excess of 50 percent of the design capacity for the maximum-diameter impeller of the pump. For sustained operations at lower capacities, the pump manufacturer, if properly advised, would supply a heavier shaft, usually at a much higher cost. Sustained operations at extremely low flows without the manufacturer being informed at the time of purchase are a much more common practice today. This can result in broken shafts, especially older designs, on high-head units.

Because of the increasing application of pumps that must operate at reduced capacities, it has become desirable to design standard units to accommodate such conditions. One solution is to use heavier shafts and bearings. Except for low-head pumps in which only a small additional load is involved, this solution is not economical. The only practical answer is a casing design that develops a much smaller radial reaction force at partial capacities. One of these is the *double-volute* casing design, also called the *twin-volute* or *dual-volute* design.

The application of the double-volute design principle to neutralize radial reaction forces at reduced capacity is illustrated in Figure 7. Basically, this design consists of two 180° volutes, and a passage external to the second joins the two into a common discharge. Although a pressure unbalance exists at partial capacity through each 180° arc, the two



**FIGURE 6** At reduced capacities, uniform pressures do not exist in a single-volute casing, resulting in a radial reaction  $F_r$ .



**FIGURE 7** Transverse view of a double-volute casing pump.

forces are approximately equal and opposite. Thus, little if any radial force acts on the shaft and bearings. Subsection 2.3.1 also covers this topic.

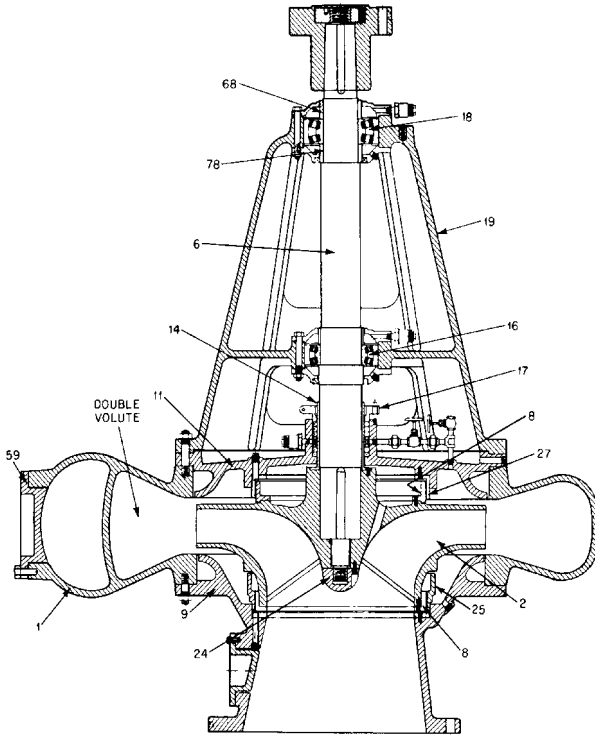
The double-volute design has many hidden advantages. For example, in large-capacity medium- and high-head single-stage vertical pumps, the rib forming the second volute that separates it from the discharge waterway of the first volute strengthens the casing (see Figure 8).

The individual stages of a multistage pump can be made double volute, as illustrated in Figure 9. The kinetic energy of the pumped liquid discharged from the impeller must be transformed into pressure energy and then must be turned  $180^\circ$  to enter the impeller of the next stage. The double volute therefore also acts as a return channel. The back view in Figure 9 shows this as well as the guide vanes used to straighten the flow into the next stage. An alternative to the volute design for multistage pumps is the diffuser and its return vanes that channel the flow from the discharge of the diffuser vanes back into the impeller of the next stage.

**Solid and Split Casings** *Solid casing* implies a design in which the discharge waterways leading to the discharge nozzle are all contained in one casting or fabricated piece. The casing must have one side open so that the impeller can be introduced into it. Because the sidewalls surrounding the impeller are actually part of the casing, a solid casing, strictly speaking, cannot be used, and designs normally called solid casing are really radially split (refer to Figure 1 and see Figures 11, 12, and 13).

A *split casing* is made of two or more parts fastened together. The term *horizontally split* had regularly been used to describe pumps with a casing divided by a horizontal plane through the shaft centerline or axis (see Figure 10). The term *axially split* is now preferred. Because both the suction and discharge nozzles are usually in the same half of the casing, the other half may be removed for inspection of the interior without disturbing the bearings or the piping. Like its counterpart horizontally split, the term *vertically split* is poor terminology. It refers to a casing split in a plane perpendicular to the axis of rotation. The term *radially split* is now preferred.

**End-Suction Pumps** Most end-suction, single-stage pumps are made of one-piece solid casings. At least one side of the casing must be open so that the impeller can be assembled in the pump. Thus, a cover is required for that side. If the cover is on the suction side, it becomes the casing sidewall and contains the suction opening (refer to Figure 1). This is called the *suction cover* or *casing suction head*. Other designs are made with casing covers (see Figure 12) and still others have both casing suction covers and casing covers (refer to Figure 8 and see Figure 13).



**FIGURE 8** The sectional view of a vertical-shaft, end-suction pump with a double-volute casing (the numbers refer to parts listed in Table 1) (Flowserve Corporation)



**FIGURE 9** The double volute of a multistage pump, front view (left) and back view (right) (Flowserve Corporation)

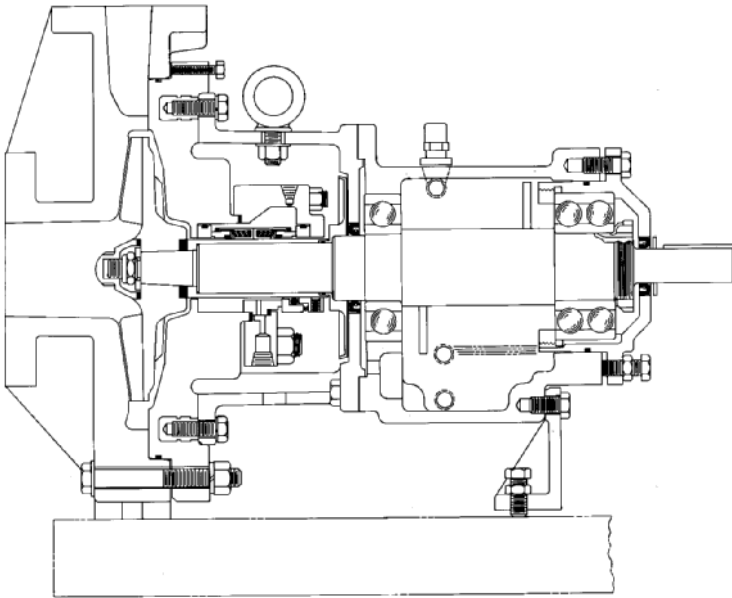
For general service, the end-suction, single-stage pump design is extensively used for small pumps with a 4- or 6-in (102 or 152 mm) discharge size for both motor-mounted and coupled types. In these pumps, the small size makes it feasible to cast the volute and one side integrally. Whether or not the seal chamber side or the suction side is made integrally with the casing is usually determined by the most economical pump design.

For larger pumps, especially those for special services such as sewage handling, there is a demand for pumps of both rotations. A design with separate suction and seal chamber heads permits the use of the same casing for either rotation if the flanges on the two sides





**FIGURE 10** An axially split casing, horizontal-shaft, double-suction volute pump (Flowsolve Corporation)



**FIGURE 11** End-suction pump with semi-open impeller (Flowsolve Corporation)

are made identical. There is also a demand for vertical pumps that can be disassembled by removing the rotor and bearing assembly from the top of the casing. Many horizontal applications of the pumps of the same line, however, require partial dismantling from the suction side. Such lines are most adaptable when they have separate suction and casing covers.

**Casing Construction for Open- and Semiopen-Impeller Pumps** In the open- or semiopen impeller pump, the impeller rotates within close clearance of the pump casing or suction cover (refer to Figure 11). If the intended service is abrasive, a side plate is mounted within the casing to provide a renewable close-clearance guide to the liquid flow-

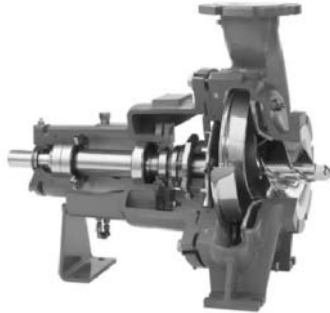


FIGURE 12 End-suction pump with semi-open impeller, inducer and renewable side plate (Flowserve Corporation)

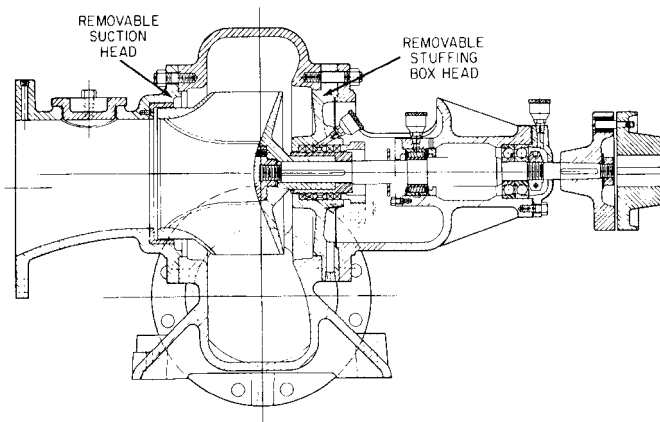


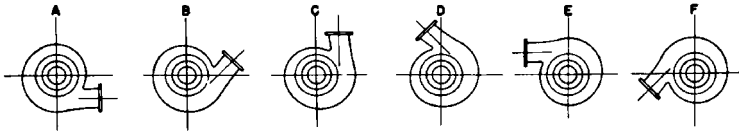
FIGURE 13 End-suction pump with removable suction and stuffing box heads (Flowserve Corporation)

ing through the impeller (refer to Figure 12). One of the advantages of using side plates is that abrasion-resistant material, such as stainless steel, can be used for the impeller and side plate, while the casing itself may be of a less costly material. Although double-suction, semiopen-impeller pumps are seldom used today, they were common in the past and were generally made with side plates.

In order to maintain pump efficiency, a close running clearance is required between the front unshrouded face of the open or semiopen impeller and the casing, suction cover, or side plate. Pump designs provide either jackscrews or shims to adjust the position of the thrust bearing housing (and, as a result, the axial position of the shaft and impeller) relative to the bearing frame.

**Pre-rotation and Stop Pieces** Improper entrance conditions and inadequate suction approach shapes may cause the liquid column in the suction pipe to spiral for some distance ahead of the impeller entrance. This phenomenon is called *pre-rotation*, and it is attributed to various operational and design factors in both vertical and horizontal pumps.

Pre-rotation is usually harmful to pump operation because the liquid enters between the impeller vanes at an angle other than that allowed in the design. This frequently lowers the net effective suction head and the pump efficiency. Various means are used to avoid pre-rotation both in the construction of the pump and in the design of the suction approaches.



**FIGURE 14** Possible positions of discharge nozzles for a specific design of an end-suction, solid-casing, horizontal-shaft pump. The rotation illustrated is counterclockwise from suction end.



**FIGURE 15** A bottom-suction, axially split casing single-stage pump (Flowsolve Corporation)

Practically all horizontal, single-stage, double-suction pumps and most multistage pumps have a suction volute that guides the liquid in a streamline flow to the impeller eye. The flow comes to the eye at right angles to the shaft and separates unequally on the two sides of the shaft. Moving from the suction nozzle to the impeller eye, the suction waterways are reduced in area, meeting in a projecting section of the sidewall dividing the two sections. This dividing projection is called a *stop piece*. To minimize pre-rotation in end-suction pumps, a radial-fin stop piece projecting toward the center is sometimes cast into the suction nozzle wall.

**Nozzle Locations** The discharge nozzle of end-suction, single-stage horizontal pumps is usually in a top-vertical position (refer to Figures 1, 11, and 12). However, other nozzle positions can be obtained, such as top-horizontal, bottom-horizontal, or bottom-vertical. Figure 14 illustrates the flexibility available in discharge nozzle locations. Sometimes the pump frame, bearing bracket, or baseplate may interfere with the discharge flange, prohibiting a bottom-horizontal or bottom-vertical discharge nozzle position. In other instances, solid casings cannot be rotated for various nozzle positions because the seal chamber connection would become inaccessible.

Practically all double-suction, axially split casing pumps have a side discharge nozzle and either a side- or a bottom-suction nozzle. If the suction nozzle is placed on the side of the pump casing with its axial centerline (refer to Figure 10), the pump is classified as a *side-suction pump*. If its suction nozzle points vertically downward (see Figure 15), the pump is called a *bottom-suction pump*. Single-stage, bottom-suction pumps are rarely made in sizes below a 10-in (254 mm) discharge nozzle diameter.

Special nozzle positions can sometimes be provided for double-suction, axially split casing pumps to meet special piping arrangements, such as a radically split casing with bottom suction and top discharge in the same half of the casing. Such special designs are generally costly and should be avoided.

**Centrifugal Pump Rotation** Because suction and discharge nozzle locations are affected by pump rotation, it is important to understand how the direction of rotation is defined. According to Hydraulic Institute standards, rotation is defined as clockwise or counterclockwise by looking at the driven end of a horizontal pump or looking down on a vertical pump. To avoid misunderstanding, clockwise or counterclockwise rotation should always be qualified by including the direction from which one looks at the pump.

The terms *inboard end* or *drive end* (the end of the pump closest to the driver) and *outboard end* or *nondrive end* (the end of the pump farthest from the driver) are used only with horizontal pumps. The terms lose their significance with dual-driven pumps. Any centrifugal pump casing pattern can be arranged for either clockwise or counterclockwise rotation, except for end-suction pumps, which have integral heads on one side. These require separate directional patterns.

**Casing Handholes** Casing handholes are furnished primarily on pumps handling sewage and stringy materials that may become lodged on the impeller suction vane edges or on the tongue of the volute. The holes permit removal of this material without completely dismantling the pump. End-suction pumps used primarily for liquids of this type are provided with handholes or access to the suction side of the impellers. These access points are located on the suction head or in the suction elbow. Handholes are also provided in drainage, irrigation, circulating, and supply pumps if foreign matter may become lodged in the waterways. On very large pumps, manholes provide access to the interior for both cleaning and inspection.

**Mechanical Features of Casings** Most single-stage centrifugal pumps are intended for service at moderate pressures and temperatures. As a result, pump manufacturers usually design a special line of pumps for high operating pressures and temperatures rather than make their standard line unduly expensive by making it suitable for too wide a range of operating conditions.

If axially split casings are subject to high pressure, they tend to “breathe” at the split joint, leading to misalignment of the rotor and, even worse, leakage. For such conditions, internal and external ribbing is applied to casings at the points subject to the greatest stress. In addition, whereas most pumps are supported by feet at the bottom of the casing, high temperatures require centerline support so that, as the pump becomes heated, expansion will not cause misalignment.

**Series Units** For large-capacity medium-high-head conditions, two single-stage, double-suction pumps can be connected in a series on one baseplate with a single driver. Such an arrangement was at one time very common in waterworks applications for heads of 250 to 400 ft (76 to 122 m). One series arrangement uses a double-extended shaft motor in the middle, driving two pumps connected in a series by external piping. In a second type, a standard motor is used with one pump having a double-extended shaft. This latter arrangement may have limited applications because the shaft of the pump next to the motor must be strong enough to transmit the total pumping horsepower. If the total pressure generated by such a series unit is relatively high, the casing of the second pump could require ribbing. Higher heads per stage are becoming more and more common, and series units are generally used in only very high ranges of total head.

## MULTISTAGE PUMP CASINGS

---

Although the majority of single-stage pumps are of the volute-casing type, both volute and diffuser casings are used in multistage pump construction. Because a volute casing gives rise to radial thrust, axially split multistage casings generally have staggered volutes so that the resultant of the individual radial thrusts is balanced out (see Figures 16 and 17). Both axially and radially split casings are used for multistage pumps. The choice between the two designs is dictated by the design pressure, with 2000 lb/in<sup>2</sup> (138 bar)<sup>o</sup> being typical for 3600-rpm axially split casing pumps.

<sup>o</sup>1 bar = 10<sup>5</sup> Pa

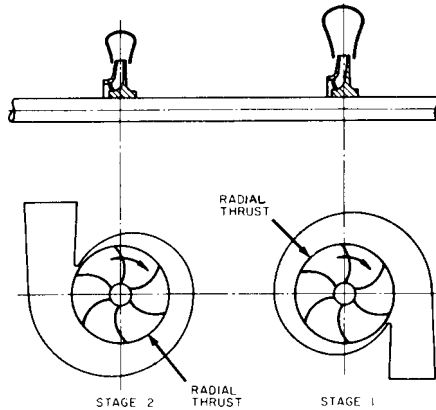


FIGURE 16 An arrangement of a multistage volute pump for radial-thrust balance

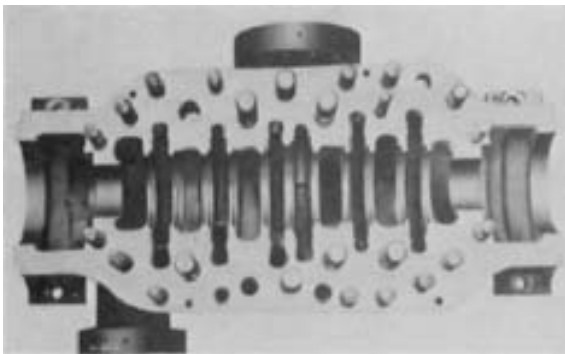
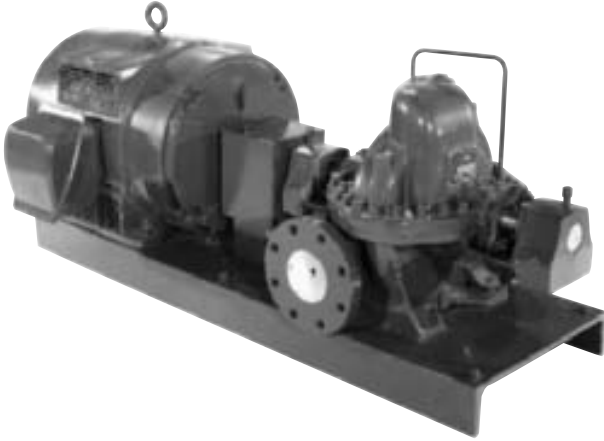


FIGURE 17 The horizontal flange of an axially split casing, six-stage pump (Flowserve Corporation)

**Axially Split Casings** Regardless of the arrangement of the stages in the casing, it is necessary to connect the successive stages of a multistage pump. In the low and medium pressure and capacity ranges, these interstage passages are cast integrally with the casing proper (see Figures 18 and 19). As the pressures and capacities increase, the desire to maintain as small a casing diameter as possible, coupled with the necessity of avoiding sudden changes in the velocity or the direction of the flow, leads to the use of external interstage passages cast separately from the pump casing. They are formed in the shape of a loop, bolted or welded to the casing proper (see Figure 20).

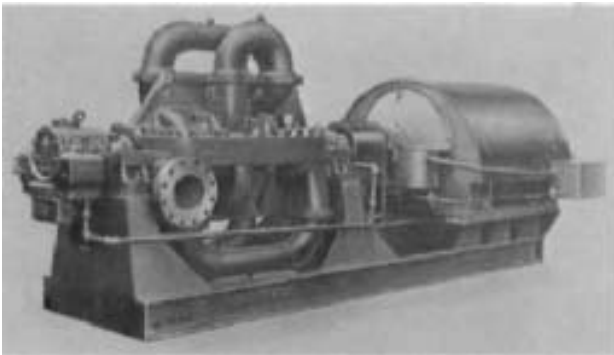
**Interstage Construction for Axially Split Casing Pumps** A multistage pump inherently has adjoining chambers subjected to different pressures, and means must be made available to isolate these chambers from one another so that the leakage from high to low pressure will take place only at the clearance joints formed between the stationary and rotating elements of the pump. Thus, the leakage will be kept to a minimum. The isolating wall used to separate two adjacent chambers of a multistage pump is called a *stage piece*, *diaphragm*, or *inter-stage diaphragm*. The stage piece may be formed of a single piece, or it may be fitted with a renewable stage piece bushing at the clearance joint between the stationary stage piece and the part of the rotor immediately inside the former. The stage pieces, which are usually solid, are assembled on the rotor along with impellers, sleeves, bearings,



**FIGURE 18** Two-stage axially split casing volute pump for small capacities and pressures up to 450 lb/in<sup>2</sup> (31 bar) (Flowserve Corporation)



**FIGURE 19** Two-stage axially split casing volute pump for pressures up to 500 lb/in<sup>2</sup> (34 bar) (Flowserve Corporation)



**FIGURE 20** A six-stage, axially split casing volute pump for pressures up to 1,300 lb/in<sup>2</sup> (90 bar) (Flowserve Corporation)

and similar components. To prevent the stage pieces from rotating, a locked tongue-and-groove joint is provided in the lower half of the casing. Clamping the upper casing half to the lower half securely holds the stage piece and prevents rotation.

The problem of seating a solid stage piece against an axially split casing is one that has given designers much trouble. First, there is a three-way joint and, second, this seating must make the joint tight and leakproof under a pressure differential without resorting to bolting the stage piece directly to the casing.

To overcome this problem, it is wise to make a pump that has a small-diameter casing so that when the casing bolting is pulled tight, there is a seal fitting of the two casing halves adjacent to the stage piece. The small diameter likewise helps to eliminate the possibility of a stage piece cocking and thereby leaving a clearance on the upper-half casing when it is pulled down. No matter how rigidly the stage piece is located in the lower-half casing, there must be a sliding fit between the seat face of the stage piece and that in the upper-half casing so that the upper-half casing can be pulled down. Each stage piece, furthermore, must be arranged so that the pressure differential developed by the pump will tend to seat the piece tightly against the casing rather than open up the joint.

We have said that axially split casing pumps are typically used for working pressures of up to 2,000 lb/in<sup>2</sup> (138 bar). High-pressure piping systems, of which these pumps form a part, are inevitably made of steel because this material has the valuable property of yielding without breaking. Considerable piping strains are unavoidable, and these strains, or at least a part thereof, are transmitted to the pump casing. The latter consists essentially of a barrel that is split axially, flanged at the split, and fitted with two necks that serve as inlet and discharge openings. When piping stresses exist, these necks, being the weakest part of the casing, are in danger of breaking off if they cannot yield. Steel is therefore the safest material for pump casings whenever the working pressures in the pump are in excess of 1,000 lb/in<sup>2</sup> (70 bar).

This brings up an important feature in the design of the suction and discharge flanges. Although raised-face flanges are perfectly satisfactory for steel-casing pumps, their use is extremely dangerous with cast-iron pumps. This danger arises from the lack of elasticity in cast iron, which leads to flange breakage when the bolts are being tightened, the fulcrum of the bending moment being located inward from the bolt circle. As a result, it is essential to avoid raised-face flanges with cast-iron casings as well as the use of a raised-face flange pipe directly against a flat-face cast-iron pump flange. Suction flanges should obviously be suitable for whatever hydrostatic test pressure is applied to the pump casing.

The location of the pump casing feet is not critical in smaller pumps operating at discharge pressures below 275 lb/in<sup>2</sup> (19 bar) and at moderate temperatures of up to 300°F (150°C). Since the unit is relatively small, very little distortion is likely to occur. However, for larger units operating at higher pressures and temperatures, it is important that the casing be supported at the horizontal centerline or immediately below the bearings (refer to Figures 19 and 20).

**Radially Split Double-Casing Pumps** The oldest form of radially split casing multi-stage pump is commonly called the *ring-section*, *ring-casing*, or the *doughnut type*. When more than one stage was found necessary to generate higher pressures, two or more single-stage units of the prevalent radially split casing type were assembled and bolted together.

In later designs, the individual stage sections and separate suction and discharge heads were held together with large throughbolts. These pumps, still an assembly of bolted-up sections, can present serious dismantling and reassembly problems because suction and discharge connections have to be broken each time the pump is serviced. The double-casing pump retains the advantages of the radially split casing design and minimizes the dismantling problem.

The basic principle consists of enclosing the working parts of a multistage centrifugal pump in an inner casing and building a second casing around this inner casing. The space between the two casings is maintained at the discharge pressure of the last pump stage. The construction of the inner casing follows one of two basic principles: (1) axial splitting (see Figure 21) or (2) radial splitting (see Figure 22).

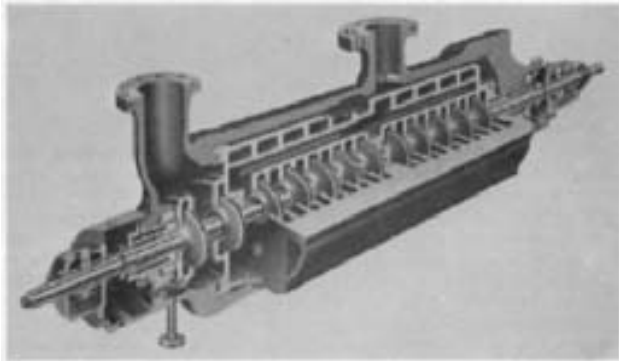


FIGURE 21 Double-casing multistage pump with axially split inner casing (Allis-Chalmers)



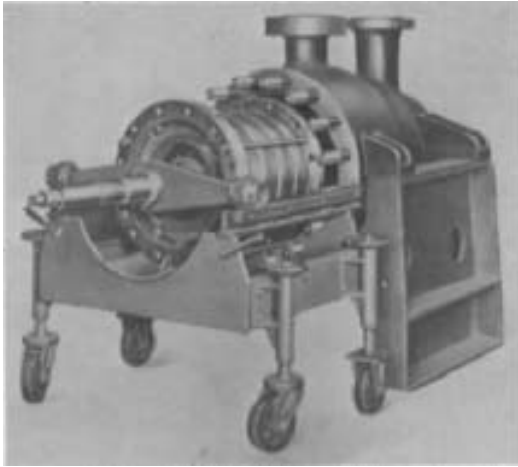
FIGURE 22 Double-casing multistage pump with radially split inner casing (Flowsolve Corporation)

The double-casing pump with radially split inner casing is an evolution of the ring-casing pump with added provisions to ease dismantling. The inner unit is generally constructed exactly as a ring-casing pump. After assembly, it is inserted and bolted inside a cylindrical casing that supports it and leaves it free to expand under temperature changes. In Figure 23, the inner assembly of such a pump is being inserted into the outer casing. Figure 24 shows the external appearance of this type of pump. The suction and discharge nozzles form an integral part of the outer casing, and the internal assembly of the pump can be withdrawn without disturbing the piping connections.

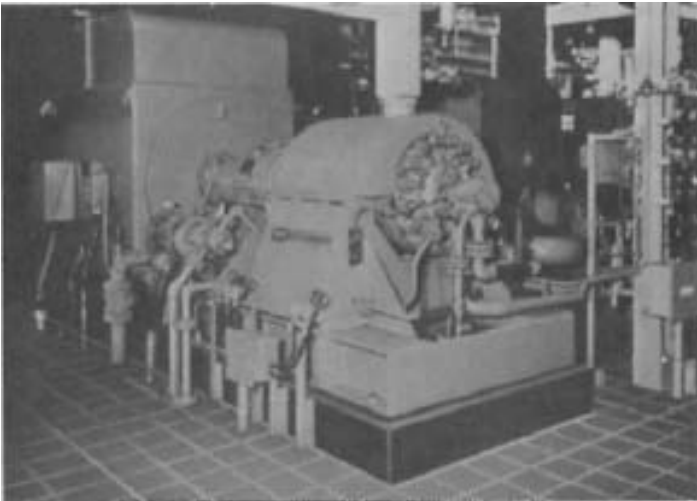
**Hydrostatic Pressure Tests** It is standard practice for the manufacturer to conduct hydrostatic tests for the parts of a pump that contain fluid under pressure. This means that the pump casing and, where applicable, parts like suction or casing covers are assembled with the internal parts, removed, and are then subjected to a hydrostatic test, generally for a minimum of 30 minutes. Such a test demonstrates that the casing containment is sound and that there is no leakage of fluid to the exterior.

Additional tests may be conducted by the pump manufacturer to determine the soundness of internal partitions separating areas of the pump operating under different pressures.





**FIGURE 23** Rotor assembly of a radially split, double-casing pump being inserted into its outer casing (Flowserve Corporation)



**FIGURE 24** Multistage radially split, double-casing pump (Flowserve Corporation)

The definition of the applicable hydrostatic pressure for these tests varies. The most generally accepted definition is that given by the Hydraulic Institute Standards. Each part of the pump that contains fluid under pressure shall be capable of withstanding a hydrostatic test at not less than the greatest of the following:

- 150 percent of the pressure that will occur in that part when the pump is operated at rated conditions for the given application of the pump, except thermoset parts
- 125 percent of the pressure that would occur in that part when the pump is operating at rated speed for a given application, but with the pump discharge valve closed

## IMPELLERS

In a single-suction impeller, the liquid enters the suction eye on one side only. A double-suction impeller is, in effect, two single-suction impellers arranged back to back in a single casing. The liquid enters the impeller simultaneously from both sides, while the two casing suction passageways are connected to a common suction passage and a single suction nozzle.

For the general service single-stage, axially split casing design, a double-suction impeller is favored because it is theoretically in an axial hydraulic balance and because the greater suction area of a double-suction impeller permits the pump to operate with less net absolute suction head. For small units, the single-suction impeller is more practical for manufacturing reasons, as the waterways are not divided into two very narrow passages. It is also sometimes preferred for structural reasons. End-suction pumps with single-suction overhung impellers have both first-cost and maintenance advantages unobtainable with double-suction impellers. Most radially split casing pumps therefore use single-suction impellers. Because an overhung impeller does not require the extension of a shaft into the impeller suction eye, single-suction impellers are preferred for pumps handling suspended matter, such as sewage. In multistage pumps, single-suction impellers are almost universally used because of the design and first-cost complexity that double-suction staging introduces.

Impellers are called radial vane or radial flow when the liquid pumped is made to discharge radially to the periphery. Impellers of this type usually have a specific speed below 4200 (2600) if single-suction and below 6000 (3700) if double-suction. Specific speed is discussed in detail in Subsection 2.3.1. The units for specific speed used here are in USCS rpm, gallons per minute, and feet. In SI, they are rpm, liters per second, and meters. Impellers can also be classified by the shape and form of their vanes:

- The straight-vane impeller (see Figures 25, 34, 35, 36, and 37)
- The Francis-vane or screw-vane impeller (see Figures 26 and 27)
- The mixed-flow impeller (see Figure 28)
- The propeller or axial-flow impeller (see Figure 29)

In a *straight-vane radial impeller*, the vane surfaces are generated by straight lines parallel to the axis of rotation. These are also called *single-curvature vanes*. The vane surfaces of a *Francis-vane radial impeller* have a double curvature. An impeller design that has both a radial-flow and an axial-flow component is called a *mixed-flow impeller*. It is generally restricted to single-suction designs with a specific speed above 4200 (2600). Types with lower specific speeds are called *Francis-vane impellers*. Mixed-flow impellers with a small radial-flow component are usually referred to as propellers. In a true propeller, or *axial-flow impeller*, the flow strictly parallels the axis of rotation. In other words, it moves only axially.

An inducer is a low-head, axial-flow impeller with few blades that is placed in front of a conventional impeller. The hydraulic characteristics of an inducer are such that it requires considerably less NPSH than a conventional impeller. Both inducer and impeller



FIGURE 25 Straight-vane, radial, single-suction closed impeller (Flowsolve Corporation)



**FIGURE 26** Francis-vane, radial, double-suction closed impeller (Flowserve Corporation)



**FIGURE 27** High-specific-speed, Francis-vane, radial, double-suction closed impeller (Flowserve Corporation)



**FIGURE 28** Open mixed-flow impeller (Flowserve Corporation)



**FIGURE 29** Axial-flow impeller (Flowserve Corporation)

are mounted on the same shaft and rotate at the same speed (see Figure 30). The main purpose of the inducer is not to generate an appreciable portion of the total pump head, but to increase the suction pressure to a conventional impeller. Inducers are therefore used to reduce the NPSH requirements of a given pump or to permit the pump to operate at higher speeds with a given available NPSH. For a further discussion of inducers, see Section 2.1 and Subsection 2.3.1.

The relation of single-suction impeller profiles to specific speed is shown in Figure 31. The classification of impellers according to their vane shape is naturally arbitrary inasmuch as there is much overlapping in the types of impellers used in the different types of pumps. For example, impellers in single- and double-suction pumps of low specific speeds have vanes extending across the suction eye. This provides a mixed flow at the impeller entrance for low pickup losses at high rotative speeds but enables the discharge portion of the impeller to use the straight-vane principle. In pumps of higher specific speed operating against low heads, impellers have double-curvature vanes extending over the full vane surface. They are therefore full Francis-type impellers. The mixed-flow impeller, usually a single-suction type, is essentially one-half of a double-suction, high-specific-speed, Francis-vane impeller.

In addition, many impellers are designed for specific applications. For instance, the conventional impeller design with sharp vane edges and restricted areas is not suitable for handling liquids containing rags, stringy materials, and solids like sewage because it will become clogged. Special nonclogging impellers with blunt edges and large waterways have been developed for such services (see Figure 32). For pumps up to the 12- to 16-in (305- to 406-mm) discharge size, these impellers have only two vanes. Larger pumps normally use three or four vanes.

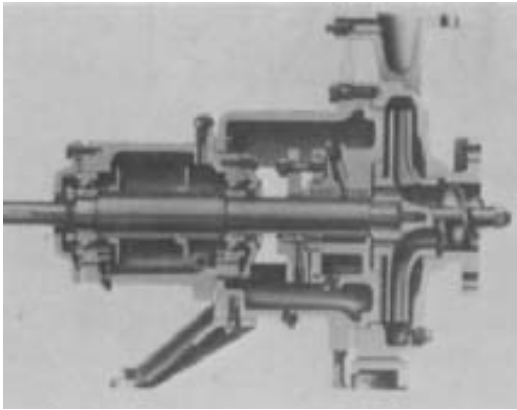


FIGURE 30 A centrifugal pump with a conventional impeller preceded by an inducer (Flowserve Corporation)

Another impeller design used for paper pulp pumps (see Figure 33) is fully open and nonclogging; it has screw and radial streamlined vanes. The screw-conveyor end projects far into the suction nozzle, permitting the pump to handle high-consistency paper pulp stock.

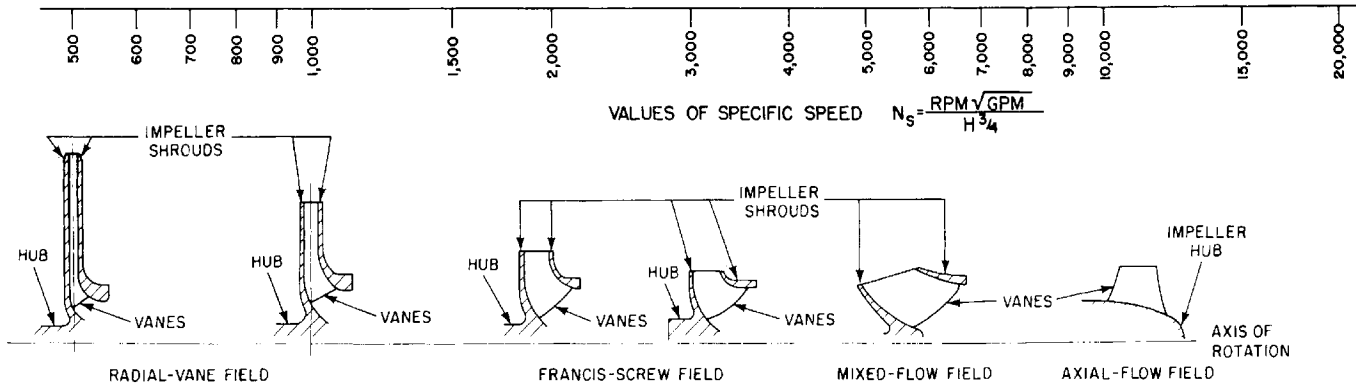
**Impeller Mechanical Types** Mechanical design also determines impeller classification. Accordingly, impellers may be completely open, semiopen, or closed.

Strictly speaking, an *open impeller* (see Figures 34 and 35) consists of nothing but vanes attached to a central hub for mounting on the shaft without any form of sidewall or shroud. The disadvantage of this impeller is structural weakness. If the vanes are long, they must be strengthened by ribs or a partial shroud. Generally, open impellers are used in small, low energy pumps. One advantage of open impellers is that they are better suited for handling liquids containing stringy materials. It is also sometimes claimed that they are better suited for handling liquids containing suspended matter because the solids in such matter are more likely to be clogged in the space between the rotating shrouds of a closed impeller and the stationary casing walls. It has been demonstrated, however, that closed impellers do not clog easily, thus disproving the claim for the superiority of the open-impeller design. In addition, the open impeller is much more sensitive to wear than the closed impeller and therefore its efficiency may deteriorate rather rapidly.

The open impeller rotates between two side plates, between the casing walls of the volute, or between the casing cover and the suction head. The clearance between the impeller vanes and the sidewalls enables a certain amount of water slippage. This slippage increases as wear increases. To restore the original efficiency, both the impeller and the side plate(s) must be replaced. This, incidentally, involves a much larger expense than would be entailed in closed impeller pumps where simple rings form the leakage joint.

The *semiopen impeller* (see Figure 36) incorporates a single shroud, usually at the back of the impeller. This shroud may or may not have *pump-out vanes*, which are vanes located at the back of the impeller shroud (see Figure 37). This function reduces the pressure at the back hub of the impeller and prevents foreign matter from lodging in back of the impeller that would interfere with the proper operation of the pump and the seal chamber.

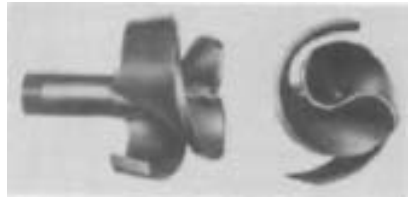
The *closed impeller* (refer to Figures 25 through 27), which is almost universally used in centrifugal pumps handling clear liquids, incorporates shrouds or sidewalls that totally enclose the impeller waterways from the suction eye to the periphery. Although this design prevents the liquid slippage that occurs between an open or semiopen impeller and its side plates, a running joint must be provided between the impeller and the casing to separate the discharge and suction chambers of the pump. This running joint is usually formed by a relatively short cylindrical surface on the impeller shroud that rotates within a slightly larger stationary cylindrical surface. If one or both surfaces are made renewable, the leakage joint can be repaired when wear causes excessive leakage.



**FIGURE 31** Variations in impeller profiles with specific speeds and approximate ranges of specific speeds for the various types. [Universal specific speed  $\Omega_s = N_s/2733$ .  $N_s$  (in rpm,  $\text{m}^3/\text{s}, \text{m}) = N_s/51.65$ ].



**FIGURE 32** Phantom view of a radial-vane nonlogging impeller (Flowserve Corporation)



**FIGURE 33** Paper plug impeller (Flowserve Corporation)



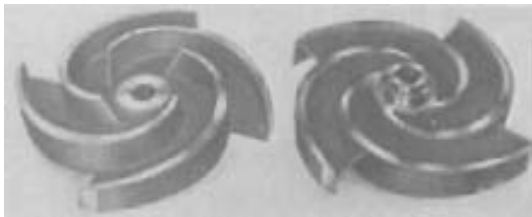
**FIGURE 34** Open impellers. Notice that the impellers at left and right are strengthened by a partial shroud (Flowserve Corporation).



**FIGURE 35** An open impeller with partial shroud (Flowserve Corporation)



**FIGURE 36** Semiopen impeller (Flowserve Corporation)



**FIGURE 37** The front and back views of an open impeller with a partial shroud and pump-out vanes on the back side (Flowserve Corporation)

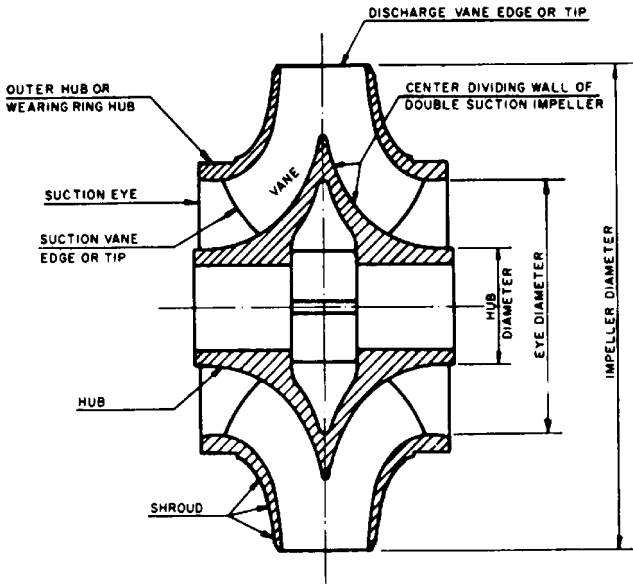


FIGURE 38 Parts of a double-suction impeller

If the pump shaft terminates at the impeller so that the latter is supported by bearings on one side, the impeller is called an *overhung impeller*. This type of construction is the best for end-suction pumps with single-suction impellers.

**Impeller Nomenclature** The inlet of an impeller just before the section where the vanes begin is called the suction eye (see Figure 38). In a closed-impeller pump, the suction eye diameter is taken as the smallest inside diameter of the shroud. In determining the area of the suction eye, the area occupied by the impeller shaft hub is deducted.

The *hub* is the central part of the impeller that is bored out to receive the pump shaft. The term, however, is also frequently used for the part of the impeller that rotates in the casing fit or in the casing wearing ring. It is then referred to as the *outer impeller hub* or the *wearing-ring hub* of the shroud.

## WEARING RINGS

Wearing rings provide an easily and economically renewable leakage joint between the impeller and the casing. A leakage joint without renewable parts is illustrated in Figure 39. To restore the original clearances of such a joint after wear occurs, the user must either (1) build up the worn surfaces by welding or metal spraying, or (2) buy new parts.

The new parts are not very costly in small pumps, especially if the stationary casing element is a simple suction cover. This is not true for larger pumps or where the stationary element of the leakage joint is part of a complicated casting. If the first cost of a pump is of prime importance, it is more economical to provide for remachining both the stationary parts and the impeller. Renewable casing and impeller rings can then be installed (see Figures 40, 41, and 42). The nomenclature for the casing or stationary part forming the leakage joint surface is as follows: (1) *casing ring* (if mounted in the casing), (2) *casing ring* or *suction head ring* (if mounted in a suction cover or head), and (3) *casing cover ring* or *head ring* (if mounted in the casing cover or head). Some engineers like to identify the part

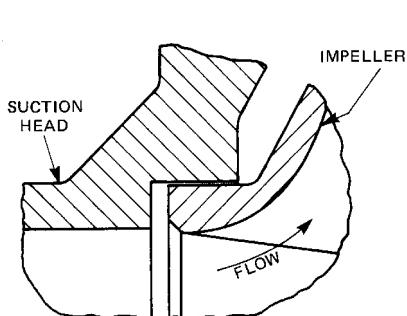


FIGURE 39 A plain flat leakage joint with no rings

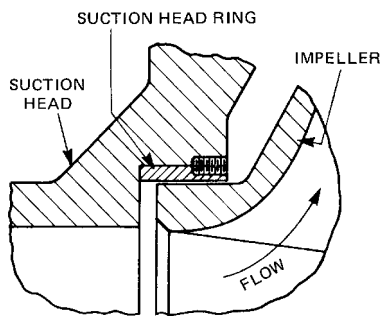


FIGURE 40 A single flat casing ring construction.

further by adding the word *wearing*, such as *casing wearing ring*. A renewable part for the impeller wearing surface is called the *impeller ring*. Pumps with both stationary and rotating rings are said to have *double-ring construction*.

**Wearing Ring Types** Various types of wearing ring designs, and the selection of the most desirable type depends on the liquid being handled, the pressure differential across the leakage joint, the rubbing speed, and the particular pump design. In general, centrifugal pump designers use the ring construction that they have found to be most suitable for each particular pump service.

The most common ring constructions are the flat type (see Figures 40 and 41) and the L type. The leakage joint in the former is a straight, annular clearance. In the L-type ring (see Figure 43), the axial clearance between the impeller and the casing ring is large, so the velocity of the liquid flowing into the stream entering the suction eye of the impeller is low. The L-type casing rings shown in Figures 43 and 44 have the additional function of guiding the liquid into the impeller eye; they are called *nozzle rings*. Impeller rings of the L type shown in Figure 44 also furnish protection for the face of the impeller wearing ring hub.

Some designers favor labyrinth-type rings (see Figures 45 and 46) that have two or more annular leakage joints connected by relief chambers. In leakage joints involving a single unbroken path, the flow is a function of both the area and the length of the joint as well as of the pressure differential across the joint. If the path is broken by relief chambers (see to Figure 42, 45, and 46), the velocity energy in the jet is dissipated in each relief chamber, increasing the resistance. As a result, with several relief chambers and several leakage joints for the same actual flow through the joint, the area and hence the clearance between the rings can be greater than for an unbroken, shorter leakage joint.

The single labyrinth ring with only one relief chamber (refer to Figure 45) is often called an *intermeshing ring*. The *step-ring type* (refer to Figure 42) utilizes two flat-ring elements of slightly different diameters over the total leakage joint width with a relief chamber between the two elements. Other ring designs also use some form of relief chamber. For example, one commonly used in small pumps has a flat joint similar to that in Figure 40, but with one surface broken by a number of grooves. These act as relief chambers to dissipate the jet velocity head, thereby increasing the resistance through the joint and decreasing the leakage.

For raw water pumps in waterworks service and for larger pumps in sewage services in which the liquid contains sand and grit, *water-flushed rings* have been used (see Figure 47). Clear water under a pressure greater than that on the discharge side of the rings is piped to the inlet and distributed by the cored passage, the holes through the stationary ring, and the groove to the leakage joint. Ideally, the clear water should fill the leakage joint with some flow to the suction and discharge sides to prevent any sand or grit from getting into the clearance space. Wearing-ring flush is also employed in some process pumps when pumping solids or abrasives to minimize ring wear by injecting a compatible clean liquid between the rings.



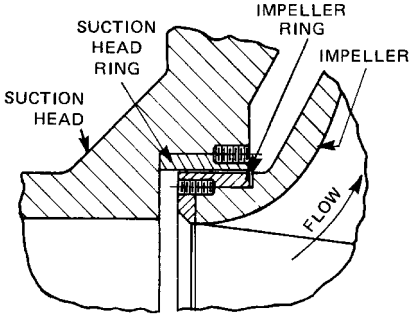


FIGURE 41 A double flat ring construction

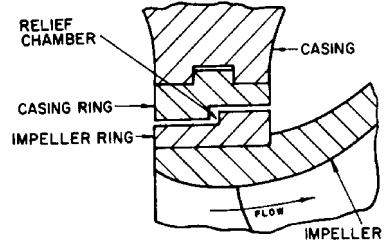


FIGURE 42 A step-type leakage joint with double rings

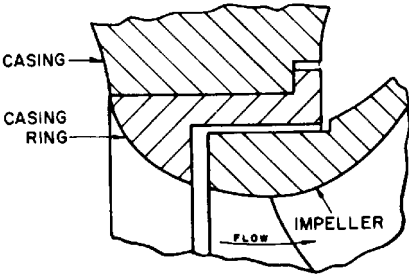


FIGURE 43 An L-type nozzle casing ring

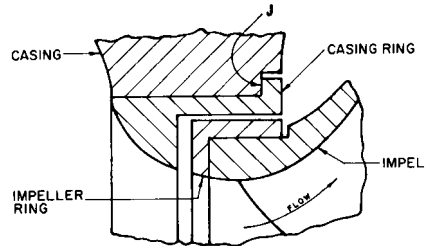


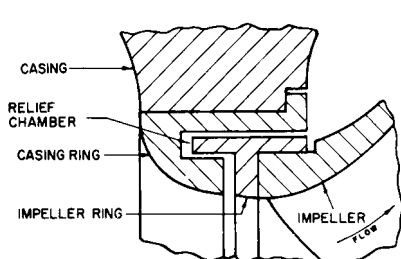
FIGURE 44 Double rings, both of L type

In large pumps (with roughly a 36-in [900-mm] or larger discharge size), particularly vertical, end-suction, single-stage volute pumps, size alone permits some refinements not found in smaller pumps. One example is the inclusion of inspection ports for measuring ring clearance (see Figure 48). These ports can be used to check the impeller centering after the original installation as well as to observe ring wear without dismantling the pump.

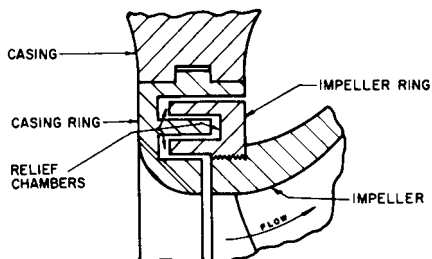
The lower rings of large vertical pumps handling liquids containing sand and grit in intermittent services are highly susceptible to wear. During shutdown periods, the grit and sand settle out and naturally accumulate in the region where these rings are installed, as it is the lowest point on the discharge side of the pump. When the pump is started again, this foreign matter is washed into the joint all at once and causes wear. To prevent this action in medium and large pumps, a dam-type ring is often used (see Figure 49). Periodically, the pocket on the discharge side of the dam can be flushed out.

One problem with the simple water-flushed ring is the failure to get uniform pressure in the stationary ring groove. If pump size and design permit, two sets of wearing rings arranged in tandem and separated by a large water space (see Figure 50) provide the best solution. The large water space enables a uniform distribution of the flushing water to the full 360° degrees of each leakage joint. Because ring 2 is shorter and because a greater clearance is used there than at ring 1, equal flow can take place to the discharge pressure side and to the suction pressure side. This design also makes it easier to harden or coat the surfaces.

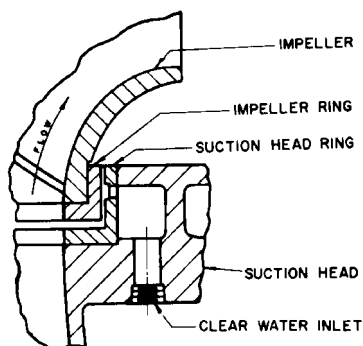
For pumps handling gritty or sandy water, the ring construction should provide an apron on which the stream leaving the leakage joint can impinge, as sand or grit in the jet will erode any surface it hits. Thus, a form of L-type casing ring similar to that shown in Figure 49 should be used.



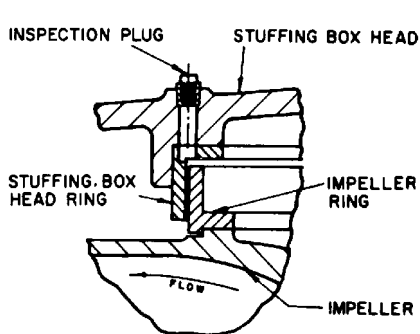
**FIGURE 45** A single-labyrinth, intermeshing type. It is a double-ring construction with a nozzle-type casing ring.



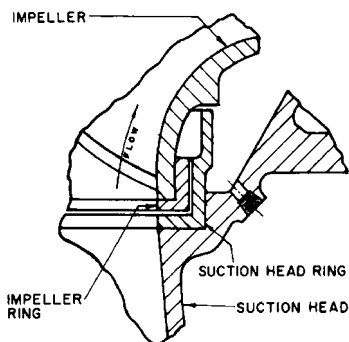
**FIGURE 46** Labyrinth-type rings in a double-ring construction



**FIGURE 47** Water-flushed wearing ring



**FIGURE 48** Wearing ring with an inspection port for checking clearance



**FIGURE 49** Dam-type ring construction

**Wearing-Ring Location** In some designs, leakage is controlled by an axial clearance (see Figure 51). Generally, this design requires a means of adjusting the shaft position for proper clearance. Then, if uniform wear occurs over the two surfaces, the original clearance can be restored by adjusting the position of the impeller. A limit exists to the amount of wear that can be compensated, because the impeller must be nearly central in the casing waterways.

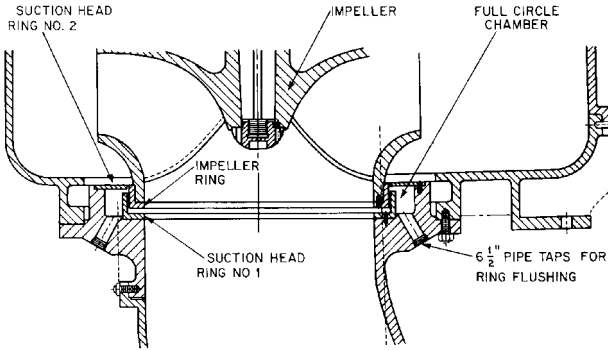


FIGURE 50 Two sets of rings with space between for flushing water (Flowserve Corporation)

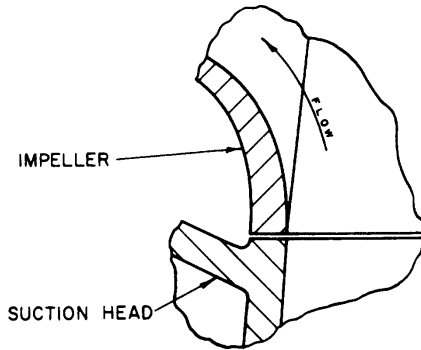


FIGURE 51 A leakage joint with axial clearance

Leakage joints with axial clearance are not popular for double-suction pumps because a very close tolerance is required in machining the fit of the rings in reference to the centerline of the volute waterways. Joints with radial clearances, however, enable some shifting of the impeller for centering. The only adverse effect is a slight inequality in the lengths of the leakage paths on the two sides.

So far, this discussion has treated only those leakage joints located adjacent to the impeller eye or at the smallest outside shroud diameter. Designs have been made where the leakage joint is at the periphery of the impeller. In a vertical pump, this design is advantageous because the space between the joint and the suction waterways is open and so sand or grit cannot collect. Because of rubbing speed and because the impeller diameters used in the same casing vary over a wide range, the design is impractical in regular pump lines.

**Mounting Stationary Wearing Rings** In small single-suction pumps with suction heads, a stationary wearing ring is usually pressed into a bore in the head and may or may not be further locked by several set screws located half in the head and half in the ring (refer to Figure 41). Larger pumps often use an L-type ring with the flange held against a face on the head. In axially split casing pumps, the cylindrical casing bore (in which the casing ring will be mounted) should be slightly larger than the outside diameter of the ring. Unless some clearance is provided, distortion of the ring may occur when the two casing halves are assembled. However, the joint between the casing ring and the

casing must be tight enough to prevent leakage. This is usually provided by a radial metal-to-metal joint (refer to Figure 43) arranged so that the discharge pressure presses the ring against the casing surface.

As it is not desirable for the casing ring of an axially split casing pump to be pinched by the casing, the ring will not be held tightly enough to prevent its rotation unless special provisions are made to keep it in place. One means of accomplishing this is to place a pin in the casing that will project into a hole bored in the ring or, conversely, to provide a pin in the ring that will fit into a hole bored in the casing or into a recess at the casing split joint.

Another method is to have a tongue on the casing ring that extends around 180° and engages a corresponding groove in one-half of the casing. This method can be used with casing rings having a central flange by making the diameter of the flange larger for 180° and cutting a deeper groove in that half of the casing.

Many methods are used for holding impeller rings on the impeller. Probably the simplest is to rely on a press fit of the ring on the impeller or, if the ring is of proper material, on a shrink fit. Designers do not usually feel that a press fit is sufficient and often add several machine screws or set screws located half in the ring and half in the impeller, as in Figure 41.

An alternative to axial machine screws being located half in the ring and half in the impeller is the radial pin, which goes through the center of the ring into the impeller (or from the inside of the impeller eye outward into the ring). This pinning method avoids having to drill and tap holes half in a hardened wearing ring and half in a softer impeller hub. For higher speeds, installing the radial pins from the inside of the impeller eye outward into the wearing ring captures the pins and protects against pin loss, especially at higher operating speeds. Generally, some additional locking method is used rather than relying solely on friction between the ring and the impeller.

In the design of impeller rings, consideration has to be given to the stretch of the ring caused by centrifugal force, especially if the pump is of a high-speed design for the capacity involved. For example, some pumps operate at speeds that would cause the rings to become loose if only a press fit is used. For such pumps, shrink fits should be used or, preferably, impeller rings should be eliminated.

**Wearing-Ring Clearances** Typical clearance and tolerance standards for nongalling wearing-joint metals in general service pumps are shown in Figure 52. They apply to the

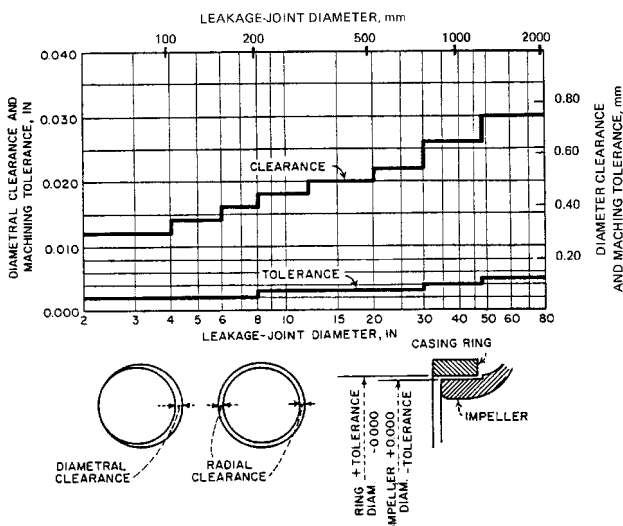


FIGURE 52 Wearing-ring clearances for single-stage pumps using nongalling materials

following combinations: (1) bronze with a dissimilar bronze, (2) cast-iron with bronze, (3) steel with bronze, (4) Monel metal with bronze, and (5) cast-iron with cast iron. If the metals gall easily (like the chrome steels), the values given should be increased by 0.002 to 0.004 in.

The tolerance indicated is positive for the casing ring and negative for the impeller hub or impeller ring.

In a single-stage pump with a joint of nongalling components, the correct machining dimension for a casing-ring diameter of 9.000 in would be 9.000 plus 0.003 and minus 0.000 in. For the impeller hub or ring, the values would be 9.000 minus 0.018 (or 8.982) plus 0.000 and minus 0.003 in. Diametral clearances would be between 0.018 and 0.024 in. Obviously, clearances and tolerances are not translated into SI units by merely using conversion multipliers; they are rounded off as they are in the USCS system. The SI values for the previous USCS examples given are outlined here.

For a single-stage pump with a casing ring diameter of 230 millimeters, the machining dimensions would be as follows:

Casing ring	230 plus 0.08 and minus 0.00 mm
Impeller hub	230 minus 0.50 (229.5) plus 0.00 and minus 0.08 mm
Diametral clearances	Between 0.50 and 0.66 mm

Naturally, the manufacturer's recommendation for ring clearances and tolerances should be followed.

## AXIAL THRUST

**Axial Thrust in Single-Stage Pumps with Closed Impellers** The pressures generated by a centrifugal pump exert forces on both stationary and rotating parts. The design of these parts balances some of these forces, but separate means may be required to counterbalance others.

An axial hydraulic thrust on an impeller is the sum of the unbalanced forces acting in the axial direction. Because reliable, large-capacity thrust bearings are readily available, an axial thrust in single-stage pumps remains a problem only in larger, higher speed units. Theoretically, a double-suction impeller is in hydraulic axial balance, with the pressures on one side equal to and counterbalancing the pressures on the other (see Figure 53). In practice, this balance may not be achieved for the following reasons:

1. The suction passages to the two suction eyes may not provide equal or uniform flows to the two sides.
2. External conditions, such as an elbow located too close to the pump suction nozzle, may cause unequal flow to the two suction eyes.

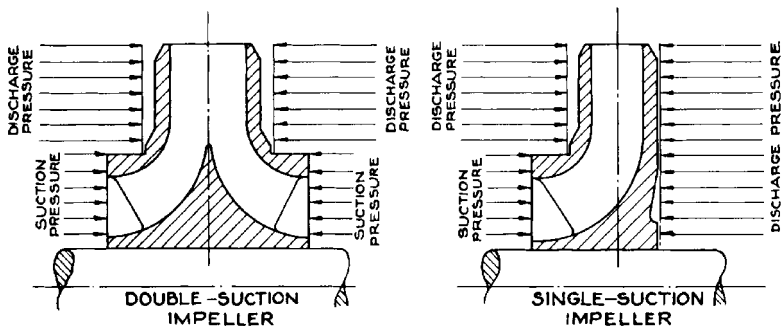


FIGURE 53 The origin of pressures acting on impeller shrouds to produce an axial thrust

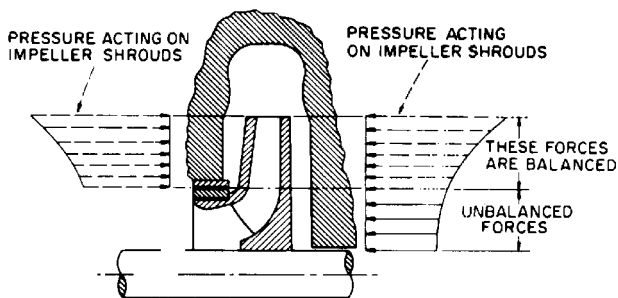
3. The two sides of the discharge casing waterways may not be symmetrical, or the impeller may be located off-center. These conditions will alter the flow characteristics between the impeller shrouds and the casing, causing unequal pressures on the shrouds.
4. Unequal leakage through the two leakage joints can upset the balance.

Combined, these factors can create an axial unbalance. To compensate for this, all centrifugal pumps, even those with double-suction impellers, incorporate thrust bearings.

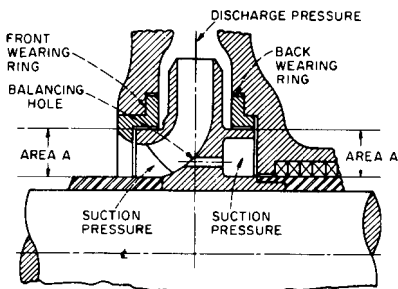
The ordinary single-suction, closed, radial-flow impeller with the shaft passing through the impeller eye (refer to Figure 53) is subject to an axial thrust because a portion of the front wall is exposed to suction pressure and thus relatively more backwall surface is exposed to discharge pressure. If the discharge chamber pressure is uniform over the entire impeller surface, the axial force acting toward the suction would be equal to the product of the net pressure generated by the impeller and the unbalanced annular area.

Actually, pressure on the two single-suction, closed impeller walls is not uniform. The liquid trapped between the impeller shrouds and casing walls is in rotation, and the pressure at the impeller periphery is appreciably higher than the impeller hub. Although we need not be concerned with the theoretical calculations for this pressure variation, Figure 54 describes it qualitatively. Generally speaking, the axial thrust toward the impeller suction may be about 20 to 30 percent less than the product of the net pressure and the unbalanced area.

To eliminate the axial thrust of a single-suction impeller, a pump can be provided with both front and back wearing rings. To equalize the thrust areas, the inner diameter of both rings is made the same (see Figure 55). Pressure approximately equal to the suction pressure is maintained in a chamber located on the impeller side of the back wearing ring by



**FIGURE 54** Pressure distribution on the front and back shrouds of the single-suction impeller with a shaft through the impeller eye



**FIGURE 55** Balancing the axial thrust of a single-suction impeller by means of wearing rings on the back side and balancing holes

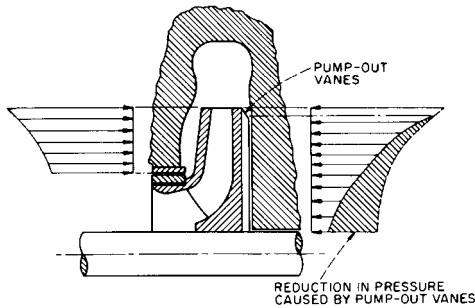


FIGURE 56 Pump-out vanes used in a single-suction impeller to reduce axial thrust

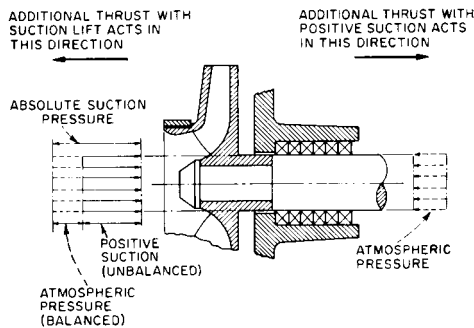


FIGURE 57 An axial thrust problem with a single-suction, overhung impeller and a single stuffing box or seal chamber

drilling balancing holes through the impeller. Leakage past the back wearing ring is returned to the suction area through these holes. However, with large single-stage, single-suction pumps, balancing holes are considered undesirable because leakage back to the impeller suction opposes the main flow, creating disturbances. In such pumps, a piped connection to the pump suction replaces the balancing holes.

Another way to eliminate or reduce an axial thrust in single-suction impellers is to use pump-out vanes on the back shroud. The effect of these vanes is to reduce the pressure acting on the back shroud of the impeller (see Figure 56). This design, however, is generally used only in pumps handling dirty liquids where it keeps the clearance space between the impeller back shroud and the casing free of foreign matter.

So far, our discussion of axial thrust has been limited to single-suction, closed impellers with a shaft passing through the impeller eye that are located in pumps with two seal chambers, one on either side of the impeller. In these pumps, suction-pressure magnitude does not affect the resulting axial thrust.

On the other hand, axial forces acting on an overhung impeller with a single seal chamber (see Figure 57) are definitely affected by suction pressure. In addition to the unbalanced force found in a single-suction, two-seal chamber design (refer to Figure 54), there is an axial force equivalent to the product of the shaft area through the seal chamber and the difference between suction and atmospheric pressure. This force acts toward the impeller suction when the suction pressure is less than atmospheric or in the opposite direction when it is higher than atmospheric.

When an overhung impeller pump handles a suction lift, the additional axial force is very low. For example, if the shaft diameter through the stuffing box is 2 in (50.8 mm)

(area =  $3.14 \text{ in}^2$  or  $20.26 \text{ cm}^2$ ), and if the suction lift is 20 ft (6.1 m) of water equivalent to an absolute pressure of  $6.06 \text{ lb/in}^2$  (0.42 bar abs), the axial force caused by the overhung impeller and acting toward the suction will be only 27 lb (121 N). On the other hand, if the suction pressure is  $100 \text{ lb/in}^2$  (6.89 bar), the force will be 314 lb (1405 N) and will act in the opposite direction. Therefore, because the same pump may be used under many conditions over a wide range of suction pressures, the thrust bearing of pumps with single-suction, overhung impellers must be arranged to take the thrust in either direction. They must also be selected with a sufficient thrust capacity to counteract forces set up under the maximum suction pressure established for that particular pump.

This extra thrust capacity can become quite significant in certain special cases, such as with boiler circulating pumps. These are usually of the single-suction, single-stage, overhung impeller type and may be exposed to suction pressures as high as  $2800 \text{ lb/in}^2$  gage (193 bar). This is approximately the vapor pressure of  $685^\circ\text{F}$  ( $363^\circ\text{C}$ ) boiler water. If such a pump has a shaft diameter of 6-in (15.24 cm), the unbalanced thrust would be as much as 77,500 lb (346,770 N), and the thrust bearing has to be capable of counteracting this.

**Axial Thrust of Single-Suction Semiopen Radial-Flow Impellers** The axial thrust generated in semiopen impellers is higher than that in closed impellers. This is illustrated in Figure 58, which shows that the pressure on the open side of the impeller varies from essentially the discharge pressure at the periphery (at diameter  $D_2$ ) to the suction pressure at the impeller eye (at diameter  $D_1$ ). The pressure distribution on the back shroud is essentially the same as that illustrated in Figure 54, varying from discharge pressure at the periphery to some portion of this pressure at the impeller hub. This latter pressure is, of course, substantially higher than the suction pressure. The unbalanced portion of the axial thrust on the impeller is represented by the cross-hatched area in Figure 58.

One of the means available for partially balancing this increased axial thrust is to provide the back shroud with pump-out vanes, as in Figures 37 and 56.

Fully open impellers or semiopen impellers with a portion of the back shroud removed produce an axial thrust somewhat higher than closed impellers and somewhat lower than semiopen impellers.

**Axial Thrust of Mixed-Flow and Axial-Flow Impellers** The axial thrust in radial impellers is produced by the static pressures on the impeller shrouds. Axial-flow impellers have no shrouds, and the axial thrust is created strictly by the difference in pressure on the two faces of the impeller vanes. In addition, a difference may exist in pressure acting on the two shaft hub ends, one generally subject to discharge pressure and the other to suction pressure.

With mixed-flow impellers, axial thrust is a combination of forces caused by the action of the vanes on the liquid and those arising from the difference in the pressures acting on the various surfaces. Wearing rings are often provided on the back of mixed-flow impellers, with either balancing holes through the impeller hub or an external balancing pipe leading back to the suction.

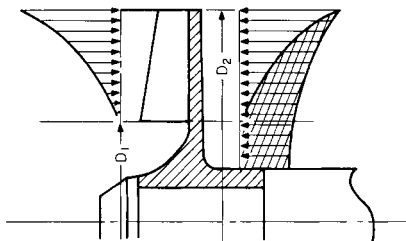
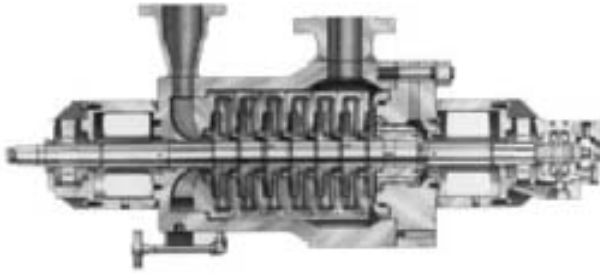
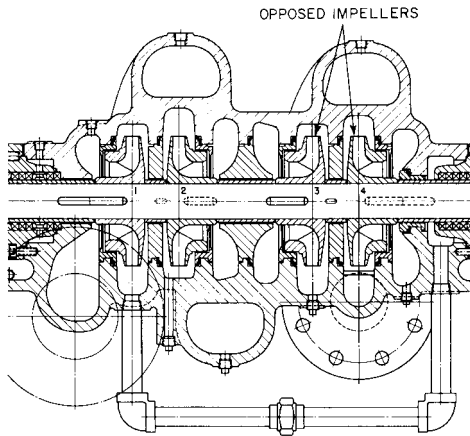


FIGURE 58 Axial thrust in a semiopen single-suction impeller





**FIGURE 59** Multistage pump with single-suction impellers facing in one direction and hydraulic balancing device (Flowsolve Corporation)



**FIGURE 60** A four-stage pump with opposed impellers (Flowsolve Corporation)

Except for very large units and in certain special applications, the axial thrust developed by mixed-flow and axial-flow impellers is carried by thrust bearings with the necessary load capacity.

**Axial-Thrust in Multistage Pumps** Most multistage pumps are built with single-suction impellers in order to simplify the design of the interstage connections. Two obvious arrangements are possible for the single-suction impellers:

1. Several single-suction impellers can be mounted on one shaft, each having its suction inlet facing in the same direction and its stages following one another in ascending order of pressure (see Figure 59). The axial thrust is then balanced by a hydraulic balancing device.
2. An even number of single-suction impellers can be used, one-half facing in one direction and the other half facing in the opposite direction. With this arrangement, an axial thrust on the first half is compensated by the thrust in the opposite direction on the other half (see Figure 60). This mounting of single-suction impellers back to back is frequently called *opposed impellers*.

An uneven number of single-suction impellers can be used with this arrangement, provided the correct shaft and interstage bushing diameters are used to give the effect of a hydraulic balancing device that will compensate for the hydraulic thrust on one of the stages.

It is important to note that the opposed impeller arrangement completely balances an axial thrust only under the following conditions:

- The pump must be provided with two seal chambers.
- The shaft must have a constant diameter.
- The impeller hubs must not extend through the interstage portion of the casing separating adjacent stages.

Except for some special pumps that have an internal and enclosed bearing at one end, and therefore only one seal chamber, most multistage pumps fulfill the first condition. Because of structural requirements, however, the last two conditions are not practical. A slight residual thrust is usually present in multistage opposed impeller pumps and is carried on the thrust bearing.

### HYDRAULIC BALANCING DEVICES

If all the single-suction impellers of a multistage pump face the same direction, the total theoretical hydraulic axial thrust acting toward the suction end of the pump will be the sum of the individual impeller thrusts. The thrust magnitude will be approximately equal to the product of the net pump pressure and the annular unbalanced area. Actually, the axial thrust turns out to be about 70 to 80 percent of this theoretical value.

Some form of hydraulic balancing device must be used to balance this axial thrust and to reduce the pressure on the seal chamber adjacent to the last-stage impeller. This hydraulic balancing device may be a balancing drum, a balancing disk, or a combination of the two.

**Balancing Drums** The balancing drum is illustrated in Figure 61. The balancing chamber at the back of the last-stage impeller is separated from the pump interior by a drum that is usually keyed to the shaft and rotates with it. The drum is separated by a small radial clearance from the stationary portion of the balancing device, called the *balancing-drum head*, or balancing sleeve, which is fixed to the pump casing.

The balancing chamber is connected either to the pump suction or to the vessel from which the pump takes its suction. Thus, the back pressure in the balancing chamber is only slightly higher than the suction pressure, the difference between the two being equal to the friction losses between this chamber and the point of return. The leakage between

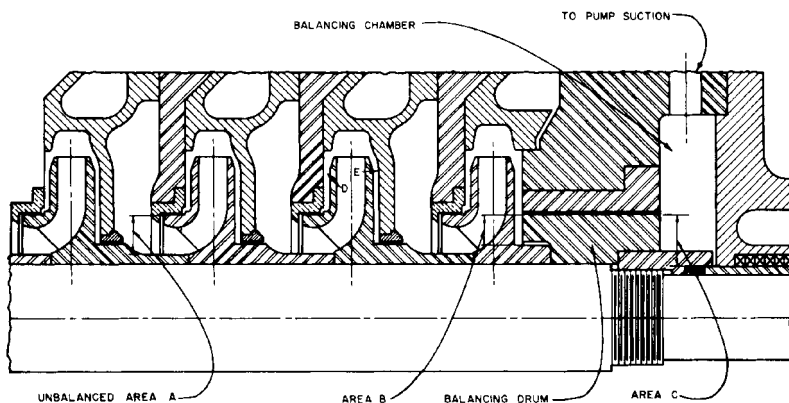


FIGURE 61 Balancing drum

the drum and the drum head is, of course, a function of the differential pressure across the drum and of the clearance area.

The forces acting on the balancing drum in Figure 61 are the following:

- *Toward the discharge end:* the discharge pressure multiplied by the front balancing area (area *B*) of the drum
- *Toward the suction end:* the back pressure in the balancing chamber multiplied by the back balancing area (area *C*) of the drum

The first force is greater than the second, thereby counterbalancing the axial thrust exerted upon the single-suction impellers. The drum diameter can be selected to balance the axial thrust completely or within 90 to 95 percent, depending on the desirability of carrying any thrust-bearing loads.

It has been assumed in the preceding simplified description that the pressure acting on the impeller walls is constant over their entire surface and that the axial thrust is equal to the product of the total net pressure generated and the unbalanced area. Actually, this pressure varies somewhat in the radial direction because of the centrifugal force exerted upon the liquid by the outer impeller shroud (refer to Figure 54). Furthermore, the pressures at two corresponding points on the opposite impeller faces (*D* and *E* in Figure 61) may not be equal because of a variation in clearance between the impeller wall and the casing section separating successive stages. Finally, a pressure distribution over the impeller wall surface may vary with head and capacity operating conditions.

This pressure distribution and design data can be determined quite accurately for any one fixed operating condition, and an effective balancing drum could be designed on the basis of the forces resulting from this pressure distribution. Unfortunately, varying head and capacity conditions change the pressure distribution, and as the area of the balancing drum is necessarily fixed, the equilibrium of the axial forces can be destroyed.

The objection to this is not primarily the amount of the thrust, but rather that the direction of the thrust cannot be predetermined because of the uncertainty about internal pressures. Still it is advisable to predetermine normal thrust direction, as this can influence external mechanical thrust-bearing design. Because 100 percent balance is unattainable in practice and because the slight but predictable unbalance can be carried on a thrust bearing, the balancing drum is often designed to balance only 90 to 95 percent of the total impeller thrust.

The balancing drum satisfactorily balances the axial thrust of single-suction impellers and reduces pressure on the discharge-side stuffing box. It lacks, however, the virtue of automatic compensation for any changes in axial thrust caused by varying impeller reaction characteristics. In effect, if the axial thrust and balancing drum forces become unequal, the rotating element will tend to move in the direction of the greater force. The thrust bearing must then prevent excessive movement of the rotating element. The balancing drum performs no restoring function until such time as the drum force again equals the axial thrust. This automatic compensation is the major feature that differentiates the balancing disk from the balancing drum.

**Balancing Disks** The operation of the simple balancing disk is illustrated in Figure 62. The disk is fixed to and rotates with the shaft. It is separated by a small axial clearance from the balancing disk head, or balancing sleeve, which is fixed to the casing. The leakage through this clearance flows into the balancing chamber and from there either to the pump suction or to the vessel from which the pump takes its suction. The back of the balancing disk is subject to the balancing chamber back pressure, whereas the disk face experiences a range of pressures. These vary from discharge pressure at its smallest diameter to back pressure at its periphery. The inner and outer disk diameters are chosen so that the difference between the total force acting on the disk face and that acting on its back will balance the impeller axial thrust.

If the axial thrust of the impellers should exceed the thrust acting on the disk during operation, the latter is moved toward the disk head, reducing the axial clearance between

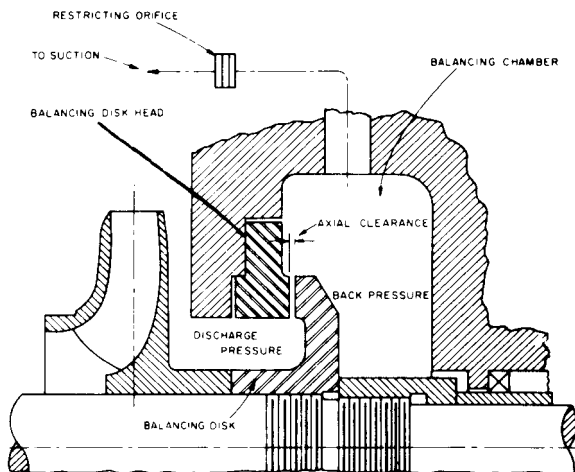


FIGURE 62 A simple balancing disk

the disk and the disk head. The amount of leakage through the clearance is reduced so that the friction losses in the leakage return line are also reduced, lowering the back pressure in the balancing chamber. This lowering of pressure automatically increases the pressure difference acting on the disk and moves it away from the disk head, increasing the clearance. Now the pressure builds up in the balancing chamber, and the disk is again moved toward the disk head until an equilibrium is reached.

To assure proper balancing in disk operation, the change in back pressure in the balancing chamber must be of an appreciable magnitude. Thus, with the balancing disk wide open with respect to the disk head, the back pressure must be substantially higher than the suction pressure to give a resultant force that restores the normal disk position. This can be accomplished by introducing a restricting orifice in the leakage return line that increases back pressure when leakage past the disk increases beyond normal. The disadvantage of this arrangement is that the pressure on the seal chamber is variable, a condition that may be injurious to the life of the seal and therefore should be avoided.

**Combination Balancing Disk and Drum** For the reasons just described, the simple balancing disk is seldom used. The combination balancing disk and drum (see Figure 63) was developed to obviate the shortcomings of the disk while retaining the advantage of automatic compensation for axial thrust changes.

The rotating portion of this balancing device consists of a long cylindrical body that turns within a drum portion of the disk head. This rotating part incorporates a disk similar to the one previously described. In this design, radial clearance remains constant regardless of disk position, whereas the axial clearance varies with the pump rotor position. The following forces act on this device:

- *Toward the discharge end:* the sum of the discharge pressure multiplied by area  $A$ , plus the average intermediate pressure multiplied by area  $B$
- *Toward the suction end:* the back pressure multiplied by area  $C$

Whereas the position-restoring feature of the simple balancing disk required an undesirably wide variation of the back pressure, it is now possible to depend upon a variation of the intermediate pressure to achieve the same effect. Here is how it works: When the pump rotor moves toward the suction end (to the left in Figure 63) because of increased axial thrust, the axial clearance is reduced and pressure builds up in the intermediate

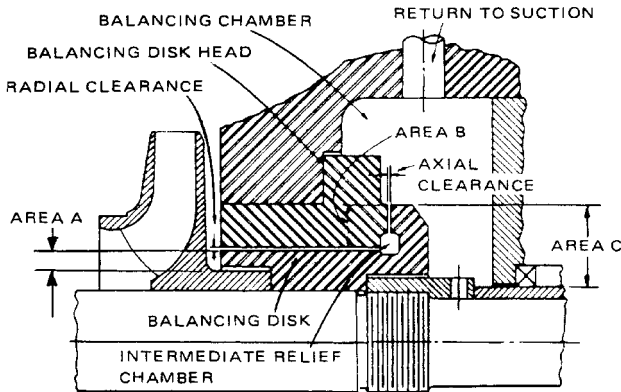


FIGURE 63 A combination balancing disk and drum

relief chamber, increasing the average value of the intermediate pressure acting on area *B*. In other words, with reduced leakage, the pressure drop across the radial clearance decreases, increasing the pressure drop across the axial clearance. The increase in intermediate pressure forces the balancing disk toward the discharge end until equilibrium is reached. Movement of the pump rotor toward the discharge end would have the opposite effect, increasing the axial clearance and the leakage and decreasing the intermediate pressure acting on area *B*.

Now numerous hydraulic balancing device modifications are in use. One typical design separates the drum portion of a combination device into two halves, one preceding and the second following the disk (see Figure 64). The virtue of this arrangement is a definite cushioning effect at the intermediate relief chamber, thus avoiding too positive a restoring action, which might result in the contacting and scoring of the disk faces.

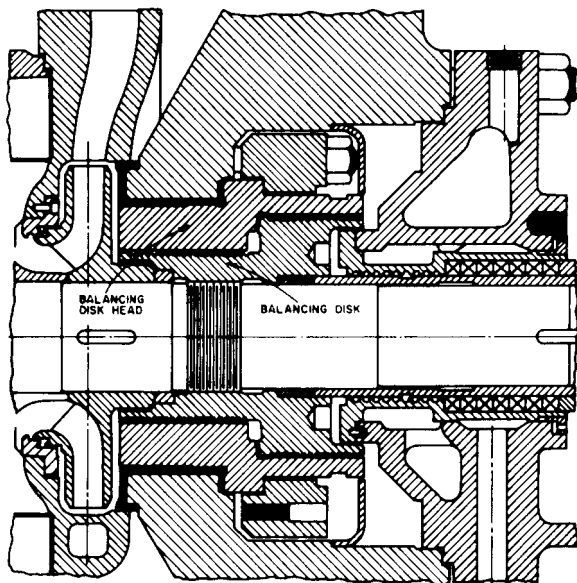
## SHAFTS AND SHAFT SLEEVES

The basic function of a centrifugal pump shaft is to transmit the torques encountered when starting and during operation while supporting the impeller and other rotating parts. It must do this job with a deflection less than the minimum clearance between rotating and stationary parts. The loads involved are (1) the torques, (2) the weight of the parts, and (3) both radial and axial hydraulic forces. In designing a shaft, the maximum allowable deflection, the span or overhang, and the location of the loads all have to be considered, as does the critical speed of the resulting design.

Shafts are usually proportioned to withstand the stress set up when a pump is started quickly, such as when the driving motor is energized directly across the line. If the pump handles hot liquids, the shaft is designed to withstand the stress set up when the unit is started cold without any preliminary warmup.

**Critical Speeds** Any object made of an elastic material has a natural period of vibration. When a pump rotor or shaft rotates at any speed corresponding to its natural frequency, minor unbalances will be magnified. These speeds are called the *critical speeds*.

In conventional pump designs, the rotating assembly is theoretically uniform around the shaft axis and the center of mass should coincide with the axis of rotation. This theory does not hold for two reasons. First, minor machining or casting irregularities always occur. Second, variations exist in the metal density of each part. Thus, even in vertical-shaft machines having no radial deflection caused by the weight of the parts, this eccentricity of the center of mass produces a centrifugal force and therefore a deflection when



**FIGURE 64** A combination balancing disk and drum with a disk located in the center portion of the drum (Flowsolve Corporation)

the assembly rotates. At the speed where the centrifugal force exceeds the elastic restoring force, the rotor will vibrate as though it were seriously unbalanced. If it is run at that speed without restraining forces, the deflection will increase until the shaft fails.

**Rigid and Flexible Shaft Designs** The lowest critical speed is called the first critical speed, the next highest is called the second, and so forth. In centrifugal pump nomenclature, a *rigid shaft* means one with an operating speed lower than its first critical speed. A *flexible shaft* is one with an operating speed higher than its first critical speed. Once an operating speed has been selected, relative shaft dimensions must still be determined. In other words, it must be decided whether the pump will operate above or below the first critical speed.

Actually, the shaft critical speed can be reached and passed without danger because frictional forces tend to restrain the deflection. These forces are exerted by the surrounding liquid, and the various internal leakage joints acting as internal liquid-lubricated bearings. Once the critical speed is passed, the pump will run smoothly again up to the second speed corresponding to the natural rotor frequency, and so on to the third, fourth, and all higher critical speeds.

Designs rated for 1,750 rpm (or lower) are usually of the rigid-shaft type. On the other hand, high-head 3,600 rpm (or higher) multistage pumps, such as those in a boiler-feed service, are frequently of the flexible-shaft type. It is possible to operate centrifugal pumps above their critical speeds for the following two reasons: (1) very little time is required to attain full speed from rest (the time required to pass through the critical speed must therefore be extremely short) and (2) the pumped liquid in the internal leakage joints acts as a restraining force on the vibration.

Experience has proved that, although it was usually assumed necessary to use shafts of such rigidity that the first critical speed is at least 20 percent above the operating speed, equally satisfactory results can be obtained with lighter shafts with a first critical speed of about 60 to 75 percent of the operating speed. This, it is felt, is a sufficient margin to avoid any danger caused by an operation close to the critical speed.

**Influence of Shaft Deflection** To understand the effect of critical speed on the selection of shaft size, consider the fact that the first critical speed of a shaft is linked to its static deflection. Shaft deflection depends upon the weight of the rotating element ( $w$ ), the shaft span ( $l$ ), and the shaft diameter ( $d$ ). The basic formula is as follows:

$$f = \frac{wl^3}{CEI}$$

where  $f$  = deflection, in (m)

$w$  = weight of the rotating element, lb (N)

$l$  = shaft span, in (m)

$C$  = coefficient depending on shaft-support method and load distribution

$E$  = modulus of elasticity of shaft materials, lb/in<sup>2</sup> (N/m<sup>2</sup>)

$I$  = moment of inertia ( $\pi d^4/64$ ) in<sup>4</sup> (m<sup>4</sup>)

This formula is given in its most simplified form, that is, for a shaft of constant diameter. If the shaft is of varying diameter (the usual situation), deflection calculations are much more complex. A graphical deflection analysis may then be the most practical answer.

This formula works only for static deflection, the only variable that affects critical speed calculations. The actual shaft deflection, which must be determined to establish minimum permissible internal clearances, must take into account all transverse hydraulic reactions on the rotor, the weights of the rotating element, and other external loads.

It is not necessary to calculate the exact deflection to make a relative shaft comparison. Instead, a factor can be developed that will be representative of relative shaft deflections. As a significant portion of rotor weight is in the shaft, and as methods of bearing support and the modulus of elasticity are common to similar designs, deflection  $f$  can be shown as follows:

$$f = \text{function of } \frac{(ld^2)(l^3)}{d^4}$$

$$f = \text{function of } \frac{l^4}{d^2}$$

In other words, pump deflection varies approximately as the fourth power of the shaft span and inversely as the square of shaft diameter. Therefore, the lower the  $l^4/d^2$  factor for a given pump, the lower the unsupported shaft deflection, essentially in proportion to this factor.

For practical purposes, the first critical speed  $N_c$  can be calculated as

$$\text{in USCS units} \quad N_c = \frac{187.7}{\sqrt{f(\text{in})}} \text{ rpm}$$

$$\text{in SI units} \quad N_c = \frac{946}{\sqrt{f(\text{mm})}} \text{ rpm}$$

To maintain internal clearances at the wearing rings, it is usually desirable to limit the shaft deflection under the most adverse conditions to between 0.005 and 0.006 in (0.127 and 0.152 mm). It follows that a shaft design with a deflection of 0.005 to 0.006 in will have a first critical speed of 2,400 to 2,650 rpm. This is the reason for using rigid shafts for pumps that operate at 1,750 rpm or lower. Multistage pumps operating at 3,600 rpm or higher use shafts of equal stiffness (for the same purpose of avoiding wearing ring contact). However, their corresponding critical speed is about 25 to 40 percent less than their operating speed.



**Lomakin Effect** All the previous material refers to the behavior of a rotor and its shaft operating in air. In reality, the rotor operates immersed in the liquid being pumped, and this liquid flows through one or more of the small annular areas created by clearances separating regions in the pump under different pressures, such as at the wearing rings, interstage bushings, or balancing devices. This flow of liquid creates what is called a *hydrodynamic bearing effect* and essentially transforms the rotor from one supported at two bearings external to the pump to one with several additional internal bearings lubricated by the liquid pumped. This phenomenon is generally called the *Lomakin effect*.

The result of the Lomakin effect is that the deflection of the shaft when a pump is running is reduced somewhat from the value calculated for the shaft operating in air and the critical speed is increased. The advantage of this effect, particularly in the design of some multistage pumps, is that it permits the use of longer and more slender shafts. Whether this is sound practice remains a controversial subject. The supportive effect of the hydrodynamic bearings depends on (a) the pressure differential, which disappears completely when the pump is at rest, and (b) the clearance, which decreases substantially as the internal clearances increase with erosive or contact wear. Thus, contact between rotating and stationary parts will take place every time a pump is started if the internal clearances are initially less than the shaft deflection in air. This contact will again take place as the pump coasts down after being stopped. Furthermore, as wear takes place at the running joints, the shaft assumes a deflection closer and closer to its deflection in air, unsupported by the Lomakin effect.

In view of all these facts, it is recommended that pump users acquaint themselves not only with the calculated shaft deflections with a pump running in new condition, but also with the shaft deflections in air. This way they can compare these with the internal clearances.

**Shaft Sizing** Shaft diameters are usually larger than what is actually needed to transmit the torque. A factor that assures this conservative design is a requirement for ease of rotor assembly.

The shaft diameter must be stepped up several times from the end of the coupling to its center to facilitate impeller mounting (see Figure 65). Starting with the maximum diameter at the impeller mounting, there is a step down for the shaft sleeve and another for the external shaft nut, followed by several more for the bearings and the coupling. Therefore, the shaft diameter at the impellers exceeds that required for torsional strength at the coupling by at least an amount sufficient to provide all intervening step downs.

One frequent exception to shaft oversizing at the impeller occurs in units consisting of two double-suction, single-stage pumps operating in a series, one of which is fitted with a

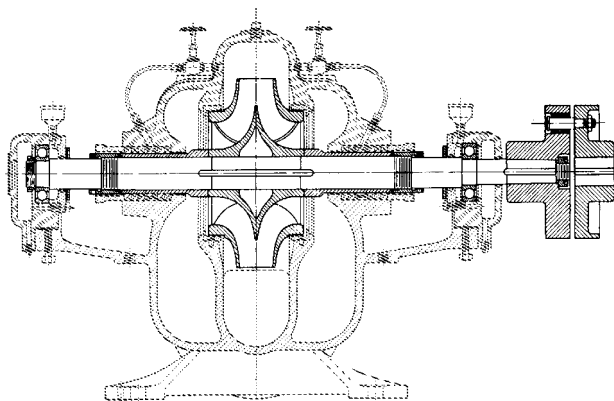


FIGURE 65 Rotor assembly of a single-stage, double-suction pump (Flowservice Corporation)



double-extended shaft. As this pump must transmit the total horsepower for the entire series unit, the shaft diameter at its inboard bearing may have to be larger than normal.

The shaft design of end-suction, overhung impeller pumps presents a somewhat different problem. One method for reducing shaft deflection at the impeller and seal chamber, where the concentricity of running fits is extremely important, is to considerably increase the shaft diameter between the bearings.

Except in certain smaller sizes, centrifugal pump shafts are protected against wear, erosion, and corrosion by renewable shaft sleeves. In small pumps, however, shaft sleeves present a certain disadvantage. As the sleeve cannot appreciably contribute to shaft strength, the shaft itself must be designed for the full maximum stress. Shaft diameter is then materially increased by the addition of the sleeve, as the sleeve thickness cannot be decreased beyond a certain safe minimum. The impeller suction area may therefore become dangerously reduced, and if the eye diameter is increased to maintain a constant eye area, the liquid pickup speed must be increased unfavorably. Other disadvantages accrue from greater hydraulic and seal losses caused by increasing the effective shaft diameter out of proportion to the pump size.

To eliminate these shortcomings, very small pumps frequently use shafts of stainless steel or some other material that is sufficiently resistant to corrosion and wear that it does not need shaft sleeves. One such pump is illustrated in Figure 66. Manufacturing costs, of course, are much less for this type of design, and the cost of replacing the shaft is about the same as the cost of new sleeves (including installation).

**Shaft Sleeves** Pump shafts are usually protected from erosion, corrosion, and wear at seal chambers, leakage joints, internal bearings, and in the waterways by renewable sleeves.

The most common shaft sleeve function is that of protecting the shaft from wear at packing and mechanical seals. Shaft sleeves serving other functions are given specific names to indicate their purpose. For example, a shaft sleeve used between two multistage pump impellers in conjunction with the interstage bushing to form an interstage leakage joint is called an *interstage* or *distance sleeve*.

In medium-size centrifugal pumps with two external bearings on opposite sides of the casing (the common double-suction and multistage varieties), the favored shaft sleeve construction uses an external shaft nut to hold the sleeve in an axial position against the impeller hub. Sleeve rotation is prevented by a key, usually an extension of the impeller key (see Figure 67). The axial thrust of the impeller is transmitted through the sleeve to the external shaft nut.

In larger high-head pumps, a high axial load on the sleeve is possible and a design similar to that shown in Figure 68 may be preferred. This design has the advantages of simplicity and ease of assembly and maintenance. It also provides space for a large seal chamber

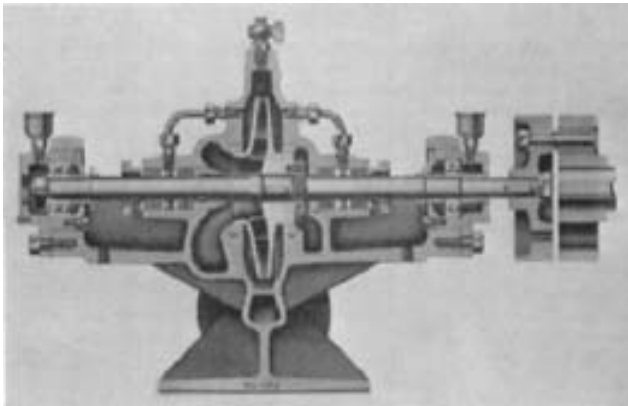


FIGURE 66 Section of a small centrifugal pump with no shaft sleeves (Flowserve Corporation)

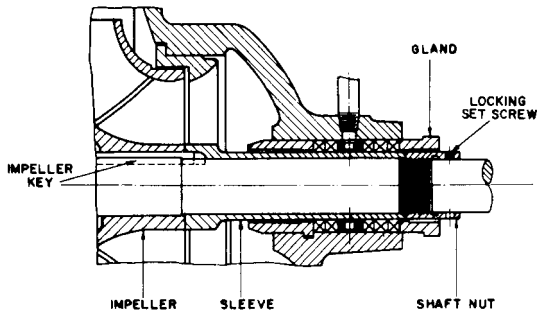


FIGURE 67 A sleeve with external locknut and impeller key extending into the sleeve to prevent rotation

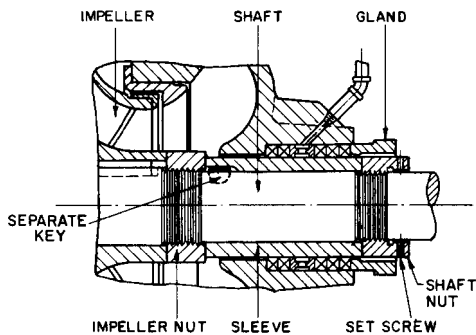


FIGURE 68 A sleeve with an internal impeller nut, external shaft-sleeve nut, and a separate key for the sleeve

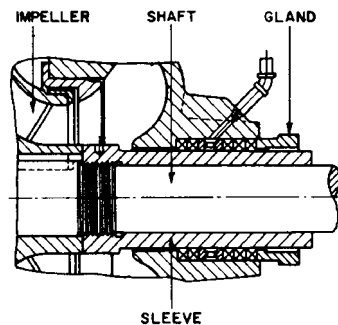


FIGURE 69 A sleeve threaded onto a shaft with no external locknut

and cartridge-type mechanical seals. When shaft sleeve nuts are used to retain the sleeves and impellers axially, they are usually manufactured with right- and left-hand threads. The friction of the pumpage and inadvertent contact with stationary parts or bushings will tend to tighten the nuts against the sleeve and impeller hub (rather than loosen them). Usually, the shaft sleeves utilize extended impeller keys to prevent rotation.

Some manufacturers favor the sleeve shown in Figure 69, in which the impeller end of the sleeve is threaded and screwed to a matching thread on the shaft. A key cannot

be used with this type of sleeve, and right- and left-hand threads are substituted so that the frictional grip of the packing on the sleeve will tighten it against the impeller hub. As a safety precaution, the external shaft nuts and the sleeve itself use set screws for a locking device.

In pumps with overhung impellers, various types of sleeves are used. Most pumps use mechanical seals, and the shaft sleeve is usually a part of the mechanical seal package supplied by the seal manufacturer. Many mechanical seals are of the cartridge design, which is set and may be bench-tested for leakage prior to installation in the pump. (For a further discussion of mechanical seals, see Subsection 2.2.3.)

For overhung impeller pumps that utilize packing for sealing, the packing sleeves generally extend from the impeller hub through the seal chambers (or stuffing boxes) to protect the pump shaft from wear (see Figure 70). The sleeves are usually keyed to the shaft to prevent rotation. If a hook-type sleeve is used, the hook part of the sleeve is clamped between the impeller and a shaft shoulder to maintain the axial position of the sleeve. A hook-type sleeve used to be popular for overhung impeller pumps that operate at high temperatures because it is clamped at the impeller end and the rest of the sleeve is free to expand axially with temperature changes. But with the increased use of cartridge-type seals, the use of hook-type sleeves is diminishing.

In designs with a metal-to-metal joint between the sleeve and the impeller hub or shaft nut, a sealing device is required between the sleeve and the shaft to prevent leakage. Pumped liquid can leak into the clearance between the shaft and the sleeve when operating under a positive suction head and air can leak into the pump when operating under a negative suction head. This seal can be accomplished by means of an *O*-ring, as shown in Figure 71, or a flat gasket. For high temperature services, the sealing device must be either acceptable for the temperature to which it will be exposed, or it must be located outside the high temperature liquid environment. An alternative design used for some high-temperature process pumps is shown in Figure 72. In this arrangement, the contact surface of the hook-type sleeve and the shaft is ground at a 45-degree angle to form a metal-to-metal seal. That end of the sleeve is locked, but the other is *free* to expand with temperature changes.

When O-rings are used, any sealing surfaces must be properly finished to ensure a positive seal is achieved. All bores and changes in diameter over which O-rings must be passed should be properly radiused and chamfered to protect against damage during assembly. Guidelines for assembly dimensions and surface finish criteria are listed in O-ring manufacturers' catalogs.

**Material for Packing Sleeves** Packing sleeves are surrounded in the stuffing box by packing. The sleeve must be smooth so that it can turn without generating too much friction and heat. Thus, the sleeve materials must be capable of taking a very fine finish, preferably a polish. Cast-iron is therefore not suitable. A hard bronze is generally used for pumps handling clear water, but chrome or other stainless steels are sometimes pre-

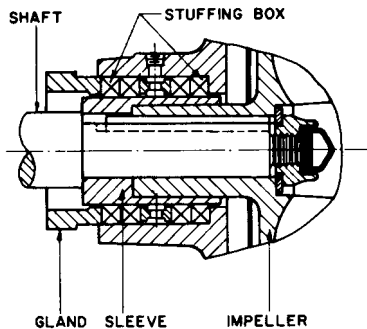


FIGURE 70 A sleeve for pumps with an overhung impeller

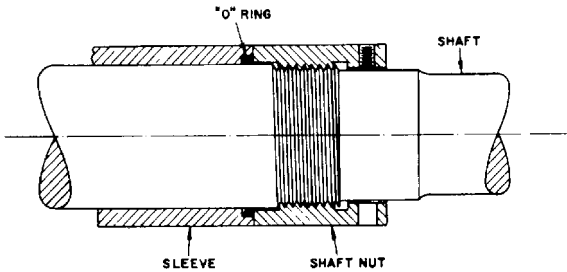


FIGURE 71 A seal arrangement for the shaft sleeve to prevent leakage along the shaft

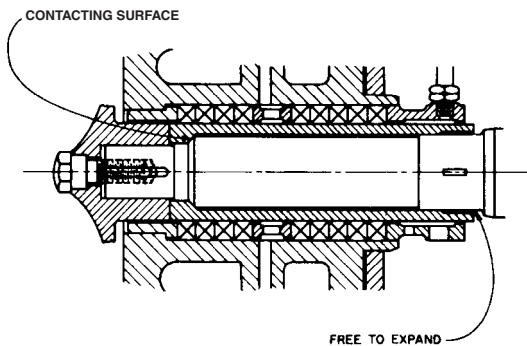


FIGURE 72 A sleeve with a 45° bevel contacting surface

ferred. For pumps subject to abrasives, hardened chrome or other stainless steels give good results. In most applications, a hardened chromium steel sleeve will be technically adequate, and the most economical choice. For severe or unusual conditions, coated sleeves are used. Ceramic coatings, applied using a plasma spray process, have also been used. Chromium oxide and aluminum oxide are the most common ceramic coatings. Both are extremely hard and resist abrasive wear well.

Ceramic coatings have been replaced in some applications by tungsten carbide coatings applied using a *high-velocity oxyfuel* (HVOF) process. The superior impact resistance and bond strength of these coatings is well documented. Another coating that is widely used on pump sleeves is a nickel-chromium-silicon-boron self-fluxing coating. This coating has a good resistance to galling and moderate resistance to abrasive wear.

Sleeves intended for coating should be machined with an undercut, so that the coating does not extend to the edge of the sleeve. This will prevent chipping at the edge, especially with the more brittle ceramic coatings.

## SEAL CHAMBERS AND STUFFING BOXES

Seal chambers have the primary function of protecting the pump against leakage at the point where the shaft passes out through the pump pressure casing. If the pump handles a suction lift and the pressure at the bottom of the seal chamber (the point closest to the inside of the pump) is below atmospheric, the seal chamber function is to prevent air leakage into the pump. If this pressure is above atmospheric, the function is to prevent liquid leakage out of the pump.

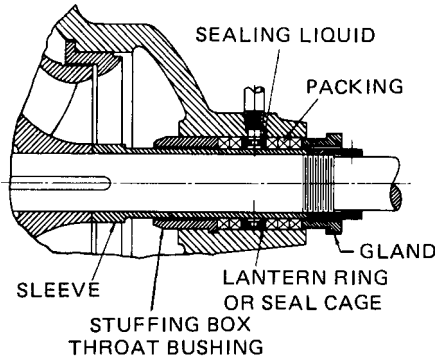


FIGURE 73 A conventional stuffing box with throat bushing

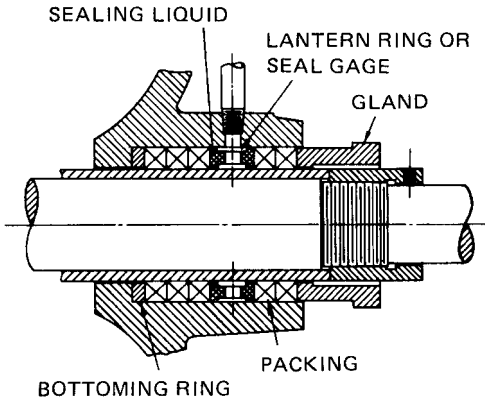


FIGURE 74 A conventional stuffing box with a bottoming ring



FIGURE 75 A lantern ring (also called a seal cage)

When sealing is accomplished by means of a mechanical seal, the seals are installed in a *seal chamber*. When sealing is accomplished by means of packing, the seal chamber is commonly referred to as a *stuffing box*. For general service pumps, a stuffing box usually takes the form of a cylindrical recess that accommodates a number of rings of packing around the shaft or shaft sleeve (see Figures 73 and 74). If sealing the box is desired, a lantern ring or seal cage (see Figure 75) is used to separate the rings of packing into approximately equal sections. The packing is compressed to give the desired fit on the

shaft or sleeve by a gland that can be adjusted in an axial direction. The bottom or inside end of the box can be formed by the pump casing (refer to Figure 70), a throat bushing (see Figure 78), or a bottoming ring (see Figure 74).

For manufacturing reasons, throat bushings are widely used on smaller pumps with axially split casings. Throat bushings are always solid rather than split. The bushing is usually held from rotation by a tongue-and-groove joint locked in the lower half of the casing.

**Packing Lantern Rings (Seal Cages)** When a pump operates with negative suction head, the inner end of the stuffing box is under vacuum and air tends to leak into the pump. For this type of service, packing is usually separated into two sections by a lantern ring or seal cage (refer to Figure 73).

Water or some other sealing fluid is introduced under pressure into the lantern ring connection, causing a flow of sealing fluid in both axial directions. This construction is useful for pumps handling chemically active or dangerous liquids since it prevents an outflow of the pumped liquid. Lantern rings are usually axially split for ease of assembly.

Some installations involve variable suction conditions, the pump operating part of the time with suction head and part of the time with suction lift. When the operating pressure inside the pump exceeds atmospheric pressure, the liquid lantern ring becomes inoperative (except for lubrication). However, it is maintained in services so that when the pump is primed at starting, all air can be excluded.

**Sealing Liquid Arrangements** When a pump handles clean, cool water, sealing liquid connections are usually to the pump discharge or, in multistage pumps, to an intermediate stage. An independent supply of sealing water should be provided if any of the following conditions exist:

- A suction lift in excess of 15 ft (4.5 m)
- A discharge pressure under 10 lb/in<sup>2</sup> (0.7 bar)
- Hot water (over 250°F or 120°C) being handled without adequate cooling (except for boiler-feed pumps, in which lantern rings are not used)
- Muddy, sandy, or gritty water being handled
- The pump is a hot-well pump.
- The liquid being handled is other than water, such as acid, juice, molasses, or sticky liquids, without special provision in the stuffing box design for the nature of the liquid

If the suction lift exceeds 15 ft (4.5 m), excessive air infiltration through the stuffing boxes may make priming difficult unless an independent seal is provided. A discharge pressure under 10 lb/in<sup>2</sup> (0.7 bar) may not provide sufficient sealing pressure. Hot-well (or condensate) pumps operate with as much as a 28-in Hg (710 mm Hg) vacuum, and air infiltration would take place when the pumps are standing idle in standby service.

When sealing water is taken from the pump discharge, an external connection may be made through small-diameter piping (see Figure 76) or internal passages. In some pumps, these connections are arranged so that a sealing liquid can be introduced into the packing space through an internal drilled passage either from the pump casing or from an external source (see Figure 77). When the liquid pumped is used for sealing, the external connection is plugged. If an external sealing liquid source is required, it is connected to the external pipe tap with a socket-head pipe plug inserted at the internal pipe tap.

It is sometimes desirable to locate the lantern ring with more packing on one side than on the other. For example, in gritty-water services, a lantern ring location closer to the inner portion of the pump would divert a greater proportion of sealing liquid into the pump, thereby keeping grit from working into the box. An arrangement with most of the packing rings between the lantern ring and the inner end of the stuffing box would be applied to reduce dilution of the pumped liquid.

Some pumps handle water in which there are small, even microscopic, solids. Using water of this kind as a sealing liquid introduces the solids into the leakage path, shortening the life of the packing and sleeves. It is sometimes possible to remove these solids

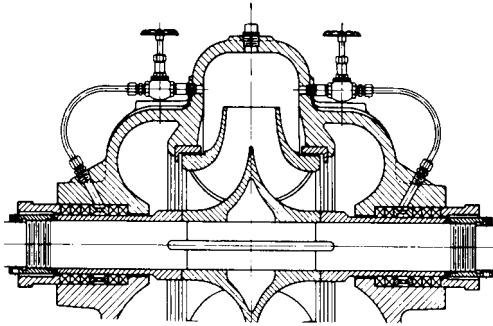


FIGURE 76 Piping connections from the pump discharge to seal cages

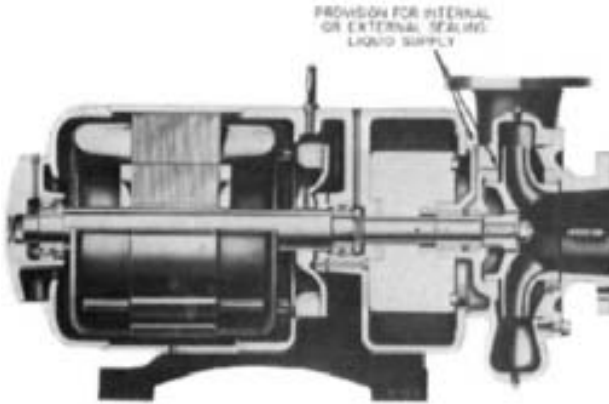


FIGURE 77 An end-suction pump with provisions for an internal or external sealing-liquid supply (Flowsolve Corporation)

by installing small pressure filters in the sealing water piping from the casing to the stuffing box.

Filters ultimately get clogged, though, unless they are frequently backwashed or otherwise cleaned out. This disadvantage can be overcome by using a cyclone (or centrifugal) separator. The operating principle of the cyclone separator is based on the fact that if a liquid under pressure is introduced tangentially into a vortexing chamber, a centrifugal force will make it rotate in the chamber, creating a vortex. Particles heavier than the liquid in which they are carried will hug the outside wall of the vortexing chamber and the liquid in the center of the chamber will be relatively free of foreign matter. The action of such a separator is illustrated in Figure 78. Liquid piped from the pump discharge or from an intermediate stage of a multistage pump is piped to inlet tap A, which is drilled tangentially to the cyclone bore. The liquid containing solids is directed downward to the apex of the cone at outlet tap B and is piped to the suction or to a low-pressure point in the system. The cleaned liquid is taken off at the center of the cyclone at outlet tap C and is piped to the stuffing box.

Sand that will pass through a No. 40 sieve will be completely eliminated in a cyclone separator with supply pressures as low as 20 lb/in<sup>2</sup> (1.4 bar). With 100 lb/in<sup>2</sup> (7-bar) supply pressure, 95 percent of the particles of 5-micron size will be eliminated.

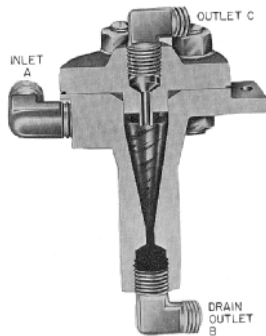


FIGURE 78 An illustration of the principle of cyclone separators (Flowsolve Corp.)

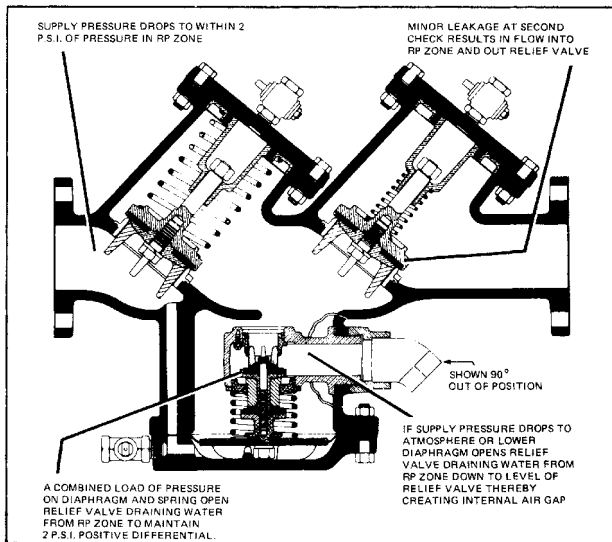


FIGURE 79 Backflow preventer (Hersey Products)

Most city ordinances require that some form of backflow preventer be interposed between city water supply lines and connections to equipment where backflow or siphoning could contaminate a drinking water supply.

This is the case, for instance, with an independent sealing supply used for stuffing boxes of sewage pumps. Quite a variety of backflow preventers are available. In most cases, the device consists of two spring-loaded check valves in a series and a spring-loaded, diaphragm-actuated, differential-pressure relief valve located in the zone between the check valves (see Figure 79).

In a normal operation, both check valves remain open as long as there is a demand for sealing water. The differential-pressure relief valve remains closed because of the pressure drop past the first check valve. If the pressure downstream of the device increases, tending to reverse the direction of the flow, both check valves close and prevent backflow. If the second check valve is prevented from closing tightly, the leakage past it increases the pressure between the two check valves, the relief valve opens, and water is discharged to the



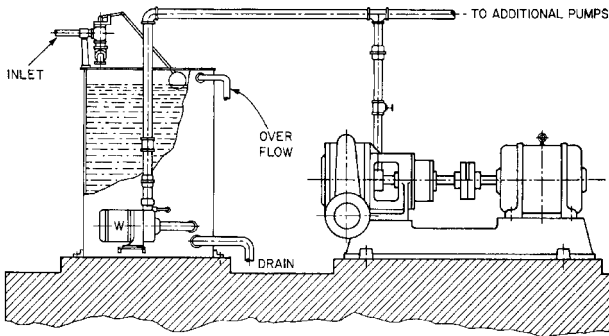


FIGURE 80 A water seal unit

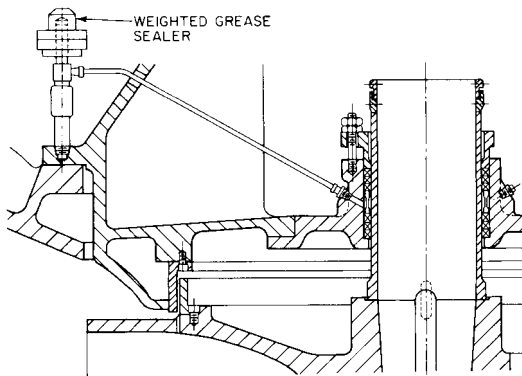


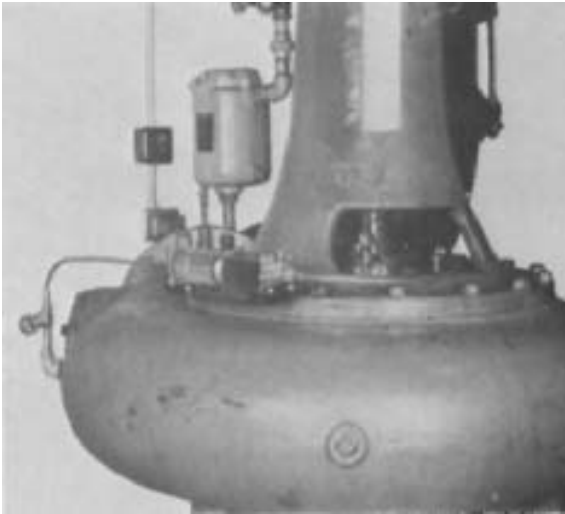
FIGURE 81 A weighted grease sealer

atmosphere. Thus, the relief valve operates automatically to maintain the pressure between the two check valves lower than the supply pressure.

Some local ordinances prohibit any connections between city water lines and a sewage or process liquid line. In such cases, an open tank under atmospheric pressure is installed into which city water can be admitted and from which a small pump can deliver the required quantity of sealing water. Such a water-sealing supply unit (see Figure 80) can be installed in a location where it can serve a number of pumps.

The tank is equipped with a float valve to feed and regulate the water level so that contamination of the city water supply is prevented. A small close-coupled pump is mounted directly on the tank and maintains a constant pressure of clear water at the stuffing box seals of the battery of pumps it serves. A small recirculation line is provided from the close-coupled pump discharge back to the tank to prevent operation at shutoff. The discharge pressure of the small supply pump is set by the maximum sealing pressure required at any of the pumps served. The supply at the individual stuffing boxes is then regulated by setting small control valves in each individual line.

If clean, cool water is not available (as with some drainage, irrigation, or sewage pumps), grease or oil seals are often used. Most pumps for sewage service have a single stuffing box subject to discharge pressure that operates with a flooded suction. It is therefore not necessary to seal these pumps against air leakage, but forcing grease or oil into the sealing space at the packing helps to exclude grit. Figure 81 shows a typical weighted grease sealer.



**FIGURE 82** An automatic grease sealer mounted on a vertical pump (Zimmer & Francescon)

Automatic grease or oil sealers that exert pump discharge pressure in a cylinder on one side of a plunger, with light grease or oil on the other side, are available for sewage service. The oil or grease line is connected to the stuffing box seal, which is at about 80 percent of the discharge pressure. As a result, there is a slow flow of grease or oil into the pump when the unit is in operation. No flow takes place when the pump is out of service. Figure 82 shows an automatic grease sealer mounted on a vertical sewage pump.

**Water-Cooled Stuffing Boxes** High temperatures or pressures complicate the problem of maintaining stuffing box packing. Pumps in these more difficult services are usually provided with mechanical seals and seal support systems. When it is necessary or desirable to use packing, however, the pumps are usually equipped with jacketed, water-cooled stuffing boxes. The cooling water removes heat from the liquid leaking through the stuffing box and heat generated by friction in the box, thus improving packing service conditions. In some special cases, liquid other than water can be used in the cooling jackets. Two water-cooled stuffing box designs are commonly used. The first, shown in Figure 83, provides cored passes in the casing casting. These passages that surround the stuffing box are arranged with in-and-out connections. The second type uses a separate cooling chamber combined with the stuffing box proper, with the whole assembly inserted into and bolted to the pump casing (see Figure 84). The choice between the two is based on manufacturing preferences.

Caution is required when depending on water cooling to provide proper operation because of the danger of passage fouling and a loss of cooling effectiveness during operation. It is important that any such cooling passages be accessible for periodic inspection and cleaning to ensure that effective cooling is maintained.

Stuffing box pressure and temperature limitations vary with the pump type because it is generally not economical to use expensive stuffing box construction for infrequent high-temperature or high-pressure applications. Therefore, whenever the manufacturer's stuffing box limitations for a given pump are exceeded, the application of pressure-reducing devices ahead of the stuffing box is recommended.

**Pressure-Reducing Devices** Essentially, pressure-reducing devices consist of a bushing or meshing labyrinth ending in a relief chamber located between the pump interior and the stuffing box or seal chamber. The relief chamber is connected to some suitable

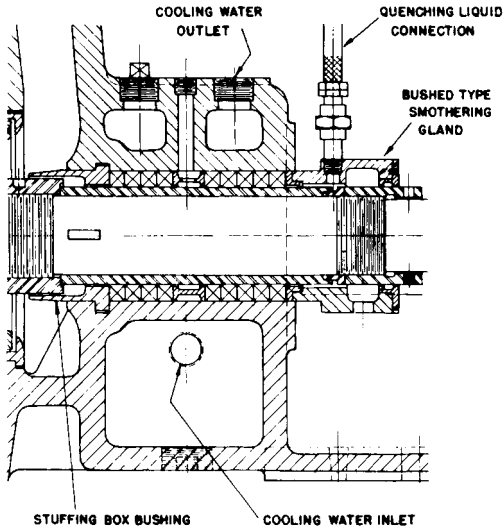


FIGURE 83 A water-cooled stuffing box with a cored water passage cast in casing

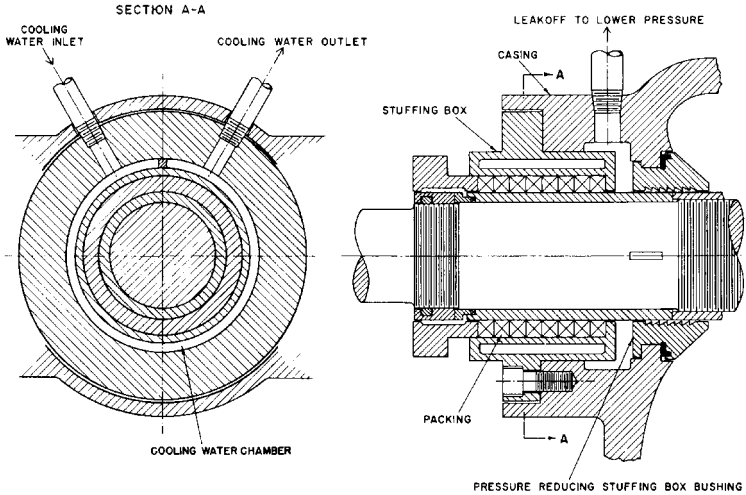


FIGURE 84 A separate water-cooled stuffing box with pressure-reducing stuffing box bushing

low-pressure point in the installation, and the leakage past the pressure-reducing device is returned to this point. If the pumped liquid must be salvaged, as with treated feedwater, it is returned to the pumping cycle. If the liquid is expendable, the relief chamber can be connected to a drain.

Many different pressure-reducing device designs exist. Figure 84 illustrates a design for limited pressures. A short serrated bushing is inserted at the bottom of the stuffing box or seal chamber, followed by a relief chamber. The leakage past the serrated bushing is bled off to a low-pressure point.

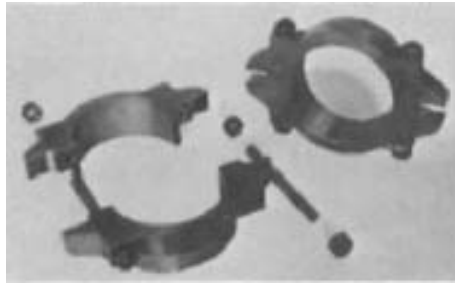


FIGURE 85 Split stuffing box gland

With relatively high-pressure units, intermeshing labyrinths can be located following the balancing device and ahead of the stuffing box or seal chamber. Piping from the chamber following pressure-reducing devices should be amply sized so that as wear increases leakage, piping friction will not increase seal chamber pressure.

**Stuffing Box Packing Glands** Stuffing box packing glands may assume several forms, but basically they can be classified into two groups: solid glands and split glands (see Figure 85). Split glands are made in halves so that they can be removed from the shaft without dismantling the pump, thus providing more working space when the stuffing boxes are being repacked. Split glands are desirable for pumps that have to be repacked frequently, especially if the space between the box and the bearing is restricted. The two halves are generally held together by bolts, although other methods are also used. Split glands are generally a construction refinement rather than a necessity, and they are rarely used in smaller pumps. They are commonly furnished for large single-stage pumps, for some multistage pumps, and for certain refinery pumps.

Another common refinement is the use of swing bolts in stuffing box packing glands. Such bolts may be swung to the side, out of the way, when the stuffing box is being repacked.

Stuffing box leakage into the atmosphere might, in some services, seriously inconvenience or even endanger the operating personnel. An example would be when volatile liquids are being pumped at vaporizing temperatures or temperatures above their flash point. As this leakage cannot always be cooled sufficiently by a water-cooled stuffing box, smothering glands are used (refer to Figure 83). Provisions are made in the gland to introduce a liquid, either water or another compatible liquid at a low temperature, that mixes intimately with the leakage, lowering its temperature or, if the liquid is volatile, absorbing it.

Stuffing box packing glands are usually made of bronze, although cast-iron or steel may be used for all iron-fitted pumps. Iron or steel glands are generally bushed with a non-sparking material like bronze in hazardous process services to prevent the ignition of flammable vapors by the glands sparking against a ferrous metal shaft or sleeve.

**Stuffing Box Packing** See Subsection 2.2.2.

## MECHANICAL SEALS VERSUS PACKING

---

Sealing with a packed stuffing box is impractical for many conditions of service. In an ordinary packed stuffing box, the sealing between the rotating shaft or shaft sleeve and the stationary portion of the stuffing box (or seal chamber) is accomplished by means of rings of packing forced between the two surfaces and held tightly in place by a packing gland. The leakage around the shaft is controlled by merely tightening or loosening the packing gland nuts (or bolts). The actual sealing surfaces consist of the axial rotating surface of the shaft or shaft sleeve and the stationary packing. Attempts to reduce or eliminate all leakage from a conventional packed stuffing box increase the compressive load of the packing

gland on the packing. The packing, being semiplastic, forms more closely to the shaft or shaft sleeve and tends to reduce the leakage. After a certain point, however, the leakage between the packing and the rotating shaft or shaft sleeve becomes inadequate to carry away the heat generated by the packing rubbing on the rotating surface, and the packing fails to function. This failure can result in burned packing, packing “blow out,” and severely damaged shaft or shaft sleeve surfaces. If the sealing surface is coated, this coating may be destroyed. Even before this condition is reached, the shaft or shaft sleeve may be severely worn and scored by the packing, so that it becomes impossible to pack the stuffing box satisfactorily.

These undesirable characteristics prohibit the use of packing as a sealing method if some leakage of the pumpage to the atmosphere is not acceptable. Packing is limited in its application pressure and temperature range (see Section 2.2.2), and it is usually not acceptable for any flammable or hazardous pumping services. To address these limitations, the mechanical seal was developed (see Section 2.2.3). The mechanical seal has found general acceptance in nearly all pumping applications. Packing is still used in certain low-pressure, low-temperature applications where leakage of the pumpage is not a problem and a history of satisfactory, economical service exists.

Mechanical seals are not always the solution to every sealing situation. Seals are still subject to failure, and their failure may be more rapid and abrupt than that of packing. If packing fails, the pump can many times be kept running by temporary adjustments until it is convenient to shut it down. If a mechanical seal fails, most often the pump must be shut down immediately. As both packed stuffing boxes and conventional mechanical face seals are subject to wear, both are subject to failure. Whether one or the other should be used depends on the specific application and the experience of the user. In some cases, both give good service and the choice becomes a matter of personal preference or cost. Table 2

**TABLE 2** Comparison of packing and mechanical seals

Advantages	Disadvantages
<b>Packing</b>	
<ol style="list-style-type: none"> <li>1. Lower initial cost</li> <li>2. Easily installed as rings and glands are split</li> <li>3. Good reliability to medium pressures and shaft speeds</li> <li>4. Can handle large axial movements (thermal expansion of stuffing box versus shaft)</li> <li>5. Can be used in rotating or reciprocating applications</li> <li>6. Leakage tends to increase gradually, giving warning of impending breakdown</li> </ol>	<ol style="list-style-type: none"> <li>1. Relatively high leakage</li> <li>2. Requires regular maintenance</li> <li>3. Wear of shaft of shaft sleeve can be relatively high</li> <li>4. Power losses may be high</li> </ol>
<b>Mechanical seals</b>	
<ol style="list-style-type: none"> <li>1. Very low leakage/no leakage</li> <li>2. Require no maintenance</li> <li>3. Eliminate sleeve wear/shaft wear</li> <li>4. Very good reliability</li> <li>5. Can handle higher pressures and speeds</li> <li>6. Easily applied to carcinogenic, toxic, flammable, or radioactive liquids</li> <li>7. Low power loss</li> </ol>	<ol style="list-style-type: none"> <li>1. Higher initial cost</li> <li>2. Easily installed but may require some disassembly of pump (couplings and so on)</li> </ol>

Source: John Crane Inc.

adds other comments and summarizes some advantages and disadvantages of packing and mechanical seals.

**Principles and Construction of Mechanical Seals** See Subsection 2.2.3.

**Injection-Type Shaft Seals** See Subsection 2.2.4.

## BEARINGS

---

The function of bearings in centrifugal pumps is to keep the shaft or rotor in correct alignment with the stationary parts under the action of radial and transverse loads. Bearings that give radial positioning to the rotor are known as radial or *line bearings*, and those that locate the rotor axially are called *thrust bearings*. In most applications, the thrust bearings actually serve both as thrust and radial bearings.

**Types of Bearings Used** All types of bearings have been used in centrifugal pumps. Even the same basic design of pump is often made with two or more different bearings, required either by varying service conditions or by the preference of the purchaser. In most pumps, however, either rolling element or oil film (sleeve-type) bearings are used today.

In horizontal pumps with bearings on each end, the bearings are usually designated by their location as *inboard*, or drive end, and *outboard*, or non-drive end. Inboard (drive end) bearings are located between the casing and the coupling. Pumps with overhung impellers have both bearings on the same side of the casing so that the bearing nearest the impeller is called inboard and the one farthest away outboard. In a pump provided with bearings at both ends, the thrust bearing is usually placed at the outboard end and the line bearing at the inboard end.

The bearings are mounted in a housing that is usually supported by brackets attached or integral to the pump casing. The housing also serves the function of containing the lubricant necessary for proper operation of the bearing. Occasionally, the bearings of very large pumps are supported in housings that form the top of pedestals mounted on sole-plates or on the pump bedplate. These are called *pedestal bearings*.

Because of the heat generated by the bearing or the heat in the liquid being pumped, some means other than radiation to the surrounding air must occasionally be used to keep the bearing temperature within proper limits. If the bearings have a force-fed lubrication system, cooling is usually accomplished by circulating the oil through a separate water-to-oil or air-to-oil cooler. Otherwise, a jacket through which a cooling liquid is circulated is usually incorporated as part of the housing.

Pump bearings may be rigid or self-aligning. A self-aligning bearing will automatically adjust itself to a change in the angular position of the shaft. In babbitted or sleeve bearings, the name *self-aligning* is applied to bearings that have a spherical fit of the sleeve in the housing. In rolling element bearings, the name is applied to bearings, the outer race of which is spherically ground or the housing of which provides a spherical fit.

Although double-suction pumps are theoretically in hydraulic balance, this balance is rarely realized in practice, and so even these pumps are provided with thrust bearings. A centrifugal pump, being a product of the foundry, is subject to minor irregularities that may cause differences in the eddy currents set up on the two sides of the impeller. As this disturbance can create an axial hydraulic thrust, some form of thrust bearing that is capable of taking a thrust in either direction is necessary to maintain the rotor in its proper position.

The thrust capacity of the bearing of a double-suction pump is usually far in excess of the probable imbalance caused by irregularities. This provision is made because (1) unequal wear of the rings and other parts may cause an imbalance and (2) the flow of the liquid into the two suction eyes may be unequal and cause an imbalance because of an improper suction-piping arrangement.

**Rolling Element Bearings** The most common rolling element bearings used on centrifugal pumps are the various types of ball bearings. Roller bearings are used less often, although the spherical roller bearing (see Figure 86) is used frequently for large shaft



FIGURE 86 Self-aligning spherical roller bearing (SKF USA, Inc.)

sizes, for which there is a limited choice of ball bearings. As most roller bearings are suitable only for radial loads, their use on centrifugal pumps tends to be limited to applications in which they are not required to carry a combined radial and thrust load.

**Ball Bearings** As the coefficient of rolling friction is less than that of sliding friction, one must not consider a ball bearing in the same light as a sleeve bearing. In the former, the load is carried on a point contact of the ball with the race, but the point of contact does not rub or slide over the race and no appreciable heat is generated. Furthermore, the point of contact is constantly changing as the ball rolls in the race, and the operation is practically frictionless. In the sleeve bearing, a constant rubbing of one surface over another occurs, and the friction must be reduced by the use of a lubricant.

Ball bearings that operate at an absolutely constant speed theoretically require no lubricant. No speed can be called absolutely constant, however, for the conditions affecting the speed always vary slightly. For instance, a motor with a full-load speed rated at 3,510 rpm might vary in speed over the course of a minute from 3,505 to 3,515 rpm. Each variation in speed causes the balls in a ball bearing to lag or lead the race because of their inertia. Consequently, a very slight, almost immeasurable sliding action takes place. Another limiting condition is that the hardest of metals suffers minute deformations on carrying loads, thus upsetting perfect point contacts and adding another slight sliding action. For these reasons, ball bearings must be given some lubrication.

Ball thrust bearings are built to carry heavy loads by pure rolling motion on an angular contact. As a thrust load is axial, it is equally distributed to all the balls around the race, and the individual load on each ball is only a small fraction of the total thrust load. In such bearings, it is essential that the balls be equally spaced, and for this purpose, a retaining cage is used between the balls and between the inner and outer races. This cage carries no load, but the contact between it and the ball produces sliding friction that requires lubrication.

**Types and Applications** Pump designers have a wide variety of rolling element bearings and arrangements to choose from. Ball bearings with their high-speed capabilities and low friction make them ideal for small and medium-size pumps, while roller bearings are more common in larger, slower speed pumps where a heavy capacity is required. Depending upon the specific bearing type, optional characteristics such as seals, shields, various cage materials and designs, and special internal clearances and preloads are available. Although several might be dimensionally acceptable, it is best for users to adhere to manufacturer recommendations to ensure optimum reliability.

The most common ball bearings used in centrifugal pumps are 1) single-row, deep-groove, 2) single-row, angular contact, and 3) double-row, angular contact ball bearings.

Sealed ball bearings are used in special applications such as vertical in-line pumps. Sealed prelubricated bearings require special attention if the unit in which they are





**FIGURE 87** Self-aligning ball bearing (SKF USA, Inc.)



**FIGURE 88** Single-row, deep-groove ball bearing (SKF USA, Inc.)

installed is not operated for long periods of time (such as stand-by units or units kept in stock or storage). The shaft should be rotated occasionally (see specific instruction manual directions) to agitate the lubricant and maintain a film coating on the bearing elements.

Self-aligning ball bearings (see Figure 87) are sometimes used for heavy loads, high speeds, long-bearing spans (large deflection angles at the bearings) and no axial thrust requirements. This bearing design acts as a pivot that compensates for misalignment and shaft deflection. For large shafts, the self-aligning spherical roller bearing (refer to Figure 86) is used instead of the self-aligning ball bearing, and it can carry both radial loads and axial thrust loads.

The single-row, deep-groove ball bearing (see Figure 88), sometimes referred to as a Conrad-type bearing, is the most commonly used bearing in centrifugal pumps, except for the larger size pumps. The Conrad-type design is recommended for use in centrifugal pumps because it can support either radial, axial, or a combination of radial and axial loads. This makes it ideal for the radial bearing in end-suction centrifugal pumps or as both the radial and thrust bearings in small pumps. The bearing design requires a careful alignment between the shaft and the housing. It is often used with seals or shields in grease-lubricated applications to help exclude dirt and retain lubricants within the bearing.

Angular contact ball bearings are commonly used in centrifugal pump applications to support axial loads or a combination of both axial and radial loads. Their axial stiffness and small operating clearances provide precise position accuracy for the shaft. Angular contact bearings are manufactured in a single-row design (see Figure 89), typically with a 40° contact angle, and also as a double-row bearing (see Figure 90), most commonly with a 30° contact angle.

Single-row, angular contact ball bearings support axial loads in only one direction when used singly. To support reversing axial loads or combined loads, single-row bearings must be mounted in a back-to-back or face-to-face arrangement where the contact angles oppose each other. Owing to its more rigid design, the back-to-back arrangement is generally recommended for centrifugal pumps, while the face-to-face arrangement is common when a slight misalignment is expected. When required to support heavy axial loads, single-row, angular contact ball bearings can be mounted in tandem where their contact angles are in the same direction. This arrangement must still be opposed with a third bearing in a back-to-back or face-to-face arrangement with the tandem pair when radial or reversing thrust loads must also be supported (see Figure 91). Depending upon the operating conditions of the pump, single-row, angular contact ball bearings typically operate with either a small clearance or a light preload.

Some applications exist where a high axial load occurs predominantly in one direction, but the thrust bearing must be capable of carrying occasional smaller axial loads in the

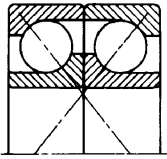




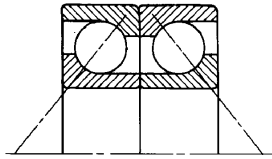
FIGURE 89 Single-row, angular contact bearing (SKF USA, Inc.)



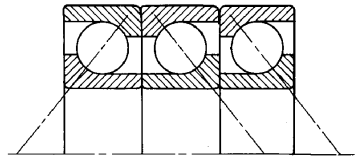
FIGURE 90 Double-row, angular contact bearing (SKF USA, Inc.)



FACE-TO-FACE



BACK-TO-BACK



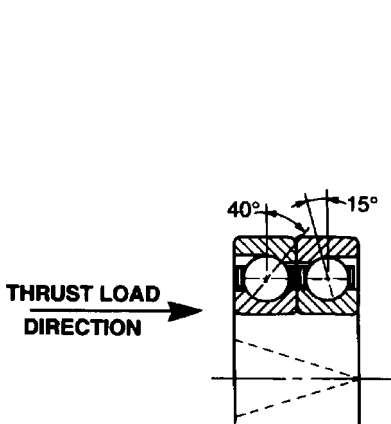
BACK-TO-BACK / TANDEM

FIGURE 91 Paired bearing arrangements (SKF USA, Inc.)

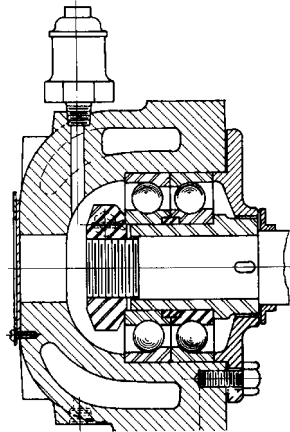
reversing direction. When this occurs, a typical back-to-back angular contact bearing arrangement can result in one bearing becoming nearly completely unloaded. In the most severe cases of axial unloading of angular contact bearings, skidding of the unloaded balls within the bearing races can occur. This skidding can result in bearing heating and subsequent damage, even failure, with time. To avoid ball skidding under light load or no-load conditions, standard angular contact bearing sets can be arranged for a light preload that will result in a sufficient load on the dynamically unloaded bearing to prevent skidding. Another alternative is to install a matched set of two angular contact bearings with different contact angles (see Figure 92). By utilizing an angular contact bearing with a lower contact angle (say 15 degrees instead of the normal 40 degrees), the unloaded bearing will have a lower requirement for an axial load and be more resistant to ball skidding. This means the bearing will run at a lower temperature.

The double-row, angular contact ball bearing (see Figure 93) is similar in design to a back-to-back pair of single-row, angular contact ball bearings, but in a narrower width package. Its ease of mounting, along with its low-friction operation, high-speed capability, and seal or shield availability, make it an ideal bearing for light- to medium-duty end suction centrifugal pumps and submersible pumps.

**Lubrication of Antifriction Bearing** In the layout of a line of centrifugal pumps, the choice of the lubricant for the pump bearings is dictated by application requirements, by cost considerations, and sometimes by the preferences of a group of purchasers committed to the major portion of the output of that line. For example, in vertical wet-pit condenser circulating pumps, water is the lubricant of choice, in preference to grease or oil. If oil or grease is used in such pumps and the lubricant leaks into the pumping system, the condenser operation might be seriously affected because the tubes would become coated with the lubricant.



**FIGURE 92** Angular contact bearings with different contact angles (SKA USA, Inc.)



**FIGURE 93** A double-row, angular-contact ball thrust bearing that is grease-lubricated and water-cooled

Most centrifugal pumps for refinery services are supplied with oil-lubricated bearings because of the insistence of refinery engineers on this feature. In the marine field, on the other hand, the preference lies with grease-lubricated bearings. For high pump operating speeds (5,000 rpm and above), oil lubrication is found to be the most satisfactory. For highly competitive lines of small pumps, the main consideration is cost, and so the most economical lubricant is chosen, depending upon the type of bearing used.

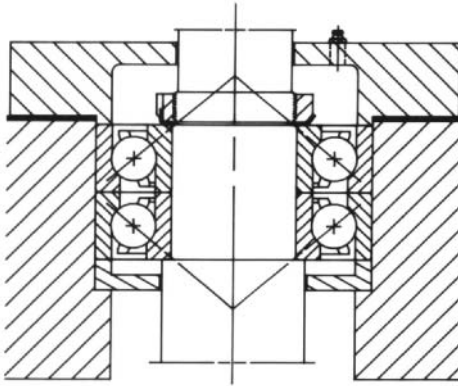
Ball bearings used in small centrifugal pumps are usually grease-lubricated, although some services use oil lubrication. In grease-lubricated bearings, the grease packed into the bearing is thrown out by the rotation of the balls, creating a slight suction at the inner race. (Even if the grade of grease is relatively light, it is still a semisolid and flows slowly. As heat is generated in the bearing, however, the flow of the grease is accelerated until the grease is thrown out at the outer race by the rotation.) As the expelled grease is cooled by contact with the housing and thus is attracted to the inner race, a continuous circulation of grease lubricates and cools the bearing. This method of lubrication requires a minimum amount of attention and has proved itself very satisfactory. A vertically mounted thrust bearing arranged for grease lubrication is shown in Figure 94.

A bearing fully packed with grease prevents proper grease circulation in itself and its housing. Therefore, as a general rule, it is recommended that only one-third of the void spaces in the housing be filled. An excess amount of grease will cause the bearing to heat up, and grease will flow out of the seals to relieve the situation. Unless the excess grease can escape through the seal or through the relief cock that is used on many large units, the bearing will probably fail early.

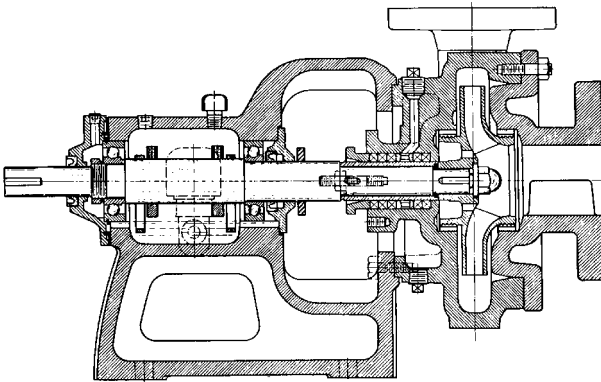
In oil-lubricated ball bearings, a suitable oil level must be maintained in the housing. This level should be at about the center of the lowermost ball of a stationary bearing. It can be achieved by a dam and an oil slinger to maintain the level behind the dam and thereby increase the leeway in the amount of oil the operator must keep in the housing. Oil rings are sometimes used to supply oil to the bearings from the bearing housing reservoir (see Figure 95). In other designs, a constant-level oiler is used (see Figure 96).

Because of the advantages of interchangeability, some pump lines are built with bearing housings that can be adapted to either oil or grease lubrication with minimum modifications (see Figure 97).

**Oil Film or Sleeve Bearings** See Subsection 2.2.5.



**FIGURE 94** Vertically mounted thrust bearing arranged for grease lubrication (SKF USA, Inc.)



**FIGURE 95** A ball bearing pump with oil rings

## **COUPLINGS**

---

Centrifugal pumps are connected to their drivers through couplings of one sort or another, except for close-coupled units, in which the impeller is mounted on an extension of the shaft of the driver.

Because couplings can be used with both centrifugal and positive displacement pumps, they are discussed separately in Section 6.3.

## **BEDPLATE AND OTHER PUMP SUPPORTS**

---

For very obvious reasons, it is desirable that pumps and their drivers be removable from their mountings. Consequently, they are usually bolted and doweled to machined surfaces that in turn are firmly connected to a foundation. To simplify the installation of horizontal-shaft units, these machined surfaces are usually part of a common bedplate on which either the pump or the pump and its driver have been prealigned.

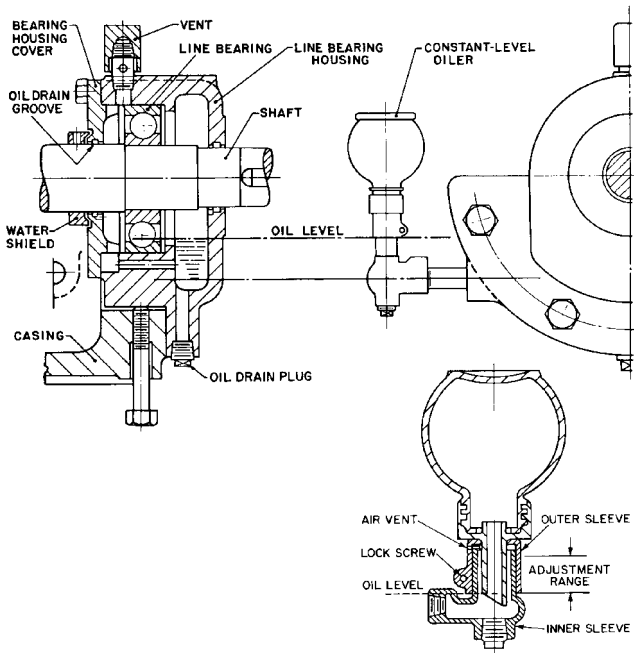


FIGURE 96 A constant-level oiler

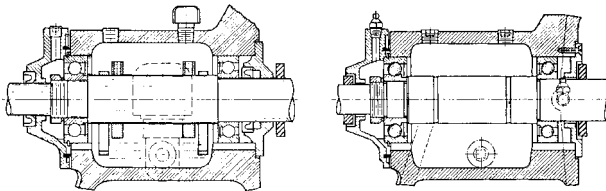
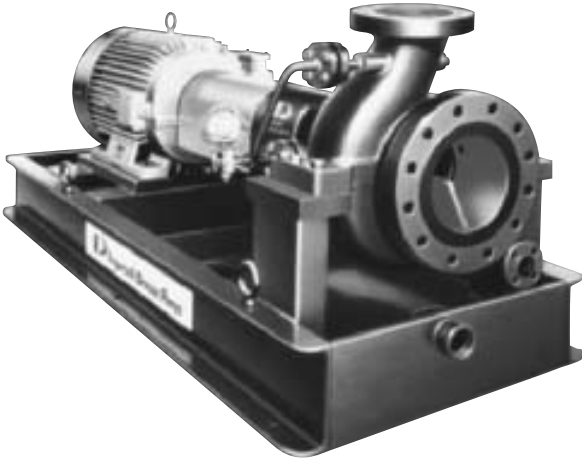


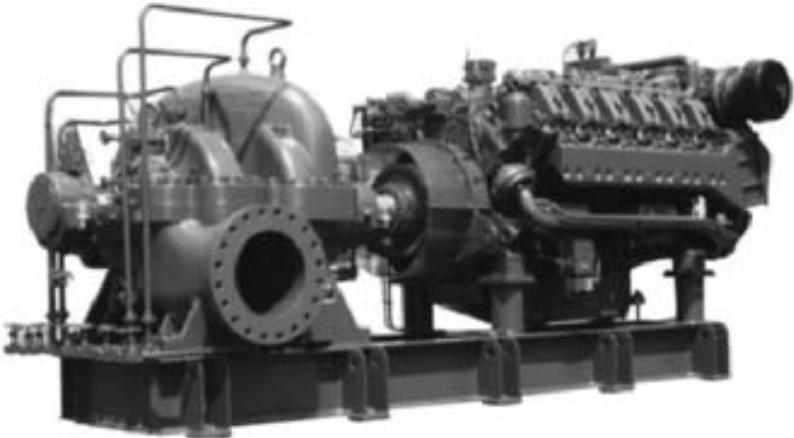
FIGURE 97 Ball bearings arranged (left) with oil rings in the housing and (right) for grease lubrication

**Bedplates** The primary function of a pump bedplate is to furnish mounting surfaces for the pump feet that can be rigidly attached to the foundation. Mounting surfaces are also necessary for the feet of the pump driver or drivers and for the feet of any independently mounted power transmission device. Although such surfaces could be provided by separate bedplates or by individually planned surfaces, it would be necessary to align these separate surfaces and fasten them to the foundation with the utmost care. Usually, this method requires in-place mounting in the field as well as drilling and tapping for the bolts after all the parts have been aligned. To minimize such field work, coupled horizontal-shaft pumps are usually purchased with a continuous base extending under the pump and its driver. Ordinarily, both these units are mounted and aligned at the place of manufacture.

Although such bases are designed to be quite rigid, they deflect if improperly supported. It is therefore necessary to support them on a foundation that can supply the required rigidity. Furthermore, as the base can be sprung out of shape by improper handling during transit, it is imperative that the alignment be carefully rechecked during erection and prior to starting the unit.



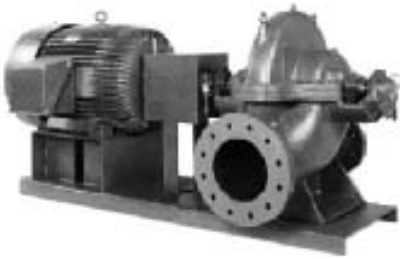
**FIGURE 98** Horizontal shaft overhung pump and driver on a structural steel bedplate with a raised edge around the base and a tapped drainage connection (Flowsolve Corporation)



**FIGURE 99** Horizontal shaft centrifugal pump and internal combustion engine mounted on a structural steel bedplate (Flowsolve Corporation)

As the unit size increases, so does the size, weight, and cost of the base required. The cost of a prealigned base for most large units exceeds the cost of the field work necessary to align individual bedplates or soleplates and to mount the component parts. Such bases are therefore used only if appearances require them or if their function as a drip collector justifies the additional cost. Even in fairly small units, the height at which the feet of the pump and the other elements are located may differ considerably. A more rigid and nice-looking installation can frequently be obtained by using individual bases or soleplates and building up the foundation to various heights under the separate portions of equipment.

Baseplates are usually provided with a raised edge or raised lip around the base to prevent dripping or draining onto the floor (see Figure 98). The base itself is sloped toward



**FIGURE 100** Horizontal shaft centrifugal pump and driver on a structural steel bedplate made of a simple channel shape (Flowserve Corporation)



**FIGURE 101** Single-stage double-suction pump with centerline support (Flowserve Corporation)

one end to collect the drainage for further disposal. A drain pocket is provided near the bottom of the slope, sometimes with a mesh screen. A tapped connection in the pocket permits piping the drainage to a convenient point.

Bedplates are usually fabricated from steel plate and structural steel shapes (see Figures 99 and 100). Even though most of these fabrications have a drain capability, because of the popular use of mechanical seals and the containment of stuffing box leakage for pumps that continue to use shaft packing (leakage is usually collected in the bearing bracket and piped to a common collecting point), the bedplate surfaces actually are seldom used to collect leakage from the pumping equipment during operation. Bedplate drain surfaces are usually employed to contain the leakage of pumpage and other liquids during pump maintenance and removal or in the event of a seal or packing failure.

**Soleplates** Soleplates are cast-iron or steel pads located under the feet of the pump or its driver and are embedded in the foundation. The pump or its driver is doweled and bolted to them. Soleplates are customarily used for vertical dry-pit pumps and also for some of the larger horizontal units to save the cost of the large bedplates otherwise required.

**Centerline Support** For operation at high temperatures, the pump casing must be supported as near to its horizontal centerline as possible in order to prevent excessive strains caused by temperature differences. Such strains might seriously disturb the alignment of the unit and eventually damage it. Centerline construction is usually employed in boiler-feed, refinery, and hot-water circulating pumps (see Figure 101). The exact temperature at which centerline support construction becomes mandatory varies from 250 to 350°F (121 to 177°C).

**Horizontal Units Using Flexible Pipe Connections** The previous discussion of bedplates and supports for horizontal-shaft units assumed their application would be to pumps with piping setups that do not impose hydraulic thrusts on the pumps. If flexible pipe connections or expansion joints are desirable in the suction or discharge piping of a pump (or in both), the pump manufacturer should be so advised for several reasons. First, the pump casing will be required to withstand various stresses caused by the resultant hydraulic thrust load. Although this is rarely a limiting or dangerous factor, it is best that the manufacturer have the opportunity to check the strength of the pump casing. Second, the resulting hydraulic thrust has to be transmitted from the pump casing through the casing feet to the bedplate or soleplate and then to the foundation. Usually, horizontal-shaft pumps are merely bolted to their bases or soleplates, and so any tendency to displacement is resisted only by the frictional grip of the casing feet on the base and by relatively small dowels. If flexible pipe joints are used, this attachment may not be sufficient to withstand the hydraulic thrust. If high hydraulic thrust loads are to be encountered, therefore the pump feet must be keyed to the base or supports. Similarly, the

bedplate or supporting soleplates must be of a design that will permit transmission of the load to the foundation. Each of these design elements must be checked to confirm their capability to withstand hydraulic thrust loads from flexible pipe connections. Preferably expansion joints will be restrained to avoid transmitting loads to the pump nozzles.

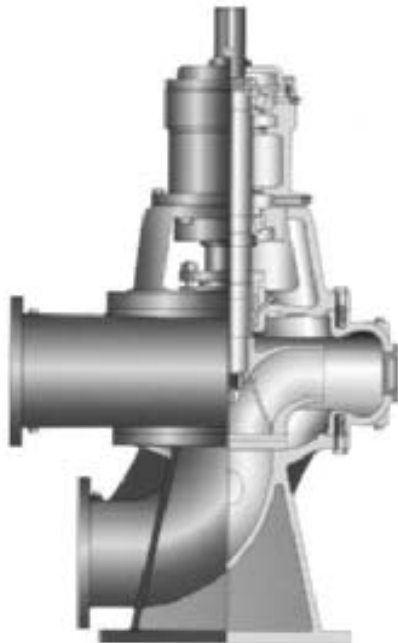
## VERTICAL PUMPS

---

Vertical-shaft pumps fall into two classifications: dry-pit and wet-pit. Dry-pit pumps are surrounded by air, and the wet-pit types are either fully or partially submerged in the liquid handled.

**Vertical Dry-Pit Pumps** Dry-pit pumps with external bearings include most small, medium, and large vertical sewage pumps, most medium and large drainage and irrigation pumps for medium and high heads, many large condenser circulating and water supply pumps, and many marine pumps. Sometimes the vertical design is preferred (especially for marine pumps) because it saves floor space. At other times, it is desirable to mount a pump at a low elevation because of suction conditions, and it is then also preferable or necessary to have the pump driver at a high elevation. The vertical pump is normally used for large capacity applications because it is more economical than the horizontal type, all factors considered.

Many vertical dry-pit pumps are basically horizontal designs with minor modifications (usually in the bearings) to adapt them for vertical-shaft drive. This is not true of small- and medium-sized sewage pumps, however. In these units, a purely vertical design is the most popular. Most of these sewage pumps have elbow suction nozzles (see Figures 102 through 104) because their suction supply is usually taken from a wet well adjacent to the



**FIGURE 102** Section of a vertical sewage pump with end-suction (elbow) and side discharge (FlowsERVE Corporation)



**FIGURE 103** An installed vertical sewage pump similar to that shown in Figure 102 (Flowserve Corporation)



**FIGURE 104** Vertical sewage pump with a direct-mounted motor (Flowserve Corporation)

pit in which the pump is installed. The suction elbow usually contains a handhole with a removable cover to provide easy access to the impeller.

To dismantle one of these pumps, the stuffing box head must be unbolted from the casing after the intermediate shaft or the motor and motor stand have been removed. The rotor assembly is drawn out upward, complete with the stuffing box head, the bearing





**FIGURE 105** Vertical bottom-suction volute pumps installed in a sewage pumping station (Flowsolve Corporation)

housing, and the like. This rotor assembly can then be completely dismantled at a convenient location.

Vertical-shaft installations of single-suction pumps with a suction elbow are commonly furnished with either a pedestal or a base elbow (refer to Figure 102), both of which can be bolted to soleplates or even grouted in. The grouting arrangement is not desirable unless there is full assurance that the pedestal or elbow will never be disturbed or that the grouted space is reasonably regular and the grout will separate from the pump without excessive difficulty.

Vertical single-suction pumps with bottom suction are commonly used for larger sewage, water supply, or condenser circulating applications. Such pumps are provided with wing feet that are bolted to soleplates grouted in concrete pedestals or piers (see Figure 105). Sometimes the wing feet may be grouted right in the pedestals. These must be suitably arranged to provide proper access to any handholes in the pump and to allow clearance for the elbow suction nozzles if these are used.

If a vertical pump is applied to a condensate service or some other service for which the eye of the impeller must be vented to prevent vapor binding, a pump with a bottom single-inlet impeller is not desirable because it does not permit effective venting. Neither does a vertical pump employing a double-suction impeller (see Figure 106). The most suitable design for such applications incorporates a top single-inlet impeller (see Figure 107).

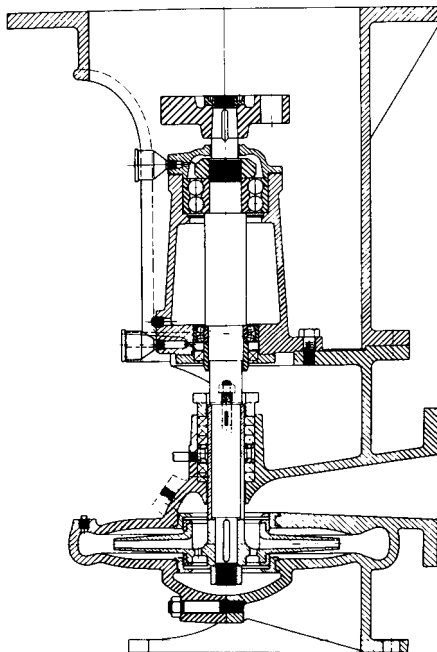
If the driver of a vertical dry-pit pump can be located immediately above the pump, it is often supported on the pump itself (refer to Figure 104). The shafts of the pump and driver may be connected by a flexible coupling, which requires that each have its own thrust bearing. If the pump shaft is rigidly coupled to the driver shaft or is an extension of the driver shaft, a common thrust bearing is used, normally in the driver.

Although the driving motors are frequently mounted on top of the pump casing, one important reason for the use of the vertical shaft design is the possibility of locating the motors at an elevation sufficiently above the pumps to prevent the accidental flooding of the motors. The pump and its driver may be separated by an appreciable length of shafting, which may require steady bearings between the two units. Subsection 6.3.1 discusses the construction and arrangement of the shafting used to connect vertical pumps to drivers located some distance above the pump elevation.

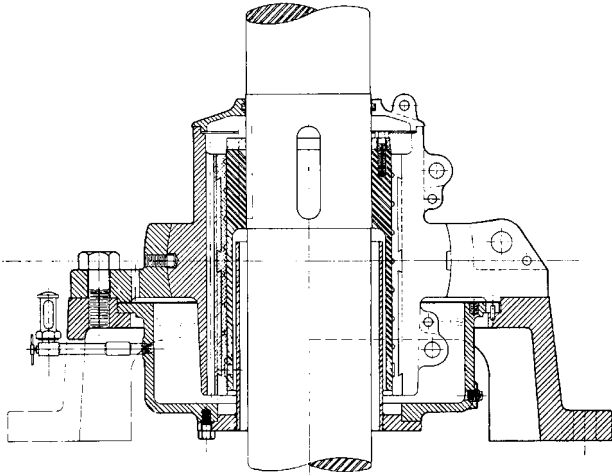
Bearings for vertical dry-pit pumps and for intermediate guide bearings are usually antifriction grease-lubricated types to simplify the problem of retaining a lubricant in a housing with a shaft projecting vertically through it. Larger units, for which antifriction bearings are not available or desirable, use self-oiling, babbitt steady bearings with spiral



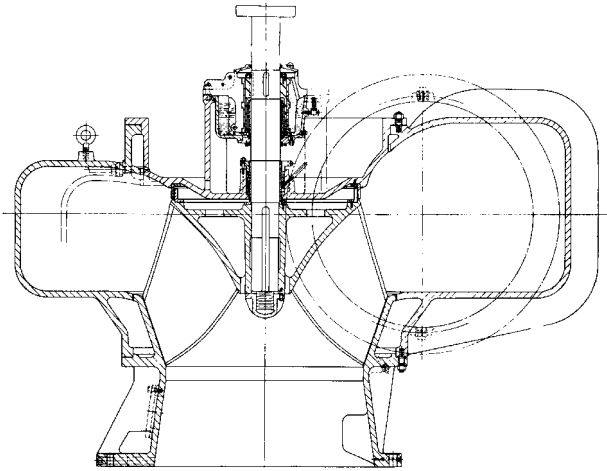
**FIGURE 106** A vertical double-suction volute pump with a direct-mounted motor (Flowsolve Corporation)



**FIGURE 107** A section of a vertical pump with a top-suction inlet impeller (Flowsolve Corporation)



**FIGURE 108** A self-oiling, babbitt steady bearing for large vertical shafting (Flowserve Corporation)



**FIGURE 109** A section of a large, vertical, bottom-suction volute pump with a single sleeve bearing (Flowserve Corporation)

oil grooves (see Figures 108 and 109). Figure 109 illustrates a vertical dry-pit pump design with a single-sleeve line bearing. The pump is connected by a rigid coupling to its motor (not shown), which is provided with a line and a thrust bearing.

Vertical dry-pit centrifugal pumps are structurally similar to horizontal-shaft pumps. It is to be noted, however, that many of the large, vertical, single-stage, single-suction (usually bottom) volute pumps that are preferred for large storm water pumpage, drainage, irrigation, sewage, and water supply projects have no comparable counterpart among horizontal-shaft units. The basic U-section casing of these pumps, which is structurally weak, often requires the use of heavy ribbing to provide sufficient rigidity. In the comparable water turbine practice, a set of vanes (called a *speed ring*) is employed between the casing and the runner to act

as a strut. Although the speed ring does not adversely affect the operation of a water turbine, it would function basically as a diffuser in a pump because of the inherent hydraulic limitations of that construction. Some high-head pumps of this type have been made in the twin-volute design. The wall separating the two volutes acts as a strengthening rib for the casing, thus making it easier to design a casting strong enough for the pressure involved.

**Bases and Supports for Vertical Pumping Equipment** Vertical-shaft pumps, like horizontal-shaft units, must be firmly supported. Depending upon the installation, the unit can be supported at one or several elevations. Vertical units are seldom supported from walls, but even that type of support is sometimes encountered.

Occasionally, a nominal horizontal-shaft pump design is arranged with a vertical shaft and a wall used as the supporting foundation. Regular horizontal-shaft units can be used for this purpose without modification, except that the bedplate is attached to a wall. Careful attention must be given to the arrangement of the pump bearings to prevent the escape of the lubricant. Installations of double-suction, single-stage pumps with the shaft in the vertical position are relatively rare, except in some marine or navy applications. Hence, manufacturers have few standard pumps of this kind arranged so that a portion of the casing forms the support (to be mounted on soleplates). Figure 106 shows such a pump, which also has a casing extension to support the driving motor.

**Vertical Wet-Pit Pumps** Vertical pumps intended for submerged operations are manufactured in a great number of designs, depending mainly upon the service for which they are intended. Small pumps of this type are often referred to as *sump pumps*. Wet-pit centrifugal pumps can be classified in the following manner:

- Vertical turbine pumps
- Propeller or modified propeller pumps
- Volute pumps

**Vertical Turbine Pumps** Vertical turbine pumps were originally developed for pumping water from wells and have been called *deep-well pumps*, *turbine well pumps*, and *bore-hole pumps*. As their application to other fields has increased, the name *vertical turbine pumps* has been generally adopted by manufacturers. This is not too specific a designation because the term *turbine pump* has been applied in the past to any pump employing a diffuser. There is now a tendency to designate pumps using diffusion vanes as *diffuser pumps* to distinguish them from *volute pumps*. As that designation becomes more universal, applying the term *vertical turbine pumps* to the construction formerly called *turbine well pumps* will become more specific.

The largest fields of application for the vertical turbine pump are pumping from wells for irrigation and other agricultural purposes, for a municipal water supply, and for industrial water supplies, as well as for processing, circulating, refrigerating, and air conditioning. This type of pump has also been utilized for brine pumping, mine dewatering, oil field repressuring, and other purposes.

These pumps have been made for capacities as low as 10 or 15 gpm (2 or 3 m<sup>3</sup>/h) and as high as 25,000 gpm (5700 m<sup>3</sup>/h) or more and for heads up to 1,000 feet (300 m). Most applications naturally involve the smaller capacities. The capacity of the pumps used for bored wells is naturally limited by the size of the well as well as by the rate at which water can be drawn without lowering its level to a point of insufficient pump submergence.

Vertical turbine pumps should be designed with a shaft that can be readily raised or lowered from the top to permit proper positioning of the impeller in the bowl. An adequate thrust bearing is also necessary to support the vertical shafting, the impeller, and the hydraulic thrust developed when the pump is in service. As the driving mechanism must also have a thrust bearing to support its vertical shaft, it is usually provided with one large enough to carry the pump parts as well. For these two reasons, the hollow-shaft motor or gear is most commonly used for vertical turbine pump drives. In addition, these pumps are sometimes made with their own thrust bearings to allow for a belt drive or for a drive through a flexible coupling by a solid-shaft motor, gear, or turbine. Dual-driven pumps usually employ an angle gear with a vertical motor mounted on its top.



**FIGURE 110** A vertical turbine pump design with enclosed impellers and: a) enclosed line shafting and b) open-line shafting (Flowsolve Corporation)

The design of vertical pumps illustrates how a centrifugal pump can be specialized to meet a specific application. Figure 110 illustrates a turbine design with closed impellers and enclosed-line shafting and another turbine design with closed impellers and open-line shafting.

The bowl assembly, or section, consists of the suction case (also called *suction head* or *inlet vane*), the impeller or impellers, the discharge bowl, the intermediate bowl or bowls (if more than one stage is involved), the discharge case, the various bearings, the shaft, and the miscellaneous parts, such as keys, impeller-locking devices, and the like. The column pipe assembly consists of the column pipe, the shafting above the bowl assembly, the shaft bearings, and the cover pipe or bearing retainers. The pump is suspended from the driving head, which consists of the discharge elbow (for above ground discharge), the motor or driver and support, and either the stuffing box (in an open-shaft construction) or the assembly for providing tension on the cover pipe and introducing a lubricant into it. Below ground discharge is taken from a tee in the column pipe, and the driving head functions principally as a stand for the driver and a support for the column pipe.

Liquid in a vertical turbine pump is guided into the impeller by the suction case or head. This may be a tapered section for the attachment of a conical strainer or suction pipe, or it may be a bell mouth.

Semiopen and enclosed impellers are both commonly used. For proper clearances in the various stages, the semiopen impeller requires more care in assembly on the impeller shaft and more accurate field adjustments of the vertical shaft position in order to obtain the best efficiency. Enclosed impellers are favored over semiopen ones because wear on the latter reduces capacity, which cannot be restored unless new impellers are installed. Normal wear on enclosed impellers does not affect impeller vanes, and worn clearances may be restored by replacing wearing rings. The thrust produced by semiopen impellers may be as much as 150 percent of that by enclosed impellers.

Occasionally, in power plants, the maximum water level that can be carried in the condenser's hot well will not give adequate NPSH for a conventional horizontal condensate pump mounted on the basement floor, especially if the unit has been installed in a space originally allotted for a smaller pump. Building a pit for a conventional horizontal condensate pump or a vertical dry-pit pump that will provide sufficient submergence involves considerable expense. Pumps of the design shown in Figure 111 have become quite popular in such applications. This is basically a vertical turbine pump mounted in a tank (often called a can) that is sunk into the floor. The length of the pump has to be such that sufficient NPSH will be available for the first-stage impeller design, and the diameter and length of the tank have



**FIGURE 111** Vertical turbine can pump for condensate service (Flowservice Corporation)



**FIGURE 112** Vertical propeller pump installed (Flowsolve Corporation)

to allow for proper flow through the space between the pump and tank and then for a turn and flow into the bell mouth. Installing this design in an existing plant is naturally much less expensive than making a pit because the size of the hole necessary to install the tank is much smaller. The same basic design has also been applied to pumps handling volatile liquids that are mounted on the operating floor and not provided with sufficient NPSH.

**Propeller Pumps** Originally, the term *vertical propeller pump* was applied to vertical wet-pit diffuser or turbine pumps with a propeller or axial-flow impellers, usually for installation in an open sump with a relatively short setting (see Figures 112 and 113). Operating heads exceeding the capacity of a single-stage axial-flow impeller might call for a pump of two or more stages or a single-stage pump with a lower specific speed and a mixed-flow impeller. High enough operating heads might demand a pump with mixed-flow impellers and two or more stages. For lack of a more suitable name, such high-head designs have usually been classified as propeller pumps also.

Although vertical turbine pumps and vertical modified propeller pumps are basically the same mechanically and could even be of the same specific speed hydraulically, a basic turbine pump design is suitable for a large number of stages. A modified propeller pump design, however, is basically intended for a maximum of two or three stages.

Most wet-pit drainage, low-head irrigation, and storm water installations employ conventional propeller or modified propeller pumps. These pumps have also been used for condenser circulating services, but a specialized design dominates this field. As large power plants are usually located in heavily populated areas, they frequently have to use badly contaminated water (both fresh and salt) as a cooling medium. Such water quickly short-



**FIGURE 113** Vertical propeller pump with above ground discharge (Flowserve Corporation)



**FIGURE 114** Vertical pull-out design allows the rotating element and critical non-rotating wear components to be removed for inspection and replacement without removing the complete pump (Flowserve Corporation)

ens the life of fabricated steel. Cast iron, bronze, or an even more corrosion-resistant cast metal must therefore be used for the column pipe assembly. This requirement means a very heavy pump if large capacities are involved. To avoid the necessity of lifting this large mass for maintenance of the rotating parts, some designs (one of which is illustrated in Figure 114) are built so that the impeller, diffuser, and shaft assembly can be removed from the top without disturbing the column pipe assembly. These designs are commonly designated as *pullout* designs.

Like vertical turbine pumps, propeller and modified propeller pumps have been made with both open- and enclosed-line shafting. Except for condenser circulating services, enclosed shafting, using oil as a lubricant but with a grease-lubricated tail bearing below the impeller, seems to be favored. Some pumps handling condenser



circulating water use enclosed shafting but with water (often from another source) as the lubricant, thus eliminating any possibility of oil getting into the circulating water and coating the condenser tubes.

Propeller pumps have open propellers. Modified propeller pumps with mixed-flow impellers are made with both open and closed impellers.

**Volute Pumps** A variety of wet-pit pumps are available. The liquid pumped, be it clean water, sewage, abrasive liquids or slurries, dictates whether a semiopen or an enclosed impeller will be used, whether the shafting will be open or closed to the liquid pumped, and whether the bearings will be submerged or located above the liquid.

Figure 115 illustrates a single-volute pump with a single-suction enclosed nonclog impeller, no pump-out vanes or wearing-ring joints on the back side of the impeller, and enclosed shafting. The pump is designed to be suspended from an upper floor by means of a drop pipe and for pumping sewage or other solid-laden liquids. To seal against leakage along the shaft at the point where it passes through the casing, a seal chamber or a stuffing box is provided. The design of a stuffing box can be either like the one shown in Figure 116, which uses rings of packing and a spring-loaded gland, or the one shown in Figure 117, which uses U-cup packing requiring no gland. The pump shown in Figure 115 uses two sleeve bearings above the impeller. The bottom bearing is grease-lubricated, and a seal is provided to prevent grease leakage as well as to keep out any grit. The upper bearing connects the shaft cover pipe to the pump-bearing bracket and the upper end of the cover pipe to the floorplate. This bearing is gravity-feed oil-lubricated. If intermediate bearings are required, they are also supported by the cover pipe and are oil-lubricated. The pump thrust is carried by the motor, which can be either a hollow-shaft or a solid-shaft construction. The latter type requires the use of a rigid coupling between the pump and motor shafts.

In most applications, these volute-type pumps have been replaced with vertical wet-pit pumps with the stuffing box/seal chamber in the discharge head (see Section 9.2, Figure 4b).

A design that uses open shafting and no seal chamber or stuffing box at the pump casing, incorporating its own thrust bearing, is shown in Figure 118. The impeller shown in Figure 118 is of the vortex type (sometimes called a *recessed impeller*, as shown in Figure 119), which is suitable for pumping heavy concentrations of solid material (such as sludges or slurries) or in certain food-processing applications, but other types of impellers can be substituted. Pumped liquid leakage from the casing is relieved back to the suction through holes in the support pipe. The seal chamber or stuffing box at the driver floor elevation is used only when gas tight construction is desired. The lower and any intermediate sleeve bearings are grease-lubricated as shown, but gravity-feed oil lubrication is also available in other designs. The upper antifriction thrust bearing is grease-lubricated. A solid shaft motor and a flexible shaft are used.

Figure 120 illustrates what is called a *cantilever-shaft pump*, which has the unique feature of having no bearings below the liquid surface. The shaft is exposed to the liquid pumped. External antifriction grease-lubricated bearings are provided above the floor and are properly spaced to support the rigid shaft. They carry both the thrust and the radial load. A flexible coupling is used between the pump and the solid-shaft motor. The stuffing box at the floorplate may be eliminated if holes are provided in the drop pipe to maintain the liquid level in the pipe even with the sump liquid level. Either semiopen or enclosed impellers may be used.

An interesting design of the wet-pit pump is shown in Figure 121. It uses a single-stage, double-suction impeller in a twin-volute casing. Because the axial thrust is balanced, the thrust bearing need carry only the weight of the rotating element. The pump requires no stuffing box or mechanical seal. The shaft is entirely enclosed, and the bearings are externally lubricated, either with oil or with water. The lower bearing receives its lubrication from an external pipe connection.

The term sump pump ordinarily conveys the idea of a vertical wet-pit pump that is suspended from a floorplate or sump cover. It could be supported by a foot on the bottom of a well, be motor-driven and automatically controlled by a float switch, and be used to remove drainage collected in a sump. The term does not indicate a specific construction, for both diffuser and volute designs are used. These may be single-stage or multistage and have open or closed impellers of a wide range of specific speeds.

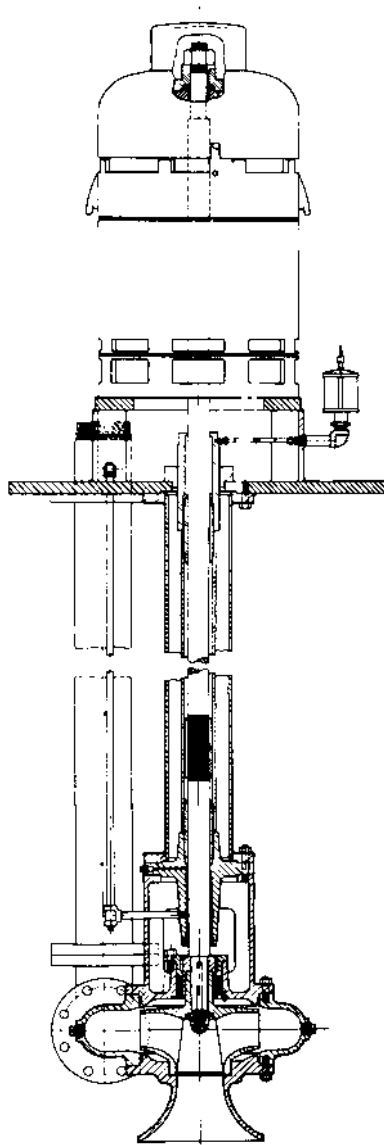


FIGURE 115 A section of a vertical wet-pit, nonclogging pump (Flowsolve Corporation)

For small capacities driven by fractional-horsepower motors, *cellar drainers* can be used. These are small and usually single-stage volute pumps with single-suction impellers (either top or bottom suction) supported by a foot on the casing. The motor is supported well above the impeller by some form of column enclosing the shaft. These drainers are made as complete units, including float, float switch, motor, and strainers (see Figure 122).

The larger sump pumps are usually standardized but obtainable in any length, with covers of various sizes (on which a float switch may be mounted) and the like. Duplex

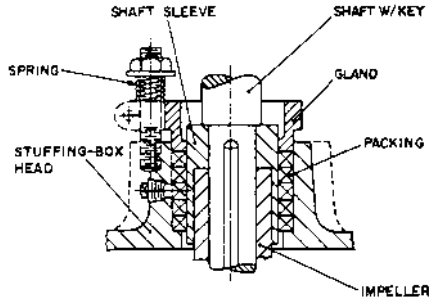


FIGURE 116 A typical stuffing box arrangement

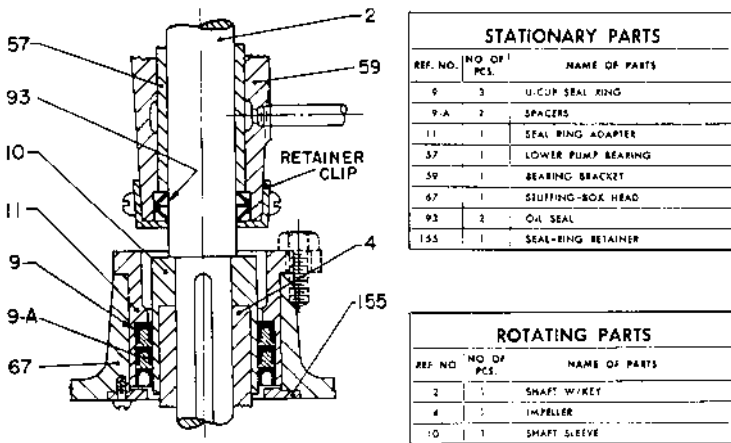
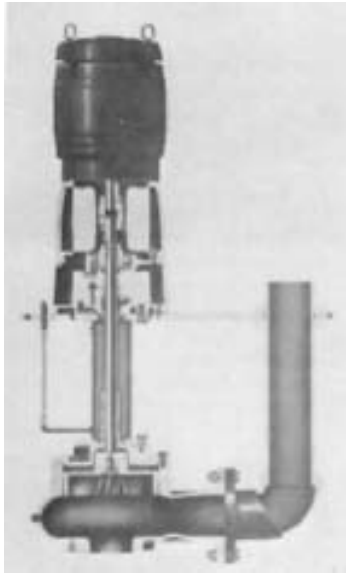


FIGURE 117 A stuffing box arrangement with U-cup packing (Flowserve Corporation)

units, that is, two pumps on a common sump cover (sometimes with a hole for access to the sump), are often used (see Figure 123). Such units may operate their pumps in a fixed order, or a mechanical or electric alternator may be used to equalize their operation.

**The Application of Vertical Wet-Pit Pumps** Like all pumps, the vertical wet-pit pump has advantages and disadvantages. One advantage is that installation does not require a separate dry pit to collect the pumped liquid. If the impeller (first-stage impeller in multistage pumps) is submerged, no priming problem exists and the pump can be automatically controlled without fear of its ever running dry. Moreover, the available NPSH is greater (except in closed tanks) and often permits a higher rotative speed for the same service conditions. A second advantage is that the motor or driver can be located at any desired height above any flood level.

It has the following mechanical disadvantages: (1) the possibility of freezing when idle, (2) the possibility of damage by floating objects if the unit is installed in an open ditch or similar installation, (3) the inconvenience of lifting out and dismantling for inspection and repairs, no matter how small, and (4) the pump bearings have a relative short life unless the water and bearing design are ideal. In summary, the vertical wet-pit pump is the best pump available for some applications. It's not ideal but can be the most economical for certain installations, a poor choice for some, and the least desirable for still others.



**FIGURE 118** A vertical wet-pit volute pump with open shafting, no stuffing box, and its own thrust bearing (Aurora Pump)

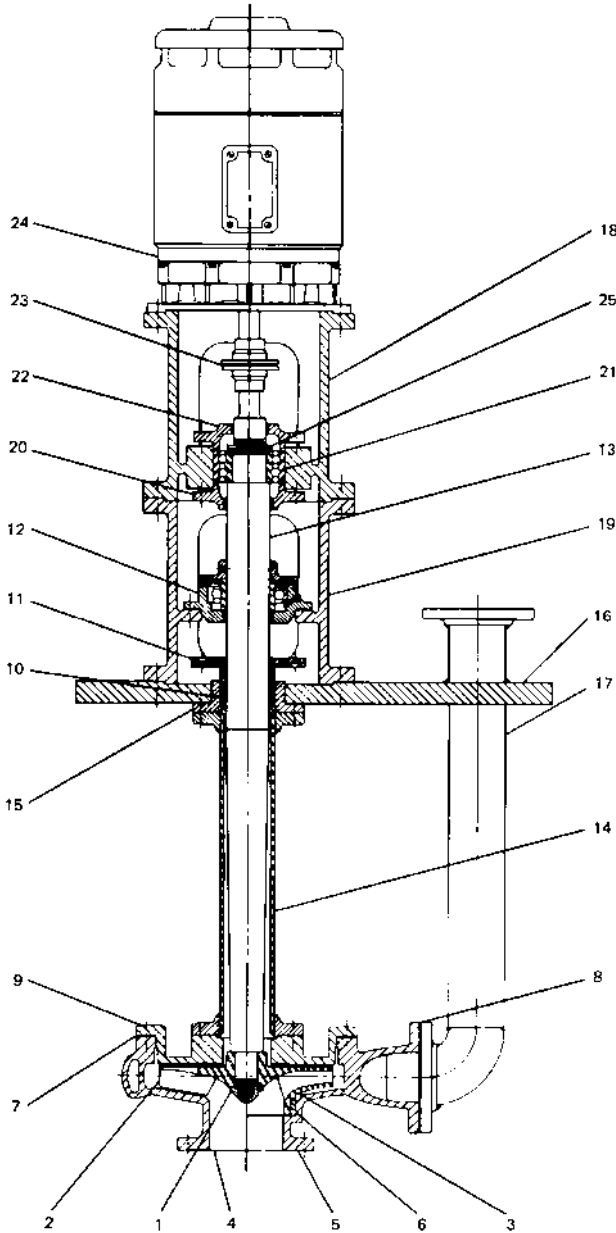


**FIGURE 119** The principle operation of the vortex pump in Figure 118 (Aurora Pump)

***Axial Thrust in Vertical Pumps with Single Suction Impellers*** The subject of axial thrust in horizontal pumps has already been discussed in this section. When pumps are installed in a vertical position, additional factors need be taken into account when determining the amount and direction of the thrust to be absorbed in the thrust bearings.

The first and most significant of these factors is the weight of the rotating parts, which is a constant downward force for any given pump, completely independent of the pump operating capacity or total head. Since in most cases the single-suction impellers of vertical pumps are mounted with the suction eye facing downward, the normal hydraulic axial thrust is exerted downward and the weight of the rotating parts is additive to this axial thrust.

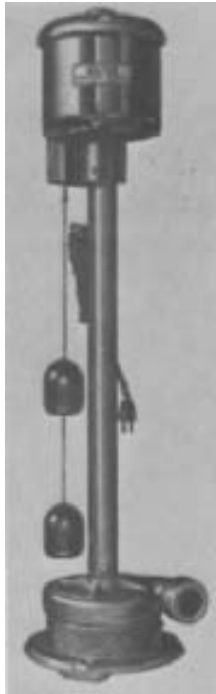
The second factor involves the dynamic force (or change in momentum) caused by the change in the direction of flow, from vertical to either horizontal or partly horizontal, as the pumped liquid flows through the impeller. This force acts upward and balances a small portion of the hydraulic downthrust and of the rotor weight. The magnitude of this force for water having a specific weight (force) of  $62.34 \text{ lb/ft}^3$  ( $9.79 \text{ kN/m}^3$ ) is



**FIGURE 120** Vertical wet-pit cantilever-type volute pump: (1) impeller nut, (2) open impeller, (3) closed impeller; (4) open casing, (5) closed casing, (6) casing wearing ring, (7) casing gasket, (8) discharge flange gasket, (9) back cover, (10) packing or mechanical seal, (11) packing or seal gland, (12) radial bearing, (13) shaft, (14) supporting pipe, (15) separate stuffing box, (16) sump cover, (17) discharge pipe, (18) upper motor pedestal, (19) lower motor pedestal, (20) lower thrust bearing cover, (21) thrust bearing, (22) upper thrust bearing cover, (23) coupling, (24) motor, (25) bearing locknut and washer (Laurence Pump)



**FIGURE 121** Double-suction, wet-pit pump (Flowserve Corporation)



**FIGURE 122** A cellar-drainer sump pump (Sta-Rite Products)

in USCS units

$$F_u = \frac{KV_e^2 A_e}{2g(2.31)}$$

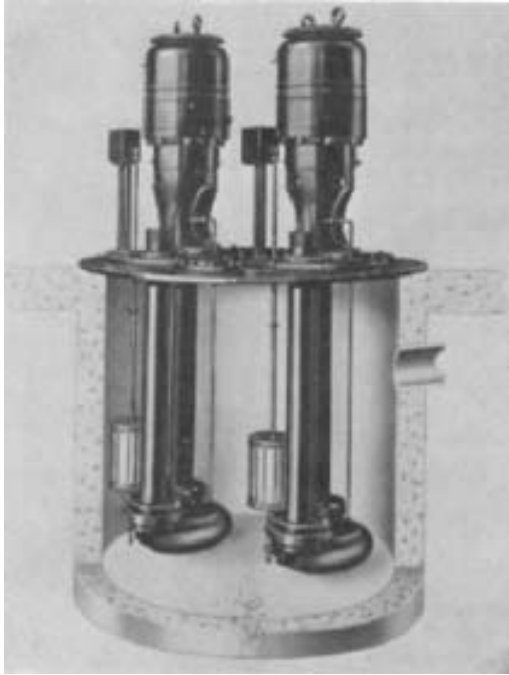
in SI units

$$F_u = \frac{KV_e^2 A_e}{2g(1.02)}$$

where  $F_u$  = upthrust, lb (N)

$K$  = constant related to the impeller type

$V_e$  = velocity in the impeller eye ft/s (m/s)



**FIGURE 123** A duplex sump pump (Economy Pump)

$$A_e = \text{net eye area, in}^2(\text{cm}^2)$$

$$g = 32.2 \text{ ft/s}^2(9.81 \text{ m/s}^2)$$

The constant  $K$  is 1.0 for a fully radial-flow impeller, less than 1.0 for a mixed-flow impeller, and essentially zero for a fully axial-flow impeller.

Under normal operating conditions, the upward thrust caused by the change of momentum is hardly significant in comparison with the downward thrust caused by the unbalanced pressures acting on the single-suction impeller. Consider the example of an impeller with the following characteristics:

Capacity	2,500 gpm (568 m <sup>3</sup> /h)
Total head	231 ft (70.4 m)
Net pressure	100 lb/in <sup>2</sup> (6.89 bar)
Unbalanced eye area	40 in <sup>2</sup> (258 cm <sup>2</sup> )

If we neglect the effect of the pressure distribution on the shrouds of the impeller, the downward thrust is

in USCS units  $100 \times 40 = 4000 \text{ lb}$

in SI units  $6.89 \times 10^5 \times \frac{258}{10,000} = 17,800 \text{ N}$

The upward force caused by the change of momentum is

$$\begin{aligned} \text{in USCS units} \quad & \frac{1.0 \times \left( \frac{2500 \times 0.32}{40} \right)^2 \times 40}{64.4 \times 2.31} = 107.5 \text{ lb} \\ \text{in SI units} \quad & \frac{1 \times \left( \frac{568 \times 10,000}{258 \times 3600} \right)^2 \times 258}{2 \times 9.81 \times 1.02} = 481 \text{ N} \end{aligned}$$

This is certainly negligible relative to the downward hydraulic axial thrust.

The situation is quite different, however, during the startup of a vertical pump. Although the motor may get up to full speed in just a few seconds, it takes a certain amount of time for the total head to increase from zero that corresponding to the normal operating capacity. Consequently, the pump will be operating in a very high capacity range. Since the upward force caused by the change of momentum varies as the square of the capacity while the downward axial thrust caused by pressure differences is very low, there can be a momentary net upward force, or upthrust. This means that thrust bearings intended to accommodate the axial thrust of vertical pumps must be capable of accommodating some thrust in the upward direction in addition to the normal downward thrust. This is particularly true for pumps with relatively low heads per stage and with short settings because in these units the rotor weight does not at all times compensate for the upthrust from the change in momentum.

Particular care must be exercised in defining the range of vertical movement allowed for the thrust bearings because any such movement must remain within the displacement limits of any mechanical seal used in the pump.

In rather rare cases, a close-coupled vertical pump is operated at such a high capacity that a continuous net upthrust is generated. Such operations can damage the pump because the line shaft is operated in compression and may buckle, causing vibration and bearing wear. The manufacturer's comments should be invited if such an operation is contemplated.

**Shaft Elongation in Vertical Pumps** The elongation of a vertical pump shaft is caused by three separate phenomena: (1) the tensile stress caused by the weight of the rotor, (2) the tensile stress caused by the axial thrust, and (3) the thermal expansion of the shaft.

In most cases, the tensile stress created by the axial thrust is several times greater than that created by the weight. In a typical example of a 16,000-gpm (3636-m<sup>3</sup>/h) pump designed for a 175-ft (53.3 m) head and 50 ft (15.25 m) long, the elongation caused by the weight of a 1600-pound (726 kg) impeller will be of the order of 0.0033 in (0.084 mm). The elongation caused by the axial thrust will be approximately 0.0315 in (0.8 mm).

The elongation caused by thermal expansion has to be considered from two angles. First, if the shaft and the stationary parts are built of materials that have essentially the same coefficient of expansion, both will expand equally and no significant relative elongation will take place. Second, if the pumps are operated in essentially the same range of temperatures in which they were assembled, no significant relative expansion will take place, even if dissimilar coefficients of expansion are involved. Whatever the case, the pump manufacturers take these factors into consideration by providing the necessary vertical end-play between the stationary and rotating pump components.

**Loads on Foundations of Vertical Pumps** If the motor support is integral with the pump discharge column, as in Figures 110, 112, and 113, and if the hydraulic thrust is carried by the motor thrust bearing, this thrust is not additive to the deadweight of the pump and of its motor plus the weight of the water contained in the pump, insofar as the load on the foundations is concerned. This is because the pump and motor mounted in this fashion form a self-contained entity and all internal forces and stresses are balanced within this entity. If the pump and motor are supported separately, however, as in Figure 124, and are joined by a rigid coupling that transmits the pump hydraulic thrust to the motor thrust bearing, the foundations will carry the following loads when the pump is running:



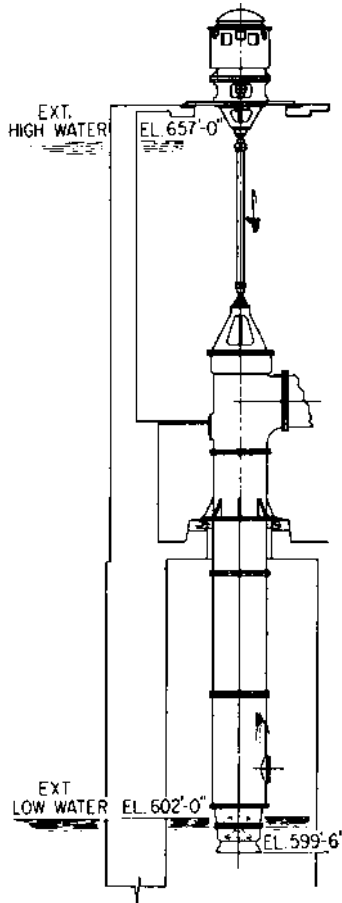


FIGURE 124 The vertical pump and driving motor supported separately (Flowsolve Corporation)

- *The foundation supporting the motor:* the weight of the motor plus the weight of the pump rotor plus the axial hydraulic thrust developed by the pump
- *The foundation supporting the pump:* the weight of the pump stationary parts plus the weight of the water in the pump, including the water in the discharge pipe supported by the foundation, less the axial hydraulic thrust developed by the pump

Since when the pump is idle the foundation supporting the pump is not benefited by the reduction in load equivalent to the axial hydraulic thrust, both running and idle operating conditions must be considered in this case.

**Typical Arrangements of Vertical Pumps** A pump is only part of a pumping system. The hydraulic design of the system external to the pump will affect the overall economy of the installation and can easily have an adverse effect upon the performance of the pump itself. Vertical pumps are particularly susceptible because the small floor space occupied

by each unit offers the temptation to reduce the size of the station by placing the units closer together. If the size is reduced, the suction arrangement may not permit the proper flow of water to the pump suction intake. Recommended arrangements for vertical pumps are discussed in Section 10.1.

### **SPECIAL PURPOSE PUMPS**

---

In addition to the more or less general purpose pumps described on the preceding pages, literally hundreds of centrifugal pumps are intended for very specific applications. Although it is impossible to describe every one of these special purpose designs, many of them are discussed and illustrated in Sections 9.1 through 9.22, covering a variety of pump services. However, several specific designs are seeing rapidly increasing usage and so are discussed in greater detail here.

**Submersible Motor-Driven Wet-Pit Pumps** The installation of conventional vertical wet-pit pumps with the motor located above the liquid level may require a considerable length of drive shafting, particularly in the case of deep settings. The addition of this shafting, of the many line bearings, and possibly of an external lubrication system may represent a major portion of the total installed cost of the pumping unit. Furthermore, shaft alignment becomes more critical, and shaft elongation and power losses increase rapidly as the setting is increased, especially for deep-well pumps.

A great variety of submersible motors have been developed to obviate these shortcomings. They are described in Subsection 6.1.1, and a classification of the various types of such motors is presented in Figure 26 of that subsection. Submersible wet-pit pumps eliminate the need for extended shafting, shaft couplings, a mechanical seal or stuffing box, a subsurface motor stand, and, in some cases, an expensive pump house. Both vertical turbine and volute-type wet-pit pumps may be so driven.

Figures 125 and 126 illustrate, respectively, the external appearance and a cross section of a vertical turbine pump driven by a submersible motor located at the bottom of the pump. The pump suction is through a perforated strainer located between the motor and the first-stage impeller bowl. There is, of course, no shafting above the pump and the pump-and-motor unit is supported by the discharge pipe only. No external lubrication is required. The motor is completely enclosed and oil-filled and is provided with a thrust bearing to carry the pump downthrust. A mechanical seal is provided at the motor shaft extension, which is connected to the pump shaft with a rigid coupling. Only a discharge elbow and the electric cable connection are seen above the surface support plate. On occasion, this type of pump is used horizontally as a booster pump in a pipeline, and in such cases the elbow at the discharge is eliminated.

Vertical wet-pit volute-type sump pumps can be obtained with close-coupled submersible motors for drainage, sewage, process, and slurry services. Figure 127 illustrates dual submersible sewage pumps in a below ground collecting tank. The pumps (see Figure 128) are supported by guide rails that make it possible to lower and raise the pumps by means of a chain hoist. During this operation, the discharge pipe is connected and disconnected without dewatering the tank. Other arrangements use foot-supported pumps with rigid discharge piping.

Motors used for this type of construction are usually hermetically sealed, employing a double mechanically sealed oil chamber with a moisture-sensing probe to detect any influx of conductive liquid past the outer seal. Controls to start and stop the pump motors can be either an air compressor bubbler system or level-sensing switches that tilt when floated (refer to Figure 127).

Small portable pumps are available with flexible discharge hoses and built-in water-level motor control switches activated by trapped air pressure. Motors for these pumps are usually oil-filled and have a single mechanical shaft seal but are also available in a hermetically sealed design. The submersible motors are cooled by the liquid in which they are immersed and therefore should not be run dewatered, although some motors can operate for short periods (10 to 15 min.) this way.

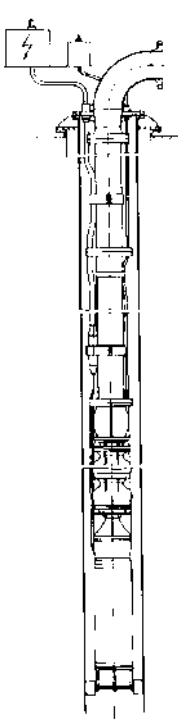


FIGURE 125 Vertical turbine pump driven by a submersible motor (Flowserve Corporation)

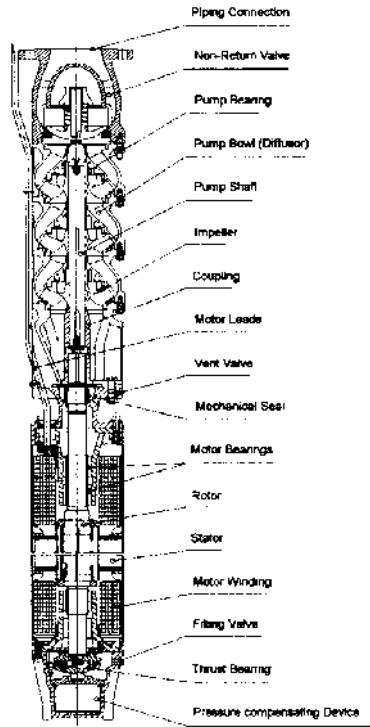


FIGURE 126 Cross-sectional view of a submersible pump (Flowserve Corporation)



FIGURE 127 Dual submersible sewage pumps in a below ground collecting tank (Flowserve Corporation)

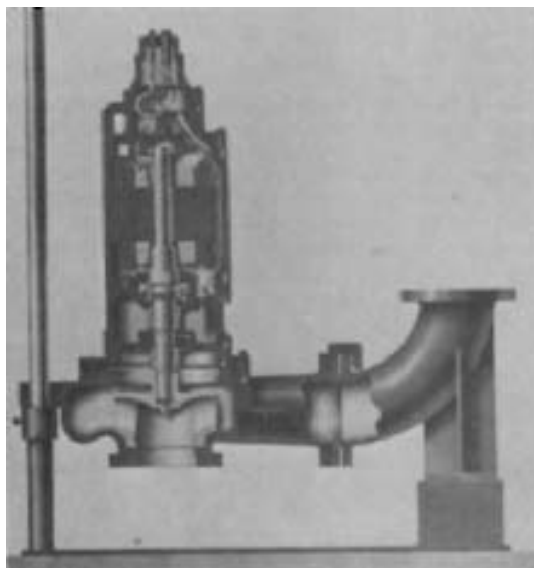


FIGURE 128 A section of a submersible sewage pump shown in Figure 127 (Flowsolve Corporation)

In a pump-motor combination (see Figure 129), the motor is cooled by the pumped liquid as it moves through a passage around the sides of the motor. This design also uses a pressurized oil-seal chamber to assure positive sealing.

**Sealless Pumps** Completely leakproof pumps are available for pumping corrosive, volatile, radioactive, and otherwise hazardous liquids. Canned motor pumps (see Figure 130) are an assembly of a standard centrifugal pump and a squirrel-cage induction motor in a hermetically sealed unit. Modifying a recirculating flow system in a canned motor pump can allow it to be used in applications at up to 1000°F (538°C).

Magnetic drive pumps (see Figure 131) are an assembly of a rotor, an impeller, product lubricated bearings, and a magnetic carrier inside an isolation shell or diaphragm. This rotor is driven by magnets outside the shell or diaphragm. No mechanical connection exists between the driven magnets and the driving magnets. No seals exist and thus we have the term “sealless.” Sealless pumps are described in detail in Subsection 2.2.7.

**Straight-Radial-Vane High-Speed Pumps** For handling volatile liquids at low flow rates and high heads, the straight-radial-vane impeller in a diffuser casing offers several advantages. Volatile, low-specific-gravity, poor-lubricity liquids require larger running clearances, which is not possible with conventional high-head multistage centrifugal or positive displacement pumps. High-head pumping of these liquids can be handled by operating this completely open impeller at very high speeds through an integral gear increaser and with very large impeller-to-casing clearance, typically 0.030 to 0.070 in (0.76 to 1.8 mm). Tests of one manufacturer’s design have shown this clearance can increase to 0.125 in (3.2 mm) with virtually no change in performance, and consequently there is no need to provide adjustment for impeller axial clearance. A pump of this design can also run “dry,” as liquid lubricity is not required to lubricate the bearings, which can be separately lubricated (providing the mechanical seal is lubricated).

Figure 132 illustrates one manufacturer’s design of a radial-vane high-speed pump. The impeller rotates in a circular casing that has a single emission point leading to a conical diffusion section. The advantage of this type of casing is that the conversion to pressure occurs outside the circular housing, thus eliminating any recirculation forces that

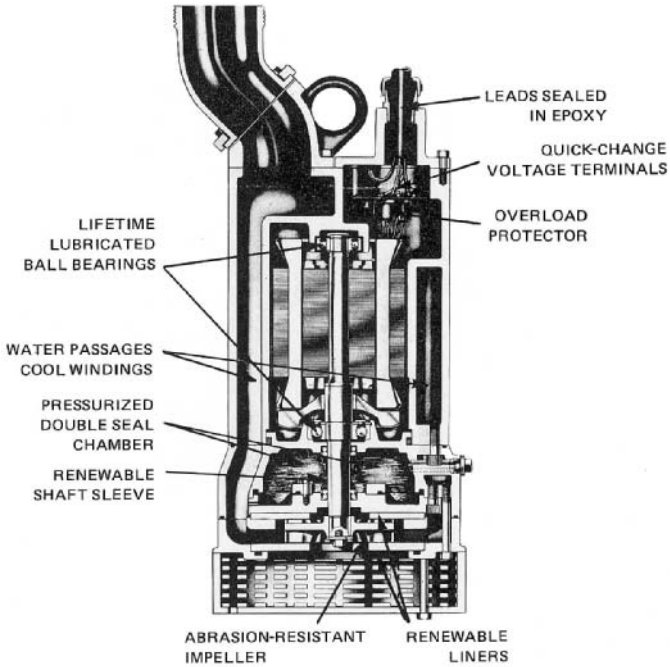


FIGURE 129 A portable submersible pump (Peabody Barnes)

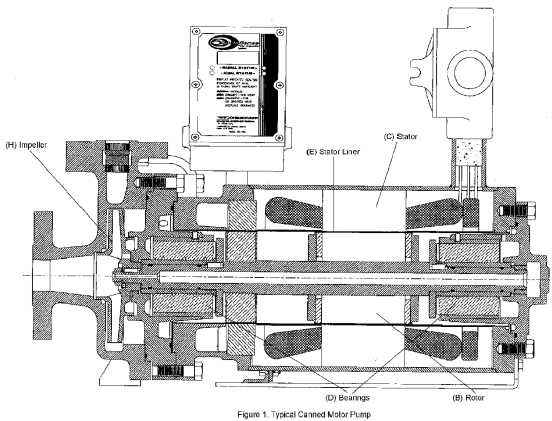
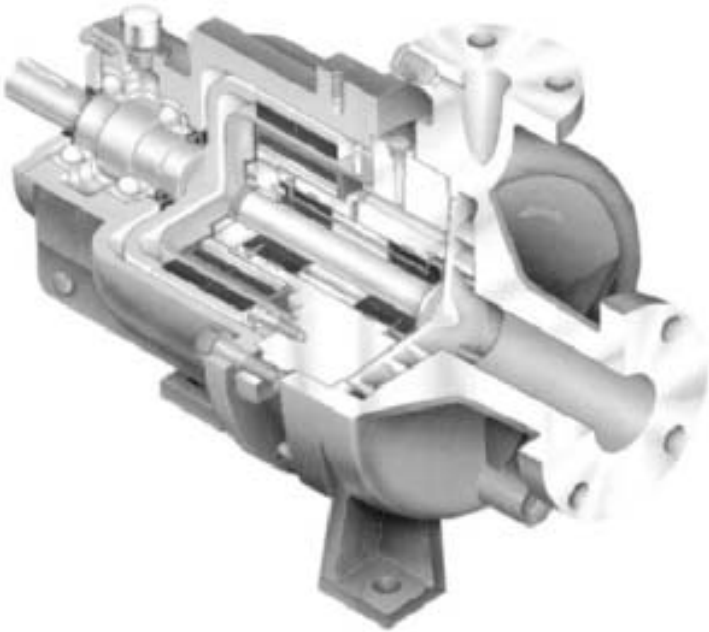
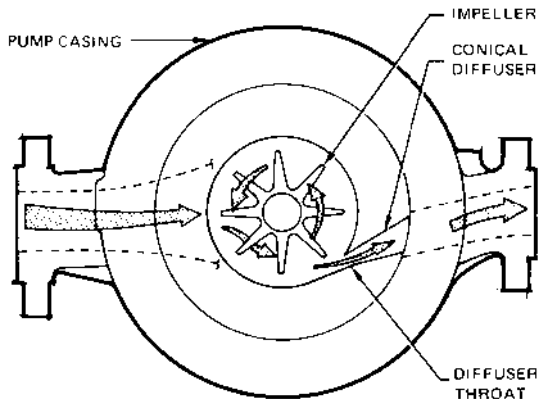


FIGURE 130 Typical canned motor pump (Ref. Subsection 2.2.7) (Crane Chempump)

would require a close clearance between the impeller and casing. For higher flow ranges, a double emission point design, as shown in Figure 133, is used. This additional emission acts like a double-volute casing in conventional centrifugal pumps.

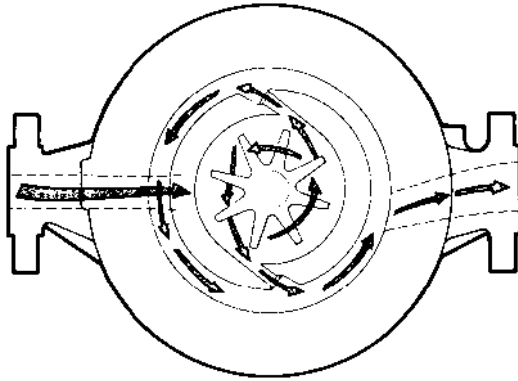


**FIGURE 131** Typical magnetic drive sealless pump (Ref. Subsection 2.2.7) (Flowserve Corporation)

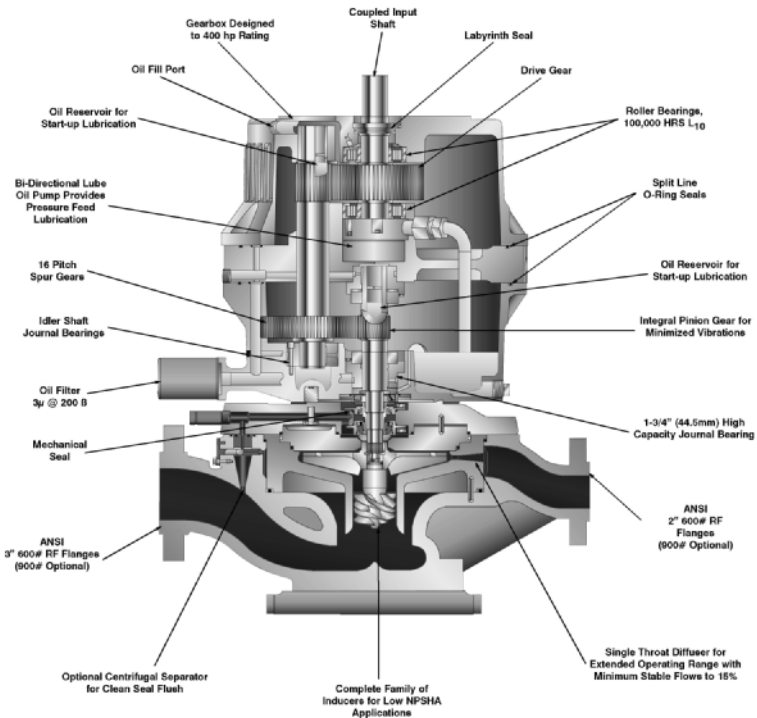


**FIGURE 132** A straight-radial-vane impeller in a single emission-point, conical-diffuser circular casing (Sundyne Corporation)

Figure 134 is a sectional view of this pump with an integral speed increaser. Because of the high rotative speed, a single-stage pump can achieve the head normally associated with multistage centrifugal or positive displacement pumps. With this smaller liquid end and an integral gear box, cost and space savings can be appreciable.



**FIGURE 133** A straight-radial-vane impeller in a double-emission-point, conical-diffuser circular casing (Sundyne Corporation)



**FIGURE 134** A section of a straight-radial-vane impeller and inducer in a conical-diffuser circular casing with an integral gear increaser with the following: (1) pump casing, (2) impeller, (3) impeller bolt, (4) impeller tab washer, (5) inducer, (6) diffuser, (7) diffuser cover, (8) upper throttle bushing, (9) seal housing, (10) single shaft sleeve, (11) pump seal rotating face, (12) gearbox seal rotating face, (11) pump mechanical seal, (14) gearbox mechanical seal, (15) separator orifice, (16) separator fitting, (17) gearbox output housing, (18) gearbox input housing, (19) bearing plate, (20) interconnecting shaft, (21) low-speed shaft, (22) input gear, (23) lower idler gear, (24) high-speed shaft, (25) pinion gear, (26) idler shaft, (27) O-ring packings (Sundyne Corporation).

## 2.2.2 CENTRIFUGAL PUMP PACKING

JAMES P. NETZEL

Packing is used in the stuffing box of a centrifugal pump to control the leakage of the pumped liquid out, or the leakage of air in, where the shaft passes through the casing. This basic form of a seal can be applied in light- to medium-duty services and to those liquids that prove difficult for mechanical seals.

### ***THE DESIGN OF PACKING RINGS***

---

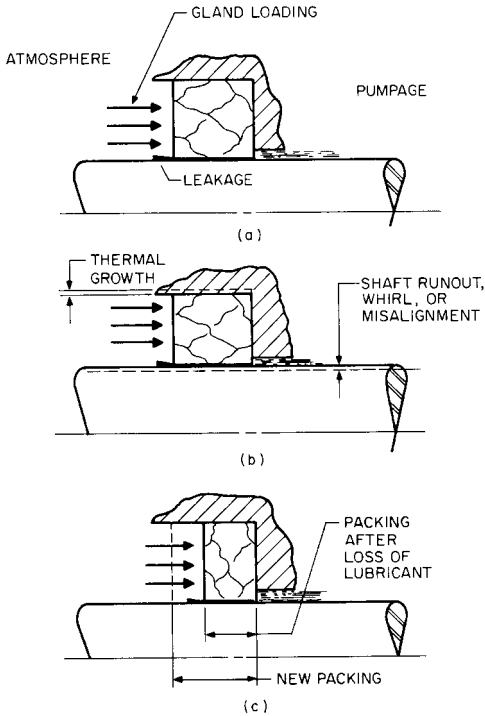
Packing may be referred to as compression, automatic, or floating. Each term describes the type of operation in which the packing will be used.

Automatic and floating packings require no gland adjustments in controlling leakage. Automatic packings are confined to a given space and are activated by the operating pressure. Automatic packing rings are designed in the form of V rings, U cups, and O rings. Floating packing includes piston rings and segmental rings that may be energized by a spring. These types of packing are commonly used in reciprocating applications.

Compression packing is most commonly used on rotating equipment. The seal is formed by the packing being squeezed between the inboard end of the stuffing box and the gland (see Figure 1a). A static seal is formed at the ends of the packing ring and at the inside diameter of the stuffing box. The dynamic seal is formed between the packing and shaft or shaft sleeve. Under a load, the packing deforms down against the shaft, controlling leakage. Some leakage along the shaft is necessary to cool and lubricate the packing. The amount of leakage will depend on the materials of construction for the packing, the operating conditions of the application, and the condition of the equipment.

Packing must be able to withstand equipment variables (see Figure 1b). The design of the packing ring and the materials of construction must be resilient to follow shaft runout and misalignments, as well as to compensate for thermal growth of the equipment without an appreciable increase in leakage.





**FIGURE 1** Compression packing; (a) new packing installation, (b) installation variables, (c) installation after many adjustments

As rotating equipment is operated, the load on the packing must be adjusted to control leakage (see Figure 1c). Care should be taken not to overtighten the packing. Most compression packings have a lubricant designed into them to prevent overheating of the packing or scoring of the shaft. Repeated adjustments will drive some of the lubricant from the packing, which will result in reduced operating time.

Compression packings are made of twisted, braided, woven, or wrapped elements formed into square or round cross-sections or other configurations. Square cross-sections are more common for rotating equipment.

A selection of the proper materials for the packing must include the chemical resistance to the product being sealed as well as the temperature, pressure, and shaft speed. Complete lists of the construction materials, packing lubricants and binders are given in Tables 1 and 2.

## OPERATING FUNDAMENTALS

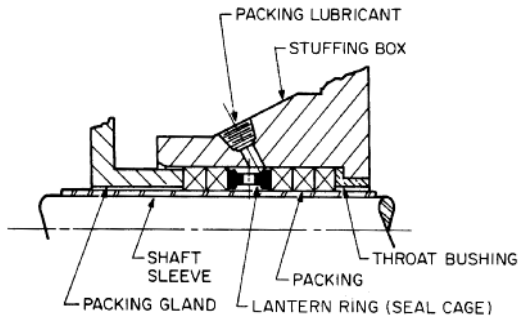
**The Size and Number of Packing Rings** The number of packing rings may vary, depending on the objective of the sealing system or the requirements of the rotating equipment. The most common packing arrangement for rotating equipment is illustrated in Figure 2. Three rings of packing are used to seal the process liquid from the packing lubricant. Two rings between the lantern and gland are used to restrict the leakage of the lubricant to the atmosphere. The size of the packing depends on the size of the equipment. Typically, for rotating shafts, the standard square size packings shown in Table 3 may be considered.

**TABLE 1** Common materials of construction for packing

Fibers				Metals
Mineral	Animal	Vegetable	Synthetic	Lead
Metal	Wool	Flax	Nylon	Copper
Graphite	Hair	Ramie	Rayon	Brass
	Leather	Jute	TFE	P-bronze
		Cotton	Carbon	Aluminum
		Paper	Aramid	Iron
			Polyamide	Stainless Steel
				Nickel
				Monel
				Inconel
				Zinc

**TABLE 2** Common lubricants and binders for packing

Lubricants		Dry Lubricants	Binders
Mineral	Animal	Graphite	Grease
Lube Oil	Tallow	Moly	Waxes
Paraffin	Glycerol	Mica	Elastomers
Petrolatum	Beeswax	Talc	TFE
Waxes	Lard Oil	Teflon	Other Resins
Greases	Fish Oil	Carbon	
	Soap	Tungsten Disulfide	
Vegetable	Synthetic		
Caster Oil	Oils		
Palm Oil	Waxes		
Cottonseed Oil	Fluorolubes		
Linseed Oil	Silicones		
Carnauba Wax			

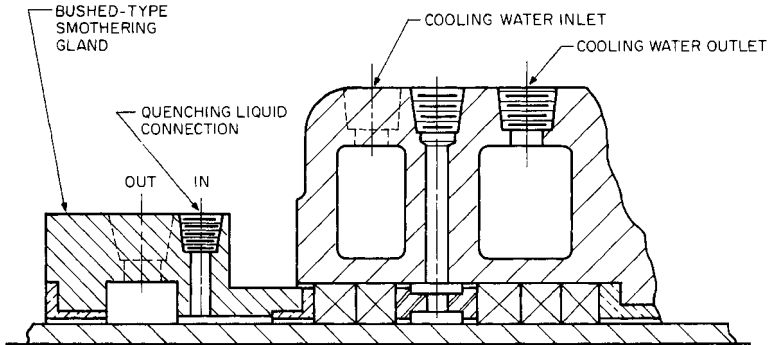
**FIGURE 2** Common packing arrangement

The packing size for an existing piece of equipment can be found by using the formula:

$$\text{Packing size} = \frac{\text{box ID} - \text{shaft or sleeve OD}}{2}$$

**TABLE 3** Packing sizes for rotating shafts

Shaft (or sleeve) Diameter, in (mm)	Packing size, in (mm)
$\frac{5}{8}$ to $1\frac{1}{8}$ (15 to 30)	$\frac{1}{4}$ (6.3)
$1\frac{1}{8}$ to $1\frac{7}{8}$ (30 to 50)	$\frac{5}{16}$ (8)
$1\frac{7}{8}$ to 3 (50 to 75)	$\frac{3}{8}$ (10)
3 to $4\frac{3}{4}$ (75 to 120)	$\frac{1}{2}$ (12.5)
$4\frac{3}{4}$ to 12 (120 to 305)	$\frac{5}{8}$ (16)

**FIGURE 3** A smothering gland and water-cooled stuffing box

For packing to operate properly, the finish on the shaft sleeve must be at least  $16\ \mu\text{in}$  ( $0.4\ \mu\text{m}$ ) centerline average (CLA) and the finish in the bore should be  $63\ \mu\text{in}$  ( $1.65\ \mu\text{m}$ ) CLA. The sleeve *must* be harder than the packing and chemically resistant to the liquid being sealed. If the sleeve has a coated material for a hard-wear surface, the sleeve must also have good thermal shock resistance.

**Lantern Rings (Seal Cages)** When an application requires that a lubricant be introduced to the packing, a lantern ring is used to distribute the flow (refer to Figure 2). This ring is used at or near the center of the packing installation. For ease of assembly, most lantern rings are axially split. The construction materials range from metal to TFE (tetrafluoroethylene). TFE lantern rings are usually filled with glass or with glass and molybdenum disulfide. They are inherently self-lubricating and will not score the shaft. A throat bushing at the bottom of the stuffing box can be used to provide a closer clearance with the shaft to prevent packing extrusion.

**Stuffing Box Gland Plates** All mechanical packings are mechanically loaded in the axial direction by the stuffing box gland (refer to Figure 2). In cases where leakage of the process liquid is dangerous or can vaporize and create a hazard to operating personnel, a smothering gland is used to introduce a neutral liquid at lower temperatures (see Figure 3). A sufficient quantity of quenching liquid should be used to eliminate the danger from the liquid being pumped. The neutral liquid circulated in the gland mixes with the leakage and carries it to a safe place for disposal. Close clearances in the gland control the leakage of the combined liquids to the atmosphere. This quench can also be used to protect the packing from any wear through abrasion, because the leakage cannot vaporize and leave behind abrasive crystals.

**TABLE 4** Leakage to prevent packing burning and sleeve scoring

Pressure lb/in <sup>2</sup> (bar)	Leakage, drops/min	cc/min
0–60 (0–4.0)	60	4
61–100 (4.1–6.8)		190
101–250 (6.9–17)		470

**TABLE 5** Typically coefficients of friction

Material	<i>f</i>
Plain cotton	0.22
TFE impregnated fiber	0.17
Grease-lube fiber	0.10
Flexible graphite	0.05

Glands are usually made of bronze, but cast iron or steel can be used for all-iron pumps. When iron or steel glands are used, they are normally bushed with a non-sparking material like bronze.

**Leakage and Power Consumption** The basic operating parameters for compression packing are the PV (pressure × velocity) factor and the projected bearing area of the assembly. Together they determine the rate of heat generation for the system. Some leakage of the product being sealed or of the packing lubricant is necessary to keep the packing from burning up or scoring the shaft sleeve. The minimum values for leakage at different packing pressures are given in Table 4. Flexible graphite and carbon filament compression packings can be used with reduced leakage rates, or in dry, gas-tight pump stuffing boxes, as the developed heat is dissipated through the packing and pump housing.

The exact pressure *P* between the shaft sleeve and the packing is a function of the pressure distribution over the length of the packing and the axial loading from the gland. For ease of calculation when determining the PV value, the gage pressure of the liquid at the packing is multiplied by  $\pi \times$  the packing ID  $\times$  rpm. The heat generation at the packing can then be estimated as

$$Q = \frac{f\pi^2 PND^2L}{CJ}$$

where *Q* = heat generated, Btu/min (W)

*f* = coefficient of friction

*P* = liquid pressure at packing, lb/in<sup>2</sup> gage (bar)

*N* = shaft speed, rpm

*D* = sleeve OD or packing ID, in (m)

*L* = sleeve length covered by packing, in (m)

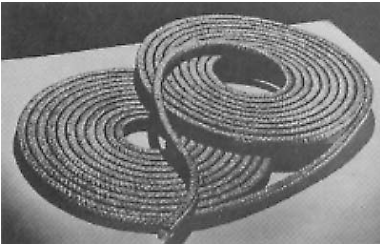
*C* = 12 (60 for SI units)

*J* = mechanical equivalent of heat = 778 ft · lb/Btu (1 N · m/s · W)

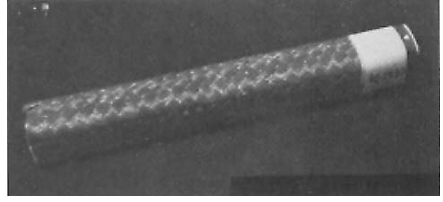
The coefficient of friction for various packings at a pressure of 100 lb/in<sup>2</sup> (6.8 bar) is given in Table 5. The heat generated by the packing must be removed by the leakage through the packing.

## APPLICATION INFORMATION AND SEALING ARRANGEMENTS

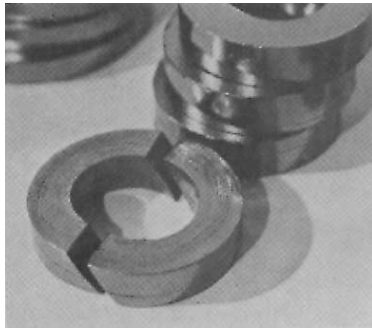
**Materials of Construction** Basically, stuffing box packing is a pressure breakdown device. In order for a packed stuffing box to operate properly, the correct packing must be



**FIGURE 4** Graphite acrylic packing in continuous form (John Crane Inc.)



**FIGURE 5** Non-asbestos packing (John Crane Inc.)



**FIGURE 6** Flexible graphite packing rings (John Crane, Inc.)

applied and the appropriate design features must be included in the system. Numerous types of packing materials are available, each is suited to a particular service. These may be grouped into three categories:

- 1. Non-asbestos packing** Since asbestos is no longer available as a packing material, other types of packing material are being used. These include cotton, TFE filament, Aramid fiber, aromatic polyamides, graphite/carbon yarn, and flexible graphite. All of these materials, with the exception of flexible graphite, can be impregnated with various lubricants. An example of graphited acrylic packing is shown in Figure 4. With the exception of flexible graphite, all the materials are of an interlaced construction for greater flexibility (see Figure 5). Packing made with this type of construction remains intact even if individual yarns wear away at the inside diameter of the packing.
- 2. Flexible graphite** These types of packing rings were originally available cut from laminated sheet stock that required the rings to be made with an interference fit. Flexible graphite rings are made today from ribbon tape that is easily compressed to the shaft and bore to affect a better seal. Flexible graphite rings are available in split or endless rings (see Figure 6) or as the ribbon tape itself for ease of maintenance and installation. Operating limits for non-asbestos packings are found in Table 6.
- 3. Metallic packing** The basic materials of construction are lead or babbitt, aluminum, and copper in either wire or foil form. Metallic packing rings have flexible cores of non-asbestos materials such as twisted glass fiber. The packing is impregnated with graphite grease and/or oil lubricants (see Figures 7 and 8). Babbitt is used in water and oil services at temperatures up to 450°F (229°C) and pressures up to 250 lb/in<sup>2</sup> (17 bar). Copper foil is used with water and low sulfur oils. Aluminum

**TABLE 6** Service limitations of common packing materials<sup>a</sup>

Packing Material	Pressure (max.) <sup>b</sup> lb/in <sup>2</sup> gage (bar)	PV rating (max.) <sup>c</sup> lb/in <sup>2</sup> gage · fpm (bar · m/s)	Temp. (max.) <sup>d</sup> °F (°C)	pH Range	Comments
Cotton	100 (6.8)		150(65.6)	5–7	Non-abrasive material; for cold water and dilute salt solutions
Flax/ramie	100 (6.8)	188,000 (65.8)	150 (65.6)	5–7	High, wet strength and excellent resistance to fungi and rotting; for cold water and dilute salt solutions
Plastic	100 (6.8) 250 (17)	188,000 (65.8) 471,000 (165)	600 (315.5) 150 (65.6)	4–8	Excellent sealing qualities, reacts well to gland adjustments, can extrude at higher pressure if not backed up by braided or metallic packing
Graphited acrylic	250 (17)	471,000 (165)	350 (175)	4–8	For mild chemicals and solvents
Acrylic TFE- impregnated	250 (17)	471,000 (165)	350 (175)	2–10	For mild chemicals and solvents
Babbitt (lead)	250 (17)	471,000 (165)	450( 232.2)	2–10	Shaft sleeve must have a Brinell hardness of 500 or more; for hot oils and boiler feed water
Aluminum or copper	250 (17)	471,000 (165)	750 (398.8)	3–10	Shaft sleeve must have a Brinell hardness of 500 or more; for hot oils and boiler feed water
TFE filament	250 (17)	471,000 (165)	500 (260)	0–14	For corrosive liquids and food service; usually requires slightly higher break-in leakage
Aramid fiber	250 (17)	471,000 (165)	500 (260)	3–11	Strong resilient packing; maximum speed 1,900 fpm (9.6 m/s); good in abrasives and chemicals
Graphite/carbon filament <sup>e</sup>	250 (17)	471,000 (165)	750 (398.8)	0–14	For corrosive liquids and high- temperature applications
Flexible Graphite <sup>f</sup>	250 (17)	471,000 (165)	1000 (540)	0–14	Excellent conductor of heat from the sealing surfaces; operates with minimum leakage; excellent radiation resistance

(a) Continuous lubrication introduced at the lantern ring. This table is only a guide. Consult the packing manufacturer with complete operating conditions for exact recommendations.

(b) Pressure relates to the operating pressure at the stuffing box.

(c) PV data based on a 2 in (5.08 cm) shaft at 1,750 and 3,600 rpm.

(d) Temperature is the product temperature.

(e) Functional temperature. Graphite can be used up to 3000°F (1650°C) in non-oxidizing atmospheres.

(f) Functional temperature. Flexible graphite can be used to 5300°F (2970°C) in non-oxidizing atmospheres.

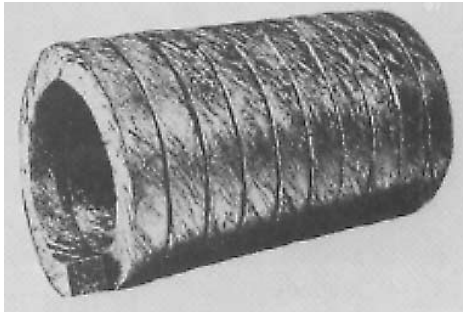


FIGURE 7 Metallic packing in spiral form (John Crane Inc.)



FIGURE 8 Metallic packing in ring form (John Crane Inc.)

is used in oil service and heat transfer fluids. Both copper and aluminum have a temperature range up to 1000°F (537°C) and pressures of 250 lb/in<sup>2</sup> (17 bar). Babbitt is not suitable for running against brass or bronze shaft sleeves, and where copper or aluminum is used, the sleeves should be 550 Brinell (55–60 Rockwell C) or harder.

Additional service limitations for common packing materials can be found in Table 6.

## ENVIRONMENTAL LIMITATIONS

---

**Pressure** Every pumping application results in either positive or negative pressure at the throat of the pump stuffing box. A positive pressure will force the liquid pumped through the packing to the atmosphere side of the pump. Higher pressure will result in greater leakage from the pump. This results in excessive tightening of the gland, which causes accelerated wear of the shaft or shaft sleeve and packing. For pressures at the stuffing box greater than 75 lb/in<sup>2</sup> (5.1 bar), some means of throttling the pressure should be considered. A combination of hard and soft rings die-formed to the exact stuffing box bore

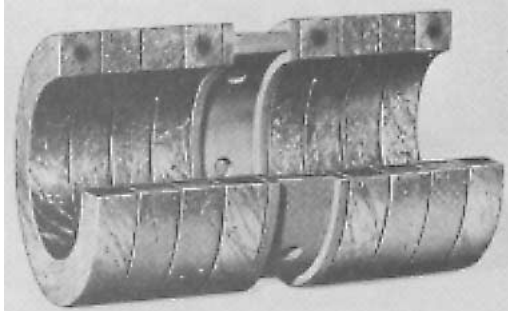


FIGURE 9 Combination of hard and soft packing (John Crane Inc.)

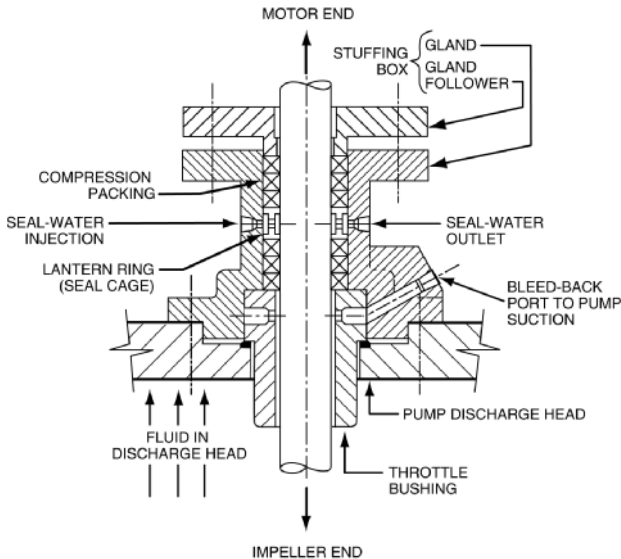


FIGURE 10 Compression packing with throttle bushing for pressure breakdown

and sleeve dimensions can be used (see Figure 9). Harder rings at the inboard end of the box and at the lantern ring and gland break down the pressure and prevent the extrusion of the packing.

If the packing itself cannot be used to break down the pressure, then a throttle bushing must be used (see Figure 10). This is a typical arrangement for a vertical turbine pump where the stuffing box is subject to the discharge pressure of the pump. Here the throttle bushing is used to bring the liquid to almost suction pressure, and most of the leakage through the bushing is bled back to the suction. When the suction pressure is less than atmospheric, as in condensate pump service, an orifice is used in the piping back to the suction in order to maintain pressure above atmospheric pressure in the stuffing box. This prevents air leakage into the pump and excessive flow and wear at the bushing.

When a pump is fitted with a bypass line from the discharge, a valve can also be used to reduce the pressure at the stuffing box. This is another method for reducing pressure for the benefit of the installation.



**Air Leakage** When the pressure at the stuffing box is atmospheric or just below during normal operation, a bypass from the pump casing discharge through an orifice can be used to inject liquid into the lantern ring. The sealing liquid will flow partly into the pump and partly out to the atmosphere, thereby preventing air from entering at the stuffing box. This arrangement is commonly used to handle clean, cool water. In some pumps, these connections are arranged so that liquid can be introduced into the lantern ring through internally drilled passages.

When the negative pressure is very low, such as when the suction lift is in excess of 15 ft (4.6 m), an independent injection of 10 to 25 lb/in<sup>2</sup> (4.8 to 11.7 bar) higher than the atmospheric pressure must be used on the pump. Otherwise, priming may be difficult. Hot well pumps or condensate pumps operate with as much as 28 in (0.7 m) of vacuum, and air leakage into the pump would occur even on standby service. Here a continuous injection of clean, cool water is required, or alternatively, a cross connection of sealing water to another operating pump will provide sealing pressure as long as one pump is operating. A lantern ring is provided for this, as shown in Figure 10.

**Temperature** The control of temperature at the stuffing box is an important factor in promoting the life of the packing. Even though packings are rated for high product temperatures, cooling in most cases is desirable. The heat developed at the packing must also be removed. The rules of thumb are as follows:

- For light service conditions with pressures at 15 lb/in<sup>2</sup> (1 bar) and temperatures at 200°F (90°C), cooling is desirable.
- For medium service conditions with pressures at 50 lb/in<sup>2</sup> (3.4 bar) and temperatures at 250°F (118°C), lantern ring cooling is desirable, such as one gpm (3.78 l/min) at 5 lb/in<sup>2</sup> (0.34 bar) above process pressure.
- For high service conditions with pressures at 100 lb/in<sup>2</sup> (6.8 bar) and temperatures at 300°F (131°C), lantern ring cooling is desirable, such as one gpm (3.78 l/min) at 5 lb/in<sup>2</sup> (0.34 bar) above process pressure plus a water-cooled stuffing box (refer to Figure 3).

When cooling water is required, it is circulated through the stuffing box at the lantern ring. For horizontal-shaft pumps, the inlet should be at the bottom, with the outlet at the top of the stuffing box. Some of the coolant may flow to the process liquid and some to the atmosphere. The outboard packing rings seal only the cool liquid.

If the product to be sealed will solidify, then the packing box will have to be heated before the pump is started. This can be accomplished by steam or electric tracing of the pump stuffing box.

**Abrasives** Liquids that contain abrasives in the form of *suspended solids* such as sand and dirt will shorten the life of the packing. Particles will imbed themselves in the packing and will begin to wear the shaft or shaft sleeve. Abrasives can be eliminated at the sealing surfaces by injecting a clean liquid into the lantern ring. The injection may take the form of a bypass line from the pump discharge through a filter or centrifugal separator. Where necessary, the clean injection may also be from an external source.

To keep the abrasives from the packing in horizontal-shaft pumps, the injection can be made directly to the inboard end of the stuffing box through the lantern ring (see Figure 11). A soft rubber gasket between the lantern ring and the box shoulder can be used to limit the flow of clean liquid and the ingress of abrasives.

When separators and filters cannot be used, an injection from an external source must be considered. Two rings of packing are located between the lantern ring and the inboard end of the stuffing box to keep the product dilution to a minimum. External flushing should be injected into the stuffing box at a pressure 10 to 25 lb/in<sup>2</sup> (1.7 bar) greater than the pressure at the inboard end of the box from the liquid being pumped. A regulating valve, illustrated in Figure 12, can be used to control the pressure and flow to the packing installation. Flow to the packing can be regulated to ensure the best operating environment for this seal, while conserving water used for injection.

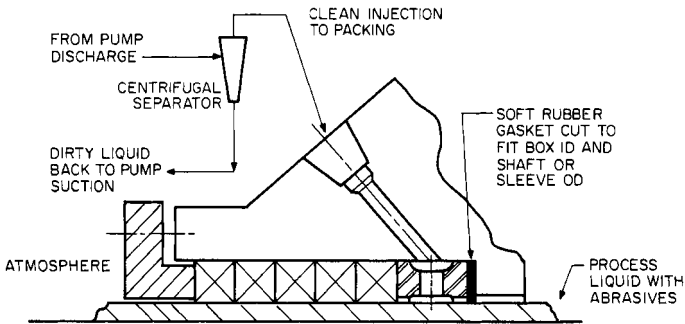


FIGURE 11 A clean injection through a centrifugal separator to keep abrasives out of the stuffing box

### Packing or Single Seal Flush

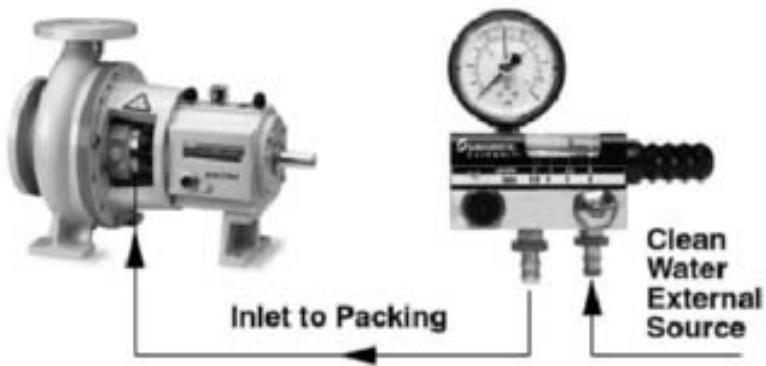


FIGURE 12 A regulation valve that controls and monitors the flow of water to the packing (Safematic)

*Dissolved solids* in the liquid being pumped can also create a wear problem. Here an increase or decrease in stuffing box temperatures may be necessary to keep solids in solution.

## INSTALLING CONTINUOUS COIL PACKING

To install continuous coil packing, perform the following steps:

1. Loosen and remove the gland from the stuffing box.
2. Using a packing puller, begin to remove the old packing rings.
3. Remove the split lantern ring (if present) and then continue removing the packing with the puller.
4. After the packing has been removed, check the sleeve for scoring and nicks. If the shaft sleeve or shaft cannot be cleaned up, it must be replaced. Check the size of the

stuffing box bore and the shaft sleeve or shaft diameter to determine which size packing should be used.

5. After the size of the packing has been determined, wrap the packing tightly around a mandrel, which should be the same size as the pump shaft or sleeve. The number of coils should be sufficient to fill the stuffing box. Cut the packing along one side to form the individual rings.
6. Before beginning the assembly of any packing material, be sure to read all the instructions from the manufacturer. Assemble the split packing rings on the pump. Each ring should be sealed individually with the split ends staggered 90° and the gland tightened to seal and fully compress the ring. Be sure the lantern ring is reinstalled correctly at the flush connection. Then back off the gland and retighten it, but only finger-tight. The exception to this procedure is that TFE packing should be installed one ring at a time, but not seated because TFE packings have high thermal expansion.
7. Allow excess leakage during break-in to avoid the possibility of rapid expansion of the packing, which could score the shaft sleeve or shaft so that leakage could not be controlled.
8. Leakage should be generous upon startup. If the packing begins to overheat at startup, stop the pump and loosen the packing until leakage is obtained. Restart only if the packing is leaking.

### **CAUSES FOR A SHORT PACKING LIFE** \_\_\_\_\_

In order for packing to operate properly, the equipment must be in good condition. Shafts should be checked for runout and eccentricity to be sure they are within the manufacturer's recommended tolerances. Surfaces in contact with the packing should be finished to the correct smoothness and tolerance. Table 7 lists common troubles that affect the packing life. Causes and possible cures are also given.

**TABLE 7** Packing troubles, causes, and cures

Trouble	Cause	Cure
No liquid delivered by pump	Lack of prime (packing loose or defective, to allowing air leak into suction)	Tighten or replace packing and prime pump.
Not enough liquid delivered by pump	Air leaking into stuffing box	Check for leakage through stuffing box while operating. If no leakage occurs after after reasonable gland adjustment, new packing may be needed. or Lantern ring may be clogged or displaced and may need centering in line with sealing liquid connection. or Sealing liquid line may be clogged. or Shaft or shaft sleeve beneath packing may be badly scored, allowing air to be sucked into pump.
	Defective packing	Replace packing and check the smoothness of the shaft or shaft sleeve.
Not enough pump pressure	Defective packing	As per preceding
Pump works for a while and then quits	Air leaks into stuffing box	As per preceding
Pump takes too much power	Packing too tight	Release gland pressure and retighten reasonably. Keep leakage flowing. If none, check packing, sleeve, or shaft.
Pump leaks excessively at stuffing	Defective packing	Replace worn packing or replace packing damaged by lack of lubrication.
	Wrong type of packing	Replace packing not properly installed or run in. Replace improper packing with correct grade for liquid being handled.
	Shaft or shaft sleeve scored	Put in lathe and machine-true and smooth or replace. Recheck dimensions for correct packing size.
Stuffing box overheats	Packing too tight	Release gland pressure and retighten.
	Packing not lubricated	Release gland pressure and replace all packing if any burnt or damaged.
	Wrong grade of packing	Check with pump or packing manufacturer for correct grade.
	Insufficient cooling water to jacket	Check for open supply line valve or clogged line.
	Stuffing box improperly packed	Repack.
Packing wears too fast	Shaft or shaft sleeve worn or scored	Remachine or replace.
	Insufficient or no lubrication	Repack, making sure packing is loose enough to allow some leakage.
	Packing packed improperly	Repack properly, making sure all old packing is removed and the box is clean.
	Wrong grade of packing	Check with pump or packing manufacturer.
	Pulsating pressure on external seal liquid line	Remove cause of pulsation.

**FURTHER READING**

---

Berzinsa, A. "Finer Points of Compression Packing Help with Centrifugal Pumps," *Power*, June 1974, pp. 58–59.

Ciffone, J. G. "Packing," John Crane Mechanical Maintenance Training Center, Morton Grove, Illinois, November 1994.

Crane Packing Company. *Engineering Fluids Sealing, Materials, Design and Applications: An Information Compendium of Technical Papers*. Morton Grove, IL 1979.

Elonka, S. "Packing: Power Practical Manual," *Power*, March 1955, pp. 107–130.

Krisle, O.M. "How to Get Longer Life out of Pump Packing and Shaft Sleeve," *Water and Sewage Works*, June 1967, pp. 199–201.

Neale, M.J., "Packing Glands," *Tribology Handbook* (Sec. A36), Wiley, New York; 1973.

## 2.2.3

# CENTRIFUGAL PUMP MECHANICAL SEALS

JAMES P. NETZEL

Mechanical seals have been used for many years to seal any number of liquids at various speeds, pressures, and temperatures. Today plant operators are benefiting from improved seal technologies driven by the U.S. Clean Air Act of 1990, and the American Petroleum Institute (API) Standard 682. These new seal technologies are based on advanced computer programs used to optimize seal designs, which are then verified through performance testing at simulated refinery conditions required by the API. The results to date indicate not only an improvement in emissions control, but also a major increase in equipment reliability.

### **CLASSES OF SEAL TECHNOLOGY**

---

Emerging seal technologies are providing clear choices for sealing. Various plant services require the application of these new technologies for emissions control, safety, and reliability. Sealing systems are now available that are based on the preferred method of lubrication to be used. These classes of seals are as follows:

#### **1. Contacting liquid lubricated seals:**

- Normally, a single seal arrangement is cooled and lubricated by the liquid being sealed. This is the most cost-effective seal installation available to the industry.
- Dual seals are arranged to contain a pressurized or non-pressurized barrier or buffer liquid. Normally, this arrangement will be used on applications where the liquid being sealed is not a good lubricating fluid for a seal and for emissions containment. These arrangements require a lubrication system for the circulation of barrier or buffer liquids.

## 2. Non-contacting gas lubricated seals:

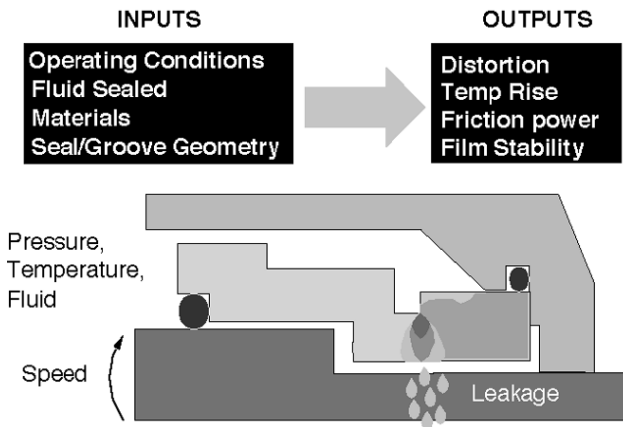
- Dual non-contacting, gas-lubricated seals are pressurized with an inert gas such as nitrogen.
- Dual non-contacting, gas-lubricated seals are used in a tandem arrangement and pressurized by the process liquid being sealed, which is allowed to flash to a gas at the seal. A tandem seal arrangement is used on those liquids that represent a danger to the plant environment. For non-hazardous liquids, a single seal can be used.

Each of these solutions has been used on difficult applications to increase the *mean time between maintenance* (MTBM).

## SEAL DESIGN

Advancing the state-of-the-art sealing systems are new suites of computer programs such as C'Steady<sup>SM(1)</sup> used to analyze the performance of both contacting and non-contacting seal designs during steady-state and transient conditions. This type of finite analysis considers all of the operating conditions, the fluid sealed, the materials of construction, and seal geometry. The outputs from the program are seal distortion, temperature distribution, friction power, actual *PV* (pressure  $\times$  velocity), leakage, the percentage of face in liquid or vapor, and fluid film stability (see Figure 1). This type of analysis requires accurate fluid and material properties. The results from the program can predict the success or failure of a given installation.

For example, a mixture of liquid hydrocarbon made up of ethane, propane, butane, and hexane has to be sealed. This is a new application. The operating condition is 1,300 psig at 70°F. The shaft speed is 3,600 rpm. To determine the performance of this seal prior to installation, an analysis must be made. The results of this study indicate stable operations for a contacting seal, as shown in Figure 2. This study was used to predict seal performance. Actual field results from this difficult service were excellent at startup and during equipment operation.



**FIGURE 1** C'Steady<sup>SM</sup> fluid film model for a mechanical seal (John Crane Inc.)

<sup>1</sup>Service Mark of John Crane Inc.

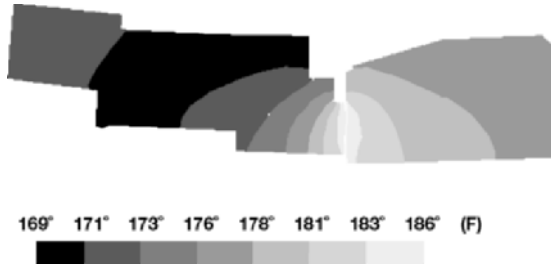


FIGURE 2 C-Stedy output for a successful seal on high pressure light hydrocarbon service (John Crane Inc.)

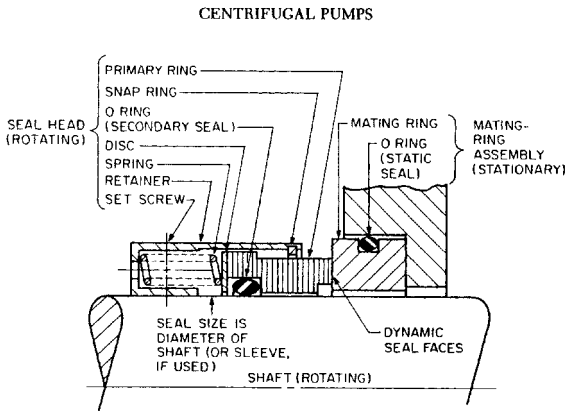


FIGURE 3 The basic components of a mechanical seal

These state-of-the-art computer tools not only predict performance, but they also can be used to determine any short seal life. By using a series of calculations per second, this type of analysis can be used to create an animation that will visibly show changes to a seal at startup and during fluctuations in operating conditions. A seal can be examined for stable and unstable operations. This is a useful analysis tool for critical applications.

## DESIGN FUNDAMENTALS

**Contacting Liquid Lubricated Seals** The basic components of a mechanical seal are the primary and mating rings. Together they form the dynamic sealing surfaces, which are perpendicular to the shaft. The primary ring is part of the seal head assembly, while the mating ring and static seal form a second assembly, making a complete installation for a pump. These basic seal parts are shown in Figure 3. For slower and normal shaft speeds, the seal head assembly will rotate with the shaft, while on high shaft speeds, the seal head assembly will be held stationary to the equipment.

The only difference between contacting and non-contacting seal technologies is found in the design of the seal faces. Each system has the same type and number of parts. Each has its own area of application for maximum sealing efficiency. Non-contacting seal technology will be discussed later.



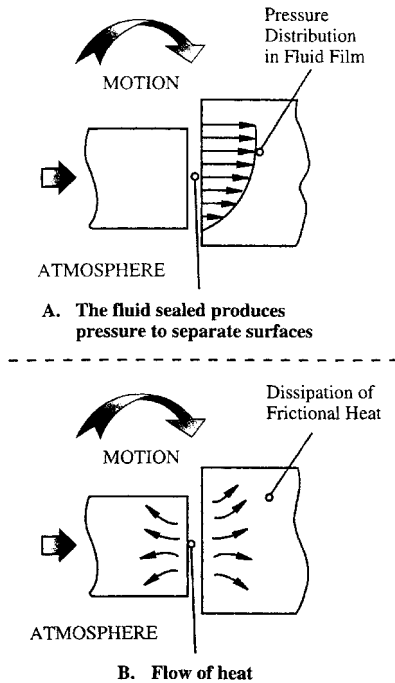


FIGURE 4 Processes involved at contacting seal faces

In a contacting seal, as the shaft begins to rotate, a small fluid film develops, along with frictional heat from the surfaces in sliding contact. These processes occurring at the seal faces are shown in Figure 4. The amount of heat developed at the seal faces must be removed to prevent the liquid being sealed from flashing or beginning to carbonize. Seal heat can be removed with a seal flush located at the seal faces. To analyze the performance of a seal and determine amount of cooling, the following calculations can be made.

**Seal Balance** The greatest concern to the seal user is the dynamic contact between the mating seal surfaces. The performance of this contact determines the effectiveness of the seal. If the load at the seal faces is too high, the liquid at the seal faces will vaporize or carbonize and the seal faces can wear out. Damage to the seal faces can occur due to unstable conditions. A high wear rate from solid contact and leakage can occur if the bearing limits of the materials are exceeded. Seal balancing is a feature that is used to avoid these conditions and provide for a more efficient installation.

The pressure in any seal chamber acts equally in all directions and forces the primary ring against the mating ring. Pressure acts only on the annular area  $a_c$  (see Figure 5a), so that the force in pounds (Newtons) on the seal face is as follows:

$$F_c = pa_c$$

where  $p$  = seal chamber pressure, lb/in<sup>2</sup> (N/m<sup>2</sup>) and

$a_c$  = hydraulic closing area, in<sup>2</sup> (m<sup>2</sup>)

The pressure in lb/in<sup>2</sup> (N/m<sup>2</sup>) between the primary ring and mating ring is

$$P'_f = \frac{F_c}{a_o} = \frac{pa_c}{a_o}$$

where  $a_o$  = hydraulic opening area (seal face area), in<sup>2</sup>(m<sup>2</sup>).

To relieve the pressure at the seal faces, the relationship between the opening and closing forces can be controlled. If  $a_o$  is held constant and  $a_c$  is decreased by a shoulder on a sleeve or seal hardware, the seal face pressure can be lowered (see Figure 5b). This is called *seal balancing*. A seal without a shoulder in the design is referred to as an *unbalanced seal*. A balanced seal is designed to operate with a shoulder.

The ratio of the hydraulic closing area to the face area is defined as seal balance  $b$ :

$$b = \frac{a_c}{a_o}$$

Seals can be balanced for pressure at the outside diameter of the seal faces, as shown in Figure 5b. This is typical for a seal mounted inside the seal chamber. Seals installed outside the seal chamber can be balanced for pressure at the inside diameter of the seal faces. In special cases, seals can be double-balanced for pressure at both the outside and inside diameters of the seal. Seal balances can range from 0.65 to 1.35, depending on operating conditions.

**Face Pressure** As relative motion takes place between the seal planes, a liquid film develops. The generation of this film is believed to be the result of surface waviness in the individual sealing planes. Pressure and thermal distortion, as well as anti-rotation devices such as drive pins, keys, or dents used in the seal design, have an influence on surface waviness and on how the film develops between the sliding surfaces. Hydraulic pressure develops in the seal face, which tends to separate the sealing planes. The pressure distribution, referred to as a pressure wedge, shown in Figure 6, can be considered as linear, concave, or convex. The actual face pressure  $p_f$  in lb/in<sup>2</sup> (N/m<sup>2</sup>) is the sum of the hydraulic pressure  $p_h$  and the spring pressure  $P_{sp}$  designed into the mechanical seal. The face pressure  $P_f$  is a further refinement of  $P'_f$ , which does not take into account the liquid film pressure or the mechanical load of the seal:

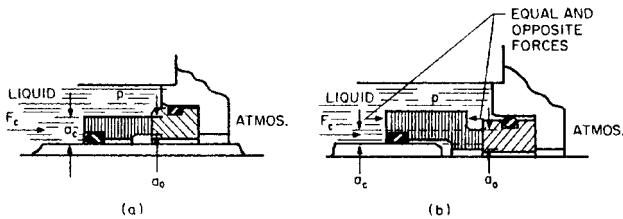


FIGURE 5 Hydraulic pressure acting on the primary ring: a) unbalanced, b) balanced

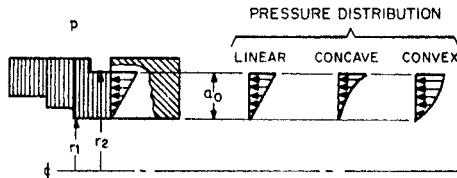


FIGURE 6 The pressure distribution can be considered linear, concave, or convex.

$$P_f = P_h + P_{sp}$$

where  $P_h = \Delta p(b - k)$ , lb/in<sup>2</sup>(N/m<sup>2</sup>) and

$\Delta p$  = pressure differential across seal face, lb/in<sup>2</sup> (N/m<sup>2</sup>)

$k$  = pressure gradient factor

$b$  = seal balance

The mechanical pressure for a seal design is

$$P_{sp} = \frac{F_{sp}}{a_o}, \text{ lb/in}^2 \text{ (N/m}^2\text{)}$$

where  $F_{sp}$  = seal spring load, lb (N) and

$a_o$  = seal face area, in<sup>2</sup> (m<sup>2</sup>)

Then the actual face pressure can be expressed as

$$P_f = \Delta p(b - k) + P_{sp}$$

The actual face pressure is used in the estimate of the operating pressure and velocity for a given seal installation.

**Pressure-Velocity** As the sealing planes move relative to each other, they are affected by the actual face pressure and rotational speed. The product of the two, pressure times velocity, is referred to as  $PV$  and is defined as the power  $N_f$  per unit area with a coefficient of friction of unity:

$$PV = \frac{N_f}{a_o}$$

For seals, the equation for  $PV$  can be written as follows:

$$PV = P_f V_m = [\Delta p(b - k) + P_{sp}] V_m$$

where  $V_m$  = velocity at the mean face diameter  $d_m$ , ft/min (m/s).

The  $PV$  for a given seal installation can be compared with values developed by seal manufacturers as a measure of adhesive wear.

**Power Consumption** The  $PV$  value also enables the seal user to estimate the power loss at the seal with the following equation:

$$N_f = (PV) f a_o, \text{ ft} \cdot \text{lb/min (N} \cdot \text{m/s)}$$

where  $f$  is the coefficient of friction.

As a rule of thumb, the power to start a seal is generally five times the running value. The coefficients of friction for various common seal face materials are given in Table 1. These coefficients were developed with water as a lubricant at an operating  $PV$  value of 100,000 lb/in<sup>2</sup> · ft/min (35.03 bar · m/s). The coefficient of friction is a function of the tribological properties of the mating pairs of seal face materials and the fluid being sealed. Values in oil would be slightly higher because of the viscous shear of the fluid film at the seal faces. For a double or tandem seal, the barrier/buffer oil should have a low viscosity and be a good lubricant. The values given are suitable for estimating the power loss in a seal.

For example, let's say we have a pump having a 2-in (50.8-mm) diameter sleeve at the seal chamber is fitted with a balanced seal of this size and mean diameter. The seal operates in water at 300 lb/in<sup>2</sup> (20.68 bar), 3,600 rpm, and ambient temperatures. The materials of construction are carbon and tungsten carbide. Determine the  $PV$  value and power loss of the seal, given the following:

**TABLE 1** Coefficient of friction for various seal face materials (John Crane Inc.)

Sliding Materials		Coefficient of friction
Rotating	Stationary	
Carbon-graphite (resin filled)	Cast iron	0.07
	Ceramic	0.07
	Tungsten carbide	0.07
	Silicon carbide	0.02
	Silicon carbide converted carbon	0.015
Silicon carbide	Tungsten carbide	0.05
Silicon carbide	Silicon carbide converted carbon	0.04
	Silicon carbide converted carbon	0.05
	Silicon carbide	0.05
	Tungsten carbide	0.01

$$\Delta p = 300 \text{ lb/in}^2 \text{ (20.68 bar)}$$

$$b = 0.75$$

$$k = 0.5$$

$$d_m = 2 \text{ in (50.8 mm)}$$

$$P_{sp} = 25 \text{ lb/in}^2 \text{ (1.72 bar)}$$

$$V_m = \frac{\pi}{12} \times 2 \times 3600 = 1885 \text{ ft}^3/\text{min} \left( \frac{\pi \times 50.8 \times 3600}{1000 \times 60} = 9.57 \text{ m}^3/\text{s} \right)$$

$$a_o = 0.4 \text{ in}^2 \text{ (0.000258 m}^2\text{)}$$

$$f = 0.07 \text{ (Table 1)}$$

In USCS units:

$$PV = [300(0.75 - 0.5) + 25](1885) = 188,400 \text{ lb/in}^2 \cdot \text{ft}^3/\text{min}$$

$$N_f = (188,400)(0.07)(0.4) = 5275 \text{ ft} \cdot \text{lb}/\text{min} = 0.16 \text{ hp}$$

In SI units:

$$PV = [20,68(0.75 - 0.5) + 1.72](9.57) = 66 \text{ bar} \cdot \text{m}^3/\text{s} = 66 \times 10^5 \text{ N/m}^2 \cdot \text{m}^3/\text{s}$$

$$N_f = (66 \times 10^5)(0.07)(2.58 \times 10^{-4}) = 119 \text{ N} \cdot \text{m}/\text{s} = 119 \text{ W}$$

**Temperature Control** Controlling the temperature at the seal faces is desirable because wear is a direct function of temperature. Heat at the seal faces also causes thermal distortion, which will contribute to increased seal leakage. Many applications require some type of cooling.

The temperature of the sealing surfaces is a function of the heat generated by the seal, plus the heat gained or lost to the pumpage. The heat generated at the faces from sliding contact is the mechanical power consumption of the seal being transferred into heat. Therefore,

$$Q_s = C_a N_f = C_1 (PV f a_o)$$

where  $Q_s$  = heat input from the seal, Btu/h(W) and

$$C_1 = 0.077 \text{ for USCS units and } 1 \text{ for SI units}$$

If the heat is removed at the same rate it is produced, the temperature will not increase. If the amount of heat removed is less than that generated, the seal face temperature will

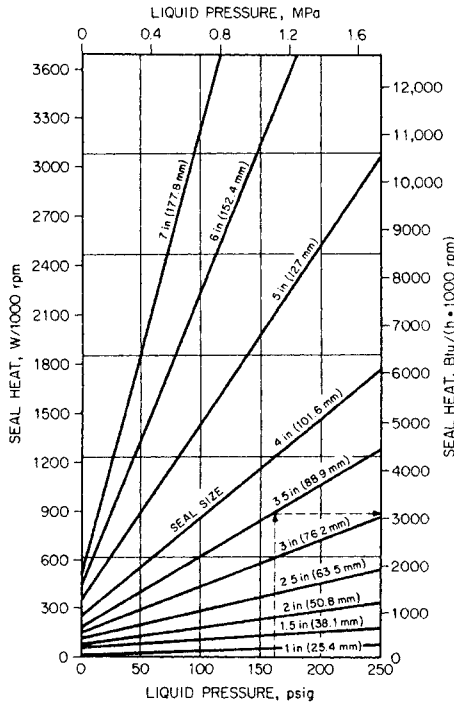


FIGURE 7 Unbalanced seal heat generation (John Crane Inc.)

increase to a point where seal face damage will occur. The estimated values for heat input are given in Figures 7 and 8.

Heat removal from a single seal is accomplished by a seal flush. The seal flush is usually a bypass from the discharge line on the pump or an injection from an external source. The flow rate for cooling can be found by calculating the following:

$$\text{gpm (m}^3/\text{h)} = \frac{Q_s}{C_2(\text{sp. ht.})(\text{sp. gr.})\Delta T}$$

where  $Q_s$  = seal heat, Btu/h(W)

$C_2$  = 500 in USCS units and 1,000 in SI units

sp. ht. = specific heat of coolant, Btu/lb. · °F (J/kg · K)

sp. gr. = specific gravity of coolant

$\Delta T$  = temperature rise, °F (K)

When handling liquids at elevated temperatures, the heat input from the process must be considered in the calculation of coolant flow. Thus,

$$Q_{net} = Q_p + Q_s$$

The heat load  $Q_p$  from the process can be determined from Figure 9.

As an example, let's determine the net heat input for a 4-in (102-mm) diameter balanced seal in water at 1,800 rpm. The pressure and temperature are 400 lb/in<sup>2</sup> (27.6 bar) and 170°F (76.7°C). From Figure 8, we have the following:

In USCS units:

$$Q_s = (3500 \text{ Btu/h/1000 rpm}) \times (1800) = 6300 \text{ Btu/h}$$

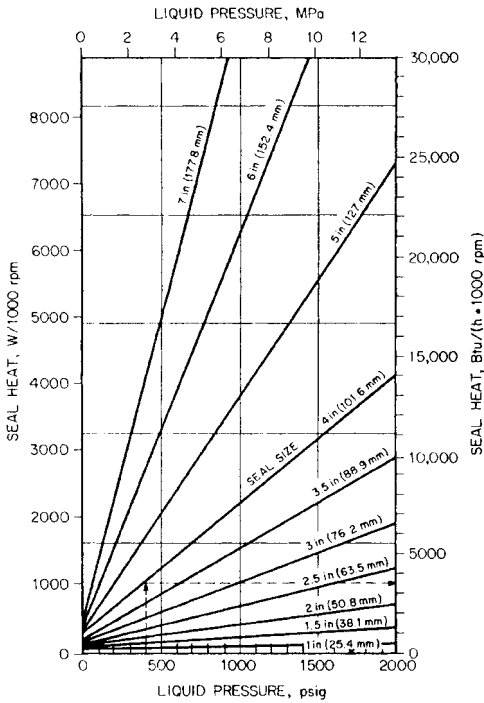


FIGURE 8 Balanced seal heat generation (John Crane Inc.)

In SI units:

$$Q_s = (1025 \text{ W}/1000 \text{ rpm}) \times (1800) = 1845 \text{ W}$$

From Figure 9, assuming that the seal chamber will be cooled to 70°F (21°C) and that the temperature difference between the seal chamber and pumpage is 100°F (37.8°C), we have the following:

In USCS units:  $Q_p = 255 \text{ Btu/h}$

In USCS units:  $Q_p = 75 \text{ W}$

$\therefore Q_{net} = 6555 \text{ Btu/h (1920 W)}$

The total heat input can be used to estimate the required flow to the seal. When multiple seals are used in a pump seal chamber, the heat load from each seal must be considered as well as any heat soak from the process.

Different methods are used to supply cool liquid to the seal chamber (see Figure 10). When the liquid is clean, an internal flush connection at (A) can be used to cool the seal. When the liquid is dirty, an external flush at (B) can be used. This will allow the flush, a bypass from the discharge line, to pass through a filter or centrifugal separator. The seal faces will be flushed with clean, cool liquid. Increased pressure from the flush provides positive circulation and prevents flashing at the seal faces caused by the heat generation.

When a pump handles liquids near their boiling point, additional cooling of the seal chamber is required. A typical arrangement to accomplish this is shown in Figure 11. This seal is equipped with a pumping ring and a heat exchanger. The pumping ring acts as a miniature pump, causing the liquid to flow through the outlet piping at the top of the seal

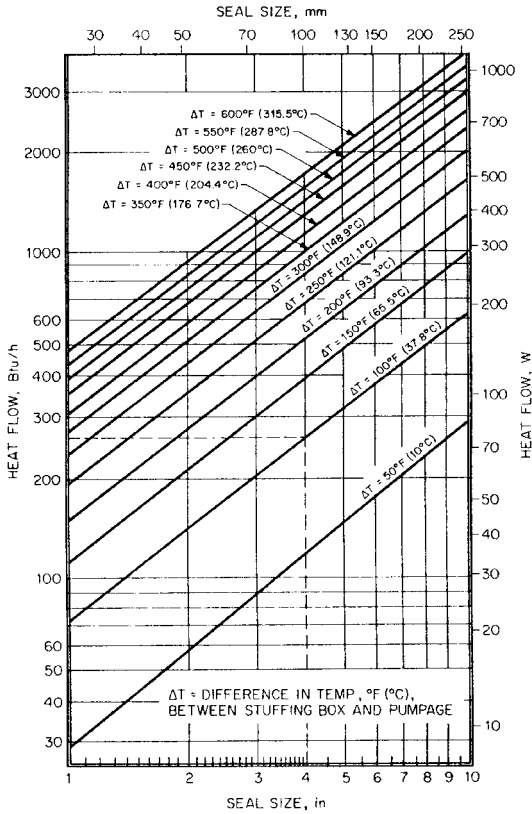


FIGURE 9 Heat soak from process when water is used for lubrication (John Crane Inc.)

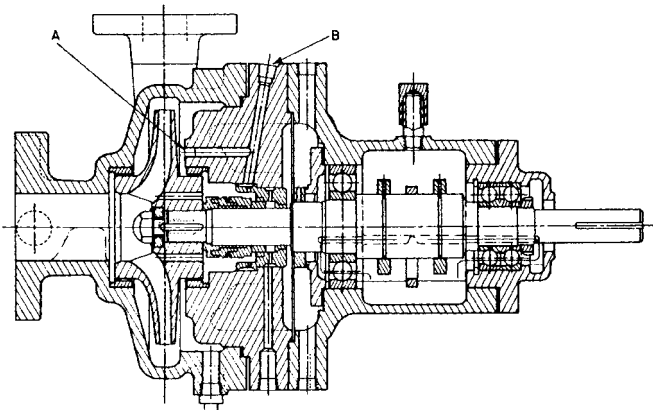


FIGURE 10 Cooling circulation to mechanical seal: (A) internal circulation plug port, (B) external circulation plug port

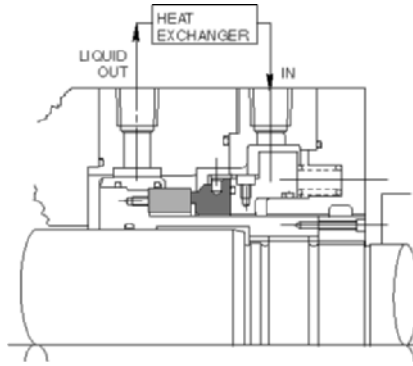


FIGURE 11 High performance boiler feed pump seal with external cooling

chamber. The liquid passes through the heat exchanger and returns directly to the faces at the bottom inlet in the end plate. As the liquid is circulated, heat is removed from the seal and seal chamber. A closed loop system is commonly used on hot water pumps. This method is extremely efficient since the coolant is circulated only in the seal chamber and does not reduce the temperature of the liquid in the pump.

It should be noted that during periods of shutdown different wear problems might exist because the seal faces may be too cold. The product being pumped may be a solution that can crystallize or solidify at ambient temperatures. For these applications, the seal faces may have to be preheated before starting to avoid damage to the seal.

**Leakage** Leakage is affected by the parallelism of the sealing planes, angular misalignment, coning (negative face rotation), thermal distortion (positive face rotation), shaft runout, axial vibration, and fluctuating pressure. For parallel faces only, which take into account seal geometry only, the theoretical leakage in cubic centimeters per hour can be estimated from the following:

$$Q_3 = -C_3 \times h^3(P_2 - P_1)/u \ln (R_2/R_1)$$

where  $C_3 = 2.13 \times 10^{10}$  in USCS units and  $1.88 \times 10^9$  in SI units

$h$  = face gap, in (m)

$P_2$  = pressure at face ID, lb/in<sup>2</sup> (N/m<sup>2</sup>)

$P_1$  = pressure at face OD, lb/in<sup>2</sup> (N/m<sup>2</sup>)

$u$  = dynamic viscosity,  $C_p$  (N · s/m<sup>2</sup>)

$R_2$  = outer face radius, in (m)

$R_1$  = inner face radius, in (m)

Negative leakage indicates flow from the face's outer diameter to the inner diameter. The effect of centrifugal force from one of the rotating sealing planes is very small and can be neglected in normal pump applications. The gap between the seal face is a function of the materials of construction, flatness, and the liquid being sealed. The face gap can range from  $20 \times 10^{-6}$  to  $50 \times 10^{-6}$  in ( $0.508 \times 10^{-6}$  to  $1.27 \times 10^{-6}$  m).

**Contacting Seal Operating Envelope** Every seal has an operating envelope. The basic envelope for a contacting seal is shown in Figure 12. The upper limits are defined by wear of the seal faces, usually defined by a pressure-velocity limit. The fluid being sealed should be cooled so the liquid at the seal faces does not flash. Operating within the envelope will result in excellent seal performance.



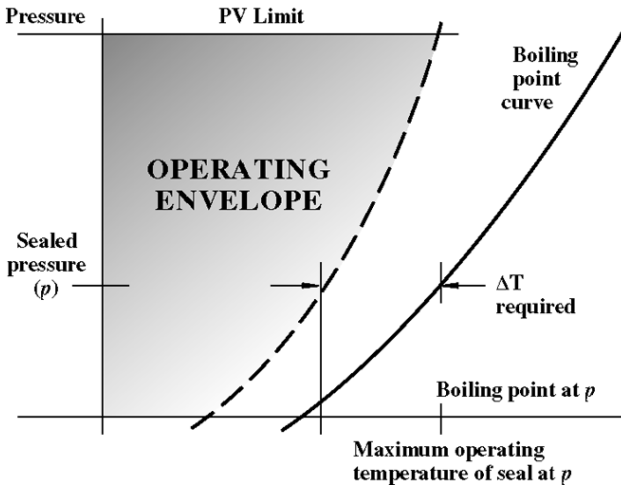


FIGURE 12 Operating envelope for a contacting seal

## CLASSIFICATION OF SEALS BY ARRANGEMENT

Sealing arrangements can be classified into two groups:

1. Single seal installations
  - a. Internally mounted
  - b. Externally mounted
2. Multiple seal installations
  - a. Double seals
  - b. Tandem seals

*Single seals* are used in most applications. This is the simplest seal arrangement with the least number of parts. An installation can be referred to as *inside-mounted* or *outside-mounted*, depending on whether the seal is mounted inside or outside the seal chamber (see Figure 13). The most common installation is an inside-mounted seal. Here the liquid under pressure acts with the spring load to keep the seal faces in contact.

Outside-mounted seals are considered to be used for low-pressure applications since both seal faces, the primary ring and mating ring, are put in tension. This limits the pressure capability of the seal. An external seal installation is used to minimize corrosion that might occur if the metal parts of the seal were directly exposed to the liquid being sealed.

*Multiple seals* are used in applications requiring

- A neutral liquid for lubrication
- Improved corrosion resistance
- A buffered area for plant safety

Double seals consist of two single seals back to back, with the primary rings facing in opposite directions in the seal chamber. The neutral liquid, at a pressure higher than that of the liquid being pumped, lubricates the seal faces (see Figure 14). The inboard seal keeps the liquid being pumped from entering the seal chamber. Both inboard and outboard seals prevent the loss of neutral lubricating liquid.

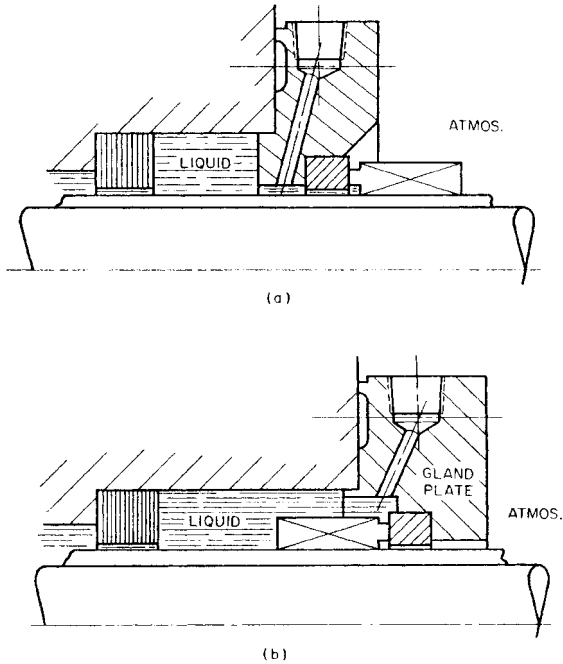


FIGURE 13 Single seal installations: a) outside mounted, b) inside mounted

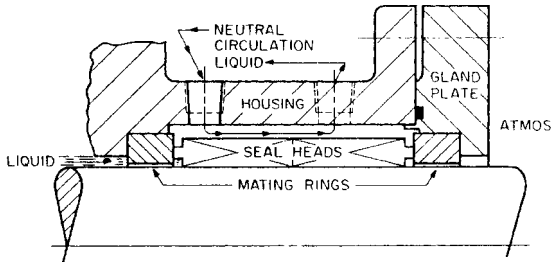


FIGURE 14 Double Seals

Double seals can be used in an opposed arrangement. Two seals are mounted face to face, with the primary sealing rings rotating on a common mating ring (see Figure 15). In this case, the neutral liquid is circulated between the seals at a pressure lower than that of the process fluid. This pressure is limited since the outboard seal faces are in tension. The inboard seal is similar to a single inside-mounted seal and carries the full differential pressure of the seal chamber to the neutral liquid. The outboard seal carries only the pressure of the neutral liquid to the atmosphere. The purpose of this arrangement is to fit a seal installation having a shorter axial length than is possible with back-to-back double seals and still form a buffered area for plant safety.

Tandem seals are arranged with two single seals mounted in the same direction (see Figure 16). The outboard seal and neutral liquid create a buffer zone between the liquid being pumped and the atmosphere. Normally, the pressure differential from the liquid

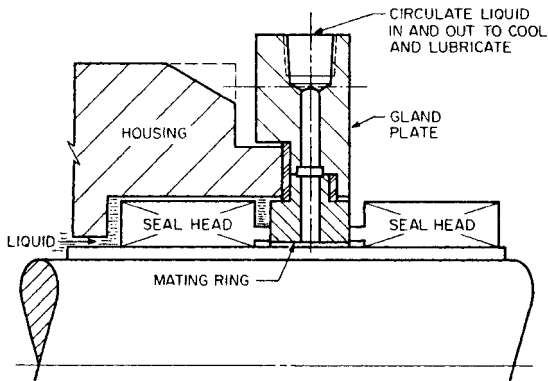


FIGURE 15 Opposed double seals

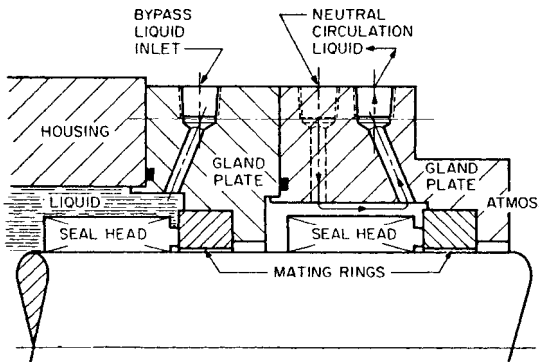


FIGURE 16 Tandem seals

being sealed and atmosphere is taken across the inboard seal, while the neutral lubricating liquid is at atmosphere pressure. This arrangement can also be used as a method to break down the pressure on high-pressure applications. For example, the pressure difference across each seal can be half the fluid pressure being sealed. The liquid in the outboard seal chamber may be circulated to remove seal heat. Tandem seals are used on toxic or flammable liquids, which require a buffered or safety zone.

Package or cartridge seals are an extension of other seal arrangements. A package seal requires no special measurements prior to seal installation. For a single seal, the seal package consists of the gland plate, sleeve, and drive collar (see Figure 17). A spacer is provided on most package seals to properly set the seal faces. The spacer is removed after the drive collar has been locked to the shaft and the gland plate bolted to the pump.

### CLASSIFICATION OF SEALS BY DESIGN

There are four seal classification groups:

- Unbalanced or balanced
- Rotating or stationary seal head

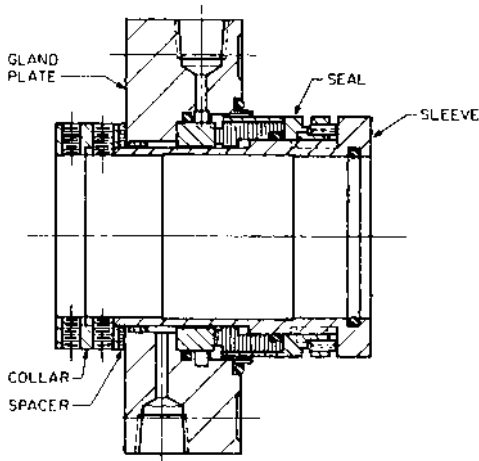


FIGURE 17 A single package (cartridge) seal assembly (John Crane Inc.)

- Single-spring or multiple-spring construction
- Pusher or nonpusher secondary seal design

The selection of an unbalanced or balanced seal is determined by the pressure in the seal chamber. Balance is a way of controlling the contact pressure between the seal faces and power generated by the seal. When the percentage of balance  $b$  (the ratio of hydraulic closing area to seal face area) is 100 percent or greater, the seal is referred to as unbalanced. When the percentage of balance for a seal is less than 100 (1.0), the seal is balanced. Figure 18 illustrates common unbalanced and balanced seals.

The selection of a rotating or stationary seal is determined by the speed of the pump shaft. A seal that rotates with the shaft is a rotating seal assembly. Typical rotating seals are shown in Figures 17, 21 and 22. When the mating ring rotates with the shaft, the seal is stationary (see Figure 19). Rotating seal heads are common in the industry for normal pump shaft speeds. As a rule of thumb, when the shaft speed exceeds 5,000 ft/min (25.4 m/s), stationary seals are required. Higher speed applications require a rotating mating ring to keep unbalanced forces, which may result in seal vibration, to a minimum. A stationary seal should be considered for all split case pumps. This will eliminate seal problems that occur when the top and bottom halves of the pump casing do not line up. The pressure in the pump can cause a misalignment of these parts that creates an out-of-square condition at the seal faces.

The selection of a single-spring or multiple-spring seal head construction is determined by the space limits and the liquid sealed. Single-spring seals are most often used with bellows seals to load the seal faces (see Figure 20a). The advantage of this type of construction is that the openness of design makes the spring a nonclogging component of the seal assembly. The coils are made of a large diameter spring wire and therefore can withstand a great deal of corrosion.

Multiple-spring seals require a shorter axial space. Face loading is accomplished by a combination of springs placed about the circumference of the shaft (refer to Figure 1 and see Figure 20b). Most multiple-spring designs are used with assemblies having O-rings or wedges as secondary seals.

Pusher-type seals are defined as seal assemblies in which the secondary seal is moved along the shaft by the mechanical load of the seal and the hydraulic pressure in the seal chamber. The designation applies to seals that use an O-ring, wedge, or V-ring. A typical construction is illustrated in Figure 21.

The primary ring, with a hardened metal surface, rotates with the shaft and is held against the stationary ring by the compression ring through loading of the O-ring. The

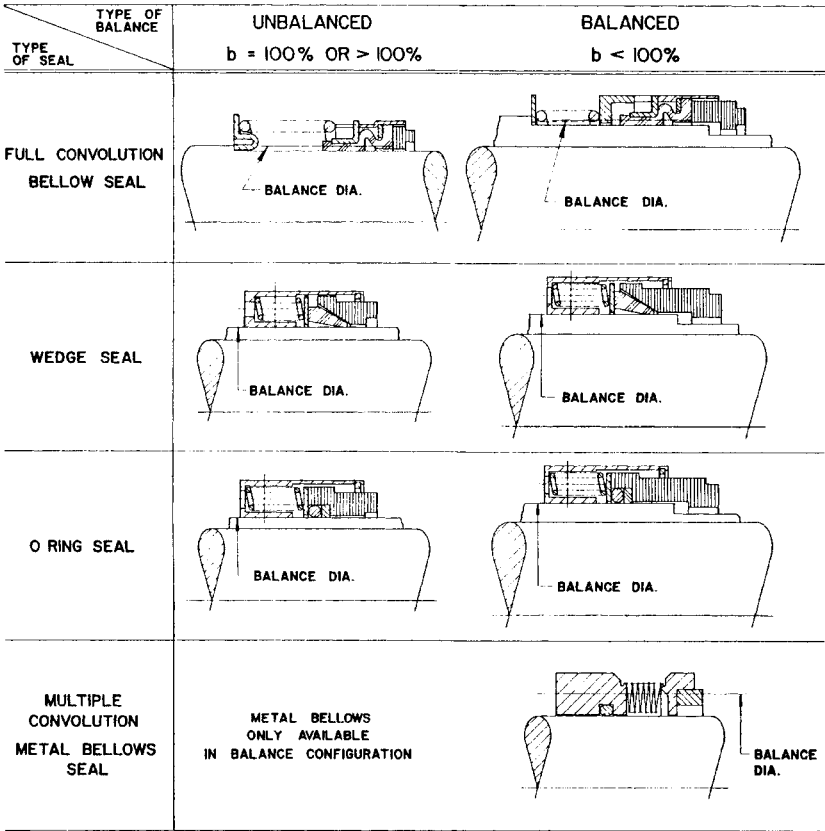


FIGURE 18 Common unbalanced and balanced seals

compression ring supports a nest of springs that is connected at the opposite end by a collar, which is fixed to the shaft. The primary ring is flexibly mounted to take up any shaft deflection or equipment vibration. The collar is fixed to the shaft by setscrews.

Another pusher-type seal is illustrated in Figure 22. When elastomers cannot be used in the product, a wedge made of TFE must be considered. A metal retainer locked to the shaft by (A) provides a positive drive through the shaft and to the primary ring (F) through drive dents (D), which fit corresponding grooves. The seal between the primary ring and shaft or sleeve is made by a wedge (E), which is preloaded by multiple springs (B). The spring load is distributed uniformly by a metal disc (C). The primary ring (G) contacts the mating ring (H) to form the dynamic seal.

Pusher seals also come in split designs. Illustrated in Figure 23 is a split seal design for an ANSI pump. This is a fully split seal design with all of the basic parts fitted outside the seal chamber. The gland plate is fully split and provides easy access to other seal components. A finger spring located on the atmospheric side of the seal provides an axial load and drive to the stationary primary ring. Since it is located on the atmospheric side of the seal, it will not be clogged from material in the pumpage. This is suited for a variety of applications, including paper stock, sewage, slurries, and river water. Two flush ports in the gland plate provide for a seal flush for cooling.

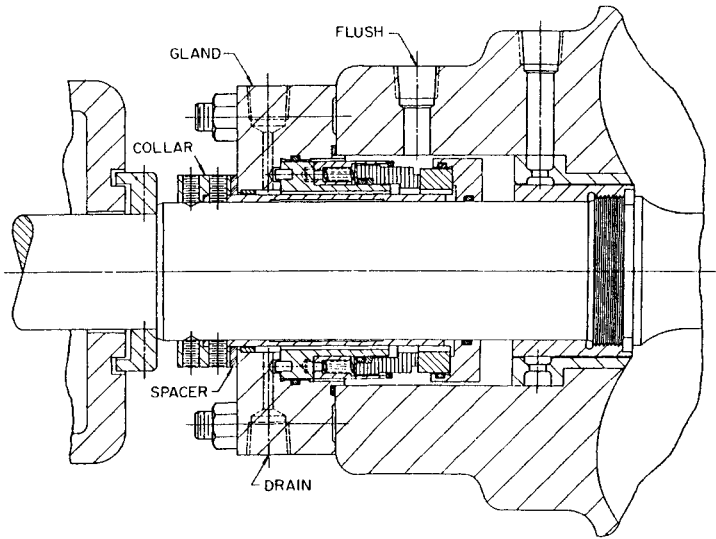


FIGURE 19 Stationary seal with a rotating mating ring (John Crane Inc.)

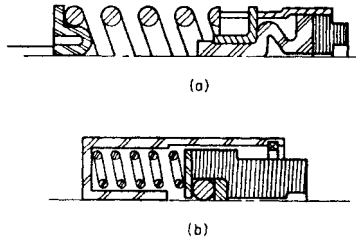


FIGURE 20 Comparison of a) single-spring and b) multiple-spring seals

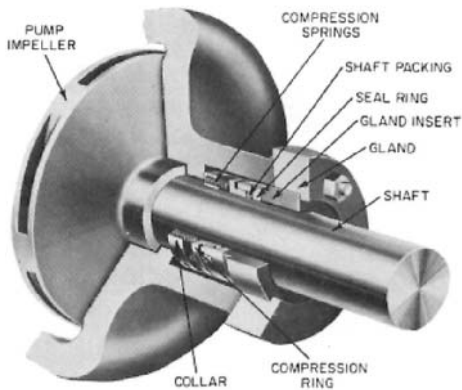
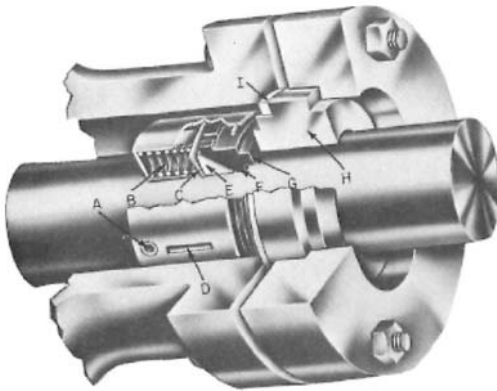
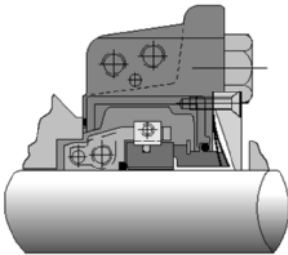


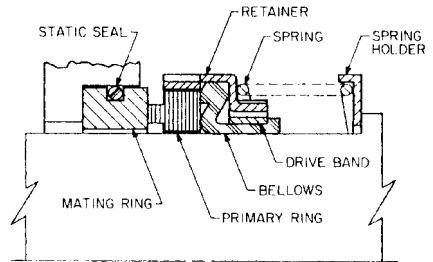
FIGURE 21 O-ring type mechanical seal (Flowsolve Corp.)



**FIGURE 22** Wedge-type mechanical seal (John Crane Inc.)



**FIGURE 23** A split seal design for an ANSI pump (John Crane Inc.)



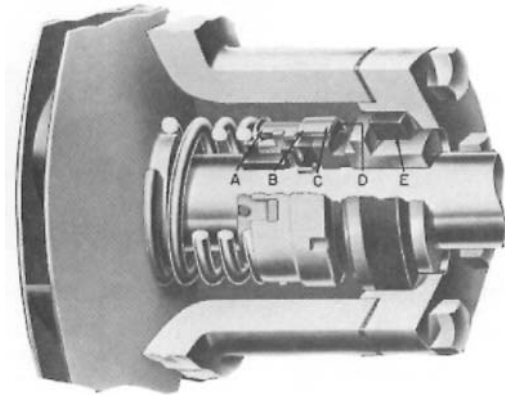
**FIGURE 24** A half-convolution bellows seal (John Crane Inc.)

Nonpusher seals are defined as seal assemblies in which the secondary seal is not forced along the shaft by the mechanical load or hydraulic pressure in the seal chamber. Instead, all movement is taken up by the bellows convolution. This definition applies to those seals that use half-, full-, and multiple-convolution bellows as a secondary seal.

The half-convolution bellows seals are always made of an elastomer (see Figure 24). The tail of the bellows is held to the shaft by a drive band. This squeeze fit seals the shaft and enables the unit to rotate with the shaft. Positive drive is accomplished through the drive band, retainer, and primary ring by a series of slots and dents. A static seal is created at the back of the primary ring and at the front of the bellows. This type of seal is used for light-duty service conditions. The amount of axial travel along the shaft is half that of a full convolution bellows.

The full-convolution bellows seal is illustrated in Figure 25. The tail of the bellows is held to the shaft by a drive band. The squeeze fit seals the shaft and enables the unit to rotate with the shaft. The drive for the seal assembly is similar to that of the half-convolution seal. Static sealing is accomplished at the front of the bellows and the back of the primary ring. The heavier full-convolution bellows design can tolerate greater shaft motion and runout to pressures of 1200 lb/in<sup>2</sup> (8.3 bar).

Multiple-convolution bellows seals are necessary to add flexibility to those secondary seal materials that cannot be used in any other shape. The mechanical characteristics of TFE and metals require multiple-convolution designs.



**FIGURE 25** A full-convolution bellows seal (John Crane Inc.)

A TFE bellows assembly is illustrated in Figure 26. Because of the large cross-sectional area, these types of seals are mounted outside the seal chamber. Pressure at the inside diameter of the seal helps keep the faces closed. Small springs on the atmosphere side of the seal supply the mechanical load to keep the seal faces closed initially.

Multiple convolution metal bellows seals come in various designs and are discussed in the following section.

### **SEALING REQUIREMENTS IN THE PETROLEUM REFINING INDUSTRY**

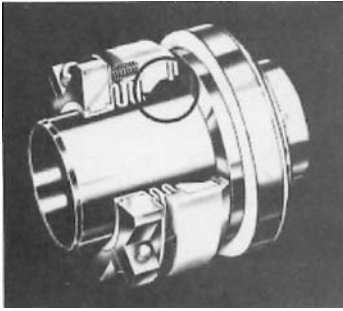
The API Standard 682 is an industrial standard developed by users with input from equipment and seal manufacturers. The goal of the standard was to create a specification for seals that would have a good probability of meeting emission standards defined by the U.S. Clean Air Act of 1990 and have a life of at least three years. The implementation of this specification indicates not only an increase in emissions control, but also a major increase in equipment reliability.

The following contacting, liquid-lubricated seal designs were identified by API 682, 1st edition (October 1994) as solutions to sealing refinery services. These have been verified by seal manufacturer tests under simulated refinery conditions. These are as follows:

- **Type A** A single, pusher-type seal mounted inside the seal chamber with a rotating flexible element. This is a balanced cartridge design with multiple springs and an O-ring as a secondary seal (see Figure 27). This seal is preferred for all refinery services except non-flashing hydrocarbons above 300°F (150°C). It is considered to be the standard for temperatures up to 500°F (265°C).
- **Type B** A single, low-temperature, non-pusher, inside-mounted seal, with a rotating metal bellows flexible element. The secondary static seals for this nickel alloy metal bellows design are fluorocarbon elastomer O-rings. This low-temperature seal design is a standard optional selection for non-flashing hydrocarbon services up to 300°F (150°C).
- **Type C** A single, high-temperature, non-pusher, inside-mounted seal with a stationary metal bellows flexible element. The secondary static seals for this high-temperature bellows design are flexible graphite. This seal is the standard selection for non-flashing hydrocarbon applications when temperatures are above 300°F (150°C) and pressures are less than 250 lb/in<sup>2</sup> absolute (17 bar).

Each of the previous seal types is also available as a dual seal arrangement (see Figure 30). When the space between the inboard and outboard seals is pressurized with a barrier fluid, the seal arrangement is referred to as a pressurized dual seal. When the





**FIGURE 26** A Teflon bellows seal (John Crane Inc.)



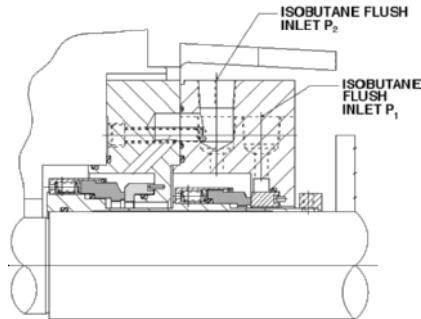
**FIGURE 27** Type A Single mounted pusher seal (John Crane Inc.)



**FIGURE 28** Type B Single inside mounted non-pusher seal (John Crane Inc.)

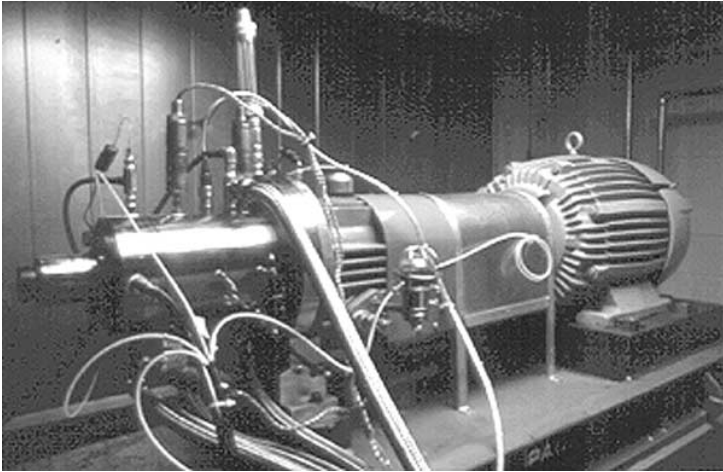


**FIGURE 29** Type C Single inside mounted high temperature seal (John Crane Inc.)



**FIGURE 30** Pressurized dual API 682 seal for HF alkylatin service (John Crane Inc.)

space between the inboard and outboard seals is unpressurized with a buffer fluid, the seal arrangement is referred to as a nonpressurized dual seal. This is the only seal cartridge that can function as a double or tandem seal with the same individual seal parts. The terms *barrier fluid* and *buffer fluid* refer to the same fluid lubricating the seal. When the fluid is pressurized, it is a barrier fluid. When the fluid is non-pressurized, it is a buffer fluid.



**FIGURE 31** API 682 qualification test rig (John Crane Inc.)

The dual seal design shown in Figure 30 is without a pumping ring on the outside diameter of the outboard seal. This figure also represents a successful installation on an HF alkylation unit. In this design, isobutane is circulated at a pressure greater than at the pressure at the outside diameter of the inboard seal. The isobutane is then flushed over the inboard seal to keep the hydrofluoric acid away from the inboard seal. Seal life has been significantly increased with this improved sealing technology.

API 682 requires qualification testing for all seal designs by the seal manufacturer. To meet these requirements, seal manufacturers constructed new testing facilities that allow testing at simulated refinery conditions for common process fluids. Figure 31 shows an API qualification test rig with instrumentation installed. Each seal type from each seal application group is required to be tested in four different test fluids that model fluids that model fluids from the application groups. These fluids include water, propane, 20 percent NaOH solution, and mineral oil. Each qualification test for each test fluid consists of three phases:

- a. the dynamic phase at constant temperature, pressure, and speed
- b. the static phase at 0 rpm using the same temperature and pressure as the dynamic phase
- c. the cyclic phase at varying temperatures and pressures, including start-ups and shut-downs. For flashing hydrocarbons, the cyclic test phase includes excursions into vapor and back to liquid.

The seal is expected to perform within the regulated emissions limits after being exposed to qualification testing and upset conditions and demonstrate a capability of at least three years life in service. The result of this effort is not only an improvement in emissions control but also a major improvement in seal reliability. This naturally results in substantially lower life-cycle cost for the user.

The success or failure of a seal installation can often be traced to the selection of the proper piping arrangement. A piping arrangement or plan defines how a seal installation will be cooled or, in some cases, heated. Commonly used systems have been defined by API and are shown in Figure 32.

Performance testing to qualify seal designs to API 682 has resulted in an improved seal flush required for cooling. The mating ring, chamfered at the outside diameter, enables the flow of the flush liquid not only around the circumferential groove, but also directly to the

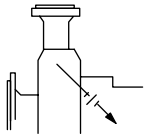
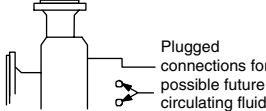
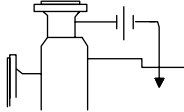
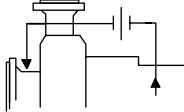
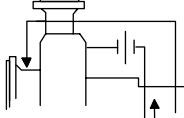
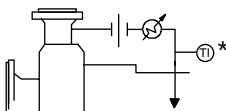
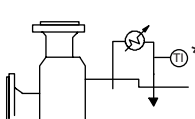
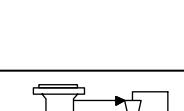
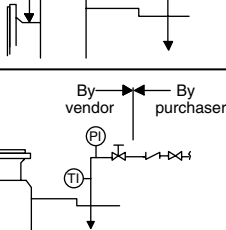
<p><b>PLAN 01</b></p> 	<p>Fluid being pumped is circulated internally from discharge to seal chamber. Internal recirculation must be sufficient to maintain stable conditions at the seal face. Recommended for clean pumpage only and horizontal pumps. Not recommended for vertical pumps.</p>
<p><b>PLAN 02</b></p> 	<p>Dead-ended seal chamber with no circulation of a seal flush fluid. Used on special applications with horizontal pumps. Not recommended for vertical pumps.</p>
<p><b>PLAN 11</b></p> 	<p>Fluid pumped is circulated externally from discharge to seal chamber. An orifice may be used to control flow. The flow enters the seal chamber adjacent to the mechanical seal faces. This flow must be sufficient to maintain stable conditions at the seal faces. Not recommended on vertical pumps.</p>
<p><b>PLAN 13</b></p> 	<p>Fluid pumped is circulated from the seal chamber back to pump suction. An orifice may be used to control flow.</p>
<p><b>PLAN 14</b></p> 	<p>Fluid pumped is circulated from discharge to the seal chamber and back to the suction nozzle. An orifice, as shown, may be used to control flow, and must be sized in accordance with the throat bushing and the return line. Similar to Plan 11, flow back to suction side will evacuate vapor that may collect in the seal chamber. Recommended for vaporizing liquid such as those found in light hydrocarbon services.</p>
<p><b>PLAN 21</b></p> 	<p>Fluid pumped is circulated from discharge through a heat exchanger and into the seal chamber. An orifice, as shown, may be used to control flow. A dial thermometer (*) may be used in the recirculation line.</p>
<p><b>PLAN 23</b></p> 	<p>Fluid pumped is moved from the seal chamber by a pumping ring through a heat exchanger and back to the seal chamber. This plan can be used on hot applications to minimize heat load on the heat exchanger by cooling only the small amount of liquid that is recirculated. A dial thermometer (*) may be used in the recirculation line. Plan 21 Fluid pumped is circulated from discharge through a heat exchanger and into the seal chamber. An orifice, as shown, may be used to control flow. A dial thermometer (*) may be used in the recirculation line.</p>
<p><b>PLAN 31</b></p> 	<p>Fluid pumped is circulated from discharge through a heat exchanger and into the seal chamber. An orifice, as shown, may be used to control flow. A dial thermometer (*) may be used in the recirculation line.</p>
<p><b>PLAN 32</b></p> 	<p>A fluid separate from the pumpage is injected into the seal chamber from an external source. Care must be exercised in selecting an external fluid for injection to provide good lubrication to the seal and eliminate the potential for vaporization and also to avoid contamination of the pumpage with the injected flush. A dial thermometer (*) and flow indicator (*) are optional.</p>

FIGURE 32 Piping plans for mechanical seals

<p><b>PLAN 41</b></p>	<p>When a hot fluid is pumped which contains suspended abrasive particles, flow from the discharge to a cyclone separator delivers clean flow to the seal chamber through a heat exchanger. An orifice, as shown, may be used to control flow. Solids are delivered to pump suction. Clean discharge to the seal chamber and dirty discharge to pump suction must be at equal pressures. A dial thermometer (*) may be used in the flush line to seals.</p>
<p><b>PLAN 52</b></p>	<p>Applies to an outer seal of an unpressurized dual seal arrangement. An external reservoir provides a buffer fluid which is circulated by an internal pumping ring in the outboard seal cavity during normal operation. The reservoir is usually continuously vented to a vapor recovery system which is maintained at a pressure less than the pressure in the seal chamber. A pressure switch (*) and heat exchanger (*) are optional.</p>
<p><b>PLAN 53</b></p>	<p>Applies to an outer seal of a pressurized dual seal arrangement. An external reservoir provides a barrier fluid under pressure which is circulated by an internal pumping ring in the outboard seal cavity during normal operation. Reservoir pressure is greater than the process pressure. A pressure switch (*) and heat exchanger (*) are optional.</p>
<p><b>PLAN 54</b></p>	<p>An outboard seal chamber is pressurized by a barrier fluid from an external reservoir. Circulation is by an external pressure system or pump. Reservoir pressure is greater than the process pressure being sealed.</p>
<p><b>PLAN 61</b></p>	<p>Tapped connections are plugged. When used, the purchaser provides quench fluid (steam, gas, water, etc.) to an auxiliary sealing device.</p>
<p><b>PLAN 62</b></p>	<p>An external source is used to provide a quench which is required to prevent solids from building up on the atmospheric side of the seal. Typically used with a close clearance throttle bushing.</p>

**NOTE:** This table provides a quick reference to piping plans described in API Standard 610, 8th edition August 1995, for centrifugal pumps for petroleum, heavy duty chemical and gas industry. The reader is encouraged to consult this specific standard for more detailed information.

**LEGEND**

Heat exchanger	Cyclone separator	Check valve
Pressure gauge with block valve	Flow indicator	Orifice
Dial thermometer	Flow regulating valve	Level indicator
Pressure switch with block valve	Block valve	

FIGURE 32 Continued.

seal faces for cooling. This design also helps to eliminate any trapped vapor at the seal faces (see Figure 33).

## GLAND PLATE CONSTRUCTION

---

An essential component of any seal installation is the *gland plate*. The purpose of this part is to hold either the mating ring assembly or the seal head assembly, depending on whether the seal head is rotating with the shaft or stationary to the pump casing. It is also a pressure-containing component of the installation. The alignment of one of the sealing surfaces, particularly the mating ring used with a rotating seal assembly and a gland plate bushing, is dependent on the fit of the gland plate to the pump. To ensure the proper installation, the API specification requires a register fit with the inside or outside diameter of the seal chamber. The static seal on the face of the seal chamber must be completely confined. Three basic gland plate constructions are shown in Figure 34:

- A *plain* gland plate is used where seal cooling is provided internally through the pump stuffing box and where the liquid to be sealed is not considered hazardous to the plant environment and will not crystallize or carbonize at the atmospheric side of the seal.
- A *flush* gland plate is used where internal cooling is not available. Here coolant (liquid sealed or liquid from an external source) is directed to the seal faces where the seal heat is generated.
- A *flush-and-quench* gland plate is required on those applications that need direct cooling as well as a quench fluid at the atmospheric side of the seal. The purpose of the quench fluid, which may be a liquid, gas, or steam, is to prevent the buildup of any carbonized or crystallized material along the shaft. When properly applied, a seal quench can increase the life of a seal installation by eliminating the loss of seal flexibility due to hangup. This gland plate can also be used for flush, vent, and drain where seal leakage needs to be controlled. Flammable vapors leaking from the seal can be vented to a flare and burned off, while nonflammable liquid leakage can be directed to a safe sump.

Figure 35 illustrates some restrictive devices used in the gland plate when quench or vent-and-drain connections are used. These bushings can be pressed in place, as in Figure 35a, or allowed to float as in Figures 35b, c, and d. Floating bushings enable closer running clearances with the shaft because such bushings are not restricted at their outside diameter. The bushing shown in Figure 35d is also split to enable the thermal expansion of the shaft. This restrictive bushing is preferred on refinery applications. Small packing rings can also be used for a seal quench, as shown in Figure 35e.

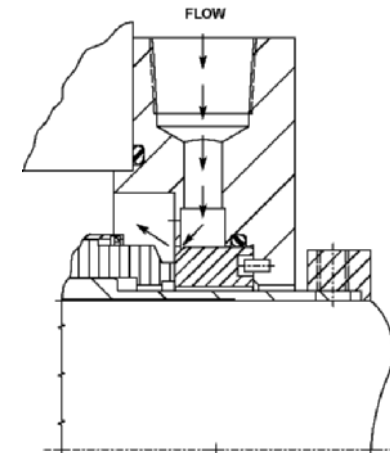
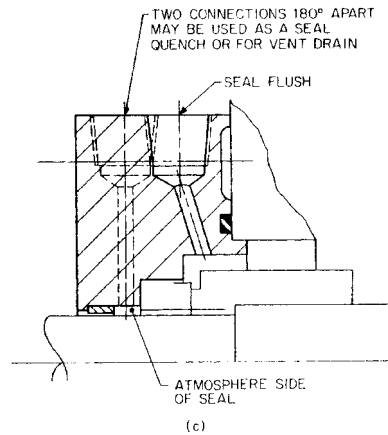
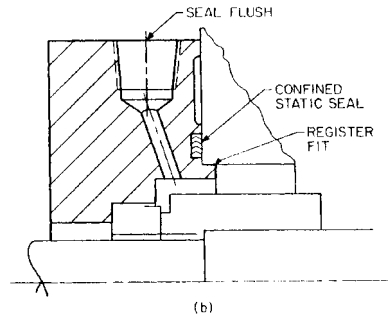
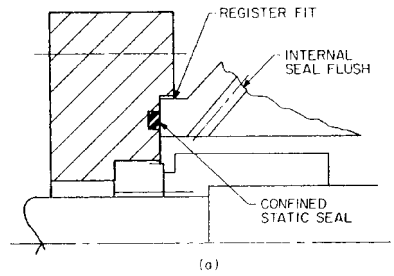
## SEAL CHAMBER DESIGN

---

A critical part of the sealing system is the seal chamber design. The selection of the proper seal chamber can increase the life of the mechanical seal. Changes in pump design have resulted in three chambers, as shown in Figure 36. These are the conventional seal chambers, referred to as the standard bore, the enlarged bore, and the tapered bore. Seal chambers can influence the seal environment through pressure, solids handling, vapor removal, and temperature. A standard bore seal chamber was originally designed for packing and has a restriction at the bottom of the chamber that limits the interchange of fluids between the chamber and pumpage. This seal chamber is dependent on the application of the proper piping plan to remove heat or abrasives.

The enlarged bore is similar to a standard bore, enabling the installation of large seal cross-sections and dual seals. The increased cross-section increases the volume of the liquid for cooling. This seal is also dependent on the proper piping plan to remove heat.

The tapered bore seal chamber has increased radial clearance and the bottom of the chamber is exposed to the impeller. The walls of the chamber promote self-venting during shutdown and self-draining during disassembly. Internal flow within the chamber elimi-



**FIGURE 33** Improved seal flush for refinery services (John Crane Inc.)

**FIGURE 34** Basic gland plate designs: (a) plain gland plate, (b) flush gland plate, (c) flush and quench, or flush vent and drain gland plate

nates the need for external piping for cooling. For some applications, operating at a higher pressure will require an external flush.

### **NON-CONTACTING GAS LUBRICATED SEALS**

The evolution of this sealing concept for pumps has its origin in gas sealing technology developed for gas compressors in the mid-1970s. The development of this technology for

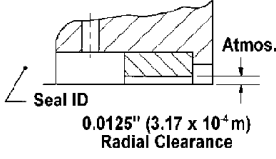
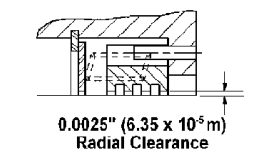
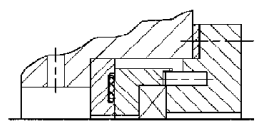
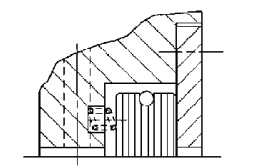
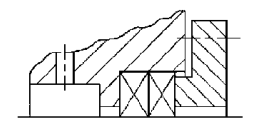
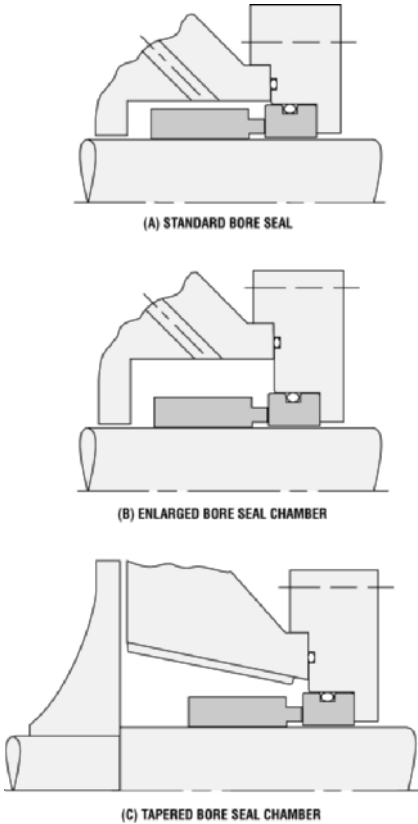
DESCRIPTION		COMMENTS
(a)  <b>Throttle Bushing</b>	 <p>Seal ID 0.0125" (3.17 x 10<sup>-4</sup> m) Radial Clearance</p> <p>Atmos.</p>	Used on vent and drain designs. Made of non-sparking materials. Meets API specifications.
(b)  <b>Floating Throttle Bushing</b>	 <p>0.0025" (6.35 x 10<sup>-5</sup> m) Radial Clearance</p> <p>Atmos.</p>	May be used on quench, vent and drain glands. Spring-loaded to float with shaft. Made of non-sparking materials. Meets API specification. Requires more space than fixed bushing.
(c)  <b>Floating Bushing</b>	 <p>Atmos.</p>	Soft packing sized to shaft diameter used on quench. Vent and drain glands. Spring loaded. No adjustments required. Excellent dry run.
(d)  <b>Split Floating Bushing</b>	 <p>Atmos.</p>	May be used on quench, vent and drain glands. Spring-loaded to float with shaft. Split carbon bushing to take into account shaft expansion due to temperature preferred for API application.
(e)  <b>Packing Rings</b>	 <p>Atmos.</p>	Creates positive seal on quench designs. Requires some adjustment during operation.

FIGURE 35 Common restrictive devices used with quench, or vent and drain gland plates.

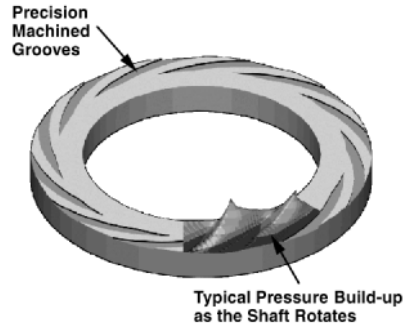
pumps was accelerated in the early 1990s as a way to control emissions. Eliminating the contact between the seal faces while the pump shaft is turning also eliminates the tribological problems of frictional heat and wear. This is no easy task with a liquid present in the pump. Deflections of the seal faces from temperature and pressure must be controlled to very precise levels. Gas, rather than a liquid, must be used as a barrier fluid and one of the seal faces must be designed with a lift mechanism.

A lift mechanism can take the shape of a spiral groove, an L-shaped slot, or a controlled wavy surface. When the shaft turns, pressure builds up in the seal faces, which causes the face separation. The basic construction of a spiral groove face and the pressure buildup is shown in Figure 37. The separation of the face is very small and could be measured in nanometers, which enables a small amount of gas to flow across the seal face. Since this type of seal is non-contacting, the only heat that is developed is from the shearing of gas at the seal faces. The small amount of gas flow helps cool the seal faces. The temperature rise at the seal faces is just a few degrees, making this a preferred seal for heat-sensitive liquids. The processes occurring at the seal faces are shown in Figure 38.

The operating envelope for a non-contacting, gas-lubricated seal for liquid pumping services is shown in Figure 39. Since the rubbing contact at the seal faces has been elim-



**FIGURE 36** Standard bore, enlarged bore, and tapered bore seal chamber arrangements.



**FIGURE 37** Spiral groove seal face and pressure build up in the grooves (John Crane Inc.)

inated, the seal can be operated at the vapor pressure of the liquid being sealed. In addition, no limiting factor exists due to the pressure-velocity relationship and wear at the seal faces. The limiting factor in the application of the seal is the pressure that has an effect on seal face deflection.

Dual pressurized, gas-lubricated seals have been designed to fit oversized and small bore seal chambers. An oversized seal chamber that enables a larger cross-section seal and that can handle pressures up to 600 psig (40 bar) is illustrated in Figure 40. Many existing pumps in the field have small bore seal chambers and do not require the same pressure capability as a larger cross-section seal. The seal to fit these units is illustrated in Figure 41. This type of seal is being used to pressures of 230 psig (16 bar).

Dual seals are pressurized with an inert gas. Gas pressure is normally 20 to 30 psig (1.4 to 2 bar) above the process liquid being sealed. The amount of gas consumed through a dual seal can be estimated from Figure 42. The gas consumption is the sum of the flow across the inboard and outboard seals. The amount of gas consumed on an annual basis is very small. This makes this type of installation very economical when compared to a fully pressurized liquid barrier/buffer system. Gas pressure and flow are monitored by a safety gas panel like that shown in Figure 43.

This technology represents a solution for those sealing problems that affect the cooling and lubrication of a contacting seal by the liquid being sealed. These problems, identified



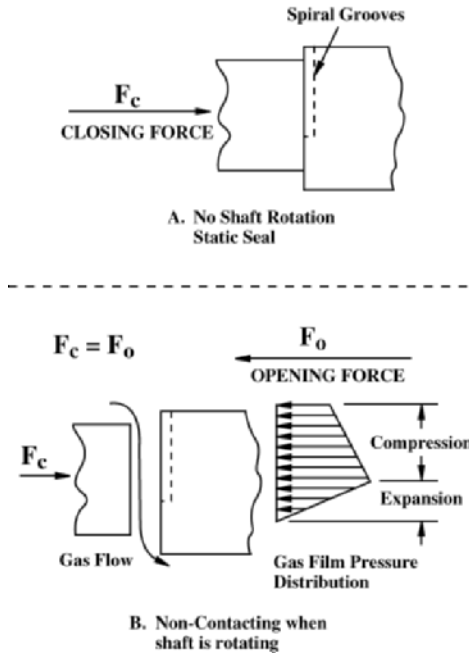


FIGURE 38 The processes occurring at the seal faces

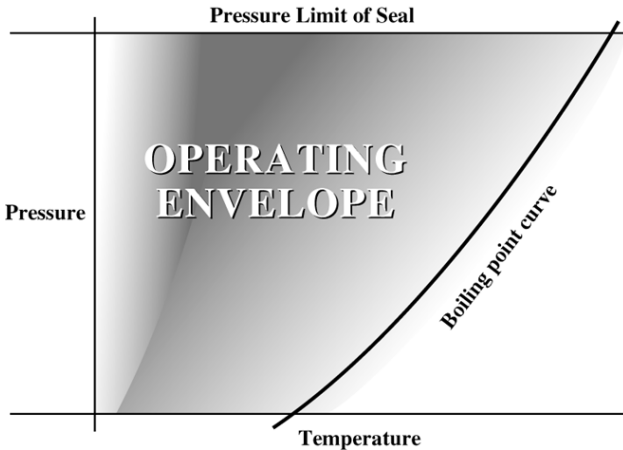
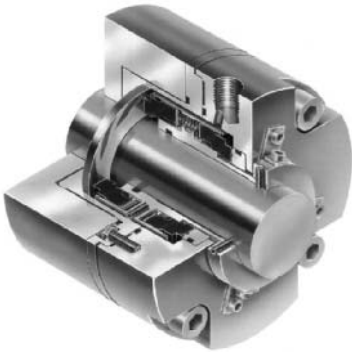


FIGURE 39 The operating envelope for a non-contacting, gas-lubricated seal for liquid pumping services. (John Crane Inc.)

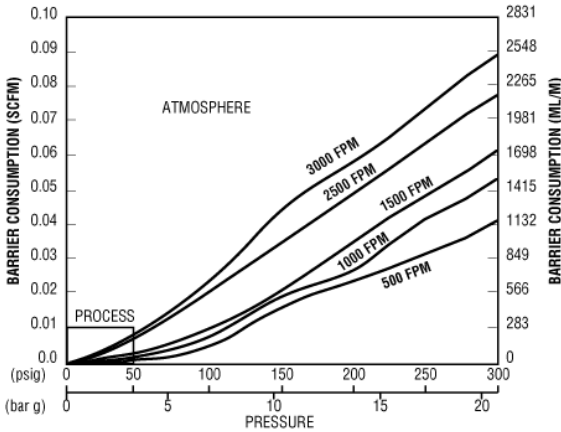
by users as reasons for a short seal life, include a loss of seal flush, dry running, startup without venting, *low net positive suction head* (NPSH), and cavitation. Cavitation may also result in vibration of the equipment. The vibration limit for a non-contacting gas lubricated seal is 0.4 in/s (10 mm/s). The benefits of this technology are increased performance, emissions control, safety, reliability, and efficiency for a conventional pump fitted



**FIGURE 40** Non-contacting gas-lubricated seal for pumps with a large bore seal chamber (John Crane Inc.)



**FIGURE 41** Non-contacting gas-lubricated seal for pumps with a small cross-section seal chamber (John Crane Inc.)



**FIGURE 42** Gas consumption through a seal face. (John Crane Inc.)

with non-contacting gas lubricated seals. This translates into increased *mean time between maintenance* (MTBM) and reduced costs of ownership of the equipment. An inert gas, such as nitrogen, is a preferred barrier fluid in refinery and petrochemical industries, while purified air is used in the pharmaceutical and biotech industries. Protecting the environment is the main reason for the development of this technology, but, it is also a primary sealing system used to maintain product purity in the pharmaceutical and biotech industries.

Pumping liquid near its vapor pressure represents a challenge to equipment manufacturers and plant operators. Trying to seal this type of application with a contacting seal will result in an inefficient installation. The amount of heat generated would require too much cooling to prevent the liquid from flashing. The only solution is to eliminate the heat generated at the seal faces, allowing the liquid being sealed to flash to a gas and use a non-contacting gas lubricated seal.

For those liquids that are dangerous to the environment, a tandem seal arrangement would be used. The space between the seals would be vented to a flare or vapor disposal

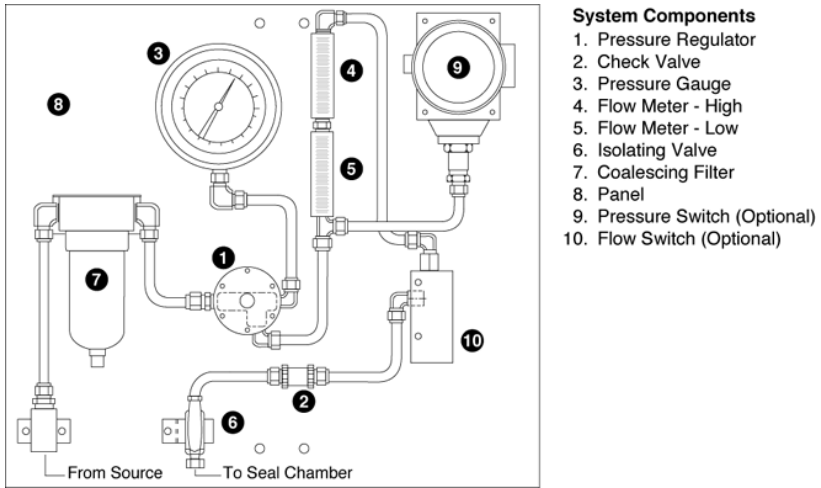


FIGURE 43 A safety gas panel for monitoring gas pressure and flow (John Crane Inc.)

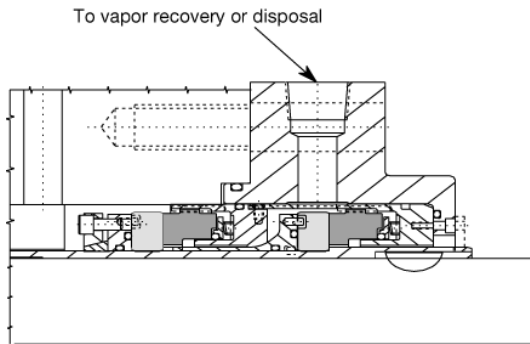


FIGURE 44 Early non-contacting gas-lubricated seal design for vaporizing hydrocarbon service (John Crane Inc.)

TABLE 2 Typical vaporizing hydrocarbon services (John Crane Inc.)

Operating Condition/ Seal Size (in)	Liquid	Pressure (lb/in <sup>2</sup> )	Temperature (Degree F) Min/Max	Speed (rpm)
1.250	Ethane	554	+45 / +125	3,560
1.875	LNG	327	+37 / +125	3,560
2.875	LNG	400	+30 / +125	3,560
3.375	Ethane	392	-49 / +125	1,750
5.250	LNG	850	+30 / +125	3,560

area. Figure 44 represents an early tandem seal arrangement for this type of service. Applying this technology to pumps has resulted in a significant increase in equipment reliability. A list of typical applications for non-contacting gas seals to be applied to vaporizing hydrocarbon liquid services is shown in Table 2.

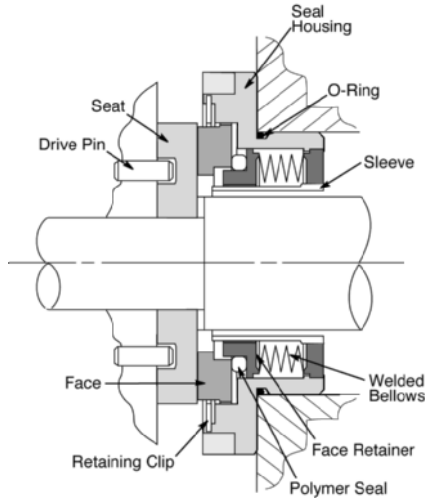


FIGURE 45 A non-contacting gas-lubricated seal for cryogenic service (John Crane Inc.)

Cryogenic liquids represent a similar design challenge in sealing technology. Traditionally, pumps that are used to pump these liquids relied on contacting seal designs. Although these fluids were at cryogenic temperatures, the seals were operating near the boiling point of the liquid. Frictional heat was enough to vaporize or flash the liquid to a gas. This resulted in short seal life. By allowing the liquid to flash to a gas and by using non-contacting gas lubricated seals, seal life has been extended from weeks to years. A non-contacting gas lubricated cryogenic seal is illustrated in Figure 45. Due to the low temperatures involved, a metal bellows is required in the seal design.

## MATERIALS OF CONSTRUCTION

All component parts of a seal are selected based on their corrosion resistance to the liquid being sealed. The *National Association of Corrosion Engineers* (NACE) Corrosion Handbook provides corrosion rates for many materials of construction for mechanical seals used with a variety of liquids and gases. When the corrosion rate is greater than two mils (0.05 mm) per year, double seals that keep the hardware items of the seal in a neutral liquid should be selected to reduce corrosion. In this design, only the inside diameter of the mating ring, the primary ring, and the secondary seal are exposed to the corrosive liquid and should be constructed of corrosion-resistant materials, such as ceramic, carbon, and Teflon. Common materials of construction are given in Table 3. Table 4 lists the properties of common seal face materials.

The operating temperature is a primary consideration in the design of the secondary and static seals in the assembly. These parts must retain their flexibility throughout the life of the seal, as flexibility is necessary to retain the liquid at the secondary seal as well as to enable a degree of freedom for the primary ring to follow the mating ring. The usable temperature limits for common secondary and static seal materials are given in Table 5.

An additional consideration in the selection of the primary and mating ring materials in sliding contact is their *PV* limitation. This value is an indication of how well the material combination will resist adhesive wear, which is the dominant wear in mechanical seals. Limiting *PV* values for various face combinations are given in Table 6. Each limiting value has been developed for a wear rate that provides an equivalent seal life of two years. A *PV* value for an individual application can be compared with the limiting *PV*

**TABLE 3** Common materials of construction for mechanical seals

Components	Materials of Construction
Secondary Seals:	
O-rings	Nitrile, Ethylene Propylene, Chloroprene, Fluoroelastomer, Perfluoroelastomer
Bellows	Nitrile, Ethylene Propylene, Chloroprene, Fluoroelastomer
Wedge or U Cups	Fluorocarbon
Metal Bellows	Stainless steel, Nickel-base Alloy
Primary Ring	Carbon, Metal-filled Carbon, Tungsten Carbide, Silicon Carbide, Siliconized Carbon, Bronze
Hardware (retainer, disc, snap rings, set screws, springs)	Stainless Steel, Nickel-base Alloy
Mating Ring	Ceramic, Cast Iron, Tungsten Carbide, Silicon Carbide

value for the materials used to determine satisfactory service. These values apply to aqueous solutions at 120°F (49°C). For lubricating liquids such as oil, values of 60 percent or higher can be used. Higher or lower values of *PV* may apply, depending on the seal face design.

### **INSTALLING THE SEAL AND IDENTIFYING CAUSES OF SEAL LEAKAGE** \_\_\_\_\_

A successful seal installation requires operation of the pump within the manufacturer's specification. Relative movement between the seal parts or shaft sleeve usually indicates that mechanical motion has been transmitted to the seal parts from misalignment (angular or parallel), endplay, or radial runout of the pump (see Figure 46).

Angular misalignment results when the mating ring is not square with the shaft and will cause excessive movement of internal seal parts as the primary ring follows the out-of-square mating ring. This movement will fret the sleeve or seal hardware on pusher type seal designs. Angular misalignment may also occur from a seal chamber that has been distorted by piping strain developed at operating temperatures. Damage in the wearing rings can also be found here if the pump seal chamber has been distorted.

Parallel misalignment results when the seal chamber is not properly aligned with the rest of the pump. No seal problems will occur unless the shaft strikes the inside diameter of the mating ring. If damage has occurred, there will also be damage to the bushing at the bottom of the seal chamber at the same location as the mating ring.

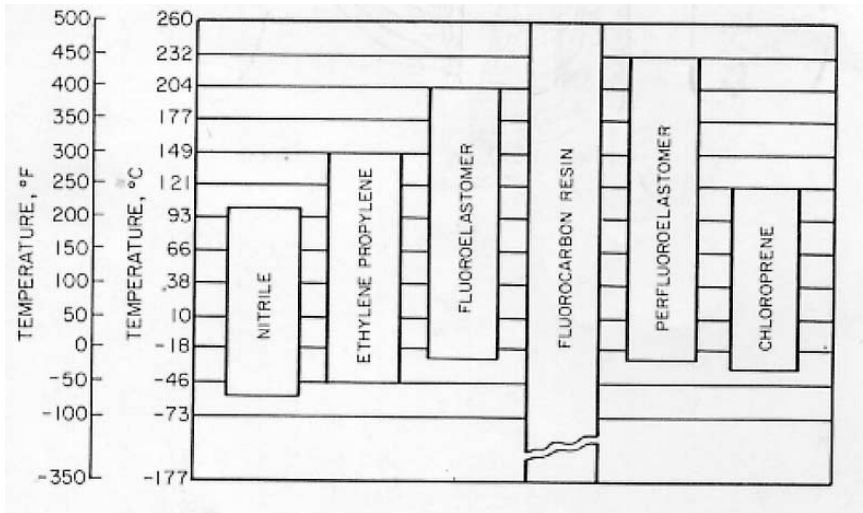
Excessive axial endplay can damage the seal surfaces and cause fretting. If the seal is continually being loaded and unloaded, abrasives can penetrate the seal faces and cause premature wear of the primary and mating rings. Thermal damage in the form of heat checking in the seal faces because of excessive endplay can occur if the seal is operated below working height.

Radial runout in excess of limits established by the pump manufacturer could cause excessive vibration at the seal. This vibration, coupled with small amounts of the other types of motion that have been defined, will shorten seal life.

Instructions and seal drawings should be reviewed to determine the installation dimension or spacing required to ensure that the seal is at its proper working height (see Figure 47). The installation reference can be determined by locating the face of the seal chamber on the surface of the sleeve and then measuring along the sleeve after it has been

**TABLE 4** Typical properties of common seal face material

Property	Cast Iron	Ni-resist	CERAMIC		CARBIDES		CARBON			
			85% (AL <sub>2</sub> O <sub>3</sub> )	99% (AL <sub>2</sub> O <sub>3</sub> )	Tungsten (6% Co)	Silicon (SiC)	Resin	Antimony	Bronze	SiC Conv.
Modulus of Elasticity × 10 <sup>6</sup> lb/in <sup>2</sup> (× 10 <sup>3</sup> Mpa)	13–15.95 (90–110)	10.5–16.9 (72–117)	32 (221)	50 (245)	90 (621)	48–57 (331–393)	2.5–4.0 (17.2–27.6)	3.8–4.8 (26.2–33.1)	2.9–4.4 (20–30)	2-2. (13.8–15.9)
Tensile Strength × 10 <sup>3</sup> lb/in <sup>2</sup> (Mpa)	65–120 (448–827)	20–45 (138–310)	20 (138)	39 (269)	123.25 (8;50)	20.65 (142)	4.5–9 (31–62)	7.5–9.0 (52–62)	7.5–9 (52–62)	2 (14)
Coefficient of Thermal Expansion × 10 <sup>-6</sup> in/in F (cm/cm K)	6.6 (11.88)	6.5–6.8 (11.7–12.24)	3.9 (7.02)	4.3 (7.74)	2.53 (4.55)	1.88 (4.55)	2.3–3.4 (4.14–6.12)	2.3–4.7 (4.14–8.46)	2.4–3.1 (4.32–5.58)	2.4–3.2 (4.32–5.76)
Thermal Conductivity Btu · ft/h · ft <sup>2</sup> °F (w/m × k)	23–29 (39.79–50.17)	25–28 (43.25–48.44)	8.5 (14.70)	14.5 (25.08)	41–48 (70.93–83.04)	41–60 (70.93–103.8)	3.8–12 (6.57–20.76)	5.8–9.0 (10.0–15.6)	8–8.5 (13.84–14.70)	30 (51.9)
Density: lb/in <sup>3</sup> (kg/m <sup>3</sup> )	0.259–0.268 (7169–7418)	0.264–0.268 (7307–7418)	0.123 (3405)	0.137 (3792)	0.50 (16.331)	0.104 (2879)	0.064–0.069 (1771–1910)	0.083–0.112 (2297–3100)	0.083–0.097 (2297–2685)	0.067–0.070 (1854–1938)
Hardness	Brinell		Rockwell A			Rockwell 45N	Shore			Rockwell 15T
	217–269	131–183	87	87	92	86–88	80–105	75–100	70–92	90

**TABLE 5** Temperature limits of secondary seal materials

removed from the unit. It is not necessary to use this procedure if a step in the sleeve or collar has been designed into the assembly to provide for proper seal setting. Assembling other parts of the seal will bring the unit to its correct working height.

All package or cartridge shaft seals can be assembled with relative ease because just the bolts at the gland plate and set screws on the drive collar need to be fastened to the seal chamber and shaft. After the seal spacer is removed, the unit is ready to operate.

To assemble a mechanical seal to a pump, a spacer coupling is required. If the pump is packed but may later be converted to mechanical seals, a spacer coupling should be included in the pump design.

Since a seal has precision-lapped faces and because secondary seal surfaces are critical in the assembly, installations to the equipment should be kept as clean as possible. All lead edges on sleeves and glands should have sufficient chamfers to facilitate installation.

When mechanical seals are properly applied, there should be no static leakage and, under normal conditions, the amount of dynamic leakage should range from none to just a few drops per minute. Under a full vacuum, a mechanical seal is used to prevent air from leaking into the pump. If excessive leakage occurs, the cause must be identified and corrected. Causes for seal leakage with possible corrections are listed in Table 7. In addition, Figure 48 illustrates the most common causes for mechanical seal leakage. Further information on seal leakage and the related condition of seal parts can be found in the works listed in the "Further Reading" section.

**TABLE 6** Frequently used seal face materials and their PV limitations

Sliding Materials		PV limit, lb/in <sup>2</sup> · ft/min (bar · m/s)	Comments
Rotating	Stationary		
Carbon-graphite	Ni-resist	100,000 (35.03)	Better thermal shock resistance than ceramic
	Ceramic (85% Al <sub>2</sub> O <sub>3</sub> )	100,000 (35.03)	Poor thermal shock resistance and much better corrosion resistance than Ni-resist
	Ceramic (99% Al <sub>2</sub> O <sub>3</sub> )	100,000 (35.03)	Better corrosion resistance than 85% Al <sub>2</sub> O <sub>3</sub> Ceramic
	Tungsten Carbide (6% Co)	500,000 (175.15)	With bronze-filled carbon graphite, PV is up to 100,000 lb/in <sup>2</sup> ft/min (35.02 bar · m/s)
	Tungsten Carbide (6% Ni)	500,000 (175.15)	Ni binder for better corrosion resistance
	Silicon Carbide (converted Carbon)	500,000 (175.15)	Good wear resistance; thin layer of SiC makes relapping questionable
	Silicon Carbide (solid)	500,000 (175.15)	Better corrosion resistance than Tungsten Carbide but poorer thermal shock resistance
Carbon-graphite		500,000 (17.51)	Low PV, but very good against face blistering
Ceramic		10,000 (3.50)	Good service on sealing paint pigments
Tungsten Carbide		120,000 (42.04)	PV is up to 185,000 lb/in <sup>2</sup> ft/min (64.8 bar · m/s) with two grades that have different % of binder
Tungsten Carbide/ Silicon Carbide (solid)		300,000 (105.1)	Excellent abrasion resistance. Commonly used on high temperature applications
Silicon Carbide (converted carbon)		500,000 (175.15)	Excellent abrasion resistance, more economical than solid Silicon Carbide
Silicon Carbide (solid)		350,000 (122.6)	Excellent abrasion resistance, good corrosion resistance and moderate thermal shock resistance



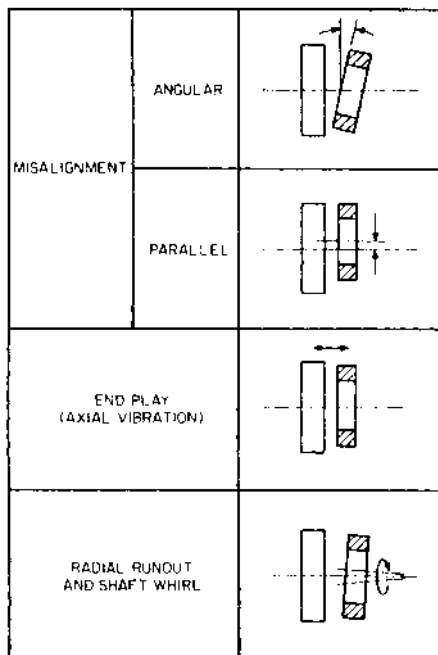


FIGURE 46 Common types of motion that influence seal performance

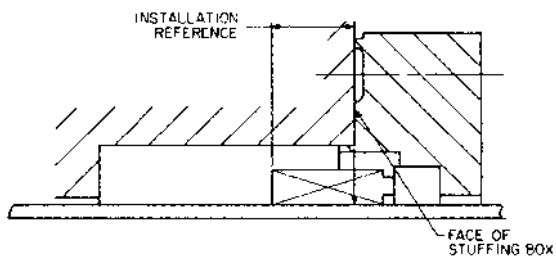


FIGURE 47 Typical installation reference dimensions

**TABLE 7** Checklist for identifying causes of seal leakage

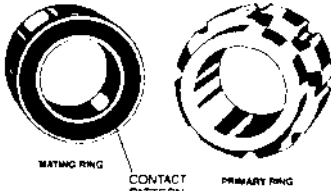
Symptom	Possible Causes	Corrective procedures
Seal spits and sputters (“face popping”) in operation	Seal fluid vaporizing at seal interfaces	Increase cooling of seal faces.
		Check for proper seal balance with seal manufacturer
		Add bypass flush line if not in use
		Enlarge bypass flush line and/or orifices in gland plate
Seal drips steadily	Faces not flat Carbon graphite seal faces blistered Seal faces thermally distorted	Check for seal interface cooling with seal manufacturer
		Check for incorrect installation dimensions
		Check for improper materials or seals for the application
		Improve cooling flush lines
		Check for gland plate distortion due to overtorquing of gland bolts
		Check gland gasket for proper compression
		Clean out foreign particles between seal faces; relap faces if necessary
		Check for cracks and chips at seal faces; replace primary and mating rings
		Replace secondary seals
		Check for proper lead-in chamfers, burrs, and so on
Secondary seals nicked or scratched during installation O-rings overaged Secondary seals hard and brittle from compression set Secondary seals soft and sticky from chemical attack	Check for proper seals with seal manufacturer	
	Check with seal manufacturer for other material	
Spring failure Hardware damaged by erosion Drive mechanisms corroded	Replace parts	
	Check with seal manufacturer for other material	

(continues)

**TABLE 7** Continued.

Symptom	Possible Causes	Corrective procedures
Seal squeals during operation	Amount of liquid inadequate to lubricate seal faces	Add bypass flush line if not in use Enlarge bypass flush line and/or orifices in gland plate
Carbon dust accumulates on outside of gland ring.	Amount of liquid inadequate to lubricate seal faces Liquid film evaporating between seal faces	Add bypass flush line if not in use Enlarge bypass flush line and/or orifices in gland plate Check for proper seal design with seal manufacturer if pressure in stuffing box is excessively high
Seal leaks	Nothing appears to be wrong	Refer to list under "Seal drips steadily" Check for squareness of stuffing box to shaft Align shaft, impeller, bearing, and so on to prevent shaft vibration and/or distortion of gland plate and/or mating ring
Seal life is short.	Abrasive fluid  Seal running too hot  Equipment mechanically out of line	Prevent abrasives from accumulating at seal faces Add bypass flush line if not in use Use abrasive separator or filter Increase cooling of seal faces Increase bypass flush line flow Check for obstructed flow in cooling lines Align Check for rubbing of seal on shaft

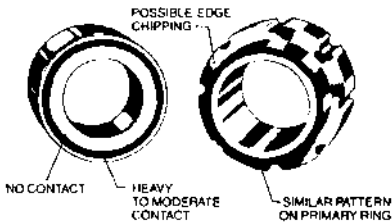
### 1. FULL CONTACT PATTERN



#### OBSERVATION:

Typical contact pattern for a non-leaking seal. Full contact on the mating ring surface through 360°. Little or no measurable wear on either seal ring. If leakage is present with this type face pattern, the secondary seals must be examined.

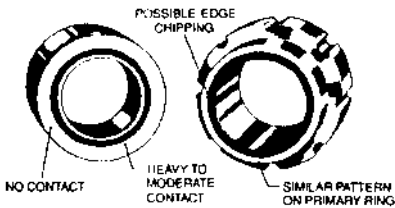
### 2. CONING (NEGATIVE ROTATION)



#### OBSERVATION:

Heavy contact on the mating ring pattern at the outside diameter of the seal. Fades away to no visible contact at the inside diameter of contact pattern. Possible edge chipping on the outside diameter of primary ring.

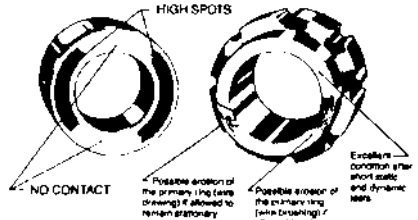
### 3. THERMAL DISTORTION (POSITIVE ROTATION)



#### OBSERVATION:

Heavy contact on the mating ring pattern at the inside diameter of the seal. Fades away to no visible contact at the outside diameter of contact pattern. Possible edge chipping on the inside diameter of the primary ring.

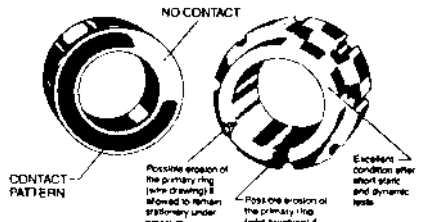
### 4. MECHANICAL DISTORTION



#### OBSERVATION:

Mating ring is distorted mechanically, creating two large contact spots. Pattern fades away between contact areas.

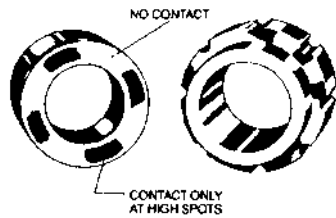
### 5. MECHANICAL DISTORTION



#### OBSERVATION:

Mating ring is being distorted mechanically, creating contact through approximately 270°. Pattern fades away at the low spot.

### 6. MECHANICAL DISTORTION

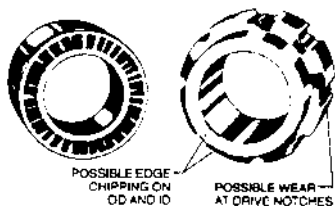


#### OBSERVATION:

Mating ring is being distorted mechanically, creating contact at both. High spots are at each contact location.

FIGURE 48 Identifying causes of seal leakage (John Crane Inc.)

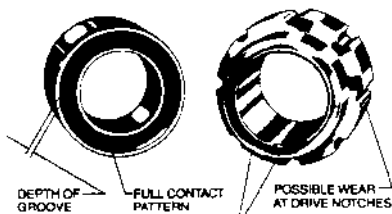
### 7. HIGH WEAR OR THERMALLY DISTRESSED SURFACE



#### OBSERVATION:

High wear of mating or thermally distressed surface (heat cracking) through 360°. High primary ring wear with carbon deposits on atmosphere side of seal. Possible edge chipping of primary ring due to opening and closing of seal faces.

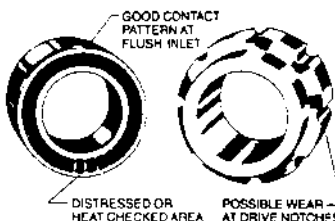
### 10. HIGH WEAR AND GROOVING



#### OBSERVATION:

High wear of the mating ring. Primary ring has grooved the mating ring evenly through 360°.

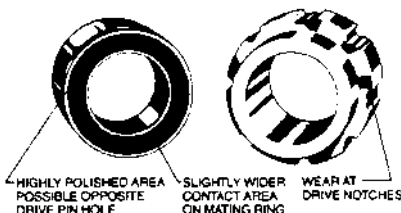
### 8. SECTION OF THERMALLY DISTRESSED SURFACE



#### OBSERVATION:

Thermally distressed area approximately 1/3 of the contact pattern. Distressed area 180° from inlet of seal flush. High primary ring wear with possible carbon deposits on atmosphere side of seal.

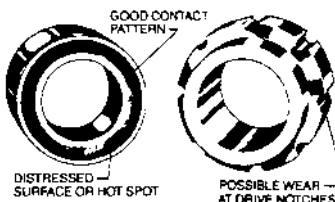
### 11. OUT-OF-SQUARE MATING RING



#### OBSERVATION:

Contact pattern through 360° slightly larger than primary ring face width. High spot may be present on the mating ring opposite a drive pin hole. Mating ring without static seals will rock or move in gland plate or holder.

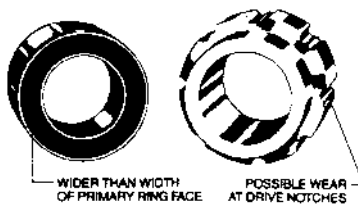
### 9. PATCHES OF THERMALLY DISTRESSED SURFACE



#### OBSERVATION:

Patches of thermally distressed surface (heat cracking). 2, 3, 4, 5 or 6 hot spots are possible. High primary ring wear with possible carbon deposits on atmosphere side of seal. Failure due to hot spots (thermal asperities); is likely to occur on light speeded gravity loads at high speeds and pressures.

### 12. WIDE CONTACT PATTERN



#### OBSERVATION:

Contact pattern considerably wider on the mating ring than the face width of the primary ring.

FIGURE 48 Continued.

## FURTHER READING

Abar, J. W. "Failures of Mechanical Face Seals." in *Metals Handbook, Vol. 10*, 8th ed., American Society for Metals. Metals Park, OH, 1975.

American Petroleum Institute. "Centrifugal Pumps for General Refinery Services." API Standard 610, 8th ed., Washington, DC, 1995.

Crane Packing Company. *Engineered Fluid Sealing: Materials, Design and Application*. Morton Grove, IL, 1979.

Crane Packing Company. *Identifying Causes of Seal Leakage, S-2031 and Bulletin*. Morton Grove, IL, 1979.

- Gabriel, R. P., and Niamathullah, S. K. "Design and Testing of Seals to Meet API 682 Requirements." Proceedings of the 13th International Pump Users Symposium, Turbomachinery Laboratory, Texas A&M University. College Station, TX, Mar. 1996.
- Ganzon, N. "Seal Chamber Design Affects Reliability, Emissions." *Pumps and Systems*. Nov. 1995.
- Hamaker, J. B. "Mechanical Seal Lubrication Systems." 1977 ASLE Education Program Fluid Sealing Course, American Society of Lubrication Engineers and Crane Packing Company. Morton Grove, IL, May 1977.
- Hamner, N. E. (compiler). *Corrosion Data Survey, 5th ed.* National Association of Corrosion Engineers. Houston, TX, 1975.
- Morrissey, C. P. "A New Shaft Sealing Solution for Small Cryogenic Pumps," 51st Annual Meeting Society of Tribologists and Lubrication Engineers. Cincinnati, OH, May 1996.
- Netzel, J. P. "Mechanical Seals for Biochemical and Sterile Processes." American Society of Mechanical Engineers, Bioprocessing Equipment Design Conference. Charlottesville, VA, October 1993.
- Netzel, J. P. "Sealing Solutions." *Plant Engineering and Maintenance*. Feb. 1991.
- Netzel, J. P. "Sealing Technology, A Control for Industrial Pollution," *Lubrication Engineering*. pp. 483-493, 1990.
- Netzel, J. P. "Surface Disturbances in Mechanical Face Seals From Thermoelastic Instability." American Society of Lubrication Engineers, 35th Annual Meeting. Anaheim, CA, May 5, 1980.
- Netzel, J., and Wray, M. "Improving Equipment Reliability in the Petroleum Refining Industry." Conference Proceedings, Methods, Strategies, and Technologies to Reduce Total Equipment Ownership Costs, Aramco Service Company. Houston, TX, Oct. 1997.
- O'Brien, A. and Wasser, J. R. "Design and Application of Dual Gas Seals for Small Bore Seal Chambers." 14th International Pump Users Symposium, Turbomachinery Laboratory, Texas A&M University. College Station, TX. Mar. 1997.
- Schoenherr, K. "Design Terminology for Mechanical Face Seals." SAE Transactions 74 (650301), 1966.
- Schoenherr, K. and Johnson, R. L. "Seal Wear." *Wear Control Handbook*. (M. Peterson and W. Winer, eds.) American Society of Mechanical Engineers. New York, 1980.
- Snapp, R. B. "Theoretical Analysis of Face Type Seals with Varying Radial Face Profiles." 64-WA/LUB 6, American Society of Mechanical Engineers. New York, 1964.
- STLE. "Guidelines for Meeting Emission Regulations for Rotating Machinery with Mechanical Seals." SP-30, Society of Tribologists and Lubrication Engineers. Park Ridge, IL, Apr. 1994.
- Wasser, J. R. "Dry Seal Technology for Rotating Equipment." 48th Annual Meeting Society of Tribologists and Lubrication Engineers. Calgary, Alberta, Canada, May 1993.
- Wasser, J. R., Sailer, R., and Warner, G. "Design and Development of Gas Lubricated Seals for Pumps." Proceeding of the Eleventh International Pump Users Symposium, Turbomachinery Laboratory, Texas A&M University. College Station, TX, March 1994.

# 2.2.4 CENTRIFUGAL PUMP INJECTION-TYPE SHAFT SEALS

ROBERT D. ASHTON  
TIMOTHY L. WOTRING

Injection-type shaft seals (sometimes called *packless stuffing boxes*) are designed to control leakage from hot-water pumps. Cool water is injected into each seal to either suppress or regulate the hot leakage, which would otherwise flash upon reaching the outside of the pump.

Injection-type shaft seals provide high reliability and yet require little maintenance. They are used primarily in power plant boiler-feed and reactor-feed pump applications where shaft peripheral speeds are high (3600 rpm and up) and pumping temperatures are greater than 250°F (120°C). Under these conditions, conventional packing or mechanical-seal-type stuffing boxes may not be suitable or desirable.

Injection shaft seals are either *serrated throttle bushings* or *floating ring seal* designs that regulate the flow, temperature, and pressure of the controlled leakage. The flow of the cool injection and of any hot water in the seals depends on operating pressures, but it is restricted by close seal clearances and is regulated by injection control valves.

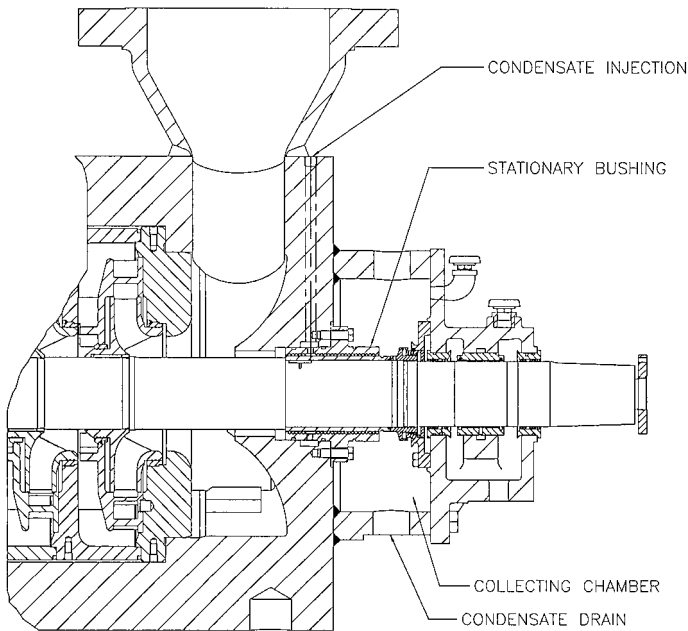
The operating temperature of the seals is controlled by allowing cool injection water to surround the outside of the seal. Ports in the seal enable the cool injection water access to the shaft to either overcome or mix with hot water in the seal so that the resulting seal leakage is cool.

The seal designs must provide sufficient pressure breakdown between the pump suction or balance device chamber pressures inside the pump and the atmospheric conditions outside the pump. Upon reaching the outside of the seal, the cool leakage is piped away by gravity drain for eventual return to the power plant feedwater system.

## **SERRATED THROTTLE BUSHINGS**

---

The construction of a serrated (sometimes called *labyrinth* or *grooved*) bushing (see Figure 1) varies from one pump manufacturer to another. However, the serrated designs basically involve a rotating shaft running with a reasonably small clearance, such as 0.002 to



**FIGURE 1** \*\*\*Author: Replacement caption was not provided\*\*\*

0.003 in per inch (0.002 to 0.003 mm per millimeter) of the shaft diameter within a solid stainless steel (typically 12 percent chrome) stationary bushing installed in the pump casing end cover. Grooved serrations are applied to the hardened stainless steel rotating surface (usually a shaft sleeve) or to the stationary bushing or to both rotating and stationary surfaces to effect a high throttling action or stuffing box leakage reduction.

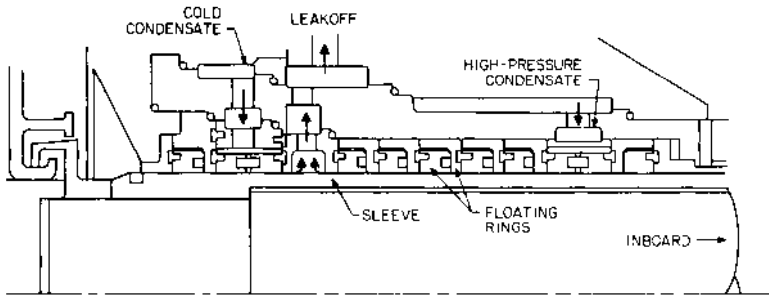
The serrations create a more effective pressure breakdown than a smooth axial surface and enable increased running clearances to let foreign particles, such as grit, pass through or flush out in the grooves. The increased clearances also enable more tolerance for any displacement between rotating and stationary components that might result from assembly misalignment or from distortions induced by transient temperatures. The grooved running surface area at clearances is greatly reduced relative to that of a smooth axial surface, and therefore possible metal surface contact between rotating and stationary parts is reduced during transient operations.

Seal leakage could be reduced by decreasing the running clearance in the injection seal, but the smaller clearance would limit the capability of the serrated seal to conform to radial shaft movement. Reduced clearances in any injection seal design may lead to problems with thermal distortions caused by a loss of available cool injection water and may also increase galling by particles trapped in the seal running fits.

### **FLOATING RING DESIGN**

A segmented throttle bushing made of many floating rings will enable conformity with the radial shaft movement and smaller running clearances to reduce seal leakage. The construction of a floating ring stuffing box (see Figure 2) varies from one pump manufacturer





**FIGURE 2** Floating ring seal design with shaft sleeve. Pegs prevent rotation of spring-loaded rings but let them float radially. (From *Power*, August 1980, McGraw-Hill, New York, copyright 1980)

to another, but the unit basically consists of a stack of hardened, martensitic stainless steel rings (typically 17 percent chrome), instead of a stationary bushing. The rings run against a smooth, hardened, martensitic stainless steel (typically 12 to 17 percent chrome) rotating shaft sleeve surface.

The separate rings are all contained within a housing installed in the pump casing end cover. Each ring is loaded against an adjacent stainless steel ring spacer so that a stationary seal is produced in the axial direction, but the ring is still able to move radially with the shaft. An axial loading of the rings is provided by hydraulic pressure during operation and by springs during idle pump periods. The rings are locked against rotation usually by pegs and/or a slot arrangement.

A small radial clearance, usually 0.001 to 0.0015 in per inch (0.001 0.0015 mm per mm) of the shaft diameter, is provided between the rings and the shaft sleeve to provide an adequate throttling of seal leakage across the limited number of seal rings. The length of each ring varies with the diameter of the injection-type seal but is generally about 0.50 in (13 mm). The radial clearance enables a reduced injection flow but increases the sensitivity of the seal to foreign particles in the seal leakage.

The individual seal rings are permitted to move radially (float), finding an equilibrium running position relative to the shaft. The capability to float up to .016 in (.4 mm) radially increases the tolerance for shaft misalignment as the shaft passes through the seal area. The multiplicity of seal rings further reduces the effect of any angular displacement between the rotating and stationary components that might arise from errors in the original assembly or from distortions caused by temperature changes during pump load variations.

Some injection-type shaft seal designs use a combination of serrations and floating rings in the same stuffing box. For either type of seal, careful maintenance during the assembly or disassembly requires accurate alignment of the rotating and stationary components as well as careful handling to avoid scratching the components. Cleanliness is of utmost importance with shaft seals.

## CONDENSATE INJECTION REQUIREMENTS

Because boiler-feed and reactor-feed pumps normally have high feedwater temperatures, 250 to 500°F (120 to 260°C), with consequent vapor pressures higher than external atmospheric conditions, the seal leakage must be cooled to avoid flashing in the stuffing box or outside the pump. This cooling is usually accomplished by injecting cold condensate from a power plant condensate pump directly into the seal to cool the stuffing box components as well as the seal leakage.

The amount of condensate injection water required will depend on several factors, including (1) whether the design is a serrated or floating ring, (2) the type of seal control

system, (3) the diameter, clearance, and rotating speed of the running fit, and (4) the internal pump pressure and temperature. A typical example of stuffing box flows would be a 5500-rpm, boiler-feed pump with a temperature-controlled seal system (described later) and a serrated 5-in (127-mm) diameter running seal with about 0.015 inches (0.38 mm) of diametrical clearance. The approximate flows would be as follows:

1. Total injection per seal: 5 to 15 gpm (0.3 to 1.0 l/s)
2. Leakage from internal pump to seal: 0 to 5 gpm (0 to 0.3 l/s)
3. Drainage from each seal: 8 to 20 gpm (0.5 to 1.3 l/s)

Given a seal with a floating ring design (having typically half the clearance of seals with a serrated bushing design), the previous conditions would require only 50 to 60 percent of the injection water needed by the serrated bushing design with the larger clearance.

During pump standby periods, higher injection and leakage flows are required because of reduced seal throttling caused by low or zero speed, by high internal pump pressures, or by a pump balance device that induces higher internal leakage during standby. The injection flows to both stuffing boxes on a multistage pump may not be the same as a result of pump balance action at one end of the pump.

Cold condensate, 85 to 110°F (30 to 45°C), is usually available from the power plant condensate pump or secondary condensate booster pump discharge. The variation in condensate supply pressure relative to internal boiler-feed pump pressure makes it necessary to use injection control systems for satisfactory seal operation.

Condensate injection systems vary to accommodate the wide range of pressures and temperatures found in different power plant feedwater system layouts. The four basic types of injection flow systems are (1) manual, (2) differential pressure-controlled, (3) differential temperature-controlled, and (4) constant drain temperature control.

**Manual System** Manual flow control requires setting and readjusting a valve by hand for each stuffing box each time a change occurs in pump operating conditions due to varying plant loads. Although it is possible to use such a control system, it is not usually recommended because of the inability to automatically compensate for rapid changing conditions.

**Differential Pressure-Controlled System** The differential pressure-controlled shaft seals operate as cold condensate maintained at a pressure greater than boiler-feed pump suction is injected into the central portion of the seal. By maintaining an injection pressure above the pump seal chamber pressure, a small portion of this injection water flows into the pump proper, and most of the injected water flows out of the seal into a collection chamber adjacent to the pump bearing bracket. The leakage in the collection chamber, which is vented to the atmosphere, is drained by gravity for an eventual return to the main feedwater system.

The differential pressure-controlled system has a pneumatic injection control valve. This valve in the condensate injection line is governed by an air signal received from a differential pressure control monitor that maintains the preset pressure differential, 10 to 25 lb/in<sup>2</sup> (70 to 170 kN/m<sup>2</sup>), between the injection pressure and the internal pump pressure. This system is not always favored, however, because of a feedback instability tendency resulting from operating pressure changes affecting the valve position, which changes pressure, and so on. Another unfavorable factor for hot-water service is the introduction of cold condensate into a hot pump at all times, including pump idle periods, affecting pump prewarming conditions.

**Differential Temperature-Controlled System** The differential temperature-controlled system operates by maintaining a seal drain temperature differential of 25°F (14°C) above the injection water temperature. The temperature differential ensures a continuous out-leakage of hot boiler feed water. The hot out-leakage is desirable, ensuring that cold water cannot be injected into the pump and thus eliminating thermal distortions that occur with the differential pressure-controlled system. The valve controllers are identical to the controllers used for the differential pressure-controlled system.

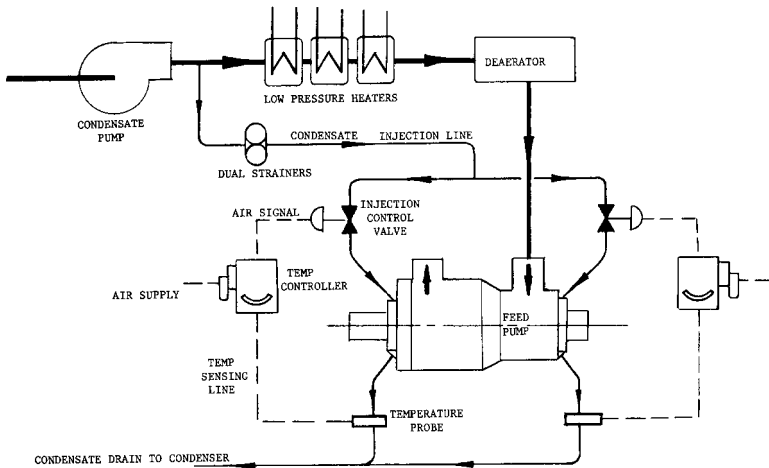


FIGURE 3 Temperature-controlled system regulating condensate injection to feed pump shaft seals

**Constant Drain Temperature-Controlled System** The constant drain temperature-controlled seal system (see Figure 3) controls hot out-leakage by throttling the injection flow to maintain a preset seal drain temperature. This system has a temperature-sensing probe in each seal drain line. Each probe is connected to an indicating temperature controller, which provides an air signal to a pneumatic control valve in the condensate injection line for control of the seal injection flow rate. Electronic control systems are often used where thermocouples or RTD's sense drain temperatures. The signal output is then processed through an I/P controller that adjusts the position of the pneumatically operated throttle valve as required.

The cold condensate is injected into the stuffing box central portion and allowed to mix with hot water entering the seal from inside the pump. The drain temperature is maintained at a preset 140 to 150°F (60 to 66°C) to preclude flashing in the stuffing box or in the drains. Note that with this system some hot water enters the seal. Therefore, cold condensate does *not* enter the hot pump and does not adversely affect pump warming conditions, especially during extended idle periods. The required condensate injection pressure is at least equal to the internal stuffing box pressure plus interim frictional loss between the condensate supply source and the point of hot-water mixture. Note that this system *may* enable satisfactory operation even when the condensate supply pressure is nearly equal to boiler-feed pump suction pressure. In addition to providing a rapid response to variations in operating pump conditions, this type of control will always supply just enough injection water to maintain the recommended drainage temperature.

**Intermediate Leakoff System** The intermediate-leakoff shaft seal system (see Figure 4) has many variations but basically uses a bleedoff from a central portion of the stuffing box. This system may be used to reduce internal stuffing box pressure if high boiler-feed pump suction pressure exists. To create a positive leakoff flow, the intermediate bleedoff flow is piped back to a plant feedwater system low-pressure point, such as a plant condenser, heater, or booster pump suction where the pressure is less than the boiler-feed pump suction pressure. However, the back pressure of the leakoff destination must be above the bleedoff vapor pressure to suppress flashing in the leakoff lines. This back pressure may be the leakoff destination pressure or may be created by an orifice or a valve.

Cold condensate injection into the stuffing box is controlled by a pressure differential monitor maintaining a preset pressure above the bleedoff pressure (refer to Figure 4). A

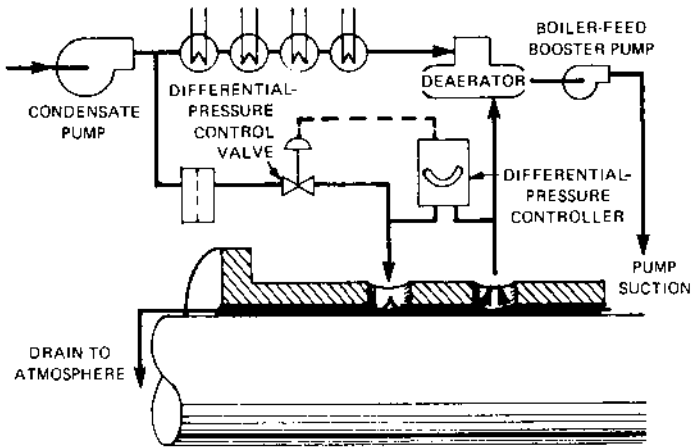


FIGURE 4 Typical intermediate-leakoff shaft seal system. (From *Power*, September 1980, McGraw-Hill, New York, copyright 1980)

stuffing box drain temperature control can also be used. Note that the cold condensate injection pressure need not equal or overcome a high feed pump suction pressure. The condensate injection temperature must still be 85 to 110°F (30 to 45°C) to keep the drain temperature below the flashing condition. Condensate injection shaft seals without an intermediate bleedoff but that are subject to suction pressures in excess of about 250 lb/in<sup>2</sup> (1725 kN/m<sup>2</sup>) must be extremely long for a proper pressure breakdown. Longer shaft seals require thicker pump case end covers, affecting pump cost, and a longer rotating element, which could adversely affect rotor dynamics. The intermediate-leakoff shaft seal is effective where there is high feed pump suction pressure imposed by boiler-feed booster pumps or in a closed feedwater system with no deaerating open heater, wherein a condensate pump discharge can be fully imposed on the feed pump at low plant loads.

In plant systems with feedwater heaters between a booster pump and a feed pump, a high pressure condensate from the cooler booster pump is injected into the seal to enable a cooler intermediate leakoff to help prevent flashing (refer to Figure 2).

## INJECTION SOURCES

Many power plant feedwater systems with deaerating direct-contact heaters (open cycle) usually have the boiler-feed pump drawing water directly from the deaerator. These open cycles with constant-speed condensate pumps always have cold condensate supply pressures in excess of boiler-feed pump suction pressure because of the increased available condensate pump head at low system flows and the interim system frictional loss at high system flows.

If a boiler-feed booster pump or a closed feedwater system with no open heaters and resultant higher boiler-feed pump suction pressures is used, the pump manufacturer may elect to require condensate injection seal water booster pumps or may use an intermediate-leakoff packless shaft seal with a condensate injection overcoming only the intermediate leakoff pressure. If the condensate pumps are variable-speed units that enable the condensate injection pressure to drop to an equal feed pump suction pressure at low loads with little or no feedwater system frictional drop, then condensate injection seal water pumps are required. In this situation, at least one pump manufacturer offers an optional pumping

ring configuration in their packless seal that can increase the seal water pressure in the stuffing box to overcome any pump suction pressure.

### AUXILIARY EQUIPMENT

---

The condensate injection piping should be conservatively sized based on the maximum injection flow requirements to obtain a low pressure drop between the injection source and the seal injection control valve. These control valves may be equipped with limit stops to prevent full closure and enable a continuous cool injection to the seals under almost all operating conditions. In some installations, isolating lines are furnished around the valves to enable a continued injection flow even during control valve maintenance. The valves can also be designed to remain open during a failure, such as a loss of station air to the pneumatic controls, and to close only with an air supply. Injection control systems that are not properly maintained might result in cold water entering a hot pump. Should this problem occur while a boiler feed pump is in the hot standby mode or when turning gears, thermal gradients will occur, leading to contact among the close running fits within the pump. Proper maintenance and operation of the injection control systems is necessary to ensure reliable operation of the pump itself. The air supply filter regulators for each control must be furnished with relatively dry clean air at station supply pressure.

The condensate injection supply to the seals must be clear and free of foreign matter to prevent damage to stuffing box components. It is therefore necessary to install filters in the injection line prior to the control valve. To keep damaging fine mill scale, oxide particles, abrasives, and other materials from entering the small seal clearances, several pump manufacturers recommend 100-mesh (150-micron) dual strainers. If dual strainers with isolating valves are used, each filter can be cleaned without interrupting injection flow during pump operation. Pressure gages should be installed before and after each filter to permit the operator to monitor filter pressure drop. A differential pressure switch and alarm for each filter are preferable to alert the operator to clean the strainer when pressure drop becomes excessive.

The condensate injection shaft seals should always be filled with cool water before and during pump operation, even during reverse pump rotation. Some pump manufacturers stipulate that condensate injection *must* be continuous without any interruption during all operation modes.

The clearances in the condensate injection shaft seal may double over the service life of the internal wearing parts. With double clearances, the leakage will approximately double. This factor should be considered when sizing the return drain piping back to the plant condenser if frictional losses are to be kept to a minimum. The drain line should be pitched at least a quarter-inch per foot (20 mm per meter). The collecting chamber at the pump stuffing box is vented to the atmosphere, and the only head available to evacuate the chamber is the static head between the pump and the point of return. This head must always be well in excess of the frictional losses (even after the leakage is doubled). Otherwise, the drains may back up, the collection chambers may overflow, and the adjacent bearing brackets may flood, with subsequent possible intrusion of water into the pump bearings and lubricating oil.

The seal collection chambers have especially large connections to assure proper drainage, provided no back pressure exists. Two types of condensate drain systems can be used to dispose of the drain coming from the collecting seal chambers. One system uses traps that are piped directly to the plant condenser if sufficient static head exists for positive drain flow. The second system collects the drain in a condensate storage tank into which various other drains (from other pumps shaft seals and so on) are also directed. As this vented storage tank is under atmospheric pressure, it must be set at a reasonable elevation below the pump centerline so that the static elevation difference will overcome frictional losses in the drain piping. A separate condensate transfer pump, under control of the storage tank liquid level control system, can then pump the condensate drains from the storage tank into the plant condenser. The storage tank should have its own overflow

protection system that enables outside drainage if, for some reason, proper drainage cannot be achieved. For example, the top of the tank vent pipe should be below the pump centerline to help preclude the possibility of drainage backing up to the level of the pump seal collection chambers. Note that this storage tank should also be large enough for an adequate drainage collection to help prevent backups.

### ***PACKLESS SHAFT SEALS WITHOUT INJECTION***

---

The packless shaft seals that have been so successfully applied to boiler-feed, reactor-feed, and booster pump services are applicable to a number of other services. For instance, they are very suitable for cold-water condensate booster pumps and for high-pressure pumps applied to hydraulic descaling or hydraulic press work. In such services, there is no need to bring in an injection supply water to the breakdown seals (unless the pumped water is not clear and free of gritty material), because the water handled by the pump is already cold with no danger of flashing as it leaves the pump stuffing boxes.

# 2.2.5 CENTRIFUGAL PUMP OIL FILM JOURNAL BEARINGS

WILBUR SHAPIRO

## *PRINCIPLES OF OPERATION*

---

A journal bearing is essentially a viscous pump, and it derives load capacity by pumping the lubricant through a small clearance region. In Figure 1, the fluid is dragged along by

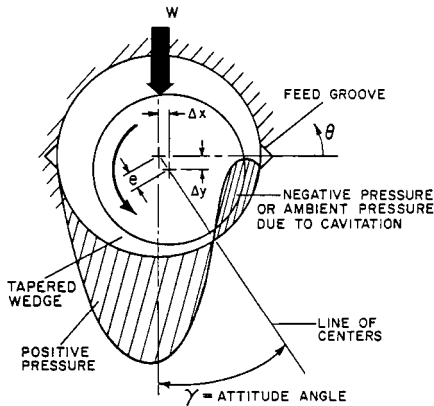


FIGURE 1 Two-groove cylindrical bearing.

the rotating journal. To generate pressure, the resistance to pumping must increase in the direction of the flow. In the figure, the journal moves to form a converging tapered clearance in the direction of the rotation or flow.

The eccentricity  $e$  is the total displacement of the journal from its concentric position. The attitude angle  $\gamma$  in Figure 1 is the angle between the load direction and the line of centers. Note that, because of the necessity to form a converging wedge, the displacement of the journal is not along a line that is coincident with the load vector. A positive pressure is produced in the converging region of the clearance. Downstream from the minimum film thickness, which occurs along the line of centers, the film becomes divergent. The resistance decreases in the direction of pumping, and either negative pressures occur or the air in the lubricant gasifies or cavitates and a region of atmospheric pressure occurs in the bearing area. This phenomenon is known as *fluid film bearing cavitation*. It should be clearly distinguished from other forms of cavitation that take place in pumps, such as in the impeller, for example. Here the fluid is traveling at a high velocity and the inertia forces on each fluid element dominate. Implosions occur in the impeller and can cause damage.

In a bearing, the viscous forces dominate and each fluid particle moves at a constant velocity in proportion to the net shearing forces on it. Thus, cavitation in a bearing is more of a change of the phase of the lubricant that occurs in a region of lower pressure that permits the release of entrained gases. Generally, bearing cavitation does not cause damage.

**Regimes of Lubrication** Whether or not a fluid film can be formed, journal rotation is dependent on several factors including the surface speed, viscosity, and load capacity. A parameter<sup>1</sup> is often used to determine a particular regime of lubrication,  $ZN/\bar{P}$ , where

$Z$  = viscosity of lubricant, cP (Pa · s)

$N$  = rotating speed, rpm

$\bar{P}$  = average pressure of the bearing, lb/in<sup>2</sup> (bar)\*

A plot of the coefficient of friction versus  $ZN/\bar{P}$  generally has the form shown in Figure 2. At low values of  $ZN/\bar{P}$ , a combination of viscosity, speed, and load places a bearing in a boundary lubricated regime where typical coefficients of friction are 0.08 to 0.14. Boundary lubrication implies intimate contact between the opposed surfaces. As the value of the parameter increases as a result of the increased speed, increased viscosity, or lowered load, there is a dramatic reduction in the coefficient of friction. In this region, there is a mixed film lubrication and the coefficient of friction varies between 0.02 and 0.08. By mixed film lubrication, it is meant that the journal is partly surrounded by a fluid film and is partly supported by rubbing contact between the opposed members. As  $ZN/\bar{P}$  increases

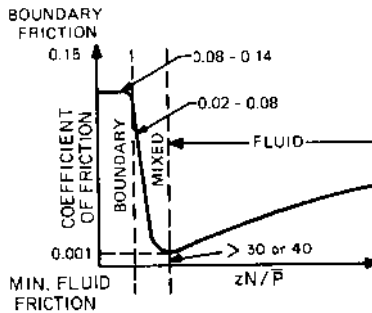


FIGURE 2 Coefficient of friction versus  $ZN/\bar{P}$  (Ref. 1).

\*1 bar =  $10^5$  Pa. For a discussion of bar, see "SI Units: A Commentary" in the front matter.



further, a situation of full fluid film lubrication prevails.

A general rule of thumb is that  $ZN/\bar{P}$  should be 30 (0.44) or greater for a fluid film to be generated. Note that as  $ZN/\bar{P}$  continues to increase beyond the full film demarcation, the coefficient of friction rises, but at a relatively low rate and generally remains in regions of low coefficients of friction.

#### EXAMPLE

$$\begin{aligned} Z &= 30 \text{ cP (0.03 Pa} \cdot \text{s)} \\ N &= 150 \text{ rpm} \\ \bar{P} &= 200 \text{ lb/in}^2 \text{ (13.6 bar)} \\ \frac{ZN}{\bar{P}} &= \frac{30 \times 150}{200} = 22.5 \end{aligned}$$

The bearing is not fluidborne and is operating in the mixed film regime. At what speed will the bearing become hydrodynamic? For hydrodynamic operations,  $ZN/\bar{P} = 30$ . Therefore,

$$N = \frac{30\bar{P}}{Z} = \frac{30 \times 200}{30} = 200 \text{ rpm}$$

## THEORETICAL FOUNDATIONS

---

The foundation of a fluid film-bearing analysis emanates from the boundary layer theory of fluid mechanics. The governing differential equation was first formulated by Osborne Reynolds in 1886 and is known as Reynolds' equation in his honor. It has been only in the last 30 years or so that general solutions have been obtained, and this has been primarily due to the use of numerical methods applied to the digital computer. References 2 and 3 go into the details of contemporary numerical solutions and are recommended for those interested in the analytical aspects of lubrication.

**Principal Assumptions** Reynolds' equation can be derived from the Navier-Stokes equation of fluid mechanics, and a number of textbooks are available that comprehensively describe the derivation.<sup>4</sup> The primary assumptions are as follows:

- Laminar flow conditions prevail, and the fluids obey a Newtonian shear stress distribution where the shear stress is proportional to the velocity gradient.
- Inertial forces, resulting from acceleration of the liquid, are small relative to the viscous shear forces and may be neglected.
- The pressure across the film is constant since the fluid films are so thin.
- The height of the fluid film is small relative to other geometric dimensions, and so the curvature of the fluid film can be ignored.
- The viscosity of the liquid remains constant. In most cases, this is a reasonable assumption since it has been repeatedly demonstrated that, if the average viscosity is used, little error is introduced and the complexity of the analysis is considerably reduced.

**Derivation of Reynold's Equation of Lubrication** Assume that the rotating journal has a peripheral velocity  $U$ . Consider an elemental volume in the clearance space of the bearing and establish equilibrium (see Figure 3). Note that since inertial forces are neglected, the volume is in equilibrium by the pressure and shear forces acting upon it, so there is no acceleration. As shown in Figure 4,  $p$  is the pressure and  $\tau$  is the shear stress acting upon the volume. Summing forces in the  $x$  direction

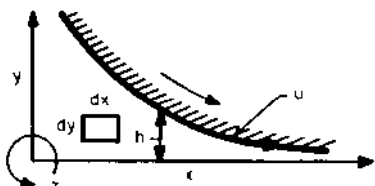


FIGURE 3 Fluid control volume.

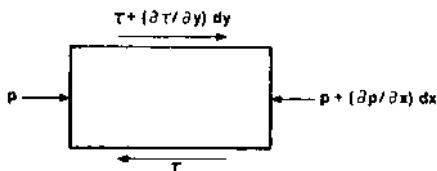


FIGURE 4 Force equilibrium on fluid element.

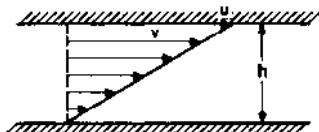


FIGURE 5 Laminar velocity distribution across film.

$$p \, dy \, dz - \left( p + \frac{\partial p}{\partial x} dx \right) dy \, dz - \tau \, dx \, dz + \left( \tau + \frac{\partial \tau}{\partial y} dy \right) dx \, dz = 0 \quad (1)$$

$$- \frac{\partial p}{\partial x} dx \, dy \, dz + \frac{\partial \tau}{\partial y} dx \, dy \, dz = 0$$

or

$$\frac{\partial p}{\partial x} = \frac{\partial \tau}{\partial y} \quad (2)$$

For a Newtonian fluid in a laminar flow, the shear stress is directly related to the velocity gradient with the proportionality constant being the absolute viscosity  $\mu$  (see Figure 5):

$$\tau = \mu \frac{dv}{dy} \quad (3)$$

$$\frac{\partial \tau}{\partial y} = \mu \frac{\partial^2 v}{\partial y^2}$$

where  $v$  is the fluid velocity. Substituting Equation 3 into Equation 2, we obtain

$$\frac{\partial p}{\partial x} = \mu \frac{\partial^2 v}{\partial y^2} \quad (4)$$

Integrating with respect to  $y$  twice produces the following equation:

$$v = \frac{1}{\mu} \frac{\partial p}{\partial x} \frac{y^2}{2} + C_1 y + C_2 \quad (5)$$

where  $C_1$  and  $C_2$  are constants of integration. The boundary conditions are

$$v = 0, y = 0 \text{ and} \quad (6)$$

$$v = u, y = h$$

Substituting the boundary conditions of Equation 6 into Equation 5 results in the following expression for  $v$ :

$$v = \frac{1}{2\mu} \frac{\partial p}{\partial x} (y^2 - h^2 y) + \frac{uy}{2} \quad (7)$$

The velocity in the  $z$  direction would be similar, except that the surface velocity term would be omitted because no surface velocity exists in the  $z$  direction. In addition, the pressure gradient would be with respect to  $z$ .

Now let us consider the flow across the film due to this velocity. Note that Equation 7 is the velocity computed in the  $x$  direction, which is in the direction of rotation of the journal:

$$q_x = \int_0^h v_x dy = \int_0^h \left[ \frac{1}{2\mu} \frac{\partial p}{\partial x} (y^2 - h^2 y) + \frac{uy}{2} \right] dy \quad (8)$$

After integrating,

$$q_x = -\frac{1}{12\mu} \frac{\partial p}{\partial x} h^3 + \frac{1}{2} uh \quad (9)$$

Note that  $q_x$  is the flow per unit width across the film. The flow in the axial direction is

$$q_z = -\frac{1}{12\mu} \frac{\partial p}{\partial z} h^3 \quad (10)$$

Now let us consider a flow balance through an elemental volume across the film (see Figure 6). The net outflow through the volume equals the net reduction in volume per unit time:

$$\left( q_x + \frac{\partial q_x}{\partial x} dx \right) dz - q_x dz + \left( q_z + \frac{\partial q_z}{\partial z} dz \right) dx - q_z dx = -\frac{\partial h}{\partial t} dx dz \quad (11)$$

Thus, this gives us

$$\frac{\partial q_x}{\partial x} + \frac{\partial q_z}{\partial z} = -\frac{\partial h}{\partial t} \quad (12)$$

Substituting Equations 9 and 10 into Equation 12, we obtain

$$-\frac{\partial}{\partial x} \left( \frac{1}{12\mu} h^3 \frac{\partial p}{\partial x} \right) - \frac{\partial}{\partial z} \left( \frac{1}{12\mu} h^3 \frac{\partial p}{\partial z} \right) = -\frac{\partial h}{\partial t} - \frac{u}{2} \frac{\partial h}{\partial x} \quad (13)$$

and the final equation becomes

$$\frac{\partial}{\partial x} \left( \frac{h^3}{\mu} \frac{\partial p}{\partial x} \right) + \frac{\partial}{\partial z} \left( \frac{h^3}{\mu} \frac{\partial p}{\partial z} \right) = 6\mu \frac{\partial h}{\partial x} + 12 \frac{\partial h}{\partial t} \quad (14)$$

Equation 14 is the general form of Reynolds' equation used for laminar, two-dimensional lubrication problems.

Reynolds' equation is a flow balance equation. The left-hand side represents pressure-induced flows in the  $x$  and  $z$  directions through the differential element. The first term on the right-hand side represents the shear flow of the fluid induced by the surface velocity of the journal  $u$ . Note that this term contains the derivative of clearance with respect to distance. If this term is zero, then there is zero pressure produced by hydrodynamic action,

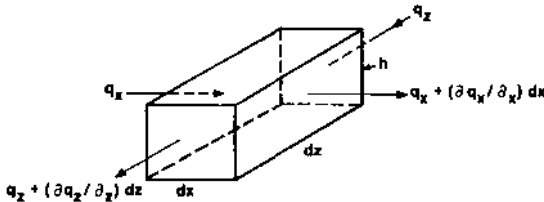


FIGURE 6 Flow balance across control volume.

and the term  $\partial h/\partial x$  is the mathematical representation of the tapered wedge. The second term on the right-hand side refers to a time rate of change of the film thickness, which can be translated to a normal velocity of the center of the journal. It produces pressure by a fluid velocity normal to the bearing surfaces that attempts to squeeze fluid out of a restricted clearance space. This phenomenon is called the squeeze film effect in bearing terminology. Since it is proportional to the velocity of the center of the journal, it is the phenomenon that produces viscous damping in a bearing.

The solution to Reynolds' equation (refer to Equation 14) provides the pressure at all points in the bearing. The application of the digital computer has enabled a rapid solution of Reynolds' equation over a grid network representing the bearing area.<sup>2,3</sup>

Once the pressures have been obtained, a numerical integration is applied to determine the performance parameters (in other words, the load capacity):

$$w = \iint prd\theta dr \quad (15)$$

The flow across any circumferential line is

$$q_\theta = \oint \left( -\frac{1}{12\mu} \frac{\partial p}{r\partial\theta} h^3 + \frac{1}{2} uh \right) dz \quad (16)$$

The flow across any axial line is

$$q_z = \oint \left( -\frac{1}{12\mu} \frac{\partial p}{\partial z} h^3 \right) rd\theta \quad (17)$$

The viscous frictional moment is obtained by integrating the shear stress over the area and can be shown to be

$$M_f = \iint \left[ \frac{1}{r} \frac{\partial p}{\partial\theta} \frac{h}{2} + \frac{\mu r\omega}{h} \right] r^2 d\theta dz \quad (18)$$

where  $\omega$  = journal surface speed, rad/s.

Typical computer program output includes the following:

- Pressure distribution throughout the grid network
- Load capacity
- Side leakage and carryover flows
- Viscous power losses
- Righting moments due to misalignments
- Attitude angles
- Cross-coupled spring and damping coefficients due to displacements and velocity perturbations of the journal center
- Clearance distribution

**Turbulence** Equation 14 is for laminar conditions. For very high speed bearings, operations beyond the turbulent regime may occur and Reynolds' equation must be modified. The turbulent theory has been developed, and the literature on this topic can enable performance predictions for turbulent bearings.<sup>5,6</sup>

The onset of turbulence is determined by examining the bearing's Reynolds number, which is the ratio of inertia to viscous forces and is defined as

$$Re = \frac{\rho u h}{\mu} \quad (19)$$

where  $Re$  = Reynolds number

$\rho$  = fluid density, lb · s<sup>2</sup>/in<sup>4</sup> (kg/m<sup>3</sup>)

$u$  = surface velocity, in/s (m/s)

$h$  = local film thickness, in (m)

$\mu$  = viscosity, lb · s/in<sup>2</sup> (Pa · s)

A reasonable approximation is to use the concentric clearance  $c$  for  $h$ . In terms of  $N$  rpm and journal diameter  $D$ , the Reynolds number is

$$Re = \rho \frac{\pi D N}{60} \frac{c}{\mu} \quad (20)$$

The criterion for turbulence in journal bearings is that  $Re \geq 1000$ .

EXAMPLE As an example, consider the following:

Journal diameter  $D = 5$  in (127 mm)

Bearing length  $L = 5$  in (127 mm)

Radial clearance  $c = 0.0025$  in (0.064 mm)

Operating speed  $N = 5000$  rpm

Lubricant viscosity  $\mu = 2 \times 10^{-6}$  lb · s/in<sup>2</sup> ( $14 \times 10^{-3}$  Pa · s)

Lubricant density  $\rho = 7.95 \times 10^{-5}$  lb · s<sup>2</sup>/in<sup>4</sup> ( $8.66 \times 10^{-11}$  kg · s<sup>2</sup>/mm<sup>4</sup>)

$$\begin{aligned} Re &= \rho \frac{\pi D N}{60} \frac{c}{\mu} \\ &= 7.95 \times 10^{-5} \times \frac{\pi \times 5 \times 5000}{60} \times \frac{0.0025}{2 \times 10^{-6}} = 130 \end{aligned}$$

Thus, the bearing is operating in the laminar regime. To become turbulent (assuming constant viscosity), the operating speed would have to increase to approximately 38,500 rpm.

The example cited is for a relatively high-speed, oil-lubricated bearing for pump applications. In general, most pump bearings operate in the laminar regime. Exceptions might occur when water is used as the lubricant because it is much less viscous than oil.

**Evaluation of Frictional Losses** It is often desirable to obtain a quick estimate of viscous drag losses that the journal bearings produce. If we consider shear forces again, we return to the laminar flow equation:

$$F = \mu A \frac{\mu}{h} \quad (21)$$

where  $F$  = viscous shear force, lb (N)

$\mu$  = viscosity, lb · s/in<sup>2</sup> (Pa · s)

$A$  = surface area, in<sup>2</sup> (m<sup>2</sup>)

$u$  = journal velocity, in/s (m/s)

$h$  = film thickness, in (m)

To obtain friction, we multiply both sides of Equation 21 by the journal radius  $R$ . Then the viscous frictional moment is

$$M = \mu A R \frac{u}{h}$$

The frictional horsepower loss is

$$FHP = \frac{NM}{63,000}$$

where  $N$  = rotating speed, rpm

$M$  = moment, lb · in ( $N \cdot m$ )

Also

$A$  = surface area of bearing =  $\pi DL$ , in<sup>2</sup> (m<sup>2</sup>)

$u$  = surface speed =  $\frac{\pi DN}{60}$  in/s (m/s)

Substituting, we obtain

$$FHP = \frac{\mu L D^3 N^2}{766,000h} \quad (22)$$

In obtaining approximate losses for estimation purposes, the concentric clearance  $c$  is substituted for the local film thickness  $h$ .

If we consider the previous example where  $D = 5$  in (127 mm),  $L = 5$  in (127 mm),  $c = 0.0025$  in (0.064 mm),  $N = 5000$  rpm, and  $\mu = 2 \times 10^{-6}$  lb · s/in<sup>2</sup> ( $14 \times 10^{-3}$  Pa · s), the horsepower loss is

$$FHP = \frac{(2 \times 10^{-6})(5)(5)^3(5000)^2}{(766,000)(0.0025)} = 16.32 \text{ hp}$$

Note that for thrust bearings, the frictional horsepower loss is

$$FHP = \frac{\mu N^2}{h} \frac{OD^4 - ID^4}{6.127 \times 10^6} \quad (23)$$

where  $OD$  = outside diameter

$ID$  = inside diameter

A general rule of thumb is that the frictional horsepower in a thrust bearing is approximately twice that in a journal bearing.

## BEARING TYPES

---

**Cylindrical Bearing** The most common type of journal bearing is the plain cylindrical bushing shown schematically in Figure 1. It can be split and have lubricating feed grooves at the parting line. A ramification is to incorporate axial grooves to enable better cooling and to improve whirl stability (described in more detail below in the discussion of cylindrical bearings with axial grooves). The principle advantages of cylindrical bearings are (1) simple construction and (2) a high-load capacity relative to other bearing configurations.

This type of bearing also has several disadvantages:

- **Whirl Instability:** This is prone to subsynchronous whirling at high speeds and also at low loads. Whirling is an orbiting of the journal (shaft) center in the bearing, a motion that is superimposed upon the normal journal rotation. The orbital frequency is approximately half the rotating speed of the shaft. The expression *half-frequency whirl* is commonly used. The reason for the occurrence of this whirl and more details concerning bearing dynamics are presented in the section on bearing dynamics.
- **Viscous Heat Generation:** Because of the generally large and uninterrupted surface area of this bearing, it generates more viscous power loss than some other types.

- **Contamination:** The cylindrical bearing is more susceptible to contamination problems than other types because contaminants that are dragged in at the leading edge of the bearing cannot easily dislodge because of the absence of grooves or other escape paths.

The advantages of simplicity and load capacity make the plain journal a leading candidate for most applications, but performance should be carefully investigated for whirl instability and potential thermal problems. Cylindrical bearings are generally used for medium-speed (500 in/s [200 mm/sec] surface speed) and medium- to heavy-load applications (250 to 400 lb/in<sup>2</sup> [17 to 28 bar] on a projected area).

**Cylindrical Bearing with Axial Grooves** A typical configuration of this type of bearing is a plain cylindrical bearing with four equally spaced longitudinal grooves extending most of the way through the bearing. Usually, a slight land area exists at either end of the groove to force the inlet flow to each groove into the bearing clearance region (see Figure 7), rather than out the groove ends. This configuration is a little less simple than the plain cylindrical bearing, and because the grooves consume some land area, this configuration has less load capacity than the plain bushing. Since oil is fed into each of the axial grooves, this bearing requires more inlet flow but also will run cooler than the plain bushing. The grooves act as convenient outlets for any contaminants in the lubricant, and thus the grooved bearing can tolerate more contamination than the plain cylindrical bearing.

In general, this bearing can be considered as an alternate to a plain bearing if the former can correct a whirl or overheating problem.

**Elliptical and Lobe Bearings** Elliptical and lobe bearings have noncircular geometries. Figure 8 shows two types of three-lobe bearings with the clearance distribution exaggerated so that the lobe geometry is easily discernible. An elliptical bearing is simply a two-lobe bearing with the major axis along the horizontal axis.

The lobe bearing shown in Figure 8a is a symmetric lobe bearing where the minimum concentric clearance occurs in the center of each lobed region. Thus, at the leading edge region, a converging clearance produces positive pressure, but downstream from the minimum film thickness, a divergent film thickness distribution can be found with resulting negative, or cavitation, pressures.

The canted lobe in Figure 8b, on the other hand, generally develop positive pressure throughout the lobe because the bearing is constructed with a completely converging film thickness in each lobed region. This design has excellent whirl resistance (superior to that of the symmetric lobe bearing) and a reasonably good load capability. A 2:1 ratio between leading and trailing edge concentric clearance is generally a reasonable compromise with respect to performance.

Elliptical and lobe bearings are often used because they provide better resistance to whirls than cylindrical configurations. They do so because they have multiple load-producing pads that assist in preventing large-attitude angles and cross-coupling (see the section on bearing dynamics). Elliptical and lobe bearings are generally used for high-speed, low-load applications where whirls might be a problem.

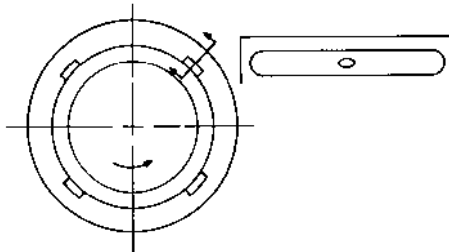


FIGURE 7 Cylindrical bearing with axial grooving.

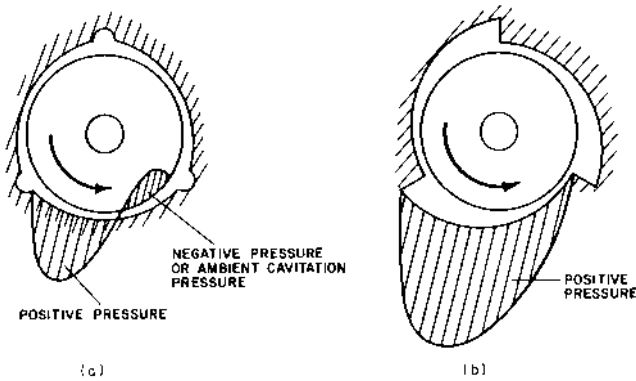


FIGURE 8 (a) symmetric lobe bearing and (b) canted lobe bearing.

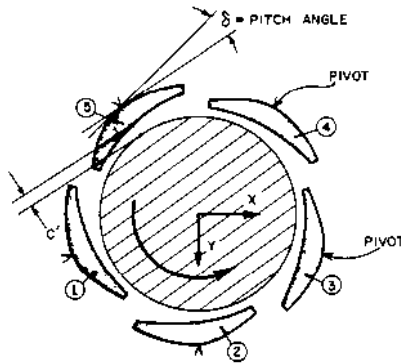


FIGURE 9 Five-pad tilting pad bearing.

Elliptical, or two-lobe, bearings generally have poor horizontal stiffness because of the large clearances along the major diameter of the ellipse. The split elliptical configuration, however, is easier to manufacture than the other types because it is two cylindrical bearing halves with material removed along the parting line. Lobe bearings are usually clearance- and tolerance-sensitive. The other types of lobe bearings are complicated to manufacture.

**Tilting-Pad Bearings** Tilting-pad bearings are used extensively, especially in high-speed applications, because of their whirl-free characteristics. They are the most whirl-free of all bearing configurations.

An important geometric variable for tilting-pad bearings is the preload ratio, defined as shown in Figure 9.

The preload ratio equals

$$\text{Preload ratio} = PR = \frac{c - c'}{c} = 1 - \frac{c'}{c} \quad (24)$$

where  $c$  = machined clearance

$c'$  = concentric pivot film thickness

The variable  $c'$  is an installed clearance and is dependent upon the radial position of the pivot. Figure 10 displays two pads. Pad 1 has been installed such that the preload ratio



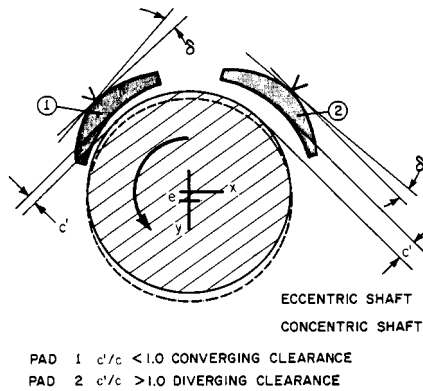


FIGURE 10 Tilting-pad bearing preload.

is less than one. For pad 2, the preload ratio is one. The solid line represents the position of the journal in the concentric position. The dashed portion of the journal represents its position when a load is applied to the bottom pads (not shown). Pad 1 is operating with a good converging wedge, even though the journal is moving away from it. Pad 2, on the other hand, is operating with a completely diverging film, which means that it is totally unloaded. Thus, bearings with installed pad preload ratios of one or greater will operate with unloaded pads, which reduces overall stiffness of the bearing and results in a deterioration of stability because the unloaded pads do not aid in resisting cross-coupling influences. In the unloaded position, they are also subject to flutter instability and to a phenomenon known as *leading edge lockup*, where the leading edge is forced against the shaft and is maintained in that position by the frictional interaction of the shaft and the pad. This is especially prevalent in bearings that operate with low-viscosity lubricants, such as gas or water bearings. Thus, it is important to design bearings with preload, although for manufacturing reasons it is common practice to produce bearings without preload.

Tilting-pad bearings have some other characteristics that are both positive and negative:

- They are not as clearance-sensitive as most other bearings.
- Because the pads can move, they can operate safely at a lower minimum film thickness than other bearings.
- They do not provide as much squeeze film damping as rigid configurations.
- Generally, they are more expensive than other bearings.
- For high-speed applications, their pivot contacts can be subjected to fretting corrosion.

**Hybrid Bearings** A hybrid bearing, schematically shown in Figure 11, derives a load capacity from two sources: (1) the normal hydrodynamic pressure generation and (2) an external high-pressure supply that introduces oil into recesses machined into the bearing surface via restrictors (orifices or capillaries upstream of the recesses). External pressure significantly enhances load capacity. Also, these bearings have excellent low- or zero-speed load capabilities. They are sometimes used as startup devices to lift off the rotor. When self-sustaining hydrodynamic speeds are attained, the external pressure is shut off. The characteristics of externally pressurized, or hybrid, bearings include the following:

- High load and stiffness capabilities
- An external flow that assists in cooling

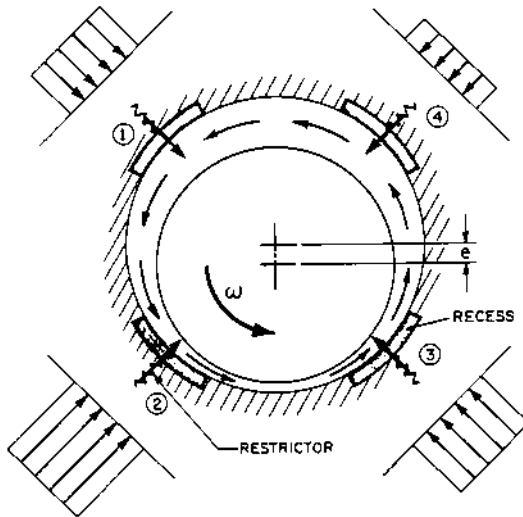


FIGURE 11 Cross-coupling influences in hybrid bearings.

- Their clearances and tolerances are generally more liberal than in hydrodynamic bearings
- They require external fluid-supply systems
- They are applied when there is not a sufficient generating speed or when a high-load capacity and stiffness are required
- They are sometimes applied to prevent a whirl, but rotational speeds can unbalance recess pressures, introduce cross coupling, and promote a whirl.

### STEADY STATE PERFORMANCE

Computer-generated performances have been obtained for most of the bearing types previously discussed. Information has been plotted in a nondimensional format so that no restrictions exist on operating conditions, lubricant properties, and so on. Use of the charts will be subsequently demonstrated by numerical example.

**Viscosity** One of the key parameters in determining the performance of a bearing is the lubricant viscosity. Viscosity characteristics of commonly used Society of Automotive Engineers (SAE) grades of oil are shown in Figure 12. The units of viscosity are *microreyns*, where the reyn has the units of  $\text{lb} \cdot \text{s}/\text{in}^2$  and comes from the ratio of shear stress to the velocity gradient across the film, as indicated by Equation 21. Other units of viscosity are *centipoises*, *Saybolt seconds universal* (SSU), and *centistokes*. The conversion factors are as follows:

$$\mu(\text{reyns}) = Z \times 1.45 \times 10^{-7} \quad (25)$$

$$\nu(\text{centistokes}) = 0.22 (\text{SSU}) - \frac{180}{\text{SSU}} \quad (26)$$

$$Z(\text{centipoises}) = \nu(\text{centistokes}) \times \text{SG} (\text{sp. gr.}) \quad (27)$$

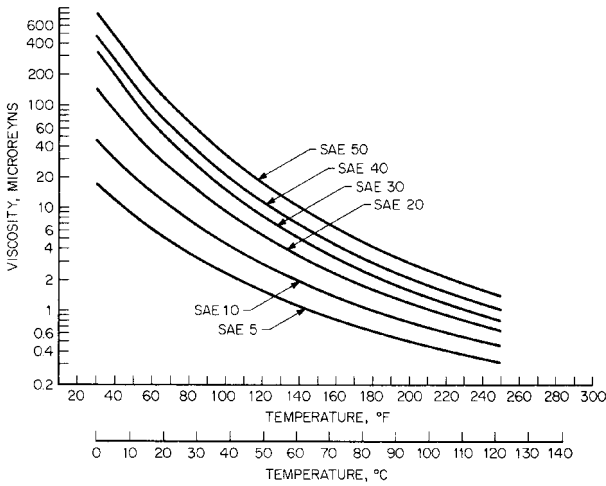


FIGURE 12 Viscosity characteristics for SAE oil grades.

**Performance Curves** Performance plots have been generated for the following types of bearings:

- *Two-groove cylindrical bearings*
- *Symmetric three-lobe bearings:* Each lobe is offset such that in the concentric position the minimum film thickness in the center of each lobed region is half the machined clearance  $c$  (see definition following). The pads are each  $110^\circ$  in the angular extent.
- *Canted three-lobe bearing:* The lobing is canted such that in the concentric position the leading edge clearance was twice the trailing edge and the trailing edge film thickness (minimum) in the concentric position was  $0.5c$  where  $c$  equals the machined clearance. The pads are each  $110^\circ$  in the angular extent.
- *Tilting-pad bearing:* The tilting-pad bearing that information is obtained for is a five-pad bearing with a  $60^\circ$  pad and a preload ratio of 30 percent.

Two length/diameter ratios are examined for each type of bearing:  $L/D = 0.5$  and  $1.0$ . The definition of the nondimensional parameters is as follows:

$$W = \text{nondimensional load parameter} = \frac{wc^2}{6\mu\omega RL^3} \quad (28)$$

$$P = \text{nondimensional viscous power loss parameter} = \frac{1100cp}{\mu(\omega RL)^2} \quad (29)$$

$$Q = \text{nondimensional flow parameter} = \frac{2q}{0.26\omega RLc} \quad (30)$$

$$HM = \text{nondimensional minimum film thickness} = \frac{h_M}{c} \quad (31)$$

where  $w$  = bearing load capacity, lb (N) and

$c$  = reference clearance (machined clearance = radius of bearing – radius of shaft), in (mm)

$\mu$  = absolute viscosity, reyns (lb · s/in<sup>2</sup>) (cP)

$\omega$  = shaft or journal rotational speed rad/s

$R$  = shaft radius, in (mm)

$L$  = bearing length, in (mm)

$p$  = viscous power loss, hp (kW)

$q$  = flow, gpm (m<sup>3</sup>/h)

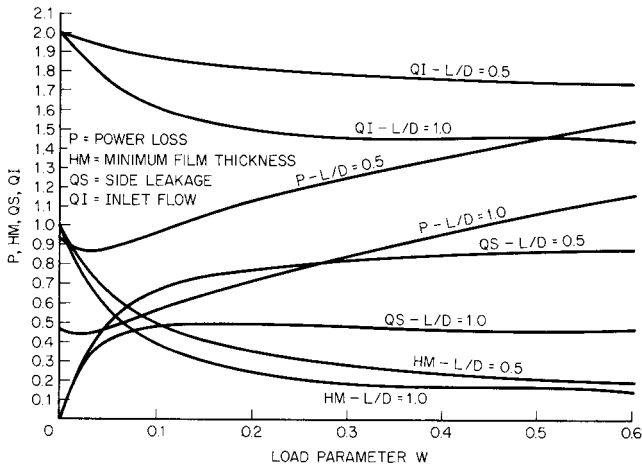


FIGURE 13 Performance characteristics for two-groove cylindrical bearings.

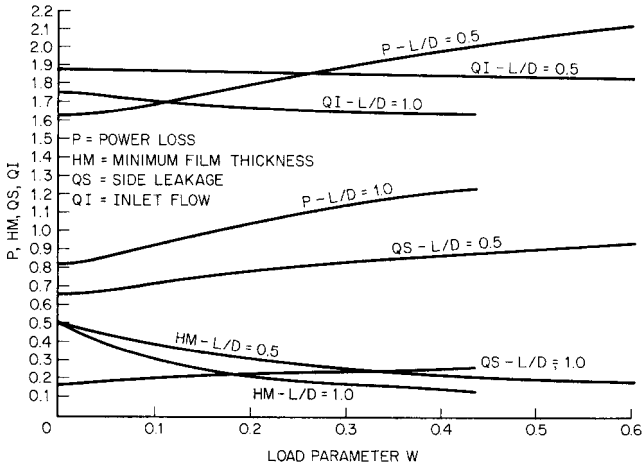


FIGURE 14 Performance characteristics for three-lobe bearings.

$q_i$  = inlet flow to the leading edge of bearing (for multipad bearings, equals the sum of inlet flow to each pad), gpm ( $\text{m}^3/\text{h}$ )

$q_s$  = side leakage flow or flow out of the bearing ends (for multipad bearings, equals the sum of side leakage flow of each pad), gpm ( $\text{m}^3/\text{h}$ )

$h_M$  = minimum film thickness in bearing, in (mm)

Performance curves are shown in Figures 13 through 17.

At times, the nondimensional data can be confusing and lead to erroneous judgments. For example, the nondimensional power loss  $P$  is greater for an  $L/D$  equal to 0.5 than for an  $L/D$  equal to 1.0. However, when the dimensional value of the power loss is being computed, the nondimensional value is multiplied by  $L^2$ . Therefore, the power loss for the  $L/D$

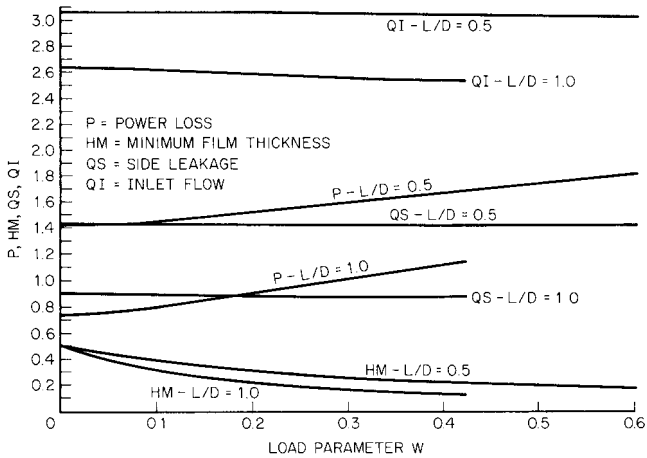


FIGURE 15 Performance characteristics for canted three-lobe bearings.

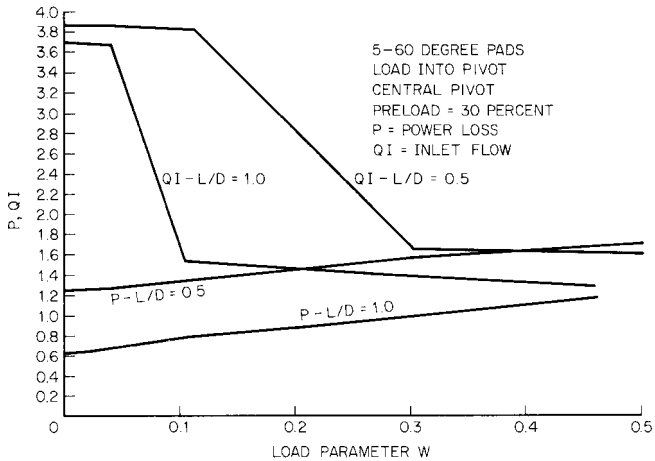


FIGURE 16 Performance characteristics for tilting-pad bearings.

equal to 1.0 will be, as expected, greater than for the  $L/D$  equal to 0.5. If the reader uses the data as presented, the dimensional information will prove consistent.

To make comparisons among the bearings, using the nondimensional data is not strictly proper because there may be slight inconsistencies in preloads, the bearings will not be operating at the same average viscosity, and so on. Subsequently, dimensional data derived from the performance curves will be compared, but comparisons of the nondimensional information will provide an indication of performance parameters among the bearings. Comparisons have been made at equal values of the load parameter  $W$  and the results are shown in Table 1.

Comparisons of the different bearing types should be made only at the same  $L/D$  ratio because of the anomalies (discussed above) of nondimensional parameters that occur at

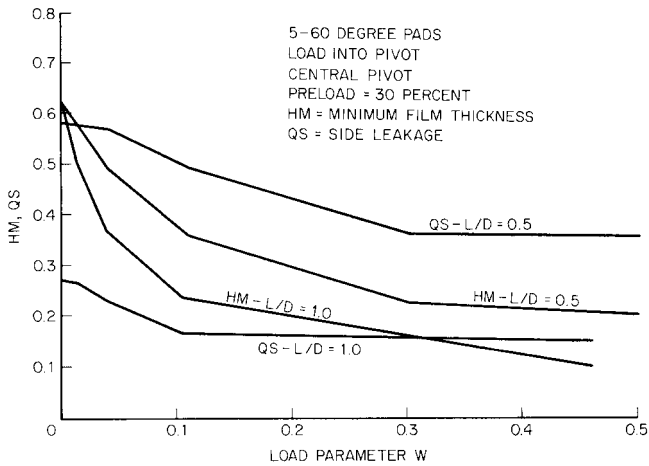


FIGURE 17 Performance characteristics for tilting-pad bearings.

TABLE 1 Comparative Results of Bearing Types at  $W = 0.2$

Bearing type	$L/D = 0.5$				$L/D = 1$			
	$P$	$HM$	$QS$	$QI$	$P$	$HM$	$QS$	$QI$
Two-groove cylindrical	1.13	0.36	0.78	1.81	0.72	0.25	0.50	1.50
Three-lobe	1.80	0.32	0.79	1.85	1.05	0.22	0.22	1.65
Canted three-lobe	1.52	0.31	1.42	3.30	0.91	0.22	0.90	2.58
Tilting-pad	1.50	0.30	0.44	2.82	0.90	0.20	0.16	1.50

$QI$  = nondimensional inlet flow =  $2qi/0.26 wRLc$

$QS$  = nondimensional side leakage flow =  $2q_s/0.26 wRLc$

different  $L/D$  ratios. If we assume that all the reference variables that go into the nondimensional parameters are identical, we can establish the following conclusions:

- The two-groove cylindrical bearing has the highest film thickness and thus the highest load capacity.
- The symmetric three-lobe bearing has the highest power loss.
- The canted three-lobe bearing has the greatest flow requirements.

Note that these comparisons were made on the basis of steady-state performances only. The major reason for applying lobe and tilting-pad bearings is to avoid dynamic instabilities.

**Heat Balance** Performance is based upon the assumption of a uniform viscosity in the fluid film. Since the viscosity is a strong function of temperature and since the temperature rise of the lubricant due to viscous heat generation is not known a priori, an iterative procedure is required to determine the average viscosity in the film. To determine an average viscosity, there must be a simplified heat balance in the film. The assumption is made that all the viscous heat generated in the film is absorbed by the lubricant as it flows through the film and produces a temperature rise.

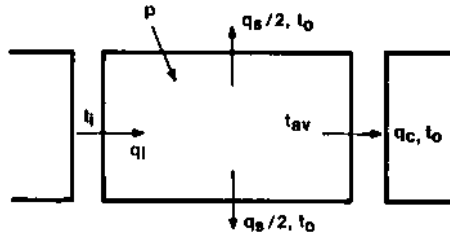


FIGURE 18 Heat balance in a fluid film.

Figure 18 shows a developed view of the bearing surface and the parameters involved with conducting the heat balance. The lubricant enters a pad or bearing at the leading edge with an inlet flow  $q_i$  and an inlet temperature  $t_i$ . As the lubricant enters the bearing surface and flows through it, the lubricant is exposed to a viscous shear, which adds heat to the fluid. In Figure 18, the viscous shear is indicated as a power input  $p$ . Some of the fluid flows out of the sides of the bearing, represented by  $q_s/2$ , and some of the fluid,  $q_c$ , is carried either over to the grooving of the next pad or back to the inlet groove for a single pad bearing.

Although the fluid temperature, and thus the viscosity, changes along the length of the pad, it is assumed that the temperature in the film increases to some value  $t_o$  for both the side leakage and carry-over fluids. Then the heat balance is conducted as follows:

Heat added to a fluid by a viscous shear equals heat absorbed by the fluid.

$$\begin{aligned} \text{Heat added to fluid by viscous shear} &= \text{heat absorbed by fluid} \\ pJ &= q_s \rho C_p (t_o - t_i) = q_c \rho C_p (t_o - t_i) = (q_s + q_c) \rho C_p (t_o - t_i) \end{aligned} \quad (32)$$

Since by continuity of flow,

$$q_i = q_s + q_c \quad (33)$$

$$pJ = q_i \rho C_p \Delta t \quad (34)$$

$$\Delta t = \frac{pJ}{q_i \rho C_p} \quad (35)$$

where  $p$  = viscous heat generation, hp

$J$  = heat equivalent constant = 0.7069 Btu/hp · s (J/kg · s)

$\rho$  = specific weight of flow, lb/in<sup>3</sup> (kg/m<sup>3</sup>)

$C_p$  = specific heat of fluid, Btu/lb · °F (J/kg · °C)

$q_i$  = bearing inlet flow, in<sup>3</sup>/s (mm<sup>3</sup>/s)

$\Delta t$  = temperature rise, °F (°C)

If  $q_i$  is in gallons per minute [(1 in<sup>3</sup>/s = 0.26 gpm) = 16.39 cm<sup>3</sup>/s],

$$\Delta t = \frac{0.7069(0.26)p}{q_i \rho C_p} = \frac{0.1838p}{q_i \rho C_p} \quad (36)$$

Before proceeding to a sample problem, a word about the flows  $q_i$  and  $q_s$ , and the general heat balance philosophy. The flow required by the bearing to prevent starvation is  $q_i$ . The minimum make-up flow, or the flow that is lost from the ends of the bearing, is the side leakage  $q_s$ . Theoretically then, the only flow that need be supplied to the bearing is  $q_s$ . However, if this were true, then the heat balance formulation would require another balance between the carry-over flow  $q_c$  at some temperature  $t_o$  and the make-up flow  $q_s$  coming into the pad at temperature  $t_i$ . It would be found that, if we supplied only  $q_s$  to the bearing, excessive temperatures would result. In most instances, the amount of flow supplied to a bearing exceeds both the inlet flow and the side leakage flow by a significant

margin. Designers often determine the flow to be supplied to a bearing system by a bulk temperature rise of the total flow entering the inlet pipe and exiting the exhaust pipe. Thus, the entire bearing is treated as a black box, and the total flow  $q_T$  to the bearing system for a given bulk temperature rise  $\Delta t_i$  is

$$q_T = \frac{pJ}{\rho C_p \Delta t_i} \quad (37)$$

Normally,  $\Delta t_i$  is selected between 20 and 40°F. Since  $q_T$  will exceed  $q_i$ , not all the flow will enter the film. Some will surround the bearing or flow through the feed groove and act as a cooling medium for heat transfer through the bearing walls or for cooling the fluid that does enter the bearing surface  $q_i$ .

**EXAMPLE** This example demonstrates the use of the design curves and how to perform a simplified heat balance in a bearing analysis.

In this example, we know these values:

Bearing type: two-groove cylindrical

Bearing length  $L = 3$  in (76 mm)

Bearing diameter  $D = 6$  in (152 mm)

$L/D = 0.5$

$N = 1800$  rpm;  $\omega = 1800 \times \pi/30 = 188.5$  rad/s

Bearing load  $\omega = 6000$  lb (2721 kg)

Inlet temperature  $t_i = 120^\circ\text{F}$  ( $49^\circ\text{C}$ )

Lubricant = SAE 20

Bearing radial clearance  $c = 0.003$  in (0.076 mm)

**NOTE:** A general rule of thumb is that  $c/R = 0.001$ .

Assume an average lubricant temperature of  $130^\circ\text{F} - \mu$  (SAE 20 at  $130^\circ\text{F}$ ) =  $4.5 \times 10^{-6}$  reyn (lb · s/in<sup>2</sup>) ( $31 \times 10^{-3}$  Pa · s)

$$\rho = 0.0307 \text{ lb/in}^3 (849.7 \text{ kg/m}^3) \text{ (average value for most oils)}$$

$$C_p = 0.5 \text{ Btu/lb} \cdot \text{F}^\circ (2093 \text{ J/kg} \cdot \text{C}^\circ) \text{ (average value for most oils)}$$

Compute the following:

$$W = \frac{wc^2}{6\mu\omega RL^3} = \frac{(6000)(0.003^2)}{(6)(4.5 \times 10^{-6})(188.5)(3)(3^3)} = 0.1309$$

From Figure 13 and Equation 29,

$$P = 1.0 = \frac{1100cp}{\mu(\omega RL)^2}$$

$$P = \frac{(1)(4.5 \times 10^{-6})(188.5 \times 3 \times 3)^2}{(1100)(0.003)} = 3.92 \text{ hp (2.95 kW)}$$

From Figure 13 and Equation 30,

$$Q_i = 1.85 = \frac{2q_i}{0.26\omega RLC}$$

$$q_i = \frac{(1.85)(0.26)(188.5)(3)(3)(0.003)}{2} = 1.224 \text{ gpm (4.63 l/min)}$$

From Equation 36,



$$\Delta t = \frac{0.1838p}{q_i \rho C_p} = \frac{(0.1838)(3.92)}{(1.224)(0.0307)(0.5)} = 38.35 \text{ F}^\circ (21.3 \text{ C}^\circ)$$

$$t_{av} = \frac{t_i + (t_i + \Delta t)}{2} = \frac{2t_i + \Delta t}{2} = \frac{(2)(120) + 38.85}{2} = 139.2^\circ\text{F} (59.6^\circ\text{C})$$

The assumed  $t_{av}$  of  $130^\circ\text{F}$  was apparently not high enough and therefore we must repeat the calculations with a higher value of assumed  $t_{av}$ . Assume  $t_{av} = 138^\circ\text{F}$ ,  $\mu = 3.8 \times 10^{-6} \text{ lb} \cdot \text{s/in}^2 (26.2 \times 10^{-3} \text{ Pa} \cdot \text{s})$  and repeat the calculations:

$$W = \frac{5.8945 \times 10^{-7}}{\mu} = 0.1552$$

$$P = 1.08 = (1.1466 \times 10^{-6}) \left( \frac{P}{\mu} \right)$$

$$p = \frac{(1.08)(3.8 \times 10^{-6})}{1.1466 \times 10^{-6}} = 3.579 \text{ hp} (2.67 \text{ kW})$$

$$QI = 1.83 = \frac{q_i}{0.6616}$$

$$q_i = 1.211 \text{ gpm} (4.58 \text{ l/min})$$

$$\Delta t = 11.974 \frac{p}{q_i} = \frac{(11.974)(3.579)}{1.211} = 35.38 \text{ F}^\circ (19.65 \text{ C}^\circ)$$

$$t_{av} = \frac{(2)(120) + 35.38}{2} = 137.7^\circ\text{F} (58.7^\circ\text{C})$$

For all practical purposes, these equal the assumed value of  $t_{av} = 138^\circ\text{F} (58.9^\circ\text{C})$ .

In conducting the iterative procedure for determining the average fluid temperature, it is sometimes helpful to plot points on a viscosity chart. Referring to Figure 19, suppose

### 2.2.5 CENTRIFUGAL PUMP OIL FILM JOURNAL BEARINGS

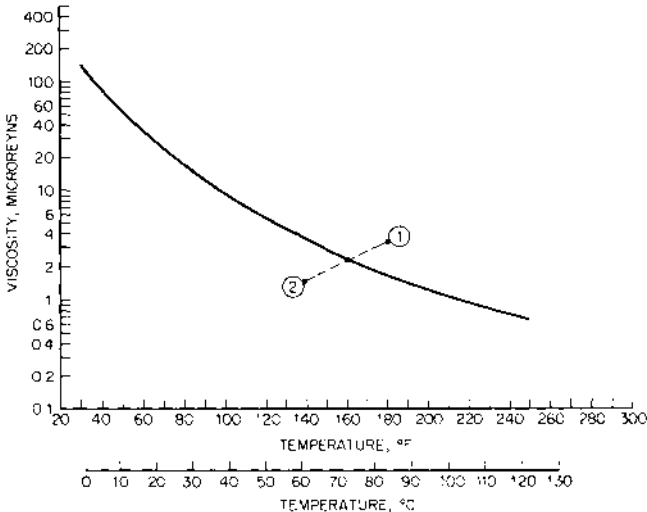


FIGURE 19 Graphical determination of average viscosity for SAE 20 oil.

point 1 is the resultant average viscosity and temperature of the initial guess and point 2 represents the result of the second guess. Then, by drawing a straight line between points 1 and 2 and establishing where it intersects the lubricant viscosity curve, we can determine the convergence to the proper result of average viscosity and temperature.

Now that we have convergence, we can determine the remaining variables, which are the minimum film thickness  $H_M$  and side leakage  $Q_s$  from Figure 13:

$$HM = 0.41 = \frac{h_M}{c}$$

$$h_M = (0.41)(0.003) = 0.00123 \text{ in (0.031 mm)}$$

$$QS = 0.74 = \frac{2q_s}{0.26\omega RLC} = \frac{q_s}{0.6616}$$

$$q_s = (0.6616)(0.74) = 0.490 \text{ gpm (1.85 l/min)}$$

A summary of the total bearing performance is as follows:

Load  $\omega = 6000 \text{ lb (2721 kg)}$

Minimum film thickness  $h_M = 0.00123 \text{ in (0.031 mm)}$

Viscous power loss  $\rho = 3.579 \text{ (2.669 kW)}$

Inlet flow  $q_i = 1.211 \text{ gpm (4.58 l/min)}$

Side leakage  $q_s = 0.490 \text{ gpm (1.85 l/min)}$

Fluid temperature rise  $\Delta t = 35.38^\circ\text{F (19.65}^\circ\text{C)}$

We can repeat the same calculation for the other types of bearings, using Figures 14 through 17. The results are shown in Table 2.

The two-groove cylindrical bearing operates with the highest film thickness. The symmetric three-lobe has the lowest film thickness and highest temperature rise. It appears that, on the basis of steady-state performance, manufacture, and cost, the two-groove cylindrical bearing is the best choice.

## BEARING DYNAMICS<sup>7</sup>

Fluid film bearings can significantly influence the dynamics of rotating shafts. They are a primary source of damping and thus can inhibit vibrations. Alternatively, they provide a

**TABLE 2** Comparative Bearing Performance

Bearing type	$\Delta t$ , °F (°C)	$t_{av}$ , °F (°C)	$p$ , hp	$q_i$ , gpm (cm <sup>3</sup> /s)	$q_s$ , gpm (cm <sup>3</sup> /s)	$h_M$ , mils (mm)
Two-groove cylindrical	35 (19.44)	138 (58.9)	3.58	1.21 (76.7)	0.490 (31.05)	1.23 (0.0312)
Symmetric three-lobe	49 (27.22)	144 (62.2)	4.97	1.22 (77.3)	0.516 (32.7)	0.96 (0.0244)
Canted three-lobe	31 (17.22)	135 (57.2)	5.20	2.01 (127.4)	0.940 (59.6)	1.05 (0.0267)
Tilting-pad	26 (14.44)	134 (56.7)	4.88	2.26 (143.2)	0.311 (19.71)	1.02 (0.0259)

The following values were used:  $\omega = 6000 \text{ lb (2721 kg)}$ , SAE 20 oil,  $L = 3 \text{ in (76 mm)}$ ,  $D = 3 \text{ in (76 mm)}$ ,  $N = 1800 \text{ rpm}$ ,  $t_i = 120^\circ\text{F (48.9}^\circ\text{C)}$ ,  $c = 0.008 \text{ in (0.076 mm)}$ .

mechanism for self-excited rotor whirl. Whirl is manifest as an orbiting of the journal at a subsynchronous frequency, usually close to one-half the rotating speed. Whirl is usually destructive and must be avoided.

It is the purpose of this section to provide some insight into bearing dynamics, present some background on analytical methods and representations, and discuss some particular bearings and factors that can influence dynamic characteristics. Dynamic performance data and sample problems are presented for several bearing types.

**The Concept of Cross Coupling** As mentioned in the opening paragraphs of this subsection, a journal bearing derives load capacity from viscous pumping of the lubricant through a small clearance region. To generate pressure, the resistance to pumping must increase in the direction of the fluid flow. This is accomplished by a movement of the journal such that the clearance distribution takes on the form of a tapered wedge in the direction of rotation, as shown in Figure 1.

The attitude angle  $\gamma$  in Figure 1 is the angle between the load direction and the line of centers. Thus, the displacement of the journal is not along a line that is coincident with the load vector, and a load in one direction causes not only displacements in that direction, but orthogonal displacements as well.

Similarly, a displacement of the journal in the bearing will cause a load opposing the displacement and a load orthogonal to it. Thus, strong cross-coupling influences are introduced by the mechanism by which a bearing operates. The concept of cross-coupling is significant in dynamic characteristics.

It is the cross-coupling characteristics of a journal bearing that can promote self-excited instabilities in the form of bearing whirl. Motion in one direction produces orthogonal forces that in turn cause orthogonal motion. The process continues, and an orbital motion of the journal results. This orbital motion is generally in the same direction as shaft rotation and subsynchronous in frequency. Half-frequency whirl is a self-excited phenomenon and does not require external forces to promote it.

**Cross-Coupled Spring and Damping Coefficients** For dynamic considerations, a convenient representation of bearing characteristics is a cross-coupled spring and damping coefficients. These are obtained as follows (refer to Figure 1):

1. The equilibrium position to support the given load is established by computer solution of Reynolds' equation.
2. A small displacement to the journal is applied in the  $y$  direction. A new solution of Reynolds' equation is obtained, and the resulting forces in the  $x$  and  $y$  directions are produced. The spring coefficients are as follows:

$$K_{xy} = \frac{\Delta F_x}{\Delta y} \quad (38)$$

$$K_{yy} = \frac{\Delta F_y}{\Delta y} \quad (39)$$

where  $K_{xy}$  = the stiffness in the  $x$  direction due to  $y$  displacement  
 $\Delta F_x$  = the difference in  $x$  forces between displaced and equilibrium positions  
 $\Delta y$  = the displacement from the equilibrium position in the  $y$  direction  
 $K_{yy}$  = the stiffness in the  $y$  direction due to  $y$  displacement  
 $\Delta F_y$  = the difference in  $y$  forces between displaced and equilibrium positions

3. The journal is returned to its equilibrium position and an  $x$  displacement is applied. Similar reasoning produces  $K_{xx}$  and  $K_{yx}$ .

The cross-coupled damping coefficients are produced in a similar manner, except, instead of displacements in the  $x$  and  $y$  direction, velocities in these directions are consecutively applied with the journal in the equilibrium position. The mechanism for increasing the load capacity is squeeze film in which the last term on the right-hand side of

Equation 14 is actuated. Thus, for most fixed bearing configurations, eight coefficients exist: four spring and four damping. The total force on the journal is

$$F_i = K_{ij}x_j + D_{ij}\dot{x}_j \quad (40)$$

where  $F_i$  = force in the  $i$ th direction.

Repeated subscripts imply the following summation:

$$K_{ij}x_j = K_{ix}x + K_{iy}y + \dots$$

It should be realized that the cross-coupled spring and damping coefficients represent a linearization of bearing characteristics. When they are used, the equilibrium position should be accurately determined, as the coefficients are valid for only a small displacement region encompassing the equilibrium position of the journal. This is true because the spring and damping coefficients remain constant for only a small region of the equilibrium position.

Consider the two-groove cylindrical bearing shown in Figure 1, with the geometric and operating conditions indicated in Table 3. The computer solution (also the performance curves in Figure 13) produces the following results:

Bearing load  $w = 20,780$  lb (9,424 kg)

Power loss = 15.51 hp (11.56 kW)

Minimum film thickness  $h_M = 0.00125$  in (0.032 mm)

Side leakage  $q_s = 0.941$  gpm (3.56 l/mm)

The spring and damping coefficients are

Spring coefficients, lb/in (kg/mm):

$$\begin{bmatrix} K_{xx} & K_{xy} \\ K_{yx} & K_{yy} \end{bmatrix} = \begin{bmatrix} -12.14 \times 10^6 & -4.64 \times 10^6 \\ 28.3 \times 10^6 & -20.41 \times 10^6 \end{bmatrix}$$

Damping coefficients, lb · s/in kg · s/in:

$$\begin{bmatrix} D_{xx} & D_{xy} \\ D_{yx} & D_{yy} \end{bmatrix} = \begin{bmatrix} -2.85 \times 10^4 & 2.66 \times 10^4 \\ -2.69 \times 10^4 & -1.11 \times 10^5 \end{bmatrix}$$

The negative signs imply a positive stiffness because the restoring load is opposite the applied load. Note that for this bearing configuration there is very strong cross-coupling, evidenced by the magnitude of the off-diagonal terms.

**Critical Mass** The cross-coupled spring and damping coefficients provide a convenient way of representing a bearing in a stability analysis. They reduce the fluid film bearing to a spring-mass system (see Figure 20), and consequently stability and dynamics problems are simplified considerably.

Consider a journal of mass  $M$  operating in a bearing. The journal can be considered to have two degrees of freedom,  $x$  and  $y$ . The governing equations are

**TABLE 3** Two-Groove Cylindrical Bearing Geometry and Operating Conditions

Journal diameter $D$	=	5 in (127 mm)
Bearing length $L$	=	5 in (127 mm)
Active pad angle $\theta_p$	=	160° (10° grooves on either side)
Radial clearance $c$	=	0.0025 in (0.064 mm)
Operating speed $N$	=	5000 rpm
Lubricant viscosity $\mu$	=	$2 \times 10^{-6}$ lb · s/in <sup>2</sup> ( $13.79 \times 10^{-3}$ Pa · s)
Eccentricity ratio $\varepsilon$	=	0.5
Load direction is vertical downward		

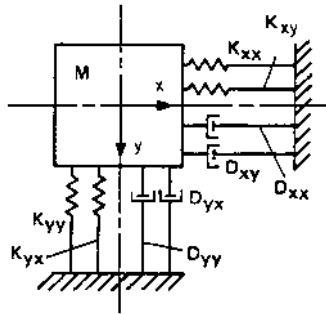
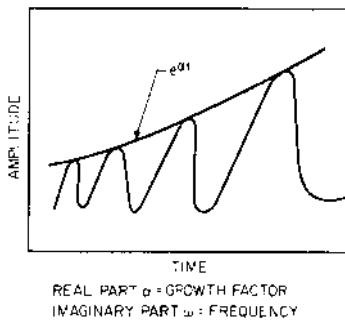


FIGURE 20 Point mass representation of a bearing supported on cross-coupled springs and dampers.



Interpretation of  $\chi = \chi_0 e^{\beta t}$

where

$$\beta = \alpha + i\omega$$

$$\chi = \chi_0 e^{\alpha t} e^{i\omega t} = \chi_0 e^{\alpha t} (\cos \omega t + i \sin \omega t)$$

FIGURE 21 Interpretation of the growth factor  $\alpha$  and orbital frequency  $\omega$ .

$$M\ddot{x} + D_{xx}\dot{x} + D_{xy}\dot{y} + K_{xx}x + K_{xy}y = 0 \quad (41)$$

$$M\ddot{y} + D_{yx}\dot{x} + D_{yy}\dot{y} + K_{yx}x + K_{yy}y = 0 \quad (42)$$

Assume a sinusoidal response to the form

$$x = x_0 e^{\beta t} \quad (43)$$

$$y = y_0 e^{\beta t} \quad (44)$$

where  $\beta$  is a complex variable:

$$\beta = \alpha + i\omega \quad (45)$$

By the Euler expansion of  $e^{\beta t}$ , another way to write Equations 43 and 44 is

$$x = x_0 e^{\alpha t} (\cos \omega t + i \sin \omega t) \quad (46)$$

$$y = y_0 e^{\alpha t} (\cos \omega t + i \sin \omega t) \quad (47)$$

An interpretation of  $\alpha$  and  $\omega$  is shown in Figure 21. The real part of  $\beta = \alpha$  is called the *growth or attenuation factor*. The imaginary part is the frequency of vibration. A positive real part means that the response to a disturbance grows in time. The growth factor is similar to the logarithmic mean decrement, which is common in vibration theory:

$$\alpha \tau = \ln \frac{x_{n+1}}{x_n} \quad (48)$$

where  $\tau$  = period of vibration  
 $x_{n+1}$  = amplitude at time  $n + 1$   
 $x_n$  = amplitude at time  $n$

Thus, the growth factor  $\alpha$  is a measure of the growth or decay of the journal to a small disturbance. A positive growth factor implies an instability.

The solutions to Equations 41 and 42 are obtained by substituting Equations 43 and 44, which produces the following:

$$\begin{bmatrix} (M\beta^2 + D_{xx}\beta + K_{xx}) & (D_{xy}\beta + K_{xy}) \\ (\beta D_{yx} + K_{yx}) & (M\beta^2 + \beta D_{yy} + K_{yy}) \end{bmatrix} \begin{Bmatrix} x_0 \\ y_0 \end{Bmatrix} = \{0\}$$

To obtain a solution, the determinant of the coefficient matrix must vanish. Expansion produces a polynomial in  $\beta$  that can be solved for the roots of  $\beta$ , which in turn provide the growth factors and frequencies of vibration.

It is possible to obtain a closed-form solution of Equations 41 and 42 for the critical mass and resulting orbital frequency. The critical mass  $M$  is defined as that mass above which an instability will occur. At the threshold of instability, the real part of  $\beta = \alpha$  goes to zero and  $\beta = i\omega$ .

Substituting into Equation 49, expanding the determinant and separating real and imaginary components produces the following equations:

$$M^2\omega^4 - \underbrace{M(K_{yy} + K_{xx})}_{A}\omega^2 + \underbrace{(D_{yx}D_{xy} - D_{xx}D_{yy})}_{B}\omega^2 + \underbrace{K_{xx}K_{yy} - K_{xy}K_{yx}}_{C} = 0 \quad (50)$$

$$\underbrace{M(D_{yy} + D_{xx})}_{D}\omega^2 + \underbrace{(D_{xy}K_{yx} + D_{yx}K_{xy} - D_{xx}K_{yy} - D_{yy}K_{xx})}_{E} = 0 \quad (51)$$

The two equations can be solved for  $M$  and  $\omega$ :

$$M = \frac{BED}{E^2 - AED + CD^2} \quad (52)$$

$$\omega = \sqrt{\frac{-(AED + E^2 + CD^2)}{BD^2}} \quad (53)$$

Thus, if the cross-coupled coefficients are known, it is possible to determine the critical mass and the orbital frequency. If the mass acting on the bearing exceeds or equals the critical value, then an instability will occur.

**Dynamic Stability of Various Bearing Types** Several parameters can be used to establish the stability characteristics of a particular type of bearing. The most significant is the critical mass, derived above. It is also possible to get some feel for stability from purely steady-state performances by examining the bearing attitude angle. The larger the attitude angle, the greater the cross-coupling influence and the worse the stability characteristics. Interpreting attitude angles, however, can prove misleading.

Figure 22 shows plots of the attitude angle  $\gamma$  versus the load parameter  $W$  for some of the different types of bearings previously described. The contradiction in these results is that the symmetric three-lobe bearing has higher attitude angles than the two-groove cylindrical bearing even though, as will be subsequently demonstrated, it has superior stability characteristics. The reason for the higher attitude angle is that the bearing is cavitating in the diverging region of the loaded pad, which results in a large shift in the journal. Whirl motion, however, is prevented by the accompanying lobes.

A more direct and accurate approach to establishing bearing stability is to determine the critical mass acting on the bearing. Figure 23 shows the results obtained for the fixed

## CENTRIFUGAL PUMPS

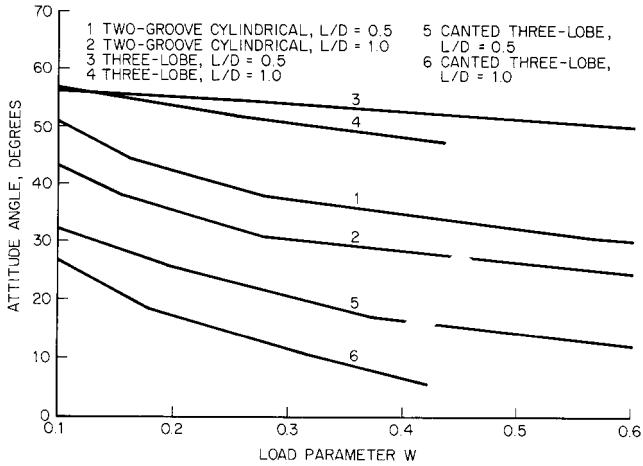


FIGURE 22 Attitude angle versus load parameter for various bearing types.

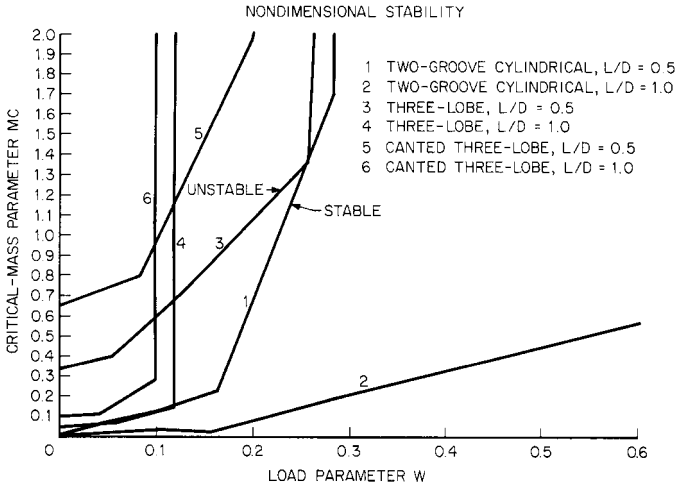


FIGURE 23 Critical mass versus load parameter for various bearing types.

bearing geometries previously discussed. For any particular bearing geometry, if the critical mass attributable to the bearing exceeds that of the data plotted, the bearing will be unstable. Thus, if the plotted point falls to the right of the bearing line, the bearing is stable; if it falls to the left, the bearing is unstable.

The critical mass is defined as follows:

$$M = m\omega Rc^3/24\mu L^5 \quad (54)$$

where  $M$  = nondimensional critical mass  
 $m$  = dimensional critical mass, lb · s<sup>2</sup>/in (kg · s<sup>2</sup>/mm)  
 $\omega$  = shaft speed, rad/s  
 $R$  = shaft radius, in (mm)  
 $c$  = bearing machined radial clearance, in (mm)  
 $\mu$  = lubricant viscosity, lb sec/in<sup>2</sup> (Pa · s)  
 $L$  = bearing length, in (mm)

An examination of the curves in Figure 23 clearly indicates the superiority of the canted three-lobe bearing and the inferiority of the cylindrical configuration.

EXAMPLE Consider a high-speed bearing for which

$N = 60,000$  rpm  
 $\omega = 60,000\pi/30 = 6283$  rad/s  
 $D = 1$  in (25.4 mm)  
 $L = 0.5$  in (12.7 mm)  
 $\mu = 1 \times 10^{-6}$  lb · s/in<sup>2</sup> ( $6.9 \times 10^{-3}$  Pa · s)  
 $C = 0.0005$  in (0.013 mm)  
 $w = 100$  lb (45.35 kg)

$$W = \frac{wC^2}{6\mu\omega RL^3} = \frac{(100)(0.0005^2)}{(6)(1 \times 10^{-6})(6283)(0.5)(0.5^3)} = 0.0106$$

The value of  $M$  is obtained from Figure 22 and indicated in Table 4 for the various bearing types considered. Dimensional units are also given. Table 4 clearly indicates that the lobe bearings can permit significantly more attributable mass than the cylindrical bearing can. If a symmetric rotor is being supported by two bearings, the cylindrical bearings would be unstable if half the weight of the rotor exceeded 14.7 lb (6.67 kg). The half weights go to 258 lb (117 kg) and 501 lb (227.2 kg) for the symmetric three-lobe and canted three-lobe bearings, respectively. No mention has been made of the tilting-pad bearing because, for all practical purposes, these bearings are always stable.

## OPERATING CONDITIONS THAT AFFECT BEARING STABILITY

**Cavitation** Figure 1 shows a pressure distribution in a journal bearing. Positive pressure is generated in the converging wedge because the journal is pumping fluid through a restriction. On the downstream side of the minimum film thickness, the journal is pumping fluid out of a diverging region. In this region, the pressure decreases. Either the pressure becomes negative, which is defined as pressure below the ambient pressure,

TABLE 4 Stability Comparison Chart

Bearing type	$M$	$m$ , lb · s <sup>2</sup> /in (kg · s <sup>2</sup> /mm)	$w'$ , lb (kg) <sup>a</sup>
Two-groove cylindrical	0.02	0.038 ( $6.79 \times 10^{-4}$ )	14.7 (6.7)
Symmetric three-lobe	0.85	0.668 ( $11.9 \times 10^{-3}$ )	257.9 (117.1)
Canted three-lobe	0.68	1.299 ( $23.2 > 10^{-3}$ )	501.4 (227.6)
		$m = \frac{24M\mu h^5}{\omega Rc^3} = \frac{M(24)(10^{-6})(0.5^5)}{(6283)(0.5)(0.0005^3)} = 1.91M$	

<sup>a</sup>The  $w'$  represents the maximum mass in weight units that could act on the bearing.



or the film cavitates and decreases to atmospheric pressure as the lubricant releases entrapped air.

With respect to stability, cavitation is a more desirable condition than the development of negative pressure. From an examination of Figure 1, it can be seen that the negative pressure pulls the journal in an orthogonal direction and increases the cross-coupling. The more eccentric the bearing, the larger the negative pressure or cavitated region.

In lightly loaded bearings that are pressure-fed, negative pressures can occur because pressures in the divergent region have not approached atmospheric pressure. Cavitation does not occur, and the bearing is prone to instability. Thus, the feed pressure and load on a bearing are two additional parameters that affect stability.

Lobe bearings are often used because of their excellent antiwhirl characteristics. Figure 9 earlier showed two types of lobe bearings: symmetric and canted. The symmetric lobe bearing is designed so that, in the concentric position, the minimum film thickness occurs at the center of each lobe. Note that this permits a region of converging film followed by a region of diverging film. Thus, depending upon the ambient pressure, it is possible to have negative pressures in a symmetric lobe bearing. Under very high ambient conditions, a symmetric lobe bearing can go unstable.

The canted lobe bearing is designed to have a completely converging wedge and positive pressure throughout its arc length. Its stability characteristics are superior to those of the symmetric lobe bearing. Its steady-state characteristics are also superior.

**Hybrid Bearings** At times, externally pressurized bearings are resorted to for stability improvements. The philosophy is that externally pressurized bearings are not subject to high attitude angles, as is the case with hydrodynamic journal bearings. Although this is generally true, hybrid bearings can still be subject to considerable cross-coupling. Figure 11 showed a schematic arrangement of a hybrid bearing. Oil is fed through restrictors from an external source into pocket recesses. From there, it exits into the clearance region between recesses. Lubricant is also pumped into and out of recesses by the rotating shaft by a viscous drag in the same manner as with a purely hydrodynamic bearing.

Consider recess 2 in Figure 11. Oil is pumped from the shaft via a converging wedge, and it augments the pressure in the recess provided by the external system. The net result is a higher pressure in the bearing domain covered by recess 2 than would occur without rotation. Now consider recess 3. Here the journal is pumping fluid out of the recess into a diverging film, so that the hydrodynamic action tends to reduce the pressure in this recess domain. By similar reasoning, it can be shown that recess 4 operates at a lower pressure than recess 1. The net result of these variations in pressure due to rotation is that cross-coupling forces are introduced and the hybrid bearing may not prevent instability.

## BEARING MATERIALS AND FAILURE MODES

---

**Materials** The most common material used for oil-lubricated fluid film bearings is babbitt. Tin- and lead-based babbitts are relatively soft materials and offer the best insurance against shaft damage. They also enable embedded dirt and contaminants without significant damage.

Two types of babbitts are in common use. One has a tin base (86 to 88 percent), with about three to eight percent copper and four to 14 percent antimony. The other has a lead base with a maximum of 20 percent tin and about 10 to 15 percent antimony. The remainder is principally lead. The physical properties of babbitt are shown in Table 5. The primary limitations of babbitt are operating temperature (300°F [140°C] max) and fatigue strength. The chemical composition of various babbitt alloys are indicated in Table 6.

Tin-based babbitts have better characteristics than lead-based babbitts; they have better corrosion resistance, are less likely to wipe under poor conditions of lubrication, and can be bonded more easily than lead-based materials. Because of cost considerations, however, lead-based babbitts are widely used. The more widely used is the SAE 15 alloy containing one percent arsenic (refer to Table 6).

**TABLE 5** Properties of Bearing Alloys

Bearing material	Brinell hardness at room temperature	Brinell hardness at 30°F (17°F)	Minimum Brinell hardness of shaft	Load carrying capacity, lb/in <sup>2</sup> (kg/m <sup>2</sup> )	Max operating temperature, °F (°C)
Tin-based babbitt	20–30	6–12	150 or less	800–1500 ( $5.62 \times 10^5 - 10.55 \times 10^5$ )	300 (149)
Lead-based babbitt	15–20	6–12	150 or less	800–1200 ( $5.62 \times 10^5 - 8.44 \times 10^5$ )	300 (149)

SOURCE: Ref. 8

**TABLE 6** Composition<sup>a</sup> Percentages of Babbitts with SAE Classifications of 11 to 15

Element	SAE No. (Similar ASTM Spec.)				
	11 (None)	12 (B23, alloy 2)	13 (None)	14 (B23, alloy 7)	15 (B23, alloy 15)
Tin (mm)	86.0	88.2	5.0–7.0	9.2–10.8	0.9–1.2
Antimony	6.0–7.5	7.0–8.0	9.0–11.0	14.0–16.0	14.0–15.5
Lead	0.5	0.5	Remainder	Remainder	Remainder
Copper	5.0–6.5	3.0–4.0	0.5	0.5	0.5
Iron	0.08	0.08	—	—	—
Arsenic	0.1	0.1	0.25	0.6	0.8–1.2
Bismuth	0.08	0.08	—	—	—
Zinc	0.005	0.005	0.005	0.005	0.005
Aluminum	0.005	0.005	0.005	0.005	0.005
Cadmium	—	—	0.05	0.05	0.05
Others	0.2	0.2	0.2	0.2	0.2

<sup>a</sup>The percentage of minor constituents represents limiting values except as noted.SOURCE: *SAE Handbook*, Society of Automotive Engineers. New York, 1960, p. 201.

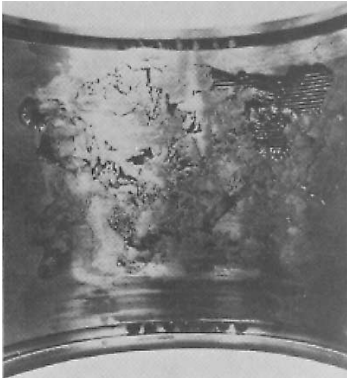
Tin-based babbitts do not experience as many corrosion problems as lead-based babbitts. SAE 11 babbitts (containing eight percent antimony and eight percent copper) are used extensively for industrial applications.

Babbitts are bonded to a backing shell of another material, such as steel or bronze, because they are not a good structural material. The thinner the babbitt layer, the greater the fatigue resistance. In automotive applications where resistance to fatigue is important, babbitt thickness is from 0.001 to 0.005 in (0.02 to 0.12 mm). For pump applications, the thickness varies from  $\frac{1}{32}$  to  $\frac{1}{8}$  in (0.8 to 3 mm). The thicker layers provide good conformity and embedability.

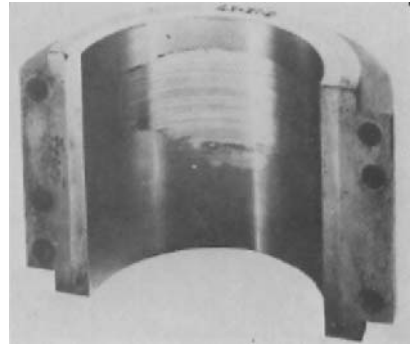
**Failure Modes** The failure modes most commonly found are fatigue, wiping, overheating, corrosion, and wear.

Fatigue occurs because of cyclic loads normal to the bearing surface. Figure 24 shows babbitt fatigue in a 7-in (178-mm) diameter journal bearing from a steam turbine.

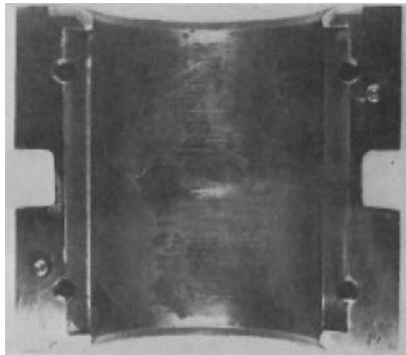
Wiping results from surface-to-surface contact and smears the babbitt, as shown in Figure 25. The usual causes of wiping are a bearing overload, insufficient rotational speed to form a film, and loss of lubricant.



**FIGURE 24** Babbitt fatigue in a 7-in (178-mm) diameter turbine bearing. (Westinghouse Electric Corp. *Photo originally reproduced in Ref. 8, p.18–19.*)



**FIGURE 25** Bearing wipe on a 3-in (76-mm) diameter bearing due to temporary loss of lubricant. (Westinghouse Electric Corp. *Photo originally reproduced in Ref. 8, p.18–25*)



**FIGURE 26** Corrosion on a 5-in (127-mm) diameter, lead-based babbitt bearing. (Westinghouse Electric Corp. *Photo originally reproduced in Ref. 8, p. 18–21*)

Overheating is manifest by discoloration of the surface and cracking of the babbitt material. Corrosion is failure by a chemical action. It is more common with lead-based babbitts, which react with acids in the lubricant. Figure 26 shows corrosion damage for a 5-in (127-mm) diameter, lead-based babbitt bearing.

Wear results from contaminants in the film and is evidenced by scoring marks that may be localized or persist around a large circumferential region of the bearing.

## REFERENCES

- <sup>1</sup>Fuller, D. D. *Theory and Practice of Lubrication for Engineers*. Wiley, New York, 1956.
- <sup>2</sup>Castelli, V. and W. Shapiro. "Improved Method of Numerical Solution of the General Incompressible Fluid-Film Lubrication Problem." *Trans. ASME, J. Lub. Technol.*, April, 1967, pp. 211–218.

<sup>3</sup>Castelli, V., and J. Pirvics. "Review of Methods in Gas-Bearing Film Analysis." *Trans. ASME, J. Lub. Technol.*, October 1968, pp. 777-792.

<sup>4</sup>Pinkus, O. and B. Sternlicht. *Theory of Hydrodynamic Lubrication*. McGraw-Hill, New York, 1961.

<sup>5</sup>Ng, C. W. and C. H. T. Pan. "A Linearized Turbulent Lubrication Theory." *Trans. ASME, J. Basic Eng.*, Series D, Vol. 87, 1965, p. 675.

<sup>6</sup>Elrod, H. G. and C. W. Ng. "A Theory for Turbulent Films and Its Application to Bearings." *Trans. ASME, J. Lub. Technol.*, July 1967, p. 346.

<sup>7</sup>Shapiro, W., and R. Colsher. "Dynamic Characteristics of Fluid Film Bearings." *Proc. Sixth Turbomachinery Symposium*, sponsored by the Gas Turbine Laboratories, Department of Mechanical Engineering, Texas A&M University, College Station, Texas, December 1977.

<sup>8</sup>O'Connor, J. I., J. Boyd, and E. A. Avallone. *Standard Handbook of Lubrication Engineering*. McGraw-Hill, New York, 1968.

## 2.2.6 CENTRIFUGAL PUMP MAGNETIC BEARINGS

GRAHAM JONES  
LARRY HAWKINS  
PAUL COOPER

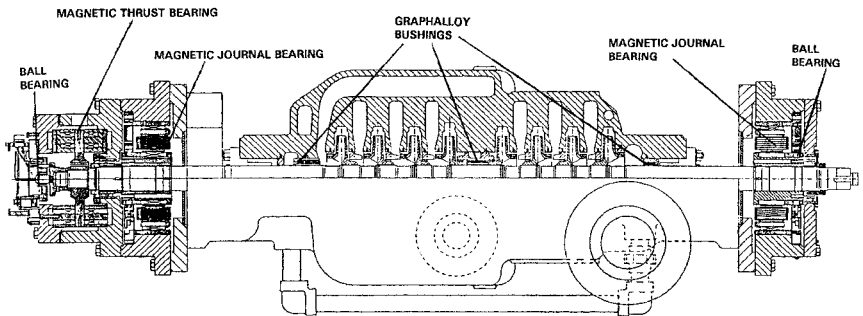
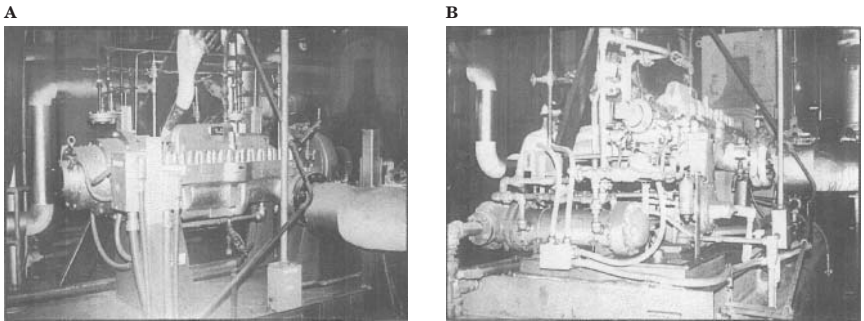
Magnetic bearings maintain the rotor of a pump in suspension through the forces of attraction of a magnetic circuit. Thus, although they bear up the weight and hydraulic loads of the impellers and the shaft, they are not really bearings in the traditional sense of the rotating and stationary surfaces bearing on one another. The supporting magnet circuit for each bearing includes stationary magnets in a stator surrounding the shaft, a laminated rotor that fits on the shaft, and the shaft itself. The stator consists of electromagnets in the traditional heteropolar design, and if a homopolar design is employed, permanent magnets can be added. Sensors monitor the position of the shaft and signal a controller to adjust the magnetic loads to keep the shaft to within about 0.001 in (25  $\mu\text{m}$ ) of the desired position.

Magnetic bearings are found in small, high-speed turbomachinery such as high-speed, multistage, axial-flow turbomolecular vacuum pumps<sup>1</sup>. They were introduced into large turbomachinery in the early 1980s, mainly in gas compressors and turboexpanders. Their use and acceptance has grown slowly but steadily since then<sup>2</sup>. Pump applications of a significant size have appeared and have confirmed the general position that magnetic bearings can provide a technically sound bearing with maintenance and operating advantages, including zero wear. However, due to the technical complexity of magnetic bearing systems, the economies of scale associated with production quantities are required to make these systems affordable.

Two representative magnetic-bearing-equipped pumps are summarized in Table 1. One is a multistage boiler feedwater pump<sup>3-6</sup> and the other a single-stage double-suction hydrocarbon process pump<sup>7</sup>. The multistage pump was retrofitted with magnetic bearings (as shown in Figure 1) and is shown in Figure 2, together with another identical pump that still contains the oil-lubricated bearings—both installed in an electric generating station. The magnetic-bearing pump is not encumbered with the usual complexity of a bearing lubrication system.

**TABLE 1** Example of magnetic-bearing-equipped pumps

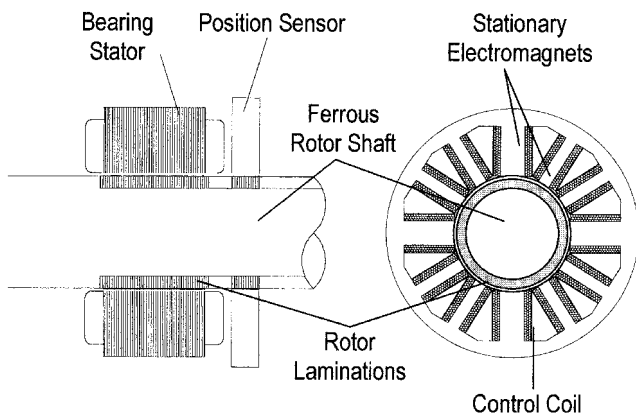
Parameter	Multistage Pump	Single-Stage Pump
Power, hp (MW)	610 (0.46)	800 (0.6)
Rated speed, rpm	3,580	1780
Shaft weight, lb (kg)	520 (236)	732 (332)
Radial bearing design load, lb (kN)	800 (3.6)	Thrust end: 930 (4.1) Drive end: 1,415 (6.3)
Thrust bearing design load, lb (kN)	4,000 (17.8)	4,000 (17.8)
Number of stages	8	1

**FIGURE 1** Magnetic bearing configuration in multistage pump<sup>6</sup>**FIGURE 2** Multistage pumps installed in boiler feed service [610 hp (0.46 MW)]: a) pump with magnetic bearings; b) the same pump with oil-lubricated bearings. (Flowsolve Corporation)

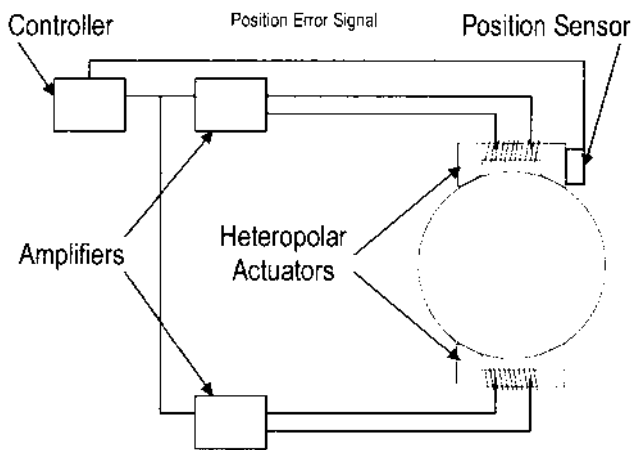
## MAGNETIC BEARING PRINCIPLES

**How Magnetic Bearings Work** In an active magnetic bearing system, a stator composed of an array of stationary magnets, or electromagnetic coils, interacts with a ferrous rotor (or a ferrous sleeve on a non-ferrous rotor) so as to suspend the shaft in a magnetic field (see Figure 3).

The position of the shaft is maintained dynamically through a continuous feedback system which comprises a position sensor, a controller, and an amplifier system (see Figure 4). Typically there are two radial bearings and one thrust bearing for a complete sys-



**FIGURE 3** Typical radial electromagnetic bearing. (Axial thrust bearings have the stator coils arranged in a disk configuration, a ferrous rotating disk being supported in the resulting magnetic circuit.)

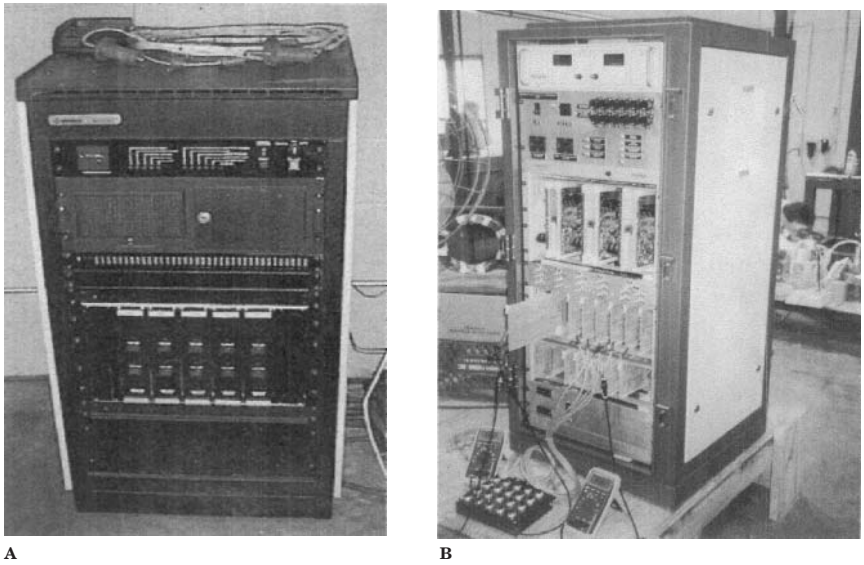


**FIGURE 4** Typical system control loop

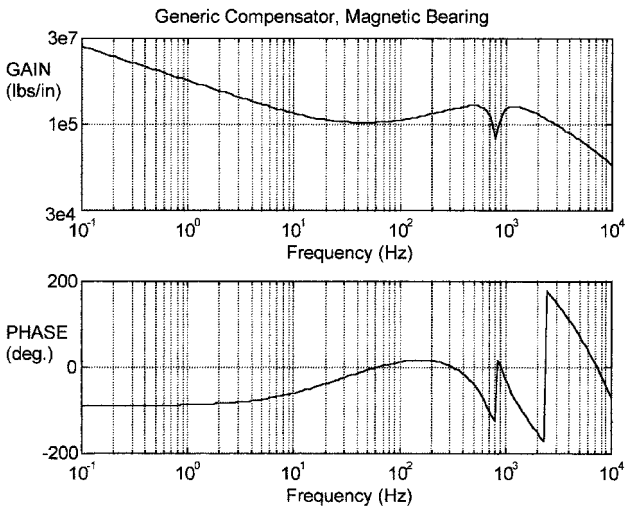
tem. This system is tuned to the required characteristics of the pump, through a digital or analog controller (Figure 5), with the capability of adjusting the bearing stiffness and damping as a function of pump speed. Alarms and trips can be set at any required rotor offset or bearing load to provide the operator with warnings or to trip the drive unit as necessary. Figure 6 illustrates a typical bearing transfer function, showing a statically stiff bearing, with a dynamic stiffness over the operating speed range designed to meet the rotor dynamics requirements of the unit. The stiffness is then rolled off above the operating range to avoid excitation of higher modes in the rotor or stator.

Controller redundancy can be provided with the control loops switching to backup units upon sensing a failure. Also, backup power supplies should be provided, either through alternate sources or a battery system. Typically the power required is only one or two kW or less.

A catcher (also known as auxiliary, backup, or touchdown) bearing (indicated in Figure 1) is required to protect the rotor stator interface during maintenance and in the event of



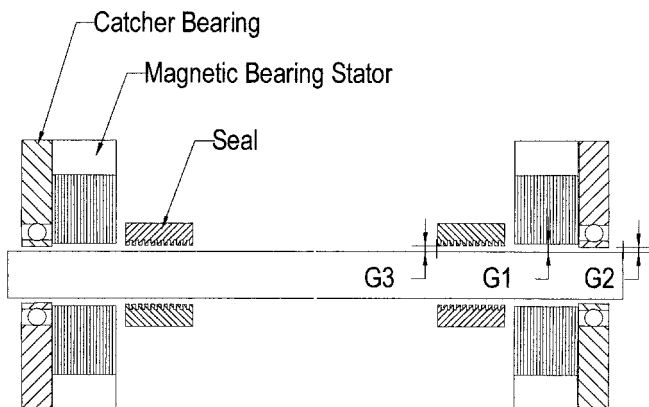
**FIGURE 5** Controllers for magnetic bearings, containing rectifier and amplifiers: a) digital controller; b) analog controller



**FIGURE 6** Bearing transfer function

loss of power or a severe transient beyond the force capability of the bearing. Typically, the catcher bearing is designed for 5 to 20 lifetime drops from full speed, and will be a readily replaceable rolling element or sleeve bearing. The pump of Figures 1 and 2 has rolling element catcher bearings. The radial clearances  $G1$  (see Figure 7) between the magnetic





**FIGURE 7** Clearance arrangement: Seal ring clearance G3 is greater than catcher-bearing clearance G2, but is less than magnetic-bearing clearance G1.

bearing stator and rotor are of the order of 20 to 40 mil (0.5 to 1 mm), and those in the catcher bearings (G2) are about half of that value.

**Reasons for Using Magnetic Bearings** There are several reasons to use magnetic bearings in pumps. While any one of these reasons may not be sufficient justification on its own, together they can provide a strong justification.

Reliability is a key incentive. The components of a magnetic bearing are essentially the same components as are found in an electric motor: laminations and coils. Because no wear is involved due to the lack of contact, these components will generally last the life of the equipment involved. Thus maintenance of a magnetic bearing system is transferred from mechanical components inside the pump to the external controller, which has plug-in card replacement maintenance. Pump reliability is therefore improved, whereas repair times and costs are reduced.

Reduced power consumption is a second advantage, with the elimination of all losses associated with fluid film bearings and oil pumping equipment. This is replaced by the smaller power requirements of the bearing controller. Further, if the lifting force is supplied by a permanent magnet, supplemented by an active control circuit, this power requirement can be even smaller.

The ability to submerge the bearing in the pump fluid is a major advantage that allows the outboard mechanical seal to be eliminated, thereby eliminating maintenance and replacement of this seal<sup>8</sup>. [This was not done for the pumps of Table 1 (and Figures 1 and 2), because in both cases magnetic bearings were retrofitted to existing machines.]

More indirect savings are also possible in two other areas. Rotor dynamics can be controlled through the ability to adjust stiffness and damping as a function of pump speed, allowing higher imbalance without the need for shutdown. The diagnostic output inherent in the information provided in the controller can be fed into the overall plant operating system and the short-term and long-term health of the pump and the system can be monitored. This is done by inferring seal wear, transient hydraulic loads, and so on.

The actual figures for the savings possible due to the previous advantages are very pump- and system-specific, and general numbers are not very useful. Reference 9 has developed methodology for considering the economic effect of the types of advantages given.

**Main Types of Magnetic Bearings and Their Selection** There are two main types of magnetic bearings: passive and active. Passive bearings rely only on permanent magnets in repulsion and provide low stiffness, low damping, and no ability to control either of these parameters. Passive bearings are not applicable to pumps for this reason.

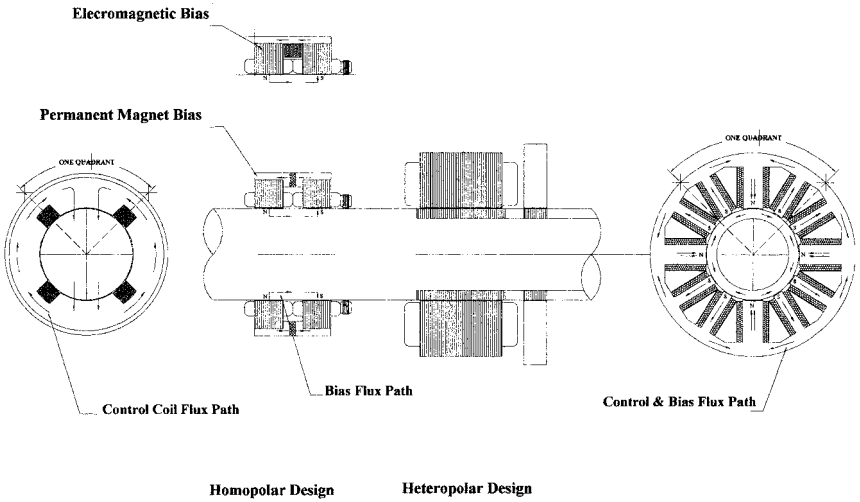


FIGURE 8 Heteropolar and homopolar bearings

Active bearings using the feedback system previously described are essential for pump applications. Within the active bearing systems are the options of heteropolar and homopolar and of electromagnetic and permanent magnet bias. The principles of the heteropolar and homopolar approaches are shown in the Figure 8.

The main difference between the two types is that in the heteropolar design, the bias and control flux flow in the same magnetic circuit radially through the rotor, whereas in the homopolar design the bias flux flows axially along the rotor and only the control flux flows radially through the rotor.

The homopolar design has two options for providing the bias flux for the bearing system<sup>10</sup>. One is to use an electromagnetic effect, and the other is to use a permanent magnet. The permanent magnet generation in the homopolar configuration results in a more linear relationship between force and distance. In a simple magnetic circuit, the attraction force of a magnet on a ferromagnetic target decreases as the square of distance (the target cuts  $\frac{1}{4}$  as many flux lines at twice the distance). With the permanent magnet in a homopolar circuit, the effect of the air gap is therefore reduced.

**DESIGN CONSIDERATIONS**

**Design Loads** The specification of a magnetic bearing requires a different approach to that required for a conventional bearing system. This section identifies the key areas where these differences occur.

The rotor can move considerably within the magnetic bearing and catcher bearing clearances, typically up to 10 mil (0.25 mm), before any contact is involved. Thus the clearances G3 in the internal ring-seal system (see Figure 7) become the key controlling parameter in setting the bearing clearance design limits and in the degree of motion permitted during transients. Thus, very early in the design process, the magnetic bearing clearances, catcher bearing clearances, and sealing-ring clearances must be optimized with due consideration for manufacturing tolerances and assembly concerns.

Synchronous filters or open-loop control methods can be used to handle imbalance loads so that the degree of imbalance acceptable (based on allowable bearing loads and shaft motion within the catcher bearing clearances) can often be significantly greater than in conventional bearings.

There is an area where careful analysis is needed for each new pump configuration. A conventional bearing, if overloaded, will accept the load with a higher wear rate, but a magnetic bearing has a sharp cut-off at the point where the flux saturation level is reached. At that point, any additional load will be transferred to the catcher bearing. Thus it is important to include all loads in the design specification, with the appropriate margins. All applications to date have generally shown a) that there are loads which were mistakenly considered to be insignificant, or b) that the values of the loads were underestimated due to lack of knowledge.

Magnetic bearings also must be carefully designed to handle transient loads, some of which may occur only once in a lifetime. Two approaches can be taken. One is to over-design the bearing to handle the load without contacting the catcher bearing; the other is to allow momentary contact with the catcher bearing. Examples of these types of loads are hydraulic loads, seal touchdown loads, system loads such as water hammer, valve operation, pump switchover, pump to driver alignment loads, and seismic loading.

**Rotordynamics Considerations** Magnetic bearings have the capability to control the rotor dynamics of a pump very effectively. If the pump is running below its first flexible mode, this is usually straightforward. If the pump has to traverse a flexible mode, the position of the bearings and the position sensor must be such that the modes can be recognized by the position sensor, and the bearings can exert a positive restoring force to control the mode. That is, the position sensors and bearings must not be positioned at or close to a node and certainly not positioned on opposite sides of a mode. Thus, rotordynamics considerations should be taken care of very early in the configuration of the system.

The two typical rigid body modes are shown in Figure 9. The location of the bearing and position sensor is not usually an issue for these modes, but the flexible modes require that the position sensor and bearing be positioned in such a way that the rotor deflection can be measured and the bearing can exert the necessary restoring force and damping to control the mode.

Magnetic bearing controllers are programmed with a transfer function designed specifically for the pump. This transfer function, or control algorithm, provides the necessary stiffness and damping at all operating speeds to control the rotor as previously described.

The key requirements of the transfer function are that it

- Provides correct damping and stiffness to handle the rotor rigid body modes
- Provides sufficient force with the appropriate control bandwidth to handle the rotor flexible modes below the maximum operating speed

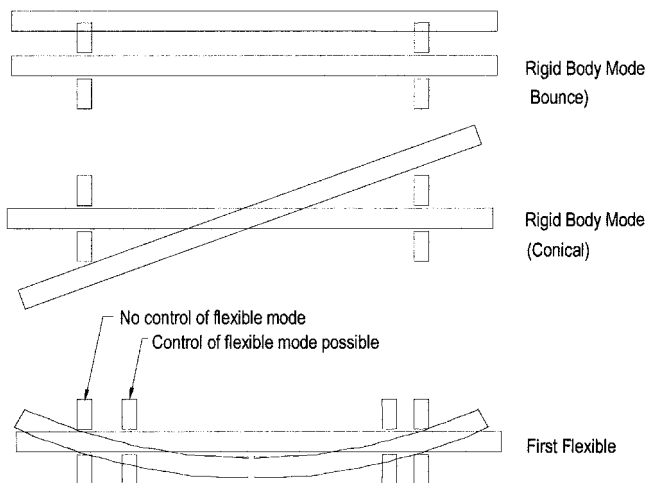


FIGURE 9 Flexible mode design considerations

- Does not excite any rotor modes above the maximum operating speed
- Does not excite any stator vibration modes at any frequency
- Takes into account the stiffness and damping contribution from wear rings and inter-stage annular seals

**Auxiliary or Catcher Bearings** However reliable magnetic bearings become, a landing surface for maintenance will be required. Further, designing a bearing that will take all transient loads without any possibility of overload will usually result in over-sized and costly bearings. Hence catcher, bearings are expected to be required. The design limits for catcher bearings are usually established by calculating the forces that will result from a drop at operating speed.

For applications running at significant speeds, a non-linear analysis is required to determine the motion and loading on the bearing during such a drop. The key design considerations are impact loads, heat generation during the rundown, and the response to imbalance if, when running on the catcher bearings, any critical speeds have to be traversed.

Rolling element bearings have typically been used as catcher bearings; however, sleeve bearings and bushings have been used in several applications, and are better suited to a submerged application.

## MAGNETIC BEARING SIZING

The fundamental magnetic bearing sizing problem is to define the pole area at the bearing air gap that is necessary to achieve the desired force capacity without saturating the selected pole materials. Given the pole area, the minimum stator outside diameter and maximum rotor inside diameter can be determined using simple algorithms to ensure that no other part of the magnetic circuit saturates. The stator geometry must also include sufficient volume for the control and bias coils.

**Approximate size and load capability** Table 2 contains rough approximations for the dimensions of magnetic bearings. (Refer to Figure 1.) These are based on the experience with the pumps of Table 1. Also included are the unit load capabilities, which are given a) for radial bearings in terms of radial load  $F_r$  divided by the projected area  $DL$  of the active pole area of the bearing at the air gap, and b) for axial thrust bearings in terms of the axial load  $F_z$  divided by the active pole area of the runner disk between the inner diameter  $D_i$  and the outer diameter  $D_o$ . These approximations provide the designer and user with an idea of the design configuration of a magnetic-bearing-equipped pump. The

**TABLE 2** Approximate magnetic bearing sizing relationships

Sizing Parameter	Heteropolar	Homopolar
<i>Radial Bearings</i>		
a) Dimensions, in multiples of the shaft diameter		
Air gap diameter, $D$	2	1.5
Stator outer diameter	4	3
Overall axial length	2	1.5
Active axial length of poles at air gap, $L$	0.9	0.8
b) Unit load capability, $F_r/DL$ , lb/in <sup>2</sup> (MPa)	40 (0.28)*	60 (0.41)
<i>Axial Thrust Bearings</i>		
a) Diameter ratio $D_j/D_o$ of active pole area	0.5	0.5
b) Unit load capability, $F_z / [\pi(D_o^2 - D_i^2)]$ , lb/in <sup>2</sup> (MPa)	50 (0.34)*	70 (0.48)

\*Higher with special lamination material

low unit loads of magnetic bearings result in more space being needed for them in comparison to conventional bearings.

**Theory of One-Dimensional Sizing** To perform more accurate, in-depth sizing, the theory of both heteropolar and homopolar magnetic bearings is applied. Magnetic bearing sizing and geometry programs normally use simple one-dimensional magnetic circuit theory to obtain initial sizing and perform design iterations. This initial sizing is then followed up with design analysis using 2D or 3D magnetic FEA analysis to verify the design. The basis of the classic one-dimensional sizing for a magnetic bearing is discussed next, first for the heteropolar bearing and then for the homopolar bearing.

#### HETEROPOLAR BEARING

- a. *Magnetic circuit*—The basic magnetic circuit equation, derived from Ampere's Loop Law, is

$$MMF = \Phi \mathcal{R} \quad (1)$$

where  $MMF$  = magnemotive force

$\Phi$  = magnetic flux

$\mathcal{R}$  = path reluctance

A sketch of one quadrant (one electromagnet) of a heteropolar bearing is shown in Figure 10.

Assuming the air gap area and path areas are equal, Eq. 1 becomes

$$2Ni = BA \left( \frac{g}{\mu_o A} + \frac{g}{\mu_o A} + \frac{l_{stat}}{\mu_o \mu_r, stat A} + \frac{l_{rot}}{\mu_o \mu_r, rot A} \right) \quad (2)$$

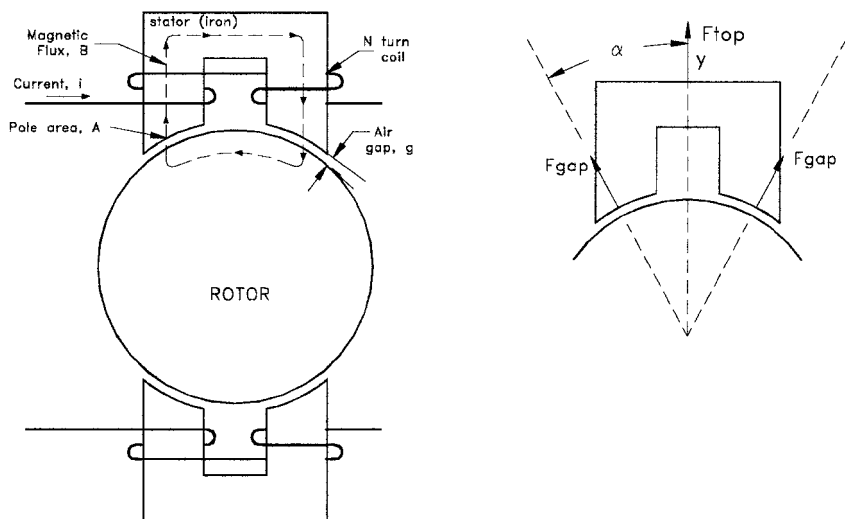


FIGURE 10 Simple electromagnetic circuit for one quadrant of a heteropolar magnetic bearing

Where  $N$  = number of turns per pole

$i$  = coil current

$B$  = magnetic flux density

$A$  = pole area

$g$  = air gap

$\mu_o$  = permeability of free space

$\mu_r$  = relative permeability

$l$  = iron path length

If the iron permeability is high relative to the air gap ( $\mu_{r,rot}, \mu_{r,stat} \gg \mu_o$ ), the iron reluctance terms are insignificant and the following equation can be obtained for the flux:

$$B = \frac{Ni\mu_o}{g} \quad (3)$$

b. *Force calculation*—The basic force equation for an air gap is

$$F_{gap} = \frac{B^2 A}{2\mu_o} \quad (4)$$

This equation assumes negligible leakage and fringing and that the flux density is uniform in the air gap. The combined vector force along the center of the bearing for the two air gaps of the top magnet is

$$F_{top} = 2F_{gap} \cos \alpha \quad (5)$$

Substituting from Eq. 4 gives

$$F_{top} = \cos \alpha \frac{B^2 A}{\mu_o} \quad (6)$$

If the saturation flux density,  $B_{sat}$ , of the iron material is used for  $B$ , Eq. 6 defines the load capacity as a function of pole area for a heteropolar magnetic bearing.

c. *Linearization of the force/current characteristic*—Substituting from Eq. 3 gives:

$$F_{top} = \cos \alpha \frac{A}{\mu_o} \left( \frac{Ni\mu_o}{g} \right)^2 = \cos \alpha AN^2 \mu_o \frac{i^2}{g^2} = k_1 \frac{i^2}{g^2} \quad (7)$$

$$k_1 = \cos \alpha AN^2 \mu_o$$

Thus, the force in a given magnet is proportional to the square of the current, a result that makes the bearing more difficult to control. Additionally, a single electromagnet can only apply a force in one direction (an attractive force). For these two reasons, opposed electromagnets are used together with a bias current (or flux) in each coil.

The current relationship is

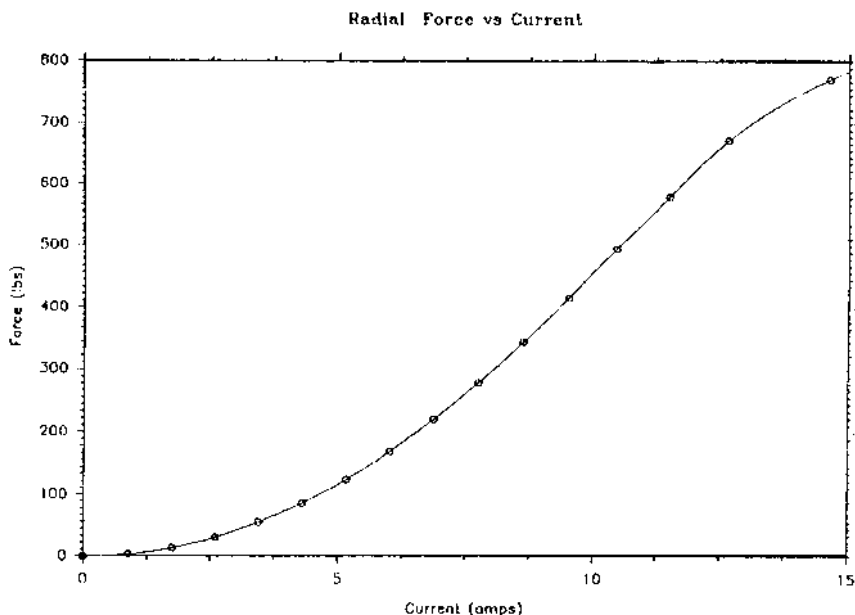
$$i = i_{bias} + i_{con}$$

to increase the force,

$$i = i_{bias} - i_{con}$$

to decrease the force.

The rotor may also be off-center in the air gap, described by



**FIGURE 11** Force versus current for radial bearing of multistage pump

$$g = g_0 - y \quad \text{top air gap}$$

$$g = g_0 + y \quad \text{bottom air gap}$$

Applying Eq. 7 to both top and bottom electromagnets yields

$$F_y = F_{top} - F_{bot} = k_1 \left[ \left( \frac{i_{bias} + i_{con}}{g_0 - y} \right)_{top}^2 - \left( \frac{i_{bias} - i_{con}}{g_0 + y} \right)_{bot}^2 \right] \quad (8)$$

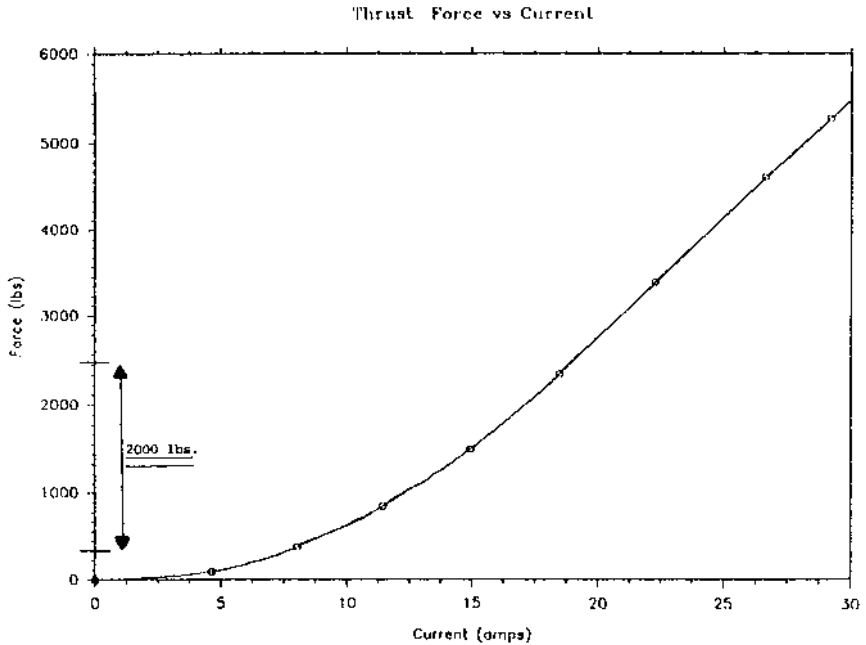
With the rotor centered ( $y = 0$ ), this can be reduced to

$$F_y = 4 \frac{k_1}{g_0^2} i_{bias} i_{con} \quad (9)$$

Thus the net bearing force is proportional to the control current. Figures 11 and 12 are examples of measured force versus current for radial and axial thrust bearings respectively. These measurements were made on the magnetic bearing of the multistage pump in Table 1 (refer to Figures 1 and 2).

- d. *Force constant and negative stiffness*—Eq. 8 can be also be linearized for small motion about the center ( $y \ll g_0$ ) by differentiating with respect to  $i_{con}$  and  $y$ , the two quantities in Eq. 8 that can change in normal operation of the bearing. The result is

$$F_y = -k_f i_{con} - k_n y \quad (10)$$



**FIGURE 12** Force versus current for axial thrust bearing of multistage pump

where

$$k_f = \frac{-4k_1 i_{bias}}{g_0^2} = \text{force constant or current stiffness} \quad (11)$$

$$k_n = \frac{-4k_1 i_{bias}^2}{g_0^3} = \text{negative stiffness or position stiffness} \quad (12)$$

The position stiffness is the passive stiffness of the bearing with a bias field but with no control current. The position stiffness is always negative, indicating that if the rotor is displaced from center, it will be pulled further from its equilibrium position if no control current is applied. The force constant defines the relationship of the control force to current (lb/amp or N/amp) with the bearing centered. It is also negative, indicating that applying a control current pulls the rotor from its centered position. Many practitioners use positive values for the force constant and the position stiffness as a matter of convenience. In this case, the minus signs in Eq. 10 become plus signs.

The control current is determined by the measured displacement,  $y$ , and the characteristics of an adjustable sensor/compensator/amplifier transfer function:

$$G_{con}(s) = \frac{i_{con}}{y} \quad (13)$$

Substituting Eq. 11 into Eq. 10 gives

$$Fy = -k_f G_{con}(s)y - k_n y \quad (14)$$



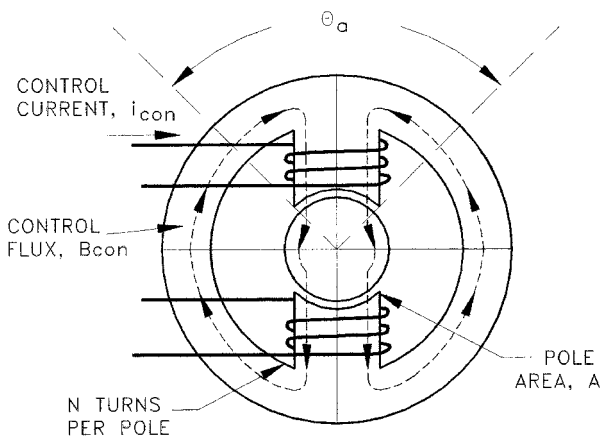


FIGURE 13 Control magnetic circuit for one axis of a homopolar magnetic bearing

The characteristics of the control transfer function  $G_{con}(s)$  are determined in order to stabilize the rotor/bearing system.

**HOMOPOLAR BEARING** In the homopolar bearing, a bias flux is used for linearization just as in the heteropolar bearing; however, the bias flux and control flux follow different paths. Additionally, the bias flux can be generated by either a permanent magnet (most common) or an electromagnetic coil. The use of a permanent magnet for bias reduces power consumption and makes the bearing more linear at large position offsets.

- a. *Magnetic control circuit*—The control circuit for one half of the homopolar bearing, shown in Figure 13, is across the top air gap, through the rotor, out the bottom air gap, and around the back iron.

When Eq. 1 is applied to this circuit, the result is similar to Eq. 2:

$$2Ni_{con} = B_{con}A \left( \frac{g}{\mu_o A} + \frac{g}{\mu_o A} + \frac{l_{stat}}{\mu_o \mu_{r,stat} A} + \frac{l_{rot}}{\mu_o \mu_{r,rot} A} \right) \quad (15)$$

Again, if the iron permeability is high relative to the air gap, this can be reduced to the following:

$$B_{con} = \frac{Ni_{con}\mu_o}{g} \quad (16)$$

- b. *Magnetic bias circuit*—The magnetic circuit equation for the bias circuit, shown in Figure 14, is

$$\frac{B_r l_m}{\mu_o \mu_{r,mag}} = B_{bias} A \left( \frac{g}{\mu_o A} + \frac{g}{\mu_o A} + \frac{l_m}{\mu_o \mu_{r,mag} A_m} \right) \quad (17)$$

Where  $B_r$  = residual induction of the magnet

$l_m$  = axial length of the magnet

$\mu_{r,mag}$  = relative permeability of the magnet ( $\cong 1.0$ – $1.05$ )

$A_m$  = magnet cross-sectional area per quadrant

With the magnet permeability assumed to be 1.0, this can be reduced to

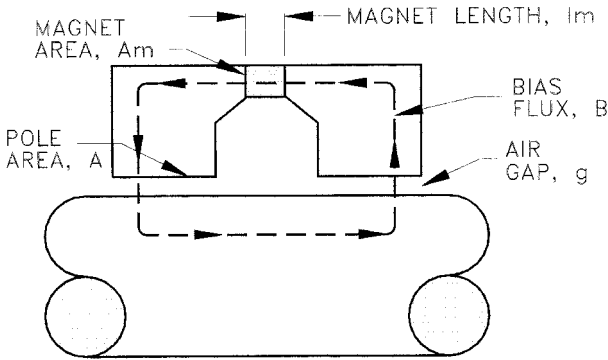


FIGURE 14 Bias magnetic circuit for one quadrant of a homopolar magnetic bearing

$$B_{bias} = \frac{B_r}{\frac{2g}{l_m} + \frac{A}{A_m}} \quad (18)$$

c. *Force calculation*—The basic force equation for an air gap is given by Eq. 4. In the homopolar bearing, the pole face covers a broader arc of the rotor than in the heteropolar bearing; therefore, the air gap force must be integrated over the surface to obtain the desired vector force,  $F_{top}$ . Both the front and back control stacks must also be included. The result is

$$F_{top} = 2C_g F_{gap}$$

Where:

$$C_g = \frac{2\sin(\theta_a/2)}{\theta_a} \quad (19)$$

This result assumes negligible leakage and fringing and that the flux density is uniform in the air gap. Substituting from Eq. 4 into Eq. 19 gives

$$F_{top} = C_g \frac{B^2 A}{\mu_o} \quad (20)$$

If the saturation flux density,  $B_{sat}$ , of the iron material is used for  $B$ , Eq. 20 defines the load capacity as a function of pole area for a magnetic bearing.

d. *Linearization of the force/current characteristic*—The air gap flux density in the homopolar bearing is the superposition of the bias and control flux. The control coils and permanent magnet polarity are arranged such that when the control flux adds to the bias in the top air gaps, the control subtracts from the bias in the bottom air gaps. Thus the net vertical force is

$$F_y = F_{top} - F_{bot} = \frac{C_g A}{\mu_o} [(B_{bias} + B_{con})_{top}^2 - (B_{bias} - B_{con})_{bot}^2] \quad (21)$$

This can be reduced in a similar manner as before to produce

$$F_y = \frac{4C_g A}{\mu_o} B_{bias} B_{con} \quad (22)$$

Substituting from Eq. 16

$$F_y = \frac{4C_g AN}{g} B_{bias} i_{con} \quad (23)$$

Thus the control force is proportional to the control current as desired.

e. *Force constant and negative stiffness*—The expression given in Eq. 10 for the heteropolar bearing also applies to the homopolar bearing:

$$F_y = -k_f i_{con} - k_n y \quad (24)$$

The definition of the force constant is

$$k_f = \frac{-4C_g AN B_{bias}}{g_0} = \text{force constant or current stiffness} \quad (25)$$

The expression for negative stiffness is not easily reducible to analytical form due to the complexity of the bias circuit. However, the existence of the permanent magnet in the bias flux path as a fixed and large reluctance improves the linearity of this bearing for off-center operation. Eqs. 13 and 14 for the heteropolar bearing apply to the homopolar bearing as well.

## INSTALLATION AND TUNING

---

**Mechanical Installation** Magnetic bearings have the advantage that they can be set, by adjusting offsets in the controller, to center the rotor on the magnetic bearing stator, the catcher bearing, the seals, or any other mechanical reference in the pump. The rotor can even be offset vertically to cancel the effect of gravity, thus reducing static power requirements to near zero. Careful consideration is needed during design to decide which is the best approach.

The position sensors in the bearings can also be used to measure the clearances between the rotor and any physical stops such as a sealing ring, without disassembly.

**Tuning** The rotor dynamics analysis performed during the early design stage will be used to determine the initial controller compensation, which will have a transfer function matched to the pump requirements. During initial testing, this transfer function will have to be adjusted to match the as-built dynamics of the rotor and support structure.

Normally the rotor will be accurately modeled and little change will be needed. If there are shrink fits or bolted joints, there may be some stiffness variation from the theoretical model. This may require on-site controller compensation adjustment. However, the stator is often a complex structure, and adjustments may be needed to avoid the excitation of stator modes.

## DIAGNOSTICS AND USER INTERFACE

---

**Diagnostic Capabilities** The controller, in order to function, must analyze a continuous stream of information on the shaft location in each of the five control axes, two for each radial bearing and one for the thrust bearing. This information can be accessed for external diagnostic use, as can the corresponding information on bearing current, from which can be inferred the bearing load. This diagnostic information can be a very useful source of information on the health of the pump, its mechanical components, and on the system it is operating in.

**Interface Requirements** The magnetic bearing system controller can also be interfaced with the plant control system with the following type of logic:

- No drive unit start without levitation
- No delevitation at speed
- Rotor offset and bearing load alarms
- Rotor offset and bearing load driver trips, with possible time delay

## RELIABILITY AND MAINTENANCE

---

**Bearing Cartridges** As explained earlier, the reliability of the bearing stator and rotor components should be such as to provide lifetime service.

**Controller** The main life limiting component in the controller is likely to be the amplifier. In a redundant system, online replacement is possible without loss of levitation. In a non-redundant system, a preventative maintenance approach should be used for this component.

## OPERATING EXPERIENCE

---

**Multistage Boiler Feed Pump** The multistage pump of Table 1 (refer to Figure 1) was installed as one of three otherwise identical pumps (two in parallel, one standby) in an electric utility generating plant (refer to Figure 2). The objective was to show that magnetic bearings would work in a typical field application of a pump of significant power level. This project took the first step of replacing the conventional bearings in this 610 hp (0.46 MW) eight stage centrifugal pump, which were outboard of the pump itself, and replacing them with heteropolar active magnetic bearings without any major design changes<sup>6</sup>. This was seen as the first of two steps, the second being a project where the bearings would be submerged in the operating fluid, allowing one seal system to be replaced<sup>8</sup>.

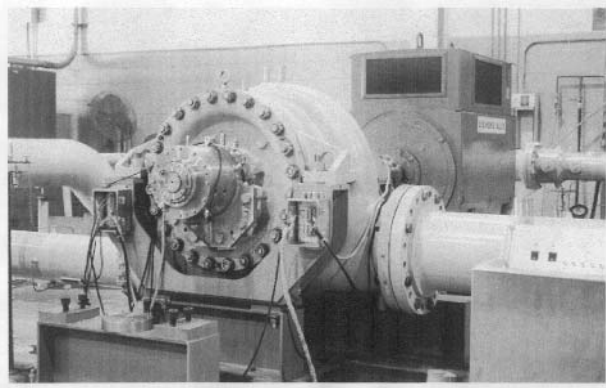
As with many magnetic bearing projects, the main lesson learned was that the transient bearing loads could not always be predicted ahead of time, and that the magnetic bearings gave very precise and important feedback of this information. Table 3 contains the design and field data. In this case, the 2500 lb (11 kN) transient load occurred when the plant underwent a suction pressure transient in which the available *NPSH* became so low that the first stage of this horizontally-opposed staging configuration (refer to Figure 1) apparently lost pressure rise completely<sup>6</sup>. The axial thrust of this stage was accordingly lost, destroying the intended axial hydrodynamic thrust balance of the pump. (See Sections 2.1 and 2.2.1.) Nevertheless, the conservative design of the thrust bearing enabled it to accommodate this load.

**Single-Stage Process Pump** The 800 hp (0.6 MW) single-stage double-suction process pump of size 8 × 26 (200mm × 660mm) of Table 1 was retrofitted with homopolar bearings<sup>7</sup>.

Closed-loop testing was conducted in the pump manufacturer's facility (see Figure 15). As indicated in Table 4, the results showed that a substantial operating margin exists for

**TABLE 3** Operating experience with multistage pump

Bearing	Expected Load, lb (kN)		Design Load, lb (kN)	Actual Load, lb (kN)	
	Steady	Transient		Steady	Transient
Radial	280 (1.2)	560 (2.5)	800 (3.6)	280 (1.2)	580 (2.6)
Axial	1,000 (4.4)	2,000 (8.9)	4,000 (17.8)	1,100 (4.9)	2,500 (11.1)



**FIGURE 15** Single-stage double-suction 10 × 26-size process pump [800 hp (0.6 MW)] with magnetic bearings. (Reference 7)

**TABLE 4** Design and experimental loads for the single-stage pump

Bearing	Expected Load, lb, (kN)	Design Load, lb (kN)	Actual Load, lb (kN)
Radial	953 (4.2)	1,430 (6.4)	1,450 (6.4)
Axial	1,000 (4.4)	4,000 (17.8)	2,100 (9.3)

the axial thrust bearing. Greater design capacity would provide the same margin with respect to radial loads.

The margins evident in Table 3 for the multistage pump may appear excessive, but until more operating knowledge about such pumps is acquired, it would appear that this degree of conservatism in designing magnetic bearings for pumps is merited.

## COSTS

Backed by the vision of complete magnetic suspension and the attendant benefits, magnetic bearing technology has been proven and demonstrated in pumping machinery. However, the major deterrent to further application of this technology is cost. Retrofitting the magnetic bearings to the multistage pump described above cost at least twice the price of the pump itself, and this included the analog controller, which accounted for about a third of the retrofit cost. Digital controllers, a later development, are one third the size and cost of analog controllers; this has significantly reduced the overall cost. Much of this overall cost is in the engineering of the magnetic bearings, which includes matching this system to the rotordynamic characteristics of the pump. Use of the same system in quantity production would reduce the cost by up to 80 percent.

## REFERENCES

1. *Marks Standard Handbook for Mechanical Engineers*. 9th ed. E. A. Avallone and T. Baumeister, eds., McGraw-Hill, 1987, pp. 3–56.
2. McCloskey, T., and Jones, G. “Electric Utility Applications for Active Magnetic Bearings.” *Proceedings of MAG ‘92*, Magnetic Bearings, Magnetic Drives and Dry Gas Seals Conference and Exhibition, University of Virginia, July 1992, pp. 3–18.

3. Cooper, P., McGinnis, G., Janik, G., Jones, G., and Shultz, R. "Application of Magnetic Bearings in a Multistage Boiler Feed Pump." *Proceedings of the Second International Symposium on Magnetic Bearings*, July 1990.
4. McGinnis, G., Cooper, P., Janik, G., Jones, G., and Shultz, R. "A Boiler Feed Pump Employing Active Magnetic Bearings." Presented at International Joint Power Generation Conference, Boston, MA, ASME, October 1990, ASME.
5. Cooper, P., and Jones, G. "Operating Experience, Including Transient Response, of a Magnetic-Bearing-Equipped Boiler Feed Pump." *Proceedings of MAG '92*, Magnetic Bearings, Magnetic Drives and Dry Gas Seals Conference and Exhibition, University of Virginia, July 1992, pp. 19–28.
6. Jones, G., and Penfield, S. Jr. "Magnetic Bearing Boiler Feed Pump Demonstration", Research Report EP89-39, Empire State Electric Energy Research Corporation, October 1992.
7. Brown, E., Thorp, J. M., Hawkins, L., and Sloteman, D. "Development and Application of a Homopolar, Permanent-Magnet-Bias Magnetic Bearing System for an API 610 Pump." *Saudi Aramco Journal of Technology*, Spring 1997, pp. 2–13.
8. Hanson, L., and Imlach, J. "Development of a Magnetic Bearing API Process Pump with a Canned Motor." *Proceedings of the Ninth International Pump Users Symposium*, Texas A&M University, March 1992, pp. 3–8.
9. "Guidelines for the Use of Magnetic Bearings in Turbomachinery." Prepared by Technology Insights, San Diego, California and published by the Electric Power Research Institute, February 1996.
10. Meeks, C. R., DiRusso, E., and Brown, G. V. "Development of a Compact, Lightweight Magnetic Bearing." *Proceedings of the 26th Joint Propulsion Conference*. AIAA/SAE/ASME/ASEE, Orlando, FL, 1990.

# SECTION 2.2.7 SEALLESS PUMPS

FREDERIC W. BUSE  
STEPHEN A. JASKIEWICZ

Sealless pumps are developed to eliminate the liquid leakage to the atmosphere that occurs from pumps that employ packing or mechanical seals. This leakage is usually toxic or dangerous to the environment. Sometimes the leakage is valuable. Eighty percent of the applications are for pressures below 200 lb/in<sup>2</sup> (13.8 bar) and below 250°F (120°C).

Sealless pumps are divided into two categories: magnetic drive pumps and canned motor pumps. The two categories compete against themselves in certain applications, but for the most part they each have their own market niche into which they are applied. Both have encapsulated inner driven mechanisms. On a magnetic drive pump (see Figure 5 in Section 2.2.7.1), the impeller is mounted to an inner magnet carrier. The inner and outer magnetic carriers are sealed by what is called a shell, which contains pump internal pressure. On a canned motor pump (see Figure 1 in Section 2.2.7.2), the impeller is mounted directly to the motor rotor. The atmospheric sealing element between the motor stator and rotor is called a liner or "can." Both magnetic drive and canned motor pumps use product lubricated bearings of compatible design and materials. These bearings are usually cooled and lubricated by the pump liquid.

The following sections describe both magnetic drive and canned motor pumps.

# SECTION 2.2.7.1

## MAGNETIC DRIVE PUMPS

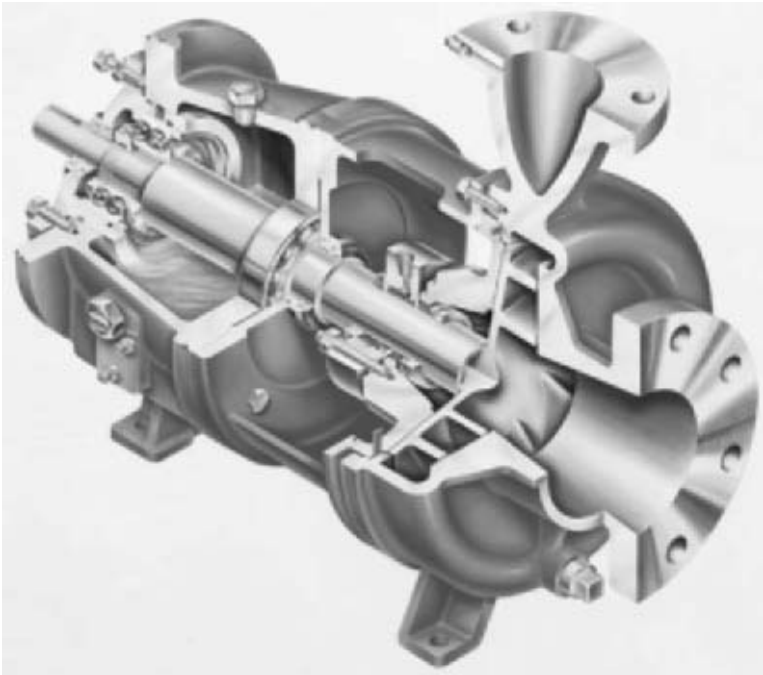
FREDERIC W. BUSE

The principle of a magnetic drive pump is the elimination of the seal or packing in an overhung pump (Figure 1) and cutting the shaft in two at the seal location (Figure 2a). On the inner or wet end half of the shaft (Figure 2b), an inner magnet assembly (a) is placed on a shaft (b) supported by product lubricated bearings (c). On the other cut portion of the shaft, an outer magnet assembly (d) is placed on the power shaft (e). Between the inner and outer magnet assemblies, a static seal (f) isolates the shell (g) or diaphragm and the pumped liquid from the atmosphere. The magnetic flux from the outer magnet assembly drives the inner magnet assembly and impeller(s). The outer assembly is mounted directly to either its own bearing assembly in a frame housing (Figure 3) or motor shaft (Figure 4). Figure 5 shows a cross-section of a magnetic drive frame mounted pump.

**Magnetics** A magnetic circuit usually consists of two sets of permanent magnets and inner and outer conducting rings (Figure 6). The conducting rings can be cast iron, ductile iron, or a 400 series stainless steel.

**Magnet Materials** The first permanent magnets, developed in the 1940s, were made of aluminum-nickel-cobalt (AlNiCo) and used in small chemical pumps. Development of rare earth magnets in the 1980s made it possible to have a small power package that could drive larger pumps. The two types of rare earth materials commonly used are neodymium iron boron (NdFeB) and samarium cobalt (SmCo). The SmCo is four times stronger than AlNiCo. NdFeB, at 70°F (21°C), is 20% stronger than SmCo. The advantage of SmCo is the maximum service temperature of 550°F (288°C), almost twice that of NdFeB, which is 300°F (149°C). Figure 7 shows the strength versus temperature characteristics of the two materials. The cost of SmCo, however, is about twice that of NdFeB.





**FIGURE 1** Pump with conventional bearing housing and mechanical seal (Flowsolve Corporation)

The magnets have a maximum temperature at which they lose all magnetism in an irreversible process; the magnets do not regain magnetism as they cool. This temperature is the Curie temperature and is shown for each magnet material in Table 1.

**TABLE 1** Operating and Curie temperatures for magnet materials

Type of Magnet Material	Operating Temperature (°F/°C)	Curie Temperature (°F/°C)
AlNiCo	660/305	800/425
NdFeB	250–300/120–137 (Depending on grade)	600/310
SmCo	500–660/260–350 (Depending on grade)	1300/700

**Conduction Ring** The amount of transmittal torque depends on the overall gap (Figure 8) between the poles of the magnets and the thickness of the conducting ring (Figure 9). If the thickness of the conducting ring is too small, it will become saturated with flux and the torque capability will be reduced.

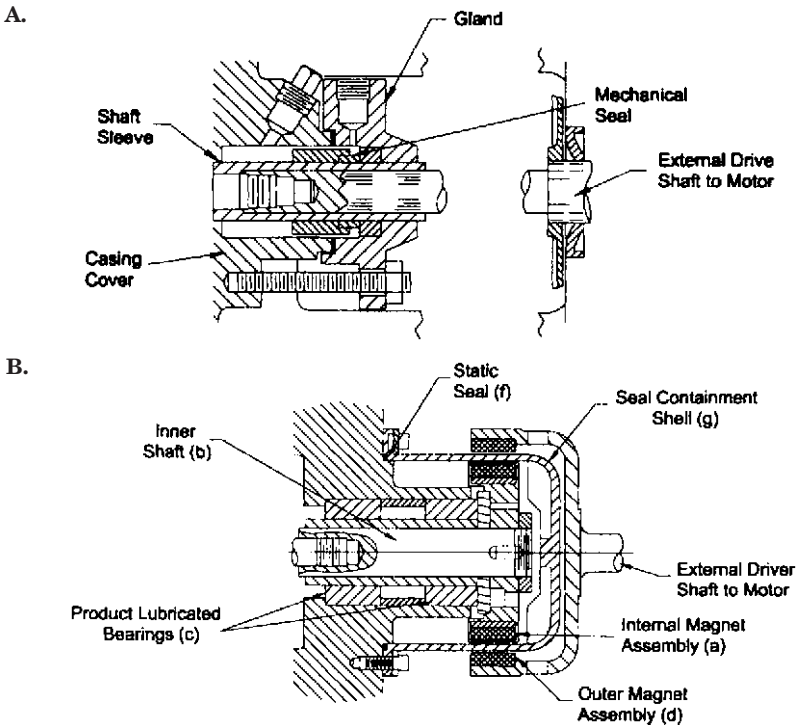


FIGURE 2 Comparison of typical mechanical seal arrangement and sealless pump drive configuration: a) arrangement for typical mechanical through casing cover; b) sealless drive configuration

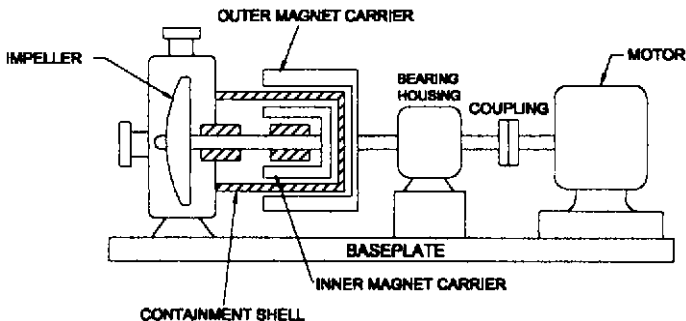


FIGURE 3 Frame-mounted magnet drive arrangement

**Gap** The “overall gap” (Figure 10) is made up of the air gap, containment shell thickness, liquid gap, and encapsulation. Gap dimensions are based on the pressure requirement for the shell, the number of magnets (single or dual), and the material of the shell (metallic or nonmetallic) in the gap.

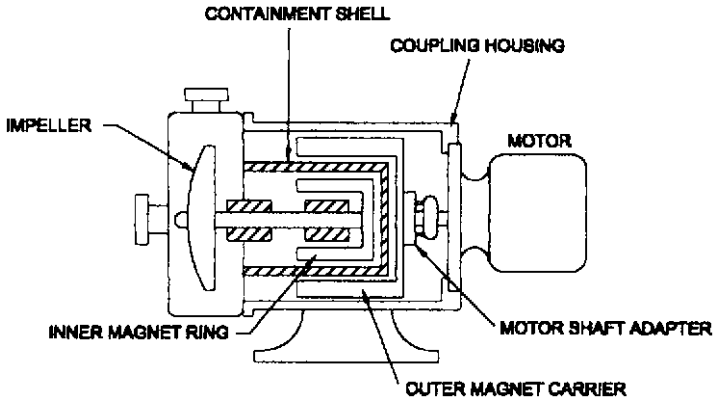


FIGURE 4 Close-coupled magnet drive arrangement

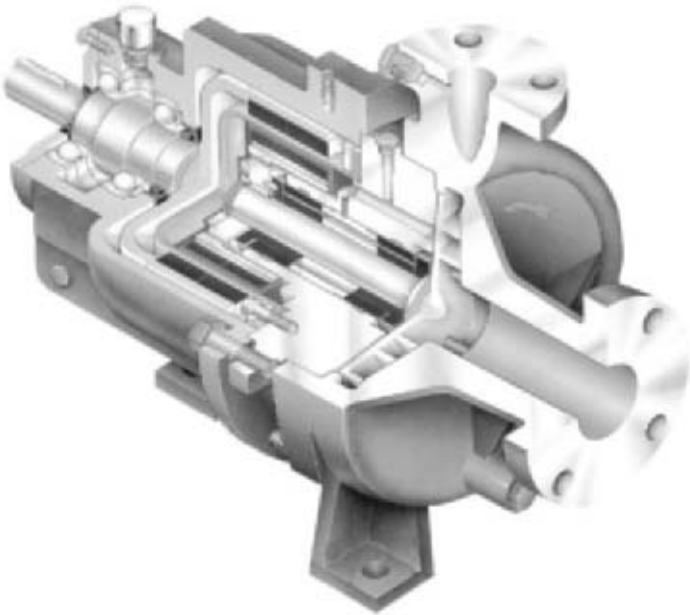


FIGURE 5 Cross-section of a frame-mounted magnet-driven pump (Flowserve Corporation)

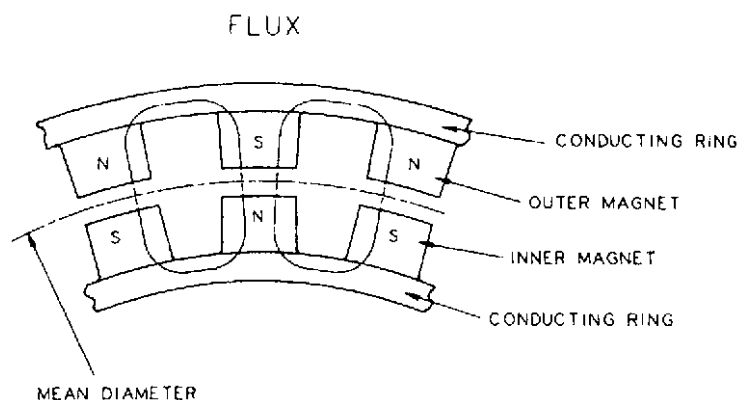


FIGURE 6 Magnetic circuit

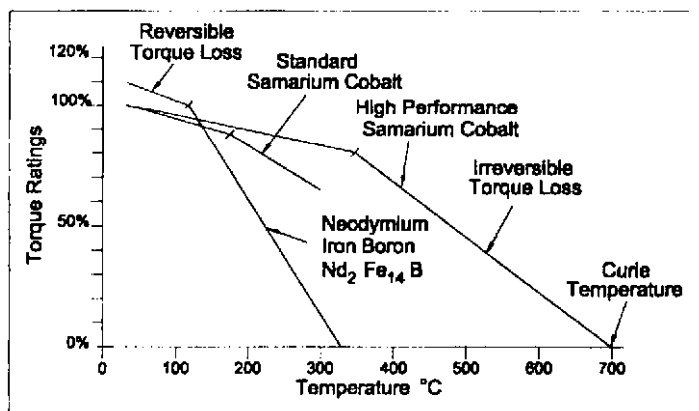


FIGURE 7 Magnet strength versus temperature

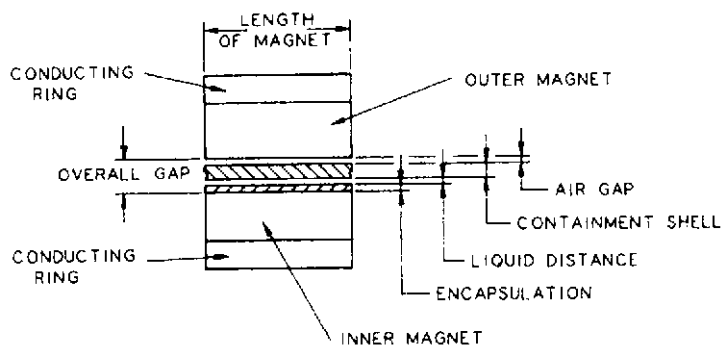


FIGURE 8 Magnet configuration

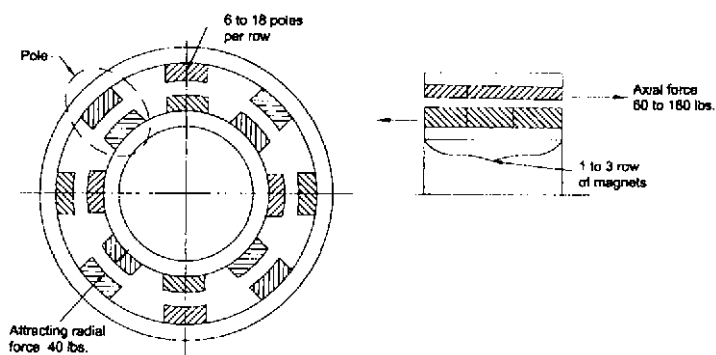


FIGURE 9 Rows of magnets

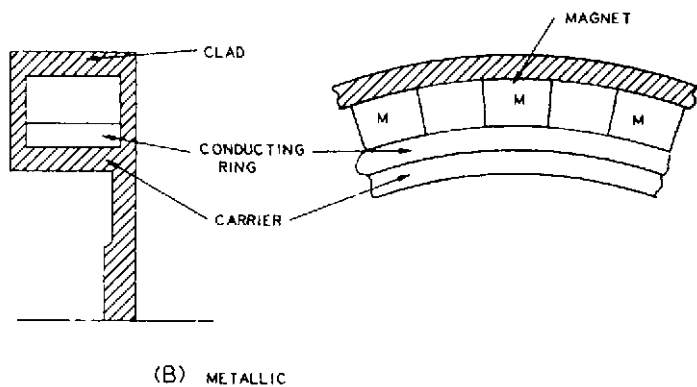
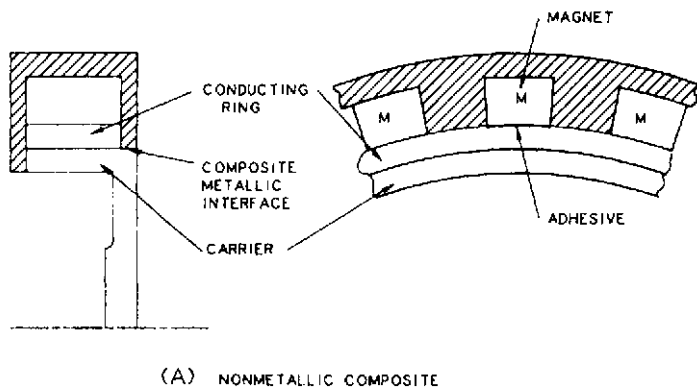


FIGURE 10A and B Encapsulation of magnets using nonmetallic composition and metallic clad

EXAMPLE Dimensions shown as in (mm)

Mean diameter (on radius dimensions)	4.6 (117)	6.0 (152.4)
Air gap minimum	.030 (0.762)	.045 (1.143)
Containment shell thickness: Hastelloy C	.040 (1.016)	.060 (1.524)
	Polymer	.120 (3.048)
Liquid gap	.035 (0.889)	.035 (0.889)
Encapsulation	.030 (0.762)	.030 (0.762)
Overall gap (basis Hastelloy C)	.135 (3.429)	.170 (4.318)
Overall gap (basis polymer)	.215 (5.461)	.260 (6.604)

In the previous example, the same overall gap was maintained for polymer and Hastelloy C shells. This allows for interchangeability of the magnetic assemblies independent of shell material.

**Transmittal Torque** The torque transmitted by the magnets depends on the following:

- Flux density of the magnets,  $B_g$
- Operating temperature of the magnets (which will change  $B_g$ )
- Length of the magnet poles,  $L$
- Number of magnets per ring,  $M$
- Mean ratios between the ID of the outer assembly magnets and OD of the inner assembly magnets,  $r$
- Overall gap between the ID and OD of the magnets in the assembly,  $g$
- A constant,  $K$ , which changes as a function of the specific design

Torque is determined from the following relationship, with appropriate units:

$$T = \frac{K \times B_g^2 \times L \times M \times r}{g}$$

For a given design type and configuration, the torque varies inversely as the square of the overall gap. Depending on costs and specific design construction, an assembly ring of magnets can have either one continuous length of magnets of a series of 1, 2, 3 or more rows of individual magnets.

## TORQUE CAPABILITY

The ultimate torque is the static “breakaway torque.” To determine this, the magnet carriers are assembled so the inner carrier is locked in position. Then a torque is applied by bar and weights or by a torque wrench to the outer carrier. The torque value at which the two carrier assemblies break loose from each other radially—or “decouple”—is called the “breakaway torque.” The designer has to account for the driver start-up acceleration time, start-up torque, and an appropriate safety factor to apply to the breakaway torque to determine the allowable applied torque.

Table 2 gives examples of the torque capability of assemblies composed of NdFeB blocks of magnet 0.75 in wide  $\times$  0.38 in high  $\times$  1.125 in long (19 mm  $\times$  9.65 mm  $\times$  28.6 mm) with a 0.180 in (4.6 mm) thick conducting ring.

**Basic Dimensioning of Magnet Blocks** The magnet blocks can be made too long or too short, resulting in handling, magnet molding, or flux density problems. The ratio of the dimensions for magnet blocks for successful designs is as follows:

**TABLE 2** Torque capability of magnet assemblies

Mean Diameter in (mm)	Magnets/Row	Overall Gap in (mm)	Breakaway Torque ft-lb (N • m)
4.3 (109)	12	0.240 (6.10)	30 (40)
6.0 (152)	18	0.260 (6.60)	60 (80)

**TABLE 3** Coefficients of thermal expansion (in/in/°F × 10<sup>-6</sup>)/(cm/cm/°C × 10<sup>-6</sup>)

Magnet material	Parallel to Axis	Perpendicular to Axis
NdFeB	5 (9)	9 (16.2)
SmCo	20 (36)	16 (28.8)

- Block width is two to three times the thickness.
- Block length is three to five times the thickness.
- Doubling the block thickness will increase the strength by approximately 20%.

For reference: 1.0 in<sup>3</sup> (16.387 cm<sup>3</sup>) of NdFeB per assembly at a mean diameter of 4.0 in (101.6 mm) with a 0.25 in (6.35 mm) overall gap produces approximately 7 ft-lb (9.5 N • m) of torque. A 3% reduction in flux density is equal to a 6% reduction in torque.

#### Characteristics of magnet material:

Density: 0.273 lb/in<sup>3</sup> (7.56 g/cm<sup>3</sup>)

Tensile: 12 × 10<sup>3</sup> lb/in<sup>2</sup> (844 kg/cm<sup>2</sup>)

Compression: 110 × 10<sup>3</sup> lb/in<sup>2</sup> (7.7 × 10<sup>3</sup> kg/cm<sup>2</sup>)

Flex stress: 36 × 10<sup>3</sup> lb/in<sup>2</sup> (2.53 × 10<sup>3</sup> kg/cm<sup>2</sup>)

Coefficients of thermal expansion are shown in Table 3.

**Radial and Axial Magnet Forces** The inner and outer carriers have to be restrained radially by bearings from contacting each other. In the example of “Torque Capability,” a single row of 18 magnets with a 6 in (152 mm) mean diameter, the radial force with magnets concentric is 40 lb (18 kgf). When the magnets are offset by .005 in (0.127 mm), the radial force is 55 lb (25 kgf) (Figure 9). When the magnets are against each other (no gap), the radial force is 80 lb (36 kgf).

In the previous example, it takes 60 lb (27 kgf) in an axial direction to separate a single row of concentric magnets and 180 lb (82 kgf) for three rows. It is strongly advisable that provisions be made for personnel to address these loads during assembly and disassembly of the carriers.

**Encapsulation of Inner Carrier Magnetics** Encapsulation can be accomplished with either metallic or polymer materials. The encapsulation of the inner magnet and conducting ring is probably the most expensive and extensive process in a magnetic drive sealless pump. After encapsulation, the carrier should be nondestructively tested to confirm 100% effectiveness.

The pros and cons of polymer encapsulation (Figure 10a) are as follows:

1. Limited to 250–300°F (120–150°C)
2. SmCo magnets are used because of the high exposure temperature when applying polymer over the magnets.

3. The overall gap is increased because of the required thickness of the polymer.
4. Magnets must be restrained mechanically on the conducting ring by adhesives or high-strength polymers around the magnets.
5. Polymers like PFA/PTFE or PEEK are more corrosive-resistant than most metals.
6. Production polymer construction is much less expensive than metallic construction.
7. Polymer tooling is expensive.

The pros and cons of metallic encapsulation (Figure 10b) are as follows:

1. Temperature rating can be 500°F (260°C).
2. Thickness of the encapsulation material over the magnets can be 0.030 in (0.76 mm).
3. Welding of the components can be conventional, electron beam, or laser. However, care must be taken with conventional welding to prevent the arc from jumping toward the magnet flux.
4. If castings are used for the inner carrier, porosity can be a problem.
5. Gassing of polymers from welding heat coming out of the seams can be a problem.
6. Adhesives are not required to keep the magnets in place at 3600 rpm with metallic encapsulation; the outer shield performs this function.

**Encapsulation of Outer Carrier Magnets** The magnets for the outer carriers do not have to be encapsulated (Figure 11). However, material like NdFeB has an infinity for water absorption that results in rusting and swelling. The magnets can then break loose and move in position relative to one another. It is highly recommended that they be encapsulated with an epoxy or metal sheathing for atmospheric protection and handling.

**Construction** The outer carrier can be a casting or fabrication. The carrier is attached to the power end shaft in the bearing housing (Figure 3) or directly to a motor shaft, which is then called *close coupled construction*. When attached to the bearing housing shaft, there is very little axial or radial load applied to the bearings. This lightly loaded condition can result in internal skidding of the rolling element bearings within their races, resulting in premature bearing failure. Therefore, it is best to preload the bearings with a spring to prevent skidding. This can be accomplished outside of the bearing by a spring-loading feature (Figure 11).

**Containment Shell** The containment shell shape and thickness depends on working pressure, material, and temperature. The shell thickness is usually uniform. To keep the

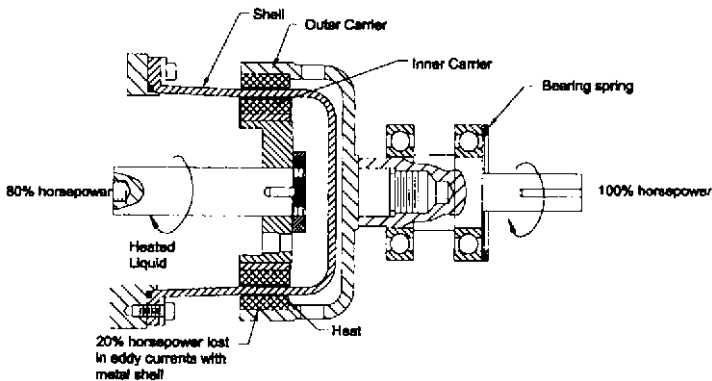
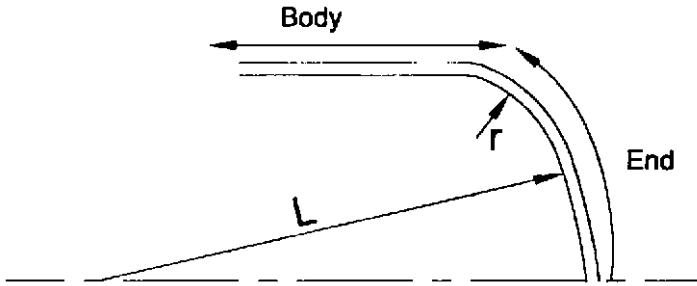


FIGURE 11 Inner and outer carrier



FIGURE 12 Shell ratio  $L/r$  for pressure**TABLE 4** Pressure capabilities of shells with various end shapes for the same thickness and material

Shape	$L/r$	Allowable pressure—lb/in <sup>2</sup> (kPa)	Ratio of allowable pressure to that for a flat plate
Flat	533	9 (62)	1.0
Flat	267	23 (158)	2.55
Elliptical	28	113 (779)	12.6
Elliptical	8	209 (1440)	23.2
Spherical	1	815 (5620)	90.5

length of the shell to a minimum, a square-ended shell can be used. However, unless the end of the shell is made extra thick, it would have a relatively low pressure capability. Therefore, an end shape which is elliptical or spherical is used to obtain higher pressure capability (Figure 12).

Examples of how allowable shell pressure varies with the shape of the end plate are shown in Table 4.

The classes of materials used for containment shells (Figure 11) include metals, polymers, and ceramics. The characteristics of containment shells of various materials are shown in Table 5. The main advantage of polymer or ceramic shells is that there are no eddy current losses. Therefore, cooling of the magnets is not required.

**Eddy Currents** Metallic or metallic-lined shells will produce eddy currents. Depending on the thickness of the shell, the eddy current losses ( $P_L$ ) can amount to as much as 20% of the total power.

$$P_L = \frac{K \times T \times L \times N^2 B_g^2 D^3 M}{R}$$

where  $K$  = a constant, depending on the design

$T$  = thickness of the shell

$L$  = length of magnets (times the core of magnets)

$N$  = speed, rpm

$B_g$  = flux density of the magnets

$D$  = mean diameter

$M$  = number of sets of magnets

$R$  = electrical resistivity, microhms per cm<sup>3</sup> (electrical resistivity for various shell materials is given in Table 6)

**TABLE 5** Characteristics of containment shells of various materials

Material	Metal	Reinforced polymer	Ceramic	Metal with PTFE
Construction	Welded or hydroformed	Injection molded	Set and fired	Spray coated
Temperature limit—°F (°C)	-300 to +750 (-150 to +400)	-40 to +250 (-4 to +120)	32 to 2000+ (0 to 1100+)	32 to 350 (0 to 175)
Thickness—in (mm)	0.030–0.040 (0.76–1.0)	0.170 (4.3)	0.250–0.380 (6.35–9.6)	0.050 (1.27)
Heat conductivity*	Hastelloy C = 71 AISI 316 = 7.5	3	6	Higher than metal alone
Creep	None	None	None	Some
Thermal shock	1000+ (537+)	375 (190)	500 (260)	—
Eddy currents	316 is twice Hastelloy C	None	None	Same as metal

\*Approximate thermal conductivity in Btu/hr/ft<sup>2</sup>/°F. Multiply by 0.488 to get calories/hr/cm<sup>2</sup>/°C

**TABLE 6** Electrical resistivity of various shell materials

Shell Material	Electrical Resistivity ( <i>R</i> ), microhms per cm <sup>3</sup>
Hastelloy C	130
AISI 316L	74
Inconel 625	129
Nimonic 90	115
Titanium	53
K-Monel	58
Alloy 20	75

**TABLE 7** Effect of material selection on heat build-up

Material of shell	Thickness—in (mm)	Time—minutes	kW	°F (°C)	°F/min (°C/min)
AISI 316	0.43 (10.9)	Start	0.40	80 (27)	—
AISI 316	0.43 (10.9)	5.0	0.30	500 (260)	100 (38)
Hastelloy C	0.43 (10.9)	0.5	0.24	170 (77)	340 (171)
Hastelloy C	0.43 (10.9)	5.0	0.21	370 (188)	74 (23)

The effect of material selection on heat build-up is shown in Table 7. The tabulation shows the temperature rise of the air space inside a shell with only the outer carrier spinning around a metallic shell (no inner carrier in place) at 3550 rpm. The carrier has 12 magnets, 1.25 in (3.175 cm) long, with a mean diameter of 4.25 in (11.43 cm).

This illustrates the difference between AISI 316 and Hastelloy C shells at 3550 rpm. At 1750 rpm, the power loss for AISI 316 would be one-fourth that at 3550 rpm, which may not result in excess power consumption.

There are also axially laminated metal shells available that substantially reduce eddy current ( $I^2R$ ) losses. These laminations work on the principle that when a shell length is

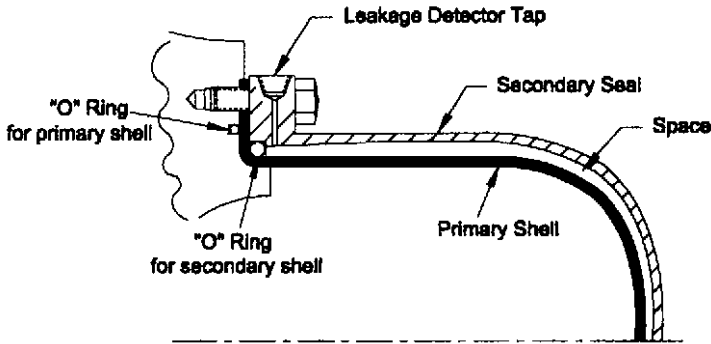


FIGURE 13 Dual containment

cut in half, the eddy current losses are reduced to one-fourth their original value. If the one-half shell length is cut in half again, the resulting pieces have eddy current losses one-sixteenth that of the original shell. A shell design made of segments sealed together to make a full-length shell will thus reduce total eddy current losses.

**Dual Containment** As a precaution against leakage due to a breach in the primary containment shell, a dual or double-containment arrangement can be used. This double layering of shells (Figure 13) usually consists of a combination of a nonmetallic and metallic shell. The pressure rating of the secondary shell is equal to that of the primary shell. It is designed to operate at least 48 to 120 hours after a breach in the primary shell occurs. A pressure monitor is inserted in the flange of the secondary shell to detect pressure buildup from primary shell leakage.

**Bearings** The internal shaft system of the pump is supported by one or more bearings. Some designs use a rotating shaft; others use a mandrel on which the bearings rotate. The bearing, which consists of a journal and bushing, is made of various materials, depending on the loads and pumpage (used for product lubrication). The bearing loads are from the weight of the components and hydraulic forces from the impeller and inner carrier. The impeller forces are both radial and axial.

Most magnetic drive sealless pumps are single-stage volute pumps that have the same radial bearing loads as comparable conventionally sealed pumps. The main difference with the sealless pump is that there is almost no overhang from the impeller to the first bearing. The load on the bearing, therefore, is almost equal to that of the impeller. In a conventionally sealed pump, the load on the radial bearing is almost twice that of the impeller. This can be seen by comparing Figures 1 and 5.

The axial load will depend on whether the impeller is enclosed or semi-open (Figure 14). Enclosed impellers usually have horizontal front rings and may also have a back ring or pump out vanes (POV). Semi-open impellers have no rings, but they usually employ scallops in the shroud to reduce the effective pressure area (Figure 15). Axial thrust force is further reduced by employing pump-out vanes (POV) or pump-out slots (POS) on the back shroud of the impeller to reduce the amount of pressure on the impeller back shroud.

The enclosed impeller can have less radial and axial load than a semi-open impeller. This is usually accomplished by employing back rings (14b). To ensure positive pumping in the lubrication flow path in magnetic drive pumps, POV-POS on an enclosed or semi-open impeller are recommended.

Liquids pumped in chemical or petroleum plants may have low viscosity, low specific gravity, or low specific heat. These characteristics can result in boundary lubrication rather than hydrodynamic lubrication of the product lubricated bearings. Therefore, bearings are selected using PV (pressure-velocity) values. Some limiting PV values for various bearing material combinations are shown in the following section on bearing materials.

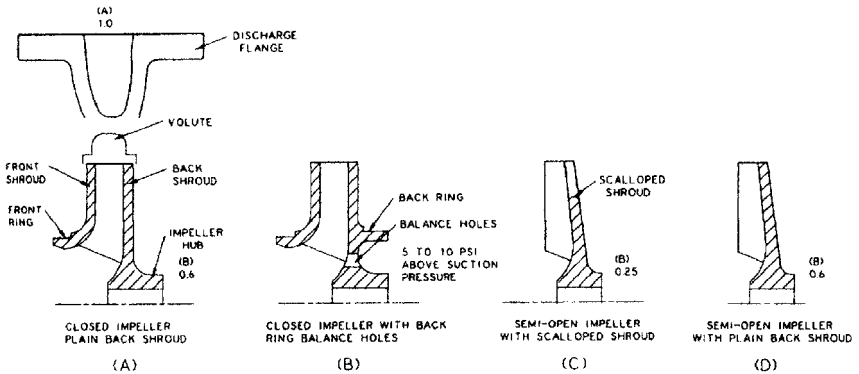


FIGURE 14A through D Various enclosed and semi-open impeller configurations

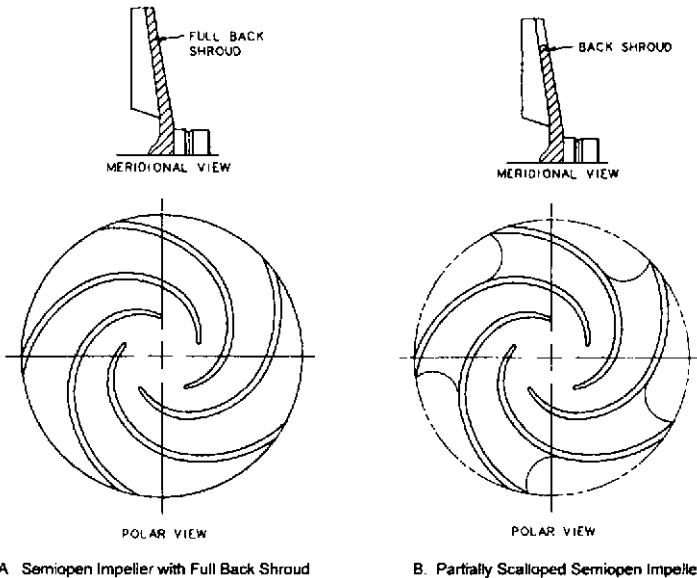


FIGURE 15A and B Semi-open impellers with a full back shroud and with a partially scalloped back shroud

**Bearing Materials** Table 8 shows PV values for various bearing journal and thrust face materials. When loads exceed a PV value of 150,000, the bearing should have an alignment compensator built in to correct for inaccuracies in perpendicularity, concentricity, and parallelism of parts.

When designing the bearing, thermal expansion and heat conductivity properties must be considered. Some designs have a temperature range of  $-300^{\circ}\text{F}$  to  $+750^{\circ}\text{F}$  ( $-150$  to  $+400^{\circ}\text{C}$ ). Table 9 lists bearing material characteristics to facilitate selection of the proper material for the intended application.

**Particles** For the softer bearing materials, the maximum particle size should be no more than 10% of the diametral clearance for a bearing with no grooves and no more than 20%

**TABLE 8** PV values for various bearing journal and thrust face materials

Bushing Materials	Journal/Thrust Face PV ( $\times 10^3$ )*
Carbon Graphite vs. AISI 316	150
Carbon Graphite vs. Chrome Oxide Hardened Coating	250
Silicon Carbide vs. Hardened Coating	250
Silicon Carbide vs. Carbon Graphite	300
Silicon Carbide vs. Silicon Carbide	500
PEEK—Carbon-filled vs. Hardened Coating	150
Polyimide-carbon filled vs. Hard Coating	150

$P$  = Net load/projected area (minus area for slots), psi

$V$  = Velocity at the shaft diameter or mean diameter of the thrust face in ft/min

\*Note: Multiplying the PV values in the table by 2.1 will give values equal to  $P$  in kPa and  $V$  in m/min.

**TABLE 9** Bearing material characteristics

Material	Thermal Expansion (note 1)	Heat Conductivity (note 2)	Hardness (note 3)
AISI 316	9.6	7.5	160 BHN
Hastelloy C	6.7	71	170 BHN
Carbon graphite	2.6	5	95 Vickers
Silicon carbide— self-sintered	2.2	85	2400 Vickers
Silicon carbide with carbon	2.0	75	2400 Vickers
PEEK—Carbon-filled	8.0	6	
Polyimide—Carbon-filled	5.0		100–150 BHN
Aluminum oxide			1800 Vickers
Chrome oxide			1800 Vickers

Note 1: in/in/ $^{\circ}$ F  $\times 10^{-6}$  (multiplied by 1.411 to get cm/cm/ $^{\circ}$ C)

Note 2: BTU/hr/ft $^2$ / $^{\circ}$ F (multiply by 0.488 to get calories/hr/cm $^2$ / $^{\circ}$ C)

Note 3:  $R_c \times 25 =$  Vickers; BHN  $\times 10 = R_c$

for a bearing with grooves. Polymers and graphites are much softer than silicon carbides or hard coatings, and they are not recommended for liquids with hard particles. Silicon carbide versus silicon carbide will grind up most particles. For particle concentrations of 50 parts per million (ppm) or less, particle hardness is generally not a factor in bearing performance.

Strainers of 100 mesh are recommended to reduce the amount and size of particles going through the flow path. These strainers are installed for internal or external injection. Remember: Particles that will pass through a 100 mesh screen may be as large as 0.006 in (0.15 mm), whereas nominal diametral bearing clearances of 0.002 in (0.05 mm) are common.

Note also that the bearing material combination of silicon carbide against silicon carbide or against carbon is electrically conductive.

**Running Dry** Most sealless pump failures occur because the pump system is not monitored and the pump is allowed to run dry. When this happens, the bearings will run dry. When the bearings run dry, hard, brittle bearing materials such as self-sintered silicon

carbide will fail within minutes. Graphite silicon carbide may run dry for as many as 10 to 20 minutes with no damage. The polymers, which are poor heat conductors, expand inwardly and seize against the mating surface. The graphites will also move inwardly, but they tend to wear rather than seize, which results in excessive clearances when the pump is stopped and cooled. One optional design uses Teflon strips that expand inwardly when the unit runs dry so the shaft runs on the Teflon rather than on the silicon carbide, thus helping to avoid bearing failure.

Another option is to employ an external circulating tank, with no external running parts, that will provide the bearings with external lubricating liquid should dry operation occur. This type of external tank system has allowed pumps to operate for two hours or more without incurring damage to the bearings.

**Flow Path** The amount and direction of flow for cooling of the magnets and lubrication of the bearings is critical to the operation of a sealless pump (Figure 16). It is preferable for the liquid to lubricate the bearings before being heated by the magnets. This reduces the possibility of vaporization of the liquid occurring at the thrust-bearing faces. The amount of liquid circulated through the system is usually between 1 and 8 gpm (4 and 30 l/min). It is usually channeled to the front and back bearings, the thrust bearing face, across the magnets, and to the impeller hub. Some manufacturers have computer programs that calculate the flow, pressure, and temperature of the cooling/lubricating flow at various critical locations along the flow path. These programs can also account for the effects of the liquid specific gravity, specific heat, and viscosity. The local pressure and temperature is used to determine the vapor pressure at that point to ensure that the liquid is not flashing. The programs can also calculate axial thrust and determine if the lubrication at the thrust bearing face is hydrodynamic or boundary. This is done at various flow rates, impeller diameters, and pump speeds.

The temperature rise of the liquid as it travels through the cooling-lubricating flow path depends to a great extent on the liquid's characteristics, such as specific gravity, specific heat, vapor pressure, and viscosity. With a nonmetallic shell on ambient water service, a typical temperature rise might be 1 to 2°F (0.5 to 1°C). For a metallic shell, with its much higher eddy current losses, the temperature rise could be as much as 8 to 12°F (4 to 7°C).

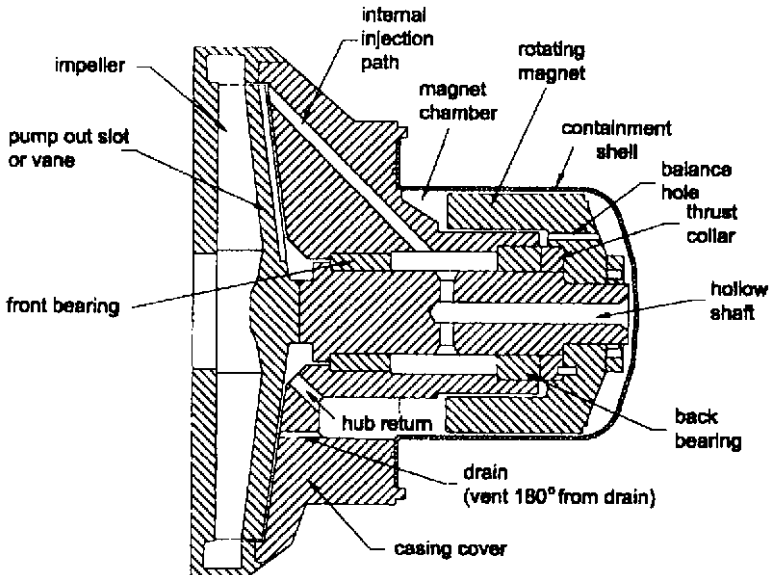


FIGURE 16 Magnetic sealless pump components for the internal flow system

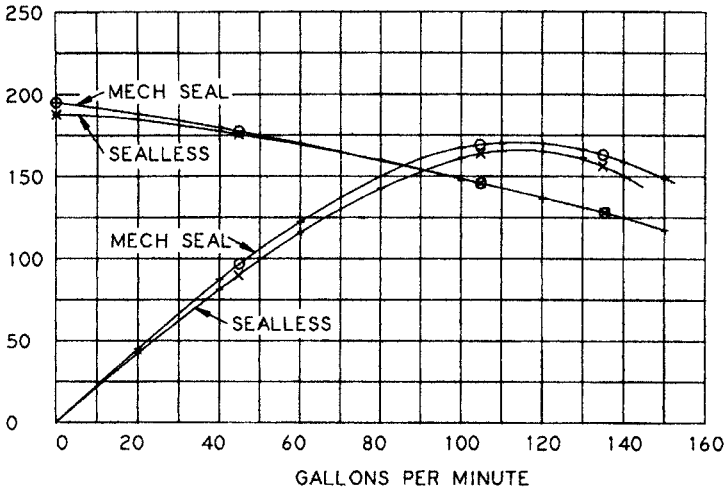


FIGURE 17 Typical performance for a  $1.5 \times 1.0 \times 6$  pump at 3550 rpm, comparing characteristics for sealless versus mechanical seal construction

**Performance** The head capacity curve of a typical two-pole speed sealless pump matches that of a conventionally sealed pump; however, the overall efficiency is lower. With a nonmetallic shell, the efficiency may be only about two points less at the best efficiency point flow rate, but as much as six points less at one-half the best efficiency point flow rate. When a metallic shell is used, the efficiency at best efficiency point flow rate may be as much as 8 to 12 points lower than a comparable pump with a mechanical seal (Figure 17).

#### APPLICATION ADVANTAGES OF SEALLESS PUMPS:

- No leakage to the environment
- No loss of valuable liquids
- Lower noise levels
- High suction pressure does not affect the axial thrust
- Can handle liquids from 0 to 4 toxicity rating
- Because of no leakage, there is much less chance of a fire
- Easier to obtain construction permits and permits for continued operation
- Less external piping required

#### APPLICATIONS THAT SHOULD BE REVIEWED BEFORE SEALLESS PUMPS ARE APPLIED:

- Dirty liquids
- High temperature
- Liquids that solidify
- Viscous liquids above 200 centipoise
- Oversize drivers that can cause decoupling during acceleration
- Cavitation of liquid in the impeller eye that can result in excess thrust
- Excessive entrained gas

**REFERENCES AND FURTHER READING**

---

1. American National Standard for Sealless Centrifugal Pumps, ANSI/HI 5.1–5.6-2000, Hydraulic Institute, Parsippany, NJ [www.pumps.org](http://www.pumps.org).
2. Hydraulic Institute ANSI/HI 2000 Edition Pumps Standards, Hydraulic Institute, Parsippany, NJ [www.pumps.org](http://www.pumps.org).
3. Sealless Pumps for Petroleum, Heavy Duty Chemical, and Gas Industry Services, API Standard 685, 2000, The American Petroleum Institute, 1220 L Street, Northwest, Washington, D.C. [www.api.org](http://www.api.org).
4. Specification for Sealless Horizontal End Suction Centrifugal Pumps for Chemical Process, ANSI/ASME B73.3M-1997, The American Society of Mechanical Engineers, 345 East 7th Street, New York, NY [www.ASME.org](http://www.ASME.org).
5. Eierman, R. "A User's View of Sealless Pumps—Their Economics, Reliability, and the Environment." *Proceedings of the Seventh International Pump Users Symposium*. Texas A&M University, College Station, TX, March 1990, pp. 127–133.
6. Hernandez, T. "A User's Engineering Review of Sealless Pump Design Limitations and Features." *Proceedings of the Eighth International Pump Users Symposium*. Texas A&M University, College Station, TX, March 1991, pp. 129–145.
7. Littlefield, D. "Sealless Centrifugal Pumps." *Proceedings of the Eleventh International Pump Users Symposium*. Texas A&M University, College Station, TX, March 1994, pp. 115–119.
8. Guinzburg, A., and Buse, F. "Computer Simulation of the Flowpath in Magnetic Sealless Pumps." *Proceedings of the Fifteenth International Pump Users Symposium*. Texas A&M University, College Station, TX, March 1998, pp. 1–9.



# SECTION 2.2.7.2

## CANNED MOTOR PUMPS

STEPHEN A. JASKIEWICZ

A canned motor pump (CMP) is a combination of a centrifugal pump and a squirrel cage induction motor built together into a single hermetically sealed unit (see Figure 1). The pump impeller (A) is normally of the closed type and is mounted on one end of the rotor shaft that extends from the motor section into the pump casing. The rotor (B) is submerged in the fluid being pumped and is therefore “canned” to isolate the motor parts from contact with the fluid. The stator (C) is also “canned” to isolate it from the fluid being pumped. Bearings (D) are submerged in system fluid and are, therefore, continually lubricated.

The canned motor pump has only one moving part, a combined rotor-impeller assembly that is driven by the magnetic field of an induction motor. A portion of the pumped fluid is allowed to recirculate through the rotor cavity to cool the motor and lubricate the bearings. A self-cleaning filter can be provided, on pumps having external circulation, to filter the recirculation fluid before it enters the bearing section of the motor. The stator windings and rotor armature are protected from contact with the recirculating fluid by a corrosion resistant, non-magnetic, alloy liner (E) that completely seals or “cans” the stator winding.

Modifications to the recirculation flow system are available to allow canned motor pumps to be used in any application including fluids up to 1000°F (538°C), volatile liquids, and liquids with solids.

### **BASIC DESIGN**

---

**Stator Assembly** The stator assembly of canned motor pumps (see Figure 2) consists of a set of one or three-phase windings (A). Stator laminations (B) are constructed of low-silicon grade steel. Laminations and windings are mounted inside the cylindrical stator band (C). End bells (D and E), welded to the stator band, close off the ends of the stator

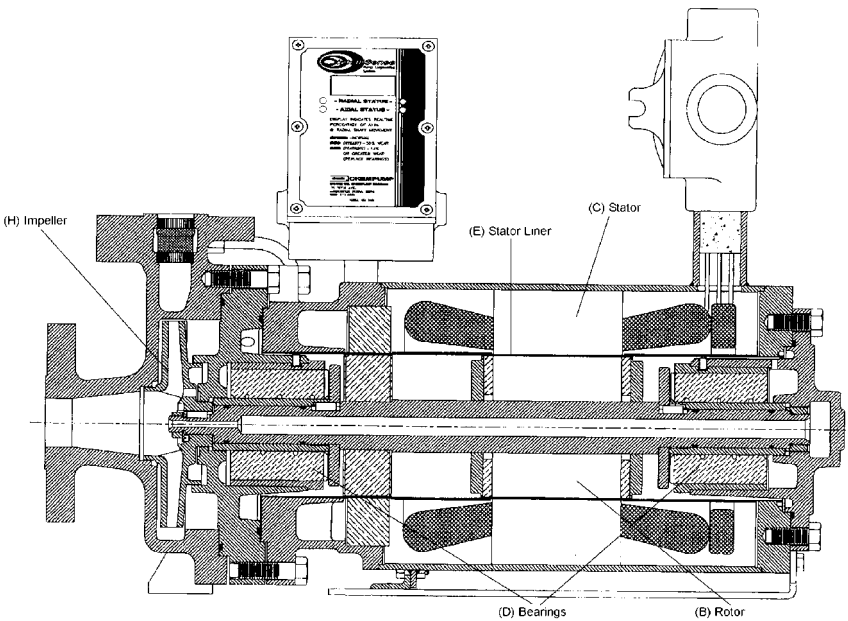


FIGURE 1 Typical canned motor pump

assembly. The stator liner (F) is supported on the outside diameter by the steel lamination of the motor. Back-up sleeves (G) are provided to strengthen those areas of the stator liner not supported by the stator laminations. The stator liner is, in effect, a cylindrical “can” placed in the stator bore and welded to the rear end bell and front end bell shroud to hermetically seal off the windings from contact with the liquid being pumped. Terminal leads (H) from the windings are brought out through a pressure tight lead connector (I) mounted on the stator band and terminated in a standard connection box.

Motors are either designed and manufactured specifically for use in canned motor pumps or components of conventional motor are modified. A variety of motor insulation types is available ranging from temperature limits of 266°F (130°C) to above 482°F (250°C).

Because the pump and motor are one unit, the complete assembly must be tested and approved for explosion-proof applications. Explosion-proof pumps are rated as either Class 1, Group D, Division 1 or Class 1, Group C & D, Division 1 locations. It is not uncommon to operate canned motor pumps with variable speed drive controllers.

**Rotor Assembly** The rotor assembly is a squirrel cage induction rotor constructed and machined for use in canned motor pumps (see Figure 3). It consists of a machined corrosion resistant shaft (A), laminated core (B) with copper or aluminum bars and end rings, corrosion resistant end covers (C), and a corrosion resistant can (D). Various methods are used to attach the impeller to the motor shaft (E).

The rotor end covers are welded to the shaft and to the rotor can that surrounds the outside of the rotor, thus hermetically sealing off the rotor core from contact with the liquid being pumped.

Some manufacturers offer replaceable shaft sleeves (F) and axial thrust surfaces (G) for longer service life and ease of maintenance.

**Bearings** Only two bearings are required for canned motor pumps. These bearings are normally cooled and lubricated by the pumped fluid; therefore, they must be compatible

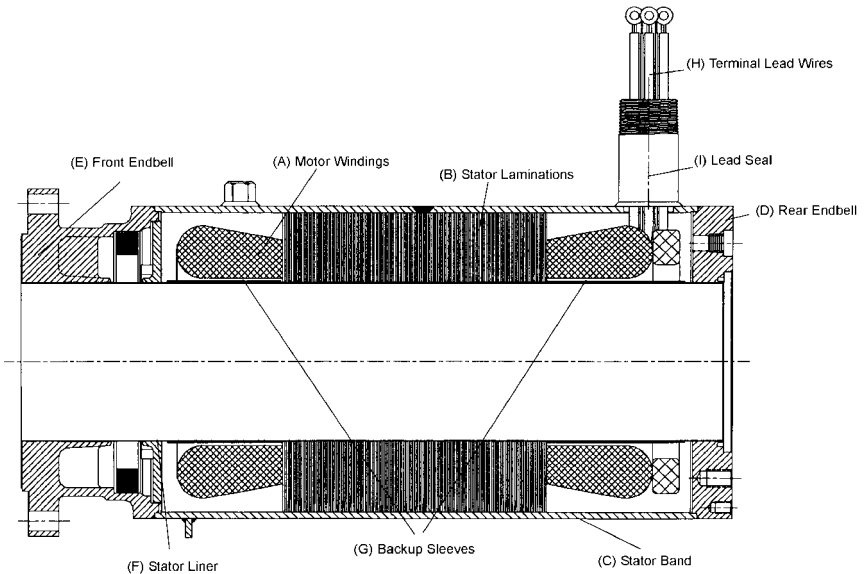


FIGURE 2 Stator assembly

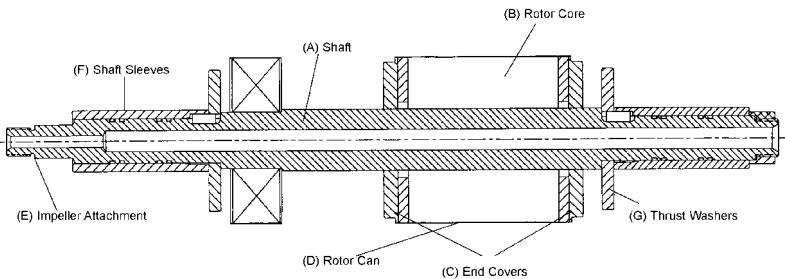


FIGURE 3 Rotor assembly

with the process fluid. A multitude of materials is available such as various grades of carbon graphite, silicon carbide, aluminum oxide, and many polymers. Bearing selection is dependent on the compatibility with the process fluid, amount of solids present, and pumping temperature.

A hydrodynamic bearing is the most common type of bearing used. The bearings can be either stationary or rotating with the rotor assembly. In either case, the fluid passes between the bearing and shaft journal, resulting on the rotating assembly running on a thin film of liquid, not the journal and bearing. Most bearings have helical grooves in the inside diameter to increase the flow of process fluid through the journal area, thereby decreasing the temperature of the bearings.

**Internal Clearances** The determination of the overall gap between the stator windings and the rotor armature is paramount in the design and operation of the pump. The wider the distance between the iron of the motor winding and the rotor armature, the less efficient the motor becomes. The material of construction of the stator liner and rotor sleeve

also effects motor efficiency. Stainless steels and Hastelloy are the most common materials used for stator liners and rotor sleeves. Although stainless steel is less expensive, Hastelloy C has higher corrosion resistance, is a stronger material, and offers lower electrical losses. Motor efficiency in canned motor pumps is not only important for energy cost considerations, but also for the amount of heat input to the recirculation fluid.

The stator liner (a wetted, pressure boundary component) ranges in thickness between 0.010 to 0.040 in (0.254 to 1.016 mm). For high-pressure applications, the liner remains at the same thickness, but the outside diameter is supported by the motor laminations and by back up sleeves located on both sides of the motor. Canned motor pumps have been designed to withstand working pressures up to 5,000 lb/in<sup>2</sup> (345 bar) with 0.015 in (0.381 mm) stator liners and heavy walled back-up sleeves.

The rotor armature (a wetted component) is also protected from the process fluid by a sleeve and two end covers. The thickness of the rotor sleeve ranges from 0.010 to 0.25 in (0.254 to 6.35 mm). The radial running clearance between the rotating motor armature and the stationary stator liner is usually about 0.020 in (0.508 mm). The total diametral clearance can range from 0.040 to 0.075 in (1.016 to 1.905 mm), or higher, depending on the manufacturer's design.

**Secondary Containment** Canned motor pumps offer a level of safety and process fluid containment unavailable with any other type of pump. Positive, secondary containment of the process fluid is a built-in feature with canned motor pumps when the motor lead wires are housed in a pressure retaining lead seal. In case of a failure of the primary containment shell (stator liner), the outer stator band becomes a secondary containment vessel, preventing the process fluid from entering the environment.

The outer stator band is far removed from the rotation element, making it impossible for the rotating element to make contact. When secondary containment is required, the stator band assembly should be designed and tested to the same pressure and temperature rating as the pump.

## **PRINCIPLE OF OPERATION**

---

**Flow Path** Most canned pumps, when pumping relatively clean fluids, will channel a small portion of the process fluid through the motor section. This fluid cools and lubricates the bearings and removes heat generated by the induction motor. The circulation path can be either external or internal to the pump. With external circulation (see Figure 4), the recirculation fluid is piped outside of the pump, through a filter, and then into the motor section of the unit. The filter assembly (see Figure 5) is self-cleaning and located in the discharge flange of the pump. Pumps having internal circulation have the recirculation contained within the pump. Filtering the recirculation liquid is not available with internal circulation.

In either external or internal circulation, the flow path is from the high pressure area of the pump (pump discharge or pump chamber at the tip of the impeller) returning to the low pressure area (near the hub or eye of the impeller). The amount of liquid recirculated through the motor section ranges from 2 to 16 gpm (7.5 to 60 l/m).

Many recirculation flow path modifications are available to allow a canned motor pump to pump any type of fluid. When pumping volatile fluids, the motor section can be pressurized by an auxiliary impeller located on the rotor. The recirculation fluid, which normally returns to the eye of the impeller, is channeled to the pressurized section of the liquid end, increasing the pressure in the motor section. This design allows a volatile fluid to remain liquid even with a temperature increase caused by motor heat (see Figure 6). Another method to handle fluids near their boiling point is to reverse the recirculation flow path. Instead of returning the heated liquid back to the eye of the impeller, the recirculation liquid is removed from the pump and returned to the suction vessel.

High temperature and slurry applications can be handled by canned motor pumps by isolating the bearings from the pumped fluid. The recirculating fluid in the motor section

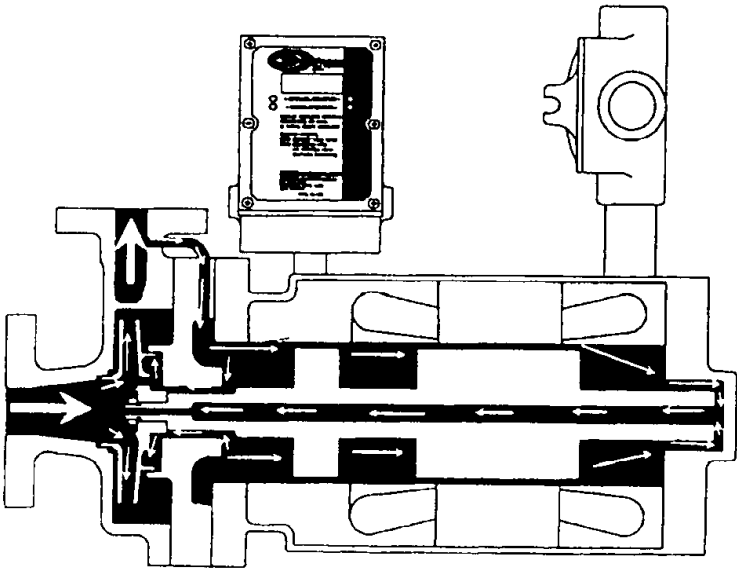


FIGURE 4 External circulation flow path

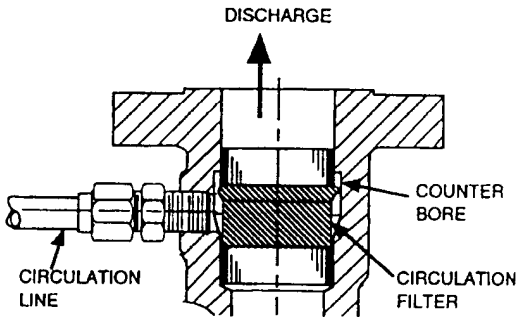


FIGURE 5 Self-cleaning filter assembly

is used for lubrication of the bearings and cooling of the motor. This fluid remains in the motor section and is circulated through the rotor cavity by an auxiliary impeller, which is an integral part of the rotor assembly. The fluid in the motor section is forced across the rotor and through the bearings, after which it flows through a heat exchanger. The heat exchanger is cooled by water or a suitable heat transfer fluid (see Figure 7). The motor section can be backflushed with a clean, cooled liquid when handling slurry.

In Hydraulic Institute Standard ANSI/HI 5-1-5.6, Figure 5.9 provides an excellent description of various recirculation flow plans for sealless pumps.

**Thrust Balance** Because most canned motor pumps use hydrodynamic bearings, the rotating assembly is allowed to float axially. This movement is known as “end play” and is defined as the movement of the rotor, in the axial direction, between the forward and

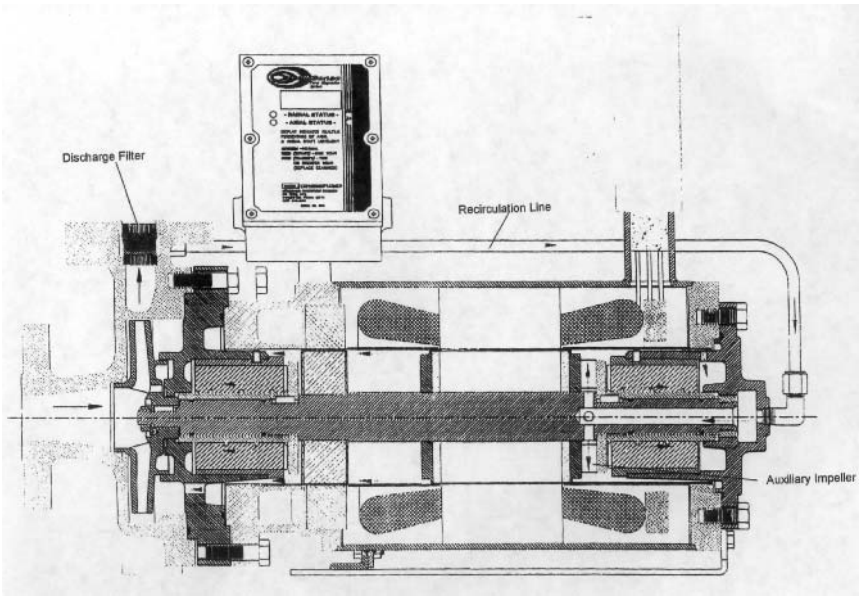


FIGURE 6 Pressurized circulation

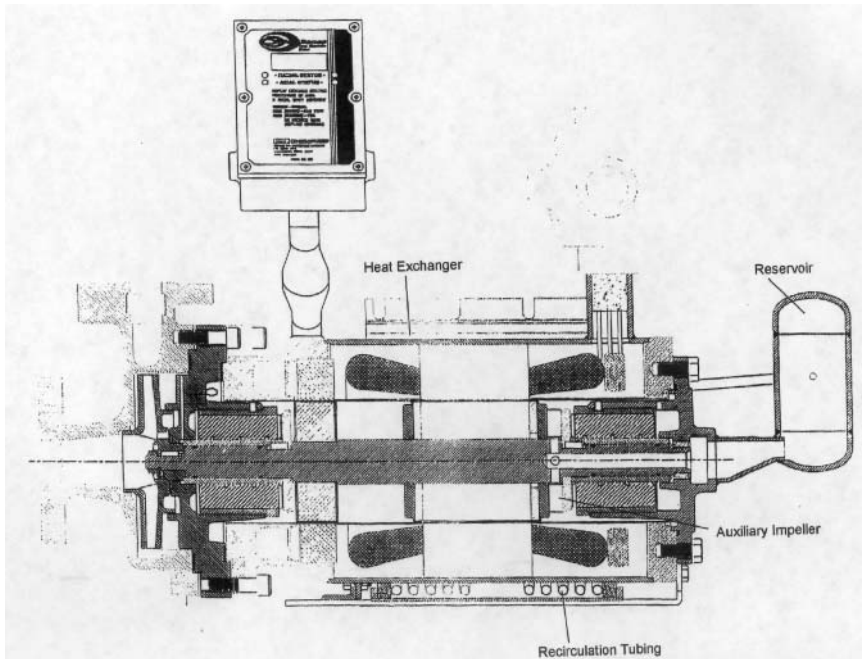


FIGURE 7 Isolated motor section

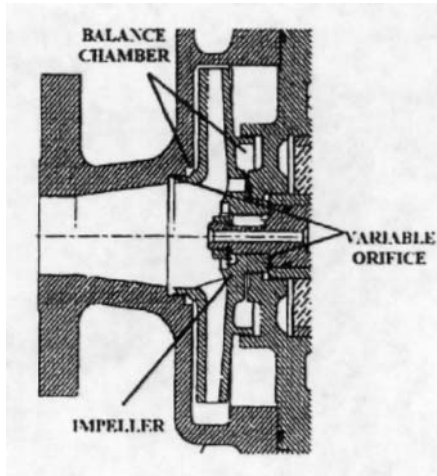


FIGURE 8 Automatic hydraulic thrust balance

rear contact points (normally the thrust bearings). Many canned motor pumps incorporate a principle of hydraulic thrust balance to position the rotation assembly between the forward and rear mechanical contact points. Based on hydraulic principles, automatic thrust balance is accomplished by the pressure of the pumped fluid. Pressure chambers are designed either within the pump chamber using the movement of the impeller or rear of the pump controlling the rate of return of the process fluid.

Figure 8 illustrates hydraulic thrust balance within the pump casing. Balance chambers are located on the front and rear of the impeller. When a change in axial load changes the position of the impeller, either forward or rear, there is an equalizing change of hydraulic pressure in the balance chambers, which immediately returns the rotation assembly into a balance position.

**Pressure-Temperature Profile** The single most important consideration in the application and successful operation of canned motor pumps is bearing environment control. The process fluid cools and lubricates the bearings and removes the heat generated by the motor. The bearings must remain in a liquid state to provide adequate bearing lubrication.

A number of variables must be considered when considering the state of the recirculation fluid. These variables include vapor pressure, specific heat, specific gravity, viscosity, pump efficiency, motor efficiency, motor load, recirculation flow rate, and the recirculation flow system. A vapor pressure curve versus temperature of the process fluid is also necessary. Figure 9 illustrates heat balance equations necessary to determine the temperature rise of the fluid within the motor section. Figures 10a, b, and c show pressure and temperature profiles for a specific fluid based on the heat balance equations within a canned motor pump modified for pressurized circulation. If the flow rate varies, a new profile should be calculated for each design condition.

A pressure-temperature profile should be calculated for any application where there is doubt concerning the condition of the recirculation fluid.

**Installation** The installation of a canned motor pump can be much less costly than a conventionally sealed unit because canned motor pumps do not require special base-plates or mounting pads. In fact, many canned motor pumps are stilt-mounted or bolted directly into the system piping. There is only one shaft in a canned motor pump; therefore, alignment of the pump to the driver is not necessary and pump orientation is not critical. The unit can be mounted either horizontally or vertically, with the pump casing



	pump model NC-A60-10-N5	Fluid- 95-5 TCS		
	Bypass, GP standard	0.000	Reverse	Pressurise
desired flow, gpm	300.000		300.000	300.000
head, ft	240.000		240.000	240.000
temperature in, F	150		150	150
specific heat, btu/lb F	0.260		0.260	0.260
specific gravity	1.240		1.240	1.240
hydraulic power, hp	22.545		22.545	22.545
Total pump flow, gpm	300.000		300.000	300.000
pump efficiency - Note	58.0		58.0	58.0
motor output HP	38.871		38.871	38.871
Delivered Pump Head, Ft	240.000		240.000	240.000
motor efficiency, Note	80.0		80.0	80.0
motor input KW	36.233		36.233	36.233
Overall efficiency	46.4		46.4	46.4
Impeller diameter, in.	8.500		8.500	8.500
Motor circulation flow	6.600		6.000	6.000
Process Wire-Water Eff.	46.4		46.4	46.4
Total Circ rate, GPM, N	9.000		6.000	6.000
Psuct at NPSH= 61ft.	77.269		77.269	77.269
Temperature rise:				
Standard circ (pump)	1.37			1.37
temp. pump exit	151.4			151.4
circ flow (motor)	23.2			25.6
total temperature rise	24.6			26.9
max temp. circ. flow	174.6			176.9
Est. P vap, psia	63.102			
Reverse circ (pump)			0.82	
temp. pump exit			150.8	
circ flow (motor)			25.6	
Total temperature rise			26.4	
max. temp. circ. flow			176.4	
Est. P vap, psia			64.630	
Percent max circ flow			0.900	
Min. Motor pressure, psig			112.088	
Circ press/ differential			0.270	

Note 1. Efficiency at "Total pump flow"

Note 2. Total Circ Flow includes front bearing flow (does not affect te

Note 3. Motor efficiency includes windage loss (correct for specific gr

Note 4. System heat added with reverse circulation is "total heat" less

heat balance:

Total heat input, btu/min	1104.689		1104.689	1104.689
Standard circ (pump)	1105.871		0.000	1105.871
Motor heat, btu/min	412.198		412.198	412.198
Circ flow heat	412.638		0.000	412.638
Also motor heat, btu/min	412.198		412.198	412.198

FIGURE 9 Heat balance calculations

up or down. The sleeved bearings are located in the bearing housing. Alignment of the bearings is accomplished by a register fit between the bearing housings and the stator assembly.

**Diagnosics** Some canned motor pump manufacturers have developed diagnostic systems that monitor the condition of the internal wear surfaces of the pump. Because the



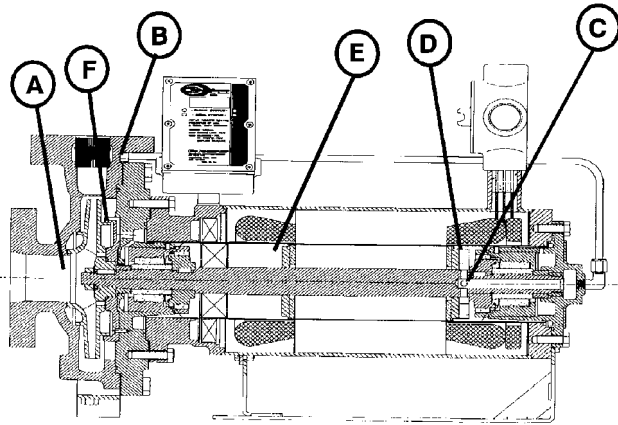


FIGURE 10A Pressurized circulation—points of reference

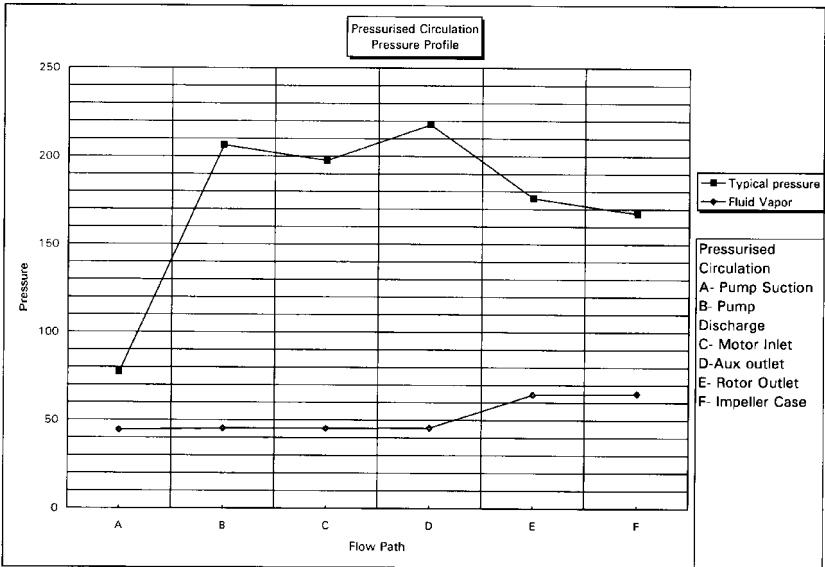


FIGURE 10B Pressurized circulation pressure profile

rotating components of the pump are not visible, even the direction of rotation can not be easily determined.

Advanced diagnostic systems indicate both axial and radial wear continuously. Continuous wear indication allows the pump user to trend the wear of the pump and schedule standard wear parts replacement long before a major failure occurs.

Remote outputs are also available on these diagnostic systems. These outputs include either a digital or analog signal, or a relay designed to shut down the pump—or signal an alarm—when a certain amount of bearing wear has occurred.

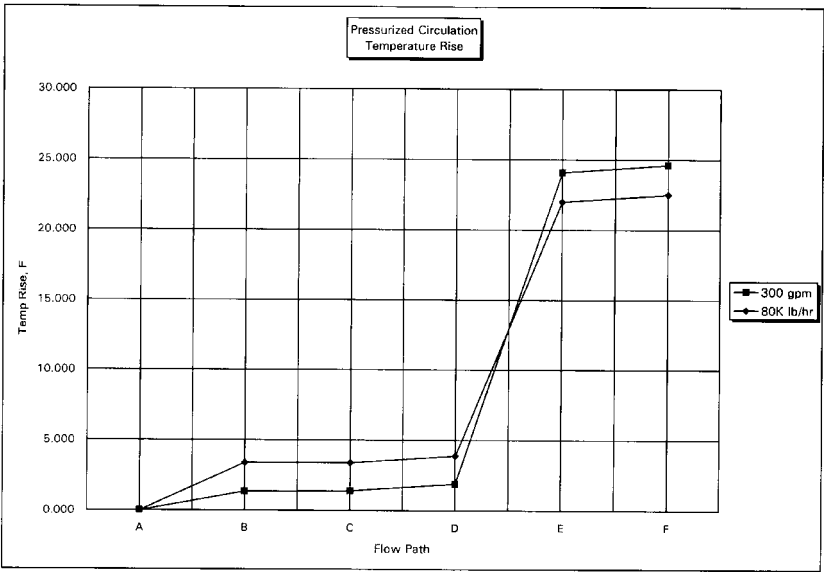


FIGURE 10C Pressurized circulation temperature rise

The diagnostic systems available today are perhaps the most significant advancement in the technology of sealless pumps. Figure 11, rotor position output data, illustrates the type of information available when using digital output linked to a data collection system.

Serial #	9630498-2								
DM ident.	964719								
program	crane2.1								
endplay	95								
update Global.XLM									
	DM ave	DM max	DM min	Dial	Switch				
forward	39.81	42	38	0	Zf=25				
rear	-19	-	-	95	Zr=EC				
DM ave	DM max	DM min	Dial	Display	GPM	DM min	DM max	DM ave	
37.26	39	35	7	0	0	92	99	96	
32.05	34	30	11	0	20	83	90	87	
36.12	38	34	6	0	60	90	97	94	
35.62	38	34	8	0	80	90	97	93	
29.41	31	27	14	0	100	78	85	82	
11.43	13	9	42	0	110	48	54	52	
7.9	10	5	45	1	120	41	49	46	

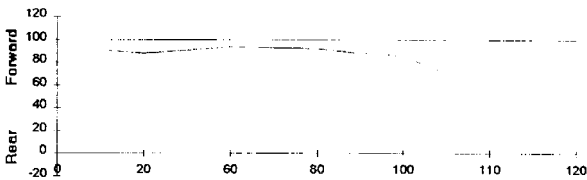


FIGURE 11 Rotor position output data

**REFERENCES AND FURTHER READING**

1. American National Standard for Sealless Centrifugal Pumps, ANSI/HI 5.1-5.6-2000, Hydraulic Institute, Parsippany, NJ www.pumps.org.
2. Hydraulic Institute ANSI/HI 2000 Edition Pump Standards, Hydraulic Institute, Parsippany, NJ www.pumps.org.
3. Sealless Pumps for Petroleum, Heavy Duty Chemical, and Gas Industry Services, API Standard 685, 2000, American Petroleum Institute, 1220 L Street, Northwest, Washington, D.C. www.api.org.

4. Eierman, R. "A User's View of Sealless Pumps—Their Economics, Reliability, and the Environment." *Proceedings of the Seventh International Pump Users Symposium*. Texas A&M University, College Station Texas, March 1990, pp. 127–133.
5. Hernandez, T. "A User's Engineering Review of Sealless Pump Design Limitations and Features." *Proceedings of the Eighth International Pump Users Symposium*. Texas A&M University, College Station, TX, March 1991, pp. 129–145.
6. Littlefield, D. "Sealless Centrifugal Pumps." *Proceedings of the Eleventh International Pump Users Symposium*. Texas A&M University, College Station, TX, March 1994, pp. 115–119.

---

# SECTION 2.3

---

# CENTRIFUGAL PUMP PERFORMANCE

---

## 2.3.1 CENTRIFUGAL PUMPS: GENERAL PERFORMANCE CHARACTERISTICS

C. P. KITTREDGE  
PAUL COOPER

---

### DEFINITIONS

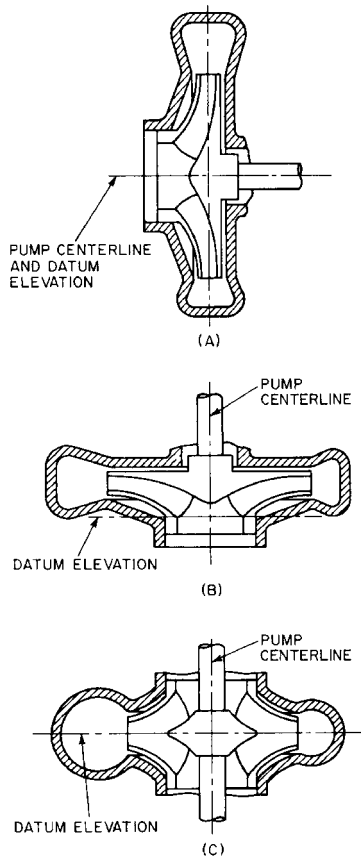
---

**Nomenclature** Many of the quantities involved in this subsection are also dealt with in Section 2.1. Therefore, a single nomenclature that applies to both sections appears at the beginning of Section 2.1. Differences in notation exist for some of these quantities as a result of the coexistence of different traditions and pump cultures, so the nomenclature shows the equivalence in each case. An example is the use in this subsection of “c” and “w” to denote absolute and relative velocity respectively, whereas the NASA system of capital letters V and W is employed in Section 2.1.

**Units** The units used in this subsection are as defined in the nomenclature unless specifically noted in the text. In particular, the primary units for this subsection are those of the U.S. Customary System (USCS). A distinction in USCS usage in this subsection is that the pound force (lbf) is represented simply as “lb”. In keeping with the commentary on SI units in the front matter of this handbook, conversions to SI units are given throughout this subsection, or the actual equivalent SI values are given in parentheses.

However, the number appearing in parentheses after the USGS value of specific speed  $n_s$  is the equivalent value of the universal specific speed  $\Omega_s$ . Note that the value of specific speed corresponding to the best efficiency point (BEP) operating conditions of the pump is the value of interest and is often used to identify the impeller geometry involved.

**Volume Flow Rate** Abbreviated to “flow rate” and known traditionally as “pump capacity”  $Q$ , this is the volume of liquid per unit time delivered by the pump. In USCS units,  $Q$  is expressed in U.S. gallons per minute or USgpm, for which the abbreviation “gpm” is



**FIGURE 1A through C** Elevation datum for defining pump head (Hydraulic Institute ANSI/HI 2000 Edition Pump Standards, Reference 27)

used. (1 US gallon = 231 in<sup>3</sup>.) For very large pumps, the units ft<sup>3</sup>/sec are used. The consistent SI units m<sup>3</sup>/s are implied when an SI value of  $Q$  is—unless the numerically convenient liters per second (l/s) are specifically called out.

**Datum for Pump Head** As defined in Eq. 3 and Figure 1 of Section 2.1, the total head has components of pressure, velocity, and elevation  $Z$  (or  $Z_e$ ). Because pump head  $H$  (more precisely  $\Delta H$ ) is the difference of the total heads evaluated at the discharge flange  $d$  and the suction flange  $s$  respectively, the elevation of the datum from which  $Z$  is measured cancels out. However, for purposes of identification, computing NPSH, and so on, the standard datum as shown in Figure 1 is used.

The standard datum for horizontal-shaft pumps is a horizontal plane through the centerline of the shaft (Figure 1a). For vertical-shaft pumps, the datum is a horizontal plane through the entrance eye of the first-stage impeller (Figure 1b) if single suction or through the centerline of the first stage impeller (Figure 1c) if double suction. Because pump head is the difference between the discharge and suction heads, it is not necessary that the standard datum be used, and any convenient datum may be selected for computing the pump head.

**Power** In USCS, the pump output is customarily given as liquid horsepower (lhp) or as water horsepower if water is the liquid pumped. It is given by

$$lhp = \frac{QH(\text{sp. gr.})}{3960} \quad (1)$$

where  $Q$  is in gallons per minute,  $H$  is in feet, and sp. gr. is specific gravity. If  $Q$  is in cubic feet per second, the equation becomes

$$lhp = \frac{QH(\text{sp. gr.})}{8.82} \quad (2)$$

In SI, the power  $P$  in watts (W) is given by

$$P = 9797QH (\text{sp. gr.}) \quad (3)$$

where  $Q$  is in cubic meters per second and  $H$  is in meters.

When  $Q$  is in liters per second and  $H$  is in meters

$$P = 9.797QH (\text{sp. gr.}) \quad (4)$$

**Efficiency** The pump efficiency  $\eta$  is the liquid horsepower divided by the power input to the pump shaft. The latter usually is called the brake horsepower (bhp). The efficiency may be expressed as a decimal or multiplied by 100 and expressed as percent. In this subsection, the efficiency will always be the decimal value unless otherwise noted. Some pump driver-units are so constructed that the actual power input to the pump is difficult or impossible to obtain. Typical of these is the "canned" pump for volatile or dangerous liquids. In such case, only an *overall efficiency* can be obtained. If the driver is an electric motor, this is called the *wire-to-liquid efficiency* or, when water is the liquid pumped, the *wire-to-water efficiency*.

## CHARACTERISTIC CURVES

**Pump with Non-Viscous Flow and Zero Slip** The basic shapes of centrifugal pump performance characteristics arising from various geometries can be ascertained and compared without the necessity of evaluating the slip. (Illustrated in Figure 15 of Section 2.1, the slip phenomenon is explained in the related discussion<sup>1</sup>.) For this purpose, one employs the artifice of non-viscous flow through an impeller with an infinite number of blades having infinitesimal thickness and that therefore produce neither structural (geometric) nor flow (boundary layer) blockage. The result is the ideal head for no slip or blockage  $H_e$  as given by Eq. 5 (cf. Eq. 15b of Section 2.1):

$$H_e = \frac{u_2 c_{u2}}{g} - \frac{u_1 c_{u1}}{g} \quad (5)$$

The velocity components in Eq. 5 can be seen in the velocity diagrams of Figure 2, slip being neglected. Generally the inlet swirl term is small, and Eq. 5 can be approximated by

$$H_e \cong \frac{u_2 c_{u2}}{g} \quad (6)$$

As shown in Figure 2b, the absolute velocity vector  $c$  may be resolved into the meridional, or radial, velocity  $c_m$  and the peripheral velocity  $c_u$ . From the geometry of the figure

$$c_{u2} = u_2 - \frac{c_{m2}}{\tan \beta_2} \quad (7)$$

which, substituted into Eq. 6, gives

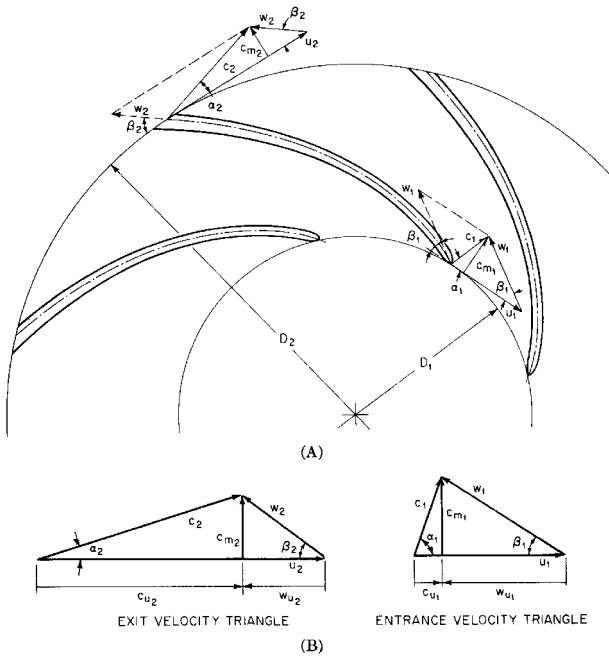


FIGURE 2A and B Velocity diagrams for radial-flow impellers, neglecting slip and blockage

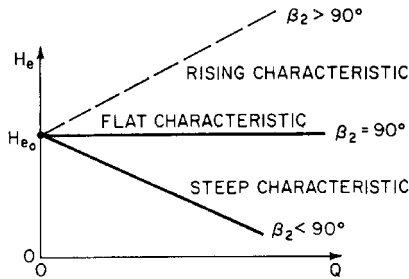


FIGURE 3 Head-versus-flow rate characteristics for non-viscous, zero-slip impeller flow

$$H_e = \frac{u_2^2}{g} - \frac{u_2 c_{m2}}{g \tan \beta_2} \quad (7)$$

Neglecting leakage flow, the meridional velocity  $c_m$  must be proportional to the capacity  $Q$ . With the additional assumption of constant impeller speed, Eq. 8 becomes

$$H_e = k_1 - k_2 Q \quad (8)$$

in which  $k_1$  and  $k_2$  are constants, with the value of  $k_2$  dependent on the value of the vane angle  $\beta_2$ . Figure 3 shows the  $H_e$ - $vs$ - $Q$  characteristics for the three possible conditions on the vane angle at exit  $\beta_2$ . The second right-hand term in Eq. 5 may be treated in like manner to the foregoing and included in Eqs. 8 and 9. The effect on Figure 3 would be to change



the value of  $H_e = u_2^2/g$  at  $Q = 0$  and the slopes of the lines, but all head-flow rate characteristics would remain straight lines.

**Viscous Flow with Slip** The real flow situation involves friction losses in an impeller with a finite number of relatively widely spaced blades. Thus, slip occurs, reducing the exit flow angle  $\beta_{f,2}$  below that of the blade  $\beta_2$ , (or, more precisely,  $\beta_{b,2}$ ) which in turn reduces  $c_{u2}$  (cf. Figure 15 of Section 2.1). Therefore, the ideal head  $H_i$  drops below  $H_e$ . Moreover, losses and recirculation occur to cause additional deviation of pump head  $H$  from  $H_e$ . While CFD flow analysis can be employed to predict  $H$  with fair accuracy<sup>2</sup>, lesser means, such as one-dimensional analysis, require experienced correlation and calibration skills to make such predictions. Therefore, many engineers commonly depend on testing and empirical modification of test results on the exact or similar geometry to make the final determination of the performance characteristics of a pump. This effort involves constant-speed plots of data as shown in the example of Figure 4.

Pumps are designed to operate at the point of best efficiency. The head, power, and flow rate at best efficiency, often called the *normal* values, are indicated in this subsection by  $H_n$ ,  $P_n$ , and  $Q_n$  respectively. Sometimes a pump may be operated continuously at a flow rate slightly above or below  $Q_n$ . In such case, the actual operating point is called the *rated* or *guarantee* point if the manufacturer specified this capacity in the guarantee. It is unusual to operate a pump continuously at a flow rate at which the efficiency is much below the maximum value. Apart from the unfavorable economics, the pump may be severely damaged by continued off-design operation, as described later.

**Backward-Curved Blades,  $\beta_2 < 90^\circ$**  Figure 4 shows the characteristics of a double-suction pump with backward-curved blades,  $\beta_2 = 23^\circ$ . The impeller discharged into a single volute casing, and the specific speed was  $n_s \approx 2200$  ( $\Omega_s \approx 0.8$ ) at best efficiency. At shut-off ( $Q = 0$ ), Eq. 8 predicts  $H_e$  to be 374 ft (114 m), whereas the pump actually developed about 210 ft (64 m), and this head remained nearly constant for the range  $0 < Q < 1000$  gpm (63 l/s). For  $Q > 1000$  gpm (63 l/s), the head decreased with increasing capacity but not in the linear fashion predicted by Eq. 9. At best efficiency, where  $Q_n = 3200$  gpm (202 l/s), Eq. 8 predicts  $H_e = 281$  ft (86 m), whereas the pump actually developed  $H_n = 164$  ft (50 m).

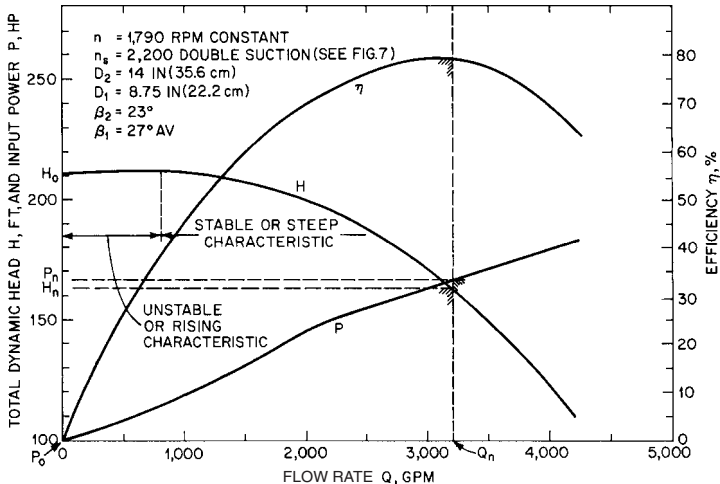


FIGURE 4 Typical pump characteristics, backward-curved blades (ft  $\times$  0.3048 = m; hp  $\times$  745.7 = W; gpm  $\times$  0.06309 = l/s)

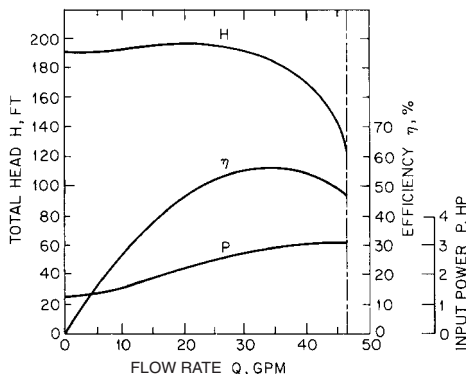
**Radial Blades,  $\beta_2 = 90^\circ$**  Large numbers of radial-blade pumps are used in many applications, from cellar drainers, cooling-water pumps for internal combustion engines, and other applications where low first cost is more important than high efficiency to highly engineered pumps designed for very high heads. The impellers are rarely more than 6 in (15 cm) in diameter, but the speed range may be from a few hundred to 30,000 rpm or more. The casings usually are concentric with the impellers and have one or more discharge nozzles that act as diffusers. The impellers usually are open, with three or more flat blades. The clearance between blades and casing is relatively large for easy assembly. Such pumps exhibit a flat head-capacity curve from shutoff to approximately 75% of best efficiency flow rate, and beyond this flow the head-flow curve is steep. The pumps develop a higher head, up to 8000 ft (2400 m) per stage, than pumps with backward-curved blades, but the efficiency of the former usually is lower. (See also Subsection 2.2.1.)

Figure 5 shows the characteristics of a pump as reported by Rupp.<sup>3</sup> The impeller was fully shrouded,  $D = 5.25$  in (13.3 cm), and fitted with 30 blades of varying length. The best efficiency,  $\eta = 55\%$ , was unusually high for the specific speed  $n_s = 475$  (0.174), as may be seen from Figure 6. The head-flow curve showed a rising (unstable) characteristic for  $0 < Q < 25$  gpm (1.6 l/s) and a steep characteristic for  $Q > 25$  gpm (1.6 l/s).

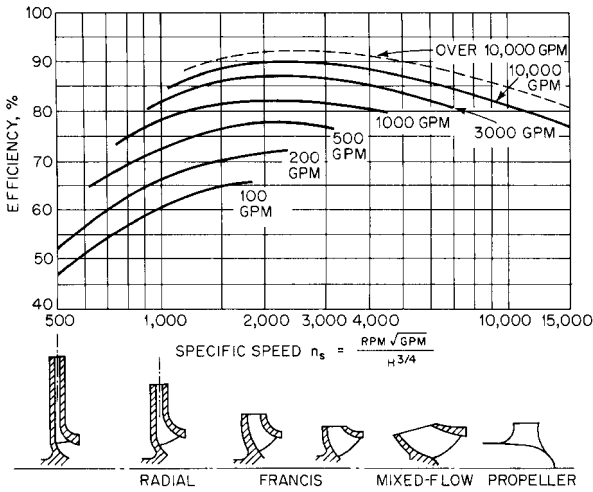
Figure 7 shows the characteristics of a pump as reported by Barske.<sup>4</sup> The impeller was open,  $D \approx 3$  in (7.6 cm), and fitted with six radial tapered blades. The effective  $\beta_2$  may have been slightly greater than  $90^\circ$  due to the taper. At 30,000 rpm, the best efficiency was more than 35% at  $n_s = 355$  (0.130), which is much higher than for a conventional pump of this specific speed and capacity (Figure 6). The head-flow curve showed a nearly flat characteristic over most of the usable range, as predicted by Eq. 8, but the head was always lower than  $H_c$ . The smooth concentric casing was fitted with a single diffusing discharge nozzle. When two or more nozzles were used, the head-flow curves showed irregularities at low flow rates and became steep at high flow rates.

Manson<sup>5</sup> has reported performance characteristics for jet engine fuel pumps having straight radial blades in enclosed impellers. The head curves showed unstable characteristics at low flow rates and steep characteristics at higher flow rates. The best efficiency reported was 54.7% for an impeller diameter of 3.300 in (8.382 cm) and speed  $n = 28,650$  rpm.

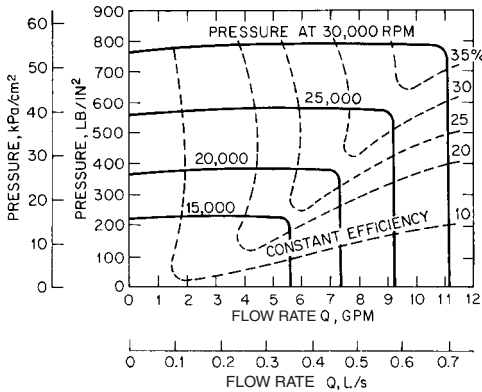
**Forward-Curved Blades,  $\beta_2 > 90^\circ$**  Pumps with forward-curved blades have been proposed,<sup>6</sup> but the research necessary to achieve an efficient design appears never to have been carried out. Tests have been made of conventional, backward-curved-blade, double-suction pumps with the impellers mounted in the reversed position but with rotation correct for the volute casing. As tested, these pumps therefore had forward-curved blades.



**FIGURE 5** Pump characteristics, radial blades (ft  $\times$  0.3048 = m; hp  $\times$  745.7 = W; gpm  $\times$  0.06309 = l/s) (Reference 3)



**FIGURE 6** Pump efficiency versus specific speed and size ( $\text{gpm} \times 0.06309 = 1/\text{s}$ ) (Flowsolve Corporation)  
 $(\Omega_s = n/2733)$



**FIGURE 7** Pump characteristics, radial blades ( $\text{lb}/\text{in}^2 \times 6.894 = \text{kPa}$ ;  $\text{gpm} \times 0.06309 = 1/\text{s}$ ) (Reference 4)

Table 1 shows the pertinent results for six different pumps. Both flow rate and efficiency were drastically reduced, and there was only a modest increase in head for five of the six pumps. The sixth pump showed a 38% increase in head over that obtained with the impeller correctly mounted. Published estimates<sup>7,8</sup> of the head-flow curves to be expected from reversed impellers predict an unstable characteristic at the low end of the flow rate range and a steep characteristic at the high end of the range.

**PERFORMANCE EFFECTS**

**Classification of Curve Shapes** A useful method for comparing characteristics of pumps of different specific speeds is to normalize on a selected operating condition, usually best efficiency. Thus,

**TABLE 1** Effects of reversed mounting of impeller

Number of stages	Specific speed per stage $n_s$ ( $\Omega_s$ )	Percent of normal shutoff head	Percent of normal values at best efficiency			
			Head	Flow Rate	Power	Efficiency
2	828 (0.303)	86	111	65	104	71
2	1024 (0.375)	82	112	88	145	68
1	1240 (0.454)	75	105	38.5	68.5	59
1	1430 (0.523)	82	106	69.7	138	53.5
1	2570 (0.940)	74.5	117	62	138	52.5
1	2740 (1.003)	77.5	138	61.5	180	47

Source: Flowsolve Corporation

$$q = \frac{Q}{Q_n} \quad h = \frac{H}{H_n} \quad p = \frac{P}{P_n} \quad (10)$$

where the subscript  $n$  designates values for the best efficiency point. Figures 8, 9, and 10 show approximate performance curves normalized on the conditions of best efficiency and for a wide range of specific speeds as defined in Table 2. These curves are applicable to pumps of any size because absolute magnitudes have been eliminated. In Figure 8, curves 1 and 2 exhibit a *rising head* or *unstable* characteristic where the head increases with increasing flow rate over the lower part of the flow rate range. This may cause instability at heads greater than the shutoff value, particularly if two or more pumps are operated in parallel. Curve 3 exhibits an almost constant head at low flow rates and is often called a *flat* characteristic. Curves 4 to 7 are typical of a *steep* or *stable head* characteristic, in which the head always decreases with increasing flow rate. Although the shape of the head-flow curve is primarily a function of the specific speed, the designer has some control through selection of the vane angle  $\beta_2$ , number of impeller vanes  $n_b$ , and capacity coefficient  $\phi = c_{m2}/u_2$ , as described in Section 2.1 (see also Figure 2). For pumps having a single-suction specific speed approximately 5000 (1.83) and higher, the power is at its maximum at shutoff and decreases with increasing flow rate. This may require an increase in the power rating of the driving motor over that required for operation at normal capacity.

**Efficiency** The efficiency  $\eta$  is the product of three component efficiencies (defined in Section 2.1):

$$\eta = \eta_m \eta_v \eta_h \quad (11)$$

The mechanical efficiency  $\eta_m$  accounts for the bearing, stuffing box, and all disk-friction losses including those in the wearing rings and balancing disks or drums if present. The volumetric efficiency  $\eta_v$  accounts for leakage through the wearing rings, internal labyrinths, balancing devices, and glands. The hydraulic efficiency  $\eta_h$  accounts for liquid friction losses in all through-flow passages, including the suction elbow or nozzle, impeller, diffusion vanes, volute casing, and the crossover passages of multistage pumps. Figure 11 shows an estimate of the losses from various sources in double-suction single-stage pumps having at least 12-in (30-cm) discharge pipe diameter. Minimum losses and hence maximum efficiencies are seen to be in the vicinity of  $n_s \approx 2500$  (0.91), which agrees with Figure 6.

**Effects of Pump Speed** Increasing the impeller speed increases the efficiency of centrifugal pumps. Figure 7 shows a gain of about 15% for an increase in speed from 15,000 to 30,000 rpm. The increases are less dramatic at lower speeds. For example, Ippen<sup>9</sup> reported about 1% increase in the efficiency of a small pump,  $D = 8$  in (20.3 cm) and  $n_s = 1992$  (0.73), at best efficiency, for an increase in speed from 1240 to 1880 rpm. Within limits, the cost of the pump and driver usually decreases with increasing speed. Abrasion

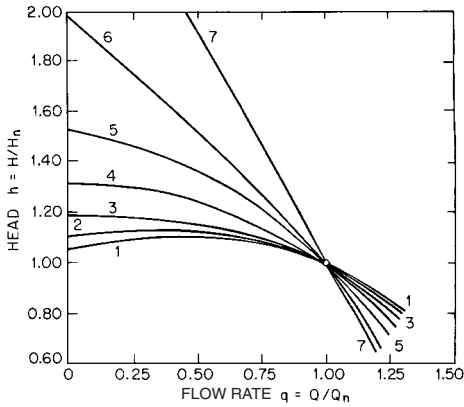


FIGURE 8 Head curves for several specific speeds, as defined in Table 2 (Reference 12)

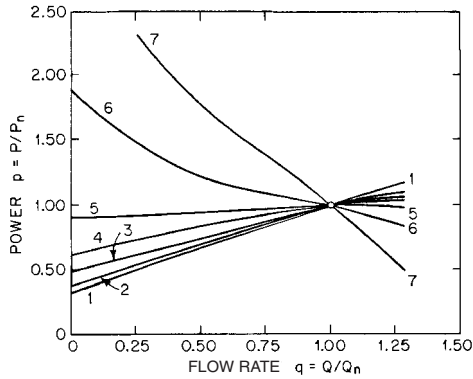


FIGURE 9 Power curves for several specific speeds, as defined in Table 2 (Reference 12)

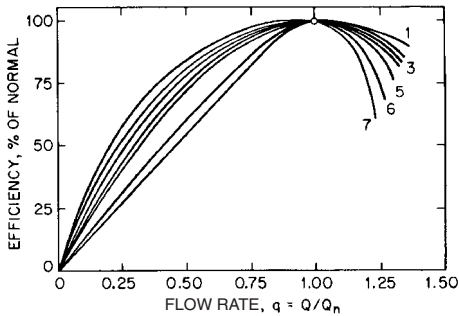
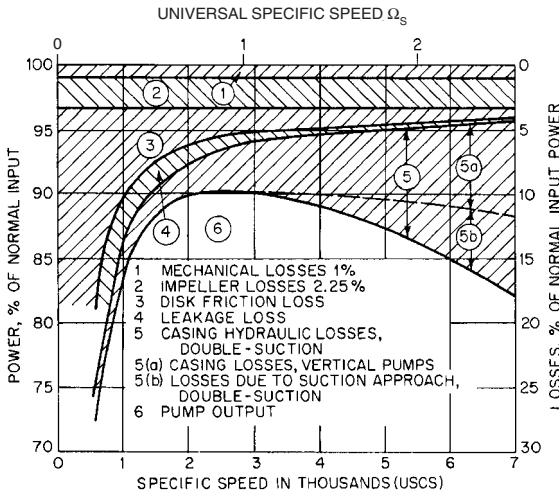


FIGURE 10 Efficiency curves for several specific speeds, as defined in Table 2 (Reference 12).

**TABLE 2** Characteristic curves as a function of specific speed (Figures 8, 9, and 10)

Curve Number on Figures 8, 9, and 10	USCS Specific Speed $n_s$	Metric (SI) Specific Speed $n_q$	Universal Specific Speed $\Omega_s$	Impeller Suction Configuration
1	900	17	0.33	Double
2	1500	29	0.55	Double
3	2200	43	0.80	Double
4	3000	58	1.10	Double
5	4000	77	1.46	Double
6	5700	110	2.09	Single
7	9200	178	3.37	Single

**FIGURE 11** Power balance for double-suction pumps at best efficiency (Reference 12)

and wear increase with increasing speed, particularly if the liquid contains solid particles in suspension. The danger of cavitation damage usually increases with increasing speed unless certain suction requirements can be met, as described later.

**Effects of Specific Speed** Figures 6 and 11 show that maximum efficiency is obtained in the range  $2000 (0.73) < n_s < 3000 (1.10)$ , but this is not the only criterion. Pumps for high heads and small flow rates occupy the range  $500 (0.18) < n_s < 1000 (0.37)$ . At the other extreme, pumps for very low heads and large flow rates may have  $n_s = 15,000 (5.49)$  or higher. For given head and flow rate, the pump having the highest specific speed that will meet the requirements probably will be the smallest and least expensive. However, Figure 9 of Section 2.1 shows that it will run at the highest speed and be subject to maximum wear and cavitation damage, as previously mentioned.

### Effects of Clearance

**WEARING-RING CLEARANCE** Details of wearing-ring construction are given in Subsection 2.2.1. Schematic outlines of two designs of rings are shown in Figure 12. The L-shaped construction shown in Figure 12a is very widely used with the close clearance between the cylindrical portions of the rings. Leakage losses increase and pump performance

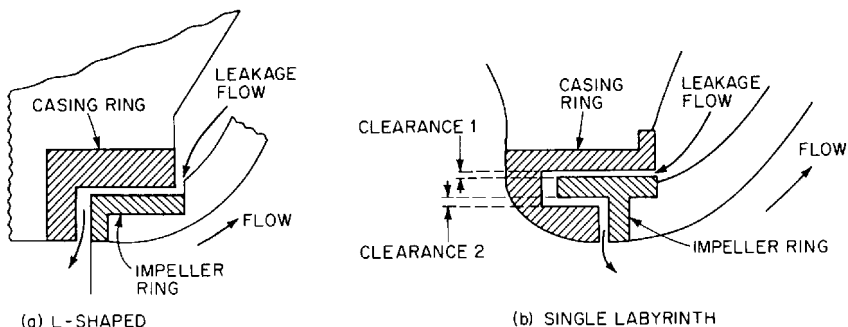


FIGURE 12A and B Typical wearing rings

**TABLE 3** Effects of increased wearing-ring clearance on centrifugal pump performance

Specific speed $n_s$ ( $\Omega_s$ )	Design head, ft (m)	Ring clearance, % of normal value	Percent of values at shutoff with normal ring clearance			Percent of values at best efficiency with normal ring clearance		
			$Q$	$H$	$P$	$\eta$	$H_0$	$P_0$
2100 (0.77)	63 (19.2)	178	100	98.3	98.9	99.4	97.0	100
...	...	356	100	97.5	99.0	98.5	93.6	98.2
...	...	688	100	96.0	98.9	97.1	91.2	94.8
...	...	1375	100	94.3	97.4	96.8	88.8	92.5
3500 (1.28)	65 (19.8)	354	100	90.0	99.1	90.8	85.0	96.2
4300 (1.57)	41(12.5)	7270	62	65.5	81.7	49.8	44.3	106
4800 (1.76)	26 (7.9)	5220	96	78.8	89.2	84.8	78.2	83.3

Source: Flowsolve Corporation

falls off as the rings wear. Table 3 shows some of the effects of increasing the clearance of rings similar to Figure 12a.

The labyrinth construction shown in Figure 12b has been used to increase the leakage path without increasing the axial length of the rings. If the pressure differential across these rings is high enough, the pump shaft may take on lateral vibrations with relatively large amplitude and long period, which can cause serious damage. One remedy for these vibrations is to increase clearance 2 in Figure 12b relative to clearance 1, at the expense of an increased leakage flow. High-pressure breakdown through plain rings may cause vibration,<sup>10</sup> but this is not usually a serious problem. It is considered good practice to replace or repair wearing rings when the nominal clearance has doubled. The presence of abrasive solids in the liquid pumped may be expected to increase wearing-ring clearances rapidly.

**VANE-TIP CLEARANCE** Many impellers are made without an outer shroud and rely on close running clearances between the vane tips and the casing to hold leakage across the vane tips to a minimum. Although this construction usually is not used with pumps having specific speeds less than about 6000 (2.20), Wood et al.<sup>11</sup> have reported good results with semi-open impellers at  $1800 (0.66) \leq n_s \leq 4100 (1.50)$ . It appears that both head and efficiency increase with decreasing tip clearance and are quite sensitive to rather small changes in clearance. Reducing the tip clearance from about 0.060 in (1.5 mm) to about 0.010 in (0.25 mm) may increase the efficiency by as much as 10%. Abrasive solids in the liquid pumped probably will increase tip clearances rapidly.

## MODIFICATIONS TO IMPELLER AND CASING

**Diameter Reduction** To reduce cost, pump casings usually are designed to accommodate several different impellers. Also, a variety of operating requirements can be met by changing the outside diameter of a given radial impeller. Eq. 6 shows that the head should be proportional to  $(nD)^2$  provided that the exit velocity triangles (Figure 2b) remain similar before and after cutting, with  $w_2$  always parallel to itself as  $u_2$  is reduced. This can be achieved if the impeller meridional exit area  $A_{m,2}$  is the same before and after cutting—and if the flow angle  $\beta_{f,2}$  (Figure 15, Section 2.1) also stays the same. [ $\beta_{f,2}$  would stay the same if the blade angle  $\beta_2 (= \beta_{b,2})$  does, the difference being due to slip velocity  $V_s$  that should also scale down with  $D$ .] For radial discharge impellers, area  $A_{m,2}$  equals  $\pi D b_2$  (minus blade and boundary layer blockage) and requires that  $b_2$  increase as  $D$  decreases. This is typical of many impellers—as is constancy of  $\beta_2$  over the cutting range—and, together with Eqs. 27–33 of Section 2.1, leads to the so-called “affinity laws” for predicting performance:

$$\frac{Q_1}{Q_2} = \frac{n_1 D_1}{n_2 D_2} \quad (12a)$$

$$\frac{H_1}{H_2} = \frac{n_1^2 D_1^2}{n_2^2 D_2^2} \quad (12b)$$

$$\frac{P_1}{P_2} = \frac{n_1^3 D_1^3}{n_2^3 D_2^3} \quad (12c)$$

which apply only to a given impeller with altered  $D$  and constant efficiency but *not* to a geometrically similar series of impellers. The assumptions on which Eqs. 12 were based are rarely if ever fulfilled in practice, so exact predictions by the equations should not be expected. A common example is the low- $n_s$  radial discharge impeller with parallel radial hub and shroud profiles over most of the path from inlet to exit (Figure 6). Here,  $A_{m,2}$  decreases with cutting, and  $H$  falls more than would be predicted by Eq. 12b. [This type of impeller is often found in multistage pumps, particularly those in which the designer, driven by cost reduction goals, has minimized a) the axial length occupied by each stage and b) the number of stages, thereby pushing down the  $n_s$  of the individual stage to the point that a tolerable sacrifice in efficiency results.]

**RADIAL DISCHARGE IMPELLERS** Impellers of low specific speed may be cut successfully provided the following items are kept in mind:

1. The angle  $\beta_2$  may change as  $D$  is reduced, but this usually can be corrected by filing the blade tips. (See the discussion on blade-tip filing that follows.)
2. Tapered blade tips will be thickened by cutting and should be filed to restore the original shape. (See the discussion below on blade-tip filing.)
3. Bearing and stuffing box friction remain constant, but disk friction should decrease with decreasing  $D$ .
4. The length of flow path in the pump casing is increased by decreasing  $D$ .
5. Because  $c_{m1}$  is smaller at the reduced capacity, the inlet triangles no longer remain similar before and after cutting, and local flow separation may take place near the blade entrance tips.
6. The second right-hand term in Eq. 5 was neglected in arriving at Eqs. 12, but it may represent a significant decrease in head as  $D$  is reduced.
7. Some blade overlap should be maintained after cutting. Usually the initial blade overlap decreases with increasing specific speed, so the higher the specific speed, the less the allowable diameter reduction.
8. Diameter reductions greater than from 10 to 20% of the original full diameter of the impeller are rarely made.



Most of the losses are approximately proportional to  $Q^2$ , and hence to  $D^2$  by Eq. 12. Because the power output decreases approximately as  $D^3$ , it is reasonable to expect the maximum efficiency to decrease as the wheel is cut, and this often is the case. By Eq. 12 and the  $n_s$ -definition (Eq. 38a of Section 2.1), the product  $n_s D$  should remain constant so the specific speed at best efficiency increases as the wheel diameter is reduced (Table 4).

The characteristics of the pump shown in Figure 13 may be used to illustrate reduction of diameter at constant speed. Starting with the best efficiency point and  $D = 16\frac{5}{16}$  in (41.4 cm), let it be required to reduce the head from  $H = 224.4$  to  $H' = 192.9$  ft (68.4 m to 58.8 m) and to determine the wheel diameter, capacity, and power for the new conditions.

Because the speed is constant, Eqs. 12 may be written

$$H = k_H Q^2 \quad \text{and} \quad P = k_p Q^3 \quad (13)$$

where  $k_H$  and  $k_p$  may be obtained from the known operating conditions at  $D = 16\frac{5}{16}$  in (41.4 cm). Plot a few points for assumed capacities and draw the curve segments as shown by the solid lines in Figures 13b and 13c. Then, from Eqs. 12

$$D' = D\sqrt{H'/H} \quad Q' = Q\sqrt{H'/H} \quad P' = P(H'/H)^{3/2} \quad (14a)$$

$$D' = D(Q'/Q) \quad H' = H(Q'/Q)^2 \quad P' = P(Q'/Q)^3 \quad (14b)$$

from which  $D = 15\frac{1}{8}$  in (38.4 cm),  $Q = 3709$  gpm (234 l/s), and  $P' = 215.5$  hp (160.7 kW). In Figure 13, the initial conditions were at points A and the computed conditions after cutting at points B. The test curve for  $D = 15\frac{1}{8}$  in (38.4 cm) shows the best efficiency point *a* at a lower flow rate than predicted by Eqs. 14, but the head curve satisfies the predicted values very closely. The power prediction was not quite as good. Table 4 and Figure 13 give actual and predicted performance for three impeller diameters. The error in predicting the best efficiency point was computed by (predicted value minus test value) (100)/(test value). As the wheel diameter was reduced, the best efficiency point moved to a lower flow rate than predicted by Eq. 14 and the specific speed increased, showing that the conditions for Eqs. 12 to hold were not maintained.

Wheel cutting should be done in two or more steps with a test after each cut to avoid too large a reduction in diameter. Figure 14 shows an approximate correction, given by Stepanoff,<sup>12</sup> that may be applied to the ratio  $D'/D$  as computed by Eqs. 12 or 14. The accuracy of the correction decreases with increasing specific speed. Figure 15 shows a correction proposed by Rüttschi<sup>13</sup> on the basis of extensive tests on low-specific-speed pumps. The corrected diameter reduction  $\Delta D$  is the diameter reduction  $D - D'$  given by Eqs. 14 and multiplied by  $k$  from Figure 15. The shaded area in Figure 15 indicates the range of scatter of the test points operating at or near maximum efficiency. Near shutoff the values of  $k$  were smaller and at maximum flow rate the values of  $k$  were larger than shown in Figure 15. Table 5 shows the results of applying Figures 14 and 15 to the pump of the preceding example.

There is no independent control of  $Q$  and  $H$  in impeller cutting, although  $Q$  may be increased somewhat by underfiling the blade tips as described later. The flow rate and power will automatically adjust to the values at which the pump head satisfies the system head-flow curve.

**MIXED-FLOW IMPELLERS** Diameter reduction of mixed-flow impellers is usually done by cutting a maximum at the outside diameter  $D_o$  and little or nothing at the inside diameter  $D_i$ , as shown in Figure 16. Stepanoff<sup>14</sup> recommends that the calculations be based on the average diameter  $D_{av} = (D_i + D_o)/2$  or estimated from the blade-length ratio  $FK/EK$  or  $GK/EK$  in Figure 16d. Figure 16 shows a portion of the characteristics of a mixed-flow impeller on which two cuts were made as in Figure 16b. The calculations were made by Eqs. 14 using the mean diameter

$$D_m = \sqrt{(D_o^2 + D_i^2)/2}$$

instead of the outside diameter in each case. The predictions and test results are shown in Figure 16 and Table 6. It is clear that the actual change in the characteristics far exceeded

**TABLE 4** Predicted characteristics at different impeller diameters on a radial-flow pump

$D$ , in (cm)	Test values					Predicted from $D = 16\frac{5}{16}$ in (41.4 cm)			Predicted from $D = 15\frac{1}{8}$ in (38.4 cm)		
	$Q$ , gpm (l/s)	$H$ , ft (m)	$P$ , hp (kW)	$n_s$ ( $\Omega_s$ )	$n_s D$ ( $\Omega_s D$ )	$Q'$ , gpm (l/s)	$H'$ , ft (m)	$P'$ , hp (kW)	$Q'$ , gpm (l/s)	$H'$ , ft (m)	$P'$ , hp (kW)
$16\frac{5}{16}$ (41.4)	4000 (252)	224.4 (68.4)	270.4 (201.6)	1953 (0.7146)	31,860 (29.54)	...	...	...	3888 (245)	227.3 (69.3)	272.2 (203.0)
$15\frac{1}{8}$ (38.4)	3600 (227.1)	195.4 (59.6)	217.0 (161.8)	2055 (0.7519)	31,080 (28.87)	3709 (234)	192.9 (58.8)	215.5 (160.7)	...	...	...
14 (35.6)	3200 (201.9)	163.6 (49.9)	167.2 (124.7)	2214 (0.8101)	31,000 (28.84)	3433 (217)	165.3 (50.4)	170.9 (127.4)	3332 (210.2)	167.4 (51.0)	172.1 (128.3)
						7.28% error <sup>a</sup>	1.03% error <sup>a</sup>	2.33% error <sup>a</sup>	4.13% error <sup>a</sup>	2.33% error <sup>a</sup>	2.93% error <sup>a</sup>

<sup>a</sup>Error in predicting best efficiency point.

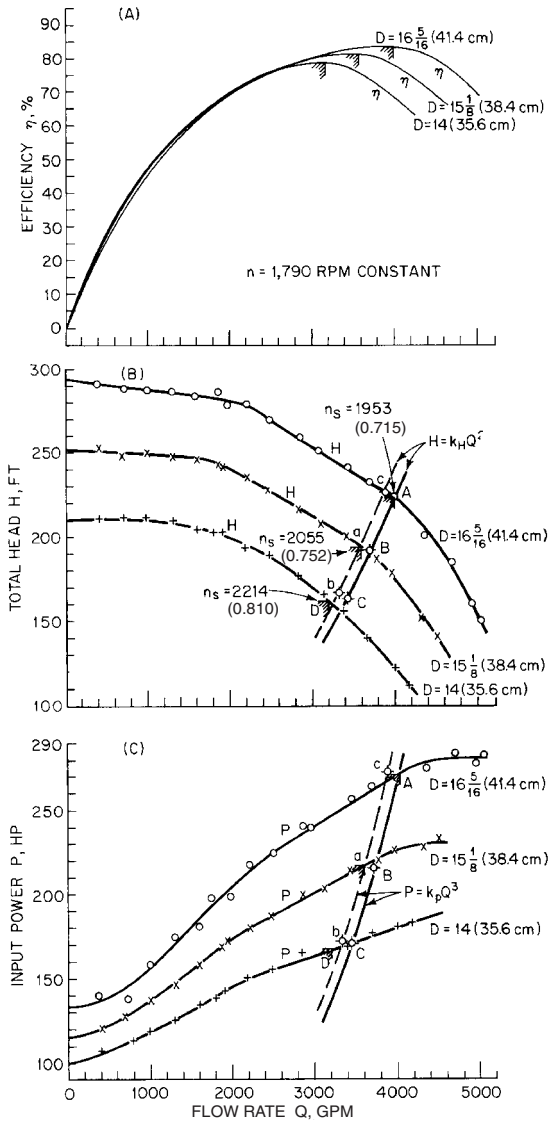


FIGURE 13A through C Diameter reduction of radial-flow impeller ( $\text{gpm} \times 0.06309 = \text{l/s}$ ).  $D$  is measured in inches (centimeters).

the predicted values. Except for the use of the mean diameters, the procedure was essentially the same as that described for Figure 13, and all points and curves are similarly labeled. The corrections given in Figure 14 would have made very little difference in the computed diameter reductions, and those of Figure 15 were not applicable to impellers having specific speeds greater than  $n_s = 2000$  (0.73). In this case, the product  $n_s D_m$  did not remain constant and the maximum efficiency increased as  $D_m$  was reduced. Although the

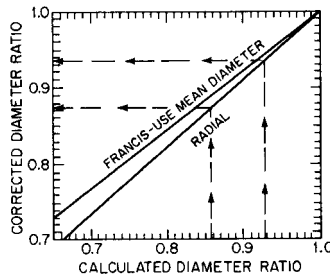


FIGURE 14 Corrections for calculated impeller diameter reductions (Reference 12)

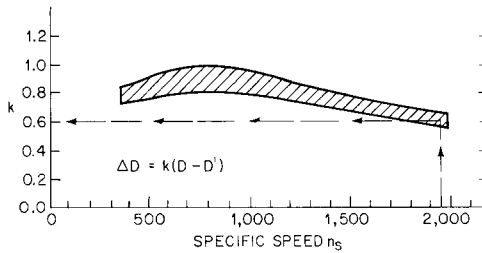


FIGURE 15 Corrections for calculated impeller diameter reductions (Reference 13). ( $\Omega_s = n_s/2733$ )

TABLE 5 Impeller diameter corrections

$D$ before cutting	in	16.3125	16.3125
$D'$ predicted by Eqs. (14)	in	15.125	14.000
$D'$ corrected by Figure 14	in	15.25 <sup>a</sup>	14.26 <sup>b</sup>
$D'$ corrected by Figure 15	in	15.60 <sup>c</sup>	14.93 <sup>d</sup>

<sup>a</sup> $D'/D = 15.125/16.3125 = 0.927$ ; by Figure 14, corrected  $D'/D = 0.935$ . Corrected  $D' = (0.935)(16.3125) = 15.25$  in.

<sup>b</sup> $D'/D = 14.000/16.3125 = 0.858$ ; by Figure 14, corrected  $D'/D = 0.874$ . Corrected  $D' = (0.874)(16.3125) = 14.26$  in.

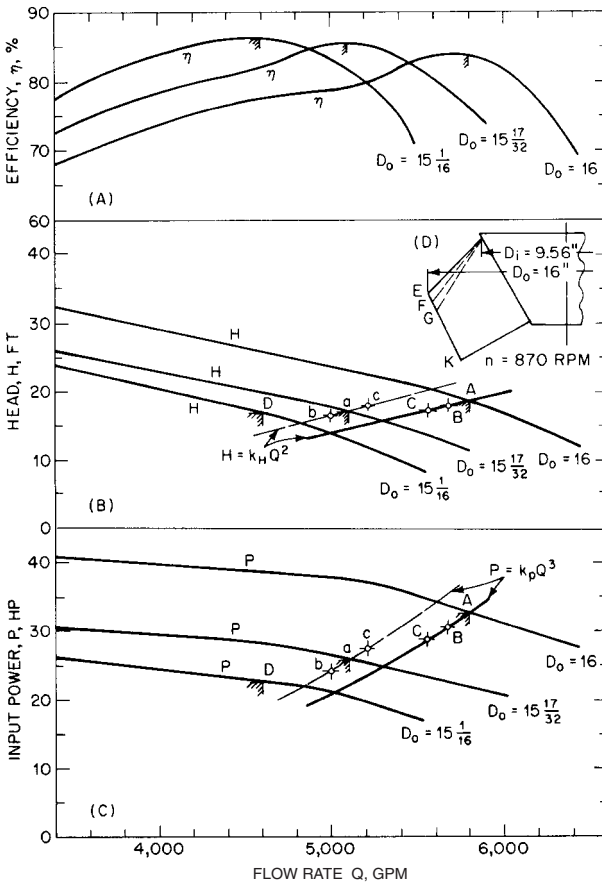
<sup>c</sup> $D - D' = 16.3125 - 15.125 = 1.1875$ ; by Figure 15,  $K \cong 0.6$  at  $n_s = 1,953$ . Corrected  $D - D' = (0.6)(1.1875) = 0.7125$  and corrected  $D' = 16.3125 - 0.7125 = 15.60$  in.

<sup>d</sup> $D - D' = 16.3125 - 14.000 = 2.3125$ ; by Figure 15,  $K \cong 0.6$  at  $n_s = 1,953$ . Corrected  $D - D' = (0.6)(2.3125) = 1.3875$  and corrected  $D' = 16.3125 - 1.3875 = 14.93$  in.

changes in diameter were small, the area of blade removed was rather large for each cut. The second cut eliminated most of the blade overlap.

The characteristics of mixed-flow impellers can be changed by cutting, but very small cuts may produce a significant effect. The impellers of propeller pumps are not usually subject to diameter reduction.

**Shaping Blade Tips** If the discharge tips of the impeller blades are thick, performance usually can be improved by filing over a sufficient length of blade to produce a long, gradual taper. Chamfering, or rounding, the discharge tips may increase the losses and should never be done. Reducing the impeller diameter frequently increases the tip thickness.



**FIGURE 16A through C** Diameter reduction of mixed-flow impeller (ft  $\times$  0.3048 = m; in  $\times$  2.540 = cm; gpm  $\times$  0.06309 = l/s; hp  $\times$  0.7457 = kW)

**OVERFILING** This is shown at *B* in Figure 17, and the unfiled blade is shown at *A*. Usually there is little or no increase in the blade spacing  $d$  before and  $d_F$  after filing, so the discharge area is practically unchanged. Experience indicates that any change in the angle  $\beta_2$  due to overfiling usually produces a negligible change in performance.

**UNDERFILING** This is shown at *C* in Figure 17. If properly done, underfiling will increase the blade spacing from  $d$  to  $d_f$  and hence the discharge area, which lowers the average meridional velocity  $c_{m2}$ , at any given flow rate  $Q$ . The angle  $\beta_2$  usually is increased slightly. Figure 18A and Eq. 6 show that the head and consequently the power increase at the same flow rate. The maximum efficiency usually is improved and may be moved to a higher flow rate. At the same head, Figure 18B shows that both  $c_{m2}$  and the flow rate will increase. The change both in the area and in  $C_{m2}$  may increase the flow rate by as much as 10%. Table 7 shows the results of tests before and after underfiling the impeller blades of nine different pumps. In general, they confirm the foregoing predictions based on changes in area and in the velocity triangles.

**TABLE 6** Predicted characteristics at different impeller diameters on a mixed-flow pump

		Test values					Predicted from $D = 16.00$ (40.64 cm), $D_m = 13.17$ (33.45 cm)			Predicted from $D = 15.53$ (39.45 cm), $D_m = 12.89$ (32.74 cm)		
$D$ , in (cm)	$D_m$ , in (cm)	$Q$ , gpm (l/s)	$H$ , ft (m)	$P$ , hp (kW)	$n_s$	$n_s D_m$	$Q'$ , gpm (l/s)	$H'$ , ft (m)	$P'$ , hp (kW)	$Q'$ , gpm (l/s)	$H'$ , ft (m)	$P'$ , hp (kW)
16 (40.64)	13.17 (33.45)	5800 (365.9)	18.6 (5.67)	32.5 (24.2)	7385 (2.702)	97,300 (90.39)	...	...	...	5210 (329)	17.9 (5.46)	27.4 (20.4)
										-11.3% error	-3.91% error	-18.6% error
$15\frac{17}{32}$ (39.45)	12.89 (32.74)	5100 (321.8)	17.1 (5.21)	25.7 (19.2)	7385 (2.702)	95,200 (88.47)	5680 (358.4)	17.8 (5.43)	30.4 (22.7)			
							10.2% error <sup>a</sup>	4.50% error <sup>a</sup>	15.5% error <sup>a</sup>			
$15\frac{1}{16}$ (38.26)	12.62 (32.05)	4600 (290.2)	16.8 (5.12)	22.6 (17.1)	7100 (2.598)	89,600 (83.26)	5560 (350.8)	17.1 (5.21)	28.6 (21.6)	5000 (315.5)	16.4 (5.00)	24.1 (18.2)
							17.3% error <sup>a</sup>	1.75% error <sup>a</sup>	21.0% error <sup>a</sup>	8.00% error <sup>a</sup>	-2.44% error <sup>a</sup>	6.22% error <sup>a</sup>

<sup>a</sup>Error in predicting best efficiency point.

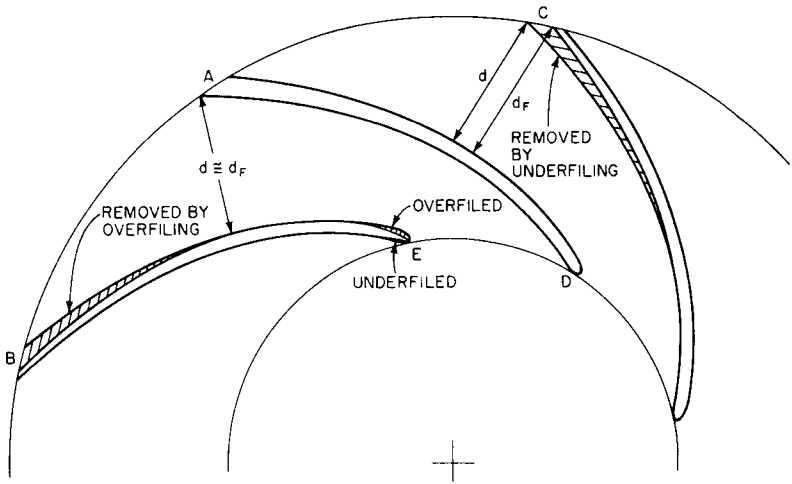


FIGURE 17 Underfiling and overfiling of blade tips

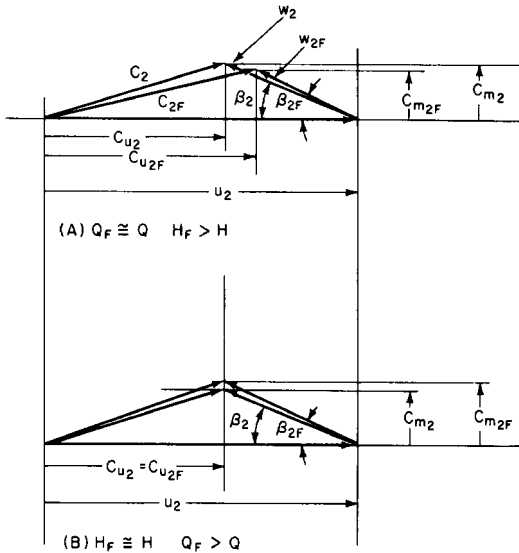


FIGURE 18 Discharge velocity triangles for underfiled blades (neglecting slip)

**INLET BLADE TIPS** If the inlet blade tips are blunt, as shown at *D* in Figure 17, the cavitation characteristics may be improved by sharpening them, as shown at *E*. In this case overfiling increases the effective flow area, which reduces  $c_{m1}$  for a given flow rate. If more area is needed, it may be advantageous to cut back part of the blade and sharpen the leading edge. Overfiling tends to increase  $\beta_1$ , which is incompatible with a decrease in  $c_{m1}$  (Figure 19). The increase in  $\beta_1$  increases the angle of attack of the liquid approaching the blade. In Figures 2 and 19,  $w_1$  is tangent to the centerline of the blade at entrance and  $w_0$

TABLE 7 Changes in performance when impeller blades are underfiled

Specific speed $n_s$	$\Omega_s$	No. of stages	Impeller diameter $D_2$ in (cm)		Change in blade spacing $d_p/d$	$\frac{H_F - H}{H}$ % <sup>b</sup>	Changes at best efficiency point after filing, %				
							$H_o^c$	$H$	$Q$	$P$	$\eta$
862	(0.3154)	1	11 $\frac{1}{2}$	(29.21)	1.13	4	1.5	4	0	9	-5
945	(0.3458)	2	8 $\frac{3}{8}$	(21.27)	1.05	5.5	0	3	4	-0.5	7.5 <sup>d</sup>
1000	(0.3659)	4	9 $\frac{1}{8}$	(23.18)	1.055	5.5	0	5.5	0	3	2.5
1080	(0.3952)	2	9 $\frac{13}{16}$	(24.92)	1.08	10	2.5	10	0	6.8	3
1525	(0.5580)	2	10 $\frac{1}{2}$	(26.67)	1.035	3.2	3	0.5	4.5	3.5	1.2
1950	(0.7135)	1	22	(55.88)	1.02	1.5	1	1.5	0	1.5	0
3300 <sup>e</sup>	(1.2075)	1	12	(30.48)	...	7.8	2.5	7.8	0	8.5	-0.6
3450 <sup>e</sup>	(1.2623)	1	30 $\frac{1}{2}$	(77.47)	...	6.5	0.5	6.5	0	7.8	-2.2
4300	(1.5734)	1	41 $\frac{1}{4}$	(104.8)	...	5	5	0	0.5	4.5 <sup>e</sup>	

<sup>a</sup>Double suction.

<sup>b</sup> $H_F$  is head after filing.

<sup>c</sup>Shutoff head.

<sup>d</sup>Due in part to changes in pump casing.

<sup>e</sup>Due in part to rounding of inlet blade tips.

Source: Flowserve Corporation

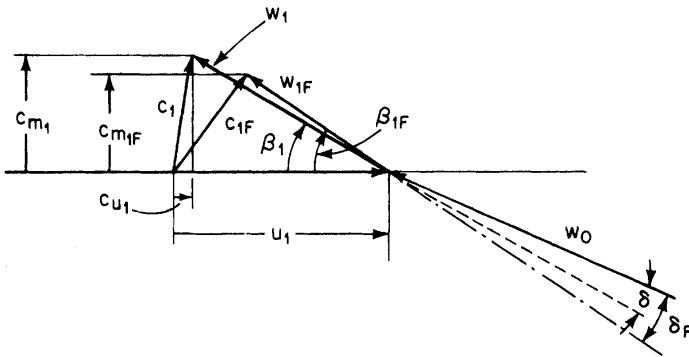


FIGURE 19 Effect of overfiling at inlet on the velocity triangle just inside the blades

is the velocity of the approaching liquid as seen by an observer moving with the blade. The angle  $\delta$  between  $w_0$  and  $w_1$  is the angle of attack, which increases to  $\delta_F$  after overfiling. Although the increase in  $\delta$  tends to increase the opportunity for the liquid to separate from the low-pressure face of the blade, this disadvantage usually is outweighed by the improvement that results when  $c_{m1}$  is reduced.\*

\*The distinction between a true velocity diagram formed just upstream of the impeller blades and the triangles shown just inside the blades in Figure 19 should be noted.  $w_1$  in this figure is shown aligned with the blade, having undergone an adjustment in direction via incidence from that of the approaching  $w_0$ . Only by plotting the velocity diagram just upstream of this point can one determine the true value of the circumferential component  $c_{u1}$  of the absolute velocity being delivered to the impeller by the upstream piping, vanes, and so on. It is this delivered value of  $c_{u1}$  that must be used in computing input or ideal head of the impeller (Eq. 15b, Section 2.1 or neglecting slip, Eq. 6 of this subsection). Thus  $w_0$  is properly the true  $w_1$  vector and should be understood as such (see Section 2.1).



**CASING TONGUE** The casing tongue or cutwater forms part of the throat of the discharge nozzle of many volute casings (Figure 20a, Section 2.1). Frequently the throat area is small enough to act as a throttle and reduce the maximum flow rate otherwise obtainable from the impeller. Cutting back the tongue increases the throat area and increases the maximum flow rate. The head-versus-flow rate characteristic is then said to *carry out farther*. Shortening the discharge nozzle may increase the diffusion losses a little and result in a slightly lower efficiency.

## CAVITATION

---

The formation and subsequent collapse of vapor-filled cavities in a liquid due to dynamic action are called *cavitation*. The cavities may be bubbles, vapor-filled pockets, or a combination of both. The local pressure must be at or below the vapor pressure of the liquid for cavitation to begin, and the cavities must encounter a region of pressure higher than the vapor pressure in order to collapse. Dissolved gases often are liberated shortly before vaporization begins. This may be an indication of impending cavitation, but true cavitation requires vaporization of the liquid. Boiling accomplished by the addition of heat or the reduction of static pressure without dynamic action of the liquid is arbitrarily excluded from the definition of cavitation.

When a liquid flows over a surface having convex curvature, the pressure near the surface is lowered and the flow tends to separate from the surface. *Separation* and *cavitation* are completely different phenomena. Without cavitation, a separated region contains turbulent eddying liquid at pressures higher than the vapor pressure. When the pressure is low enough, the separated region may contain a vapor pocket that fills from the downstream end,<sup>15</sup> collapses, and forms again many times each second. This causes noise and, if severe enough, vibration. Vapor-filled bubbles usually are present and collapse very rapidly in any region where the pressure is above the vapor pressure. Knapp<sup>16</sup> found the life cycle of a bubble to be on the order of 0.003 s.

Bubbles that collapse on a solid boundary may cause severe mechanical damage. Shuttler and Mesler<sup>17</sup> photographed bubbles that distorted into toroidal-shaped rings during collapse and produced ring-shaped indentations in a soft metal boundary. The bubbles rebounded following the initial collapse and caused pitting of the boundary. Pressures on the order of  $10^4$  atm have been estimated<sup>18</sup> during collapse of a bubble. All known materials can be damaged by exposure to bubble collapse for a sufficiently long time. This is properly called *cavitation erosion*, or *pitting*. Figure 20 shows extensive damage to the suction side of pump impeller vanes after about three months' operation with cavitation. At two locations, the pitting has penetrated deeply into the  $\frac{3}{8}$ -in (9.5-mm) thickness of stainless steel. The unfavorable inlet flow conditions, believed to have been the cause of the cavitation, were at least partly due to elbows in the approach piping. Modifications in the approach piping and the pump inlet passages reduced the cavitation enough to extend impeller life to several years.<sup>19</sup>

It has been postulated that high temperatures and chemical action may be present at bubble collapse, but any damaging effects due to them appear to be secondary to the mechanical action. It seems possible that erosion by foreign materials in the liquid and cavitation pitting may augment each other. Controlled experiments<sup>20</sup> with water indicated that the damage to metal depends on the liquid temperature and was a maximum at about 100 to 120°F (38 to 49°C). Cavitation pitting, as measured by weight of the boundary material removed per unit time, frequently increases with time. Cast iron and steel boundaries are particularly vulnerable. Controlled experiments have shown that cavitation pitting in metals such as aluminum, steel, and stainless steel depends strongly on the velocity of the fluid in the undisturbed flow past the boundary. On the basis of tests of short duration, Knapp<sup>15</sup> reported that damage to annealed aluminum increased approximately as the sixth power of the velocity of the undisturbed flow past the surface. Hammitt<sup>21</sup> found a more complicated relationship between velocity and damage, as shown in Figure 21. It seems clear that after cavitation begins, it will increase rapidly with increasing velocities. Frequently the rate of pitting accelerates with elapsed time. Comprehensive discussions of cavitation and erosion together with additional references are given by Preece.<sup>22</sup>

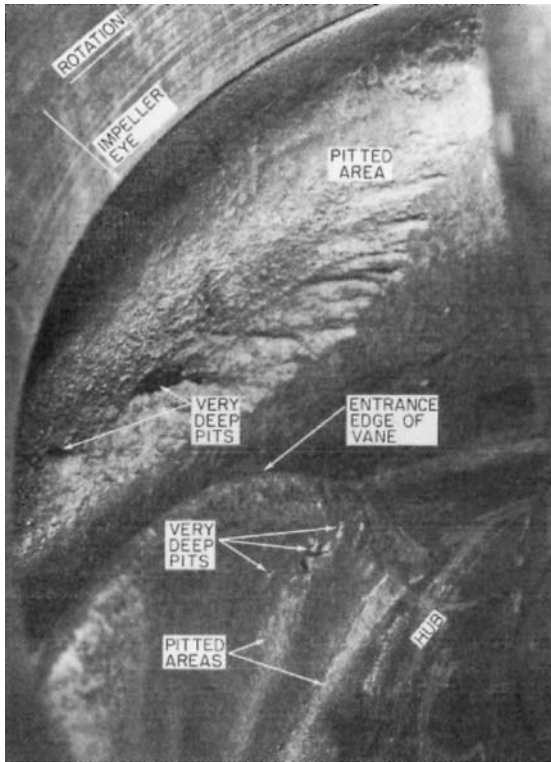


FIGURE 20 Impeller damaged by cavitation (Demag Delaval, Reference 19)

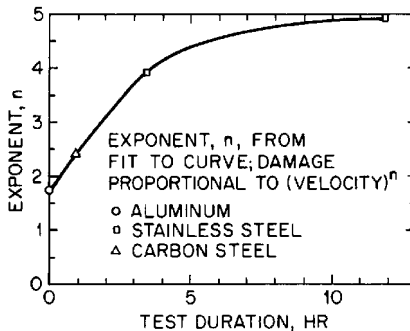


FIGURE 21 Cavitation damage exponent versus test time for several materials in water (Reference 21)

Centrifugal pumps begin to cavitate when the suction head is insufficient to maintain pressures above the vapor pressure throughout the flow passages. The most sensitive areas usually are the low-pressure sides of the impeller vanes near the inlet edge and the front shroud, where the curvature is greatest. Axial-flow and high-specific-speed impellers without front shrouds are especially sensitive to cavitation on the low-pressure

sides of the vane tips and in the close tip-clearance spaces. Sensitive areas in the pump casing include the low-pressure side of the tongue and the low-pressure sides of diffusion vanes near the inlet edges. As the suction head is reduced, all existing areas of cavitation tend to increase and additional areas may develop. Apart from the noise and vibration, cavitation damage may render an impeller useless in as little as a few weeks of continuous operation. In multistage pumps cavitation usually is limited to the first stage, but Kovats<sup>23</sup> has pointed out that second and higher stages may cavitate if the flow is reduced by lowering the suction head (submergence control). Cavitation tends to lower the axial thrust of an impeller. This could impair the balancing of multistage pumps with opposed impellers. A reduction in suction pressure may cause the flow past a balancing drum or disk to cavitate where the liquid discharges from the narrow clearance space. This may produce vibration and damage resulting from contact between fixed and running surfaces.

**Net Positive Suction Head (NPSH)** Several criteria exist for establishing the *NPSH* of a pump. These are connected with a) inception of cavitation, b) loss of hydraulic performance, and c) protecting the pump against cavitation erosion or damage. These are defined and found as follows:

- a. *Inception NPSH*. Cavitation can be completely prevented so long as the static pressure within the pump is everywhere greater than the vapor pressure of the liquid. This can be achieved if the *NPSH* (also called  $h_w$ ), defined in Section 2.1 as the total head of the pumped liquid at the pump inlet datum or suction flange above that vapor pressure, is sufficiently large. The value of *NPSH* that achieves this is called *NPSH<sub>i</sub>*, namely, the “inception *NPSH*.”
- b. *Performance NPSH*. In a typical *NPSH*-test at constant speed  $n$  and flow rate  $Q$ , a substantial reduction of *NPSH* below *NPSH<sub>i</sub>* is usually necessary to reach the value that produces an identifiable drop in performance—usually 3% of pump stage total pressure rise or pump head. This value is called the “required *NPSH*,” *NPSHR* or *NPSH<sub>3%</sub>*. Table 1 in Section 2.1 provides empirical correlations for *NPSH<sub>3%</sub>* for common pumps and inducers. Other criteria for *NPSH<sub>3%</sub>* will be given further on. The domains of cavitation within a pump are widespread at this condition, and experience shows that a head drop in the neighborhood of 3% must occur in order to obtain a repeatable value of *NPSHR* on test<sup>12</sup>. Lower percentages have been demanded by users, but they invariably give rise to a large scatter in the measured *NPSHR* for even small variations in any of the test variables.

It used to be thought throughout the pump community that there are no cavities or bubbles present at zero percent head drop due to cavitation activity within a pump. In recent decades, however, it has been proven through many observations that not only is the head drop equal to zero at inception (where  $NPSH = NPSH_i$ ), it remains so for an enormous range of lesser *NPSH*-values over which extensive bubble activity is observed. In fact, *NPSH<sub>i</sub>* is commonly from two to five times the magnitude of the *NPSHR* that is associated with any noticeable drop in pump head. At the 3% (or lesser percentage) head drop condition, actual observations of the cavitating flow show the cavities to extend all the way from the leading edge of each blade to the throat formed by the leading edge of the next blade<sup>24</sup>. In the face of these learnings, it is evident that to demand a test for the *NPSH* required for a head drop of much less than 3% usually causes only needless misunderstandings and expenditure of time and money.

- c. *Damage-Limiting NPSH or Life NPSH*. If it is desired to substantially reduce or eliminate cavitation activity within the pump, an acceptance test should be conducted wherein the cavitating flow can be observed visually<sup>25</sup>. This is indeed a serious issue if the pump energy level is high enough (and therefore the inlet pressure) for the collapsing cavities to do damage (as in Figure 20; see also Section 2.1). In such a case, “*NPSH<sub>3%</sub>*” has virtually no meaning; rather, the truly *required NPSH* or “*NPSHR*” is that *larger* value which satisfactorily limits the extent of this visually observed cavitation within the pump or pump model<sup>26</sup>.

Therefore, the *available NPSH* at the installation must be at least equal to the *required NPSH* if the above consequences are to be avoided—be they significant loss of

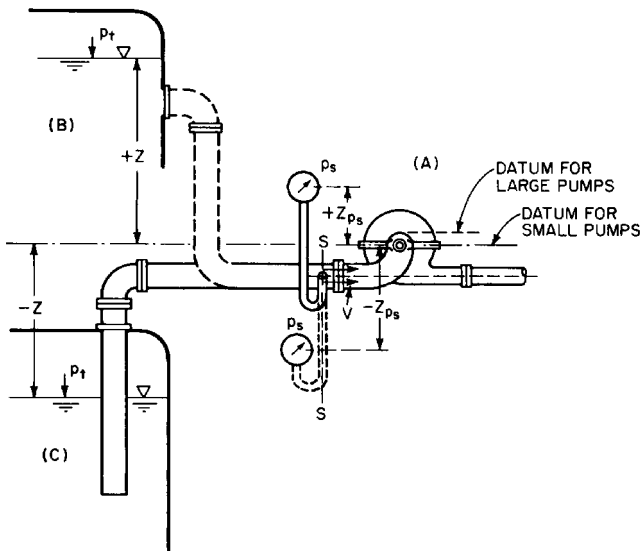


FIGURE 22 Definition sketch for computing NPSH

pump head (that is, loss of hydraulic performance) or damage due to collapsing cavities. Increasing the available *NPSH* above the required value provides a margin of safety against unpredictable variations of conditions, including transient behavior. Figure 22 and the following symbols will be used to compute the available *NPSH*:

$p_a$  = absolute pressure in atmosphere surrounding gage, Figure 22

$p_s$  = gage pressure indicated by gage or manometer connected to pump suction at section s-s; may be positive or negative

$p_t$  = absolute pressure on free surface of liquid in closed tank connected to pump suction

$p_{vp}$  = vapor pressure of liquid being pumped corresponding to the temperature at section s-s (if liquid is a mixture of hydrocarbons,  $p_{vp}$  must be measured by the *bubble point* method)

$h_f$  = lost head due to friction in suction line between tank and section s-s

$V$  = average velocity at section s-s

$Z, Z_{ps}$  = vertical distances defined by Figure 22; may be positive or negative

$\gamma$  = specific weight of liquid at pumping temperature

It is satisfactory to choose the datum for small pumps as shown in Figures 1 and 22, but with large pumps, the datum should be raised to the elevation where cavitation is most likely to start. For example, the datum for a large horizontal-shaft propeller pump should be taken at the highest elevation of the impeller-blade tips. The available *NPSH* is given by

$$h_{sv} = \frac{p_a - p_{vp}}{\gamma} + \frac{p_s}{\gamma} + Z_{ps} + \frac{V^2}{2g} \quad (15)$$

or

$$h_{sv} = \frac{p_t - p_{vp}}{\gamma} + Z - h_f \quad (16)$$

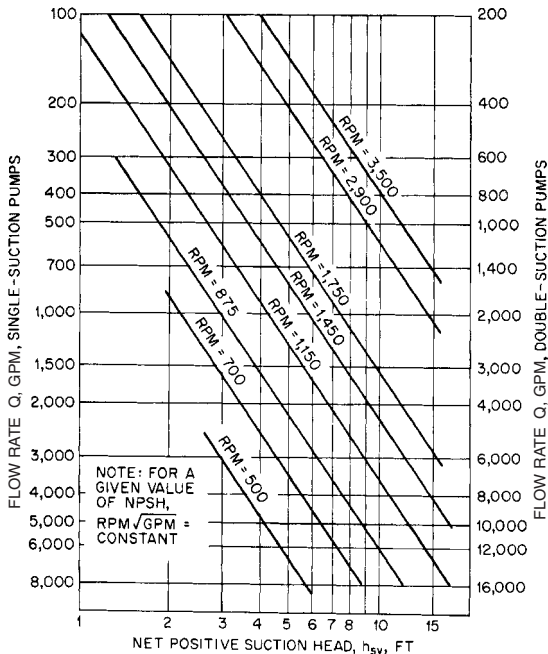
Consistent units must be chosen so that each term in Eqs. 15 and 16 represents feet (or meters) of the liquid pumped. Equation 15 is useful for evaluating the results of tests. Equation 16 is useful for estimating available  $NPSH$  during the design phase of an installation. In Eq. 15, the first term represents the height of a liquid barometer,  $h_b$ , containing the liquid being pumped and the sum of the remaining terms represents the suction head  $h_s$ ; that is, the total head  $H$  (Eq. 3, Section 2.1) evaluated at the suction flange  $S$  in Figure 22. Therefore

$$h_{sv} = h_b + h_s \quad (17)$$

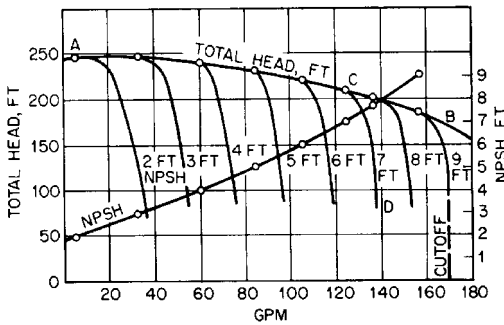
Usually, a positive value of  $h_s$  is called a *suction head* and a negative value of  $h_s$  is called a *suction lift*.

Many pumps draw cold water from reservoirs exposed to atmospheric pressure, so the suction lift is limited if there is to be a reasonable value of  $h_{sv}$  ( $= NPSH$ ) available at the pump suction flange or port. In normal practice, rather small values of suction lift or suction head are encountered in many installations, so one can depend on the value of  $h_{sv}$  being a substantial portion of  $h_b$ —say about 60% or 20 ft (6m) of water column. Recognizing that the suction specific speed capability  $S$  of most pumps falls within a rather small range has led to charts of recommended operating speeds such as those in Section 9.10 or the speed recommendations of Figure 23 for condensate pumps for varying amounts of  $NPSH$  available. In fact,  $S = 8500$  ( $\Omega_{ss} = 3.11$ ) is recommended by the Hydraulic Institute<sup>27</sup>.  $S$  ( $= N_{ss}$ ) and  $\Omega_{ss}$  are defined in Eqs. 41 and 42 of Section 2.1. The relationship of suction-specific speed to other suction parameters is treated further on.

**Cavitation Tests** In addition to the constant- $Q$  tests for  $NPSHR$  that were described in the foregoing review of the various  $NPSH$ -criteria, one can establish the curve of performance  $NPSH$  versus flow rate by varying the  $NPSH$  available and seeing how much flow



**FIGURE 23** Capacity (flow rate) and speed limitations for condensate pumps with shaft through eye of impeller ( $\text{ft} \times 0.3048 = \text{m}$ ;  $\text{gpm} \times 0.06309 = \text{l/s}$ ) (adapted from Hydraulic Institute ANSI/HI 2000 Edition Pump Standards, Reference 27)



**FIGURE 24** Test of a 1.5-in. (3.81-cm) single-stage pump at 3470 rpm, on water, 70°F (21°C) ( $\text{ft} \times 0.3048 = \text{m}$ ;  $\text{gpm} \times 0.06309 = \text{l/s}$ ) (Reference 12)

rate  $Q$  the pump can handle. This is illustrated in Figure 24, wherein a different head curve is found for each value of  $NPSH$ . For each such curve, as  $Q$  is increased, there is a point at which the head departs from the next one of higher  $NPSH$ . This, then, is the  $Q$  for which the given  $NPSH$  is that required to maintain head, essentially  $NPSH_{3\%}$ . At higher flow rate, performance is lost, each head curve possessing a “cutoff” flow rate. References 27 and 28 may be consulted for details of test procedures.

**Thoma Cavitation Parameter  $\sigma$**  All the terms in Eqs. 15 to 17 may be made dimensionless by dividing each by the pump head  $H$ . The resulting parameter

$$\sigma = \frac{h_{sv}}{H} \quad (18)$$

has proven to be useful especially for high-specific speed pumps and turbines. The loading on the blades of a variable-pitch propeller, and therefore the minimum suction-side static pressure, is directly connected to the head developed. As this head increases with increasing blade setting angle, the loading increases, the minimum pressure drops, and the  $NPSHR$  goes up. Hence an identifiable limiting value of  $\sigma$  is found to exist for such a machine.  $\sigma$ -limits are presented for a range of specific speeds in Figure 25.

Performance- $NPSH$  data are sometimes given in terms of  $\sigma$ ; for example, Rüttschi<sup>13</sup> presents the effect of pump hydraulic efficiency on  $NPSH$  in these terms, a consistently higher value of  $\sigma$  being required for pumps with lower efficiency (Figure 26).

**Suction-Specific Speed** For pumps in which the eye diameter of the impeller is smaller than that at exit, the pressures on the suction-sides of the blades that are associated with most of the head addition are in a region of higher pressure than in the vicinity of the eye. Thus Wislicenus<sup>29</sup> was able to decouple the eye from outer diameter of the pump (where most of the head is generated in a radial-flow machine) and show that only the eye geometry determines performance- $NPSH$  and not the magnitude of the head created by the impeller. He demonstrated that for most centrifugal pumps (except the propellers just described), there is a small range of suction specific speed—from which the performance- $NPSH$  can be determined. As in defined in Section 2.1, this parameter is defined as follows:

$$S = \frac{N\sqrt{Q}}{(h_{sv})^{3/4}} \quad (19)$$

Note that  $Q$  = half the discharge of a double-suction impeller when computing  $S$ . Equations 18 and 19 and the definition of  $n_s$  may be combined to yield

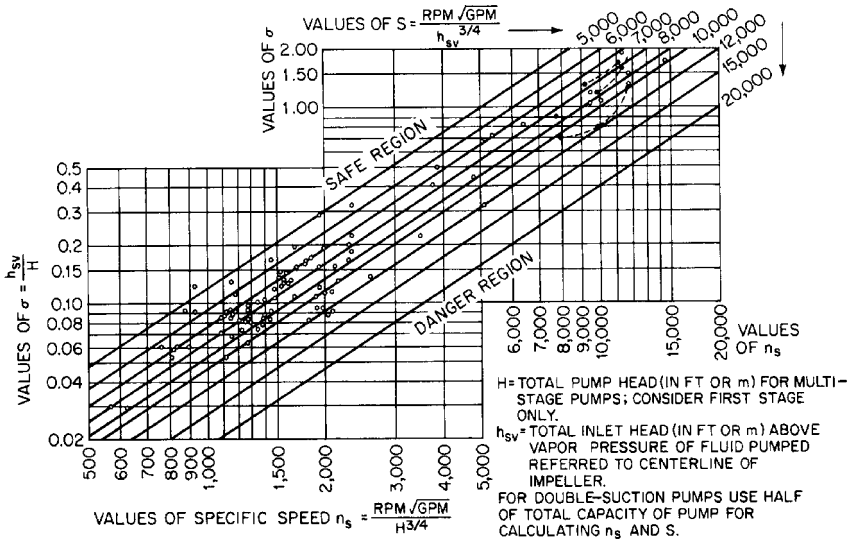


FIGURE 25 Cavitation limits of centrifugal and propeller pumps (Flowserve Corporation)

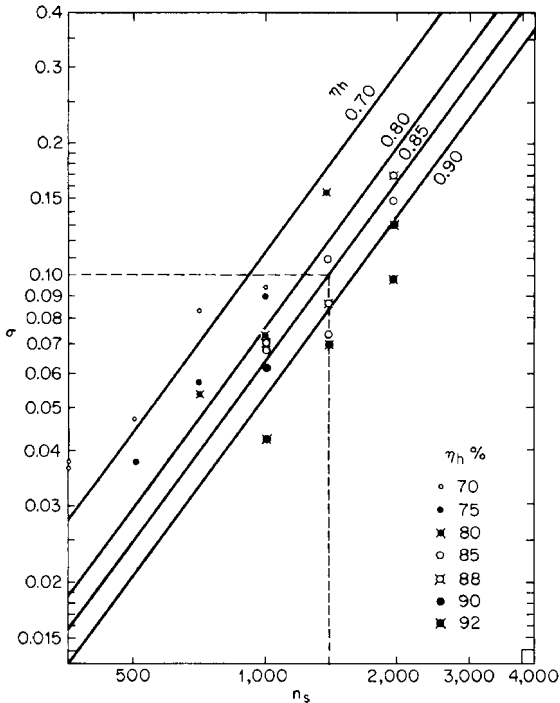
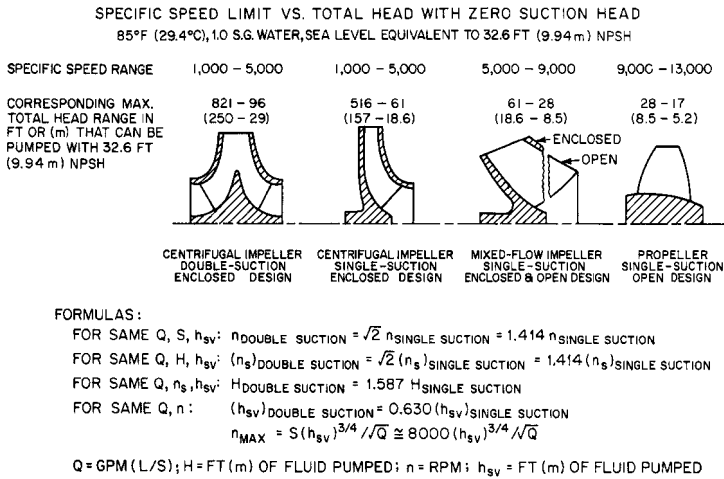


FIGURE 26 Cavitation parameter  $\sigma$  versus specific speed for different efficiencies ( $\Omega_s = n_s/2733$ ) (Reference 13)



**FIGURE 27** Commercial pumps applicable to zero suction head. Suction specific speed  $S = 8000$  ( $\Omega_{ss} = 2.93$ ). For centrifugal impellers,  $n_s = 1,000$ -5,000 ( $\Omega_s = 0.4$ -1.8); mixed-flow, 5,000-9,000 (1.8-3.3); propeller, 9,000-13,000 (1.3-4.8).

$$\sigma = \left( \frac{n_s}{S} \right)^{4/3} \quad (20)$$

$$n_s = S(\sigma)^{3/4} \quad (21)$$

Figure 25 shows lines of constant  $S$ . For most pumps,  $7500 < S < 11,000$  ( $2.7 < \Omega_{ss} < 4.0$ ),  $S = 8500$  (3.11) being recommended by the Hydraulic Institute ANSI/HI 2000 Pump Standards (Reference 27). Higher values may apply to special designs or service conditions, such as an inducer ahead of the first-stage impeller. For a given specific speed, the lower the value of  $S$ , the safer the pump against cavitation. Experience with large European pumped storage installations has shown that cavitation effects began at  $S \approx 6000$  (2.2), and this value is recommended for large pumps. Figure 27 shows a summary of data and formulas that may be useful with commercial pumps.

German practice differs considerably from that in the United States in computing suction specific speed. Pfleiderer<sup>1</sup> defined a hub correction  $k$  as

$$k = 1 - \left( \frac{d_h}{D_o} \right)^2 \quad (22)$$

where  $d_h$  = the hub diameter and  $D_o$  = the diameter of the suction nozzle, in any consistent units. The suction specific speed  $S_G$  is defined as

$$S_G = \frac{(n/100)^2 Q}{k h_{sv}^{3/2}} \quad (23)$$

where  $n$  is measured in rpm,  $Q$  in cubic meters per second per impeller inlet, and  $h_{sv}$  in meters of liquid pumped. It follows that

$$S = 5164 \sqrt{S_G k} \quad (24)$$

**NPSH for Liquids Other Than Cold Water** Field experience, together with carefully controlled laboratory experiments, has indicated that pumps handling hot water or cer-



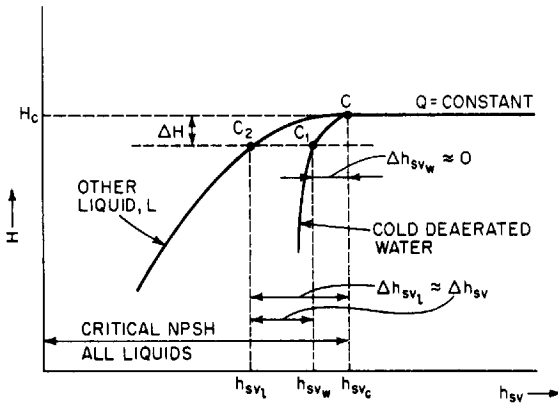
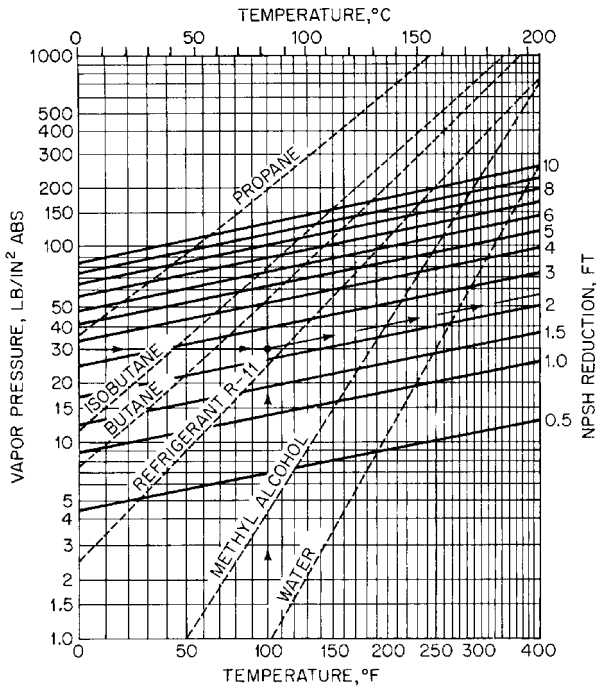


FIGURE 28 Cavitation tests with different liquids at constant speed and constant flow rate (Reference 34)

tain liquid hydrocarbons may be operated safely with less *NPSH* than would normally be required for cold water. This may lower the cost of an installation appreciably, particularly in the case of refinery pumps. A theory for this has been given by Stepanoff and others.<sup>14,30-33</sup> Figure 28 shows the results of cavitation tests on two liquids for constant capacity and constant pump speed. No head loss due to cavitation is present at point *C* or at  $h_{sv} > h_{svc}$ . With cold deaerated water, lowering  $h_{sv}$  slightly below  $h_{svc}$  produces limited cavitation and a decrease in pump head  $\Delta H$  to point  $C_1$ , but  $\Delta h_{sw}$  usually is negligible. With hot water ( $T \geq 100^\circ\text{F} = 37.8^\circ\text{C}$ ) or with many liquid hydrocarbons, a much larger decrease in  $h_{sv}$  will be required to produce the same drop in head  $\Delta H$  that was shown by the cold water test. The *NPSH reduction*, or *NPSH adjustment*, is  $\Delta H_{sv} \approx \Delta h_{svL}$ . In practice,  $\Delta H$  has been limited to  $\Delta h \leq 0.03H$ , for which there is a negligible sacrifice in performance. The pumps usually are made of stainless steel or other cavitation-resistant materials, and the lower *NPSH* results in lower collapse pressure of the vapor bubbles, reducing the damage potential.

**Chart for *NPSH* Reductions** A composite chart of *NPSH reductions* for deaerated hot water and certain gas-free liquid hydrocarbons is shown in Figure 29. The curves of vapor pressure versus temperature and the curves of constant *NPSH* reduction were based on laboratory tests with the liquids shown and should be used subject to the following limitations:

1. No *NPSH* reduction should exceed 50% of the *NPSH* required by the pump for cold water or 10 ft (3.0 m), whichever is smaller.
2. *NPSH* may have to be increased above the normal cold-water value to avoid unsatisfactory operation when (a) entrained air or other noncondensable gas is present in the liquid or (b) dissolved air or other noncondensable gas is present in the liquid and the absolute suction pressure is low enough to permit release of the gas from solution.
3. The vapor pressure of hydrocarbon mixtures vary significantly with temperature and so should be determined at pumping temperature (see Reference 27).
4. If the suction system may be susceptible to transient changes in absolute pressure or temperature, a suitable margin of safety in *NPSH* should be provided. This is particularly important with hot water and may exceed the reduction that would otherwise apply with steady-state conditions.
5. Although experience has indicated the reliability of Figure 29 for hot water and the liquid hydrocarbons shown, its use with other liquids is not recommended unless it is clearly understood that the results must be accepted on an experimental basis.



**FIGURE 29** *NPSH* reductions for pumps handling liquid hydrocarbons and hot water. This chart has been constructed from test data obtained by using the liquids shown. For applicability to other liquids, refer to the text ( $\text{ft} \times 0.3048 = \text{m}$ ;  $\text{lb}/\text{in}^2 \times 6.895 = \text{kPa}$ ). (Hydraulic Institute ANSI/HI 2000 Edition Pump Standards, Reference 27)

**USE OF FIGURE 29** Given a fluid having a vapor pressure of  $30 \text{ lb}/\text{in}^2$  ( $210 \text{ kPa}$ ) abs at  $100^\circ\text{F}$  ( $37.8^\circ\text{C}$ ). Follow the arrows on the key shown on the chart and obtain an *NPSH* reduction of about  $2.3 \text{ ft}$  ( $0.70 \text{ m}$ ). Since this does not correspond to one of the liquids for which vapor pressure curves are shown on the chart, the use of this *NPSH* reduction should be considered a tentative value only. Given a pump requiring  $16\text{-ft}$  ( $4.9\text{-m}$ ) cold-water *NPSH* at the operating capacity, the pump is to handle propane at  $55^\circ\text{F}$  ( $12.8^\circ\text{C}$ ). Figure 29 shows the vapor pressure to be about  $105 \text{ lb}/\text{in}^2$  ( $733 \text{ kPa}$ ) abs and the *NPSH* reduction to be about  $9.5 \text{ ft}$  ( $2.9 \text{ m}$ ). Since this exceeds  $8 \text{ ft}$  ( $2.44 \text{ m}$ ), which is half the cold-water *NPSH*, the recommended *NPSH* for the pump handling propane is half the cold-water *NPSH*, or  $8 \text{ ft}$  ( $2.44 \text{ m}$ ). If the temperature of the propane in the previous example is reduced to  $14^\circ\text{F}$  ( $-10^\circ\text{C}$ ), Figure 29 shows the vapor pressure to be  $50 \text{ lb}/\text{in}^2$  ( $349 \text{ kPa}$ ) abs and the *NPSH* reduction to be about  $5.7 \text{ ft}$  ( $1.74 \text{ m}$ ), which is less than half the coldwater *NPSH*. The *NPSH* required for pumping propane at  $14^\circ\text{F}$  ( $-10^\circ\text{C}$ ) is then  $16 - 5.7 = 10.3 \approx 10 \text{ ft}$  ( $4.87 - 1.74 = 3.13 \approx 3 \text{ m}$ ).

**Reduction of Cavitation Damage** After the pump has been built and installed\*, there is little that can be done to reduce cavitation damage. As previously mentioned, sharpening the leading edges of the blades by filing may be beneficial. Stepanoff<sup>22</sup> has suggested cutting back part of the blades in the impeller eye together with sharpening the tips, for low-specific-speed pumps, as a means of reducing the inlet velocity  $c_1$  and thus lowering  $\sigma$ . Although a small amount of prerotation or prewhirl in the direction of impeller rota-

\*Sometimes it is possible to lower the pump, and this should be considered before other alterations are made.

tion may be desirable<sup>34</sup>, excessive amounts should be avoided. This may require straightening vanes ahead of the impeller and rearranging the suction piping to avoid changes in direction or other obstructions. The cavitation damage to the impeller shown in Figure 20 was believed to have been at least partly due to bad flow conditions produced by two 90° elbows in the suction piping. The planes of the elbows were at 90° to each other, and this arrangement should be avoided.

Straightening vanes in the impeller inlet may increase the *NPSH* requirement at all flow rates. Three or four radial ribs equally spaced around the inlet and extending inward about one-quarter of the inlet diameter are effective against excessive prerotation and may require less *NPSH* than full-length vanes. This is very important with axial-flow pumps, which are apt to have unfavorable cavitation characteristics at partial flow rates. Operation near the best efficiency point usually minimizes cavitation.

The admission of a small amount of air into the pump suction tends to reduce cavitation noise.<sup>7</sup> This rarely is done, however, because it is difficult to inject the right amount of air under varying head and flow rate conditions and frequently there are objections to mixing air with the liquid pumped.

If a new impeller is required because of cavitation, the design should take into account the most recent advances described in the literature. Gongwer<sup>35</sup> has suggested (1) the use of ample fillets where the vanes join the shrouds, (2) sharpened leading edges of vanes, (3) reduction of  $\beta$ , in the immediate vicinity of the shrouds, and (4) raking the leading edges of the vanes forward out of the eye. Increasing the number of vanes for propeller pumps lowers  $\sigma$  for a given submergence. A change in the impeller material may be very beneficial, as described below.

**Resistance of Materials to Cavitation Damage** Table 8 shows the relative resistance of several metals to cavitation pitting produced by magnetostriction vibration. It will be seen that cast iron, the most commonly used material for impellers, has relatively little pitting resistance relative to bronze and stainless steel, which are readily cast and finished.

Damage due to cavitation erosion is commonly assessed in terms of the depth of penetration. The life of an impeller is generally considered to be the time required for cavitation erosion to reach a depth of 75% of the blade thickness at any point<sup>36</sup>. The life of any material in years can be expressed as the product of the mean depth of penetration rate

**TABLE 8** Cavitation erosion resistance of metals

Alloy	Magnetostriction weight loss after 2 h, mg
Rolled stellite <sup>a</sup>	0.6
Welded aluminum bronze	3.2
Cast aluminum bronze	5.8
Welded stainless steel (2 layers, 17 Cr-7 Ni)	6.0
Hot rolled stainless steel (26 Cr-13 Ni)	8.0
Tempered rolled stainless steel (12 Cr)	9.0
Cast stainless steel (18 Cr-8 Ni)	13.0
Cast stainless steel (12 Cr)	20.0
Cast manganese bronze	80.0
Welded mild steel	97.0
Plate steel	98.0
Cast steel	105.0
Aluminum	124.0
Brass	156.0
Cast iron	224.0

<sup>a</sup>Despite the high resistance of this material to cavitation damage, it is not suitable for ordinary use because of its comparatively high cost and the difficulty encountered in machining and grinding.

Source: Reference 69.

(*MDPR*, in mm per year) times the thickness of the material in mm. Values of *MDPR* have been deduced<sup>37</sup> from the weight loss of test samples of known diameter in a magnetostrictive test (Table 8)<sup>38</sup>. Unfortunately, *MDPR*-values obtained in such tests are not the same as those of actual pumps, as the mode of cavitation varies with pump operating conditions and is generally different from the laboratory results. Nevertheless, laboratory results for *MDPR* have been used to rank the ability of various materials to resist cavitation erosion in pumps. See Section 5.1 for material selection guidelines.

Cavitation-resistant coatings, either metallic or nonmetallic, have found some niche applications. Elastomeric coatings are resilient and resist cavitation through a different erosion mechanism than that of metal. As such, they can be very effective<sup>69</sup>. At least two considerations are involved in the use of coatings for resisting cavitation damage: 1) even if a contemplated coating demonstrates a reduced damage or erosion rate, this reduction must be enough to justify the cost of establishing a satisfactory bond between the coating and the base metal; 2) erosion of both the coating and the base material must be considered in determining the life according to the above 75%-depth criterion. Therefore, the life in this case would be equal to the *MDPR* of the coating times the coating thickness plus the *MDPR* of the base material times the allowable erosion depth of that material.

**Inducers** It is sometimes difficult or impossible to provide the required *NPSH* for an otherwise acceptable pump. Besides normal industrial situations that might produce a very low available *NPSH*, the need to keep the weight down in aircraft and rocket liquid-propellant pumps has led to high rotative speeds, which, for typical values of *NPSH*, produce extremely high suction specific speeds. The performance-*NPSH* required by the impeller under these circumstances can be provided by a small, axial-flow booster pump, called an inducer, placed ahead of the first-stage impeller<sup>39</sup>. Inducers are designed to operate with very low *NPSH* and to provide enough head to satisfy the *NPSH* required by the impeller. In fact, long stable cavities are established on the suction sides of the long, lightly-loaded blades of an inducer, which enable it to operate at about twice the suction specific speed of a conventional impeller<sup>40,41</sup>. At lower than normal flow rates, however, inducers readily produce swirling, destabilizing backflow at the inlet, which can cause excessive pump vibration in high-head pumps. These instabilities can be overcome by various passive design features, such as that described in Reference 39.

The inducers described in Reference 42 (Figure 30) have “constant lead” helical blades. They contribute not more than 5% of the total pump head. Although the efficiency of the inducer alone is low, the reduction in overall pump efficiency is not significant. Because this type of inducer causes prerotation, a careful match between inducer and suction impeller is required. In vertical multistage pumps, where a long shaft can be better supported, a vane diffuser may be inserted between the inducer and the first-stage impeller. Such an arrangement is very beneficial for operation at reduced flow rate. Reference 42 shows that a suitable inducer-impeller combination can operate at about 50% of the *NPSH* required for the impeller alone at flow rates not exceeding the normal value. The *NPSH* requirement increases rapidly for flow rates above normal. Unless a variable-lead inducer is used<sup>32,39</sup>, operation in this range should be avoided.

**Entrained Air** Air or other gases may enter the impeller inlet from several sources. The immediate effect usually will be a drop in pump pressure rise, flow rate, and power. This will be followed by loss of prime if more gas is present than the impeller can handle. A typical limit for commercial industrial pumps is an inlet gas-to-liquid volume fraction (GVF) of 0.03, although specialty pumps such as those used in aircraft (Section 9.19) can handle higher GVF. See also Reference 9, Section 2.1. Air may be released from solution or enter through leaks in the suction piping. Stuffing box air leakage may be prevented by lantern rings supplied with liquid from the pump discharge. If the pump takes water from a sump with a free surface, a vortex may form from the free surface to the impeller inlet. The remedy may be the introduction of one or more baffle plates or even major changes in the sump. For information on proper sump design and the prevention of air-entraining vortices, see Sections 10.1 and 10.2, pp. 457 and 460 of Reference 7, and Reference 43. It is sometimes permissible to inject a small amount of air into the pump

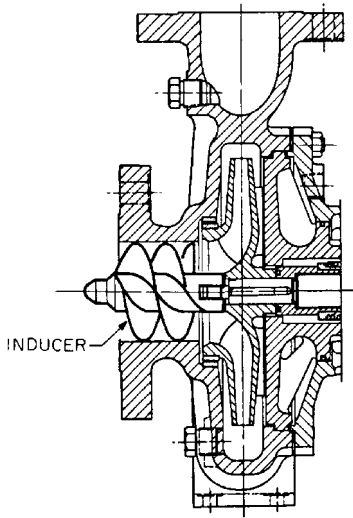


FIGURE 30 Pump fitted with inducer (Reference 42)

suction to reduce the noise and damage from cavitation caused by inadequate *NPSH* or recirculation in the impeller (see Subsection 2.3.2).

### STARTING CENTRIFUGAL PUMPS

**Priming** Centrifugal pumps usually are completely filled with the liquid to be pumped *before starting*. When so filled with liquid, the pump is said to be *primed*. Pumps have been developed to start with air in the casing and then be primed.<sup>44</sup> This procedure is unusual with low-specific-speed pumps but is sometimes done with propeller pumps<sup>12</sup>. In many installations, the pump is at a lower elevation than the supply and remains primed at all times. This is customary for pumps of high specific speed and all pumps requiring a positive suction head to avoid cavitation.

Pumps operated with a suction lift may be primed in any of several ways. A relatively inexpensive method is to install a special type of check valve, called a *foot valve*, on the inlet end of the suction pipe and prime the pump by filling the system with liquid from any available source. Foot valves cause undesirable frictional loss and may leak enough to require priming before each starting of the pump. A better method is to close a valve in the discharge line and prime by evacuating air from the highest point of the pump casing. Many types of vacuum pumps are available for this service. A priming chamber is a tank that holds enough liquid to keep the pump submerged until pumping action can be initiated. Self-priming pumps usually incorporate some form of priming chamber in the pump casing. Section 2.4 and Reference 7 may be consulted for further details.

**Torque Characteristics of Drivers** Centrifugal pumps of all specific speeds usually have such low starting torques (turning moments) that an analysis of the starting phase of operation seldom is required. Steam and gas turbines have high starting torques, so no special starting procedures are necessary when they are used to drive pumps. If a pump is directly connected to an internal combustion engine, the starting motor of the engine should be made adequate to start both driver and pump. If the starter does not have enough torque to handle both units, a clutch must be provided to uncouple the pump until the driver is started.

Electric motors are the most commonly used drivers for centrifugal pumps. Direct current motors and alternating current induction motors usually have ample starting torque for all pump installations, provided the power supply is adequate. Many types of reduced voltage starters are available<sup>7</sup> to limit the inrush current to safe values for a given power supply. Synchronous motors are often used with large pumps because of their favorable power-factor properties. They are started as induction motors and run as such up to about 95% of synchronous speed. At this point, dc field excitation is applied and the maximum torque the motor can then develop is called the pull-in *torque*, which must be enough to accelerate the motor and connected inertia load to synchronous speed in about 0.2 s if synchronous operation is to be achieved. Centrifugal pumps usually require maximum torque at the normal operating point, and this should be considered in selecting a driver, particularly a synchronous motor, to be sure that the available pull-in torque will bring the unit to synchronous speed.

**Torque Requirements of Pumps** The *torque*, or turning moment, for a pump may be estimated from the power curve in USCS units by

$$M = \frac{5252P}{n} \quad (25)$$

and in SI units by

$$M = \frac{9549P}{n}$$

where  $M$  = pump torque, lb · ft (N · m)

$P$  = power, hp (kW)

$n$  = speed, rpm

Equation 25 makes no allowance for accelerating the rotating elements or the liquid in the pump. If a 10% allowance for accelerating torque is included, the constant should be correspondingly increased. The time  $\Delta t$  required to change the pump speed by an amount  $\Delta n = n_2 - n_1$  is given by

$$\Delta t = \frac{I \Delta n}{k(M_m - M)} \quad (26)$$

where  $\Delta t$  = time, s

$I$  = moment of inertia (flywheel effect) of all rotating elements of driver, pump, and liquid, lb · ft (kg · m<sup>2</sup>)

$\Delta n$  = change in speed, rpm

$k$  = 307 in USCS (9.549 in SI)

$M_m$  = driver torque, lb · ft (N · m)

$M$  = pump torque, lb · ft (N · m) (Eq. 25)

The inertia  $I$  of the driver and pump usually can be obtained from the manufacturers of the equipment. The largest permissible  $\Delta n$  for accurate calculation will depend on how rapidly  $M_m$  and  $M$  vary with speed. The quantity  $M_m - M$  should be nearly constant over the interval  $\Delta n$  if an accurate estimate of  $\Delta t$  is to be obtained. Torque-speed characteristics of electric motors may be obtained from the manufacturers.

Horizontal-shaft pumps fitted with plain bearings and packed glands require a *breakaway torque* of about 15% of  $M_n$ , the torque at the normal operating point, to overcome the static friction. This may be reduced to about 10% of  $M_n$  if the pump is fitted with antifriction bearings. The breakaway torque may be assumed to decrease linearly with speed to nearly zero when the speed reaches 15 to 20% of normal. Construction of torque-speed curves requires a knowledge of the pump characteristics at normal speed as well as details of the entire pumping system. Some typical examples taken from Reference 7 are given

below. The following forms of the affinity laws (Eqs. 12) are useful in constructing the various performance curves:

$$Q_2 = Q_1 \frac{n_2}{n_1} \quad (27)$$

$$H_2 = H_1 \left( \frac{n_2}{n_1} \right)^2 = H_1 \left( \frac{Q_2}{Q_1} \right)^2 \quad (28)$$

$$P_2 = P_1 \left( \frac{n_2}{n_1} \right)^3 \quad (29)$$

$$M_2 = M_1 \left( \frac{n_2}{n_1} \right)^2 \quad (30)$$

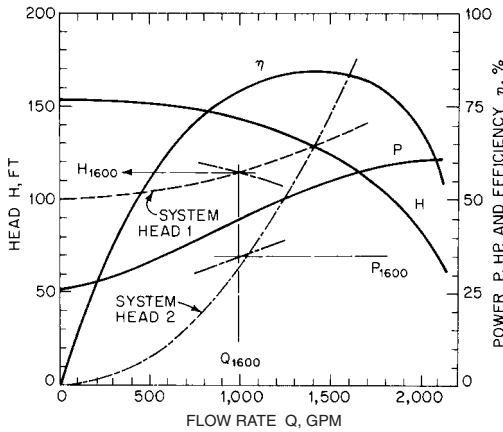
where  $Q$  = flow rate  
 $n$  = speed  
 $H$  = head  
 $P$  = power  
 $M$  = torque

in any consistent units of measure. After speeds  $n_1$  and  $n_2$  are chosen, the subscripts 1 and 2 refer to corresponding points on the characteristic curves for these speeds.

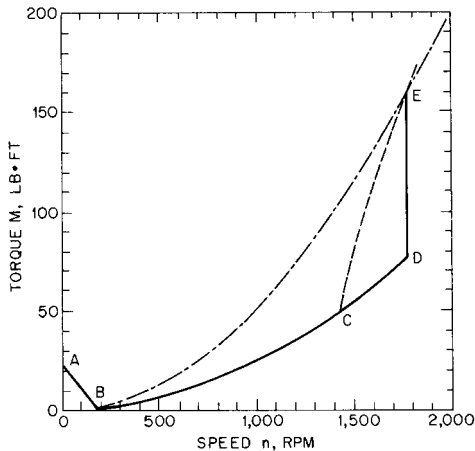
**Low-Specific-Speed Pumps** Figure 31 shows the constant-speed characteristics of a pump having  $n_s \approx 1740$  (0.64) at best efficiency. This pump usually would be started with a valve in the discharge line closed. During the starting phase, the pump operates at shut-off with  $P_1 = 25.8$  hp (19.2 kW) and  $n_1 = 1770$  rpm. Then, by Eq. 25,  $M_1 = 76.6$  lb · ft (103.9  $N \cdot m$ ). These values may be used in Eq. 30 to evaluate starting torques  $M_2$  at as many speeds  $n_2$  as desired and plotted in Figure 32 as curve *BCD*. Section *AB* of the starting torque curve is an estimate of the breakaway torque. If the discharge valve is now opened, the speed remains nearly constant but the torque increases as the capacity and power increase. If the normal operating point is  $Q = 1400$  gpm (88.3 l/s) and  $P_n = 53.2$  hp (39.7 kW), the motor torque will be  $M_n = 158$  lb · ft (214  $N \cdot m$ ) by Eq. 25. The vertical line *DE* in Figure 32 shows the change in torque produced by opening the discharge valve.

Instead of starting the pump with the discharge valve closed, let the pump be started with a check valve in the discharge line held closed by a static head of 100 ft (30.5 m). The frictional head in the system may be represented by  $kQ^2$ . The value of  $k$  may be estimated from the geometry of the system or from a frictional-loss measurement at any convenient flowrate  $Q$ , preferably near the normal capacity  $Q_n$ . In this example,  $Q_n = 1400$  gpm (88.33 l/s) and  $k = 14.4/10^6$  (0.00109). The curve labeled system head 1 in Figure 31 was computed from  $H = 100 + (14.4/10^6)Q^2$  ft ( $H = 30.48 + 0.00109Q^2$  m) and intersects the head curve at  $H = 128$  ft (39.01 m) and  $Q_n = 1400$  gpm (88.33 l/s). The normal shutoff head is  $H_1 = 153$  ft (46.6 m) at  $n_1 = 1770$  rpm. By Eq. 28, the pump will develop a shutoff head  $H_2 = 100$  ft (30.5 m) at  $n_2 = 1430$  rpm. By Eq. 30, the torque at 1430 rpm will be 50 lb · ft (68  $N \cdot m$ ), corresponding to point *C* in Figure 32. The portion *ABC* of the starting torque curve has already been constructed. Trial-and-error methods must be used to obtain the portion *ABC* of the starting torque curve.

The auxiliary curves in Figure 33 are useful in constructing the *CE* portion of the starting torque curve. Select a value of  $n_2$  intermediate between 1427 and 1770 rpm, say  $n_2 = 1600$  rpm. In Figure 31, read values of  $Q_1$ ,  $H_1$ , and  $P_1$  for speed  $n_1 = 1770$  rpm. By Eqs. 27 and 28, determine values of  $Q_2$  and  $H_2$  and plot as shown in Figure 31 until an intersection with the system-head 1 curve is obtained that provides  $Q_{1600}$  corresponding to  $n = 1600$  rpm. By Eq. 29, determine value of  $P_2$  and plot as shown in Figure 31 until an intersection is obtained with the  $Q_{1600}$  line which provides  $P_{1600}$  corresponding to  $n = 1600$  rpm. Eq. 34 is now used to obtain  $M_{1600}$ , which is one point on the desired starting torque curve. The process is repeated for various speeds  $n_2$  until the curve *CE* in Figure 32 can be drawn. The



**FIGURE 31** Characteristics of a 6-by-8 double-section pump at 1770 rpm ( $\text{ft} \times 0.3048 = \text{m}$ ;  $\text{gpm} \times 0.06309 = \text{l/s}$ ;  $\text{hp} \times 0.7457 = \text{kW}$   $n_s = 1,740$  ( $\Omega_s = 0.64$ ) (Reference 7)



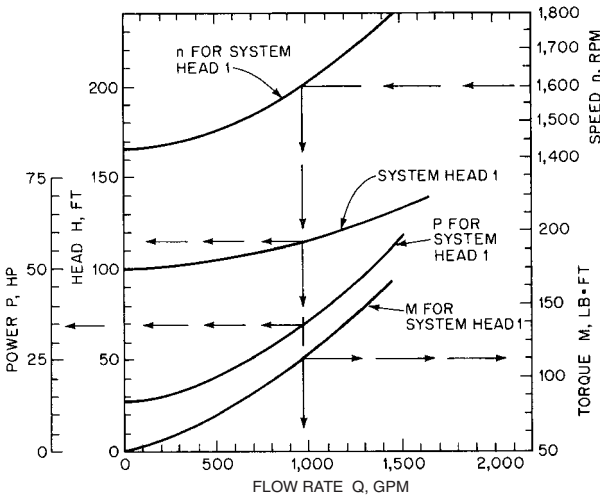
**FIGURE 32** Torque characteristics of 6-by-8 pump shown in Figure 31 ( $\text{lb} \cdot \text{ft} \times 1.356 = \text{N} \cdot \text{m}$ ) (Reference 7)

complete starting torque curve for this example is  $ABCE$  in Figure 31, with steady-state operation at point  $E$ .

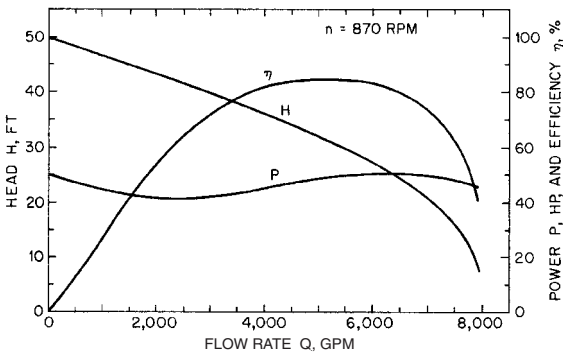
Assume that the pump of the preceding examples is installed in a system having zero static head but a long pipeline with friction head given by  $H = (65.4/10^6)Q^2$  ft ( $H = 0.00500Q^2$  m), as shown in Figure 31 by the curve labeled system head 2. The valve in the discharge line is assumed to open instantaneously when power is first applied to the pump. The procedure described to construct curve  $CE$  of the preceding example must now be used together with the system-head 2 curve of Figure 31 to obtain the curve  $BE$  of Figure 32. The complete starting torque curve for this example is  $ABE$  in Figure 32, with steady-state operation at point  $E$ .

The inertia of the fluid in the system was neglected in solving the previous examples. Some of the power must be used to accelerate the liquid, and this may be appreciable in the case of a long pipeline. Low-specific speed pumps, which are used with long pipelines, have





**FIGURE 33** Analysis of 6-by-8 pump shown in Figure 41 ( $\text{ft} \times 0.3048 = \text{m}$ ;  $\text{gpm} \times 0.06309 = \text{l/s}$ ;  $\text{lb} \cdot \text{ft} \times 1.356 = \text{N} \cdot \text{m}$ ;  $\text{hp} \times 0.7457 = \text{kW}$ ) (Reference 7)



**FIGURE 34** Characteristics of a 16-in (40.6cm) volute pump with mixed-flow impeller with flat power characteristic ( $\text{ft} \times 0.3048 = \text{m}$ ;  $\text{gpm} \times 0.06309 = \text{l/s}$ ;  $\text{hp} \times 0.7457 = \text{kW}$ ).  $n_s = 4570$  ( $\Omega_s = 1.672$ ) (Reference 7)

rising power curves with minimum power at shutoff and maximum power at normal flow rate. Experience has shown that the starting torque-speed curves computed by neglecting the inertia of the liquid are conservative, so inertia effects need not be included. The inertia effect of the liquid does slow the starting operation. If the time required to reach any event, such as a particular speed or flow rate, is required, the inertia of the liquid should be considered, but including it greatly increases the difficulty of computation. References 45 through 48 give general methods for handling problems involving liquid transients.

High-specific-speed pumps have falling power flow rate curves with maximum power at shutoff and minimum power at normal flow rate. Neglecting the inertia of the liquid probably will result in too low a value for the computed starting torque for such pumps. If liquid inertia is to be included, consult References 44 to 47 and Section 8.1.

**MEDIUM- AND HIGH-SPECIFIC-SPEED PUMPS** Figure 34 shows constant-speed characteristics for a medium-specific-speed pump,  $n_s = 4570$  (1.672) at best efficiency. The shutoff power

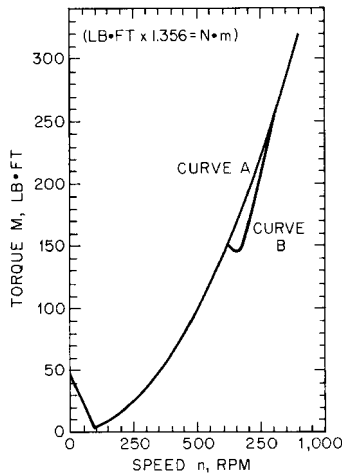


FIGURE 35 Torque characteristics of pump shown in Figure 34 (Reference 7)

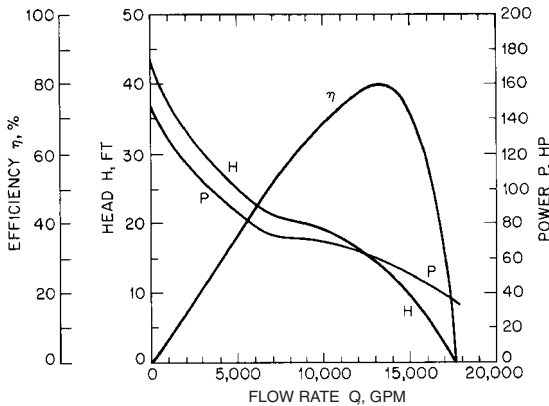


FIGURE 36 Characteristics of a 30-in (76.2-cm) discharge propeller pump at 700 rpm ( $\text{ft} \times 0.1048 = \text{m}$ ;  $\text{gpm} \times 0.06309 = \text{l/s}$ ;  $\text{hp} \times 0.7457 = \text{kW}$ ).  $n_s = 12,000$  ( $\Omega_s = 4.391$ ) (Reference 7)

is the same as the power at best efficiency, and the starting torque-speed curve is but little affected by the method of starting, as shown by Figure 35.

Figure 36 shows the constant-speed characteristics of a high-specific-speed propeller pump,  $n_s \approx 12,000$  (4.391) at best efficiency. Figure 37 shows the starting torque-speed curve when the pump is started against a static head of 14 ft (4.3 m) and a friction head of 1 ft (0.3 m) at  $Q_n = 12,500$  gpm (789 l/s). The system was assumed full of water with a closed check valve at the outlet end of the short discharge pipe. The methods of computation for Figures 35 and 37 were the same as for Figure 32.

Sometimes propeller pumps are started with the pump submerged but with the discharge column filled with air. In such a case, the torque-time characteristic for the driver must be known and a step-by-step calculation carried out. If the discharge column is a siphon initially filled with air, the starting torque may exceed the normal running torque during some short period of the starting operation. If the pump is driven by a synchronous

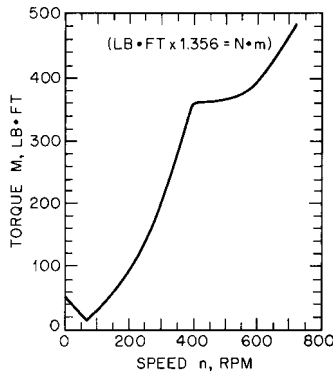


FIGURE 37 Torque characteristics of pump shown in Figure 36 (Reference 7)

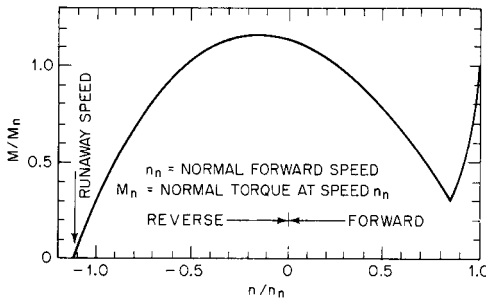
motor, it is particularly important to investigate the starting torque in the range of 90 to 100% of normal speed to make sure that the pull-in torque of the motor is not exceeded. For additional information regarding starting high-specific-speed pumps discharging through long and large diameter systems, see Section 8.1.

**Miscellaneous Requirements** Pumps handling hot liquids should be warmed up to operating temperature before being started unless they have been especially designed for quick starting. Failure to do this may cause serious damage to wearing rings, seals, and any hydraulic balancing device that may be present. A careful check of the installation should be made before starting new pumps, pumps that have had a major overhaul, or pumps that have been standing idle for a long time. It is very important to follow the manufacturer's instructions when starting boiler-feed pumps. If these are unavailable, Reference 7 may be consulted. Ascertain that the shaft is not frozen, that the direction of rotation is correct, preferably with the coupling disengaged, and that bearing lubrication and gland cooling water meet normal requirements. Failure to do this may result in damage to the pump or driver.

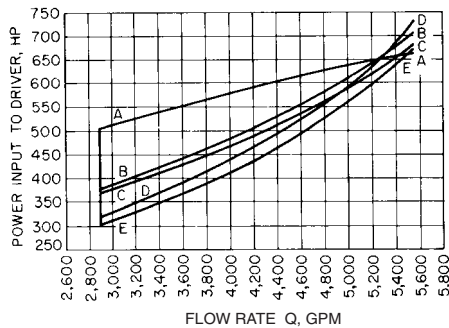
A pump may run backwards at runaway speed if the discharge valve fails to close following shutdown. Any attempt to start the pump from this condition will put a prolonged overload on the motor. Figure 38 shows one example of the torque-speed transient for a pump,  $n_s = 1700$  (0.622), started from a runaway reversed speed while normal pump head was maintained between the section and discharge flanges. In most practical cases, water hammer effects would make this transient even more unfavorable than Figure 38 indicates. The duration of such a transient will always be much longer than the normal starting time, and so protective devices would probably disconnect the motor from the power supply before normal operation could be achieved. Consult Section 8.1 for additional information on this subject.

## REGULATION OF FLOW RATE

Flow rate variation ordinarily is accomplished by a change in pump head, speed, or both simultaneously. The flow rate and power input of pumps with specific speeds up to about 4000 (1.464) double suction increase with decreasing head, so the drivers of such pumps may be overloaded if the head falls below a safe minimum value. Increasing the head of high-specific-speed pumps decreases the flow rate but increases the power input. The drivers of these pumps should either be able to meet possible load increases or be equipped with suitable overload protection. Flow rate regulation by the various methods given below may be manual or automatic (see also References 1, 7, 12, 34 and 49).



**FIGURE 38** Torque characteristics of a double-suction pump,  $n_s \approx 1700$  (0.64), from reversed runaway speed to normal forward speed (Reference 7)



**FIGURE 39** Power requirements of two double-suction pumps in series operated at constant head and variable flow rate. Total  $H_n = 382$  ft (116 m) for both pumps at 1800 rpm ( $\text{gpm} \times 0.06309 = \text{l/s hp} \times 0.7457 = \text{kW}$ ) (Reference 50). Curve AA: constant speed with discharge throttling. Curve BB: synchronous motor with variable-speed hydraulic coupling on each pump. Curve CC: variable-speed wound-rotor induction motor. Curve DD: dc motor with rectifier and shunt field control. Curve EE: synchronous motor with variable-speed constant-efficiency mechanical speed reducer

**Discharge Throttling** This is the cheapest and most common method of flow rate modulation for low- and medium-specific-speed pumps. Usually its use is restricted to such pumps. Partial closure of any type of valve in the discharge line will increase the system head so the system-head curve will intersect the pump head curve at a smaller flow rate, as shown in Figure 40. Discharge throttling moves the operating point to one of lower efficiency, and power is lost at the throttle valve. This may be important in large installations, where more costly methods of modulation may be economically attractive. Throttling to the point of cutoff may cause excessive heating of the liquid in the pump. This may require a bypass to maintain the necessary minimum flow or use of different method of modulation. This is particularly important with pumps handling hot water or volatile liquids, as previously mentioned. Refer to Section 8.2 for information regarding the sizing of a pump bypass.

**Suction Throttling** If sufficient *NPSH* is available, some power can be saved by throttling in the suction line. Jet engine fuel pumps frequently are suction throttled<sup>9</sup> because discharge throttling may cause overheating and vaporization of the liquid. At very low flow rate, the impellers of these pumps are only partly filled with liquid, so the power input and temperature rise are about one-third the values for impellers running full with discharge throttling. The capacity of condensate pumps frequently is submergence-controlled,<sup>7</sup> which

is equivalent to suction throttling. Special design reduces cavitation damage of these pumps to a negligible amount, the energy level (Section 2.1) being quite low.

**Bypass Regulation** All or part of the pump flow may be diverted from the discharge line to the pump suction or other suitable point through a bypass line. The bypass may contain one or more metering orifices and suitable control valves. Metered bypasses are commonly used with boiler-feed pumps for reduced-flow operation, mainly to prevent overheating. There is a considerable power saving if excess capacity of propeller pumps is bypassed instead of using discharge throttling.

**Speed Regulation** This can be used to minimize power requirements and eliminate overheating during flow rate modulation. Steam turbines and internal combustion engines are readily adaptable to speed regulation at small extra cost. A wide variety of variable-speed mechanical, magnetic, and hydraulic drives are available, as well as both ac and dc variable-speed motors. Usually variable-speed motors are so expensive that they can be justified only by an economic study of a particular case. Figure 39 shows a study by Richardson<sup>50</sup> of power requirements with various drivers wherein substantial economies in power may be obtained from variable-speed drives.

**Regulation by Adjustable Vanes** Adjustable guide vanes ahead of the impeller have been investigated and found effective with a pump of specific speed  $n_s = 5700$  (2.086). The vanes produced a positive prewhirl that reduced the head, flow rate, and efficiency. Relatively little regulation was obtained from the vanes with pumps having  $n_s = 3920$  (1.204) and 1060 (0.39). Adjustable outlet diffusion vanes have been used with good success on several large European storage pumps for hydroelectric developments. Propeller pumps with adjustable-pitch blades have been investigated with good success. Wide flow rate variation was obtained at constant head and with relatively little loss in efficiency. These methods are so complicated and expensive that they have very limited application in practice. Reference 34 may be consulted for further discussion and bibliography.

**Air Admission** Admitting air into the pump suction has been demonstrated as a means of flow-rate regulation, with some savings in power over discharge throttling. Usually air in the pumped liquid is undesirable, and there is always the danger that too much air will cause the pump to lose its prime. The method has rarely been used in practice but might be applicable to isolated cases.

## PARALLEL AND SERIES OPERATION

---

Two or more pumps may be arranged for parallel or series operation to meet a wide range of requirements in the most economical manner. If the pumps are close together, that is, in the same station, the analysis given below should be adequate to secure satisfactory operation. If the pumps are widely separated, as in the case of two or more pumps at widely spaced intervals along a pipeline, serious pressure transients may be generated by improper starting or stopping procedures. The analysis of such cases may be quite complicated, and References 46 to 48 should be consulted for methods of solution.

**Parallel Operation** Parallel operation of two or more pumps is a common method of meeting variable-flow-rate requirements. By starting only those pumps needed to meet the demand, operation near maximum efficiency can usually be obtained. The head-flow characteristics of the pumps need not be identical, but pumps with unstable characteristics may give trouble unless operation only on the steep portion of the characteristic can be assured. Care should be taken to see that no one pump, when combined with pumps of different characteristics, is forced to operate at flows less than the minimum required to prevent recirculation. See the discussion that follows on operation at other than normal flow rate. Multiple pumps in a station provide spares for emergency service and for the downtime needed for maintenance and repair.

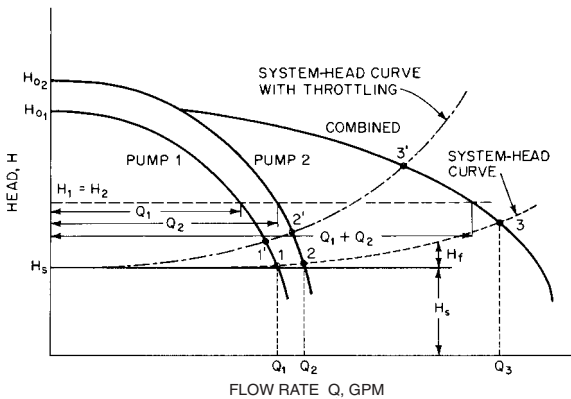


FIGURE 40 Head-flow curves of pumps operating in parallel

The possibility of driving two pumps from a single motor should always be considered, as it usually is possible to drive the smaller pumps at about 40% higher speed than a single pump of twice the capacity. The saving in cost of the higher-speed motor may largely offset the increased cost of two pumps and give additional flexibility of operation.

One of the first steps in planning for multiple-pump operation is to draw the system-head curve, as shown in Figure 40. The system head consists of the static head  $H_s$  and the sum  $H_f$  of the pipe-friction head and the head lost in the valves and fittings (see Sections 8.1 and 8.2). The head curves of the various pumps are plotted on the same diagram, and their intersections with the system-head curve show possible operating points. *Combined pump head curves* are drawn by adding the flow rates of the various combinations of pumps for as many values of the head as necessary. The intersection of any combined  $H$ - $Q$  curve with the system-head curve is an operating point. Figure 40 shows two pump head curves and the combined curve. Points 1, 2, and 3 are possible operating conditions. Additional operating points may be obtained by changing the speed of the pumps or by increasing the system-head loss by throttling. Any number of pumps in parallel may be included on a single diagram, although separate diagrams for different combinations of pumps may be preferable.

The overall efficiency  $\eta$  of pumps in parallel is given by

$$\eta = \frac{H(\text{sp. gr.})}{k} \times \frac{\sum Q}{\sum P} \quad (31)$$

where  $H$  = head, ft (m)

sp. gr. = specific gravity of the liquid

$k$  = 3960 USCS (0.1021 SI)

$\sum Q$  = sum of the pump flow rates, gpm (l/s)

$\sum P$  = total power supplied to all pumps, hp (W)

**Series Operation** Pumps are frequently operated in series to supply heads greater than those of the individual pumps. The planning procedure is similar to the case of pumps in parallel. The system-head curve and the individual head-flow curves for the pumps are plotted as shown in Figure 41. The pump heads are added as shown to obtain the combined pump head curve. In this example, Pump 2 operating alone will deliver no liquid because its shutoff head is less than the system static head.

There are two possible operating points, 1 and 2, as shown by the appropriate intersections with the system-head curve. As with parallel operation, other operating points

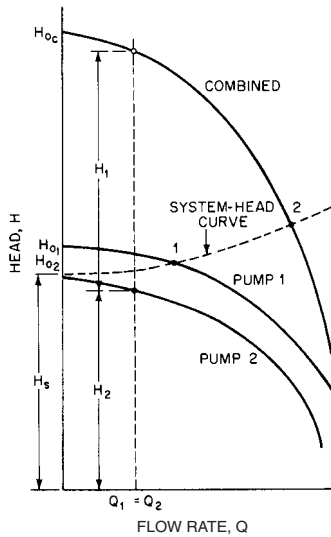


FIGURE 41 Head-flow curves of pumps operating in series

could be obtained by throttling or by changing the pump speeds. The overall efficiency of pumps in series is given by

$$\eta = \frac{Q(\text{sp. gr.})}{k} \times \frac{\sum H}{\sum P} \quad (32)$$

wherein the symbols are the same as for parallel operation. It is important to note that the stuffing box pressure of the second pump is increased by the discharge pressure of the first pump. This may require a special packing box for the second pump with leakoff to the suction of the first pump. The higher suction pressure may increase both the first cost and the maintenance costs of the second pump.

### OPERATION AT OTHER THAN THE NORMAL FLOW RATE

Centrifugal pumps usually are designed to operate near the point of best efficiency, but many applications require operation over a wide range of flow rates, including shutoff, for extended periods of time. Pumps for such service are available but may require special design and construction at higher cost. Noise, vibration, and cavitation may be encountered at low flow rates. Large radial shaft forces at shutoff as well as lack of through flow to provide cooling may cause damage or breakage to such parts as shafts, bearings, seals, glands, and wearing rings of pumps not intended for such service. Some of the phenomena associated with operation at other than normal flow rate are described below.

**Recirculation** There is a small flow from impeller discharge to suction through the wearing rings and any hydraulic balancing device present. This takes place at all flow rates, but does not usually contribute to raising the liquid temperature very much unless operation is near shutoff.

When the flow rate has been reduced by throttling (or as a result of an increase in system head), a secondary flow called *recirculation* begins. Recirculation is a flow reversal due to separation at the suction and at the discharge tips of the impeller vanes. All impellers

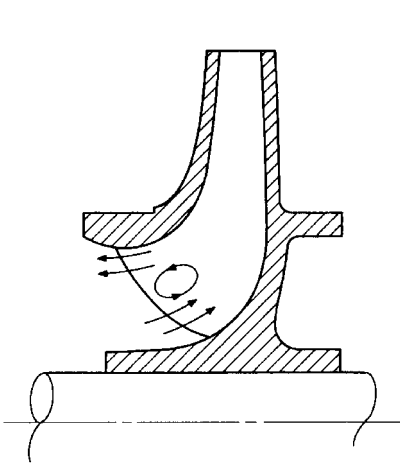


FIGURE 42 Suction recirculation

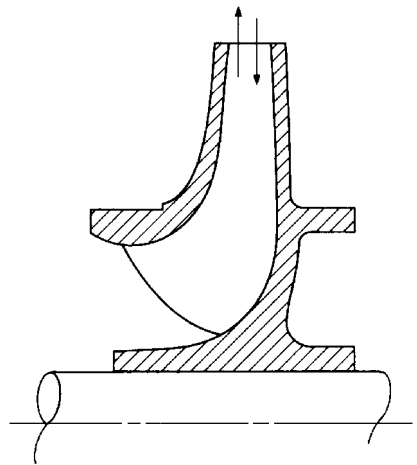


FIGURE 43 Discharge recirculation

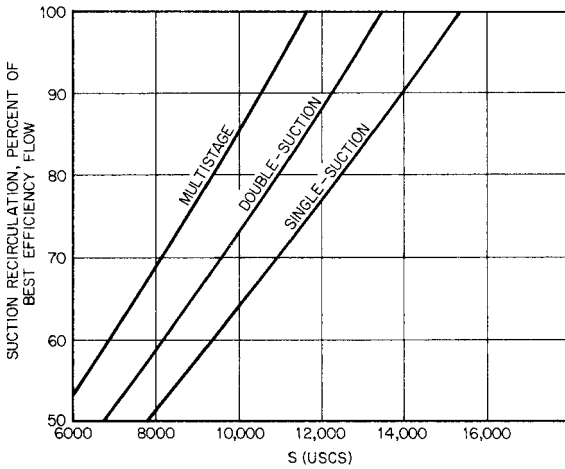
have a critical flow rate at which recirculation occurs. The flow rates at which suction and discharge recirculation begin can be controlled to some extent by design, but recirculation cannot be eliminated (see Figure 6 in Section 2.1).

Suction recirculation is the reversal of flow at the impeller eye. A portion of the flow is directed out of the eye at the eye diameter, as shown in Figure 42, and travels upstream with a rotational velocity approaching the peripheral velocity of the diameter. A rotating annulus of liquid is produced upstream from the impeller inlet, and through the core of this annulus passes an axial flow corresponding to the output flow rate of the pump. In pumps equipped with long, straight suction nozzles but no suction elbow, this rotating fluid has been detected over considerable distances upstream from the impeller eye. Suction pressures measured at wall taps where this phenomenon is present are always higher than the true average static pressure across the measuring section. This means that the pump head as determined from wall taps is less than it would be if true average static pressures were measured. The high shear rate between the rotating annulus and the axial flow through the core produces vortices that form and collapse, producing noise and cavitation in the suction of the pump.

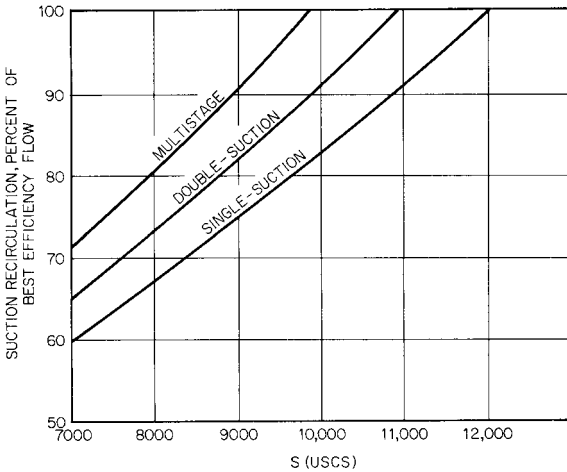
Discharge recirculation is the reversal of flow at the discharge tips of the impeller blades, as shown in Figure 43. The high shear rate between the inward and outward relative velocities produces vortices that cavitate and can attack the pressure side of the blades. This phenomenon, which tends to occur at a lower flow rate than the highest  $Q$  for suction recirculation, also involves stalled flow from the diffuser vanes or volute tongue(s). Separated reversed flow recirculates and emerges from these vane systems back into the impeller with negative swirl (that is, swirl opposite to the direction of rotation). The impeller must expend significant power to redirect the portion of this fluid (that reenters it) out again—with positive swirl. As discussed in Section 2.1, the portion of this backflow from the diffuser or volute that enters the spaces outside the impeller shrouds and adjacent to the casing walls has the potential to reverse the axial thrust of the impeller, and this reversal can fluctuate if the backflow is unsteady (as separated, recirculating flow normally is) and not always feeding the same side of the impeller.

The flow rate  $Q_{sr}$  below which suction recirculation occurs is directly related to the design suction-specific speed  $S$  of the pump. The higher the suction-specific speed, the closer will be the beginning of recirculation to the flow rate at best efficiency. Figure 44 shows the relation between the suction specific speed and suction recirculation for pumps





**FIGURE 44** Influence of the design value of suction specific speed  $S$  on the flow rate  $Q_{SR}$  below which suction recirculation occurs.  $500 < n_s < 2500$ ; ( $0.18 < \Omega_s < 0.91$ ) for single-suction or one side of a double-suction impeller. The ordinate is  $Q_{SR}/Q_{BEP}$  in percent. (To obtain  $\Omega_{ss}$ , divide  $S$  by 2733.)



**FIGURE 45** Influence of the design value of suction specific speed  $S$  on the flow rate  $Q_{SR}$  below which suction recirculation occurs.  $2500 < n_s < 10,000$ ; ( $0.91 < \Omega_s < 3.66$ ) for single-suction or one side of a double-suction impeller. The ordinate is  $Q_{SR}/Q_{BEP}$  in percent. (To obtain  $\Omega_{ss}$ , divide  $S$  by 2733.)

up to 2500 (0.915) specific speed, and Figure 45 shows the same relation for pumps up to 10,000 (3.659) specific speed.

Despite the existence of suction and discharge recirculation, the mechanical response of the pump will not be serious unless the energy level is high. In other words, most pumps can indeed be operated at  $Q < Q_{SR}$ . The minimum flow rate or simply “minimum flow”  $Q_{min}$  is quantified in Section 2.1. As energy level is increased,  $Q_{min}$  approaches  $Q_{SR}$  in the limit. Examples of the difference between  $Q_{min}$  and  $Q_{SR}$  are as follows: For water pumps rated at 2500 gpm (158 l/s) and 150 ft (45.7 m) total head or less, the minimum operating flows can

be as low as 50% of the suction recirculation values shown for continuous operation and as low as 25% for intermittent operation. For hydrocarbons, the minimum operating flows can be as low as 60% of the suction recirculation values shown for continuous operation and as low as 25% for intermittent operation.<sup>51, 52, 53</sup>

**Temperature Rise** Under steady-state conditions, friction and the work of compression increase the temperature of the liquid as it flows from suction to discharge. A further temperature increase may arise from liquid returned to the pump suction through wearing rings, a balancing device, or a minimum-flow bypass line that protects the pump when operating at or near shutoff.

Assuming that all heat generated remains in the liquid, the temperature rise is

$$\Delta T = \frac{gH \times (1 - \eta)}{g_o C_p \eta J} + \Delta T_c \quad (33)$$

where  $g/g_o = 1$  lbf/lbm; but when using SI units,  $g/g_o$  is replaced by  $9.80665 \text{ m/s}^2 (= g$  in the SI system).  $\Delta T_c$  is due to the compression of the liquid and is not a consequence of loss or dissipation as is the term involving the pump efficiency  $\eta$  (see Section 2.1). As shown in Reference 1 of Section 2.1,  $\Delta T_c$  is 3°F per 1000 psi (0.24°C per MPa) of pump pressure rise for hydrocarbon fuels. For boiler feedwater at 350°F (177°C),  $\Delta T_c = 1.6^\circ\text{F}$  per 1000 psi (0.129°C per MPa), but it is much smaller for cold water. By consulting tables of properties for the liquid phase of the fluid being pumped and assuming the compression process between the actual inlet and discharge pressures to be isentropic,  $\Delta T_c$  can be determined. This is important if Eq. 33 is used to evaluate overall pump efficiency from temperature rise measurements.  $\Delta T$  and  $\Delta T_c$  are often of the same order of magnitude at BEP, and serious errors have been made by excluding  $\Delta T_c$  from the efficiency computation. At very low, off-BEP flow rates,  $\Delta T$  will be high in comparison to  $\Delta T_c$ ; so, the latter can be safely ignored in temperature rise calculations at such low-efficiency conditions.

In practice, determination of efficiency from  $\Delta T$ -measurements is accomplished by the direct thermodynamic method<sup>54</sup>, rather than by the  $\Delta T_c$ -method. Both approaches are based on the definition of pump efficiency as the ratio of an isentropic rise of total enthalpy ( $= g\Delta H$ ) to the actual rise of total enthalpy (Eq. 1 of Section 2.1), allowances being made for the usually small external power losses that do not appear in the pumped fluid (such as bearing drag) and the similarly small effects of heat transferred between pump and surroundings. In the direct thermodynamic method, the enthalpy rise  $\Delta h$  is found from the chain rule,

$$\Delta h = \int dh = \int [(\partial h / \partial p)_T dp + (\partial h / \partial T)_p dT] = a \Delta p + C_p J \Delta T$$

the coefficients  $a$  and  $C_p J$  being average values of the two partial derivatives as found from tables of thermodynamic properties of the fluid. Values of these partial derivatives are conveniently tabulated for water in Reference 54.

General service pumps handling cold liquids may be able to stand a temperature rise as great as 100°F (56°C). Most modern boiler-feed pumps may safely withstand a temperature rise of 50°F (28°C). The NPSH required to avoid cavitation or to prevent flashing of hot liquid returned to the pump suction may be the controlling factor. Minimum flow may be dictated by other factors, such as recirculation and unbalanced radial and axial forces on the impeller. Axial forces can be the controlling factor with single-stage double-suction pumps.

It is especially important to protect even small pumps handling hot liquids from operation at shutoff. This is usually done by providing a bypass line fitted with a metering orifice to maintain the minimum required flow through the pump. In the case of boiler-feed pumps, the bypass flow usually is returned to one of the feed-water the water heaters. Unless especially designed for cold starting, pumps handling hot liquids should be warmed up gradually before being put into operation.

**Radial Thrust** Ideally, the circumferential pressure distribution at the impeller exit is uniform at the design condition (as explained in Section 2.1); however, it becomes non-

uniform at off-BEP flow rates. An exception is that concentric collecting configurations will produce non-uniform pressure distributions at the BEP. Any non-uniformity leads to a radial force on the pump shaft called the radial thrust or radial reaction. The radial thrust  $F_r$ , in pounds (newtons) is

$$F_r = kK_r(\text{sp. gr.})HD_2b_2 \quad (34)$$

where  $k = 0.433$  USGS (9790 SI)

$K_r$  = experimentally determined coefficient

sp. gr. = specific gravity of the liquid pumped (equal to unity for cold water)

$H$  = pump head, ft (m)

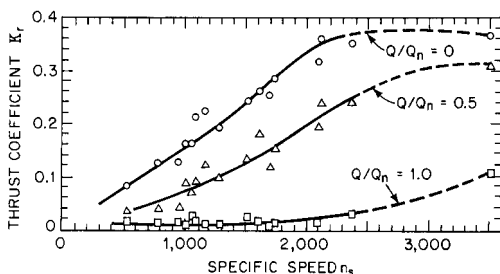
$D_2$  = outside diameter of impeller, in (m)

$b_2$  = breadth of impeller at discharge, including shrouds, in (m)

Values of  $K_r$ , determined by Agostinelli et al.<sup>55</sup> for single-volute pumps are given in Figure 46 as functions of specific speed and flow rate. The magnitude and direction of  $F_r$  on the pump shaft may be estimated from Figure 47, but Eq. 34 probably will be more accurate for determining the magnitude of the force. The radial thrust usually is minimum near  $Q = Q_n$ , the flow rate at best efficiency, but rarely goes completely to zero. Near shutoff,  $F_r$  usually is maximum and may be a considerable force on the shaft in high-head pumps.

The radial thrust can be made much smaller throughout the entire flow-rate range by using a double volute (twin volute) or a concentric casing. These designs should be considered, particularly if the pump must operate at small flow rates. Figures 48 to 50 compare radial forces generated by three types of casings: a standard volute, a double volute, and a modified concentric casing. The latter casing was concentric with the impeller for  $270^\circ$  from the tongue and then enlarged in the manner of a single volute to form the discharge nozzle. The magnitude and direction of  $F_r$  on the pump shaft for the modified concentric casing may be estimated from Figure 51. The direction of  $F_r$  on the pump shaft with a double volute was somewhat random but in the general vicinity of the casing tongue. Radial forces on pumps fitted with diffuser vanes usually are rather small, although they may be significant near shutoff due to stall in some of the passages and not in others.

**EXAMPLE** Consider a single-stage centrifugal pump,  $n_s = 2000$  (0.732) at best efficiency, handling cold water, sp. gr. = 1.0. Estimate the radial thrust on the impeller at half the normal flow rate when fitted with (a) a single volute, (b) a modified concentric casing, and (c) a double volute. Impeller dimensions are  $D_2 = 15.125$  in (38.4 cm) and  $b_2 = 2.5$  in (6.35 cm). The shutoff head is  $H = 252$  ft (76.8 m), and the head at half capacity is  $H = 244$  ft (74.4 m).



**FIGURE 46**  $K_r$  as a function of specific speed and flow rate for single-volute pumps (to obtain  $\Omega_s$ , divide by 2733.) (Reference 55)

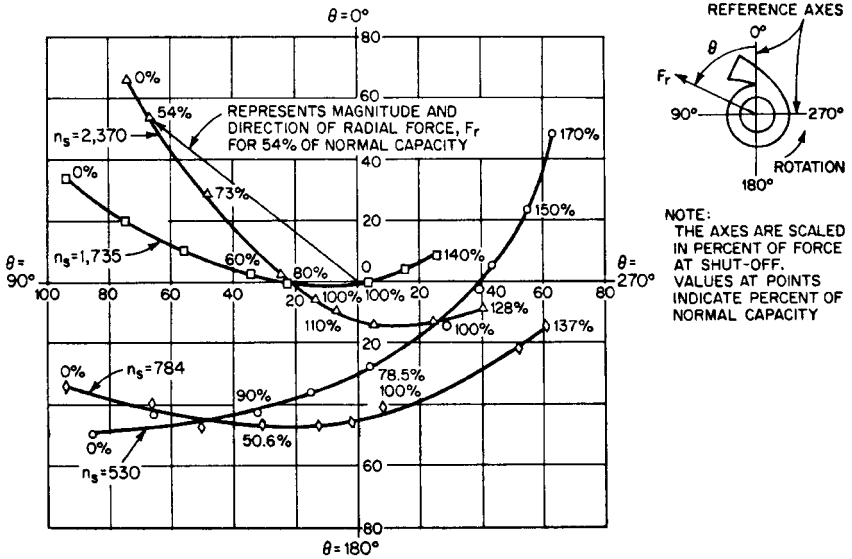


FIGURE 47 Polar plot showing direction of resultant radial forces for single-volute pumps at various flow rates ("capacities") and specific speeds. To obtain  $\Omega_r$ , divide by 2733. (Reference 55)

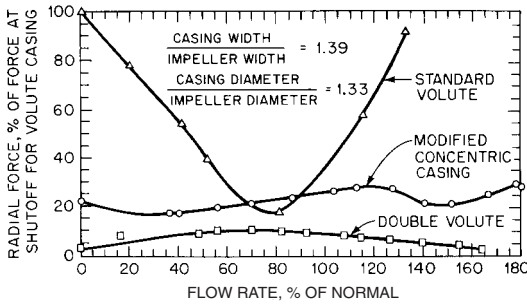


FIGURE 48 Comparison of the effect of three casing designs on radial forces for  $n_s = 1165$  (0.426) (Reference 55)

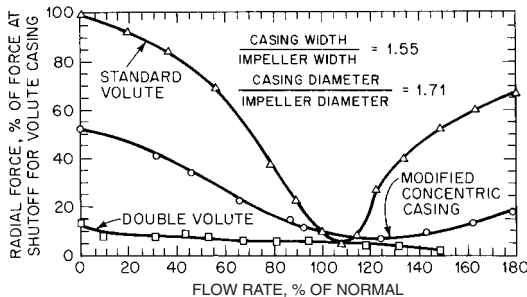


FIGURE 49 Comparison of the effect of three casing designs on radial forces for  $n_s = 2120$  (0.776) (Reference 55)

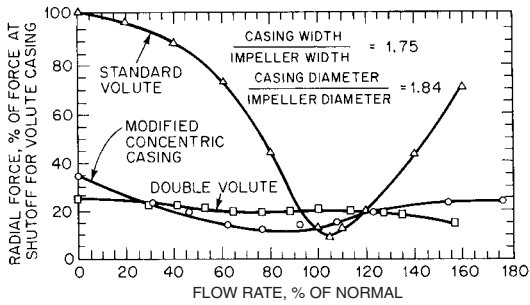


FIGURE 50 Comparison of effect of three casing designs on radial forces for  $n_s = 3500$  (1.281) (Reference 55)

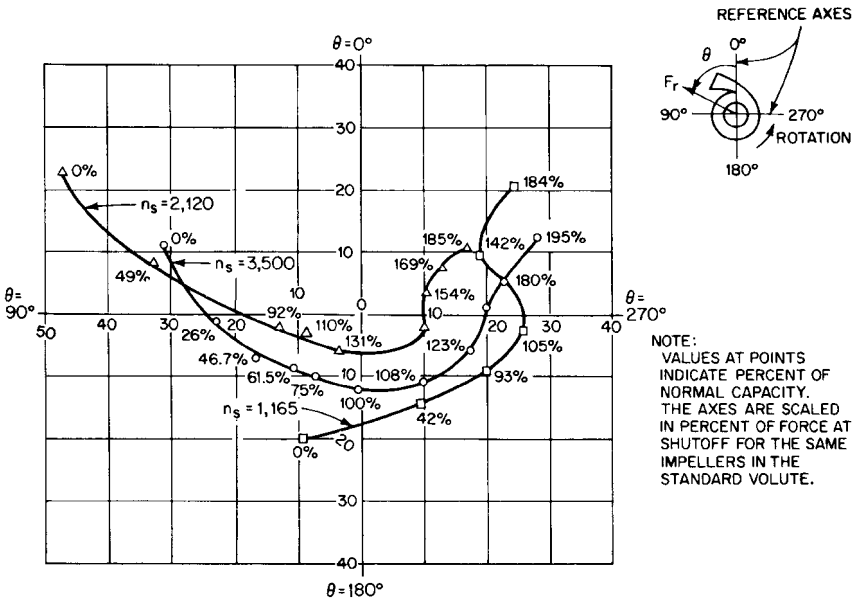


FIGURE 51 Polar plot showing direction of resultant radial forces for modified concentric casings at various flow rates and specific speeds; namely, 1,165 (0.426), 2,120 (0.776), and 3500 (1.281). The casings were concentric for 270° from the tongue. (Reference 55)

*Solution*

(a)  $K_r = 0.2$  from Figure 46, by Eq. 34.

$$F_r = (0.433)(0.2)(1.0)(244)(15.125)(2.5) = 799 \text{ lb (3554 N)}$$

Estimating between the curves for  $n_s = 2370$  (0.867) and 1735 (0.635) in Figure 47, the direction of  $F_r$  on the shaft should be about 65° to 70° from the casing tongue in the direction of rotation.

(b) Use Figure 49,  $n_s = 2120$  (0.776), which is nearest to  $n_s = 2000$  (0.730), to find the radial force for a modified concentric casing at half flow, which is about 33%

of shutoff value for a single-volute casing. From Figure 46, for a single-volute casing at shutoff,  $K_r = 0.34$  and

$$F_r = (0.433)(0.34)(1.0)(252)(15.125)(2.5) = 1403 \text{ lb (6241 N)}$$

Then, for a modified concentric casing at half flow,

$$F_r = (0.33)(1403) = 463 \text{ lb (2059 N)}$$

From Figure 51, the direction of  $F_r$  should be about  $75^\circ$  to  $80^\circ$  from the casing tongue in the direction of rotation.

- (c) From Figure 49, the radial force for a double-volute casing is about 8% of the shutoff value for the single-volute casing, and so

$$F_r = (0.08)(1403) = 112 \text{ lb (499 N)}$$

According to Agostinelli et al.,<sup>55</sup> the direction of the radial thrust in double-volute casings was found to be generally toward the casing tongue. Stepanoff<sup>52</sup> has found this direction to follow approximately that in single-volute casings (see also Biheller<sup>56</sup>).

**Axial Thrust** See Section 2.1 and 2.2.1.

## ABNORMAL OPERATION

---

**Complete Pump Characteristics** Many types of abnormal operation involve reversed pump rotation, reversed flow direction, or both, and special tests are required to cover these modes of operation. Several methods of organizing the data have been proposed, and each has certain advantages. The Thoma diagrams shown in Figures 52 and 53<sup>45</sup> are easily understood and are truly *complete characteristics diagrams* because all possible modes of operation are covered (see also Reference 57).

Figure 54 shows schematic cross-sections of the two pumps tested by Swanson<sup>58</sup> for which characteristics are given in Figure 53.

The *Karman circle diagram* (Reference 59) attempted to show the complete characteristics as a four-quadrant contour plot of surfaces representing head and torque with speed and flow rate as base coordinates. Because the head and torque tend to infinity in two zones of operation, another diagram would be required to show the complete pump characteristics. The data presented in such a diagram are, nevertheless, adequate for almost all requirements. One example of a circle diagram is given in Figures 55 and 56. Other examples may be found in References 12, 58, and 59.

Frequently, tests with negative head and torque have been omitted so that only half of the usual circle diagram could be shown. This has been called a *three-quadrant plot*, but the information necessary to predict an event, such as possible water-column separation following a power failure, is lacking.

**Power Failure Transient** A sudden power failure that leaves a pump and driver running free may cause serious damage to the system. Except for rare cases where a flywheel is provided, the pump and driver usually have a rather small moment of inertia, and so the pump will slow down rapidly. Unless the pipeline is very short, the inertia of the liquid will maintain a strong forward flow while the decelerating pump acts as a throttle valve. The pressure in the discharge line falls rapidly and, under some circumstances, may go below atmospheric pressure, both at the pump discharge and at any points of high elevation along the pipeline. The minimum pressure head which occurs during this phase of the motion is called the *downsurge*, and it may be low enough to cause vaporization followed by complete separation of the liquid column. Pipelines have collapsed under the external atmospheric pressure during separation. When the liquid columns rejoin, following separation, the shock pressures may be sufficient to rupture the pipe or the pump

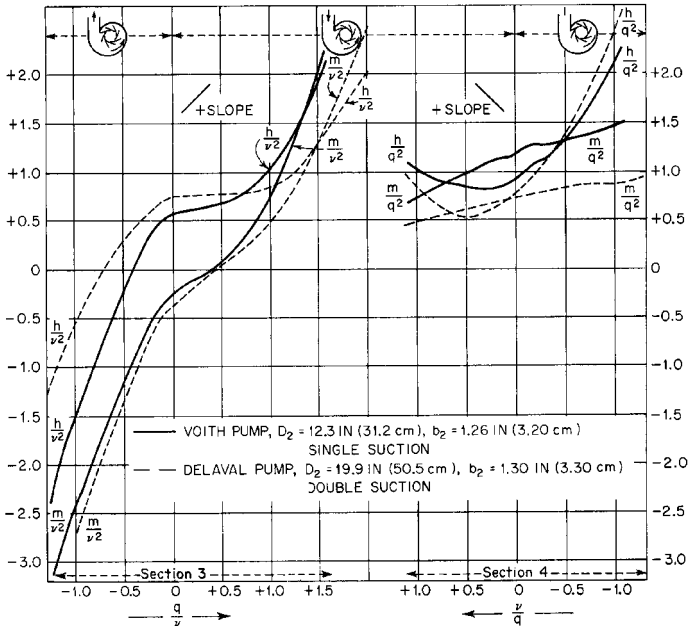
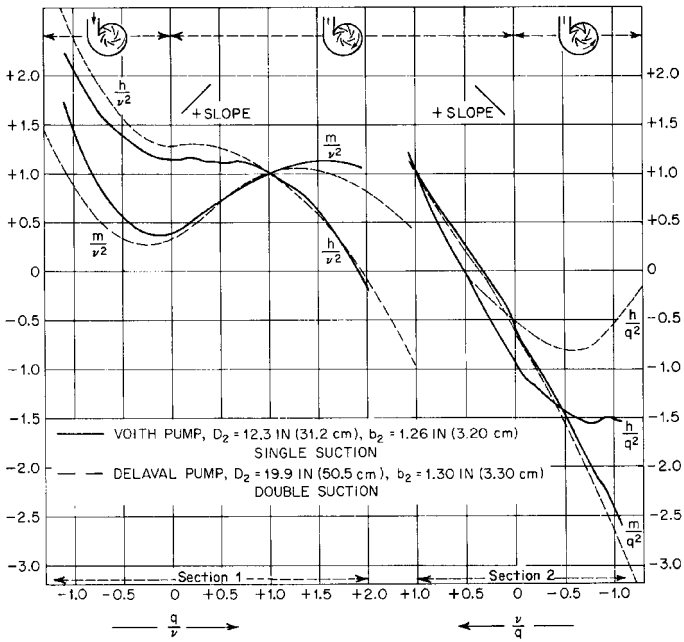
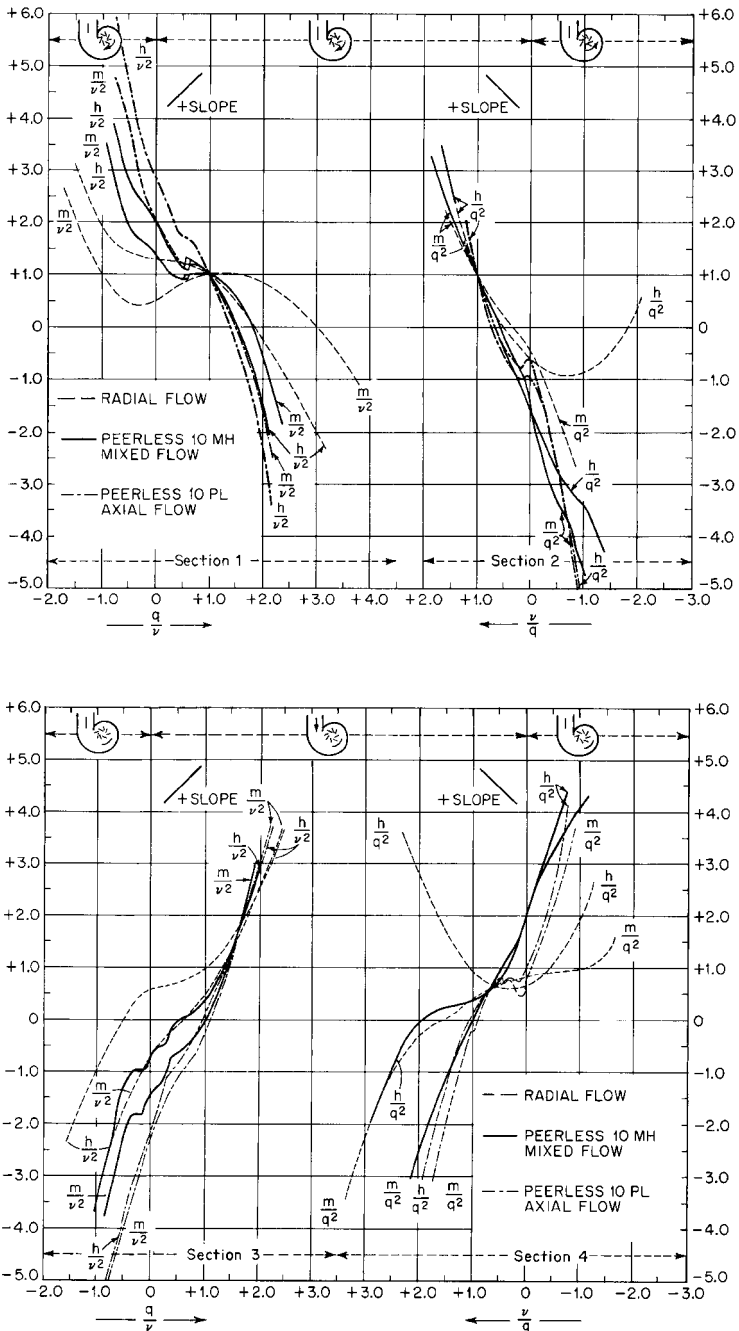
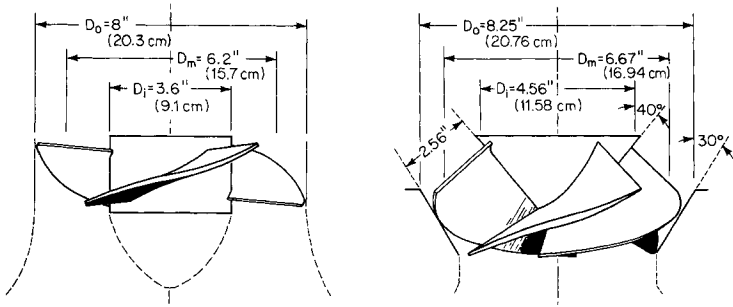


FIGURE 52 Complete pump characteristics. Specific speeds: Voith pump  $n_s = 1,935$  (0.708); Delaval pump  $n_s = 1,500$  (0.549). (Reference 45)



**FIGURE 53** Complete pump characteristics. Specific speeds: Radial flow -  $n_s = 1800$  (0.659); Peerless 10MH mixed flow -  $n_s = 7,550$  (2.763); Peerless 10PL axial flow -  $n_s = 13,500$  (4.940). (Reference 45)





**FIGURE 54** Schematic cross sections of high-specific-speed pumps.  $n_s = 13,500$  (4.940) for axial flow pump;  $n_s = 7,550$  (2.763) (Reference 45)

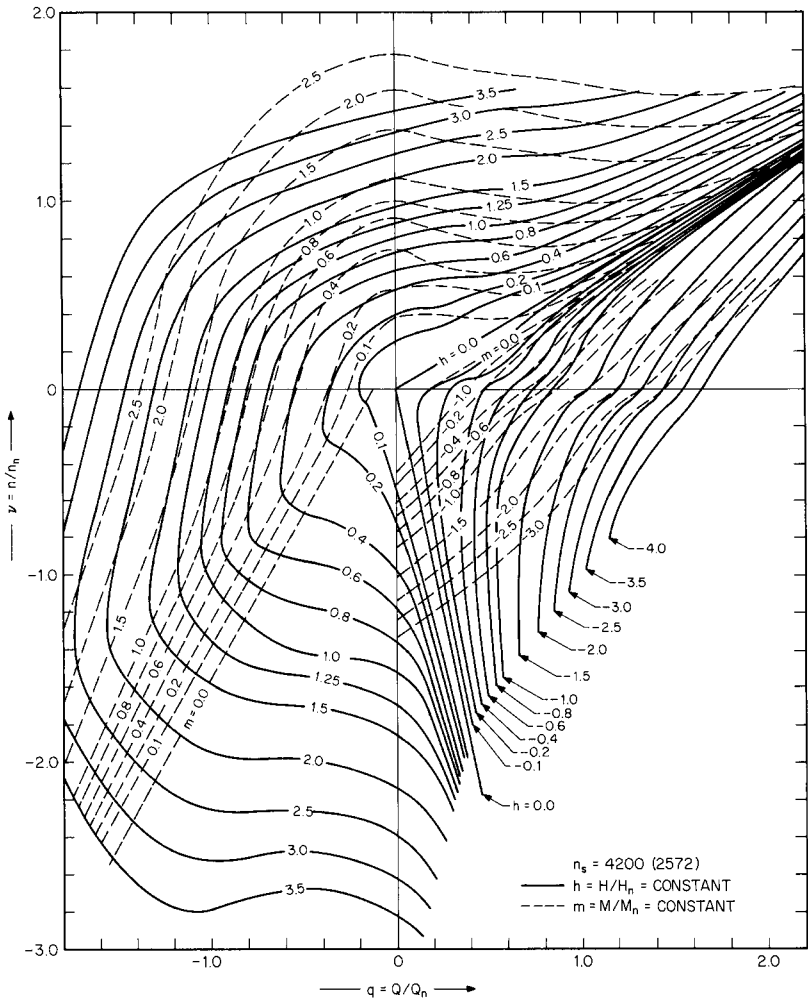
casing. Closing a valve in the discharge line will only worsen the situation, and so valves having programmed operation should be closed very little, if at all, before reverse flow begins.

Reversed flow may be controlled by valves or by arranging to have the discharge pipe empty while air is admitted at or near the outlet. If reversed flow is not checked, it will bring the pump to rest and then accelerate it with reversed rotation. Eventually the pump will run as a turbine at the runaway speed corresponding to the available static head diminished by the frictional losses in the system. However, while reversed flow is being established, the reversed speed may reach a value considerably in excess of the steady-state runaway speed. Maximum reversed speed appears to increase with increasing efficiency and increasing specific speed of the pump. Calculations indicate maximum reversed speeds more than 150% of normal speed for  $n_s = 1935$  (0.708) and  $\eta = 84.1\%$ <sup>45</sup>. This should be considered in selecting a driver, particularly if it is a large electric motor.

There will be a pressure increase, called the *upsurge*, in the discharge pipe during reversed flow. The maximum upsurge usually occurs a short time before maximum reversed speed is reached and may cause a pressure as much as 60% or more above normal at the pump discharge. A further discussion of power-failure transients is given in Section 8.3.

**ANALYSIS OF TRANSIENT OPERATION** The data of Figures 52 and 53 have been presented in a form suitable for general application to pumps having approximately the same specific speeds as those tested. The symbols are  $h = H/H_n$ ,  $q = Q/Q_n$ ,  $m = M/M_n$ , and  $v = n/n_n$ , wherein  $H$ ,  $Q$ ,  $M$ , and  $n$  represent instantaneous values of head, flow rate, torque, and speed respectively and the subscript  $n$  refers to the values at best efficiency for normal constant-speed pump operation. Any consistent system of units may be used. According to the affinity laws (Eqs. 12),  $q$  is proportional to  $v$ , and  $h$  and  $m$  are proportional to  $v^2$ . Thus the affinity laws are incorporated in the scales of the diagrams. Figures 52 and 53 are divided into sections for convenience in reading data from the curves. The curves of sections 1 and 3 extend to infinity as  $q/v$  increases without limit in either the positive or negative direction. This difficulty is eliminated by sections 2 and 4, where the curves are plotted against  $v/q$ , which is zero when  $q/v$  becomes infinite.

Usually any case of transient operation would begin at or near the point  $q/v = v/q = 1$ , which appears in both sections 1 and 2 of Figures 52 and 53. The detailed analysis of transient behavior is beyond the scope of this treatise. An analytical solution by the rigid column method, in which the liquid is assumed to be a rigid body, is given in Reference 45. Friction is easily included, and the results are satisfactory for many cases. The same reference includes a semigraphical solution to allow for elastic waves in the liquid, but friction must be neglected. Graphical solutions including both elastic waves and friction are discussed in References 45 to 48. Computer solutions of a variety of transient problems are discussed in Reference 47. These offer considerable flexibility in the analysis once the necessary programs have been prepared.



**FIGURE 55** Circle diagram of pump characteristics. Specific speed  $n_s = 4200$  (1.537). (Courtesy Combustion Engineering)

Some extreme conditions of abnormal operation can be estimated at points where the curves of Figures 52 and 53 cross the zero axes and are listed in Table 9. The data for Columns 2 to 4 of Table 9 were read from Sections 2 of Figures 52 and 53, and the data for Columns 6 and 7 were read from Sections 3. Column 8 was computed from Column 7 by assuming  $h = 1$ . Let the pump having  $n_s = 1500$  (0.549) deliver cold water with normal head  $H_n = 100$  ft (30.48 m), and let the center of the discharge flange be 4 ft (1.2 m) above the free surface in the supply sump. The discharge pressure head following power failure may be estimated by assuming the inertia of the rotating elements to be negligible relative to the inertia of the liquid in the pipeline. Then  $q = 1$  and, from Column 2 of Table 9, the downsurge pressure head is  $(-0.22)(100) - 4 = -26$  ft ( $-7.9$  m), which is not low enough to cause separation of the water column.

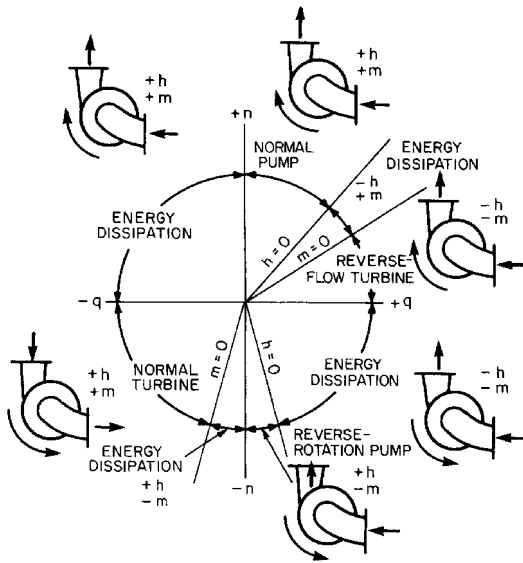


FIGURE 56 Explanatory diagram for Figure 55

TABLE 9 Abnormal operating conditions of several pumps

Specific speed $n_s$ ( $\Omega_s$ )	Downsurge				Runaway turbine		
	Free-running $m/q^2 = 0$		Locked-rotor $v/q = 0$		$m/v^2 = 0$		$h = 1$
	$h/q^2$	$v/q$	$h/q^2$	$m/q^2$	$q/v$	$h/v^2$	$v$
1	2	3	4	5	6	7	8
1500 (0.549) <sup>a</sup>	-0.22	0.36	-0.55	-0.53	0.46	0.77	1.14
1800 (0.659)	-0.24	0.31	-0.60	-0.44	0.56	0.75	1.16
1935 (0.708)	-0.36	0.32	-0.94	-0.60	0.41	0.66	1.23
7550 (2.763)	-0.23	0.56	-1.57	-1.38	0.99	0.38	1.62
13,500 (4.940)	-0.12	0.67	-0.96	-0.60	1.08	0.33	1.73

<sup>a</sup>Double-suction.

Actually the downsurge would be less than this because of the effects of inertia and friction, which have been neglected. If this pump were stopped suddenly by a shaft seizure or by an obstruction fouling the impeller, Column 4 of Table 9 shows the downsurge to be  $(-0.55)(100) - 4 = -59$  feet (-18 m), which would cause water column separation and, probably, subsequent water hammer. If, following power failure, the pump were allowed to operate as a no-load turbine under the full normal pump head, Column 8 of Table 9 shows the runaway speed would be 1.14 times the normal pump speed. The steady-state runaway speed usually would be less than this because the effective head would be decreased by friction, but higher speeds would be reached during the transient preceding steady-state operation. Column 8 shows that runaway speeds increase with increasing specific speed.

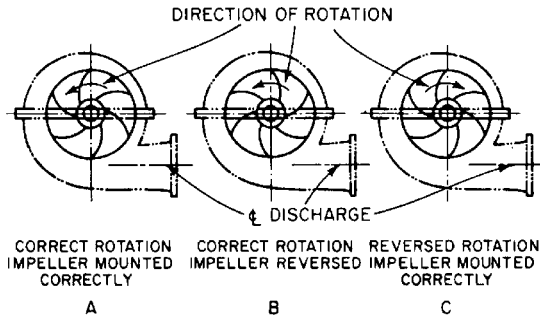


FIGURE 57A through C Pump assembly and rotation (Reference 7)

**Incorrect Rotation** Correct rotation of the driver should be verified before it is coupled to the pump (Figure 57). Sections 3 of Figures 52 and 53 show that reversed rotation might produce some positive head and flow rate with pumps of low specific speed, but at very low efficiency. It is unlikely that positive head would be produced by reversed rotation of a high-specific-speed pump.

**Reversed Impeller** Some double-suction impellers can be mounted reversed on the shaft. If the impeller is accidentally reversed, as at *B* in Figure 57, the flow rate and efficiency probably will be much reduced and the power consumption increased. Care should be taken to prevent this, as the error might go undetected in some cases until the driver was damaged by overload. Table 1 shows performance data for six pumps with reversed impellers. At least one of these would overload the driver excessively.

Further discussion of abnormal operating conditions may be found in References 7, 12, and 34.

**Vibration** Vibration caused by flow through wearing rings and by cavitation has been discussed in the foregoing and some remedies indicated. Vibration due to unbalance is not usually serious in horizontal units but may be of major importance in long vertical units, where the discharge column is supported at only one or two points. The structural vibrations may be quite complicated and involve both natural frequencies and higher harmonics. Vibration problems in vertical units should be anticipated during the design stage. If vibration is encountered in existing units, the following steps may help to reduce it: (1) dynamically balance all rotating elements of both pump and motor; (2) increase the rigidity of the main support and of the connection between the motor and the discharge column; (3) change the stiffness of the discharge column to raise or lower natural frequencies as required. A portable vibration analyzer may be helpful in this undertaking. Kovats<sup>60</sup> has discussed the analysis of this problem in some detail.

Structural vibrations can occur in most pump types. Typical sources are a) bearing housings—due to the commonly encountered cantilever construction, b) couplings, c) rotor instabilities stemming from excessive ring clearances and consequent loss of Lomakin stiffening of long-shaft multistage pumps, and d) hydraulic unbalance—due to dimensional variations in flow passages and clearances<sup>61</sup>.

## PREDICTION OF EFFICIENCY FROM MODEL TESTS

Many pumps used in pumped storage power plants and water supply projects are so large and expensive that extensive use is made of small models to determine the best design. It is often necessary to estimate the efficiency of a prototype pump, as a part of the guaran-

tee, from the performance of a geometrically similar model. A model and prototype are said to operate under dynamically similar conditions when

$$Dn/\sqrt{H} = D'n'/\sqrt{H'}$$

where  $D$  = impeller diameter

$n$  = pump speed

$H$  = pump head

in any consistent units of measure. Primed quantities refer to the model and unprimed quantities to the prototype. Dynamic similarity is a prerequisite to model-prototype testing so that losses that are proportional to the squares of fluid velocities, called *kinetic losses*, will scale directly with size and not change the efficiency. Surface frictional losses are boundary-layer phenomena which depend on Reynolds number

$$Re = D\sqrt{H}/\nu,$$

where  $\nu$  = kinematic viscosity of the liquid pumped.

(See also Section 2.1, Eqs. 36–40.) Reynolds numbers increase with increasing size, and, within limits, surface frictional-loss coefficients decrease with increasing Reynolds number. This leads to a gain in efficiency with increasing size. Computational difficulties have forced an empirical approach to the problem. Details of the development of a number of formulas are given in Reference 62.

**Moody-Stauffer Formula** In 1925, L. F. Moody and F. Stauffer independently developed a formula that was later modified by Pantell to the form

$$\left(\frac{1 - \eta_h}{1 - \eta'_h}\right) \left(\frac{\eta'_h}{\eta_h}\right) = \left(\frac{D'}{D}\right)^n \quad (35)$$

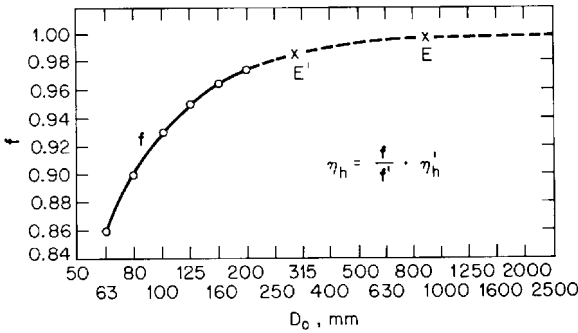
where  $\eta_h$  = hydraulic efficiency, discussed previously, and  $D$  = impeller diameter. Primed quantities refer to the model, and  $n$  is a constant to be determined by tests. The model must be tested with the same liquid that will be used in the prototype; that is, cold water in most practical cases. The original formula contained a correction for head, which is negligible if  $H' \geq 0.8H$ , and this requirement is now virtually mandatory in commercial practice. The meager information available indicates  $0.2 \geq n \geq 0.1$  approximately, with the higher value currently favored. Improvements in construction and testing techniques very likely will move  $n$  toward lower value in the future. The Moody-Stauffer formula has been widely used since first publication. In practice, both  $\eta'_h$  and  $\eta_h$  are usually replaced by the overall efficiencies  $\eta'$  and  $\eta$ , respectively, because of the difficulty in determining proper values for the mechanical and volumetric efficiencies (see Eq. 11).

**Rütschi Formulas** The general form of several empirical formulas due to K. Rütschi<sup>62</sup> and others was originally given as

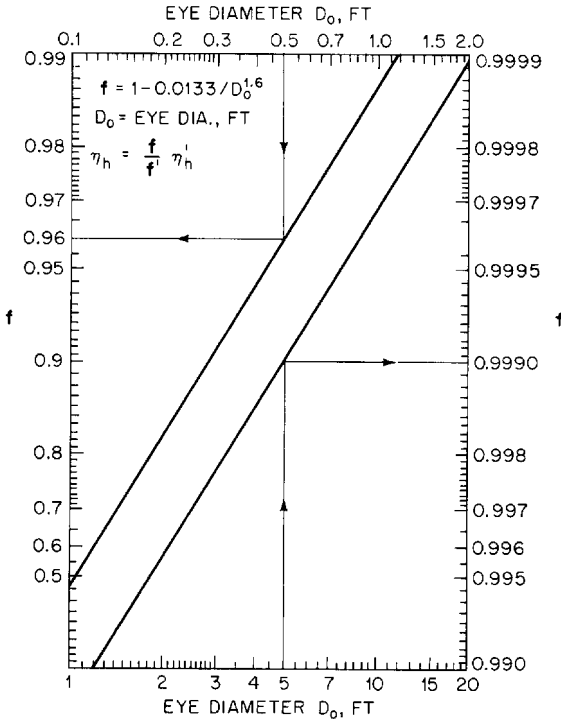
$$\eta_h = \frac{f}{f'} \eta'_h \quad (36)$$

where  $\eta_h$  and  $\eta'_h$  are the hydraulic efficiencies of the prototype and model, respectively, and  $f$  and  $f'$  are values of an empirical  $f$  function for both the prototype and the model. The  $f$  function was obtained from tests of six single-stage pumps.  $n_s < 2000$  (0.732) and is shown in Figure 58 based on the *eye diameters*  $D_o$  of the pumps in *millimeters*. Thus the  $f$  function depends on actual size in addition to scale ratio. The extrapolated portion of the curve, shown dashed in Figure 58, checked well with values for a model and large prototype, shown by  $E'$  and  $E$ , respectively. One of several formulas that have been proposed to fit the curve in Figure 58 is, in SI units,

$$f = 1 - \frac{3.15}{D_o^{1.6}} \quad (37)$$



**FIGURE 58** The  $f$  function for the Rüttschi formula (to obtain  $D_o$ , in inches, multiply by 0.03937) (References 13 and 62)



**FIGURE 59** Chart for the solution of the Rüttschi formula (to obtain  $D_o$  in meters, multiply by 0.3048) (Reference 62)

where the eye diameter  $D_o$  is in centimeters or, in USCS units,

$$f = 1 - \frac{0.0133}{D_o^{1.6}} \tag{38}$$

where  $D_o$  is in feet. Figure 59 gives a graphical solution of Eq. 38. The Society of German Engineers (VDI) has adopted a slightly modified version of the Rüttschi formula as standard. Rüttschi later recommended, in discussion of Reference 62, that the internal effi-

ciency  $\eta_i = \eta/\eta_m$  be used instead of the hydraulic efficiency  $\eta_h$  in Eq. 45. The mechanical efficiency  $\eta_m$  will probably be very high for both model and prototype for most cases of interest, so good results should be obtained if the overall efficiency is used in Eq. 36.

Model-prototype geometric similarity should include surface finish and wearing ring or tip clearances, but this may be difficult or impossible to achieve. Anderson (see Section 2.1: Figure 10 and Reference 6) proposed a method that includes a correction for dissimilarity in surface finish.

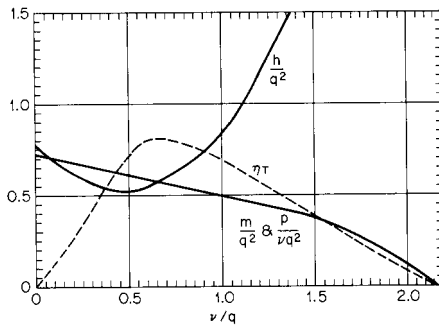
## OPERATION OF PUMPS AS TURBINES

Centrifugal pumps may be used as hydraulic turbines in some cases where low first cost is paramount. Because the pump has no speed-regulating mechanism, considerable speed variation must be expected unless the head and load remain very nearly constant. Some speed control could be obtained by throttling the discharge automatically, but this would increase the cost, and the power lost in the throttle valve would lower the overall efficiency.

**Pump Selection** After the head, speed, and power output of the turbine have been specified, it is necessary to select a pump that, when used as a turbine, will satisfy the requirements. Assuming that performance curves for a series of pumps are available\*, a typical set of such curves should be normalized using the head, power, and flow rate of the best efficiency point as normal values. These curves will correspond to the right part of Section 1 of either Figure 52 or 53. In normalizing the power  $P$ , let  $p = P/P_n$  and the curve of  $p/\nu^3$  will be identical with the curve of  $m/\nu^2$  in Figure 52 or 53. The normalized curves may be compared with the curves in Sections 1 of Figures 52 and 53 to determine which curves best represent the characteristics of the proposed pump. When a choice has been made, the approximate turbine performance can be obtained from the corresponding figure of Figures 60 to 63.

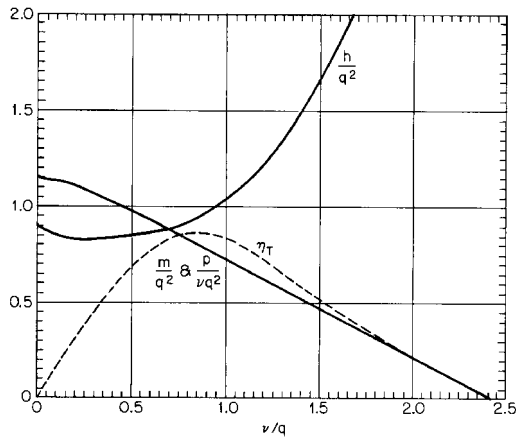
**EXAMPLE** Assume that the turbine specifications are  $H_T = 20$  ft,  $P_T = 12.75$  hp and  $n = 580$  rpm, and that the characteristics of the DeLaval L10/8 pump are representative of a series of pumps from which a selection can be made. The turbine discharge  $Q_T$  in gallons per minute after substituting the above values is

$$Q_T = \frac{3960P_T}{H_T\eta_T} = \frac{2520}{\eta_T} \quad (39)$$

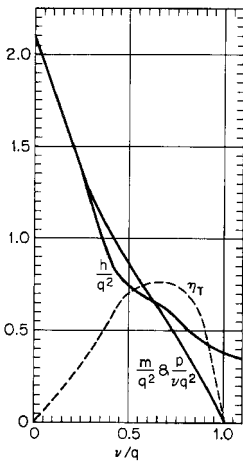


**FIGURE 60** Dimensionless characteristic curves for DeLaval L 10/8 pump, constant-discharge turbine operation (Reference 63)

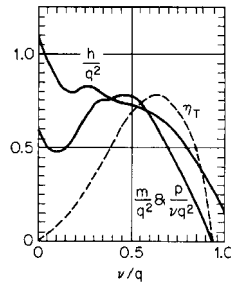
\*It is assumed that turbine mode characteristics of the proposed pump are not available when the initial selection is made.



**FIGURE 61** Dimensionless characteristic curves for Voith pump, constant-discharge turbine operation (Reference 63)



**FIGURE 62** Dimensionless characteristics curves for Peerless 10MH pump, constant-discharge turbine operation (Reference 63)



**FIGURE 63** Dimensionless characteristic curves for Peerless 10PL pump, constant-discharge turbine operation (Reference 63)

where  $\eta_T$  is turbine efficiency, shown in Figure 60. Only the normal values  $Q_n$ ,  $H_n$ ,  $P_n$ , and so on, are common to the curves of both Figures 52 and 60, so these alone can be used in selecting the required pump. Values of  $v/q$ ,  $h/q^2$ , and  $\eta_T$  are read from the curves of Figure 60 and corresponding values of  $Q$  computed by Eq. 39. Values of  $Q_n$  and  $H_n$  are then given by

$$Q_n = Q(v/q) \tag{40}$$

$$H_n = \frac{H(v/q)^2}{h/q^2} = \frac{20(v/q)^2}{h/q^2} \tag{41}$$



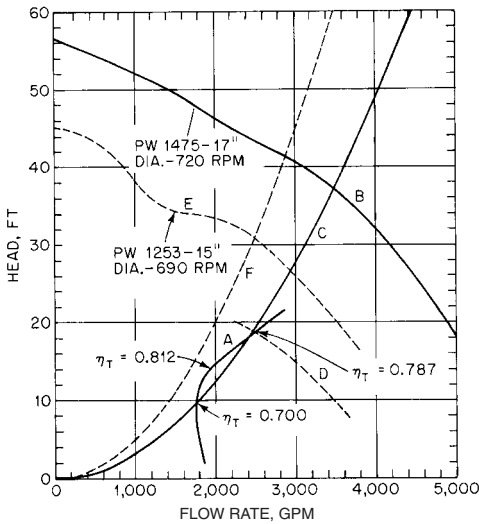


FIGURE 64 Head-flow curves of the pump selection (ft  $\times$  0.3048 = m; gpm  $\times$  0.06300 = l/s) (Reference 63)

For example, in Figure 60 at  $\nu/q = 0.700$ , read  $h/q^2 = 0.595$  and  $\eta_T = 0.805$ . By Eq. 39,  $Q_T = 2520/0.805 = 3130$  gpm; by Eq. 40,  $Q_n = (3130)(0.700) = 2190$  gpm; and by Eq. 41,  $H_n = (20)(0.700)^2/0.9595 = 16.5$  ft. In a similar manner, the locus of the best efficiency points for an infinite number of pumps, each having the same characteristics as shown in Figures 52 and 60, is obtained, and each pump would satisfy the turbine requirements. This locus of best efficiency points is plotted as curve A in Figure 64.

The head curve for a DeLaval L 16/14 pump having a 17-in-diameter impeller tested at 720 rpm is shown as curve B in Figure 64. The best efficiency point was found to be at  $Q_n = 3500$  gpm and  $H_n = 37.2$  ft. The locus of the best efficiency points for this pump for different speeds and impeller diameters is given by Eqs. 12 as

$$H_n = 37.2 \left( \frac{Q_n}{3500} \right)^2 = \frac{3.04}{10^6} Q_n^2 \quad (42)$$

and is shown by curve C in Figure 64. Curve C intersects curve A at two points, showing that the L 16/14 pump satisfies the turbine requirements. Only the intersection at the higher turbine efficiency is of interest. At this point,  $Q_n = 2490$  gpm and  $H_n = 18.8$  ft. Because the turbine speed was specified to be 580 rpm, the required impeller diameter is given by Eqs. 12 as

$$D = \frac{(17)(2490/3500)}{580/720} = 15 \text{ in}$$

or by

$$D = \frac{17\sqrt{18.8/37.2}}{580/720} = 15 \text{ in}$$

The computed head curve for the 15-in-diameter impeller at 580 rpm is shown as curve D in Figure 64. The turbine discharge is 3200 gpm from Eq. 39 with  $\eta_T = 0.787$ .

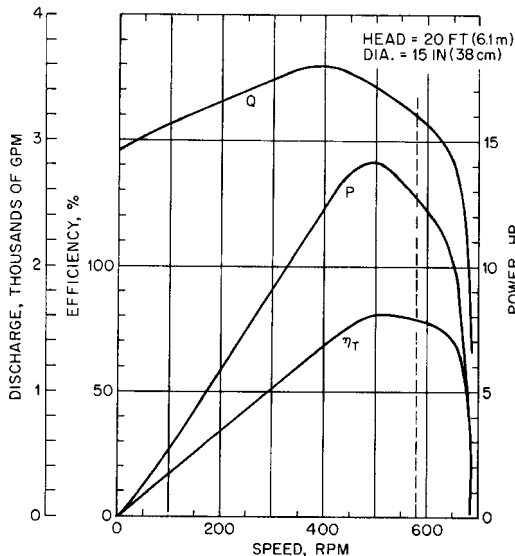
The optimum solution would be to have Curve C tangent to Curve A at the point corresponding to maximum turbine efficiency, in this case  $\eta_T = 0.812$ . Because this

would require a smaller pump, Curve *E* in Figure 64 shows a head curve for a K 14/12 pump, which was the next smaller pump in the series. Curve *F*, the locus of the best efficiency points, does not intersect Curve *A*, showing that the smaller pump will not satisfy the turbine requirements. It is important to note that the turbine head, 20 ft, specified for this example was assumed to be the net head from the inlet to outlet flange of the pump when installed and operated as a turbine.

The procedure outlined above should lead to the selection of a pump large enough to provide the required power. However, it probably will be necessary to apply the affinity laws over such wide ranges of the variables that the usual degree of accuracy should not be expected. Considerable care should be exercised if it becomes necessary to interpolate between the curves of Figures 60 to 63. The computed performance will very likely differ from the results of subsequent tests. The curves of Figure 60 may be converted to show the constant-head characteristics of the L 16/14 pump when installed and operated as a turbine. Details of the method of computation are given in Reference 63, and the computed characteristics are shown in Figure 65.

A comprehensive study by Acres American<sup>64,65</sup> led to a computer program to aid in selecting a pump to meet specific requirements when operating in the turbine mode. Known pump characteristics are entered in the program according to a specified format. The computer compares them with stored characteristics of pumps for which turbine mode characteristics are known and provides estimated turbine mode characteristics for the proposed pump. Vols. I and III of Reference 64 describe the method of computation and give complete instructions for using the program.

**Optimized Hydraulic Turbines** A logical outgrowth of applying pumps as hydraulic turbines is the optimization of these machines as turbines. Several points of efficiency improvement have been demonstrated over that of pumps running in reverse as turbines.<sup>66</sup> The fluid accelerates through both the stator or nozzles and the turbine wheel or runner, whereas it decelerates through the same elements when they are acting as impeller and diffuser or volute in the pumping mode. If the fluid never has to decelerate



**FIGURE 65** Computed constant-head turbine characteristics for DeLaval L 16/14 pump (gpm  $\times$  0.06309 = l/s; hp  $\times$  0.7457 = kW) (Reference 63)

because the turbine will never be used as a pump, the nozzles and runner can be designed to produce more aggressive and efficient acceleration in shorter distances than if the same machine is simply a pump being used as a turbine. If it is a radial-inflow runner, the resulting optimized turbine wheel employs a radial blade (with a blade angle  $\beta = 90$  deg. from the tangential direction) at the outer diameter (inlet). This outer diameter is about 75% of the diameter of the impeller of the pump-as-turbine, which further improves the efficiency by reason of the reduction of the disk friction drag of the runner. Design and application of both approaches is explained and compared in Reference 67. Many of the applications of these hydraulic turbines are for power recovery in the pressure let-down processes that occur in petroleum refining. Another variable is introduced in such processes; namely, the evolution of large volumes of dissolved gas as the pressure decreases through successive stages or portions of the turbine. This phenomenon affects the performance of hydraulic turbines for such applications because somewhat more power is produced when gas evolves from the liquid than when a single-phase liquid flows through the turbine at the same pressure drop and mass flow rate.<sup>68</sup>

## VORTEX PUMPS

A typical vortex pump is shown in Figure 66.\* The ability of this type of pump to handle relatively large amounts of suspended solids as well as entrained air or gas more than offsets the relatively low efficiency. Table 10 lists performance data for four typical vortex pumps and four radial-flow centrifugal pumps of nearly the same head and flow rate. Figure 67 shows the head characteristics of a typical vortex pump with impellers of different diameters together with curves of constant efficiency and constant *NPSH*. Power curves for the same impellers are shown in Figure 68.

Curves for a conventional radial-flow pump have been added for comparison in Figures 67 and 68. Note that the head of the vortex pump does not decrease as rapidly with an increasing flow rate as does the head of the conventional pump. The power requirement of the vortex pump increases almost linearly with an increasing flow rate, whereas the power required by a conventional pump of about the same specific speed reaches a maximum and then decreases with the increasing flow rate.

Thus if the motor of the vortex pump has been selected to match the power required at the normal flow rate for best efficiency, it will be overloaded if the pump operates much beyond that point.

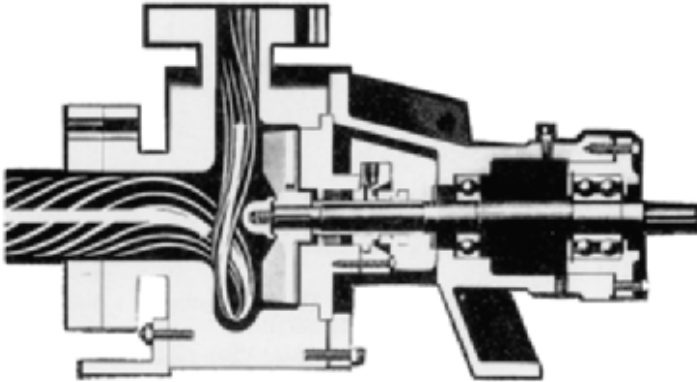


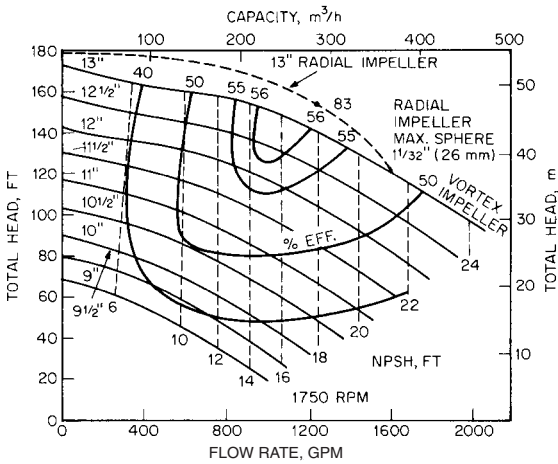
FIGURE 66 Vortex pump (courtesy Fybroc Division, METPRO)

\*See also Section 9.2.

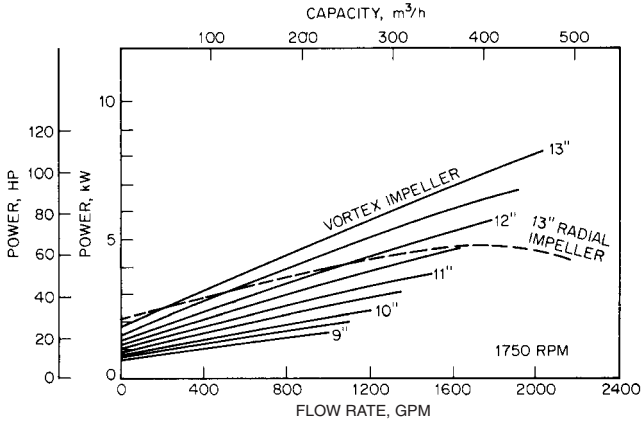
**TABLE 10** Characteristics of typical vortex pumps and comparable radial-flow centrifugal pumps at 1750 rpm

Impeller	Flow rate,		Total head,		Specific speed,		Suction specific speed,		Impeller diameter,		Sphere diameter, <sup>a</sup>		Efficiency <sup>b</sup> at $Q = Q_n$ , %	Shutoff power, <sup>b</sup> % $P_n$	Power <sup>b</sup> at $1.5Q_n$ , % $P_n$		Shutoff head, <sup>b</sup> % $H_n$		Head <sup>b</sup> at $1.5Q_n$ , % $H_n$		NPSHR <sup>b</sup> at $Q_n$ , ft (m)		NPSHR <sup>b</sup> at $1.5Q_n$ , ft (m)	
	gpm	(l/s)	ft	(m)	$n_s$	( $\Omega_s$ )	$S$	( $\Omega_{ss}$ )	in	(mm)	in	(mm)							ft	(m)	ft	(m)	ft	(m)
Vortex	100	(6.3)	24	(7.3)	1614	(0.591)	7700	(2.82)	5 $\frac{7}{8}$	(149)	2	(51)	39.5	37.5	131	120	71	3	(0.9)	8	(2.4)			
Radial	108	(6.8)	26	(7.9)	1580	(0.578)	6430	(2.35)	5 $\frac{7}{8}$	(149)	5 $\frac{5}{8}$	(16)	59	50	108	144	50	4	(1.2)	7.5	(2.3)			
Vortex	200	(12.6)	61	(18.6)	1134	(0.415)	7400	(2.71)	8 $\frac{3}{8}$	(213)	2	(51)	45	45	129	123	82	5	(1.5)	8	(2.4)			
Radial	225	(14.2)	60	(18.3)	1218	(0.446)	6450	(2.36)	8 $\frac{3}{8}$	(213)	3 $\frac{3}{4}$	(19)	61	50	130	125	65	6.5	(2.0)	14	(3.4)			
Vortex	850	(53.6)	108	(32.9)	1523	(0.557)	9820	(3.59)	11 $\frac{1}{2}$	(292)	4	(102)	59	49	134	120	83	9	(2.7)	15	(4.6)			
Radial	900	(56.8)	102	(31.1)	1636	(0.599)	8690	(3.18)	11 $\frac{1}{2}$	(292)	7 $\frac{7}{8}$	(22)	76	47	113	135	44	11	(3.4)	21	(6.1)			
Vortex	1050	(66.2)	150	(45.7)	1323	(0.484)	7088	(2.59)	13	(330)	3 $\frac{3}{4}$	(95)	56	48	137	115	87	16	(4.9)	20	(6.1)			
Radial	1250	(78.9)	154	(46.9)	1415	(0.518)			13	(330)	1 $\frac{1}{32}$	(26)	83	52	123	116	45	11	(3.4)	-	(-)			
Vortex average					1399	(0.512)							50	45	133	120	81							
Radial average					1462	(0.535)							70	50	119	130	51							

<sup>a</sup>Diameter of the largest sphere that will pass through the pump<sup>b</sup>Subscript  $n$  designates values at the best efficiency point



**FIGURE 67** Head characteristics of a typical vortex pump. Curves show approximate characteristics when pumping clear water (in  $\times 2.54 = \text{cm}$ ) (Flowsolve Corporation).



**FIGURE 68** Power characteristics of a typical vortex pump. Curves show approximate characteristics when pumping clear water (in  $\times 2.54 = \text{cm}$ ) (Flowsolve Corporation).

**REFERENCES**

1. Pfleiderer, C. *Die Kreiselpumpen für Flüssigkeiten und Gase*. 5<sup>te</sup> Auflage, Springer-Verlag, 1961.
2. Gülich, J., Favre, J. N., and Denus, K. "An Assessment of Pump Impeller Performance Predictions by 3D-Navier Stokes Calculations." Third International Symposium on Pumping Machinery (S239), ASME Fluids Engineering Division Summer Meeting, Paper No. FEDSM97-3341, June 1997.

3. Rupp, W. E. *High Efficiency Low Specific Speed Centrifugal Pump*. U.S. Patent No. 3,205,828, September 14, 1965.
4. Barske, U. M. "Development of Some Unconventional Centrifugal Pumps." *Proc. Inst. Mech. Eng.*, London, **174**(11):437, 1960.
5. Manson, W. W. "Experience with Inlet Throttled Centrifugal Pumps, Gas Turbine Pumps." *Cavitation in Fluid Machinery*, Symposium Publication, ASME, 1972, pp. 21–27.
6. Wislicenus, C. F. "Critical Considerations on Cavitation Limits of Centrifugal and Axial-Flow Pumps." *Trans ASME*, **78**:1707, 1956.
7. Karassik, I. J., and Carter, R. *Centrifugal Pumps: Selection, Operation and Maintenance*. McGraw-Hill, New York, 1960.
8. Holland, F. A., and Chapman, F. S. *Pumping of Liquids*. Reinhold, New York, 1966.
9. Ippen, A. T. "The Influence of Viscosity on Centrifugal Pump Performance." *Trans. ASME*, **68**(8):823, 1946.
10. Black, H. F., and Jensen, D. N. "Effects of High-Pressure Ring Seals on Pump Rotor Vibrations." ASME Paper No. 71-WA/FF-38, 1971.
11. Wood, C. M., Welna, H., and Lamers, R. P. "Tip-Clearance Effects in Centrifugal Pumps." *Trans. ASME, J. Basic Eng.*, Series D, **89**:932, 1965.
12. Stepanoff, A. J. *Centrifugal and Axial Flow Pumps*, 2nd ed., Krieger Publishing, Malabar, FL, 1957.
13. Rüttschi, K. "Untersuchungen an Spiralgehäusepumpen veraschiedener Schnellläufigkeit," *Schweiz. Arch. Angew. Wiss. Tech.* **17**(2):33, 1951.
14. Stepanoff, A. J. *Pumps and Blowers: Two Phase Flow*. Krieger Publishing, Malabar, FL, 1965.
15. Knapp, R. T. "Recent Investigations of the Mechanics of Cavitation and Cavitation Damage." *Trans. ASME* **77**:1045, 1955.
16. Knapp, R. T. "Cavitation Mechanics and Its Relation to the Design of Hydraulic Equipment." James Clayton, Lecture, *Proc. Inst. Mech. Eng.*, London, Sec. A, **166**:150, 1952.
17. Shutler, N. D., and Mesler, R. B. "A Photographic Study of the Dynamics and Damage Capabilities of Bubbles Collapsing Near Solid Boundaries." *Trans. ASME, J. Basic Eng.*, Series D, **87**:511, 1965.
18. Hickling, R., and Plesset, M. S. "The Collapse of a Spherical Cavity in a Compressible Liquid." Division of Engineering and Applied Sciences, Report No. 85-24, California Institute of Technology, March 1963.
19. Pilarczyk, K., and Rusak, V. "Application of Air Model Testing in the Study of Inlet Flow in Pumps." *Cavitation in Fluid Machinery*, ASME, 1965, p. 91.
20. Plesset, M. S. "Temperature Effects in Cavitation Damage." *Trans. ASME, J. Basic Eng.*, Series D, **94**:559, 1972.
21. Hammitt, F. C. "Observations on Cavitation Damage in a Flowing System." *Trans. ASME, J. Basic Eng.*, Series D, **85**:347 (1963).
22. Preece, C. M., ed. *Treatise on Materials Science and Technology*. Vol. 16, *Erosion*, Academic Press, New York, 1979.
23. Kovats, A. *Design and Performance of Centrifugal and Axial Flow Pumps and Compressors*. Macmillan, New York, 1964.
24. Palgrave, R., and Cooper, P. "Visual Studies of Cavitation in Pumping Machinery." *Proceedings of the Third International Pump Symposium*, Texas A&M University, 1986, pp. 61–68.
25. Cooper, P., Sloteman, D. P., Graf, E., and Vlaming, D. J. "Elimination of Cavitation-Related Instabilities and Damage in High-Energy Pump Impellers." *Proceedings of the Eighth International Pump Users Symposium*, Texas A&M University, 1991, pp. 3–19.

26. Vlaming, D. J. "Optimum Impeller Inlet Geometry for Minimum NPSH Requirements for Centrifugal Pumps." *Pumping Machinery—1989*, ASME, July 1989, pp. 25–29.
27. Hydraulic Institute ANSI/HI 2000 Edition Pump Standards, Hydraulic Institute, Parsippany, NJ [www.pumps.org](http://www.pumps.org).
28. "Centrifugal Pumps." PTC 8.2-1965, American Society of Mechanical Engineers, New York, 1965.
29. Wislicenus, C. F., Watson, R. M., and Karassik, I. J. "Cavitation Characteristics of Centrifugal Pumps Described by Similarity Considerations." *Trans. ASME* **61**:17, 1939; **62**:155, 1940.
30. Stahl, H. A., and Stepanoff, A. J. "Thermodynamic Aspects of Cavitation in Centrifugal Pumps." *Trans. ASME* **78**:1691, 1956.
31. Salemann, V. "Cavitation and NPSH Requirements of Various Liquids." *Trans. ASME, J. Basic Eng.*, Series D, **81**:167, 1959.
32. Stepanoff, A. J. "Cavitation Properties of Liquids." *Trans. ASME, J. Eng. Power*, Series A, **86**:195, 1964.
33. Cooper, P. "Analysis of Single- and Two-Phase Flows in Turbopump Inducers." *Transactions of the ASME*, Series A, Vol. 89, 1967, pp. 577–588.
34. Lazarkiewicz, S., and Troskolanski, A. T. *Impeller Pumps*, Pergamon Press, New York, 1965.
35. Gongwer, C. A. "A Theory of Cavitation Flow in Centrifugal-Pump Impellers." *Trans. ASME*, **63**:29, 1941.
36. Guelich, J. F. *Guidelines for Prevention of Cavitation in Centrifugal Feedpumps*. EPRI CS-6398, 1989.
37. ASTM Standard G-32. *Cavitation Erosion Using Vibratory Apparatus*, American Society for Testing Materials, 1992.
38. Cooper, P., and Antunes, F. F. "Cavitation Damage in Boiler Feed Pumps." *Symposium Proceedings: Power Plant Feed Pumps—The State of the Art*, EPRI CS-3158, July 1983, pp. 2–24 to 2–49.
39. Cooper, P., Sloteman, D. P., and Dussourd, J. L. "Stabilization of the Off-Design Behavior of Centrifugal Pumps and Inducers." *Proceedings of the Second European Congress on Fluid Machinery for the Oil, Petrochemical and Related Industries*, I Mech E Conference Publications, 1984-2, Paper No. C41/84, 1984, pp. 13–20.
40. Stripling, L. B., and Acosta, A. J. "Cavitation in Turbopumps—Part 1." *Transactions of the ASME*, Series D, Vol. 84, 1962, pp. 326–338.
41. Stripling, L. B. "Cavitation in Turbopumps—Part 2." *Transactions of the ASME*, Series D, Vol. 84, 1962, pp. 339–350.
42. Grohmann, M. "Extend Pump Application with Inducers." *Hydrocarbon Processing*, Dec. 1979, p. 121.
43. Doolin, J. H. "Centrifugal Pumps and Entrained Air Problems." *Pump World*, **4**(3), 1978.
44. *Mechanical Engineering*. **93**(6):89, 1971.
45. Kittredge, C. P. "Hydraulic Transients in Centrifugal Pump Systems." *Trans. ASME*, **78**(6):1807, 1956.
46. Parmakian, J. *Waterhammer Analysis*. Prentice-Hall, Englewood Cliffs, NJ, 1955.
47. Streeter, V. L., and Wylie, E. B. *Hydraulic Transients*. McGraw-Hill, New York, 1967.
48. Bergeron, L. *Waterhammer in Hydraulics and Wave Surges in Electricity*. Wiley, New York, 1961.
49. Addison, H. *Centrifugal and Other Rotodynamic Pumps*. 3rd ed. Chapman & Hall, London, 1966.

50. Richardson, C. A. "Economics of Electric Power Pumping." *Allis-Chalmers Elec. Rev.* **9**:20, 1944.
51. Fraser, W. H. "Flow Recirculation in Centrifugal Pumps." *Tenth Turbomachinery Symposium*. Texas A&M University, College Station, TX, 1981, p. 95.
52. Fraser, W. H. "Recirculation in Centrifugal Pumps." *Materials of Construction of Fluid Machinery and Their Relationship to Design and Performance*. ASME, November 1981, pp. 65–86.
53. Gopalakrishnan, S. "A New Method for Computing Minimum Flow." *Proceedings of the Fifth International Pump Users Symposium*. Texas A&M University, 1988, pp. 41–47.
54. "Code of Practice for Pump Efficiency Testing by the Direct Thermodynamic Method." Report 695/27, The Pump Centre, AEA Technology plc, Birchwood Science Park, Warrington WA3 6AT, UK, June 1995.
55. Agostinelli, A., Nobles, D., and Mockridge, C. R. "An Experimental Investigation of Radial Thrust in Centrifugal Pumps." *Trans. ASME, J. Eng. Power*, Series A, **82**:120, 1960.
56. Biheller, H. J. "Radial Force on the Impeller of Centrifugal Pumps with Volute, Semivolute, and Fully Concentric Casings." *Trans. ASME, J. Eng. Power*, Series A, **87**:319, 1965.
57. Donsky, B. "Complete Pump Characteristics and the Effects of Specific Speeds on Hydraulic Transients." *Trans. ASME, J. Basic Eng.*, Series D, **83**:685, 1961.
58. Swanson, W. M. "Complete Characteristic Circle Diagrams for Turbomachinery." *Trans. ASME* **75**:819, 1953.
59. Knapp, R. T. "Complete Characteristics of Centrifugal Pumps and Their Use in the Prediction of Transient Behavior." *Trans. ASME* **59**:683, 1937; **60**:676, 1938.
60. Kovats, A. "Vibration of Vertical Pumps." *Trans. ASME, J. Eng. Power*, Series A, **84**:195, 1962.
61. Bolleter, U., Leibundgut, E., Sturchler, R., and McCloskey, T. "Hydraulic Interaction and Excitation Forces of High Head Pump Impellers." *Pumping Machinery—1989*, FED-Vol. 81, ASME, 1989, pp. 187–193.
62. Kittredge, C. P. "Estimating the Efficiency of Prototype Pumps from Model Tests." *Trans. ASME, J. Eng. Power*, Series A, **90**:129, 301, 1968.
63. Kittredge, C. P. "Centrifugal Pumps Used as Hydraulic Turbines." *Trans. ASME, J. Eng. Power*, Series A, **83**:74, 1961.
64. Acres American Inc. for U.S. Department of Energy, Idaho National Engineering Laboratory, *Small Hydro Plant Development Program*. Vols. I, II, and III, subcontract No. K-1574, Oct. 1980. Available from National Technical Information Service, U.S. Department of Commerce, Springfield, VA 22161.
65. Lawrence, J. D., and Pereira, L. "Innovative Equipment for Small-Scale Hydro Developments: Waterpower '81." *An International Conference on Hydropower, Proceedings*. Vol. II, Washington, DC, June 22–24, 1981, pp. 1622–1639.
66. Cooper, P., and Nelik, L. "Performance of Multi-Stage Radial-Inflow Hydraulic Power Recovery Turbines." Paper presented at ASME Winter Annual Meeting, New Orleans, December 1984.
67. Gopalakrishnan, S. "Power Recovery Turbines for the Process Industry." *Proceedings of the Third International Pump Symposium*, Texas A&M University, 1986, pp. 3–11.
68. Hamkins, C. P., Jeske, H. O., Apfelbacher, R. and Schuster, O. "Pumps as Energy Recovery Turbines With Two-Phase Flow." *Pumping Machinery—1989*, FED-Vol. 81, ASME, 1989, pp. 73–81.
69. Kallas, D. H., and Lichtman, J. Z. "Cavitation Erosion." In *Environmental Effects on Polymeric Materials*, D. V. Rosato and R. T. Schwartz, eds., Wiley-Interscience, New York, 1968, pp. 223–280.



**FURTHER READING**

---

- Anderson, H. H. *Centrifugal Pumps*, Trade and Technical Press, Surrey, England, 1980.
- Brennen, C. E. *Hydrodynamics of Pumps*, Concepts ETI, Inc., and Oxford University Press, 1994.
- Carter, R. "How Much Torque Is Needed to Start Centrifugal Pumps?" *Power* **94**(1):88, 1950.
- Church, A. H. *Centrifugal Pumps and Blowers*. Krieger Publishing, Malabar, FL, 1944.
- Heald, C. C. *Cameron Hydraulic Data*, 18th ed., 1998. Flowserve Corporation, Irving, TX 75039.
- Japikse, D., Marscher, W. D., and Furst, R. B. *Centrifugal Pump Design and Performance*. Concepts ETI, Inc., Wilder, VT, 1997.
- Moody, L. F., and Zowaki, T. "Hydraulic Machinery." 3rd ed., sec. 26 of *Handbook of Applied Hydraulics*. Davis and Sorenson, eds., McGraw-Hill, New York, 1969.
- Spanohake, W. *Centrifugal Pumps, Turbines, and Propellers*. Technology Press, MIT, Cambridge, MA, 1934.
- Wislicenus, C. F. *Fluid Mechanics of Turbomachinery*. Dover, New York, 1965.

## 2.3.2

# CENTRIFUGAL PUMP HYDRAULIC PERFORMANCE AND DIAGNOSTICS

WARREN H. FRASER

Any successful mathematical model of the mechanics of head generation in centrifugal pumps should do more than just make accurate predictions of pump performance; it should also be capable of identifying the cause of operational difficulties. Unlike mechanical malfunctions, which can be detected, analyzed, and corrected, many of the problems caused by hydraulic forces cannot be corrected in the mechanical sense—they are the unavoidable side effects of head generation in a rotating pressure field. For example, a thrust bearing may fail from lack of lubrication, from misalignment, or because an under-rated bearing has been used. These are mechanical failures that can be corrected. A thrust bearing may also fail from a complex pattern of dynamic loading that reflects pressure pulsations of high intensity and a broad spectrum of frequencies during operation at reduced flow. This is an example of a failure from hydraulic causes and can be corrected only by resorting to an oversized bearing or modifying the operation of the pumping system to avoid low-flow operation.

Whenever a consistent correlation can be made between the known dynamics of head generation and operational problems, it is possible to devise a strategy to improve operation and reduce mechanical failures. The most significant problems caused by hydraulic dynamic forces can be listed as follows.

### **CAVITATION**

---

**Cause and Effect** Cavitation is the formation of vapor bubbles in any flow that is subjected to an ambient pressure equal to or less than the vapor pressure of the liquid being pumped. Cavitation damage is the loss of material produced by the collapse of the vapor bubbles against the surfaces of the impeller or casing. Formation of these bubbles cannot occur if the net positive suction head supplied, or *NPSHA*, exceeds the *NPSH* required for

cavitation inception. This *NPSH* inception value is usually significantly higher than the usually mentioned *NPSH* required, or *NPSHR*, which is based on a certain amount of cavitation being present to create a prescribed deviation in pump performance.

**Diagnosis from Pump Operation** Pump operation in the presence of sufficient cavitation activity will reduce both the total head and the output capacity. A steady crackling noise in and around the pump suction indicates cavitation. A random crackling noise with high-intensity knocks indicates suction recirculation but does not indicate a degradation of performance if *NPSHA* is greater than *NPSHR*. The random crackling is the unsteady occurrence of cavitation that generally accompanies suction recirculation, which, in turn, is an unsteady phenomenon.

**Diagnosis from the Visual Examination of Surface Damage** Cavitation damage from inadequate *NPSH* (that is,  $NPSHA < NPSHR$ ) occurs on the low-pressure or the visible surface of the impeller inlet vane.

**Instrumentation** A suction gage or manometer in the pump suction can be used to determine whether the *NPSH* available is equal to or greater than the *NPSH* required from the manufacturer's rating curve (*NPSHR*).

**Corrective Procedures** If additional *NPSH* cannot be supplied, the capacity of the pump should be reduced until the required *NPSH* is equal to or less than the available *NPSH*. If this is not possible, impeller improvement may be necessary. This may be accomplished on some impeller designs by reworking the geometry or impeller surface finish to reduce losses, improve flow characteristics, or increase the flow inlet area (thus lowering impeller inlet velocity). If this is not possible, consideration should be given to replacing the impeller (first stage or suction impeller on multistage pumps) with one of improved suction performance. The pump manufacturer should be consulted to determine the most satisfactory course of action.

## SUCTION AND DISCHARGE RECIRCULATION

---

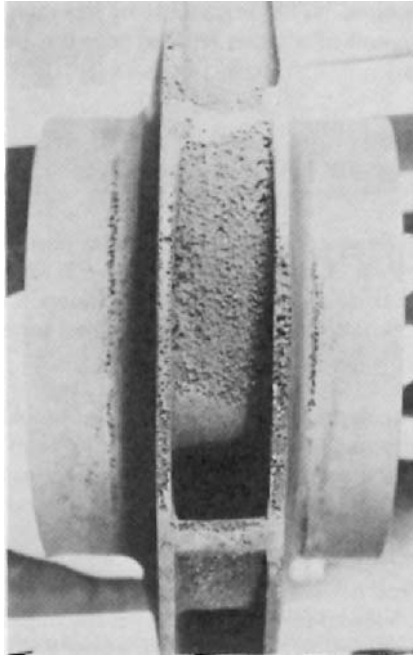
**Cause and Effect** Recirculation occurs at reduced flows and is the reversal of a portion of the flow back through the impeller. Recirculation at the inlet of the impeller is known as *suction recirculation*. Recirculation at the outlet of the impeller is *discharge recirculation*. Suction and discharge recirculation can be very damaging to pump operation and should be avoided for the continuous operation of pumps of significant energy level or pressure rise per stage.

**Diagnosis from Pump Operation** Suction recirculation will produce the previously mentioned loud crackling noise in and around the suction of the pump. Recirculation noise is of greater intensity than the noise from low-*NPSH* cavitation and is a random knocking sound. Discharge recirculation will produce the same characteristic sound as suction recirculation except that the highest intensity is in the discharge volute or diffuser.

**Diagnosis from Visual Examination** Suction and discharge recirculation produce cavitation damage to the pressure side of the impeller vanes. Viewed from the suction of the impeller, the pressure side would be the invisible, or underside, of the vane. Figure 1 shows how a mirror can be used to examine the pressure side of the inlet vane for cavitation damage from suction recirculation. This is unlike cavitation damage from inadequate *NPSH* that occurs on the low pressure surface of the inlet vanes. Damage to the pressure side of the vane from discharge recirculation is shown in Figure 2. Guide vanes in the suction may show cavitation damage from impingement of the backflow from the impeller eye during suction recirculation. Similarly, the casing tongue or diffuser vanes may show cavitation damage on the impeller side from operations in discharge recirculation.



**FIGURE 1** Examining the pressure side of the inlet vanes for suction recirculation damage



**FIGURE 2** Damage to the pressure side of the vane from discharge recirculation

**Instrumentation** The presence of suction or discharge recirculation can be determined by monitoring the pressure pulsations in the suction and in the discharge areas of the casing. Piezoelectric transducers installed as close to the impeller as possible in the suction and in the discharge of the pump can be used to detect pressure pulsations. The data may be analyzed with a spectrum analyzer coupled to an *XY* plotter to produce a record of the

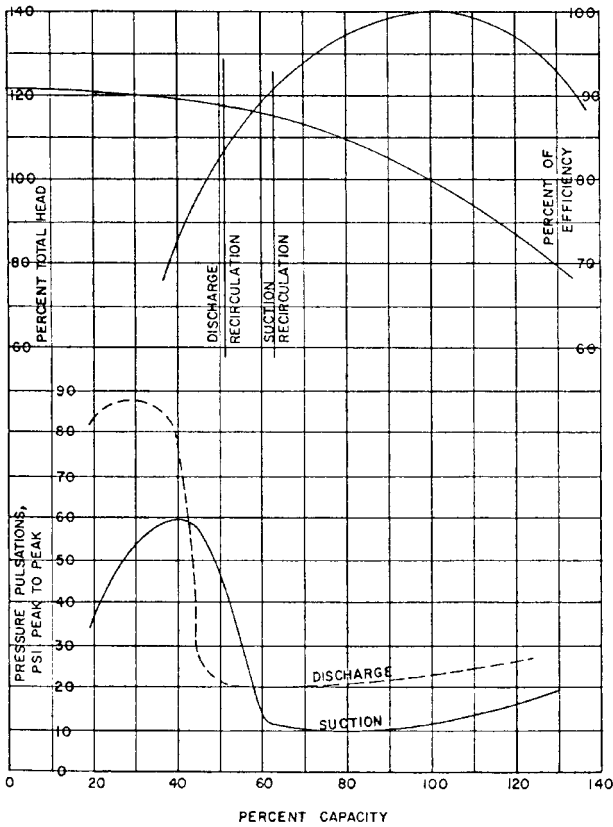


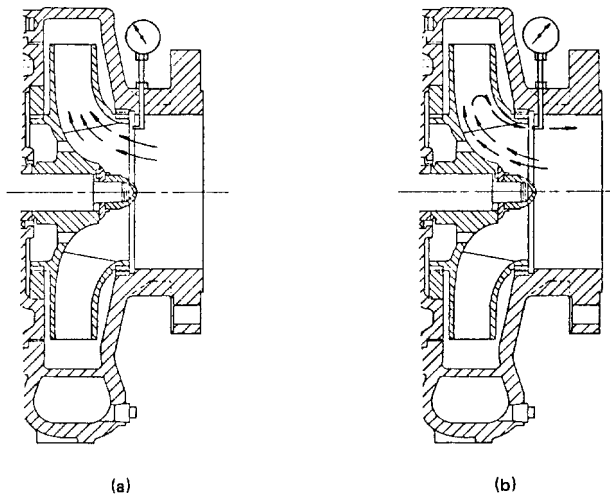
FIGURE 3 Pressure pulsations versus capacity

pressure pulsations versus the frequency for selected flows. Figure 3 shows a typical plot of pressure pulsations versus capacity. As can be seen, a sudden increase in the magnitude of pressure pulsations indicates the onset of recirculation.

The onset of suction recirculation can be determined by an impact head tube (or pitot tube) installed at the impeller eye, as shown in Figure 4. With the tube directed into the eye, the reading in the normal pumping range is the suction head minus the velocity head at the eye. At the point of suction recirculation, however, the flow reversal from the eye impinges on the head tube with a rapid rise in the gage reading.

**Corrective Procedures** Every impeller design has specific recirculation characteristics. These characteristics are inherent in the design and cannot be changed without modifying the design. An analysis of the symptoms associated with recirculation should consider the following as possible corrective procedures:

1. Increase the output capacity of the pump.
2. Install a bypass between the discharge and the suction of the pump.
3. Substitute an improved material for the impeller that is more resistant to cavitation damage.
4. Modify the impeller design.



**FIGURE 4A and B** Installation of the impact head tube to detect suction recirculation during (a) normal flow and (b) recirculation flow

## AXIAL THRUST

**Cause and Effect** Axial thrust is the thrust imposed in the direction of the shaft. It may occur in either the inboard or the outboard direction and is usually composed of a dynamic cyclic component superimposed on a steady-state load in either direction. The dynamic cyclic component increases in the recirculation zone and may impose excessive stresses in the shaft, which could ultimately result in failure from metal fatigue. The static component may impose an excessive load in the thrust bearing, causing unacceptable bearing temperatures. The majority of thrust-bearing failures are caused by fatigue failure of the bearing components from dynamic cyclic axial loads.

**Diagnosis from Pump Operation** High axial loads usually produce high thrust-bearing temperatures and short thrust-bearing life.

### Diagnosis from Visual Examination of Damage

**BEARING DAMAGE** Static thrust in excess of the bearing rating will cause cracking of the balls or rollers and of the race in rolling element bearings and metal scorings of the shoes in tilting-pad bearings. Bearing failure from dynamic loading in excess of the bearing rating will cause fatigue failures of the balls or rollers and race in rolling element bearings.

It is important to differentiate clearly between static load failure and fatigue failure. This can be done by examination of a cross section of the failure zone under the microscope. Fatigue failure from dynamic loading will show a hammering effect caused by points of impact. Fatigue failure from excessive static loading will show metal fatigue without the hammering effect of impact loading.

**SHAFT FAILURE** Shaft failure at the outboard, or unloaded, end of the shaft in multistage or double-suction pumps may be a fatigue failure in tension resulting from the high cyclic stresses induced in the shaft when the pump is operated in the discharge recirculation zone. Axial cyclic stresses can be reduced by increasing the pump output or, if this is not possible, by installing a recirculation line to bypass sufficient flow to move the pump total flow rate beyond the point where damaging discharge recirculation occurs. The pump manufacturer can advise the recommended minimum continuous flow for a specific pump design.

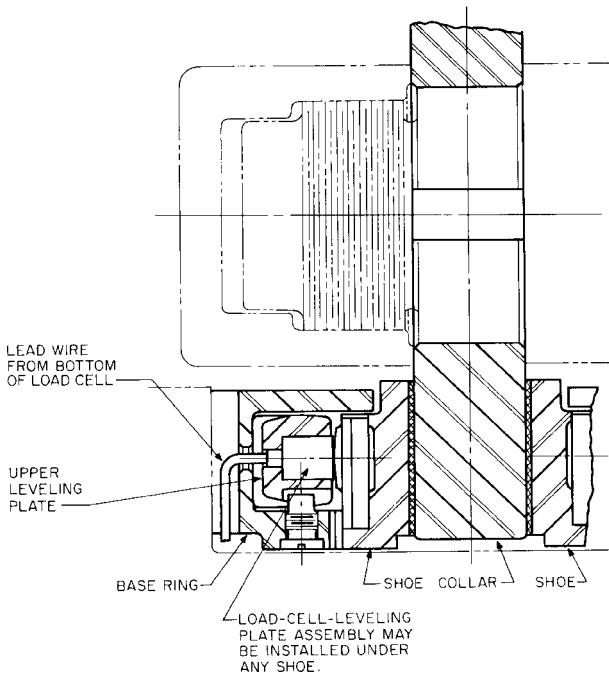


FIGURE 5 Load cell to monitor axial load

**Instrumentation** Displacement-type pickups should be used to determine the axial movement of the shaft relative to the bearing housing. The deflection of the thrust bearing housing can be determined by seismic instruments. Axial loading of the tilting-shoe type of thrust bearing can be monitored by a load cell permanently installed in the leveling plate. A typical installation is shown in Figure 5.

**Corrective Procedures** To determine the most effective procedure to correct axial thrust problems, it is necessary to determine whether the loads are static, dynamic, or a combination of both. If it is a static failure, the thrust can usually be reduced by restoration of the internal clearances. Most shaft and bearing failures from axial thrust, however, are fatigue failures. If the failure is a fatigue failure, the loading can usually be decreased by increasing the capacity of the pump. If this is not possible, shaft failures can be reduced by substituting a shaft material of higher endurance limit. Rolling element bearing failures can be addressed in large, between bearings pumps by substituting a tilting-shoe type of thrust bearing. The high cyclic axial forces are better absorbed in the oil film of the tilting-shoe bearing than in the rolling element bearing.

## RADIAL THRUST

**Cause and Effect** Radial thrust is the thrust imposed on the pump rotor and directed toward the center of rotation of the shaft. The forces are usually composed of a dynamic cyclic component superimposed on a steady-state load. The dynamic cyclic component increases rapidly at low-flow operation when the pump is operating in the recirculation zone. The static load also increases with low- and high-flow operation, with the minimum value at or near the maximum efficiency capacity.

**Diagnosis from Pump Operation** High radial thrust is difficult to determine from pump operation. Persistent packing or mechanical seal problems may indicate excessive shaft deflection from radial loads. As in the case of high axial loads, high radial loads may produce high bearing temperatures with reduced life.

### **Diagnosis from Visual Examination of Damage**

**BEARING DAMAGE** Static radial loads in excess of the bearing rating will cause cracking of the balls or rollers and the races in rolling element bearings. In the case of sleeve bearings, the bearing metal will be worn in one direction only and the journal will be worn uniformly. If the opposite is true (that is, the bearing is worn uniformly and the journal excessively in one direction), the cause of the failure is most likely unbalance or a bent shaft and not excessive bearing loads.

**SHAFT FAILURES** Shaft failures from excessive radial loads usually occur at the midpoint of the shaft span in double-suction or multistage pumps. In the case of end-suction pumps, shaft failures usually occur at the shoulder of the shaft, where the impeller hub joins the shaft sleeve, or at the location of the highest stress concentration, if elsewhere.

**Instrumentation** It is difficult to devise instrumentation to determine excessive radial loading of the shaft and bearings. Temperature rise of the bearings may or may not be symptomatic of excessive radial loading. High bearing temperatures may occur from misalignment, inadequate lubrication, or excessive axial loading of the thrust bearing. These causes should be eliminated before concluding that the radial loads are excessive.

**Corrective Procedures** Most bearing and shaft failures caused by excessive radial loads occur when the pump operates at low flow rates. Radial loads can be reduced by operating the pump at higher capacities or by installing a bypass from the pump discharge back to the pump suction or suction source. For pumps handling water, the life of the shaft may be extended by substituting a martensitic stainless (13% chrome) steel shaft for carbon steel. If there are signs of corrosion as well as fatigue failure, an austenitic stainless steel shaft may also be considered. Physical properties should be evaluated carefully, as the endurance limit of the 300 series steels may be lower than that of chrome steels in fresh water. For liquids other than water, the endurance limit of the shaft material in the liquid being pumped may be a significant determining factor in the life of the shaft in the presence of high dynamic loading.

## **PRESSURE PULSATIONS**

---

**Cause and Effect** Pressure pulsations are present in both the suction and the discharge of any centrifugal pump. The magnitude and frequencies of the pulsations depend upon the design of the pump, the head produced by the pump, the response of the suction and discharge piping, and the point of operation of the pump on its characteristic curve. The observed frequencies in the discharge may be the running frequency, the vane passing frequency, or multiples of each. In addition, random frequencies with pressure pulsations higher than either the rotating or the vane passing frequencies have been observed. The cause of these random frequency pulsations is sometimes difficult to determine. System resonance, acoustic behavior, eddies from valves and poor upstream piping, and so on, are sometimes involved. However, such random pressure pulsations should not be dismissed as spurious or irrelevant data in any analysis of symptomatic operational problems.

The observed frequencies in the pump suction are much lower than in the discharge. Typical frequencies are in the order of 5 to 25 cycles/s, and they do not appear to bear any direct relation to the rotational speed of the pump or the vane passing frequency.

**Diagnosis from Pump Operation** In most pumping installations of 435 lb/in<sup>2</sup> (3MPa) [that is, 1000 ft (305 m) of head in water] or less of head per stage, there is little outward



manifestation of pressure pulsations during normal pumping operation. Other than for specialized applications, such as white water pumps for paper machines (where the discharge pressure pulsations may affect the quality of the paper) or quiet pumps in marine service, there are few external symptoms of internal pressure pulsations. For high-head pumps, however, suction and discharge pressure pulsations may cause instability of pump controls, vibration of suction and discharge piping, and high levels of pump noise.

**Diagnosis from Visual Examination of Damage** In the case of high-head pumps, any failure of internal pressure-containing members should be investigated with consideration given to the possibility that the failures are fatigue failures from internal pressure pulsations. Examination of the fracture will determine whether the failure is a fatigue failure or not. Fatigue failures may have one or more origins. Characteristic markings, known as striations, are often present on the fracture surface. Metallurgical examination of the fracture surface will also disclose striations on a microscopic scale. These markings represent growth of the crack front under cyclic stress.

If it is a fatigue failure, the cause can usually be traced to high cyclic stress induced in the pressure-containing member from high-frequency pressure pulsations.

**Instrumentation** Pressure pulsations are usually measured with piezoelectric pressure transducers and recorded as peak-to-peak pressure pulsations over a broad frequency band. Recorded on tape or strip charts, a spectral analysis may be performed for any operating condition.

**Corrective Procedures** A spectral analysis of the pressure pulsations at the suction and at the discharge of the pump is necessary before a strategy for corrective procedures can be developed. After the spectral analysis is available, problems associated with pressure pulsations can usually be reduced by implementing the procedures shown in Table 1.

**TABLE 1** Corrective procedures for various problems

Problem	Corrective procedure
1. Vibration of suction or discharge piping	<ol style="list-style-type: none"> <li>a. Search for responsive resonant frequencies in the piping or supports. If any part of the system responds to the frequency of the pressure pulsations, alter the system to shift the resonant frequencies.</li> <li>b. If possible, increase the output of the pump by changing the mode of operation or by installing a bypass from the discharge to the suction of the pump.</li> <li>c. If the piping responds to the vane passing frequency of the pump, the impellers can be replaced with a unit containing either one fewer or one more vane.</li> </ol>
2. Instability of pump controls	<ol style="list-style-type: none"> <li>a. If possible, increase the output of the pump by changing the mode of operation or by installing a bypass from the discharge to the suction of the pump.</li> <li>b. Install acoustical filters to reduce the magnitude of the pressure pulsations.</li> </ol>
3. Fatigue failure of internal pressure-containing components of the pump from pressure pulsations	<ol style="list-style-type: none"> <li>a. If possible, increase the output of the pump by changing the mode of operation or by installing a bypass from the discharge to the suction of the pump.</li> <li>b. Redesign the failed components to reduce the induced cyclic stresses to below the endurance limit of the material.</li> <li>c. If the spectral analysis shows that the maximum pressure pulsations correspond to the vane passing frequency of the impeller, the impeller can be replaced by one having either one fewer or one more vane of the same design.</li> </ol>

# 2.3.3 CENTRIFUGAL PUMP MECHANICAL PERFORMANCE, INSTRUMENTATION, AND DIAGNOSTICS

CHARLES JACKSON  
JAMES H. INGRAM

## **MECHANICAL PERFORMANCE**

---

The mechanical performance of a pump would imply only the rotating mechanical masses, with no consideration given to hydraulic (process) effects. The rotating masses (impellers, sleeves, nuts, coupling, bearings, seals, and so on) can be examined as pure mechanics. A person concerned with mechanical performance should be intimately familiar with pump design, construction, and maintenance to be successful.

In discussing the mechanical performance of centrifugal pumps, two examples will be used. The first will be a horizontal, 500-hp (373-kW), single-stage (overhung impeller) American Petroleum Institute (API) process pump. The second will be a six-stage, horizontal, 1000-hp (746-kW), multistage boiler-feed pump.

Normally, the rotor dynamics will involve (a) a review of the shaft stiffness of the bearings and structure, (b) a mass model of the rotor, and (c) a critical speed analysis with mode shapes of the rotor or shaft.

## **SINGLE STAGE PUMP**

---

An  $8 \times 6 \times 13$  pump is operating on water at 3550 rpm with a design flow of 2500 gpm (567 m<sup>3</sup>/h) at 600 ft (183 m) total head, 1.0 sp. gr., requiring approximately 500 hp (373 kW). The pump operated extremely rough, and the bearings and bearing housing failed. The impeller weighs 61.4 lb (27.9 kg).

If the impeller is fitted on the shaft with an eccentricity of 0.002 in (0.051 mm), a calculated centrifugal force  $F_e$  of 44 lb (196 N) would cause a deflection of 0.0026 in (0.066 mm) from

$$y = wl^3/3EI$$

where  $w$  = weight (force) of impeller, lb ( $N$ )  
 $l$  = length of overhang, in (m)  
 $E$  = modulus of elasticity, lb/in<sup>2</sup> ( $N/m^2$  or Pa)  
 $I$  = shaft section moment of inertia, in<sup>4</sup> (mm<sup>4</sup>)

This pump has a 5212 line bearing and tandem mounted (DB) 7311DB angular contact thrust bearings (40° contact angle). An extremely loose fit of the radial bearing in the bearing housing could cause the outer race to spin, which could cause a vibration equal to twice the rotation frequency. Interference fitting could lead to radial bearings' accepting thrust (for which many are not designed) from thermal expansion of the shaft or from the thrust bearing.

**Frequencies Generated** The following data and definitions are needed to compute the frequencies generated by defective bearings<sup>1</sup>:

rpm = revolutions per minute  
 rps = revolutions per second  
 FTF = fundamental train frequency, Hz  
 BPF<sub>I</sub> = ball passing frequency of inner race, Hz  
 BPF<sub>O</sub> = ball passing frequency of outer race, Hz  
 BSF = ball spin frequency, Hz  
 Bd = ball or roller diameter, in (mm)  
 Nb = number of balls or rollers  
 Pd = pitch diameter, in (mm)  
 Ø = contact angle

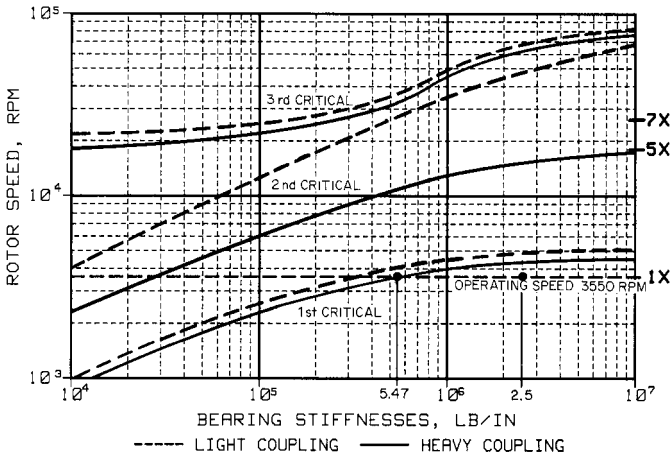
The formulas are

$$\begin{aligned} \text{rps} &= \frac{\text{rpm}}{60} \\ \text{FTF} &= \frac{\text{rps}}{2} \left( 1 - \frac{Bd}{Pd} \cos \vartheta \right) \\ \text{BPF}_1 &= \left( \frac{Nb}{2} \text{rps} \right) \left( 1 + \frac{Bd}{Pd} \cos \vartheta \right) \\ \text{BPF}_O &= \left( \frac{Nb}{2} \text{rps} \right) \left( 1 - \frac{Bd}{Pd} \cos \vartheta \right) \\ \text{BSF} &= \left( \frac{Pd}{2Bd} \text{rps} \right) \left[ 1 - \left( \frac{Bd}{Pd} \right)^2 \cos^2 \vartheta \right] \end{aligned}$$

The pitch diameter is the diameter measured across the bearing from ball or roller center to ball or roller center. The contact angle is measured from a line perpendicular to the shaft to the point at which the balls or rollers contact the race. The contact angle of a deep groove ball bearing is zero.

It is necessary to distinguish between the ball frequency and the impeller vane passing frequency, which is 17,750 cpm (5 vanes  $\times$  3550 rpm  $\times$  1 casing cutwater) for this example. The mode shape of the pump shaft is conical (pivotal) in the first mode of a cantilevered shaft mount. The stiffness map of the rotor looks like that shown in Figure 1.

This pump has two design faults, as can be seen from the stiffness map. The first is that an excessively large coupling is used. This heavy overhung mass at the coupling forces the first shaft resonance to be very near the pump operating speed. Normally, the shaft in this type of pump is considered to be "rigid," that is, operating safely below the first undamped shaft resonance. In this case, the pump is affected by two negatively additive errors. The



**FIGURE 1** Undamped critical speed map of single-stage overhung pump, comparing normal and heavy coupling weights (lb/in × 175 = N/m)

**TABLE 1** Logic of spring equivalent stiffness  $K_e$

SPRING	ELECTRICAL RESISTOR EQUIV ANALOG	EXAMPLES OF VARIATIONS ( $K_e$ )		
$1/K_e = \frac{1}{K_b} + \frac{1}{K_s}$	$1/R_e = \frac{1}{R_b} + \frac{1}{R_s}$	$K_e = 91k \text{ lb/in}$	$K_e = 83k \text{ lb/in}$	$K_e = 50k \text{ lb/in}$

$K_b$  = STIFFNESS OF BEARING, lb/in (N/m)      N/m = 175 X lb/in  
 $K_s$  = STIFFNESS OF SUPPORT, lb/in (N/m)  
 $K_e$  = EQUIVALENT STIFFNESS

NOTE: SPRINGS IN PARALLEL SIMPLY ADD, AS DOES ELECTRICAL RESISTANCE IN SERIES:  $K_e = K_b + K_s$

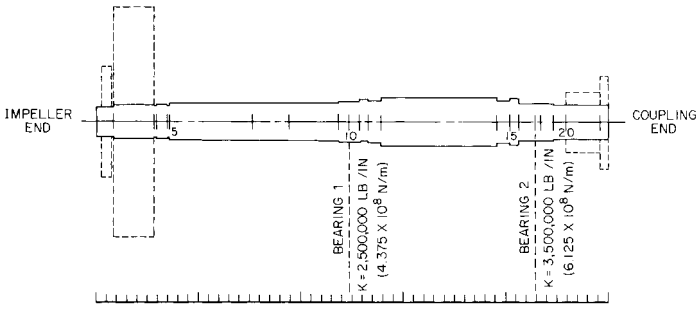
heavy mass coupling effect is compounded by a weak baseplate that is not properly grouted, leaving a void under the pump supports. In rotor (shaft) supports, two spring supports in series reciprocally add, similar to electric resistors in parallel (Table 1).

The effective stiffness is

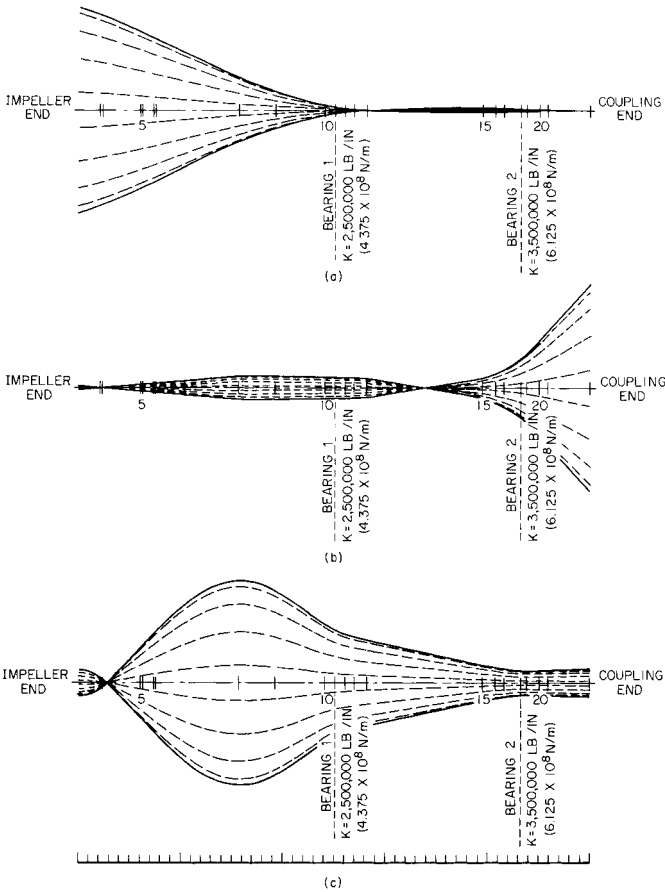
$$K_e = \frac{1}{1/K_b + 1/K_s}$$

If the bearing stiffness  $K_b$  is  $2.5 \times 10^6 \text{ lb/in}$  ( $4.4 \times 10^6 \text{ N/m}$ ) and the support stiffness  $K_s$  is low; that is,  $7.0 \times 10^5 \text{ lb/in}$  ( $1.2 \times 10^5 \text{ N/m}$ ), the effective stiffness is  $5.47 \times 10^5 \text{ lb/in}$  ( $9.57 \times 10^7 \text{ N/m}$ ), which moves the first mode resonance from 4300 cpm to 3550 cpm, which is the running speed of the pump.

The mode shapes of the rotor are shown in Figures 3 and 4. An animated display is used to better show the rotor gyrations in synchronous whirl. The first modes are shown with a

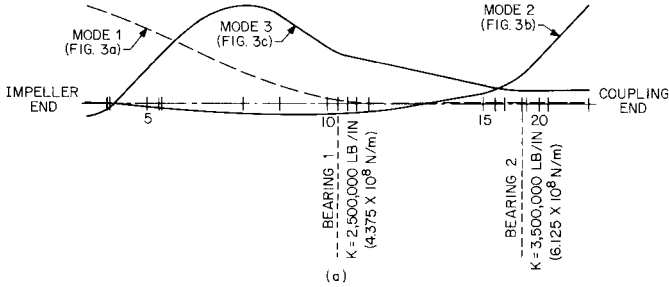


**FIGURE 2** Rotor cross section of single-stage overhung pump with normal coupling weight. Rotor weight = 110.4 lb (50kg); rotor length = 30.3 in (77.0 cm); number of stations = 22; number of bearings = 2

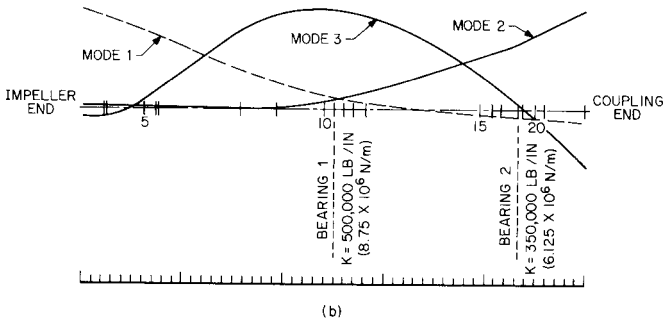


**FIGURE 3** First, second, and third resonate animated mode shapes of single-stage overhung pump with light coupling of 15 lb (6.8 kg) and rigid foundation. Rotor weight = 110.4 lb (50 kg); rotor length = 30.3 in (77.0 cm); number of stations = 22; number of bearings = 2. (a) Mode 1: frequency = 4717 cpm; (b) mode 2: frequency = 53,482 cpm; (c) mode 3: frequency = 67,522 cpm

No. UNITS	CRITICAL SPEED		WMODE, lb	ITMODE, lb/in <sup>2</sup>	KMODE, lb/in	DIM. STRAIN ENERGY	
	rpm	(Hz)				USHAFT	UBEARING
1	4717	(79)	57.0	1.84E-01	3.60E+04	91	9
2	53482	(891)	6.0	3.59E-01	4.90E+05	36	64
3	67522	(1125)	9.8	6.42E-01	1.27E+06	42	58



No. UNITS	CRITICAL SPEED		WMODE, lb	ITMODE, lb/in <sup>2</sup>	KMODE, lb/in	DIM. STRAIN ENERGY	
	rpm	(Hz)				USHAFT	UBEARING
1	4085	(68)	58.0	1.81E-01	2.75E+04	59	41
2	21251	(354)	13.8	3.50E-01	1.76E+05	10	90
3	40036	(667)	17.1	1.34E-00	7.78E+05	37	63



**FIGURE 4** Synchronous critical speed summary with first three mode shapes of a single-stage overhung pump with light coupling of 15 lb (6.8 kg) and rigid or flexible foundation. Rotor weight = 110.4 lb (50 kg); rotor length = 30.3 in (77.0 cm); number of stations = 22; number of bearings = 2. (a) Rigid support, modes 1, 2, and 3 respectively: 4717, 58,482, and 67,522 rpm; (b) flexible support, modes 1, 2, and 3 respectively: 4085, 21,251, and 40,036 rpm. (lb  $\times$  0.454 = kg; lb/in  $\times$  175 = N/m)

lighter, normal, and correct coupling (15 lb; 6.8 kg). Figure 2 shows the mathematical model of this pump with the impeller at station 2, the radial bearing at station 11 at  $2.5 \times 10^6$  lb/in ( $4.4 \times 10^8$  N/m) stiffness, the outboard thrust/radial bearing at station 18 at  $3.5 \times 10^6$  lb/in ( $6.1 \times 10^8$  N/m) and the coupling at station 21.

Figure 3a, obtained from a finite element computer analysis of the mathematical model in Figure 1, shows the first mode with a rotor weight of 110.4 lb (50 kg), a rotor length of 30.3 in (77.0 cm), and a first mode undamped resonance (critical) of 4717 cpm. This is a pivotal mode, with 100% of the normalized motion at the impeller end. Any motion at the antifriction bearings is greatly restrained.

Figure 3b shows the second resonance mode, at 53,482 cpm, which is not to be encountered. The coupling motion is now the greatest motion.

Figure 3c shows the third mode, at 67,522 cpm.

Figure 4a shows an overlay of all three modes with a summary of the criticals, the modal mass, and the relative strain energy (91) in the shaft at station 10 (impeller side of radial bearing). A lesser strain energy is at the radial bearing (station 11).

Figure 4b summarizes what happens to critical speed modes if either a more *flexible* bearing or a soft structure is provided intentionally or unintentionally. Also note that the criticals are lowered significantly and the strain energy is transferred more from the shaft into the bearings; that is, strain values under the *U-shaft* column are less than under *U-bearing* column. The first critical is 4085 cpm at a pump speed of 3550 rpm (+15%). A 15% margin of separation may be close enough to excite (cause a rise in vibration) the rotor if the resonance response envelope is too wide. However, this is unlikely on antifriction bearings (spiky/narrow response), but possible on sleeve bearings (low/broad response).

Figure 5a is a summary which shows the response of a rigid support and an *excessively heavy* (62 lb = 28 kg) coupling, which is as heavy as the impeller. Note that the first mode is again only slightly above the operating speed; that is, 4279 cpm compared with 3550 (+21%). The bearing stiffness is assumed to be the controlling stiffness. Many assume that the structure or base stiffness is one order above the bearing stiffness ( $K_s = 10K_b$ ). This assumption that the bearing stiffness is the controlling stiffness variable is often a very poor assumption. The larger the pump size, the more this is true. That is why an  $8 \times 6 \times 13$  pump was used as an example.

Further, the second mode, at 15,865 cpm, is in an area where the blade passing frequency ( $5 \times 3550 = 17,750$  cpm) can easily excite this mode, given little variation in support stiffness. Figure 5b is a summary sheet that best illustrates the problem:

- The baseplate was improperly installed and grouted.
- The elastomeric coupling designed for low-duty, low-speed, and torsional damping was *too heavy*; that is, too much overhung weight.

Note that the first critical is in sympathy with the pump operating speed, which becomes intolerable with the operating time *limited* to one to two days, due to bearing failures.

The stiffness on antifriction bearings was determined from a program written by M. E. Leader of Monsanto, using values projected by an article written by F. F. Garguilo, DuPont.<sup>2</sup> The correction consisted of converting the 62-lb (28-kg) coupling to a 15-lb (6.8-kg) series dry flex disk-type coupling and stiffening the support by flushing the baseplate cavity with a degreasing fluid and pressure injection of epoxy to fill the baseplate voids.

It should be remembered that the blade passing frequencies will normally be the strongest exciting force. On this pump, the frequency is five times running speed (five vanes times each cutwater). Because there are two cutwaters, there can also be a frequency at 10 times running speed. The  $5 \times$  frequency is shown on Figure 1. Also, this  $5 \times$  frequency excitation could excite the second mode because the second mode critical could fall anywhere between the solid and dashed lines, depending on baseplate stiffness.

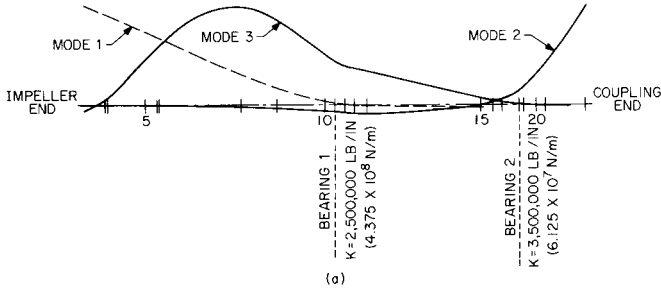
The instruments used in diagnosing this problem were force-effective seismic sensors (velocity or piezoelectric accelerometers). They are preferred for pumps, particularly those with antifriction bearings.

## MULTISTAGE PUMP EXAMPLE

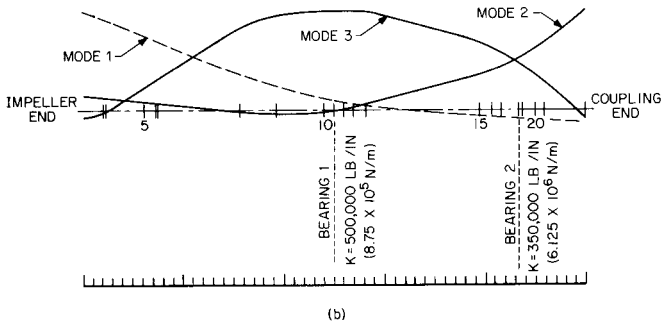
---

To show the mechanical rotor variations, a six-stage boiler-feed pump with a design capacity of 1250 gpm (284 m<sup>3</sup>/h), 2200 ft (670 m) total head, and driven by a 1000-hp (746-kW), two-pole motor has been selected. This pump utilizes interstage bushings as support bearings to the rotor. The contribution of these bushings as bearings will probably be less than might be assumed.

No. UNITS	CRITICAL SPEED		WMODE, lb	ITMODE, lb/in <sup>2</sup>	KMODE, lb/in	DIM. STRAIN ENERGY	
	rpm	(Hz)				USHAFT	UBEARING
1	4279	(71)	65.2	1.80E-01	3.39E+04	91	9
2	15865	(264)	53.3	3.28E-01	3.81E+05	73	27
3	64970	(1083)	8.9	6.54E-01	1.07E+06	51	49



No. UNITS	CRITICAL SPEED		WMODE, lb	ITMODE, lb/in <sup>2</sup>	KMODE, lb/in	DIM. STRAIN ENERGY	
	rpm	(Hz)				USHAFT	UBEARING
1	3580	(60)	66.6	1.79E-01	2.43E+04	61	39
2	9339	(156)	59.6	3.47E-01	1.48E+05	35	65
3	35365	(589)	22.0	7.01E-01	7.82E+05	25	75

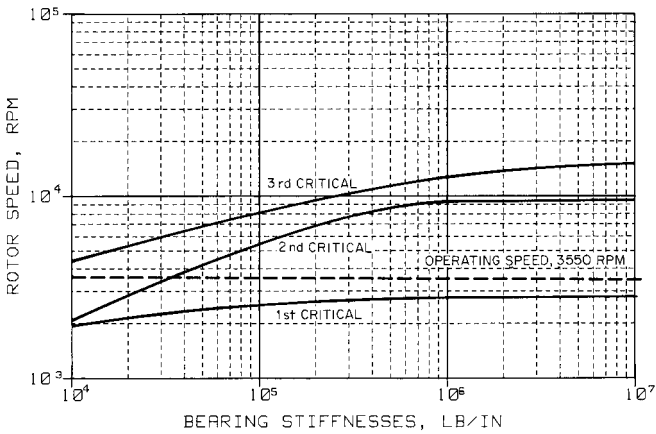


**FIGURE 5** Synchronous critical speed summary with first three mode shapes of a single-stage overhung pump with heavy coupling of 62 lb (28 kg) and rigid foundation. Rotor weight = 157.4 lb (71.4 kg); rotor length = 30.3 in (77.0 cm); number of stations = 22; number of bearings = 2. (a) Rigid support, modes 1, 2, and 3 respectively: 4279, 15,865, and 64,970 cpm; (b) flexible support, modes 1, 2, and 3 respectively: 3580, 9339, and 35,565 cpm. (lb  $\times$  0.454 = kg; lb/in  $\times$  175 = N/m)

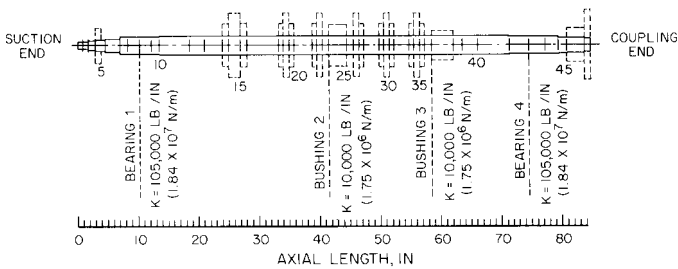
Pressure or seal leakage control bushings contribute rotor support if they are long. The hot feedwater has very low viscosity and little damping. The bearing stiffness will be relative to the eccentricity ratio of the shaft in the bushings. An eccentricity ratio of unity (maximum) implies that the shaft is rubbing directly on its bushing.

The impeller weight is increased by the water trapped in each impeller. Many pump manufacturers improperly list pump undamped critical speeds from *dry* pump data or calculations. The bushings, labyrinths, and wear rings all contribute to the actual critical speed. Also, bearing housing resonances are more common than expected.





**FIGURE 6** Undamped critical speed map of multistage boiler-feed pump with plain journal bearings (lb/in  $\times$  175 = N/m)



**FIGURE 7** Rotor cross-section of multistage high-pressure boiler-feed pump with plain journal bearings. Rotor weight = 377.7 lb (171.3 kg), rotor length = 84.6 in (215 cm); number of stations = 47, number of bearings or bushings = 4 (in  $\times$  2.54 = cm)

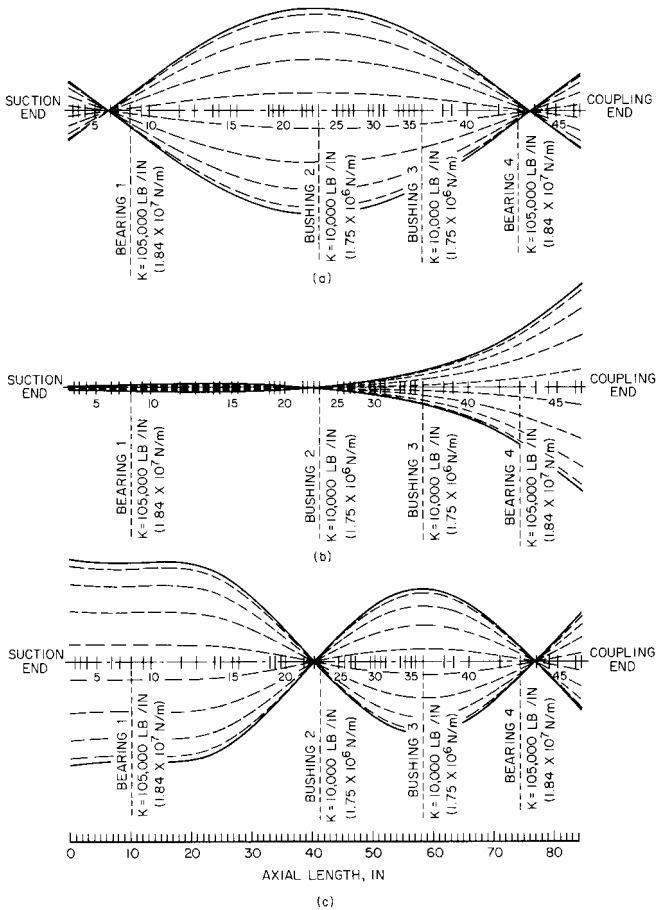
Figures 6 to 9 illustrate it in the same fashion as the previous example the design audit of a steam-turbine-driven,  $4 \times 8 \times 10\frac{1}{2}$ , six-stage, boiler-feed pump using hydrodynamic radial and thrust bearings. No problems were experienced with this pump.

A more complete listing of data from analysis is shown with an added breakdown of the rotor model and the output of the first, second, and third resonant modes. The first critical (rotor resonance) is now a cylindrical mode and not a conical mode, as previously seen for the overhung impeller of the single-stage process pump.

## ALIGNMENT OF PUMPS AND DRIVERS

Outside of serious unbalance of pump components, there is no single contributor of poor mechanical performance more significant than poor alignment. Incorrect alignment between a pump and its driver can cause

- Extreme heat in couplings
- Extreme wear in gear couplings and fatigue in dry element couplings



**FIGURE 8** First, second, and third resonant animated mode shapes of multistage high-pressure boiler-feed pump with plain journal bearings. Rotor weight = 377.7 lb (171.3 kg); rotor length = 84.6 in (215 cm); number of stations = 47; number of bearings or bushings = 4. (a) Mode 1: frequency = 2614 cpm; (b) mode 2: frequency = 5223 cpm; (c) modes: frequency = 8134 rpm. (in  $\times 2.54 = \text{cm}$ )

- Cracked shafts and totally failed shafts, with failure due to reverse bending fatigue transverse to the shaft axis initiating at the change of section between the large end of the coupling hub taper and the shaft
- Preload on bearings (evident by an elliptical and flattened orbit resembling a deflated beach ball); pure asymmetry of vertical and horizontal vibration can be misleading because the bearing spring constants could vary greatly in the  $k_{yy}$  (vertical) and the  $k_{xx}$  (horizontal) axis.
- Bearing failures plus thrust transmission through the coupling, which can be totally locked (axial vibration checks across the coupling; that is, at each adjacent machine, will generally confirm this condition)

Significant changes in the cold nonrunning alignment of a pump and driver can take place if the temperature rise in each machine is different and if the piping imposes forces on the pump.

No. UNITS	CRITICAL SPEED		WMODE, lb	ITMODE, lb/in <sup>2</sup>	KMODE, lb/in	DIM. STRAIN ENERGY	
	rpm	(Hz)				USHAFT	UBEARING
1	2614	(44)	200.6	8.23E-01	3.89E+04	51	49
2	5223	(87)	51.2	2.40E-01	3.96E+04	17	83
3	8134	(134)	127.8	1.38E-00	2.40E+05	46	54

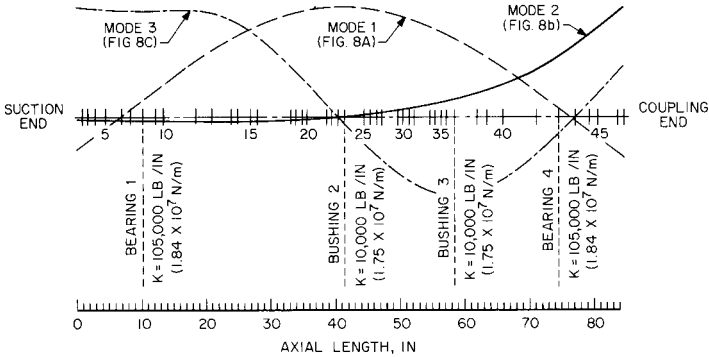


FIGURE 9 First three critical speed mode shapes of multistage high-speed boiler-feed pump superimposed (in  $\times 2.54 = \text{cm}$ )

Therefore, alignment under actual operating conditions must be predicted or, if unknown, confirmed by instrumentation. In either case, an allowance must be made in the initial cold alignment to compensate for changes in alignment from cold idle to hot running.

There are several techniques for measuring cold and hot alignment. The cold alignment is generally measured by either face and rim (Figure 10) or reverse dial indicator (Figure 11) methods.

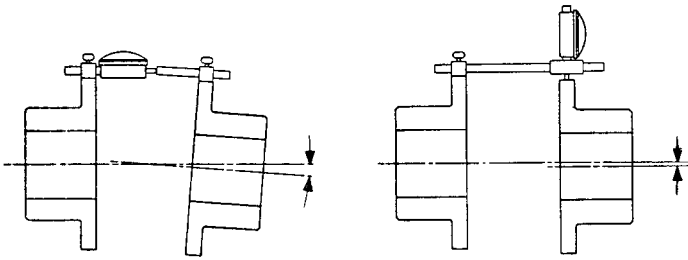
The face and rim method has a sensitivity advantage when the diameter of a coupling exceeds the indicator span of reverse indicator bracket tooling. This is rare, as the pump will generally have a spacer coupling and the reach of the reverse indicators can be increased by clamping onto the shaft behind each coupling half. The face and rim method would also have an advantage if either the driver or the gear could not be rotated, as it seems unlikely that the pump could not be rotated. In order to compensate for the measuring surface's not being circular or smooth, both shafts should be rotated together when using this method.

### Disadvantages of Face and Rim Method

1. Diameters of the rim must be true (circular) and smooth and the face reading surface must be flat and smooth, unless both shafts are rotated together.
2. The driver and pump cannot float axially while a reading is being taken or an error will be introduced into the face (angular) reading. (A fixed axial stop will assist in reducing errors.)

**Reverse Dial Procedure for Measuring Alignment (Hot or Cold)** Several procedures have been suggested by various people to estimate or actually measure alignment while a pump is running at operating temperature. Some techniques are

1. Shutdown after temperatures have stabilized for "hot check" by dial indicators
2. Optical measurements cold to hot (A. J. Campbell, Compressor Engineering Corp., Houston)
3. Dodd bars (DynAlign) technique (B. Dodd, Chevron<sup>3</sup>)



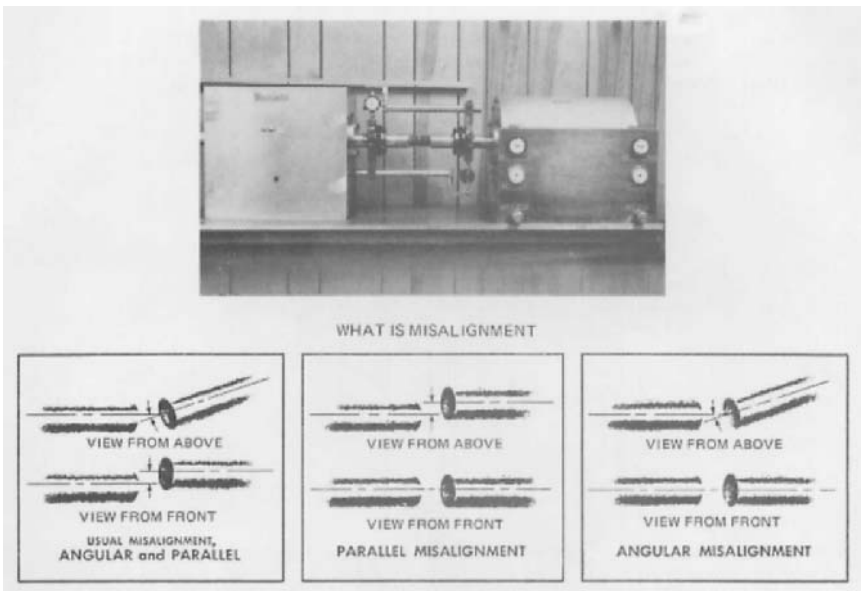
**Check for Angular Misalignment** Dial indicator measures maximum longitudinal variation in hub spacing through 360° rotation.

1. Attach dial indicator to hub, as with a hose clamp; rotate 360° to locate point of minimum reading on dial; and then rotate body or face of indicator so the zero reading lines up with pointer.
2. Rotate both half couplings together 360°. Watch indicator for misalignment reading.
3. Driver and driven units will be lined up when dial indicator reading comes within maximum allowable variation for that coupling style. Refer to specific installation instruction sheet for the coupling being installed. Note: If both shafts cannot be rotated together, connect dial indicator to the shaft that is rotated.

**Check for Parallel Misalignment** Dial indicator measures displacement of one shaft center line from the other.

4. Reset pointer to zero and repeat operations 1 and 2 when either driven unit or driver is moved during aligning trials.
5. Check for parallel misalignment as shown. Move or shim units so parallel misalignment is brought within the maximum allowable variations for the coupling style.
6. Rotate couplings several revolutions to make sure no "end-wise creep" in connected shafts is measured.
7. Tighten all lockouts or capscrews.
8. Recheck and tighten all locknuts or capscrews after several hours of operation.

**FIGURE 10** Face and rim dial indicator method (Courtesy Rexnord)



**FIGURE 11** Model used for training machinist in the use of reverse dial indicator technique for alignment of machine shafts. Misalignment can be measured as parallel or angular offset.

4. Acculign bench mark gauges (I. Essinger, Shell Oil)
5. Water-cooled probe stands (C. Jackson, Monsanto)
6. Instrumented coupling (for example, Indikon)

Refer to Reference 4 for more specific information on the above techniques.

After measurements have been made and actual misalignment is determined for the hot running condition of the pump, the next step is to calculate the alignment correction required between machines to bring them into alignment during operation. Trial-and-error methods should be discouraged. Plotting actual shaft positions to scale allows one to graphically measure the required cold alignment corrections. Other methods—for example, those that can best be carried out with the aid of a programmable calculator—quickly and accurately calculate vertical, horizontal, inboard or outboard changes in machine positions to accomplish the correct cold alignment. See Reference 11 for a calculator program for both reverse dial and face and rim methods.

Offered here are a graphical procedure and an example for obtaining the desired alignment between a pump and driver for a case where the thermal growth has been estimated and a calculated cold alignment is desired to achieve the final alignment during operation.

The example is illustrated in Figure 12. Consider a steam-turbine-driven boiler-feed pump that has the following heat rise predictions by the manufacturers: steam end 0.002 in (0.051 mm), exhaust end 0.012 in (0.305 mm), pump inboard support 0.006 in

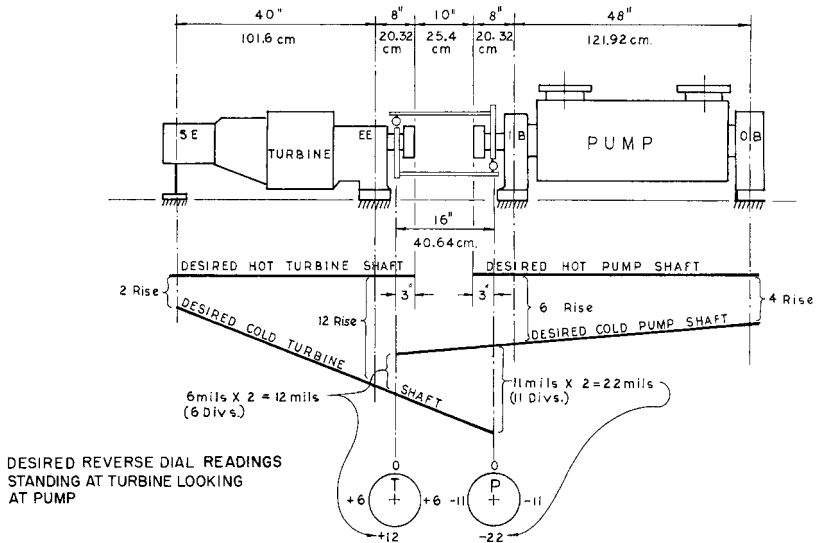


FIGURE 12 Alignment example of a turbine-driven boiler-feed pump with heat-rise data from the manufacturers plotted to calculate the desired cold alignment

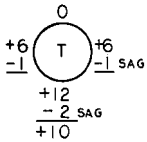


FIGURE 13 Desired dial indicator readings corrected for indicator bar sag

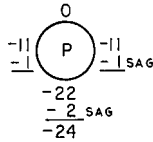


FIGURE 14 Actual alignment readings

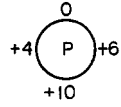
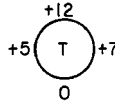


FIGURE 15 Dial readings corrected to position zero at top

FIGURE 16 Actual alignment readings corrected for indicator bar sag

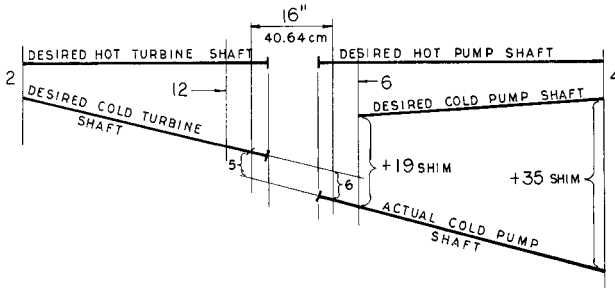
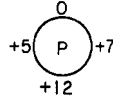
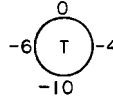
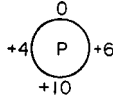
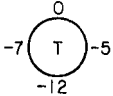


FIGURE 17 Plot of absolute vertical shaft positions. It can be seen from the graph that a 0.019-in (0.483-mm) shim is required to raise the inboard end of the pump and a 0.035-in (0.889-mm) shim is required to raise the outboard end of the pump to compensate properly for thermal growth

(0.152 mm), and outboard bearing 0.004 in (0.102 mm). The horizontal length is laid on a graph with 1 div. = 1 in (25.4 mm). The vertical movement plots are laid out with 1 div. = 0.001 in (1 mil; 0.0254 mm).

Based on 0.001-in (0.0254-mm) sag (see Figure 19), the field readings needed to meet the above absolute requirements are shown in Figure 13.

The actual cold alignment is checked, and the reverse dial readings are as recorded in Figure 14. There are 0.125-in (3.175-mm) shims under all support feet. It is decided to move the pump rather than the turbine, and therefore the correct cold position of the pump must be calculated.

To correct the turbine dial readings to position zero at the top, simply add  $-12$  to all four turbine readings (Figure 15). To correct for sag (see Figure 19 for explanation), *subtract* 1 from the left and right readings and 2 from the bottom reading (Figure 16). Finally, plot the absolute shaft positions on graph paper, leaving the turbine “in place,” so to speak, thereby determining two points across the 16-in (40.64-cm) indicator span to define *where* the pump shaft lies with respect to the turbine (Figure 17).

To plot the horizontal corrections, reduce the final horizontal readings *only* to zero on the least numerical reading, by adding 4 to the turbine readings and  $-5$  to the pump reading, as shown in Figure 18.

Dial indicator readings can be in metric units and the scale in centimeters rather than inches. A scale of between 500:1 and 1000:1 is suggested. A 1000:1 scale is in use here (horizontal scale equals 1000 times vertical scale).

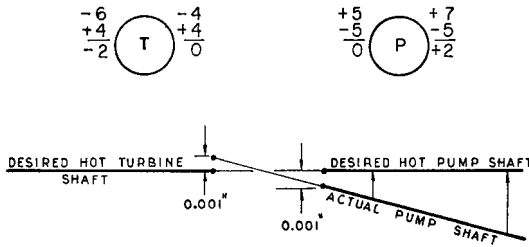
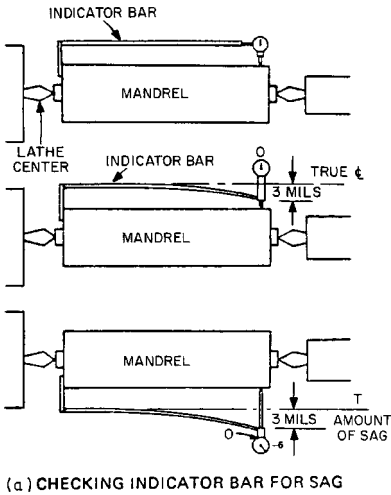


FIGURE 18 Required horizontal corrections

As shown in Figure 12, the driver and pump are purposely misaligned so actual operating temperatures will put the two shafts within acceptable limits. The acceptable limits for pump final alignment are 0.001 in/in (0.025 mm/mm) of coupling flex plane separation. If a spacer coupling is 5 in (13 cm) between flex planes on the flexible coupling, the shafts must be within 0.005 in (0.127 mm) vertical or horizontal offset. Pure angular misalignment in one plane is not desired, as it reduces the tolerance by 2:1 for gear couplings (dry coupling would have severe fatigue in one flex plane). The above limits should be reduced by one-half.

### INSTALLATION SUGGESTIONS AND USE OF DIAL INDICATORS

1. Nonferrous shim packs should be installed under all feet of the pump and driver, particularly when installing a new pump. The amount should be 0.125 to 0.250 in (3.175 to 6.35 mm) in no more than three pieces to start; for example, one 0.125-in (3.175 mm) and two 0.0625-in (1.59-mm) full shims of stainless steel.
2. Motors have four feet generally, and any “soft foot” should be compensated first. A soft foot is one that is shorter than the other two or three feet, a condition that puts a twist or strain in the equipment. Simply place a dial indicator stem vertically against the motor foot and release the hold-down bolts sequentially around the unit, recording and retightening at each step. If a 0.002-in (0.050-mm) spring-up occurs on three feet, for example, and 0.006 in (0.152 mm) occurs on the fourth foot, add 0.004 in (0.10 mm) of shim to the fourth foot, eliminating the soft foot.
3. Provide low-sag tooling to reach over the coupling (coupling left in place) for reverse indicator alignment. A 0.001- to 0.0015-in (0.025- to 0.038-mm) sag is easy to accomplish on indicator reach bars.
4. Let the indicator indicate on its own bracket or bracket pin, thus preventing any poor surface condition of shaft or coupling from contributing to poor measurements.
5. Support the dial indicator weight on the motor or pump shaft so it does not contribute to “reach bar” sag.
6. Do not overlook the fact that many times one can clamp to the shaft behind each coupling hub and obtain more span and therefore better accuracy.
7. Record all data looking the *same* way down the unit; that is, top east, bottom, west or top, north bottom, south or top, right bottom, left. It is suggested that the driver-pump always be viewed from the driver end.
8. Turn the shafts in the direction they normally turn and approach the 90° points in a precise manner (do not back up and introduce backlash errors). Turning in the normal direction is good training because, on gear units, it reduces helix angle lift errors.



(a) CHECKING INDICATOR BAR FOR SAG

(b) UNCORRECTED INDICATOR READINGS

(c) CORRECTED INDICATOR READINGS

(d) CORRECTING READING FOR SAG

Indicator bar sag can be determined by firmly affixing it to a sag-free shaft mandrel, usually 4-in (10-cm) diameter or larger, dependent on length. The mandrel may be supported between lathe centers, mounted on knife edges, or held and rotated by hand. With the indicator bar positioned on top of the mandrel, the sag of the bar will be down toward the mandrel. Set indicator face to read zero at this position. By zeroing the indicator, you have erred the indicator by the amount of the sag. Rotate the mandrel 180° (indicator at bottom position). The indicator bar will sag away from the mandrel; hence the indicator reading will be twice the actual bar sag and will read negative as shown in (a).

$$\left( \frac{\text{TIR}}{2} = \text{Sag} \right)$$

FIGURE 19A through D Illustrative procedure to determine the amount of sag in an indicator bar (bracket) (Courtesy Reference 3)

Once the indicator bar sag is determined, it should be permanently stamped on the bar. This true sag must be accounted for when determining sweep readings.

To correct your sweep readings for sag, subtract twice the amount of true sag from the bottom reading (B) and correct the side readings (R & L) by subtracting the amount of the sag.

Sweep reading for an 8 mil vertical offset before making correction for a 3 mil indicator bar sag would be as shown in (b)

As shown in (c) and (d), correct sweep readings for indicator bar sag (amount of sag was 3 mils):

$$\begin{aligned} B &= (+10) - (-6) \text{ or } +16 \\ R &= (+5) - (-3) \text{ or } +8 \\ L &= (+5) - (-3) \text{ or } +8 \end{aligned}$$

9. If the motor can be turned down from the end opposite the end from which the measurements are taken, do so. Regardless, always release the strap wrench or spanner bar before recording each  $\frac{1}{4}$ -point reading.
10. Obtain center zero dial indicators or revolution counter indicators or carefully note all indicator movements with a mirror to assure, for example, that 0.090 in was not really -0.010 in. The algebraic sum of horizontal and vertical readings should be near equal.

## INSTRUMENTS FOR VIBRATION ANALYSIS

One fact about end-suction and between-bearing pumps is that external visual evidence of mechanical problems is very limited. Only three gauges for mechanical trouble exist: temperature, vibration, and sound.



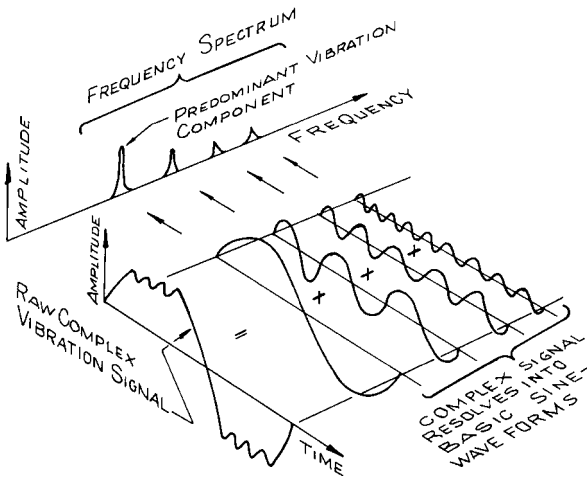


FIGURE 20 Complex vibration signal resolves into sine wave spectrum

It is normal for a machine to vibrate at some level; such vibrations are caused by manufacturing defects, design limits of the pump, casting irregularities, less than optimum application, and a maintenance/installation problem. When the velocity vibration level starts to increase 0.1 in/s (2.5 mm/s) zero to peak (0-P) above the "as new installed level," the vibration should be analyzed to determine the possible sources of the mechanical and/or hydraulic problem. Several mechanical and/or hydraulic problems may be producing, for instance, the  $1\times$  running speed frequency vibration. The key in using vibration to define the mechanical and/or hydraulic problems is to determine the *frequency* at which the vibration occurs. Vibration *amplitude* is also an important factor because it indicates the severity of the vibration. Field vibration data are normally a complex vibration waveform. By using a tunable analyzer, the complex vibration signal, as shown in Figure 20, can be filtered or tuned into its basic frequency components; that is, all complex signals are summations of the harmonics and subharmonics  $1\times$ ,  $0.5\times$ ,  $6\times$ ,  $30\times$ , and so on. By comparing these filtered components of the complexed vibration signal with an analysis chart and some common-sense experience, probable causes of the vibration can be listed.

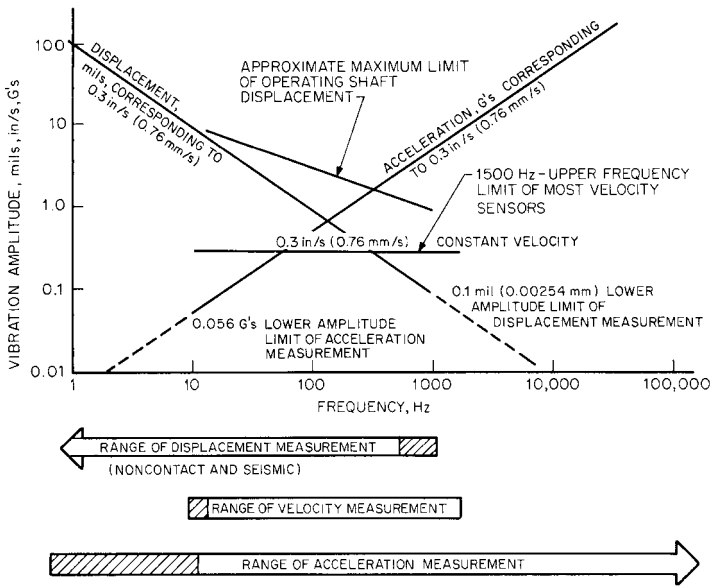
The first step toward resolving the vibration problem is to convert the mechanical movement to an equivalent electrical signal so it can be filtered and measured.

Often used analyzer systems are

1. A turbine ac-battery-powered analyzer with strobe light, providing amplitude, frequency, and phase. A plotter accessory can also be attached for copies of the data.
2. A small battery-powered, internally driven, tunable analyzer with a built-in plotter using an accelerometer or velocity sensor.
3. A spectrum analyzer, ac powered, that receives the signal directly from a vibration transducer or the recorded signal from a battery-powered four-channel FM/AM cassette tape recorder.

For startup or where the problem is tougher, one can add

1. Eight-channel FM tape recorder
2. Four-channel oscilloscope with blanking and time display
3. Tracking filter displaying revolutions per minute, amplitude, and phase, capable of tracking runup/run-down data



**FIGURE 21** Limitations on machinery vibration analysis systems and transducers (mils  $\times$  0.0254 = mm; in/s  $\times$  25.4 = mm/s) (Reference 10)

Provisions should be made for the use of all types of sensors, as there are advantages in each. As more complex problems continue to appear, tunable analyzers with a sensor are not just a requirement but a necessity in any maintenance reliability program. The choice of a displacement sensor (eddy current probe), velocity or seismic sensor, or an accelerometer depends on the frequency range to be analyzed and the type of pumping equipment. There is no one vibration sensor for all jobs.

Of the three types of vibration measurements, acceleration and displacement are dependent on frequency and velocity is independent of frequency. Most engineers and technicians select a measurement that is independent of frequency for a datum to judge the general health of new and used pumps. With the exception of low-speed pumps and motors, 1750 rpm or less, unfiltered velocity and filtered velocity are used for most basic data. Figure 21 shows the frequency relationships (log) versus output (log) of three different measurement sensors with reference to a constant velocity of 0.3 in/s (7.6 mm/s). The figure gives an overview of present sensor limits and shows that each sensor is like a window through which portions of the frequency spectrum may be observed. The figure also shows that the accelerometer is the choice sensor at high frequency because it measures the square of the frequency. The advantage of displacement at low frequencies is due to its high output; the disadvantage of displacement at high frequencies is that the output signal will disappear into the background noise of most measuring systems.

One should not confuse the measurement parameters (displacement, velocity, and acceleration) with the sensors (eddy current probes for displacement, velocity sensors, and accelerometers). The basic relationship of these measurement parameters with commonly used units are shown on a simple sine wave in Figure 22.

Although the velocity sensor is not necessarily the *best* all-around type of sensor, it does have the advantage of high self-generating output (up to 1000 ft [300 m] of cable), can be mounted in any position, and is influenced only slightly (less than 5%) by transverse sensitivity (side forces). The disadvantages are that the output signal below 600 cpm is significantly nonlinear but can be corrected, the accuracy is limited at  $\pm 8\%$  to 1000 Hz, and

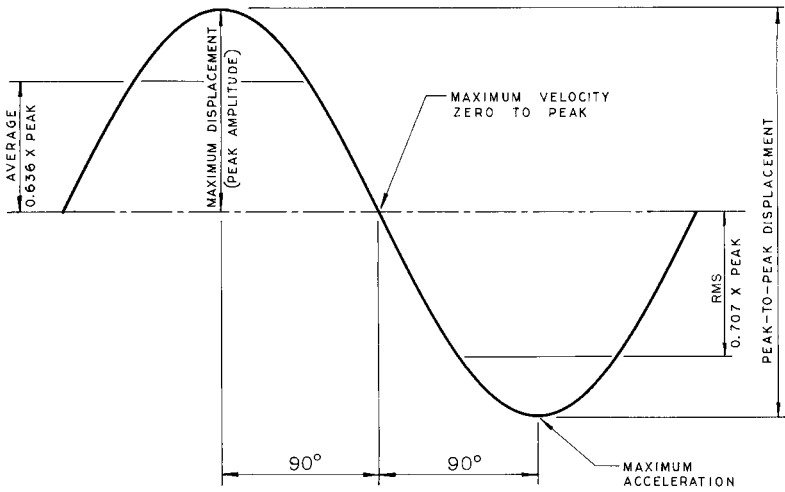


FIGURE 22 Basic relationship of measured parameters with a simple sinusoidal vibration

the sensor will most likely have problems in one to two years when mounted in field applications where vibration is high, especially vane passing frequencies.

The piezoelectric accelerometer is a very light and compact sensor that measures vibration using a mass mounted on a piezoelectric crystal. Its output is low and requires a charge amplifier in the lead even with very short leads. The accelerometer is small and can be mounted virtually anywhere; it has a 1 to 3% influence factor from transverse side forces. A good rule of thumb on the usable frequency range is one-fifth to one-third of the resonant frequency. The disadvantages are that the sensor is sensitive to mounting torque, although stud mount is the best method to mount accelerometers. A lot of data are produced, of which some may be the data from an excited accelerometer resonance or cable noise. An impedance matching device can be built into the accelerometer for use at temperatures below 250°F (120°C), and cable noise can be greatly reduced with the voltage and charge sensitivity greatly improved; for example, 100 mV/g and 50 to 100 pC/g (where  $g$  = number of accelerations of gravity). For higher temperatures, the accelerometer will need a separate charge amplifier and may need heat insulation, such as MICA wafers (refer to API 678, dated 1981).

Most so-called ultrasonic analyzers use the accelerometer as a structural microphone. Many have chosen a carrier frequency in the megahertz range to improve the signal-to-noise ratio and make characteristic high-frequency patterns. Most of these systems are still in the development stage.

**Techniques for Taking Data** The second most important part of a vibration analysis program is the type of data taken and the techniques used to take the data. The purpose of taking vibration data on a pump is to either perform an analysis because someone noticed a noise or increased vibration level, or as a part of a periodic preventative maintenance program. It has been proven from experience that the velocity measurement is the best method for determining acceptable levels of centrifugal pump vibration. This is not to say that displacement and acceleration are not measures of vibration severity; they are, but it is necessary to know the frequency of the vibration. Displacement is preferred by a few for frequencies less than 6000 cpm. Accelerometers matched with analyzers can be purchased with signal integration that will give reliable readings in velocity in the 3000- to 60,000-cpm range. For readings above 60,000 cpm, the sensor would generally be an accelerometer reading in  $g$ 's, peak or integrated to read velocity zero to peak or 0-P.

Vibration amplitude is an important parameter because it indicates the approximate severity of the dynamic stress levels in the pump. Experience has shown that the shaft

bearings and seal will probably fail in a pump with a velocity reading of 0.5 in/s (13 mm/s) 0-P. Also, catastrophic failures will probably occur when a pump is at 1 in/s (2.5 mm/s) 0-P. Pumps with velocity readings of 0.05 to 0.15 in/s (1.3 to 3.8 mm/s) 0-P, will perform well mechanically. Vibration readings are taken in the horizontal and vertical planes on the bearing housing of horizontal-shaft pumps.

To have a worthwhile maintenance reliability program with pumps, vibration readings must be recorded regularly (that is, monthly). This can range from a trend plotting of unfiltered vibration to a full vibration analysis using a real-time analyzer to generate the frequency spectrum. A standard method used by many companies consists of taping pump vibrations with a battery-powered cassette recorder using a velocity sensor. Readings can then be processed through a real-time analyzer and recorded on an *XY*Y' plotter. The best application of this method is during startup and repair evaluation.

As an alternate method, a spectrum analyzer/plotter that produces a spectrum on a 4 in × 6 in (10 mm × 15 mm) card with a frequency plot versus amplitude can be used. This procedure has in some installations detected and corrected 95% of the mechanical problems before failure. Experience has shown that had unfiltered displacement readings been taken, only 60 to 70% of the mechanical problems would have been observed. During these recordings, emphasis should be placed on the change in vibration levels, which is a better indication of a mechanical problem than absolute vibration.

One of the best pieces of data available for the pump's equipment file is a vibration record taken during the manufacturer's test or during water batching or commissioning. It is advisable to request a witness performance test on key or critical pumps. The purpose of this test is to assure mechanical reliability *along with* performance.

The manufacturer should be asked about the availability and type of vibration analysis equipment and sensors. Regardless of the instruments used, the vibration data sheet for the tested pump should have a sketch of where all vibration points were taken. The manufacturer should also supply a complete mechanical description of the number of impeller vanes, number of casing volute cutwaters or diffuser vanes, type of coupling, length of coupling spacer, and so on.

There are several different methods for taking periodic vibration data on pumps:

1. Using a handheld battery-powered velocity probe/readout, a machinist or operator logs unfiltered readings taken at one or two points on the bearing housing. When the reading reaches 0.3 to 0.5 in/s (8 to 13 mm/s) 0-P, the pump is pulled for maintenance. Readings are usually taken every two weeks.
2. Vibration points in the vertical, horizontal, and axial directions are recorded on a tabulated chart in unfiltered and filtered velocity at the various peak amplitudes, using a battery-powered tunable analyzer with a velocity sensor.
3. Vibrations in the vertical, horizontal, and axial direction are taken at each bearing, using a velocity sensor. The signal is recorded on a tape recorder, preferably a battery-powered FM/AM cassette. These data are then processed through a real-time analyzer. A spectrum hard copy is made on an *XY*Y' plotter of velocity versus frequency.
4. Key vibration points are fed directly from a velocity sensor or an accelerometer/charge amplifier through a long extension cable to a safe area, where a real-time analyzer processes the signal into a velocity versus frequency spectrum or a *g*'s (acceleration) versus frequency spectrum. Hard copies for records are made on a *XY*Y' plotter. This method requires two technicians with radios.

The most accurate are methods 3 and 4. The most costly to run in workerhours per point is method 2. The least accurate is, of course, method 1, but it is a popular screening technique.

**Use of Vibration Sensors** The use of a handheld velocity sensor with an aluminum extension rod or a light-duty vise grip with the probe mounted on the top of the grip has produced some high and misleading vibration readings because of extension resonances. For instance, the vise grip should not be used because of a 5000-cpm resonance. A 9-in (23 cm) long by  $\frac{3}{8}$ -in (0.95-cm) diameter extension to the velocity pickup should not be used above 16,000 cpm. The approximate axial natural frequency in cycles per minute for a rod extension from the probe, in tension and compression, can be expressed as

in USCS units 
$$f_n = 188\sqrt{\frac{AE}{WL}}$$

in SI units 
$$f_n = 946\sqrt{\frac{AE}{WL}}$$

where  $W$  = pickup weight (force), lb (N)

$L$  = length of rod, in (m)

$A$  = cross-sectional area of rod, in<sup>2</sup> (m<sup>2</sup>)

$E$  = modulus of elasticity of rod, ° lb/in<sup>2</sup> (kPa)

Use of attachments above these listed frequencies will produce a higher amplitude.

The best and simplest method of holding a velocity probe to a pump is a two-bar magnetic holder on the end of a velocity probe. Proper cleaning and some paint removal are generally necessary for good attachment. Periodic wiping of the magnetic bar to remove iron filings is also necessary. After mounting the probe, give it a light twist and a rocking motion; if it twists easily or rocks, change locations or reclean the surface. This location should be marked and future readings taken on the same spot; otherwise, the trend plots will vary.

If there is a concern about an extension or magnetic holder resonance, test this by holding the sensor, without the extension or magnetic holder, directly to a reasonably flat spot and noting any differences. Holding the sensor on a flat spot is generally safe up to 60,000 cpm.

When measuring vibration on an electric motor, there is always the possibility of false readings at 60 and/or 120 Hz due to electrical induction by the motor. This can be checked by two methods:

1. Hold the sensor by its cord and move it toward the motor, noting any increase in amplitude.
2. Using a two-channel oscilloscope, trigger the filtered signal against line voltage. In-phase signals mean the vibration is electrically induced.

For field use, one usually does not have to contend with temperatures above 250°F (120°C) direct to the sensor; thus, accelerometers with built-in impedance matching devices can be used and 100 mV/g voltage sensitivities can be obtained and transmitted 300 ft (90 m) if necessary. If the frequency range is low, and it is for pumps, a charge sensitivity in the order of 100 pC/g can also be obtained.

**Techniques for Taking Preliminary Vibration Readings** Some key points to remember before you start your analysis of the vibration problem:

1. Do not reach a decision on what the problem is before you record and analyze the data. By deciding too quickly what the problem is, you will most likely neglect other important factors.
2. Before you take the data, take time to review maintenance logs, talk with the area mechanic and operator, and make notes on the following:
  - a. Are there any unusual sounds (cavitation, bearings, and so on)?
  - b. Is there any movement in the discharge pressure gage?
  - c. What is the direction of rotation?
  - d. Are the flush and cooling lines lined up properly?
  - e. Is there any movement in the coupling shim pack?
  - f. Are there any foundation cracks?
  - g. Are pipe supports functioning properly?
  - h. Has a suction screen been installed?

<sup>°</sup>For aluminum,  $E = 10.3 \times 10^6$  lb/in<sup>2</sup> ( $71 \times 10^6$  kPa). For steel,  $E = 30 \times 10^6$  lb/in<sup>2</sup> ( $207 \times 10^6$  kPa)

- i. What is the magnitude of the liquid velocity in the suction line?
- j. Is the automatic oiler level adjusted correctly?
- k. Where is the pump being operated?
  - l. What are the flow, suction, and discharge pressure?
- m. Is the pump's minimum flow bypass system in service?
- n. Has the process changed?
- o. What is the suction valve stem orientation?
- p. Have there been any color changes in the paint?
- q. Are there any loose parts, including the coupling guard?
- r. Determine the color and feel of the oil (if possible).
- s. What is the bearing housing temperature?
- t. How is the coupling guard attached (attachment to the bearing housing is poor practice)?

You will be surprised how much this information aids in an analysis. Example: you record a high 1× in the radial plane, low values of 2× and 5×, and several high-frequency components at about 0.15 in/s (4 mm/s) O-P. The 1× could be a bent shaft, loose coupling, plugged impeller, bad coupling unbalance, upper and lower case halves misaligned, and a whole list of running frequencies symptoms. During your review of maintenance logs, you noted that the impeller had been replaced because there had been distillation column tray part damage. The next questions you should ask are, "Did maintenance reinstall the suction screen?" (if not, another tray part may have lodged in the impeller) and, "Was the impeller rebalanced after it was trimmed from maximum diameter?"

- 3. Do not try to interpret partial vibration readings for someone looking over your shoulder before you have even taken all the readings. Sit down in a quiet place with your notes on installation and maintenance, a symptoms list, and a severity chart and then make the analysis. Analysis is not a simple task, but with some experience you will build confidence and it will become second nature.

## VIBRATION DIAGNOSTICS

---

**Analysis Symptoms** The vibration severity chart and vibration identification chart are guides, but experience, a set of procedures, and study of the literature will make diagnostics easier. To be effective, one must be thoroughly familiar with the machinery's internal construction, installation, and basic control system. Both mechanical and hydraulic mechanisms can produce symptoms of vibration.

The vibration analysis symptoms, or vibration severity criteria, chart has taken on many forms since the Rathbone chart of 1939. Perhaps the most widely used symptoms chart in the turbo-machinery field today is the original paper published by Sohre.<sup>5</sup> A condensation and revision of the original paper is shown in Table 2. Although this chart includes some symptoms that will never appear in pumps, it is one of the better references for vibration analysis. The way the table gives percentages of cases showing the symptoms for the causes listed is unique. As one learns to use the chart and modifies it with experience, a good diagnostic tool will be developed.

A good guide for unfiltered bearing cap velocity limits on field installed pumps is given in Table 3. A guide for shop testing new and rebuilt pumps is given in Reference 6.

**Comments on Table 2** In the following comments, the numbers correspond to "Cause of vibration" in Table 2.

- 1. Long, high-speed rotors often require field balancing at full speed to make adjustments for rotor deflection and final support conditions. Corrections can be made at balancing rings or at coupling bolts.

**TABLE 2** Vibration analysis symptoms

Cause of vibration	Predominant frequencies											Vert.	Hor.
	0-40%	40-50%	50-100%	1X running frequency	2X running frequency	Higher multiples	½ running frequency	¼ running frequency	Lower multiples	Odd frequency	Very high frequency		
1. Initial unbalance .....	..	..	..	90	5	5	..	..	..	..	..	40	50
2. Permanent bow or lost rotor parts (vanes) .....	..	..	..	90	5	5	..	..	..	..	..	↓	↓
3. Temporary rotor bow .....	..	..	..	90	5	5	..	..	..	..	..		
4. Casing distortion {	Temporary .....			10	80	5	5	..	..	..	..		
	Permanent .....			10	80	5	5	..	..	..	..		
5. Foundation distortion .....	..	20	..	50	20	..	..	..	..	10	..	↓	↓
6. Seal rub .....	10	10	10	20	10	10	..	..	10	10	10	30	40
7. Rotor rub, axial .....	20			30	10	10	..	..	10	10	10	30	40
8. Misalignment .....	..	..	..	40	50	10	..	..	..	..	..	20	30
9. Piping forces .....	..	..	..	40	50	10	..	..	..	..	..	20	30
10. Journal & bearing eccentricity .....	..	..	..	80	20	..	..	..	..	..	..	40	50
11. Bearing damage .....	20			40	20	..	..	..	..	..	20	30	40
12. Bearing & support excited vibration (oil whirls, etc.) ..	10	70	..	..	..	..	10	10	..	..	..	40	50
13. Unequal bearing stiffness horizontal-vertical .....	..	..	..	..	80	20	..	..	..	..	..	40	50
14. Thrust bearing damage .....	90				..	..	..	..	..	..	10	20	30
Insufficient tightness in assembly of: .....	Predominant frequency will show at lowest critical or resonant frequency											..	..
15. Rotor (shrink fits) ..	40	40	10	..	..	..	..	..	..	10	..	40	50
16. Bearing liner .....	90			..	..	..	..	..	..	10	..	40	50
17. Bearing cases .....	90			..	..	..	..	..	..	10	..	40	50
18. Casing & support .....	50			..	..	..	..	..	..	50	..	40	50
19. Gear inaccuracy .....	..	..	..	..	..	20	..	..	..	20	60	30	50
20. Coupling inaccuracy or damage .....	10	20	10	20	30	10	..	..	..	..	..	30	40

Numbers indicate percent of cases showing previous symptoms, for causes listed in vertical column at left.

Source: *The Practical Vibration Primer* by Charles Jackson. Copyright (c) 1979 by Gulf Publishing Company, Houston, Texas. Used with permission. All rights reserved.

TABLE 2 Continued.

Direction and location of predominant amplitude							Amplitude response to speed variation during vibration-test runs										Cause	
Axial	Shaft	Bearings	Casing	Foundation	Piping	Coupling	Coming up				Slowing down							
							Stays same	Increases	Decreases	Peaks	Comes suddenly	Drops out suddenly	Stays same	Increases	Decreases	Comes suddenly		Drops out suddenly
																	Stays same	
10	90	10	..	..	..	..	..	100	..	Peaks at critical	..	..	..	..	100	..	..	1
			..	..	..	..	..	100	..		..	..	..	..	..	..	..	2
			..	..	..	..	30	60	5		5	..	30	5	50	5	10	3
			..	..	..	..	30	50	5		5	10	30	5	50	5	10	4
			..	..	..	..	40	60	..		..	..	40	..	60	..	..	
	40	30	10	10	10	..	20	80	..		..	..	20	..	80	..	..	5
30	80	10	10	..	..	..	10	70	..		10	10	10	..	70	10	10	6
30	70	10	20	..	..	..	10	40	10		20	20	10	..	50	20	20	7
50	80	10	10	..	..	..	20	30	10		20	20	20	..	40	20	20	8
50	80	10	10	..	..	..	20	40	..		20	20	20	..	40	20	20	9
10	90	10	..	..	..	..	40	50	10		..	..	40	10	50	..	..	10
30	70	20	10	..	..	..	10	50	10		20	10	10	10	50	10	20	11
10	50	20	20	20	..	..	..	10	..	..	90	..	..	..	10	..	90	12
10	40	30	30	..	..	..	..	40	..	50	10	..	..	..	40	..	10	13
50	60	20	20	..	..	..	20	50	10	..	10	10	20	10	50	10	10	14
10	60	20	20	..	..	..	..	..	..	..	90	10	..	..	..	10	90	15
10	80	10	10	..	..	..	..	..	..	..	90	10	..	..	..	10	90	16
10	70	20	10	..	..	..	..	..	..	..	90	10	..	..	..	10	90	17
10	50	20	30	..	..	..	..	..	..	..	90	10	..	..	..	10	90	18
20	80	10	10	..	..	..	20	20	20	20	10	10	20	20	20	10	10	19
30	70	20	..	..	..	10	10	20	..	20	Loose sleeve, friction or dirt 40 in teeth 10		10	..	20	10	40	20



TABLE 2 Continued.

Cause of vibration	Predominant frequencies											Vert.	Hor.	
	0-40%	40-50%	50-100%	1X running frequency	2X running frequency	Higher multiples	½ running frequency	¼ running frequency	Lower multiples	Odd frequency	Very high frequency			
21. Rotor & bearing system critical	..	..	..	100	..	..	..	..	..	..	..	40	50	
22. Coupling critical	..	..	..	100	Also make sure tooth fit is <i>tight!</i>							20	40	
23. Overhang critical	..	..	..	100	..	..	..	..	..	..	..	40	50	
Structural resonance of:	24. Casing	..	10	..	70	10	..	10	..	..	..	40	50	
	25. Supports	..	10	..	70	10	..	10	..	..	..	40	50	
	26. Foundation	..	20	..	60	10	..	10	..	..	..	30	40	
27. Pressure pulsations	Most troublesome if combined with resonance									100	..	30	40	
28. Electrically excited vibration	..	..	..	..	..	↓	..	..	..	..	..	30	40	
29. Vibration transmission	..	..	..	..	..		..	..	..	90	..	30	40	
30. Valve vibration	..	..	..	..	..		..	..	..	..	100	30	40	
Problem	The section below is meant to identify basic mechanisms													
31. Subharmonic resonance	..	Rare—Look for aerodynamic origin (seals)				100					..	..	30	30
32. Harmonic resonance	..	..	..	..	..	100	..	..	..	..	..	40	40	
33. Friction induced whirl	80	10	10	..	..	..	..	..	..	..	..	40	50	
34. Critical speed	..	..	..	100	..	..	..	..	..	..	..	40	50	
35. Resonant vibration	..	..	..	100	..	..	..	..	..	..	..	40	40	
36. Oil whirl	..	100	Watch for aerodynamic rotor-lift (partial admission, etc.)									40	50	
37. Resonant whirl	..	100	..	..	..	..	..	..	..	..	..	40	50	
38. Dry whirl	..	..	..	..	..	..	..	..	..	..	100	30	40	
39. Clearance induced vibrations	10	80	10	..	..	..	..	..	..	..	..	40	50	
40. Torsional resonance	..	..	..	40	20	20	..	..	..	20	..	Torsional		
41. Transient torsional	..	..	..	50	..	..	..	..	..	50	..	..	↓	

TABLE 2 Continued.

Direction and location of predominant amplitude							Amplitude response to speed variation during vibration-test runs											Cause	
Axial	Shaft	Bearings	Casing	Foundation	Piping	Coupling	Coming up					Slowing down							
							Stays same	Increases	Decreases	Peaks	Comes suddenly	Drops out suddenly	Stays same	Increases	Decreases	Comes suddenly	Drops out suddenly		
10	70	30	..	..	..	..	..	20	..	..	80	..	..	..	..	20	..	..	21
40	10	10	..	..	..	80	..	20	..	..	80	..	If loose	..	..	20	50 If loose	..	22
10	70	10	..	..	..	20	..	30	..	..	70	..	..	..	..	30	..	..	23
10	..	40	40	10	10	..	..	20	..	..	80	..	..	..	..	20	..	..	24
10	..	20	50	20	10	..	..	20	..	..	80	..	..	..	..	20	..	..	25
30	..	10	40	40	10	..	..	20	..	..	80	..	..	..	..	20	..	..	26
30	Can excite whirls or resonance	..	30	30	40	..	90	..	..	10%—Depending on origin of disturbance	..	..	..	90	10	..	..	..	27
30	↓	↓	40	40	20	..	90	..	..	↓	..	..	90	↓	..	..	..	..	28
30	↓	↓	40	40	20	..	90	..	..	↓	..	..	90	↓	..	..	..	..	29
30	..	..	80	10	10	..	80	..	..	..	..	10	10	80	↓	..	10	10	30
40	20 If bearing is excited	80	20	20	20	..	..	20	..	..	20	30	30	..	..	20	30	30	31
20	20	10	10	30	30	..	20	20	..	..	60	..	..	20	..	20	..	..	32
10	80	20	..	..	..	..	..	..	..	..	..	90	10	..	..	..	10	90	33
10	60	40	..	..	..	..	..	20	..	..	80	..	..	..	..	20	..	..	34
20	20	10	20	30	20	..	..	20	..	..	80	..	..	..	..	20	..	..	35
10	80	20	..	..	..	..	..	..	..	..	..	100	..	..	..	..	..	100	36
10	20	20	20	20	20	..	..	..	..	..	..	80	20	..	..	..	20	80	37
30	40	20	20	10	..	10	..	..	..	..	..	80	20	80	..	..	..	20	38
10	70	10	10	..	..	10	..	..	..	..	..	80	20	20	..	..	20	60	39
..	100	Lateral amplitude 40 40	..	..	10	..	20	..	..	..	30	30	20	20	..	..	20	30	40
..	Torsion 100	40	40	..	..	10	..	..	..	..	50	30	20	..	..	..	30	20	41

**TABLE 3** Bearing cap data-velocity unfiltered

Smooth	Acceptable	Marginal	Planned shutdown for repairs	Immediate shutdown
0.1 in/s (p) and less	0.1–0.2 in/s (p)	0.2–0.3 in/s (p)	0.3–0.5 in/s (p)	0.5 in/s (p)

Note: For gearing, add 0.1 in/s to all values.

p = peak

mm/s =  $25.4 \times$  in/s

2. Bent rotors can sometimes be straightened by the “hot-spot” procedure, but this should be regarded as a temporary solution because bow will come back in time. Several rotor failures have resulted from this practice. If blades or disks have failed, check for corrosion fatigue, stress corrosion, resonance, off-design operation.
3. Straighten bow slowly, running on turning gear or at low speed. If rubbing occurs, trip unit immediately and keep the rotor turning 90° using a shaft wrench every 5 minutes until the rub clears; resume slow run. This may take 12 to 24 h.
4. Often requires complete rework or new case, but sometimes a mild distortion corrects itself with time (requires periodic internal and external realignment). Usually caused by excessive piping forces or thermal shock.
5. Usually caused by poor mat under the foundation or thermal stress (hot spots) or unequal shrinkage. May require extensive and costly repairs.
6. Slight rub may clear, but trip the unit immediately if a high-speed rub gets worse. Turn by hand until clear.
7. Unless thrust bearing has failed, this is caused by rapid changes of load and temperature. Machine should be opened and inspected.
8. Usually caused by excessive pipe strain or inadequate mounting and foundation, but is sometimes caused by local heat from pipes or the sun’s heating the base and foundation.
9. Most trouble is caused by poor pipe supports (should use spring hangers), improperly used expansion joints, and poor pipe line up at casing connections. Foundation setting can also cause severe strain.
10. Bearings may become distorted from heat. Make a hot check, if possible, observing contact.
11. Watch for brown discoloration, which often precedes recurring failures. This indicates very high local oil film temperatures. Check rotor for vibration. Check bearing design and hot clearances. Check condition of oil, especially viscosity.
12. Check clearances and roundness of journal, as well as contact and tight bearing fit in the case. Watch out for vibration transmission from other sources and check the frequency. May require antiwhirl bearings or tilting-shoe bearings. Check especially for resonances at whirl frequency (or multiples) in foundation and piping.
13. This can excite resonances and criticals and combinations thereof at two times running frequency. Usually difficult to field balance because, when horizontal vibration improves, vertical vibration gets worse and vice versa. It may be necessary to increase horizontal bearing support stiffness (or mass) if the problem is severe.
14. Usually the result of slugging the machine with fluid, solids built up on rotor, or off-design operation (especially surging).
15. The frequency at rotor support critical is characteristic. Disks and sleeves may have lost their interference fit by rapid temperature changes. Parts usually are not loose at standstill.

16. It is often confused with oil whirl because the characteristics are essentially the same. Before suspecting any whirl, make sure everything in the bearing assembly is absolutely tight with an interference fit.
17. This should always be checked.
18. It usually involves shading pedestals and casing feet. Check for friction, proper clearance, and piping strains.
19. To obtain frequencies, tape a microphone to the gear case and record noise on magnetic tape.
20. Loose coupling sleeves are notorious troublemakers, especially in conjunction with long, heavy spacers. Check tooth fit by placing indicators on top, then lifting by hand or a jack and noting looseness (should not be more than 1–2 mils [0.025 to 0.05 mm] at standstill, at most). Use hollow coupling spacers. Make sure coupling hubs have at least 1 mil/in (1 mm/m) interference fit on shaft. Loose hubs have caused many shaft failures and serious vibration problems.
21. Try field balancing; more viscous oil (colder); larger, longer bearings with minimum clearance and tight fit; stiffen bearing supports and other structures between bearing and ground. This is basically a design problem. It may require additional stabilizing bearings or a solid coupling. It is difficult to correct in the field. With high-speed machines, adding mass at the bearing case helps considerably.
22. These are criticals of the spacer-teeth-overhang subsystem. Often encountered with long spacers. Make sure of tight-fitting teeth with a slight interference at standstill and make the spacer as light and stiff as possible (tubular). Consider using a solid or membrane coupling if the problem is severe. Check coupling balance.
23. Overhang criticals can be exceedingly troublesome. Long overhangs shift the nodal point of the rotor deflection line (free-free mode) toward the bearing, robbing the bearing of its damping capability. This can make critical speeds so rough it is impossible to pass through these speeds. Shorten the overhang or put in an outboard bearing for stabilization.
24. Casing resonance is also called case drumming. It can be very persistent but is sometimes harmless. The danger is that parts may come loose and fall into the machine. Also, rotor/casing interaction may be involved. Diaphragm drumming is serious because it can cause catastrophic failure of the diaphragm.
25. Local drumming is usually harmless, but major resonances, resulting in vibration of the entire case as a unit, are potentially dangerous because of possible rubs and component failures, as well as possible excitation of other vibrations.
26. Similar problems exist as in 24 and 25 with the added complications of settling, cracking, warping, and misalignment. This cause may also produce piping troubles and possible case warpage. Foundation resonance is serious and greatly reduces unit reliability.
27. Pressure pulsations can excite other vibrations with possible serious consequences. Eliminate such vibrations using restraints, flexible pipe supports, sway braces, shock absorbers, and so on, plus isolation of the foundation from piping, building, basement, and operating floor.
28. It occurs mostly at two times line frequency (7200 cpm), coming from motor and generator fields. Turn the fields off to verify the source. It is usually harmless, but if the foundation or other components (rotor critical or torsional) are resonant, the vibrations may be severe. There is a risk of catastrophic failure if there is a short circuit or other upsets.
29. This can excite serious vibrations or cause bearing failures. Isolate the piping and foundation and use shock absorbers and sway braces.
30. Valve vibration is rare but sometimes very violent. Such vibrations are aerodynamically excited. Change the valve shape to reduce turbulence and increase rigidity in the valve gear. Make sure the valve cannot spin.
31. The vibration is exactly one-half, one-quarter, one-eighth of the exciting frequency. It can be excited only in nonlinear systems; therefore, look for such things as looseness

and aerodynamic or hydrodynamic excitations. It may involve rotor “shuttling.” If so, check the seal system, thrust clearances, couplings, and rotor-stator clearance effects.

32. The vibrations are at two, three, and four times exciting frequency. The treatment is the same as for direct resonance: change the frequency and add damping.
33. If the cause is intermittent, look into temperature variations. Usually the rotor must be rebuilt, but first try to increase stator damping, add larger bearings (tilting-shoe), increase stator mass and stiffness, and improve the foundation. This problem is usually caused by maloperation, such as quick temperature changes and fluid slugging. Use membrane-type coupling.
34. This is basically a design problem, but is often aggravated by poor balancing and a poor foundation. Try to field-balance the rotor at operating speed, lower oil temperature, and use larger and tighter bearings.
35. Add mass or change stiffness to shift the resonant frequency. Add damping. Reduce excitation and improve system isolation. Reducing mass or stiffness can leave the amplitude the same even if resonant frequency shifts because of stronger amplification. Check “mobility.”
36. Stiffen the foundation or bearing structure. Add mass at the bearing, increase critical speed, or use tilting-shoe bearings (which is the best solution). First, check for loose fit of bearings in bearing case.
37. Same comments as 36 with additional resonance of rotor, stator, foundation, piping, or external excitation; find the resonant members and the sources of excitation. Tilting-shoe bearings are the best. Check for loose bearings.
38. Sometimes you can hear the squeal of a bearing or seal, but frequency is usually ultrasonic—very destructive. Check for rotor vanes hitting the stator, especially if clearances are smaller than the oil film thickness plus rotor deflection while passing through the critical speed.
39. Usually accompanied by rocking motions and beating within clearances. It is serious especially in the bearing assembly. Frequencies are often below running frequency. Make sure everything is absolutely tight, with some interference. Line-in-line fits are usually not sufficient to positively prevent this type of problem.
40. This problem is very destructive and difficult to find. The symptoms are gear noise, wear on the hack side of teeth, strong electrical noise or vibration, loose coupling bolts, and fretting corrosion under the coupling bolts. There is wear on both sides of coupling teeth and possibly torsional-fatigue cracks in keyway ends. The best solution is to install properly tuned torsional vibration dampers.
41. It is similar to 40, but encountered only during startup and shutdown because of very strong torsional pulsations. It occurs in reciprocating machinery and synchronous motors. Check for torsional cracks.

**Impeller Unbalance** Impeller unbalance appears as a  $1\times$  running speed frequency vibration approximately 90% of the time and may be mechanical or hydraulic in origin. Impeller mechanical unbalance is a frequent cause of mechanical seal and bearing failures. Many mechanics will never think of checking impeller balance until heavily pitted areas appear. Because of the nonhomogeneous nature of most castings, corrosion is usually more aggressive in one area of the impeller. The degree of etching or surface pitting is a judgmental indicator of balance change. Impeller balancing should be part of the shop repair procedure for impellers over 10 in (25 cm) at 3600 rpm. It is good practice, when balancing an impeller, to keep the impeller bore to balance mandrel fit no greater than 0.001 in (0.0254 mm) loose. Installing the impeller with the keyway up on the balance mandrel and pump shaft will help eliminate some of the unbalance due to shaft centerline shift.

**EXAMPLE** A 38-lb (17.2 kg),  $15\frac{1}{2}$ -in (39.4-cm) diameter impeller operating at 3600 rpm is balanced on a machine good to  $25 \times 10^{-6}$  in ( $635 \times 10^{-6}$  mm) using an expanding man-

drel. The impeller is then installed on its shaft, which has a loose fit of 0.0035 in (0.0889 mm). The forces created by this shift in the center of mass is calculated as follows:

in USCS units

$$\begin{aligned}\text{Unbalance} &= \text{eccentricity of impeller (in)} \times \text{impeller wt. force (oz)} \\ &= \frac{0.0035}{2} \times 38 \times 16 = 1.064 \text{ oz} \cdot \text{in} \\ \text{Unbalance force} &= 1.77 \left( \frac{\text{rpm}}{1000} \right)^2 \times \text{unbalance (oz} \cdot \text{in)} \\ &= 1.77 \left( \frac{3600}{1000} \right)^2 \times 1.064 = 24.4 \text{ lb}\end{aligned}$$

in SI units

$$\begin{aligned}\text{Unbalance} &= \text{eccentricity of impeller (mm)} \times \text{impeller wt, mass (g)} \\ &= \frac{0.0889}{2} \times 17.2 \times 1000 = 765 \text{ g} \cdot \text{mm} \\ \text{Unbalance force} &= 0.01094 \left( \frac{\text{rpm}}{1000} \right)^2 \times \text{unbalance (g} \cdot \text{mm)} \\ &= 0.01094 \left( \frac{3600}{1000} \right)^2 \times 765 = 108.5 \text{ N}\end{aligned}$$

The example also points out that the unbalance force generated by loose fit impellers with keyways mounted in one plane could be quite high. This force could be minimized by staggering keyways or randomly orienting the impellers on the balance mandrel. Shifting of shrink-fitted, well-balanced impellers on multistage and high-speed double-suction pumps after a period of operation can result in unbalance. The shifting of the impeller is due to the relaxation of residual stresses that built up as the impeller cooled and contracted around the shaft. Shaft vibration and flexing tend to relieve the residual stress and cause the impeller to cock or bow the shaft from the original balance centerline.

Standards should be referred to for balancing pumps and their drivers. When balancing, consideration must be given to the need for balancing at rated speed in order to properly evaluate the importance of shaft deflection due to modal components of unbalance. See References 12 and 13.

**Hydraulic Unbalance** Uneven flow distribution entering the impeller can cause a  $1 \times$  running speed frequency type of vibration. The unbalance occurs because the flow is not equal in all vane passages. An example of this is a double-suction impeller with a short, straight run to the pump and an elbow in the horizontal plane. Flow from the elbow does not have time to straighten and therefore enters both sides of the impeller unequally. A similar condition results if suction is taken from a tee off the main header. Unequal and unsteady flow into the impeller may cause axial thrust and high axial vibrations. Thus, it is good design practice to install elbows vertically in double-suction pumps.

In double-suction pumps, the nonsymmetrical positioning of the impeller or the offset of the upper case half of the lower case half will cause a  $1 \times$  unbalance due to nonsymmetrical flow.

Recirculation forces and pulsation recirculation within a pump (which can occur when flow is less than design) may manifest themselves in the form of a noise and/or vibration with random frequencies, along with pressure pulsation that may be seen on a pressure gage. Recirculation may also appear in the piping system as vibration and noise. Increased *NPSHA* has helped in a few cases, especially if the recirculation is mainly on the suction side of the impeller. After a pump has a recirculation problem in a given system and the

flow cannot be increased using a bypass, little can be done to the pump itself unless the system characteristics allow an impeller change.

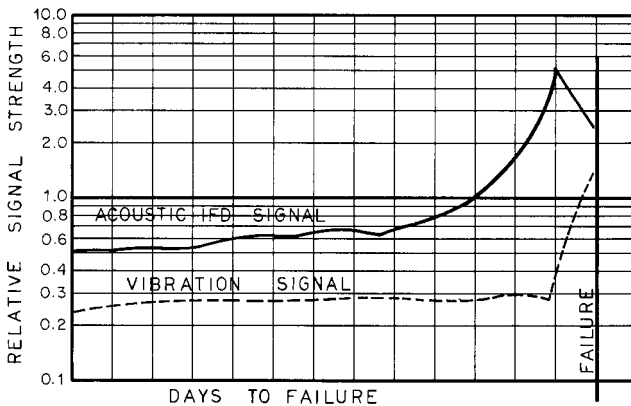
**Antifriction Bearings** Vibrations generated by ball bearings cover a wide range of high frequencies that are not necessarily a multiple of the shaft running speed. The frequency readings obtained during analysis are somewhat unsteady because of the resolution of the filters in a hand-tuned analyzer. The amplitude reading may also be somewhat unsteady.

Experience has shown that hand-tuned field analyzers tend to show the last stage of the bearing failure. Monitoring of stress waves or shock pulses (impact energy) on the pump bearing housing will show failure trends that will generally precede an increase in the detectable level of mechanical vibration. This method of failure detection is called acoustic high-frequency monitoring or incipient-failure detection (IFD). A comparison between conventional methods and the acoustic high-frequency method is shown in Figure 23.

Accurate analysis of pump bearings and other machinery can also be made using a velocity sensor good to 1500 Hz or an accelerometer. Data should be recorded and processed through a real-time analyzer with at least 256-line resolution capability and a band selectable analysis option. Analysis of antifriction bearings using a real-time analyzer and equations for calculating frequencies generated by defective bearings can be found in Reference 7.

Accurate and extended analysis of pump bearing vibration is generally not needed. A majority of bearing problems are currently identified by an acoustic noise during operation. What is needed by maintenance personnel is a quick and reliable method to monitor bearings and determine when a bearing is failing and the rate of bearing deterioration. At present, there are some expensive instruments that can be purchased, but none of them meet maintenance requirements.

Currently, the best method for reducing bearings analysis is prevention of the failure. Most antifriction pump bearings fail for one of several reasons: (1) water gets into the oil, (2) automatic oiler is not adjusted properly (this cause is most often overlooked and will continue to produce a short life to failure cycle), (3) product gets into the oil, (4) acidic vapors condense and break down the oil, (5) mounting techniques or fits are improper, (6) new bearing is defective. The solution to high-humidity problems and problems with acidic units is the use of an oil mist lubrication system. If this cannot be economically installed, an aggressive preventative maintenance program on a monthly to every-other-month basis is required.



**FIGURE 23** Relative signal strength versus days to failure for acoustic IFD and conventional vibration monitoring methods

**Baseplates** With the change from low rotating speeds and cast iron baseplates to the less rigid fabricated steel baseplates and higher rotating speeds, higher operating temperatures, and larger impellers have greatly increased the probability of baseplate vibrations, distortion, and a decreased stiffness for rotor dynamics. Reference 6 has increased coverage for piping loads and the option of a heavy-duty baseplate over the proposed standard baseplate. The reference specifies a standard baseplate and pedestal support that are twice as rigid as specified in the fifth edition of the reference standards.

Baseplate vibration problems can be resolved at the design stage or during construction. Engineering specifications should call for leveling screws, grout filling holes [4 in (10 cm) minimum, 6 in (15 cm) preferred for each bulkhead section], venting holes [ $4\frac{1}{2}$  in (11 cm) holes to each bulkhead section], and corrosion protection. A check of the outline dimension approval drawing should also be made for proper grout hole placement (bulkhead and cross bracing must be shown on the drawing). Construction specifications should call for proper baseplate preparation before grouting.<sup>8</sup> API pumps should have epoxy grout bonding the baseplate to the concrete foundation.

After proper cure, the baseplate should be tapped for voids, especially between and under the pump centerline supports.

**EXAMPLE** A high vertical vibration occurred on the coupling end bearing at vane passing frequency on a multistage volute pump. The vertical vibration was 2.5 times the horizontal; thus, a check of the bearing pedestal and baseplate was in order. The hammer test on the pan of the baseplate under the bearing pedestal showed complete lack of grout. Vertical vibration on the pan was 1.8 times the horizontal. Regrouting eliminated the pan vibration and reduced the vertical vibration to one-half of the horizontal. Lack of proper stiffness from the baseplate can and will lower some pump critical speeds into the operating range.

When a complete analysis is being done on a problem pump, take several pedestal readings (top, middle, and bottom on the side and end) and several readings on the pan of the baseplate. The middle, bottom, and pan readings should show good attenuation.

## REFERENCES

---

1. IRD Mechanalysis. "Methods of Vibration Analysis." Technical paper no. 104-1975, IRD, Cleveland.
2. Garguilo, E. P. Jr. "A Simple Way To Estimate Bearing Stiffness." *Machine Design*, July 24, 1980, p. 107.
3. Dodd, V. R. *Total Alignment*. Petroleum Publishing, Tulsa, 1975.
4. "Alignment Tutorium." *Proc. Tax. A&M Turbomachinery Sym.*, December 1980.
5. Sobre, J. S. "Operating Problems with High Speed Turbomachinery: Causes and Corrections," ASME Petroleum Mechanical Engineering Conference, Dallas, Sep. 1968.
6. American Petroleum Institute. *Centrifugal Pumps for General Refinery Services. API Standard 610, 6th ed.* Washington, D.C., 1981.
7. Taylor, J. I. "An Update of Determination of Anti-Friction Bearing Condition by Spectral Analysis." *Vibration Institute, Machinery Vibrations Monitoring Analysis Seminar*. New Orleans, April 1981.
8. Murray, M. G. Jr. "Better Pump Grouting." *Hydrocarbon Processing*. February 1974.
9. Jackson, C. *A Practical Vibration Primer*. Gulf Publishing, Houston, 1979.
10. Mitchell, J. S. *An Introduction to Machinery Analysis and Monitoring*. 1st ed., Penn-Well Books, Tulsa, 1981.
11. Messina, J. P., and S. P. D'Alessio. "Align Pump Drives Faster by Well-Planned Procedure." *Power*, March 1983, p. 107.



12. American National Standard. *Procedures for Balancing Flexible Rotors*, ANSI S2.42, New York, 1982.
13. American National Standard. *Balance Quality of Rotating Rigid Bodies*, ANSI S2.19, New York, 1975.

### **FURTHER READING**

---

- Bloch, H. P. "Improve Safety and Reliability of Pumps and Drivers." *Hydrocarbon Processing*, May 1977, p. 213.
- Bussemaker, E. J. "Design Aspects of Baseplates for Oil and Petrochemical Industry Pumps." IMechE Paper C45/81, Netherlands, 1981, p. 135 (English ed.).
- Jackson, C. "Alignment of Pumps." Centrifugal Pump Engineering Seminar, ASME South Texas Section Professional Development, Sec. 9, Houston, 1979.
- Jackson, C. "Alignment of Rotating Equipment." NPRA, MC-74-7, Houston, 1974.
- Sprinker, E. K., and F. M. Patterson. "Experimental Investigation of Critical Submergence for Vortexing in a Vertical Cylindrical Tank." ASME Paper 69-FE-49, June 1969.
- Von Nimitz, W. W. "Dynamic Design Criteria for Reciprocating Compressor and Pump Installations." Presented at the 27th Annual Petroleum Mechanical Engineering Conference, New Orleans, September 19, 1972.
- Wachel, J. C., and C. L. Bates. "Escape Piping Vibrations While Designing." *Hydrocarbon Processing*, October 1976, p. 152.

# 2.3.4 CENTRIFUGAL PUMP MINIMUM FLOW CONTROL SYSTEMS

HORACE J. MAXWELL  
DAVID A. KALIX

In designing centrifugal pumps, engineers strive to develop specific internal geometry that will produce head and flow with low energy loss. Each pump is designed for a specific head versus flowrate for the given impeller speed. The head and flowrate on this family of “characteristic” curves where the energy loss is minimum is known as the Best Efficiency Point (BEP).

In application, pumps spend a significant portion, if not all of their life, operating at conditions other than BEP. This is normal and is due to a combination of system design conditions (for example, static head, piping and valve impedances, and so on), available pump designs (that is, capacities and heads) and actual plant operating requirements. Low flow related problems occur when pumps continuously operate in or repetitively cycle into flow regions that are significantly below the BEP (for example, 50% of BEP). In these low-flow regions, pump and system component performance and longevity can be adversely affected.

Low flow problems are known to be worst for large high-energy pumps (for example, boiler feedwater), for pumps handling hot liquids, for pumps that handle liquids that have solid particles, and for pumps for low net positive suction head (*NPSH*) service. A well-designed minimum flow control system can establish an environment that will substantially improve pump and system performance. The following chapter will briefly review the topics that should be considered when designing a minimum flow system for a centrifugal pump.

## **FACTORS AFFECTING LOW FLOW RATE PUMP OPERATION** \_\_\_\_\_

Collectively, the following broadly classed factors have been recognized as the major contributors to low flow pump problems.

**Thermal Factors** The increase in temperature of the liquid within the pump is directly related to the pump's efficiency. The energy that is available to heat the flowing liquid and the pump casing is basically the difference between the power input to the pump (brake horsepower) and the useful work done by the pump (liquid horsepower). At low flow conditions, centrifugal pumps are very inefficient and a significant amount of input energy is lost and heats the liquid and the pump assembly. Refer to Subsection 2.3.1 and Chapter 12 for more discussion on thermal effects.

**Hydraulic Instabilities** When the pump is operating significantly below the BEP, flow streamlines (that is, patterns) within the pump change considerably from the rated design streamlines. Fluid eddies are most likely to develop at the inlet and discharge of the impeller resulting in flashing, cavitation, and shock waves that often produce vibration and serious component erosion. This phenomenon is classically known as internal recirculation. It can occur at the pump inlet (suction) and discharge. Refer to Subsection 2.3.1 and 2.3.2 for a more in-depth discussion on this topic.

**Mechanical Loads** As the flowrate through the pump decreases, steady state loads increase and superimposed dynamic cyclic loads appear radially and axially on the impeller and shaft. The dynamic cyclic component increases significantly when recirculation within the pump occurs. Bearing damage, shaft and impeller breakage, and rubbing wear on casing, impeller and wear rings can occur. See Subsections 2.3.2 and 2.3.3 for discussion of this subject.

Axial-flow and mixed-flow pumps with high specific speed produce comparatively higher head and take comparatively more power at low flow. A bypass system may be necessary not only to reduce component loading and stress but also to prevent motor overload. See Subsection 2.3.1 and Section 8.1 for discussion.

**Abrasive Fluids** Liquids containing a large amount of abrasive particles, such as sand or ash, must flow continuously through the pump. If flow decreases, the particles can circulate inside the pump passages and quickly erode the impeller casing, wear rings, and shaft.

## ESTABLISHING MINIMUM PUMP FLOW REQUIREMENTS

---

The bypass system designer must know the minimum pump flow specified by the pump manufacturer in order to properly design a bypass system. The four previously discussed topics should be evaluated in detail by the pump manufacturer to establish the minimum flowrate specification. Minimum flowrate specifications are generally established through a combination of analytical and experimental techniques coupled with field performance data.

**Thermal Considerations** The maximum allowable temperature rise of the pump is primarily based on two points: the permissible pump casing and shaft thermal growth and the flash point temperature of the pumpage. Pump manufacturers use analytical, laboratory and field data to validate their thermal analysis to ensure that pumps do not seize within the allowable temperature operating ranges. Refer to Subsection 2.3.1 for temperature rise calculations.

Applications involving extremely high or low temperature fluids may require more in-depth analysis to determine if individual component thermal growth is the limiting factor in determining minimum flowrate. Additionally, certain chemicals, which polymerize or solidify at particular temperatures, may establish the minimum flowrate specification. Chapter 12 and Subsection 2.3.1 provide more detail on this subject.

**Hydraulic Considerations** The minimum bypass flow requirement for most pumps is based on minimum continuous stable flowrate, a hydraulic criterion, rather than a temperature rise. Pump internal recirculation will occur at both the impeller inlet and

impeller outlet as flowrates are reduced. Internal recirculation will occur at flowrates well above those that cause temperature concerns. Refer to Subsection 2.3.1 for a detailed evaluation of this topic.

**Mechanical Considerations** It is necessary to know how head, radial thrust, axial thrust and power vary with capacity before deciding on minimum allowable flow. Bearing capacity, motor rating, and stresses in drive and driven components are important influences.

**Abrasive Wear Considerations** Relatively high bypass flowrates may be required to protect the pump against abrasives in the liquid. Heavy wear can occur at flows below 85% of the best efficiency point. The designer must establish the minimum pump flow specification using the pump manufacturer's recommendation and his experience with comparable pumps and liquid/solid mixtures.

### MINIMUM FLOW CONTROL SYSTEM DESIGN FACTORS

---

**Pump Size** Capacity, power, specific speed, and suction specific speed are all factors that must be examined when designing a bypass system. These factors have a direct impact on the cost of building and operating the bypass system. Use of a continuous bypass system will require an even larger pump and driver to supply both the process and bypass flow requirements simultaneously.

**Discharge Pressure** High discharge pressures result in high head loss in bypass valves, components, and lines. Liquids that can flash and cavitate demand special precautions to minimize damage in valving, orifices, and piping.

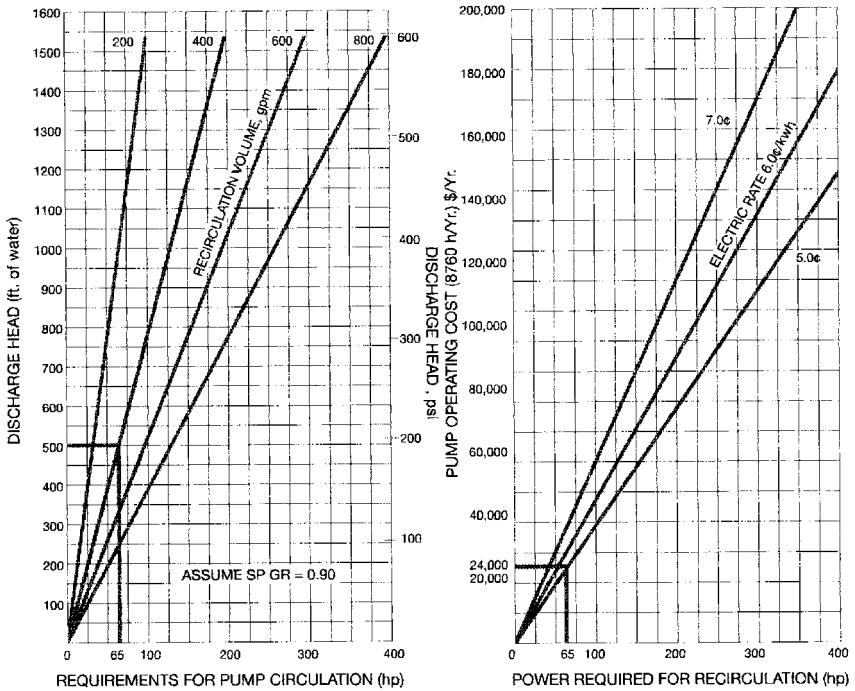
**Available Heat Sink** Bypass flow must be reintroduced into the system far enough upstream to prevent progressive temperature buildup or flow disturbance in the pump suction. This may mean a simple discharge back to an uninsulated inlet line or discharge to a receiving tank or cooler with enough area and enough inflow of cool liquid to handle the thermal load. Bypass flow can discharge into a deaerator storage tank, a condenser, a flash tank, or a cooling pond. Elevation, distance, and pressure inside the receiving tank are also factors, as is the fact that the interior must be available for inspection and for repair of spargers, spray or distribution pipes, orifices, and backpressure regulators.

**Pump Design** A pump's design and materials of construction often affect the minimum allowable percentage of flow. With thermal effects, pumps vary in the length of time that they will tolerate shut off or low flow. This is important in designing the bypass system valves, instrumentation, and controls.

Hydraulic effects at low flow are most apparent in high-energy pumps. The pump manufacturer should state the continuous minimum hydraulically acceptable flow for a given pump—and how it was determined. With axial-flow pumps, the shape of the pump head curve may be a factor in selecting the required bypass flow percentage. If feasible, a witness shop test of the pump should be specified to demonstrate and verify minimum flow recommendations.

**Liquid Pumped** Liquids that flash and cavitate generally required a high bypass flow percentage. Examples are liquids near the boiling point or at high pressure. Abrasives in the liquid may require more bypass than would be needed for thermal reasons alone.

**Energy Costs** A high energy cost to operate the pump requires careful consideration of bypass system design. The evaluation should compare equipment installation costs, maintenance, and energy costs for various bypass configurations. Figure 1 shows the annual pumping costs for a continuous bypass type system based on bypass flow, pressure and energy rates. The example shows a pump with a discharge head of 500 ft (152



**FIGURE 1** Annual pumping cost estimate for continuous bypass systems (metric conversions: ft  $\times$  0.3048 = m, gpm  $\times$  0.277 = m<sup>3</sup>/h, hp  $\times$  0.746 = W)

m) and a bypass flow requirement of 400 gpm (91 m<sup>3</sup>/h). Based on an energy cost of 5.0 cents/KWH, the annual cost for continuous bypass is \$24,000. An automatic bypass system will only open the bypass when process flow demand is low. The total design life energy costs of a continuous bypass system can easily exceed the hardware costs of an automatic bypass system.

**Noise Considerations** Bypass systems can easily exceed OSHA requirements for occupied spaces if not designed properly. High pressure drops and high fluid velocity increase noise. Multi-stage pressure reduction, heavy wall pipe, insulation, and silencers will all combine to reduce noise to acceptable levels. See Section 8.4 for a further discussion of this topic.

**Process System Design and Operational Expectations** Bypass system design will depend on the plant design life and the expected process operational requirements. For example, a swing-loaded electric power plant will have far different pump operating requirements than a low-pressure emergency fire water system. The bypass system designer must evaluate installation, maintenance, and operating costs for the life of the process system with the expected utilization. If the actual operating conditions differ significantly from the design, the configuration of the bypass system should be reevaluated. For example, a process designed for normal operation with one pump at 75% of maximum capacity may put severe demands on the bypass system if the pump is operated continuously at 20% of maximum capacity.

## LOW FLOW PROTECTION SYSTEMS

### Bypass Systems—Types/Design Considerations

**CONTINUOUS BYPASS SYSTEMS** As the title implies, continuous bypass systems provide continuous flow whenever the pump is running, regardless of the process demand. Figure 2 illustrates a simple system, with a bypass line branching off the pump discharge upstream of the main line check valve and containing a fixed orifice dimensioned by analysis to provide minimum required pump flow. The bypass line discharges into a reservoir that is at a lower pressure than the pump discharge. The bypass line can also discharge directly into the pump supply line. However, the piping system design must ensure that the bypass liquid temperature does not increase to an unacceptable level. Additionally, vapor bubbles formed in the bypass by the pressure reduction process may be introduced into the pump. This will affect pump performance and longevity. Locating the bypass branch-off before the discharge check valve as shown keeps backflow from the process or from a parallel operating pump from going back to the receiving tank or back through the pump during a pump shutdown. Consideration should also be given to installing a check valve in the bypass line.

The size of the bypass pipe depends on flow and piping configuration. If the pressure drop through the orifice results in flashing flow, the orifice should be located at the end of the bypass piping and should discharge directly into the larger receiving tank or larger downstream piping. The discharge flow should be directed so it does not impinge on the walls of the receiving tank but rather into the liquid to absorb the force of cavitation implosion. Valves and fittings located immediately downstream of the orifice may be damaged by cavitation. Full ported gate or ball valves are less susceptible to damage. Waterhammer and erosion are not problems in well-designed continuous bypass systems.

The pump and prime mover must be sized to simultaneously supply both the bypass flow and the maximum process flow at the required pump discharge pressure.

**AUTOMATIC BYPASS SYSTEMS** Automatic recirculation systems control the bypass flow in relation to the process flow. The sum of the process and bypass flowrates will always exceed the minimum flowrate specified to protect the pump. Two essential elements of these systems are a device to measure the process flow and a device to control the bypass flow. Compared with continuous bypass, these systems reduce energy consumption and pump horsepower requirements.

The bypass flow can be regulated by either “Modulated” or “On-Off” control. When bypass flow is “Modulated,” the bypass flow is inversely proportional to the process flow.

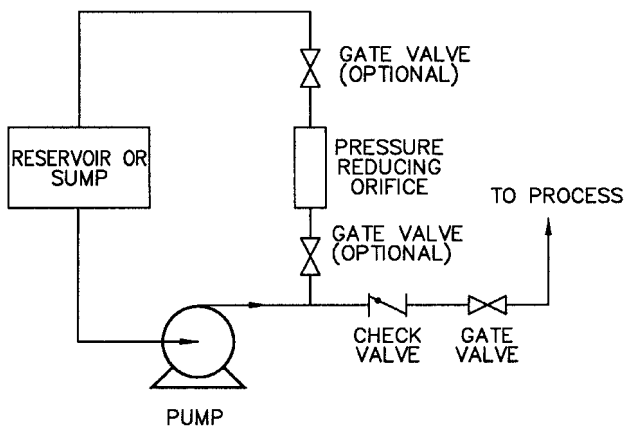


FIGURE 2 Typical continuous bypass system

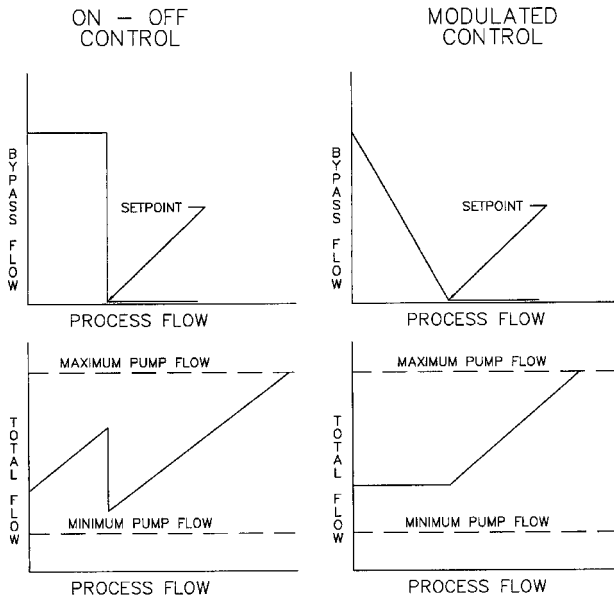


FIGURE 3 Comparison of On-Off versus Modulated automatic bypass flow control.

The bypass is shut when process flow is greater than the control setpoint (that is, minimum flowrate required), opens more as the process flow is reduced, and is full open when the process flow is zero. With “On-Off” bypass control, the bypass is open fully when process flow is below the setpoint and is shut when the process flow is above the setpoint.

Figure 3 illustrates these control methods and the effect on total pump flow. The total pump flow is the sum of the process and bypass flows; it is the flow that enters the pump suction. The “On-Off” control graph shows that there is a step change in the total flow when the bypass opens or closes. The “Modulated” control regulates the total flow smoothly when the process flow is below the setpoint. Either method will protect the pump from damage due to low flow. However, “On-Off” control may produce large pump discharge pressure variations depending on the shape of pump head curve. Rapid pump flow changes may produce damaging hydraulic or mechanical shocks. This will reduce pump life and increase maintenance. Modulated bypass control is required when the minimum flowrate specification exceeds approximately forty percent of the rated pump capacity. If “On-Off” bypass control is used above this point, the pump may exceed its capacity rating with resultant pressure pulsation and unsteady flow.

**CONTROL LOOP SYSTEMS** A typical automatic bypass system, based on an instrumented flow control loop, is shown in Figure 4. This system requires a flow meter, a check valve, a bypass control valve, a valve controller and a pressure-reducing orifice.

The flow meter can be placed at the pump inlet or discharge before the bypass tee (as opposed to it having to be placed after the bypass tee in an “On-Off” system). The controller compares the flow meter signal with the setpoint (minimum pump flow required) and operates the bypass control valve.

Single stage control valves are commonly used in low pressure systems with an orifice for pressure reduction located downstream. However, these are not suitable for high pressure differentials or for the controlling of cavitation or flashing. Pressure reducing valves with multi-stage trim, good seat tightness, and low pressure recovery characteristics are widely used in this service. Refer to Chapter 7 for a detailed discussion of control valve characteristics and selection.

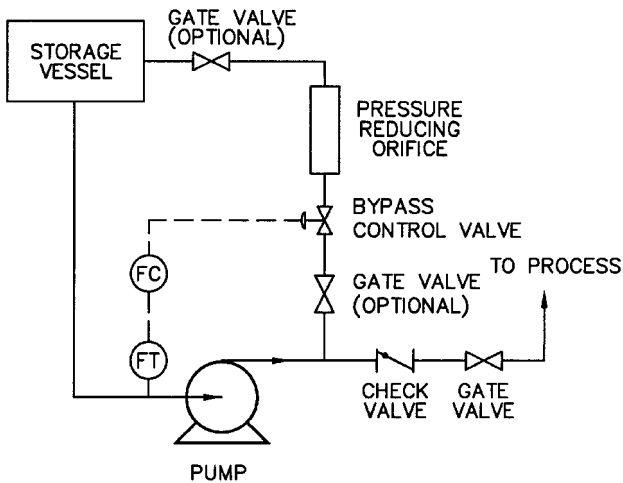


FIGURE 4 Typical automatic bypass system based on flow control

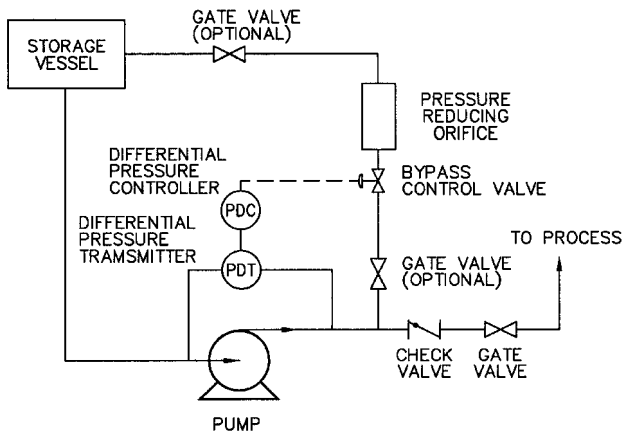


FIGURE 5 Typical automatic bypass system based on pump differential head

The bypass pressure reducing orifice handles the high velocity and erosive forces of the bypass flow. However, the handling of cavitation and flashing by this fixed restriction is limited. The orifice is sized to operate properly at one bypass flow condition. At low flows, the orifice does not provide the correct pressure reduction as designed.

The check valve is placed in the main line, as shown in Figure 4, to prevent reverse flow through the pump. The pump and motor bearings can be damaged if rotated in reverse. Pressure drop through the check valve must be considered in pump sizing in addition to other piping and valve pressure losses.

A typical automatic bypass system based on pump differential head is shown in Figure 5. This system is identical to the flow controlled bypass system except that pump differential head is measured instead of flow. This system can only be used with continuously rising pump head characteristic curves. The system will have to be adjusted for each individual pump characteristic and later adjusted if this characteristic changes over the life of the pump.



Depending on the bypass valve and control instrumentation selected, these systems can provide either “Modulating” or “On-Off” bypass control. Valves, instrumentation, and controls must be individually sized for the service conditions. All components must be integrated together to provide bypass flow control that meets the pump and process operational design criteria.

**The Automatic Recirculation Control (ARC®) Valve** This valve provides bypass flow control, pressure reduction, and reverse flow pump protection all within a single unit. This single valve combines the functions of the check valve, pressure reducing orifice, pipe tee, control instrumentation flow meter, and bypass control valve that are all required in the instrumented control loop bypass system. Valves can be designed to provide either “Modulated” or “On-Off” bypass control. The operation of all ARC valves is fundamentally the same. The flow sensing element (check valve disc) responds to the process flow demand and opens or closes the self-contained bypass control valve. Differences in ARC valve design center around bypass valve actuation method, repairability, serviceability, and adjustability. Figure 6 illustrates a typical ARC valve bypass system.

**Pilotless Trim Design** The simplest of ARC valve designs operate the bypass flow control valve directly by the flow sensing element. The construction of a typical ARC for low pressure service is shown in Figure 7. The basic operation of this valve is shown in Figure 8. At zero main flow (“A”), the bypass provides full recirculation flow. As main flow increases (“B”), the bypass modulates proportionally closed. At full main flow (“C”), the bypass is shut. The pressure reduction from the pump discharge to the bypass is accomplished by the characterized orifices in the bypass element that is attached to the disc. However, the differential pressure from inlet to bypass imposes static and dynamic forces on the disc assembly. These unbalanced forces interfere with the normal disc motion and limit the maximum differential pressure for pilotless trim. There is an upper differential pressure limit at which this design will not operate satisfactorily and pilot operated bypass control must be used.

**Pilot Operated Trim** Pilot operated bypass control valves utilize a combined hydraulic-mechanical force to control the bypass flow. Only a relatively small mechanical force is necessary to hydraulically generate the large forces required to operate a bypass flow control valve in a high-pressure system. Figure 9 illustrates a pilot-operated bypass that utilizes a lever connected to the check valve disc to actuate the pilot. Figure 10 illustrates a pilot operated multistage bypass operated by an in-line pilot valve. Pilot-operated valves require more components and seals than unbalanced valves and are therefore more costly.

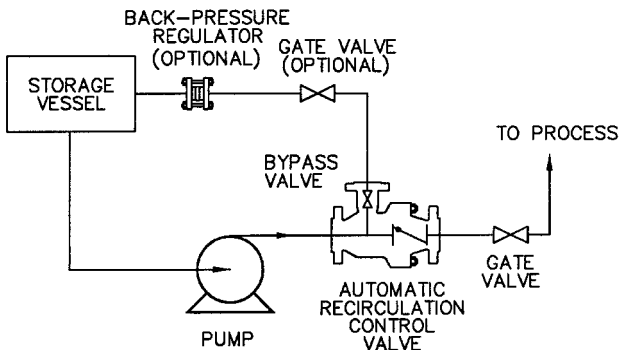


FIGURE 6 Typical ARC valve bypass system

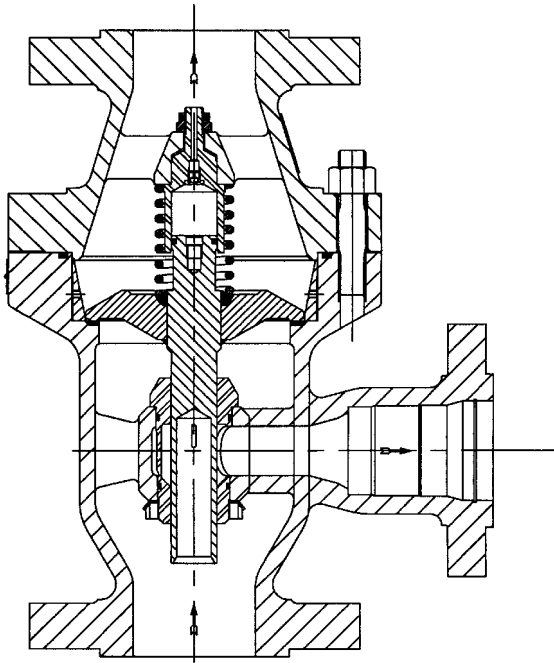


FIGURE 7 Construction of a typical ARC valve for low-pressure service

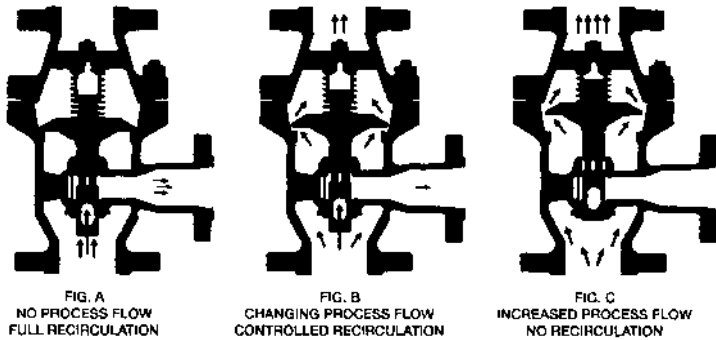


FIGURE 8A through C Basic ARC valve operation at three process flow conditions

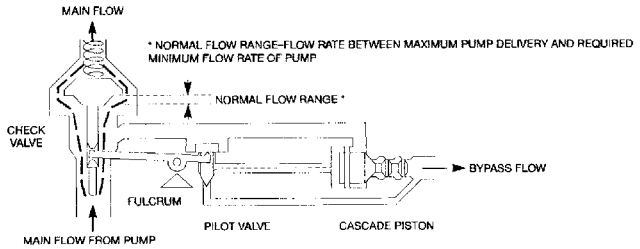
**Serviceability** ARC valves can be designed for in-line serviceability. Access is provided to the valve's internal components for inspection or repair without disturbing the process or bypass piping. Figure 11 illustrates a valve designed to be serviced in-line.

### SAFETY SHUTDOWN SYSTEMS

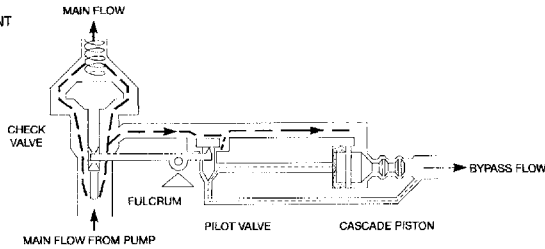
These controls are normally provided as backup pump protection for the continuous bypass and automatic bypass control systems. They should only operate if the normal system fails due to mechanical or operator causes. In each case, the protection system trips the pump off.

**NORMAL MAIN FLOW**

CHECK VALVE—OPEN  
 PILOT VALVE—CLOSED  
 CASCADE VALVE—CLOSED

**LOW MAIN FLOW**

CHECK VALVE—AT SWITCH POINT  
 PILOT VALVE—PARTIALLY OPEN  
 CASCADE VALVE—OPENING

**NO MAIN FLOW**

CHECK VALVE—CLOSED  
 PILOT VALVE—OPEN  
 CASCADE VALVE—OPEN

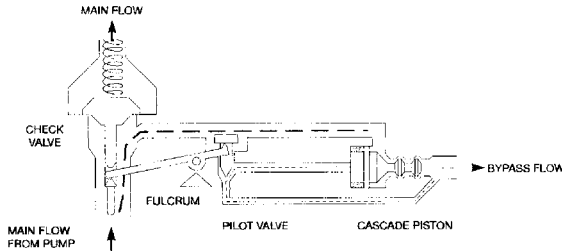


FIGURE 9 Operation of a typical pilot-operated ARC bypass valve actuated through a lever mechanism

**Head** This requires only an accurate pressure switch, set for a discharge pressure corresponding to the total pump head when the pump is close to the shutoff capacity. For conservative results, calculate based on minimum suction pressure. To use this method, the pump characteristic must rise continuously to shutoff. Control circuitry may require delays to reject spurious pressure surges.

**Temperature** A temperature sensor mounted on the pump casing or in the discharge and close to the pump can signal for a shutdown of all or some of the operating pumps. The trip can be on either a high temperature sensing or a high differential temperature sensing between inlet and discharge. This method can protect against large temperature rises (occurring at perhaps 5% or less of capacity) but is less sensitive to smaller rises at higher percentages of capacity where adverse hydraulic effects begin for large and high-power pumps.

**Low-Flow Systems** These protection systems can be configured in various ways. A low-flow switch can trip the pump off at a predetermined setpoint. A flow meter can signal a controller to shut down the pump. If this protection circuit is installed, the pump start circuit must temporarily bypass this trip in order to start the pump. This is normally accomplished by a spring-loaded switch that bypasses the low-flow trip when held in the "Start" position, but activates the trip protection in the "Run" position.

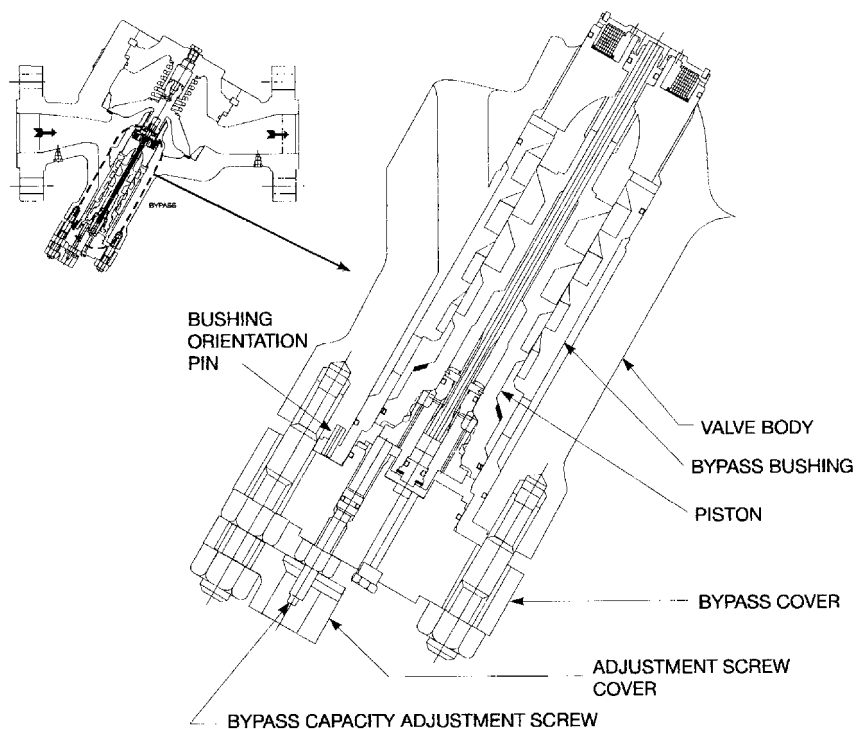


FIGURE 10 Pilot operated multistage bypass trim actuated by an in-line pilot valve

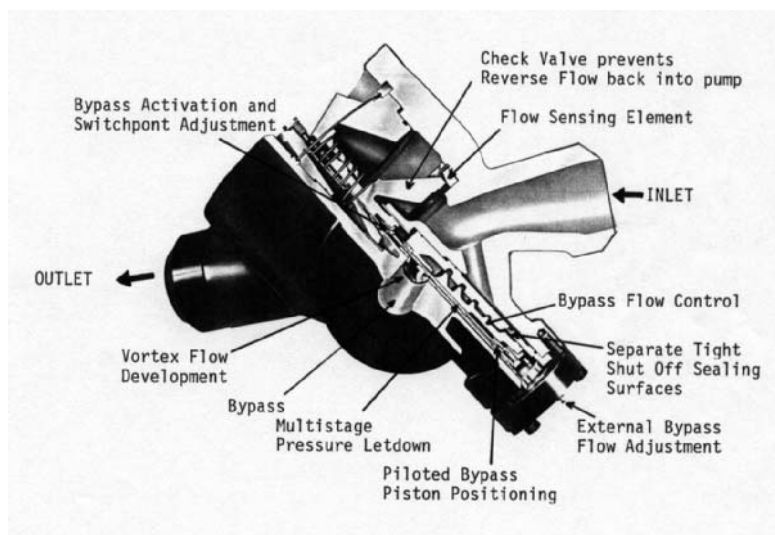


FIGURE 11 Typical in-line serviceable ARC valve

## OTHER BYPASS SYSTEM HARDWARE

---

**Orifices** In high pressure applications, the system often does not provide adequate pressure in the bypass line to prevent cavitation or flashing. Either of these conditions is undesirable because it can cause damage to both valves and the pipe system or cause a reduction in flow below the minimum desired, jeopardizing the pump protection system. All pressure-reducing valves will experience a velocity-induced recovery effect that will limit the amount of pressure drop a valve can take and cause a reduction in flow capacity.

The requirement of backpressure is generic to all pressure-reducing applications. Pressure reduction even by multiple stage cascading can minimize the requirement; however, no valve design will redefine a fluid's physical properties. This becomes especially important in modulating systems. A fixed orifice will not provide the proper backpressure at all flow levels.

As the flow in the bypass line is reduced, the orifice becomes less effective. Proper system design should be used to optimize valve pressure reduction and consider all fluid dynamic effects downstream of any pressure-reducing device. When adequate backpressure is not available downstream of a pressure reducing valve, vapor bubbles will form in the zone just downstream of the valve last stage control surface. This zone is defined as the "Vena Contracta" and represents the point of highest fluid velocity and lowest pressure.

The potential for 1) damage to downstream piping components and 2) flow reduction exists from this point. When line pressure remains below the fluid vapor pressure, any existing bubbles will remain and expand as piping friction further reduces line pressure. This can be defined as "*flashing condition*" and is characterized by a polished appearance on affected surfaces. When the line pressure drops below the fluid vapor pressure and then recovers, any entrapped vapor bubbles will collapse (implode). This is defined as a "*cavitating condition*" and is characterized by a cinder-like appearance on affected surfaces. The resolution of either condition is best addressed by eliminating vapor formation. This can be assured by the provision of adequate back pressure through the use of a fixed or variable orifice.

**Fixed Orifice** Simple, easily replaced orifices that reduce the pressure are an effective way to reduce bypass head and provide adequate backpressure in bypass systems. Several stages may be necessary, however, to break down high-pressure drops without flashing. For calculations of flow through standard-shaped orifices, see Section 8.1 and 8.2.

Coefficients of discharge for oddly shaped multistage orifices are difficult to calculate. However, manufacturers of these specialties can furnish curves of delivery as a function of pressure.

**Variable Orifice** In modulating systems, a fixed orifice will not provide the proper backpressure over a wide flow range. A backpressure regulator (BPR) has a variable orifice with a spring-loaded plunger that is designed to open at a specified differential pressure. If flow and differential pressure increase, it opens further to maintain the differential pressure and backpressure constant. Figure 12 illustrates a typical BPR construction. Figure 13 shows a standard BPR installation. The BPR is normally located as close to the receiver vessel as possible so that the correct backpressure is maintained in the entire bypass line.

**Valves, Piping, and Fittings** For cold water at low pressure, a simple power-actuated globe-type bypass valve is often adequate. In modulating bypass systems, the bypass valve must resist throttling damage, particularly if the water is hot. Staging the pressure drop in the valve is the most common way to reduce or eliminate flashing and cavitation damage to the valve trim or body. Figure 14 illustrates a typical multi-stage pressure reducing valve (PRV).

Pressure is reduced in stages to ensure that the pressure never decreases below the fluid vapor pressure. This prevents cavitation and the resultant valve damage and noise. Figure 15 illustrates typical calculations for reducing pressure in sequential stages. Refer to Chapter 7 for detailed information regarding valve sizing and selection.

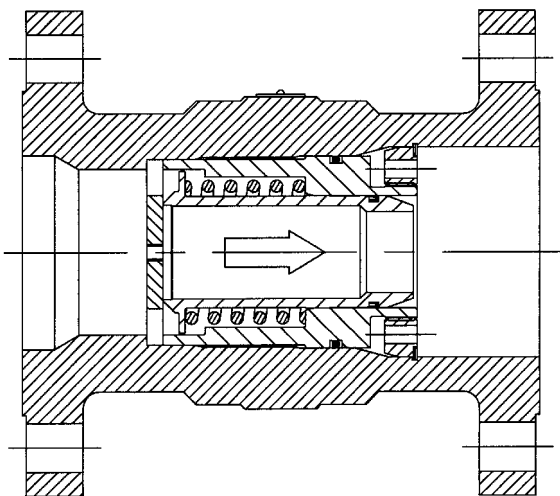


FIGURE 12 Construction of a typical backpressure regulator

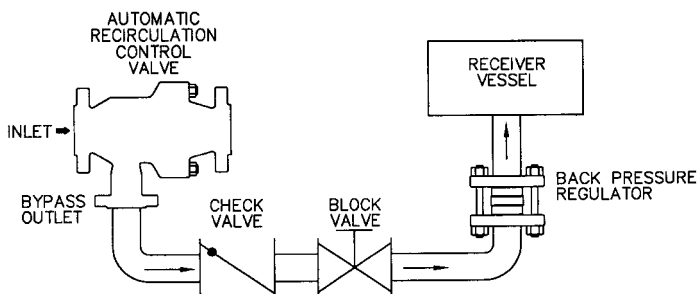


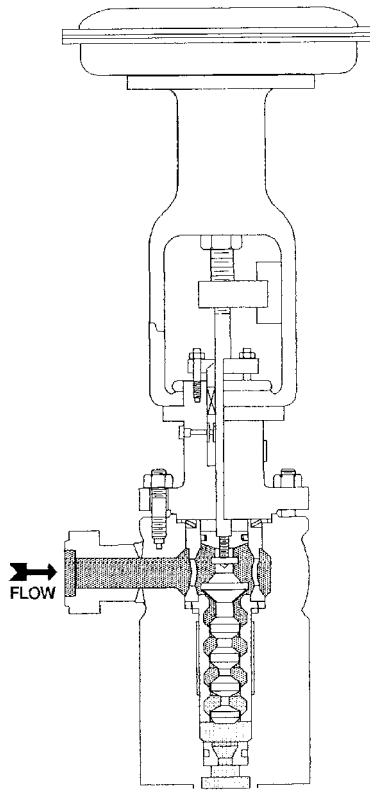
FIGURE 13 Backpressure regulator installation

Pipe material like that used for the main discharge is adequate for nearly all of the bypass line. Near the orifice and control valve outlets, however, heavier wall or higher chrome content will lengthen life. Welded piping is common for high pressures. To prevent erosion, pipe fittings (especially elbows) should not immediately follow an orifice.

**Flow Meters** Flow rate is the variable that must be measured for most automatic bypass multi-component control systems. The meter may have any type of primary element that will produce an accurate signal at the process flow for which the bypass must be controlled.

A simple orifice meter or venturi tube is commonly used. The user must have the required straight upstream and downstream pipe lengths or use flow straighteners to obtain an accurate reading. The device must be properly sized to provide both accurate indication at relatively low process flows and satisfactory pressure drop at maximum process flow conditions.

Flow meters can be located either upstream or downstream of the pump. Meters located upstream are at lower internal pressure but are larger in diameter with larger flanges. In addition, pressure drop at rated flow is important to avoid low pump *NPSH*. Meters located downstream are normally smaller but must be rated for the maximum pump discharge pressure.



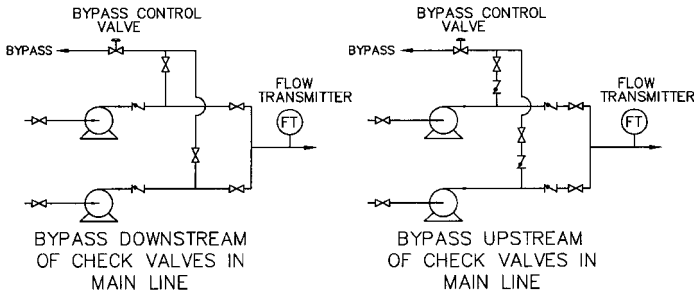
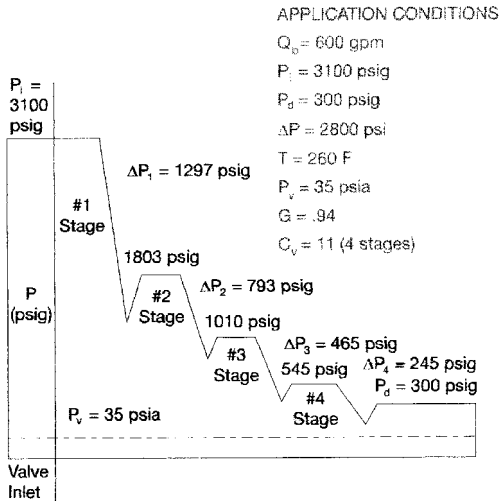
**FIGURE 14** Construction of a typical multistage pressure-reducing valve

**Controls** Controls range in complexity from a simple pressure switch that stops a pump drive motor to modulating systems that meter flow and maintain a selected minimum flow through the pump. The control system may have to provide a deadband near the opening point and be sufficiently stable to hold bypass flow nearly constant in spite of erratic flow during upsets and startup.

For example, when the primary flow-measuring element is upstream of the bypass branch off, sufficient decrease in flow will cause the bypass control to open in an “On-Off” bypass system. The main control valve, farther downstream, will then also open to maintain flow to the boiler or process. The primary element will sense the added flow and, in a simple bypass control system, close the bypass valve, initiating hunting in flow and valve action. To prevent this, the setpoint for bypass valve closing must be greater than twice the minimum bypass flow. If minimum flow is in the 30–50% range, this wastes energy during bypass. This control problem is avoided if a modulating system is installed.

### **SPECIAL BYPASS SYSTEMS**

**Pumps in Parallel** It is possible to provide a single bypass valve for two or more pumps, as shown in Figure 16. The bypass line and valve must be able to handle simultaneously



the total bypass flow of all pumps. The pumps must operate together and they must have identical head-capacity curves. If they do not, the bypass flow will differ between pumps. The pump with the lower head may have insufficient bypass flow or could be completely shut off.

In the system of Figure 16 (left), the main line check valve prevents backflow through an idle pump. If the branch off were installed as shown in Figure 16 (right), an additional check valve in each bypass connection would be necessary to stop the backflow. Therefore, this latter configuration is not recommended.

An alternative arrangement that provides better operational flexibility and pump protection is illustrated in Figure 17. Each pump is individually protected by its own automatic recirculation control (ARC) valve. Pumps can be operated individually or in any combination and the pump head characteristic curves do not have to be identical.

**Pumps in Series** A single bypass line and valve can protect two pumps in series (see Figure 18). The designer must provide for the larger of the two separately evaluated bypass flows and must take into account the heating effect of the upstream pump. The pumps cannot operate singly unless additional piping and controls are installed.



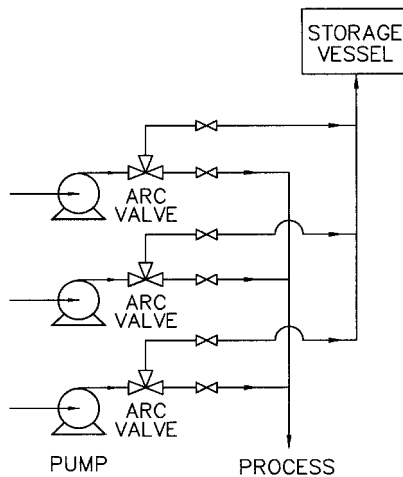


FIGURE 17 Multiple parallel pumps individually protected by ARC valves

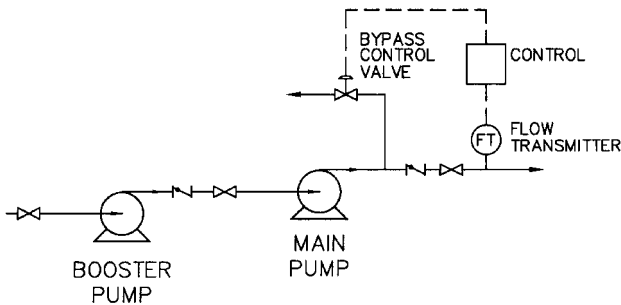


FIGURE 18 Example of a single bypass line that protects two pumps in series

## VARIABLE SPEED PUMP BYPASS CONSIDERATIONS

Large horsepower pumps are often powered by steam turbines or with motors connected through a variable speed coupling. The effect of decreased speed and discharge head is to reduce the minimum flow requirement for the pump. Therefore, if the minimum required bypass flow is calculated and sized with the pump at normal operating speed and pressure, the bypass flow will be adequate when the pump is operated at lower speeds.

**Warning** If a constant backpressure device such as a backpressure regulator is used to control bypass pressure, precautions must be taken to ensure that the pump is never operated at pressures below the BPR setting. If the pump is operated below the BPR setting, the pump will have no bypass flow and may be damaged in a short time.

In a typical boiler system, a constant speed booster pump, requiring less minimum flow than the boiler-feed pump, could be protected by the bypass flow for the variable speed boiler feed pump. The designer must determine if the booster pump bypass flow is sufficient when the high pressure feed pump is running at minimum discharge pressure.

**REFERENCES**

---

1. Dufour, J. W., and W. E. Nelson. *Centrifugal Pump Source Book*. McGraw-Hill, 1992.
2. Garay, P. N. *Pump Application Desk Book*. 2nd ed. Fairmount Press, 1992.
3. Anderson, H. H. *Centrifugal Pumps and Allied Machinery*. 4th ed. Elsevier Science Publishers Ltd., 1994.
4. Heald, C. C. "Cameron Hydraulic Data." 18th ed. Ingersoll-Dresser Pump Company, now Flowserve Corporation, 1995.

---

# SECTION 2.4

---

# CENTRIFUGAL PUMP PRIMING

---

IGOR J. KARASSIK  
C. J. TULLO

A centrifugal pump is primed when the passageways of the pump are filled with the liquid to be pumped. The liquid replaces the air, gas, or vapor in the passageways. This may be done manually or automatically.

When a pump is first put into service, its passageways are filled with air. If the suction supply is above atmospheric pressure, this air will be trapped in the pump and compressed somewhat when the suction valve is opened. Priming is accomplished by venting the entrapped air out of the pump through a valve provided for this purpose.

Unlike a positive displacement pump, a centrifugal pump that takes its suction from a supply located below the pump, which is under atmospheric pressure, cannot start and prime itself (unless designed to be self-priming, as described later in this section). At its rated capacity, a positive displacement pump will develop the necessary pressure to exhaust air from its chambers and from the suction piping. Centrifugal pumps can also pump air at their rated capacity, but only at a pressure equivalent to the rated head of the pump. Because the specific weight of air is approximately  $\frac{1}{800}$  that of water, a centrifugal pump can produce only  $\frac{1}{800}$  of its rated liquid pressure. For every 1 ft (1 m) water has to be raised to prime a pump, the pump must produce a discharge head of air of approximately 800 ft (m). It is therefore apparent that the head required for a conventional centrifugal pump to be self-priming and to lift a large column of liquid (and in some cases to discharge against an additional static liquid head) when pumping air is considerably greater than the rating of the pump. Centrifugal pumps that operate with a suction lift can be primed by providing (1) a foot valve in the suction line, (2) a single-chamber priming tank in the suction line or a two-chamber priming tank in the suction and discharge lines, (3) a priming inductor at the inlet of the suction line, or (4) some form of vacuum-producing device.

## FOOT VALVES

A foot valve is a form of check valve installed at the bottom, or foot, of a suction line. When the pump stops and the ports of the foot valve close, the liquid cannot drain back to the suction well if the valve seats tightly. Foot valves were very commonly used in early installations of centrifugal pumps. Except for certain applications, their use is now much less common.

A foot valve does not always seat tightly, and the pump occasionally loses its prime. However, the rate of leakage is generally small, and it is possible to restore the pump to service by filling and starting it promptly. This tendency to malfunction is increased if the liquid contains small particles of foreign matter, such as sand, and foot valves should not be used for such service. Another disadvantage of foot valves is their unusually high frictional loss.

The pump can be filled through a funnel attached to the priming connection or from an overhead tank or any other source of liquid. If a check valve is used on the pump and the discharge line remains full of liquid, a small bypass around the valve permits the liquid in the discharge line to be used for repriming the pump when the foot valve has leaked. Provision must be made for filling all the passageways and for venting out the air.

## PRIMING CHAMBERS

**The Single-Chamber Tank** A single-chamber primer is a tank with a bottom outlet that is level with the pump suction nozzle and directly connected to it. An inlet at the top of the tank connects with the suction line (Figure 1). The size of the tank must be such that the volume contained between the top of the outlet and the bottom of the inlet is approximately three times the volume of the suction pipe. When the pump is shut down, the liquid in the suction line may leak out, but the liquid in the tank below the suction inlet cannot run back to the supply. When the pump is started, it will pump this entrapped liquid out of the priming chamber, creating a vacuum in the tank. The atmospheric pressure on the supply will force the liquid up the suction line into the priming chamber.

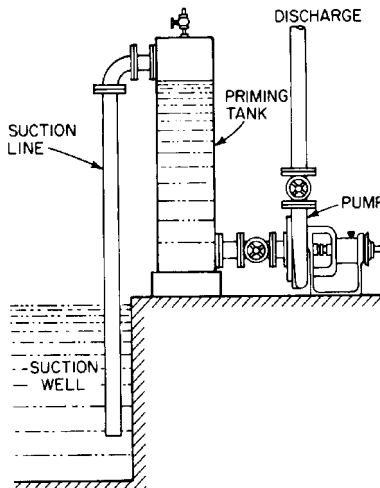


FIGURE 1 Single-chamber priming tank

Each time the pump is stopped and restarted, a quantity of liquid in the priming tank must be removed to create the required vacuum. Because of possible back siphoning, the liquid volume in the tank is reduced. Unless the priming tank is refilled, it has limited use. Automatic refilling of the priming tank cannot occur if the pump has a discharge check valve unless there is sufficient backflow from the discharge system before the check valve seats.

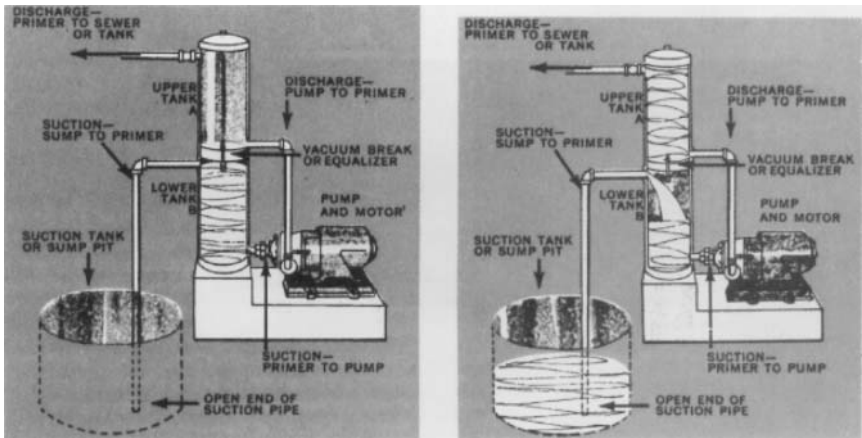
Because of their size, the use of single-chamber priming tanks is restricted to installations of relatively small pumps, usually to a 12-in (305-mm) suction line (approximately 2000 gpm [450 m<sup>3</sup>/h]).

**The Two-Chamber Tank** This type of priming tank is an improvement over the single-chamber design. It consists of integral suction and discharge chambers connected by a vacuum breaker or equalizing line. The operation and automatic refilling feature of this device are shown in Figure 2. Commercial priming chambers are readily available with proper automatic vents and other features.

## PRIMING INDUCTORS

If a separate source of liquid of sufficient capacity and pressure is available, it can be used to fill the suction line of the pump to be primed through the use of an inductor, as shown in Figure 3. For water, the pressure must be equal to about 4 lb/in<sup>2</sup> for each foot (90 kPa for each meter) of head necessary to prime the pump, measured from the lowest liquid level in the sump from which priming must be accomplished to the top of the pump. The amount of liquid necessary depends on the pressure.

Because the inductor is a positive-pressure device, leaks in the suction line or at the pump seal or stuffing box are not critical. The service liquid can be left on or turned off



### Phantom View of Primer in Use with Pump Stopped (left)

When the pump stops, the liquid in the upper chamber runs back into the pump and lower chamber of primer by gravity, thus refilling them with liquid and keeping the pump always ready for starting.

### Phantom View of Primer in Use with Pump Running (right)

When the pump starts, it draws liquid from the lower chamber and discharges it through the upper chamber. Withdrawal of liquid from the lower chamber creates a partial vacuum in this chamber, which causes the liquid in the sump or well to rise in the suction pipe and flow through the primer to the pump.

FIGURE 2 Two-chamber priming tank (Apco/Valve and Primer)

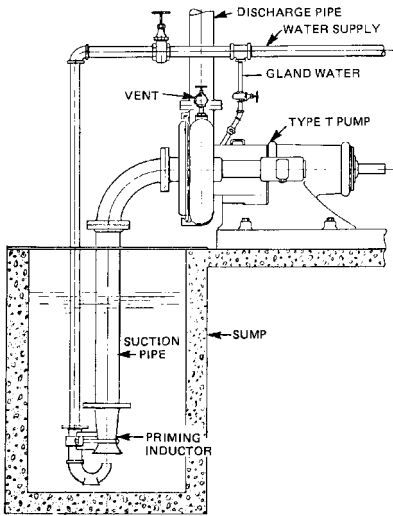


FIGURE 3 Priming inductor (Nagle Pumps)

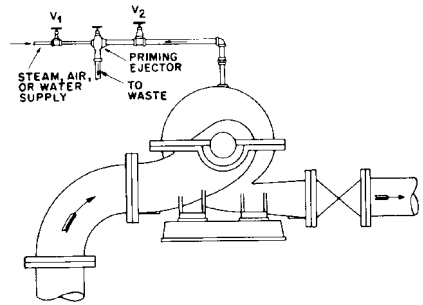


FIGURE 4 Arrangement of priming with an ejector

after pumping is initiated. If left on, the head developed by the pump (therefore the flow also) will be increased.

An additional feature of the priming inductor is that operation is possible even when the suction line is covered with sediment. When the pump and suction line are filled, back-flow results, mixing the solids and the liquid.

### TYPES OF VACUUM DEVICES

Almost every commercially made vacuum-producing device can be used with systems in which pumps are primed by evacuation of air. Formerly water-jet, steam-jet, or air-jet primers had wide application, but with the increase in the use of electricity as a power source, motor-driven vacuum pumps have become more popular.

**Ejectors** Priming ejectors work on the jet principle, typically using steam, compressed air, or water as the operating medium. A typical installation for priming with an ejector is shown in Figure 4. Valve  $V_1$  is opened to start the ejector, and then valve  $V_2$  is opened. When all the air has been exhausted from the pump, liquid will be drawn into and discharged from the ejector. When this occurs, the pump is primed and valves  $V_2$ , and  $V_1$  are closed, in that order.

An ejector can be used to prime a number of pumps if it is connected to a header through which the individual pumps are vented through isolating valves.

**Dry Vacuum Pumps** Dry vacuum pumps, which may be of either the reciprocating or the rotary oil-seal type, cannot accommodate mixtures of air and liquid. When they are used in priming systems, some protective device must be interposed between the centrifugal pump and the dry vacuum pump to prevent liquid from entering the vacuum pump. The dry vacuum pump is used extensively for central priming systems.

**Wet Vacuum Pumps** Any rotary, rotative, or reciprocating pump that can handle air or a mixture of air and liquid is classified as a wet vacuum pump. The most common type

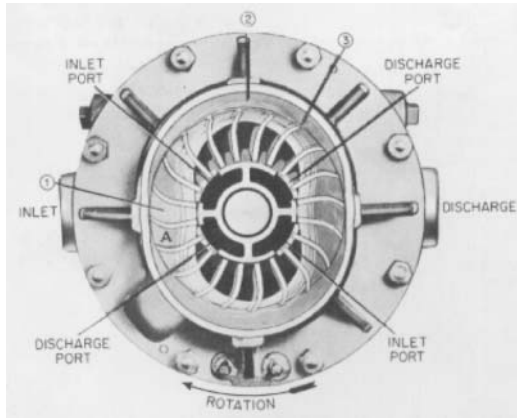


FIGURE 5 Operating principle of the Nash Hytor pump (Nash Engineering)

used in priming systems is shown in Figure 5. This is a centrifugal displacement type of pump consisting of a round, multibladed rotor revolving freely in an elliptical casing partially filled with liquid. The curved rotor blades project radially from the hub and, with the side shrouds, form a series of pockets and buckets around the periphery.

The rotor revolves at a speed high enough to throw the liquid out from the center by centrifugal force. This forms a solid ring of liquid revolving in the casing at the same speed as the rotor, but following the elliptical shape of the casing. It will be readily seen that this forces the liquid to alternately enter and recede from the buckets as the rotor at high velocity.

Referring to Figure 5 and following through a complete cycle of operation in a given chamber, we start at point A with the chamber (1) full of liquid. Because of the effect of the centrifugal force, the liquid follows the casing, withdraws from the rotor, and pulls air through the inlet port, which is connected to the pump inlet. At (2) the liquid has been thrown outwardly from the chamber in the rotor and has been replaced with air. As rotation continues, the converging wall of the casing at (3) forces the liquid back into the rotor chamber, compressing the air trapped in the chamber and forcing it out through the discharge port, which is connected with the pump discharge. The rotor chamber is now full of liquid and ready to repeat the cycle. This cycle takes place twice in each revolution.

If a solid stream of liquid circulates in this pump in place of air or of an air and liquid mixture, the pump will not be damaged but it will require more power. For this reason, in automatic priming systems using this type of vacuum pump, a separating chamber or trap is provided so liquid will not reach the pump. Liquid needed for sealing a wet vacuum pump can be supplied from a source under pressure, with the shutoff valve operated manually or through a solenoid connected with the motor control. It is, however, preferable to provide an independent sealing liquid supply by mounting the vacuum pump on a base containing a reservoir. This is particularly desirable in locations where freezing may occur, as a solution of antifreeze can be used in the reservoir.

## CENTRAL PRIMING SYSTEMS

If there is more than one centrifugal pump to be primed in an installation, one priming device can be made to serve all the pumps. Such an arrangement is called a central priming system (Figure 6). If the priming device and the venting of the pumps are automatically controlled, the system is called a central automatic priming system.

**Vacuum-Controlled Automatic Priming System** A vacuum-controlled automatic priming system consists of a vacuum pump exhausting a tank. The pump is controlled by

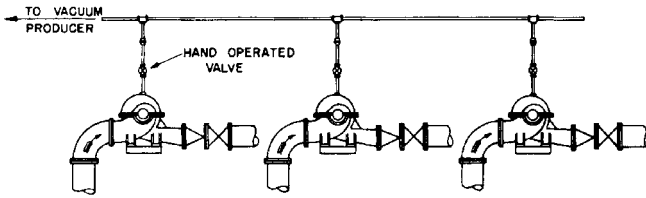


FIGURE 6 Connections for a central priming system

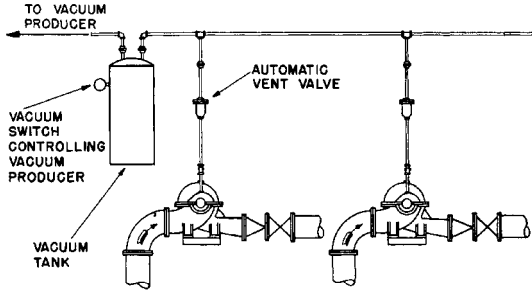


FIGURE 7 Vacuum-controlled central automatic priming

a vacuum switch and maintains a vacuum in the tank of 2 to 6 in Hg (50 to 150 mm Hg) above the amount needed to prime the pumps with the greatest suction lift. The priming connections on each pump served by the system are connected to the vacuum tank by automatic vent valves and piping (Figure 7). The vacuum tank is provided with a gage glass and a drain. If liquid is detected in the vacuum tank as the result of leakage in a vent valve, the tank can be drained. Automatic vent valves consist of a body containing a float that actuates a valve located in the upper part. The bottom of the body is connected to the space being vented. As air is vented out of the valve, water rises in the body until the float is lifted, and the valve is closed.

A typical vent valve designed basically for vacuum priming systems is illustrated in Figure 8. The valve is provided with auxiliary tapped openings on the lower part of the body for connection to any auxiliary vent points on the system—for instance, when air is to be exhausted simultaneously from the high point of the discharge volute and the high point of the suction passageways. When one or more of these vent points are points of higher pressure, such as the top of the volute of the pump, an orifice is used in the vent line to limit the flow of liquid. Otherwise, a relatively high constant flow of liquid from the discharge back to the suction would take place, causing a constant loss. Where a unit is used more or less constantly, a separate valve should be used for each venting point.

The system shown in Figure 7 is the most commonly used of central automatic priming systems. It can use either wet or dry motor-driven vacuum pumps. Most central priming systems are provided with two vacuum pumps. The usual practice is to have the control of one vacuum pump switched on at some predetermined vacuum and the control of the second switched on at a slightly lower vacuum.

Combination dry reciprocating-type vacuum pump and vacuum tank units are commercially available in various sizes. The operation of a typical unit can be explained as follows, referring to Figure 9.

The primer automatically stops and start itself to maintain a minimum vacuum in its tank at all times, regardless of whether the centrifugal pumps it serves are operating or not.

A vacuum header is run from the primer to the centrifugal pumps, and connection is made to the priming valve mounted on each pump. The vacuum in the primer tank



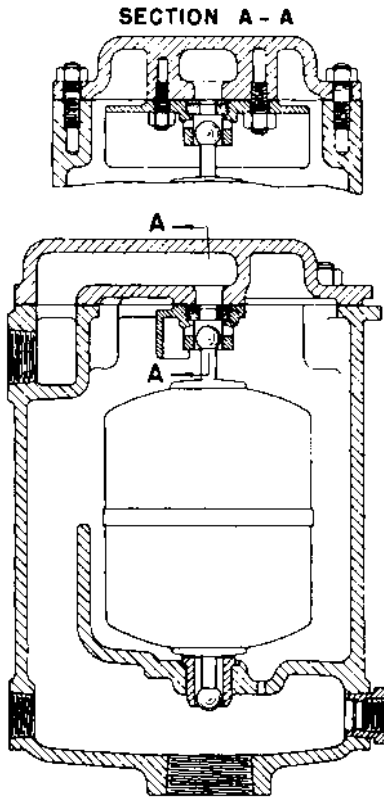


FIGURE 8 Automatic vent valve (Nash Engineering)

removes the air from the pump and suction line via the vacuum header and priming valve. Liquid rises up the suction line and fills the pump. The liquid cannot enter the vacuum header because the float mechanism in the priming valve closes when the liquid reaches it.

If, for any reason, the liquid level in the pump drops, the priming valve immediately opens and the vacuum restores the liquid level.

The pumps are thus kept permanently primed.

Automatic priming systems using ejectors are also feasible, and several such systems are commercially available.

### **SELF-CONTAINED UNITS**

Centrifugal pumps are available with various designs of priming equipment that makes them self-contained units. Some have automatic priming devices, which are basically attachments to the pump and become inactive after the priming is accomplished. Other units, which are self-priming pumps, incorporate a hydraulic device that can function as a wet vacuum pump during the priming period (see below). For stationary use, the automatically primed type is more efficient. The self-priming designs are generally more compact and are preferred for portable or semiportable use.

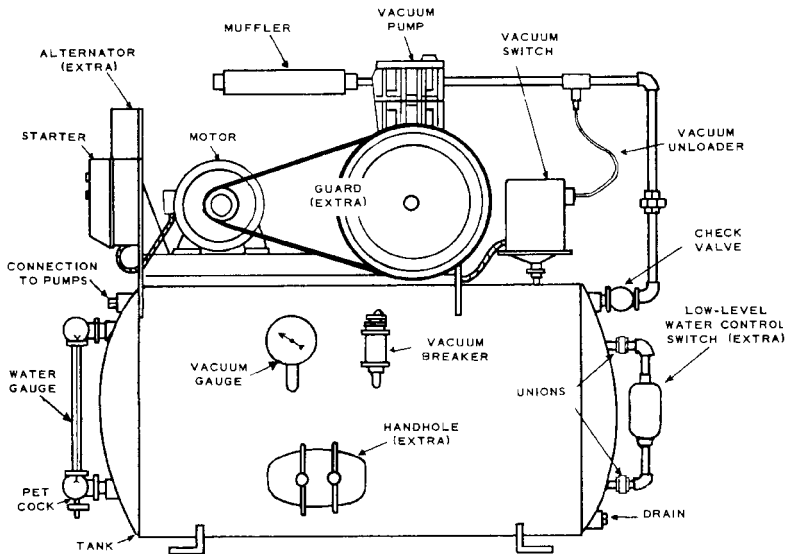


FIGURE 9 Combination dry reciprocating-type vacuum pump and vacuum tank (Apc/Valve and Primer)

An automatically primed motor-driven pump uses a wet vacuum pump either directly connected to the pump or driven by a separate motor. In a directly connected unit, as soon as the centrifugal pump is primed, a pressure-operated control opens the vacuum pump suction to atmosphere so it operates unloaded. With a separately driven vacuum pump, the controls stop the vacuum pump when the centrifugal pump is primed.

### SELF-PRIMING PUMPS

The basic requirement for a self-priming centrifugal pump is that the pumped liquid must be able to entrain air in the form of bubbles so the air will be removed from the suction side of the pump. This air must be allowed to separate from the liquid after the mixture of the two has been discharged by the impeller, and the separated air must be allowed to escape or to be swept out through the pump discharge. Such a self-priming pump therefore requires, on its discharge side, an air-separator, which is a relatively large stilling chamber, or reservoir, either attached to or built into the pump casing. Alternatively, a small air bleed line can be installed from the discharge pipe between the pump and the discharge check valve back to the suction source.

There are two basic variations of the manner in which the liquid from the discharge reservoir makes the pump self-priming: (1) recirculation from the reservoir back to the suction and (2) recirculation within the discharge and the impeller itself.

**Recirculation to Suction** In such a pump, a recirculating port is provided in the discharge reservoir, communicating with the suction side of the impeller. Before the first time the pump is started, the reservoir is filled. As the pump is started, the impeller handles whatever liquid comes to it through the recirculating port plus a certain amount of air from the suction line. This mixture of air and liquid is discharged to the reservoir, where the two elements are separated, the air passing out of the pump discharge and the liquid returning to the suction of the impeller through the recirculation port. This operation continues until all the air has been exhausted from the suction line.

The vacuum thus produced draws the liquid from the suction supply up the suction piping and into the impeller. After all the air has been exhausted and liquid is drawn into the pump, the pressure difference between the pump body and the inlet causes the priming valve, which permits communication between discharge and suction passages, to close. It is essential that the reservoir in the suction side remain filled with liquid when the pump is stopped, so the pump is ready to restart. This is accomplished by incorporating either a valve or some sort of trap between the suction line and the impeller.

Pumps with recirculation to suction are seldom used today, and by far the most common arrangement is that with recirculation at the discharge.

**Recirculation at Discharge** This form of priming is distinguished from the preceding method by the fact that the priming liquid is not returned to the suction of the pump but mixes with the air either in the impeller or at its periphery. The principal advantage of this method, therefore, is that it eliminates the complexity of internal valve mechanisms.

One such self-priming pump is illustrated in Figure 10. An open impeller (A) rotates in a volute casing (B), discharging the pumped liquid through passage C into the reservoir (D). When the pump starts, the trapped liquid carries entrained air bubbles from the suction to the discharge chamber. There, the air separates from the liquid and escapes,

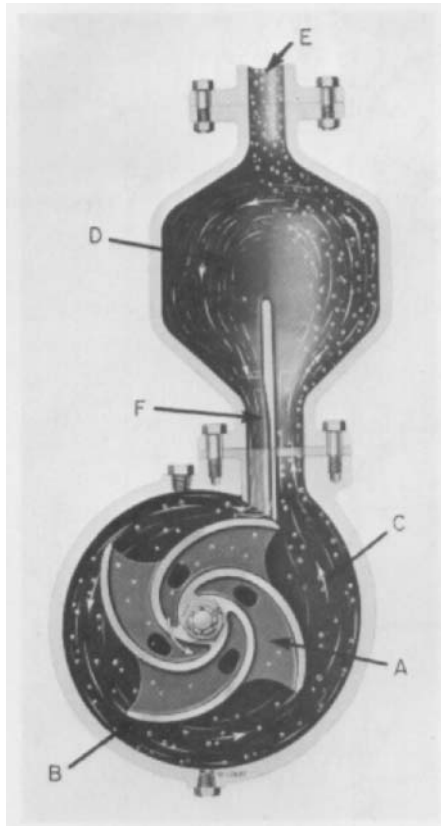


FIGURE 10 Self-priming pump with recirculation at discharge (Flowsolve Corporation)

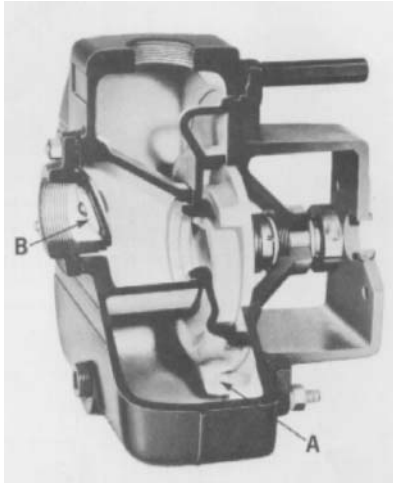


FIGURE 11 Self-priming pump with recirculation at discharge (Peabody Barnes)

whereas the liquid in the reservoir returns to the impeller through the recirculation port (F), reenters the impeller and, after mixing once more with air bubbles, is discharged through passage C. This operation is repeated continuously until all the air in the suction line has been expelled. After the pump is primed, a uniform pressure distribution is established around the impeller, preventing further recirculation. From this moment on, the liquid is discharged into the reservoir bath at C and at F.

Figure 11 illustrates another form of self-priming pump with recirculation at the discharge. In this arrangement, the return of the liquid to the impeller periphery takes place through a communicating passage (A) located at the bottom of the pump casing. After the pump is primed, liquid is delivered into the reservoir at the discharge both through its normal volute discharge and through port A. In the pump illustrated in Figure 11, a check valve at the pump suction (B) acts to prevent the draining of the pump after it has been stopped.

**Regenerative Turbine Pumps** Because these pumps can handle relatively large amounts of gas, they are inherently self-priming as long as sufficient liquid remains in the pump to seal the clearance between the suction and discharge passages. This condition is usually met by building a trap in the pump suction.

## SPECIAL APPLICATIONS

**Systems for Sewage Pumps** A pump handling sewage or similar liquids containing stringy material can be equipped with automatic priming, but special precautions must be used to prevent carry-over of the liquid into the vacuum-producing device.

One approach is to use a tee on the suction line immediately adjacent to the pump suction nozzle, with a vertical riser mounted on the top outlet of the tee. This riser is blanked at the top, thus forming a small tank. The top of the tank is vented to a vacuum system through a solenoid valve. The solenoid valve in turn is controlled electrically through electrodes located at different levels in the tank. The solenoid valve closes if the liquid reaches the top electrode and opens if the liquid level falls below the level of the lower electrode.

Another solution permits the use of an automatic priming system with a separate motor-driven vacuum pump controlled by a discharge-pressure-actuated pressure switch. An inverted vertical loop is incorporated in the vacuum pump suction line to the pump

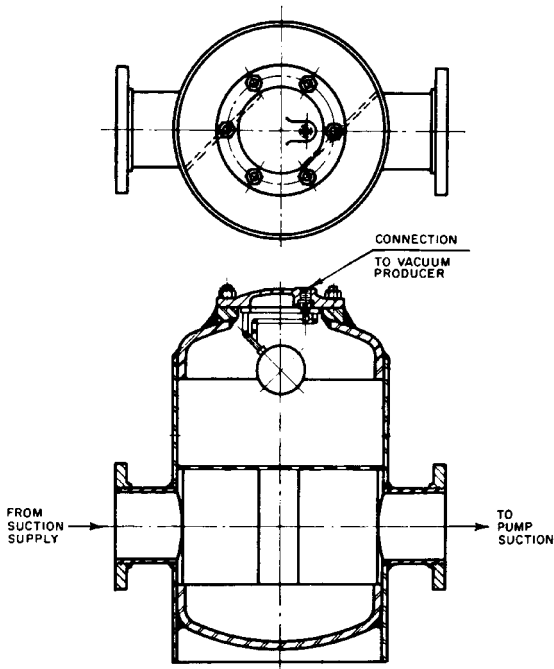


FIGURE 12 Air-separating chamber

being primed. This prevents the sewage from being carried over into the vacuum pump because this pump shuts down before the liquid reaches the top of the loop.

**Systems for Air-Charged Liquids** Some types of liquid have considerable dissolved gas that is liberated when the pump handles a suction lift. In such installations, an air-separating tank (also called a *priming tank* or an *air eliminator*) should be used in the suction line. One type (Figure 12) uses a float-operated vent valve to permit the withdrawal of air or other gas. Another common arrangement uses a float valve mounted on the side of the tank to directly control the starting and stopping of the vacuum pump. Unless the air-separating tank is relatively large and the vacuum pump is not oversized, there is danger of frequent starting and stopping of the vacuum pump in such a system. When sand is present as an impurity in the liquid, the air-separating tank can be made to also function as a sand trap.

**Systems for Units Driven by Gasoline or Diesel Engines** An automatic priming system using motor-driven vacuum pumps can be used for centrifugal pumps driven by diesel engines if a reliable source of electric power is available in the station. An auxiliary vacuum pump driven by a gasoline engine might be desirable for emergency use in case of electric power failure. Alternatively, a direct-connected wet vacuum pump with controls similar to those used in motor-driven automatically primed units is very satisfactory.

The choice of the priming device for a gasoline-engine centrifugal pump depends on the size of the pump, the required frequency of priming, and the portability of the unit. Most portable units are used for relatively low heads and small capacities, for use in pumping out excavations and ditches, for example. Self-priming pumps of various types are most satisfactory for this service and are preferable to regular centrifugal pumps.

It is possible to utilize the vacuum in the intake manifold of a gasoline engine as a means of priming or keeping the pump primed. The rate at which the air can be drawn

from the pump in this manner is relatively low, so many of these units use foot valves. They are initially primed by filling the pump manually. Provision must be made to prevent liquid from being drawn over into the manifold.

### TIME REQUIRED FOR PRIMING

The time required to prime a pump with a vacuum-producing device depends on (1) the total volume to be exhausted, (2) the initial and final vacuums, and (3) the capacity of the vacuum-producing device over the range of vacuums that will exist during the priming cycle. The calculations for determining the time necessary to prime a pump are complicated. To permit close approximations, jet primers are usually rated in net capacity for various lifts. It is necessary to divide the volume to be exhausted by the rating to obtain the approximate priming time. Unless such a simplified method is available, the selection of the size of a primer is best left to the vendor of the equipment.

Central automatic priming systems are usually rated for the total volume to be kept primed. The time initially required to prime each unit served by the central system is not usually considered, as the basic function of the system is to keep the pumps primed and in operating condition at all times.

### PREVENTION OF UNPRIMED OPERATION

Various controls may be used to prevent the operation of a pump when it is unprimed. These controls depend upon the type of priming system used. For many installations, a form of float switch in a chamber connected with the suction line is used. If the level in the chamber is above the impeller eye of the pump, the float switch control allows the pump to operate. If the liquid falls below a safe level, the float switch acts through the control to stop the pump, to prevent its being started, to sound an alarm, or to light a warning lamp. Such a valve and switch are illustrated in Figure 13.

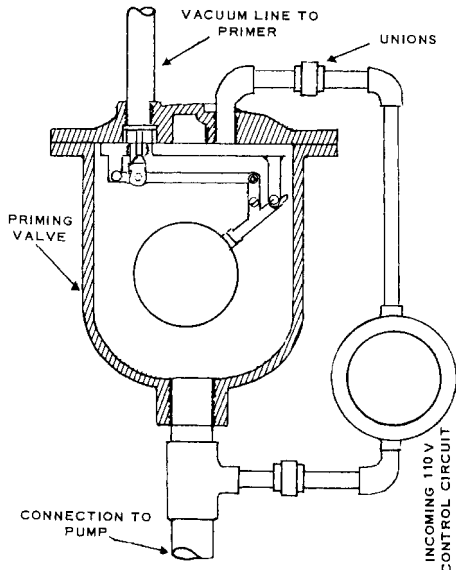


FIGURE 13 Priming valve with liquid level control switch (Apco/Valve and Primer)

**GENERAL**

---

Because a great number of automatic priming devices and systems are available, care should be taken to use the type or variation best suited to the application. The discussion of priming in this section does not, of course, cover all makes and modifications available for every specific application.

An automatic priming system will often allow units to be operated with excessive air leakage into the suction lines. This is poor practice because it requires the operation of the vacuum producer for greater periods of time than normally necessary.

**FURTHER READING**

---

Apco/Valve and Primer Corp. *Automatic Pump Primers*, Technical Bulletin 721, Schaumburg, IL, 1978.

Hrivnak, S. J. "Why Doesn't Your Self-Priming Pump Work?" *Pumps and Systems Magazine*, June, 1999.

Karassik, I. J., and Carter, R. Chap. 21 in *Centrifugal Pumps: Selection, Operation, and Maintenance*. McGraw-Hill: New York, 1960.

# DISPLACEMENT PUMPS



---

# SECTION 3.1

---

# POWER PUMP THEORY

---

WILLIAM K. CHAPLIS  
FREDERIC W. BUSE

A power pump is a positive displacement machine consisting of one or more cylinders, each containing a piston or plunger. The pistons or plungers are driven through slider-crank mechanisms and a crankshaft from an external source. The capacity of a given pump is governed by the rotational speed of the crankshaft.

Unlike a centrifugal pump, a power pump does not develop pressure; it only produces a flow of fluid. The downstream process or piping system produces a resistance to this flow, thereby generating pressure in the piping system and discharge portion of the pump. The flow fluctuates at a rate proportional to the pump speed and number of cylinders. The amplitude of the fluctuations is a function of the number of cylinders. In general, the greater the number of cylinders, the lower the amplitude of the flow variations at a specific rpm.

All power pumps are capable of operating over a wide range of speeds, thereby making it possible to produce a variable capacity when coupled to a variable speed drive. Each pump has maximum suction and discharge pressure limits that, when combined with its maximum speed, determine the pump's power rating. The pump can be applied to power conditions that are less than its maximum rating but at a slight decrease in mechanical efficiency.

The power pump is a positive displacement device. When operating, it will continue to deliver flow independent of the pressure in the discharge piping system. Unlike a centrifugal pump, a power pump will not "deadhead" or "go back on its curve" in response to increasing discharge pressure. When this pressure exceeds the design limits of the pump, mechanical failure—often catastrophic—will result. For this reason, all piping systems incorporating power pumps must have discharge pressure relief devices to limit the pressure in the piping system and avoid pump failure. These devices must be located between the discharge connection on the pump and the first isolation valve in the piping system.

This section has been organized to provide sufficient power pump theory to properly select a pump for most applications. It is recognized that the proper pump metallurgy for the pumped fluid must be used, but due to the vast number of possible fluids, selection of pump metallurgy is outside the scope of this section.

The subject of Net Positive Suction Head (NPSH) is mentioned in several places in this section and is covered in more detail in Section 3.4, "Displacement Pump Performance, Instrumentation, and Diagnostics." For basic power pump selection, it is only necessary to understand that the NPSH available from the suction system must be sufficiently above the NPSH required by the pump to operate properly.

### SELECTION THEORY

---

**Power** Brake horsepower (bhp) is a function of a pump's capacity, differential pressure, and mechanical efficiency. It is an essential criterion for selecting the drive components but is not valuable for pump selection. A large pump operating well below its design rating can meet the same horsepower requirements as a smaller pump running at a higher speed. Unless the application requires a derated pump, it is usually more economical to select a pump at the upper end of its design rating.

The brake horsepower for the pump is

$$\text{In USCS units} \quad bhp = Q \times Ptd / 1714 \times ME$$

$$\text{In SI units} \quad kW = Q \times Ptd / 36 \times ME$$

where  $Q$  = delivered capacity, gpm ( $m^3/h$ )

$Ptd$  = differential pressure (discharge – suction), lb/in<sup>2</sup> (bar)

$ME$  = mechanical efficiency, %

NOTE: One bar equals  $10^5$  Pa.

**Capacity** The capacity  $Q$  is the total volume of fluid delivered per unit of time. This fluid includes liquid, entrained gases, and solids at the specified conditions.

**Displacement** Displacement  $D$ , gpm ( $m^3/h$ ), is the calculated capacity of the pump with no slip losses. For single-acting plunger or piston pumps, this is

$$\text{In USCS units} \quad D = A \times m \times n \times s / 231$$

$$\text{In SI units} \quad D = A \times m \times n \times s \times 6 \times 10^{-5}$$

where  $A$  = cross-sectional area of plunger or piston, in<sup>2</sup> ( $mm^2$ )

$m$  = number of plungers or pistons

$n$  = rpm of pump

$s$  = stroke of pump, in (mm) (half the linear distance the plunger moves in one revolution)

$$231 = \text{in}^3/\text{gal}$$

For double-acting plunger or piston pumps, this is

$$\text{In USCS units} \quad D = (2A - a)m \times n \times s / 231$$

$$\text{In SI units} \quad D = (2A - a)m \times n \times s \times 6 \times 10^{-5}$$

where  $a$  is the cross-sectional area of the piston rod, in<sup>2</sup> ( $mm^2$ ).

**Pressure** The pressure  $Ptd$  used to determine brake horsepower is the differential pressure or discharge pressure minus the suction pressure. In most applications, the suction pressure is small relative to the discharge pressure. However, when pumping some compressible liquids, such as methane and propane, the suction pressure may be 20 to 30% of the discharge pressure. For accurate brake horsepower calculations, always include the suction pressure. Figure 1 shows a typical performance curve for a power pump.

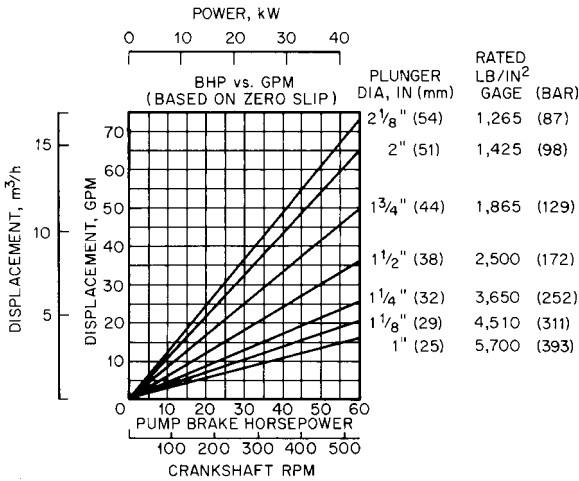


FIGURE 1 Typical power pump performance: brake horsepower versus gallons per minute (kilowatts versus m<sup>3</sup>/h) based on zero slip (Flowsolve Corporation)

TABLE 1 Slip in a pump with a plate valve

Centistokes	100	1,000	2,000	6,000	10,000	12,000
Slip, %	8	8.5	9.5	20	41	61

TABLE 2 Slip as a function of pump speed and pressure

Pressure, lb/in <sup>2</sup> (bar)	Slip, %		
	At 440 rpm	At 390 rpm	At 365 rpm
4000 (275)	11	22	34
3000 (207)	9	20	31
2000 (138)	7	18	30
1000 (69)	7	15	27.5

**Slip** Slip ( $S$ ) is the loss of capacity due to internal and external pump leakage. External leakage occurs primarily through the stuffing box via the packing. Internal leakage is primarily the backflow past the suction and discharge valves. Backflow occurs when a valve remains open for a fraction of a second as the plunger or piston reverses direction. A small amount of leakage may occur across the piston in a double acting pump from the high pressure side to the low pressure side. Slip is expressed as a percentage loss of the suction capacity and is typically 1% to 4%:

$$S = B + V + L$$

where  $S$  = Slip, %

$B$  = Leakage through the stuffing box

$V$  = Backflow across the valves

$L$  = Internal leakages

Fluid viscosity, pump speed, and discharge pressure can all have an effect on slip, which is shown in Tables 1 and 2.

**Mechanical Efficiency** The mechanical efficiency of a power pump is

$$\text{In USCS units} \quad ME = \text{power out/power in} = P_{out}/P_{in} = Q \times Pdt/1714 \times P_{in}$$

$$\text{In SI units} \quad ME = \text{power out/power in} = P_{out}/P_{in} = Q \times Pdt/36 \times P_{in}$$

where  $P_{in}$  is the input power from the driver, bhp (kW).

The mechanical efficiency of a power pump is the sum of all the frictional losses in the fluid and power ends. These include the plungers and packing, the crossheads, the rod seals, and the bearings. The efficiency of a single acting pump often exceeds 90%, while a double-acting piston pump will be 88% due to the additional piston and rod seals. If the pump is equipped with internal gearing, an additional 2% loss is common.

Most power pumps are designed to accept a range of plunger or piston sizes. When the larger plungers are used, the increased diameter of the packing/seals and plunger/liners will result in higher frictional losses than with smaller components. As a rule, doubling the plunger/piston diameter will decrease the mechanical efficiency by 8%. Mechanical efficiency is also affected by speed and, to a lesser extent, by developed pressure, as indicated in Tables 3 and 4.

**Speed** Pump speed, or, more correctly, stroke rate, is one of the most critical selection criteria for power pumps. The rotating and reciprocating parts of the power end, as designated, are often capable of speeds twice that of the actual pump rating. The maximum pump speed is determined by the design of the fluid end, the hydraulic capability of the anticipated suction system, and the required life of the plungers, packing, and valves. Most power pump standards limit the plunger speed from 140 to 280 ft/min (0.71 to 1.42 m/s). The plunger speed is

$$\text{In USCS units} \quad Sp = s \times n/6$$

$$\text{In SI units} \quad Sp = s \times n/30,000$$

where  $Sp$  = plunger or piston speed, ft/min (m/s).

$s$  = stroke of the pump, in (mm) (half of the linear distance the plunger or piston moves in one revolution)

$n$  = rpm of pump

All pumps have a minimum speed limit, usually determined by a decrease in the adequate lubrication to the bearings in the power end.

**Volumetric Efficiency** Volumetric efficiency (VE) is the ratio of the discharge volume to the suction volume, expressed as a percentage, plus the slip. It is proportional to the ratio  $r$  and the developed pressure where  $r$  is the ratio of the internal volume of fluid between valves when the plunger or piston is at the top of the peak of its back stroke ( $C + D$ ) to the plunger or piston displacement ( $D$ ) (see Figure 2).

**TABLE 3** The effect of speed on mechanical efficiency at a constant developed pressure

% of full speed	44	50	73	100
ME, %	93.3	92.5	92.5	92.5

**TABLE 4** The effect of pressure on mechanical efficiency at constant speed

% of full-load developed pressure	20	40	60	80	100
ME, %	82	88	90.5	92	92.5

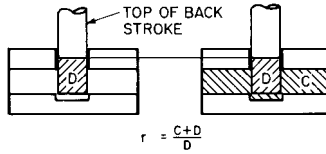


FIGURE 2 The ratio  $r$  (Flowserve Corporation)

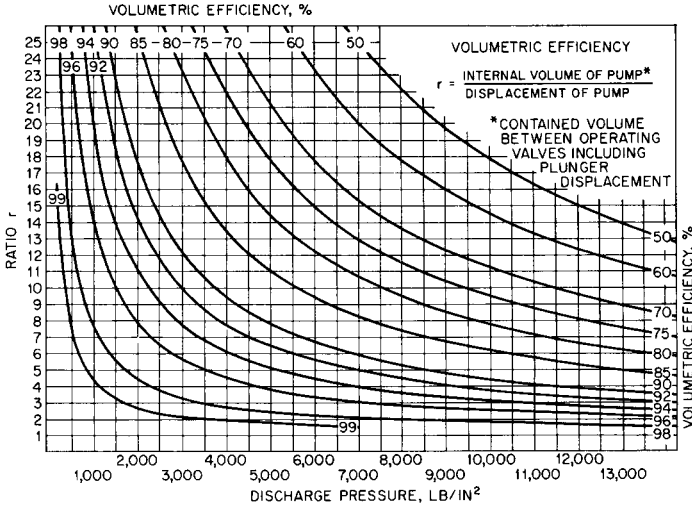


FIGURE 3 Volumetric efficiency (Flowserve Corporation) ( $\text{lb/in}^2 \times 0.69 = \text{bar}$ )

Since the discharge volume cannot be readily measured at discharge pressure, it is taken at suction pressure. Taking the discharge volume at the suction pressure results in a higher volumetric efficiency than using the calculated discharge volume at discharge pressure because of fluid compressibility. Compressibility becomes important when pumping water or other liquids over 6000  $\text{lb/in}^2$  (414 bar), and it should be taken into consideration when determining the actual delivered capacity into the discharge system.

Figure 3 shows the approximate volumetric efficiency for water (not including slip). Based on the expansion back to suction capacity,

$$VE = (1 - Ptd \times \beta \times r)/(1 - Ptd \times \beta) - S$$

Based on discharge capacity,

$$VE = (1 - Ptd \times \beta \times r) - S$$

where  $\beta$  is the compressibility factor of the liquid being pumped. Figure 4 shows approximate values of  $\beta$  for various liquids.

When the compressibility factor is not known, but the suction and discharge density can be determined in pounds per cubic foot, the following equations can be used for calculating VE:

Based on suction capacity,

$$VE = r - (p_d/p_s)(r - 1) - S$$

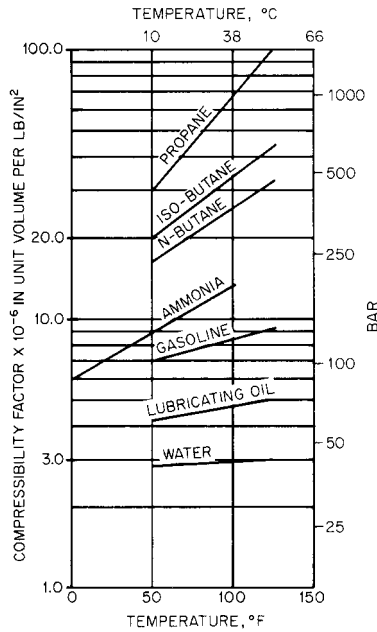


FIGURE 4 Compressibility factor (Flowsolve Corporation) (bar  $\times 14.5 = \text{lb/in}^2$ )

Based on discharge capacity,

$$VE = 1 - r(1 - p_s/p_d) - S$$

where  $p_s$  = suction density

$p_d$  = discharge density

$S$  = slip

**Torque** The average torque required by a power pump is independent of the pump speed, assuming the suction and discharge pressures are held constant. This means that the pump is a “constant torque” device and, unlike a centrifugal pump, will have a flat speed-torque curve. The torque required at the input shaft is as follows:

In USCS units 
$$M = p \times 5250/n$$

In SI units 
$$M = p \times 9.549/n$$

where  $M$  = pump torque, lb-ft ( $\text{N} \cdot \text{m}$ )

$n$  = speed, rpm

$p$  = power, bhp (kW)

Break-away torque, or start-up torque, is the torque required to initiate the motion of the pump to enable it to accelerate to a constant speed. If the pump is started against an open bypass to pump suction, the torque requirement is 25% of the running torque. If the pump is started against full discharge pressure, the torque requirement is 125% of the running torque. When selecting a drive system, the break-away torque of the pump must be considered. Special “high torque” motors are often required if the pump is to be started under the load.

**TABLE 5** The pulses per revolution and pulse amplitude for various pump types

Pump Type	No. of Cylinders	Pulses per Rev.	Pulse Amplitude
Duplex, double-acting	4	8	+24% - 22%
Triplex, single-acting	3	6	+ 6% - 17%
Quintuplex, single-acting	5	10	+ 2% - 5%
Septuplex, single-acting	7	14	+1.2% - 2.6%
Nonoplex, single-acting	9	18	+0.6% - 1.5%

**TABLE 6** Guidelines for acceptable plunger speeds

Fluid	Plunger Speed, ft/min (m/s)
Cold water	315-354 (1.6-1.8)
Hot water 140-194 °F (60-90 °C)	217-256 (1.1-1.3)
Hot water over 194 °F (90 °C)	157-217 (0.8-1.1)
Salt water	236-276 (1.2-1.4)
Cold oil	315-354 (1.6-1.8)
Hot oil	256-295 (1.3-1.5)
Crude oil	217-276 (1.3-1.5)
Liquid ammonia	197-236 (1.0-1.2)
Carbamate	138-158 (0.7-0.8)
Slurry	158-197 (0.8-1.0)
Fatty acid	236-295 (1.2-1.5)
Light hydrocarbons	177-236 (0.9-1.2)
Glycol	256-295 (1.3-1.5)
High viscosity liquids	138-197 (0.7-1.0)

If a variable frequency drive (VFD) is used for pump speed/capacity control, torque fluctuations or pulsations may require the drive manufacturer to provide special electronic dampening circuits. The normal pulsating flow of the pump causes the input power to fluctuate at approximately the same magnitude as the flow pulses. The frequency of these pulses per revolution of the crankshaft is twice the number of cylinders (see Table 5).

If the pump has internal gearing, or if the pump is being driven by an external gear reducer, the torque pulsation values listed should be divided by the gear ratio.

**Derating** Power pumps can be derated in order to achieve acceptable performance or part life in a variety of special applications. The most common derating is pump speed. Experience has shown that the life of fluid-end expendable parts, such as plungers, packing, and valves, can be extended if the pump speed/plunger velocity is reduced when pumping certain fluids. Some guidelines for acceptable plunger speeds are shown in Table 6.

Pumping high-viscosity fluids may also require the speed of a power pump to be derated. Some attempts have been made to establish standards for speed derating as a function of the fluid viscosity. Unfortunately, these methods have been based on power pump designs that were established for water or similar low-viscosity services. If a pump has been designed specifically for a high-viscosity service, only moderate speed derating may be required. Generally, pumps designed with large internal fluid passages, low-valve velocities, and larger plungers or pistons will need less derating.

Power pumps should be derated for a rod load if system or process "upsets" cannot be avoided. These are usually applications where the gas content of the pumped fluid can lead to abnormal pressure pulsations or cavitations in the fluid cylinder.

## FLUID END THEORY

**Pumping Cycle** Unlike the relatively smooth, continuous flow of fluid through a centrifugal pump, the flow of fluid through a power pump occurs in a transitory dynamic condition called a *pumping cycle*. The event that initiates this cycle is the linear movement of the plunger or piston. In Figure 5,  $r$  is the radius of the crank in feet (meters),  $L$  is the length of the connecting rod in feet (meters),  $C$  equals  $L/r$ , and  $\omega$  equals  $(2\pi/60) \times \text{rpm}$ . Thus,  $X$ , the linear movement of the piston or plunger is

$$X = r \left[ 1 - \cos \theta + L \left( 1 - \sqrt{1 - \frac{r^2}{L^2} (\sin \theta)^2} \right) \right]$$

As the plunger (or piston) withdraws from the fluid cylinder or pumping chamber, the volume of the cylinder increases. The pressure in the cylinder decreases in response to the increased volume. Since most of the fluids handled by power pumps are relatively incompressible, very little plunger movement is required to cause a pressure drop. When the cylinder pressure drops sufficiently below suction pressure, the differential pressure begins to open the suction valve. The valve opens gradually and smoothly at the start of the suction stroke because the velocity and acceleration of the plunger are small.

Fluid flows through the suction valve assembly, following the plunger and filling the cylinder. As the plunger decelerates at the end of the suction stroke, the suction valve gradually returns to its seat. Ideally, the suction valve is completely closed as the plunger comes to a stop.

The motion of the slider-crank mechanism causes the plunger to reverse direction and start its discharge stroke. The fluid trapped in the fluid cylinder is compressed until the cylinder pressure exceeds the discharge pressure by an amount sufficient to begin to open the discharge valve. As with the suction valve, the discharge valve continues to open until it reaches its travel limit or until the velocity of fluid through the valve becomes constant. As the plunger decelerates, the valve moves back toward its seat. Again, ideally, the discharge valve closes when the motion of the plunger stops.

The number of pumping cycles in a single revolution of the crankshaft is the same as the number of cylinders in the pump. Every cylinder will “pump” in a sequence determined by the “firing order” of the crankshaft. The cylinders are arranged in parallel, with each one discharging into a common discharge manifold. In industry terms, the pump is usually identified by the number of plungers or pistons on the crankshaft. They are the same for single- or double-acting pumps (see Table 7).

**Pulsations** The pulsating characteristics of the fluid flowing into and out of power pumps are significantly influenced by the number of plungers or pistons. Discharge flow pulsations are the most critical because of the high energy potential generated when the system resistance reacts with the flow to create pressure. Since the magnitude of the discharge pulsation is mostly affected by the number of cylinders, increasing the number of cylinders will reduce the flow pulsations.

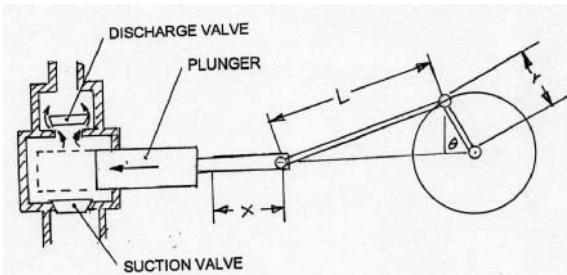
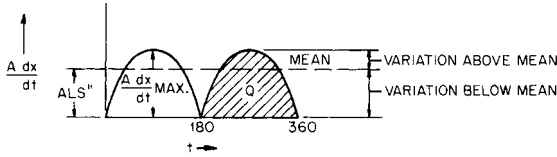
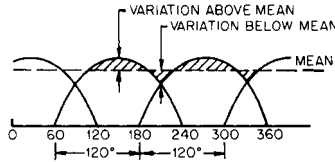


FIGURE 5 Slider-crank mechanism



**TABLE 7** Industry terms for the number of plungers or pistons

Number	Term
1	Simplex
2	Duplex
3	Triplex
4	Quadruplex
5	Quintuplex
6	Sextuplex
7	Septuplex
9	Nonuplex

**FIGURE 6** The discharge rate for a single double-acting pump (Flowsolve Corporation)**FIGURE 7** The discharge rate for a triplex single acting pump (Flowsolve Corporation)

The acceleration and velocity of the plunger or piston will determine the rate that the fluid is discharged from the cylinder. The approximate velocity of the plunger or piston is

$$S = \frac{dx}{dt} = r \left( \sin \theta + \frac{\sin 2\theta}{2C} \right) \omega$$

The approximate acceleration of the plunger or piston is

$$C_p = \frac{d^2x}{dt^2} = r \left( \cos \theta + \frac{\cos 2\theta}{C} \right) \omega^2$$

The momentary rate of discharge capacity is the cross-sectional area  $A$  of the plunger or piston times velocity:

$$\text{For single-acting plunger or piston} \quad A = 0.785 \times D^2$$

$$\text{For double-acting piston} \quad A - a = 0.785 (D^2 - d^2)$$

The total discharge  $Q$  is equal to  $ALS'$ , where  $S'$  is the number of effective strokes in a given time. The quantity  $Q$  is the area of the curve, the mean height of which is

$$\text{Total } Q/t = ALS'/t = ALS''$$

where  $S''$  is the number of strokes per second and  $t$  is time in seconds.

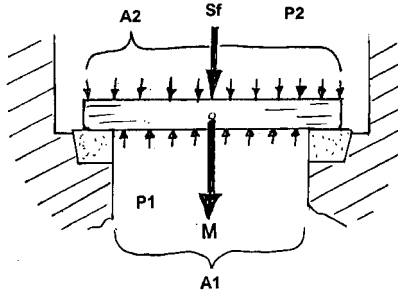
Figures 6 and 7 show discharge rates for two types of pumps. Tables 8 and 9 show how variations from the mean are related to the change in the number of plungers with a  $C$  of

**TABLE 8** The effect of the number of plungers on variations in capacity from the mean ( $C$  is approx. 6:1)

Type	Number of Plungers	% Above Mean	% Below Mean	Total %	Plunger Phase
Duplex	2	24	22	46	180 deg.
Triplex	3	6	17	23	120 deg.
Quadruplex	4	11	22	33	90 deg.
Quintaplex	5	2	5	7	72 deg.
Sextuplex	6	5	9	14	60 deg.
Septuplex	7	1	3	4	51.5 deg.
Nonuplex	9	1	2	3	40 deg.

**TABLE 9** The effect of change in  $C$  on variations in capacity from the mean for a triplex pump

$C$	% Above Mean	% Below Mean	Total %
4:1	8.2	20.0	28.2
5:1	7.6	17.6	25.2
6:1	6.9	16.1	23.0
7:1	6.4	15.2	21.6



**FIGURE 8** Force balance of a typical valve

approximately 6:1. This shows that pumps with an even number of cylinders have a higher flow variation than pumps with an odd number of cylinders. Table 9 shows the variations in a triplex with changes in  $C = L/R$ .

**Valves** A pump valve in its simplest form is a free-moving plug that is opened when the force of the liquid below the valve exceeds the force of the liquid above it. When the force above the valve becomes greater than the lower, the plug closes and forms an effective seal to fluid “backflow” and pressure loss. If the valve does not perform this function efficiently, the performance of the pump can be degraded to the point where no flow is produced.

A valve will be in equilibrium when the forces above and below the valve are balanced (see Figure 8):

$$\text{Equilibrium} = P_1 \times A_1 = P_2 \times A_2 + S_f + M$$

where  $P$  = the pressure below the valve

$A$  = the area below the valve exposed to  $P$

$P$  = the pressure above the valve

$A$  = the area above the valve exposed to  $P$

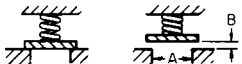
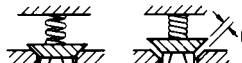
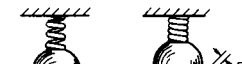

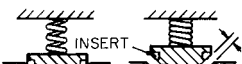
$S_f$  = the force of the valve spring ( if any)

$M$  = the mass of the valve and half the mass of the spring

The significance of this simple equation becomes apparent when you remember that the valve is operating in a dynamic environment of constantly changing pressures in a time frame that is measured in tenths of a second. Add to that the requirement that the valve must pass a volume of fluid in each opening cycle with minimal pressure drop, and it becomes clear that the pump valve is the most critical component in the fluid end in terms of pump operability.

The pump designer will size the valves to provide a flow area, called the *spill area*, that prevents pre-established velocity limits from being exceeded. The spill area of various valve types is given in Table 10. The velocity of the fluid flowing through the spill area is called the spill velocity,  $V$ , shown in Table 11:

**TABLE 10** Types of valves and their applications (Flowserve Corporation)

TYPE	SKETCH A = SEAT AREA B = SPILL AREA	PRESSURE, PSI (BAR)	APPLICATION
PLATE		5,000 (345)	CLEAN FLUID. PLATE IS METAL OR PLASTIC
WING		10,000 (690)	CLEAN FLUIDS. CHEMICALS
BALL		30,000 (2,069)	FLUIDS WITH PARTICLES. CLEAR, CLEAN FLUID AT HIGH PRESSURE. BALL IS CHROME PLATED
PLUG		6,000 (414)	CHEMICALS
SLURRY		2,500 (172)	MUD, SLURRY. POT DIMENSIONS TO API-12. POLYURETHANE OR BUNA-N INSERT

**TABLE 11** Valve spill velocities

Valve	Spill velocity, ft/s (m/s)
Clean liquid suction valve	3-8 (0.9-2.4)
Clean liquid discharge valve	6-20 (1.8-6)
Slurry suction and discharge valve	6-12 (1.8-3.7)

In USCS units  $V$  (ft/sec) = gpm through the valve  $\times 0.642$ /spill area of the valve, in<sup>2</sup>

In SI units  $V$  (m/s) = m<sup>3</sup>/h through valve  $\times 555.6$ /spill area of the valve, mm<sup>2</sup>

The quantity 0.642 (555.6) is used because all the liquid passes through the valve in half the stroke.

**Valve Dynamics** Valve dynamics is the mechanical response of the valve to the changes of pressure across the valve. Using a suction valve as an example, the valve starts its cycle when the valve is closed and the plunger is at the start of its suction stroke (maximum insertion into the cylinder). As the plunger starts withdrawing from the cylinder, the internal volume in the cylinder starts to increase. This increasing volume results in decreasing cylinder pressure that, in turn, hydraulically unbalances the valve and the valve begins to open. There is usually a slight lag in the valve opening versus the start of the plunger motion of about 5 to 20 degrees of crankshaft rotation. Traditionally, the opening valve lag is attributed solely to the inertia required to set the valve in motion and the preload of the valve spring. In the last few years, the theory of *valve stiction* has been proposed as an additional cause of valve opening lag.

Valve stiction, as the name implies, can be an additional force to overcome when the valve is trying to lift off its seat. One version of the theory is that a cohesive force exists between the fluid molecules and the sealing surfaces of the valve and seat. This can be demonstrated by trying to separate two wet, highly machined plates. The second stiction theory focuses on possible fluid dynamic conditions that may occur as fluid starts to flow across the valve seat. Valve seats do not have “knife edge” sealing surfaces; they have a width that distributes the stresses in the valve and seat. The stiction theory postulates that the flow of fluid from the smaller area at the center of the seat to the larger area around the seat causes a pressure drop across the seat. The pressure drop is the result of the radial divergence of the fluid and is strong enough to momentarily prevent the valve from opening. Extreme cases have even resulted in a circumferential ring of cavitation located at the center of the sealing areas of the seat and valve.

Field testing valves with special grooves and radial slots in the sealing face has proven successful in reducing stiction and opening valve lag in some cases. Narrowing the sealing faces may also prove effective, although part life may decrease due to increased stress and decreased wear area. Additional computer modeling and testing is required before the stiction theory can be completely validated.

As the valve continues to open, the spill area increases proportionally. It must be remembered that fluid is now flowing through the valve at an increasing rate while trying to fill the expanding cylinder volume created by the plunger withdrawal. Ideally, the motion of the valve will exactly correspond to the flow rate of the fluid through the valve, and the valve follows a smooth trajectory to a full open position (see Figure 9).

This idyllic situation only occurs in very slow running pumps that are fitted with oversized valves. In modern higher speed pumps, the valve often accelerates at a rate fast enough to create a spill area greater than that required to maintain a constant flow velocity. At this point, the valve motion momentarily stops, and the valve may even start to close before the fluid flow once again matches the spill area. The valve then returns to the smooth trajectory until the maximum valve lift occurs.

After the plunger passes the mid point of its stroke, it starts decelerating. The flow of fluid through the valve is high enough to start to build pressure in the cylinder and unbalance the valve and start the valve closing. The valve spring has reached its maximum compression and, if properly designed, will help accelerate the valve back toward the seat. When the plunger reaches the end of the suction stroke, the valve should also be closing. The amount of crankshaft rotation that occurs between the time when the plunger reaches the end of its stroke and when the valve is completely closed is called the *delayed valve closing* and is normally 2 to 12 degrees of crank rotation. Although a delayed valve opening may have little effect on overall pump performance, a delayed valve closing certainly will. A valve that is partially open when the plunger reverses direction will result in backflow. Backflow, as the name implies, is the reverse flow of fluid back across the valve and results in lower pump volumetric efficiency.

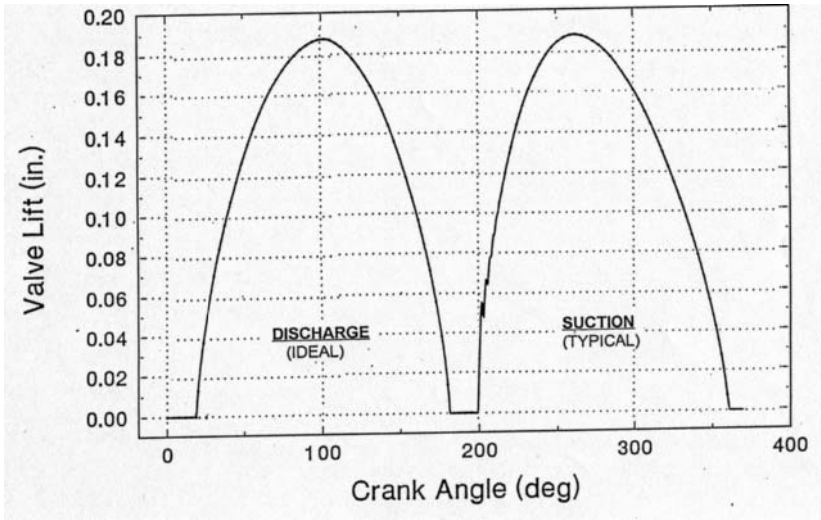


FIGURE 9 Valve lift versus crank angle (in  $\times 2.54 =$  cm)

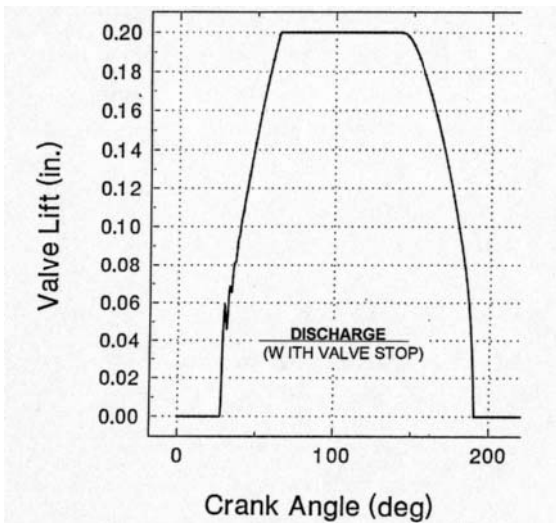


FIGURE 10 Valve lift versus crank angle for a valve with a mechanical stop (in  $\times 2.54 =$  cm)

Many pump valves are designed with mechanical limits to the distance that the valve is allowed to open or lift. This is normally done to avoid overstressing the valve spring and to minimize the overall height of the valve assembly. Valve motion for a valve designed with a mechanical stop is shown in Figure 10. Another advantage of this design is that the valve does not have to travel as far during its closing cycle, compared to valves with no mechanical limits. The disadvantage is the potential for impact damage to the valve if it strikes the stop with excessive force.

The importance of valve mass to overall valve dynamics has been the subject of much debate among pump designers over the years. There is no question that the mass of the valve must be overcome in order to open the valve. Test data is also available that shows no appreciable difference in the performance of pumps fitted with hollow ball valves versus identical pumps with solid ball valves. This apparent contradiction can be explained by studying valve acceleration at various parts of the valve cycle using advanced computer modeling.

It has already been explained above why a valve can hesitate, or stop opening, during the opening portion of its cycle. It's also been stated that when the valve spill area is large enough to establish a hydraulic balance, the valve will stop opening. What actually occurs is the valve starts decelerating as it comes closer to hydraulic equilibrium. If the valve is properly designed, it will contact its mechanical stop just as its acceleration/deceleration is very low. In that case, the valve mass has little significance on the impact force of the valve on the stop. The same holds true of the impact force of the valve on the seat as it closes. If the valve is properly designed, a 62-lb (28 kg) solid ball valve operating at 100 cycles per minute can strike the seat with less than 20 lbs (9 kg) of force.

Although pump valves operate in a liquid medium, the shape of the valve is not an important design consideration for most applications. The relatively small distance that a valve travels is not sufficient for the fluid dynamics of a shape to have a measurable effect on valve dynamics. The only exception to this is valves in pumps handling high-viscosity liquids. For these applications, the ball valve, often spring-loaded, has proven to reduce closing valve lag and increase volumetric efficiency better than any other type of valve.

The most critical component in the optimization of valve dynamics is the valve spring. The pump designer normally selects a valve spring that will exert a certain amount of "pre-load" on the valve when it is closed. This pre-load helps the valve to close smoothly on the seat and avoid rebound (and possible backflow). Too high a preload in the suction valve may result in higher net positive suction head required (NPSHR). In the discharge valve, excessive preload can cause abnormally high pressure spikes in the fluid cylinder just before the valve opens.

The other valve spring design criterion is the spring rate. Every compression spring develops a predetermined resistance per unit length. This value is expressed in pounds per inch (kg per cm). As the valve is opening, the increasing spring force helps the valve obtain hydraulic balance faster. It also helps to limit the impact force of the valve on the stop. At the start of the closing cycle, the stored energy in the compressed spring helps the valve respond faster to the pressure changes in the fluid cylinder as the plunger starts to decelerate. Again, if the spring is properly designed, the closing valve lag will be minimized.

No published guidelines exist for the proper amount of valve spring pre-load or spring rate. Most pump designers use proprietary values, generated through a combination of in-house and field testing. However, although these values produce low NPSHR and high volumetric efficiency in most cases, the valve dynamics may not be close to being optimized. It should also come as no surprise that pumps fitted with "off-the-shelf" commercially available valves do not operate as well as pumps having optimized valve dynamics.

With the recent advent of advanced computer modeling of pump valves, it is now possible to optimize valve dynamics for a specific set of pump operating parameters. We may also see valve designs in the near future having variable rate valve springs, hydraulic dampening, and mechanisms that induce rotation as the valve opens and closes.

## **POWER END THEORY**

---

The power end or drive end of a power pump consists of a crankshaft, connecting rods, crossheads, and bearings, all housed in a rigid structure referred to as the frame. Details of the design and construction of these components are covered in Section 3.2, "Power Pump Design and Construction." The slider-crank mechanism that converts rotational driving energy to the reciprocating motion that actuates the pistons or plungers can be found in reciprocating gas compressors, automotive engines, and stationary and marine engines. However, the stress loading pattern of power pump components is unique to this type of mechanism.

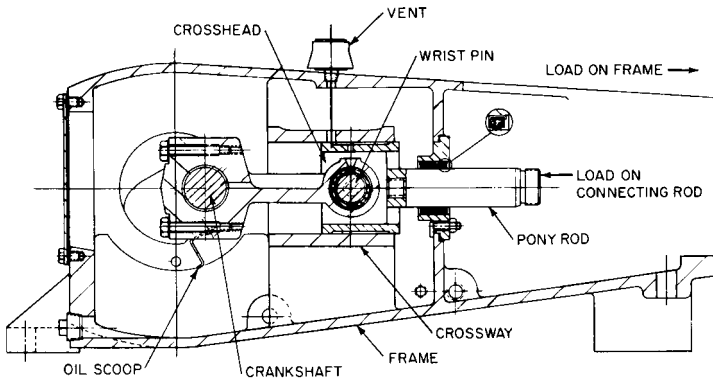


FIGURE 11 Power end, horizontal pump (Flowserve Corporation)

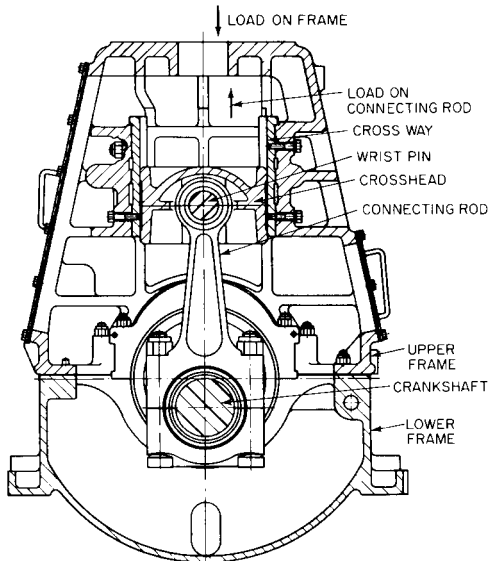


FIGURE 12 Power end, vertical pump (Flowserve Corporation)

**Applying Rod Load to the Power End** As stated earlier, the loading on the power end is called the rod load and is the product of the area of the plunger multiplied by the maximum discharge pressure. In a gas compressor or engine, this loading increases over 90 to 180 degrees of crank rotation before maximum loading is reached. In a power pump, the maximum loading is reached in less than 30 degrees of crank rotation due to the relative incompressibility of the pumpage. Since this loading cycle is repeated with each plunger stroke, the actual loading resembles a shock load more than a simple cyclic fatigue load. The design criteria for the stressed components of the power end must therefore include the material's capability to absorb shock loads and overall safety factors greater than 3:1.

Another critical factor in the capability of the power-end components to handle the rod load is how the load is applied. Figures 11 and 12 show the direction of the load on the

frame and connecting rod for two different power end configurations. On vertical pumps with outboard packed stuffing boxes, the frame is in compression and the crosshead and connection rod are in tension. With horizontal, single-acting pumps, the frame is in tension, and the crosshead and connecting rod are in compression. The material selection and factors of safety must be altered accordingly.

**Liquid Separation from the Plunger** It has already been explained that fluid flows through the suction valve (and suction manifold and related piping) to fill the increasing cylinder volume caused by the withdrawal of the plunger. If the plunger accelerates faster than the flow of incoming liquid, the liquid will lose contact or separate from the plunger. The void that forms will be at a pressure lower than anywhere else in the cylinder. If the pumpage contains entrained gas, the gas may come out of a solution in this low-pressure area. The gas bubbles, when recompressed later in the plunger stroke, can cause cavitation damage to the plunger and surrounding cylinder.

The geometry of the slider-crank mechanism affects the point at which liquid separation occurs. As the ratio of the connecting rod length to the crank radius increases, the pump speed at which liquid separation occurs will decrease. Since liquid separation can be the determining factor in a pump's NPSHR, the pump designer must carefully evaluate the slider-crank geometry in order to optimize the pump's hydraulic performance. The pump speed at which water will separate from the end of the plunger can be calculated from the following:

$$\text{In USCS units:} \quad \text{rpm} = 54.5 \sqrt{\frac{(34 - h_s - h_f)A_s}{LR[l - (l/LR)]A_p}}$$

$$\text{In SI units:} \quad \text{rpm} = 16.6 \sqrt{\frac{(10.36 - h_s - h_f)A_s}{LR[l - (l/LR)]A_p}}$$

where  $h_s$  = suction head, ft (m)

$h_f$  = piping frictional loss, ft (m)

$A_s$  = area of suction pipe, in<sup>2</sup> (mm<sup>2</sup>)

$L$  = length of connecting rod, centerline to centerline, ft (m)

$R$  = crank radius, ft (m)

$l$  = length of pipe where resistance to flow is to be measured, ft (m)

$A_p$  = area of plunger, in<sup>2</sup> (mm<sup>2</sup>)

**Unbalanced Forces** Due to the relatively slow speed of a power pump, the inertia loads of the rotating/reciprocating parts are low enough to avoid the vibration problems associated with centrifugal pumps. For that reason, power pump crankshafts are not normally balanced. However, when the power pump is coupled to a drive containing a high-speed motor and gear reducer, a torsional analysis of the pump/drive unit may be required. For this analysis, the unbalanced forces of the rotating and reciprocating pump components can be calculated as follows:

**Unbalanced Reciprocating Parts Force ( $F_{rec}$ )** Parts are typically about one-third of the connecting rod weight (the crosshead, the crosshead bearing, the wrist pin, the pony rod, and the plunger). Additional parts on vertical pumps include the pull rods, yoke, and plunger nut.

$$F_{rec} = \frac{W}{g} \omega^2 R \left( \cos \theta + \frac{R}{L} \cos \theta \right)$$

where  $F_{rec}$  = reciprocating parts force, lb (N)

$W$  = weight of all reciprocating or rotating parts, lb (N)



$$g = 32.2 \text{ ft/s}^2 \text{ (9.81 m/s}^2\text{)}$$

$$\omega = (2\pi/60) \times n \text{ (n = pump rpm)}$$

$$R = \text{one-half of stroke, ft (m)}$$

$$L = \text{length of connecting rod, centerline to centerline, ft (m)}$$

$$\theta = \text{crank angle; usually maximum force is at } \theta = 0^\circ, \cos \theta = 1$$

**Unbalanced Rotating Parts Force ( $F_{rot}$ )** Parts are typically about two-thirds of the connecting rod weight, crank end bearing, and crankpin, where the variables are as above.

$$F_{rot} = \frac{W}{g} \omega^2 R$$

**Mechanical Efficiency** The mechanical efficiency of a single-acting power pump without internal gears is typically 90 to 92%. Over half of the mechanical losses are due to the frictional drag of the plungers through the packing. The remaining losses are from the bearings, the crosshead-to-crosshead guide friction, and the extension rod-to-gland seal friction. If these components are properly lubricated, very few power-end design options are available that will produce a measurable increase in mechanical efficiency. Decreasing the diameter of the plungers and minimizing the number of packing rings will result in a small efficiency increase.

#### FURTHER READING

---

American National Standard for Reciprocating Power Pumps for Nomenclature, Definitions, Application and Operation, ANSI/HI 6.1-6.5-2000, Hydraulic Institute, Parsippany, NJ [www.pumps.org](http://www.pumps.org)

Positive Displacement Pumps—Reciprocating, API Standard 674. 2nd Edition, 1994, The American Petroleum Institute, Washington, D.C. [www.api.org](http://www.api.org)

Henshaw, T. L. *Reciprocating Pumps*. Van Norstrand Reinhold Company, Inc., New York, 1987.

Miller, J. E. *The Reciprocating Pump—Theory, Design and Use*. John Wiley & Sons, Inc., New York, 1987.

---

# SECTION 3.2

---

# POWER PUMP DESIGN AND CONSTRUCTION

---

WILLIAM K. CHAPLIS  
FREDERIC W. BUSE

The power pump, as a piece of rotating equipment, would seem to have a great deal in common with a reciprocating gas compressor or diesel or gas engine. All have crankshafts, bearings, connecting rods, and lubricating oil systems that use the pump frame as an oil reservoir. All have a fluid or gas end that contains relatively high pressure and includes some type of valving that enables the equipment to perform its required task.

Due to the unique operating characteristics of the power pump, very little design criteria or construction details can be directly transferred from these other mechanisms. Because of the high compressibility of most gases, the resulting cyclic loadings are applied to the various rotating, reciprocating, and pressure-retaining components in a smoother manner. Therefore, gas-driven or gas-pumping mechanisms can operate at speeds three or four times higher than a reciprocating pump with good reliability and low vibration levels.

It has been said that a power pump has more in common with a jackhammer because of the constant high-cycle shock loading that it must be designed to withstand. Therefore, very conservative material selections, stress limits, and factors of safety have been established by the pump designers for all continuous duty applications. Intermittent duty applications can be met using less stringent design criteria.

Seldom is a power pump designed for one specific application having one specific set of operating conditions. Consequently, few pump designs are truly optimized. The best economical approach has been to design a power end capable of accepting a number of fluid ends, which in turn allows the pump to operate over a wide range of hydraulic conditions. By using different plunger diameters for a specific operating pressure, the designer tries to "load up" the power to its maximum continuous rod load rating while maintaining the pump speed at a level just sufficient to provide the required flow rate.

A power pump has its cylinders operating in parallel with interconnecting suction and discharge manifolds. Additional cylinders are sometimes added to a basic power-end design in order to obtain higher flow rates. The most common examples of this approach are the quintuplex pumps that have an 80-percent component interchangeability with

triplex pumps. Triplex (three cylinder), quintuplex (five cylinder), septuplex (seven cylinder), and nonoplex (nine cylinder) pumps have been designed that have over a 90-percent interchangeability of parts. Only the power frame and crankshaft are unique to a specific pump size.

Factors of safety are used in power pump design and application. A connecting rod assembly, for instance, normally has a safety factor in excess of a 3:1 ratio because if a connecting rod fails in operation, it normally destroys many other power-end parts. A nodular iron frame will have a high safety factor also, primarily due to the requirement for thick wall sections to mount interfacing parts and to reduce operating noise levels. Some fluid-end expandable parts in the stuffing box and valves have safety factors below a 1.5:1 ratio because these parts are normally replaced before they would fail due to fatigue.

There has been a trend in past years in most industries to purchase power pumps that operate at higher and higher speeds. This has been driven by the economics of buying smaller, higher speed equipment versus the older, large, slower speed pumps. This trend seems to be losing some momentum, especially in critical applications. It remains for the pump purchaser and pump supplier to jointly evaluate each application and try to arrive at a pump selection that will provide the most reliable performance for the lowest installed cost and operating cost.

## LIQUID END

The liquid end consists of the cylinder, the plunger or piston, the valves, the stuffing box, the manifolds, and the access covers. Figure 1 shows the liquid end of a horizontal pump, and Figure 2 shows the same for a vertical pump.

**Cylinder (Working Barrel)** The cylinder is the body where the pump pressure to overcome discharge pressure is developed. It is continuously under fatigue. Cylinders on many horizontal pumps have suction and discharge manifolds integral with the cylinder. Vertical pumps have separate manifolds.

A cylinder containing the passages for more than one plunger is referred to as a *single cylinder*. When the cylinder is used for one plunger, it is called an *individual cylinder*. Individual cylinders are used where developed stresses or replacement costs are high.

Cast cylinders are usually limited to the developed pressures listed in Table 1. Forged cylinders are made from 1020 and 4140 carbon steel; 304L, 316L, 17-4 PH, and 15-5 PH stainless steels; and nickel aluminum bronze. In recent years, duplex stainless steels have seen an increase in usage when higher strength and corrosion resistance is required.

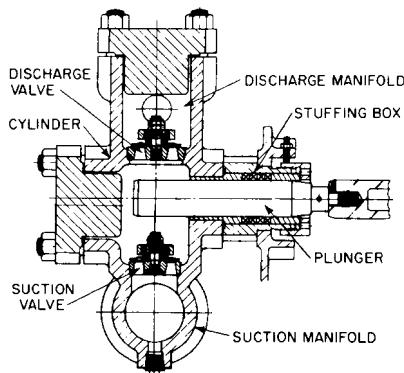


FIGURE 1 A liquid-end horizontal pump (Flowservice Corporation)

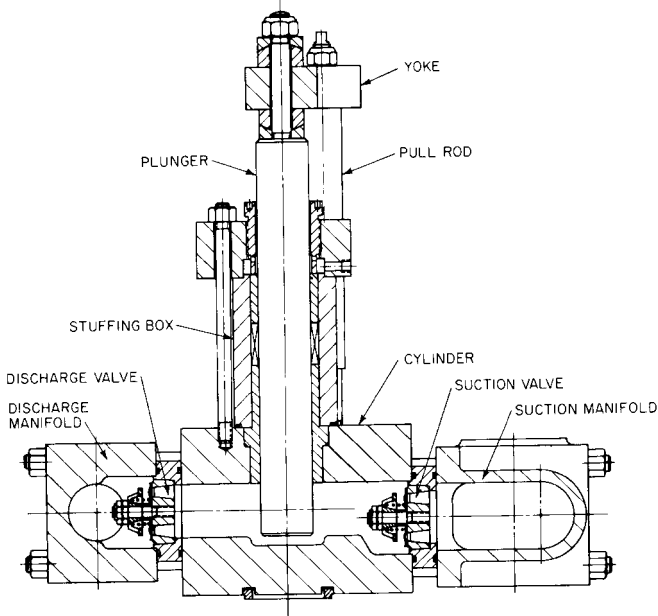


FIGURE 2 A liquid-end vertical pump (Flowserve Corporation)

TABLE 1 Maximum pressure in cast cylinders

Material	lb/in <sup>2</sup> (bar)
Cast iron	2000 (137)
Aluminum bronze	2500 to 3000 (172 to 207)
Steel	3000 (207)
Ductile iron	3000 (207)

Forged cylinders have a 4:1 to 6:1 forging reduction on all sides of the cylinder to obtain a homogeneous internal structure. This type of cylinder requires heat treatment after forging to eliminate the stresses that occur during the forming operation. The pump designer must minimize the section thickness of the cylinder or residual stresses may remain after machining the internal bores.

The highest stresses occur at the intersection of the horizontal and vertical internal bores. Unlike a simple cylinder where the internal stresses are analyzed as a single hoop stress, the stress at the intersecting bores of a power pump cylinder are based on a double hoop stress. In Figures 3 and 4, the distances  $b$  and  $d$  are the internal diameters,  $a$  and  $c$  are the diameters to the nearest obstruction of the solid material of the cylinder,  $P$  is the developed pressure, and  $S$  is the resulting stress. Stress concentration factors at the intersecting bores can be omitted if the radius is not less than 0.25 in (1.5 mm). Above 3000 lb/in<sup>2</sup> (207 bar), the internal bores should have a surface finish of 63 rms minimum.

During each plunger cycle, the developed pressure goes from suction pressure to discharge pressure and back to suction. For a pump operating at 360 strokes per minute, over six million fatigue cycles will occur in less than 12 days. For this reason, very conservative allowable stress limits are used. Normally, these limits range from 10,000 to 25,000 lb/in<sup>2</sup> (69 to 172 Mpa), depending on the material of the cylinder, duty cycle, and liquid being

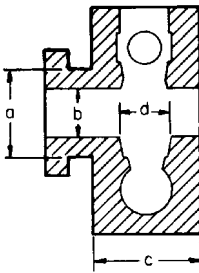
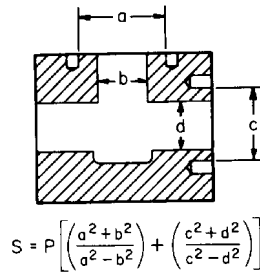


FIGURE 3 Stress dimensions for a horizontal liquid end (Flowsolve Corporation)



$$S = P \left[ \left( \frac{a^2 + b^2}{a^2 - b^2} \right) + \left( \frac{c^2 + d^2}{c^2 - d^2} \right) \right]$$

FIGURE 4 Stress dimensions for a vertical liquid end (Flowsolve Corporation)

pumped. The allowable stress is a function of the fatigue stress of the material for the liquid being pumped and the life cycles required.

Due to improper suction system design, misapplications, or process upsets, instantaneous pressure in the cylinder may be much higher than design pressure. When the liquid contains entrained gas that can be released because of inadequate suction pressure, the resulting cavitation can cause instantaneous pressure four to five times the design pressure. This results in reducing the life of the cylinder and other liquid-end components, as well as damaging pressure pulsations in the suction and discharge piping systems.

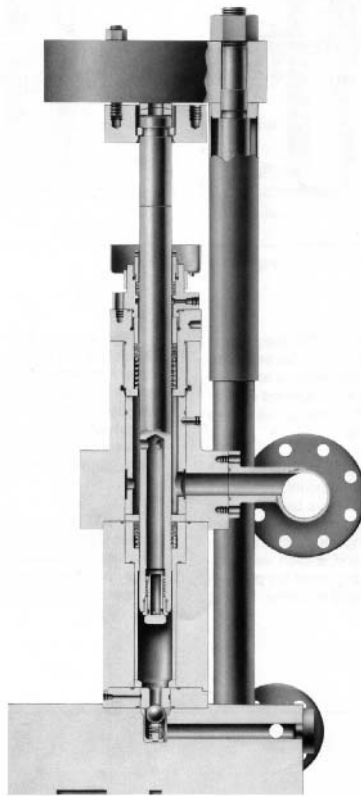
For continuous duty pumps operating above 10,000 lb/in<sup>2</sup> (690 bar) of discharge pressure, special liquid-end designs have been developed. In Figure 5, the intersecting bores have been eliminated by arranging the suction and discharge valves on the same axis as the plunger. This means the stresses in the cylinder will be only half of those in a comparable T-block design.

**Plungers** The plunger transmits the force that develops the pressure. It is normally a solid construction of up to 5 in (127 mm) in diameter. Above that dimension, it may be made hollow to reduce its weight. Small-diameter plungers used for 6000 psi (414 bar) and above should be reviewed for possible buckling. Plunger speeds range from 150 to 350 fpm (46 to 107 m/s). The surface finish normally is between 14 and 20 rms. A finish below 8 rms should be avoided because excessive packing leakage may occur due to the inability of the packing to seal properly on the smooth surface.

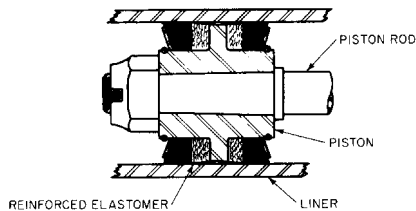
Although some plungers are made of heat-treated or case-hardened steel, the most common are the hard-coated or solid ceramic. The hard coatings are normally flame sprayed powders of Colmonoy or tungsten carbide, or ceramic oxides. These can be applied over base materials of 1020 carbon steel or 316L stainless steel. Ceramic oxide is normally limited to 200°F (93°C) and is used for soft water, crude oil, mild acids, and mild alkalis.

The porosity and bond strength of coatings must be carefully evaluated for use with higher operating pressures. Under those conditions, the liquid may penetrate the pores of the coating and lift the coating off the base material. Ceramic plungers also have special requirements and limitations. This type of plunger is often constructed as a solid bar, closed-end tube of ceramic, bonded to a metal end cap or plug. A vent must be provided to allow the pressure inside the plunger to equal the atmospheric pressure or the ceramic-to-metal bond may fail or the plunger may explode. In addition to the normally fragile nature of any ceramic plunger, the solid ceramic plunger is susceptible to failure due to thermal shock.

**Pistons** Pistons are used for water pressures up to 2000 lb/in<sup>2</sup> (138 bar). For higher pressures, a plunger is usually used. Pistons are cast iron, bronze, or steel with reinforced elastomer sealing rings (see Figure 6). They are most frequently used in duplex, double-acting pumps. The latest trend is to use pistons in single-acting triplex pumps.



**FIGURE 5** Special high-pressure liquid-end designs arrange the suction and discharge valves on the same axis as the plunger, thus eliminating intersecting bores (Flowserve Corporation).



**FIGURE 6** Elastomer face piston (FWI)

**Stuffing Box** The stuffing box assembly consists of a stuffing box, upper and lower bushings, packing, and a gland. For ease of maintenance, the stuffing box assembly is usually removable (see Figure 7).

The stuffing box bore is machined to a 63 rms finish to ensure packing sealing and life. A single hoop stress equation is used to determine the wall thickness with an allowable stress limit of 10,000 to 20,000 lb/in<sup>2</sup> (69 to 138 MPa).

The bushings that guide the plunger have a 63 rms finish with approximately 0.001 to 0.002 in (0.02 to 0.05 mm) of diametrical clearance per inch of the plunger diameter. The

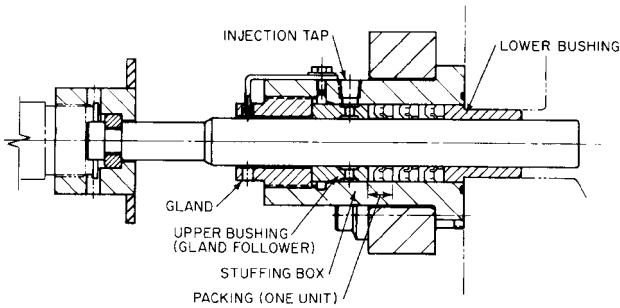


FIGURE 7 A stuffing box (Flowserve Corporation)

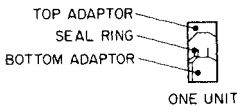


FIGURE 8 Chevron packing (Flowserve Corporation)

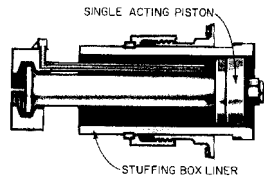


FIGURE 9 Single-acting piston stuffing box (Flowserve Corporation)

lower bushing is sometimes secured in an axial position to prevent movement of the packing. Bushings are made of bearing bronze, Ni-resist, or cast iron. Stainless steel can be used if its antigalling properties with the plunger coating can be verified.

Packing is either square cross-section, woven construction or molded V or chevron-shaped (see Figure 8). Some types use metal backup adapters. A packing set consists of top and bottom adapters and one or more packing sealing rings. A stuffing box can use two to five rings of packing, depending on the pressure and the fluid being pumped. Packing rings are usually made up of a number of composite materials selected for their strength, wear resistance, and lubricity, including neoprene, Teflon, cotton duct, and Kevlar.

Packing can be made self-adjusting by installing a spring between the bottom of the packing set and the lower bushing or bottom of the stuffing box. This arrangement eliminates overtightening the packing and enables a more uniform break-in. Packing can be lubricated through a grease fitting or by an auxiliary lubricator driven through a take-off on the crankshaft.

For chemical or slurry service, a lower injection ring is used for flushing. This prevents concentrated pumped fluid from impinging directly on the packing. This injection can be continuous or synchronized to inject only on the suction stroke. Flush glands at the outboard end of the stuffing box are employed when a toxic vapor is present or when the leakage may flash.

The stuffing box for the piston rod of a double-acting pump is similar in construction to that of a stuffing box for a plunger. The primary difference is that it must seal against pressure being developed while the rod moves back through the packing. Single-acting pistons do not employ a stuffing box. Leakage past the piston-sealing rings goes into the frame extension to mix with the continuously circulating lubricant.

**Cylinder Liner** The cylinder wear liner (refer to Figure 6 and see Figure 9) is usually of Ni-resist material. Its length is slightly longer than the stroke of the pump to enable an assembly entrance taper of the piston into the liner. In double-acting pumps, the liner has packing to prevent leakage from the high-pressure side to the low pressure side of the

cylinder. Because of the brittleness of the liner, the construction should be such that the liner is not compressed. The finish of the bore of the liner is approximately 16 rms.

**Valves** Many types of valve designs exist. Which type is used depends on the application. The main parts of a valve assembly are the seat and sealing member, usually a disc, ball, or plate. The plate movement is controlled by a spring or retainer. The seat usually uses a taper where it fits into the cylinder or manifold. The taper not only gives a positive fit but permits easy replacement of the seat.

Some pumps use the same size suction and discharge valve for interchangeability (refer to Figure 2). Some use larger suction valves than discharge valves for improved NPSH reasons. Others use larger discharge valves than suction valves because the cylinder configuration requires the suction valve to be removed through the location of the discharge valve (refer to Figure 1). Because of space considerations, valves are sometimes used in clusters on each side of the plunger to obtain the required total valve area that reduces valve velocity.

Table 2 shows seat and plate hardness for some valve materials. Seats and plates made of 316 stainless steel material are usually chrome-plated or flame-sprayed to give them the desired surface hardness.

The flow area of the valve must be large enough to prevent significant pressure drop or restriction to flow. Normally, suction valves are sized for 6 to 8 ft/s velocity, and the discharge valves are sized for 8 to 12 ft/s.

The valve springs must be made of corrosion-resistant material and designed to withstand high-cycle fatigue stresses. Under no situation should the valve operation enable the spring to go to a solid stack height or wire-to-wire condition. The ends of the spring must be ground flat and square with a maximum perpendicularity of 3 degrees.

**Manifolds** These are the chambers where the liquid is disbursed or collected for distribution before or after passing through the cylinder. In horizontal pumps and some vertical pumps, the manifolds are cast or machined integral with the fluid cylinder. Most vertical pumps have the suction and discharge manifolds separate from the cylinder (refer to Figure 2).

Suction manifolds are designed to eliminate air pockets from the flange to the valve entrance (see Figure 10). Separate suction manifolds are cast iron, cast bronze, or fabricated steel. Discharge manifolds are steel forgings or fabricated steel. The manifolds have a minimum deflection to prevent gasket shifts when subjected to maximum operating pressures.

The velocity through the manifolds of a clean liquid is 3 to 5 ft/s (0.9 to 1.5 m/s) at the suction and 6 to 16 ft/s (1.8 to 4.9 m/s) at the discharge. Suction and discharge manifold velocities in a slurry service are 6 to 10 ft/s (1.8 to 3 m/s). Slurry services have a minimum velocity of 6 ft/s (1.8 m/s) to prevent the heavier slurry particles from falling out of solution.

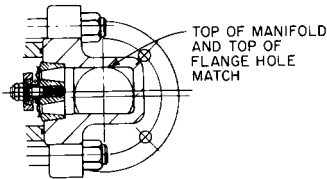
In USCS units,  $V$  (ft/s) = pump gpm  $\times$  0.321/cross-sectional area of the manifold, in<sup>2</sup>

In SI units,  $V$  (m/s) = pump m<sup>3</sup>/h  $\times$  277.8/cross-sectional area of the manifold, mm<sup>2</sup>

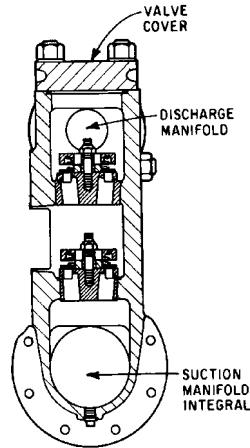
**TABLE 2** Recommended material hardness for valve plate and seat

Material	Plate	Seat
Rockwell C hardness		
329	30 to 35	38 to 43
440	44 to 48	52 to 56
17-4 PH	35 to 40	40 to 45
15-5 PH	35 to 40	40 to 45
Brinell hardness		
316	150 to 180	150 to 180





**FIGURE 10** A suction manifold construction to eliminate air pockets (Flowserve Corporation)



**FIGURE 11** An integral suction and discharge manifold (Gardner-Denver)

A water hammer creates an additional pressure (which is added to the rated pump pressure), as does hydraulic shock loading. The discharge manifold rating is then made equal to or greater than the sum of these pressures.

**Valve Covers** Valve covers are used to provide accessibility to the valves without disturbing the cylinder, manifold, or related piping (see Figures 11 and 12).

**Plunger Covers and/or Cylinder Heads** These are used on horizontal pumps to provide accessibility to the plunger, piston, and cylinder liner (refer to Figures 11 and 12 and see Figure 13).

## POWER END

---

The power end contains the crankshaft, connecting rods, crossheads, pony rod, bearings, and frame (see Figures 14 and 15). Basic designs are horizontal and vertical with sleeve or antifriction bearings. Some have integral drive gears.

**Frame** The frame absorbs the plunger load and torque. Vertical pumps with outboard packed stuffing boxes (refer to Figure 2) have the frame in compression (refer to Figure 14). With horizontal single-acting pumps, the frame is in tension (refer to Figure 15). Frames are usually close-grain cast iron with relatively thick cross-sections. This combination provides superior dampening for the normal low-frequency cyclic loading. Some intermittent duty pumps, specifically designed for mobile services, are constructed of lighter weight, fabricated steel plate.

The frame is usually vented to the atmosphere. However, when the atmosphere is detrimental to the working parts of the frame, such as an ammonia attack on bronze bearings, the frame can be purged continuously with nitrogen gas.

**Crankshaft** The crankshaft (see Figures 16, 17, and 18) varies in construction, depending on the design and power output of the pump. In horizontal pumps, the crankshafts are usually of nodular iron or cast steel. Vertical pumps use forged steel or machined billet crankshafts. Because the crankshafts have a low mass and operate at relatively low

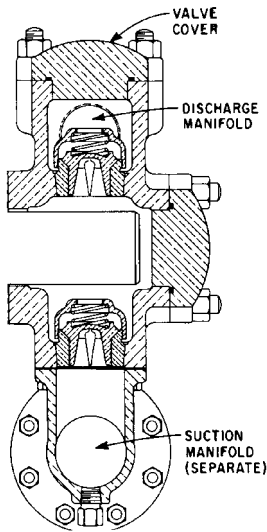


FIGURE 12 Separate suction with an integral discharge manifold (Gardner-Denver)

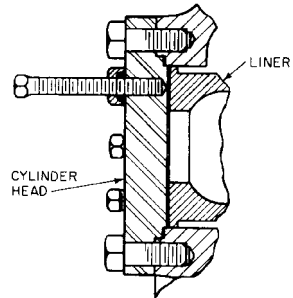


FIGURE 13 A plunger cover (FWI)

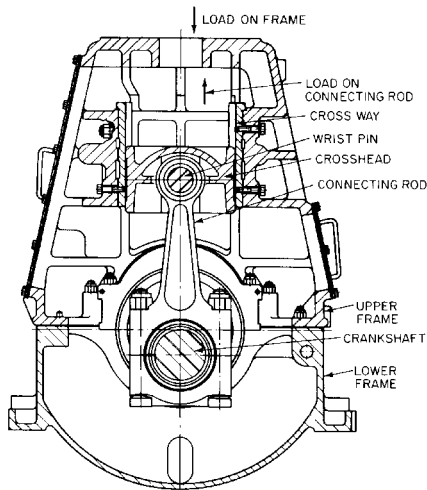


FIGURE 14 A vertical pump power end (Flowserve Corporation)

speeds, counterweights and flywheels are not used. Except for duplex pumps, the crankshaft always has an odd number of throws to obtain the best flow pulsation characteristics. The firing order in a revolution depends on the number of throws on the crankshaft (see Table 3).

The crankshaft main and rod-bearing surfaces are ground to a 16 rms surface finish or better. Large radii are used where journal diameters intersect with the adjacent cheeks to

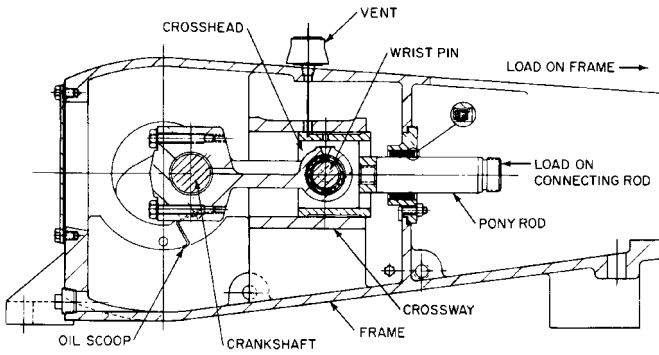


FIGURE 15 A horizontal pump power end (Flowserve Corporation)

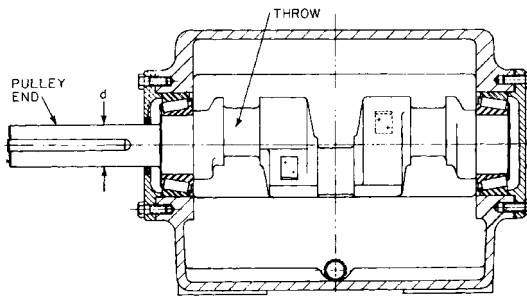


FIGURE 16 A cast crankshaft (Flowserve Corporation)

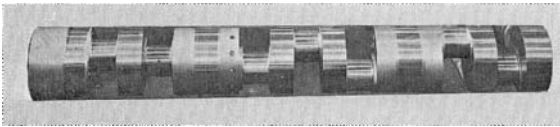


FIGURE 17 A crankshaft machined from a billet (Flowserve Corporation)

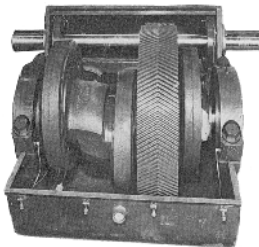
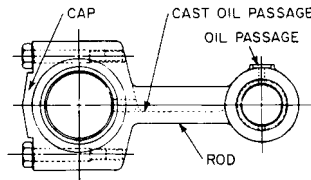


FIGURE 18 A cast crankshaft with integral gear (Continental-EMSCO)

**TABLE 3** Order of Pressure Build-up or Firing Order

Throw from pulley end	No. of plungers or pistons	Pressure build-up order								
		1	2	3	4	5	6	7	8	9
Duplex	2	1	2							
Triplex	3	1	3	2						
Quintaplex	5	1	3	5	2	4				
Septuplex	7	1	4	7	3	6	2	5		
Nonuplex	9	1	5	9	4	8	3	7	2	6

**FIGURE 19** The connecting rod (Flowsolve Corporation)

minimize stress concentrations in these fatigue-prone areas. Cross-drilling of the main to rod journals is often provided to furnish lubrication to the crankpin bearings.

Many horizontal pumps under 250 hp (186 kW) are driven by means of a sheave or pulley and belt arrangement. Increasing the diameter of the pulley for a given horsepower will increase the stress in the crankshaft. The maximum allowable crankshaft stress will often limit the maximum diameter of the pulley that can be used. Stress levels of 2000 to 3000 lb/in<sup>2</sup> (14 to 20.7 MPa) are common, where  $d$  is the pulley end diameter of the crankshaft in inches (mm) and  $n$  is the pump speed in revolutions per minute.

**Connecting Rods and Eccentric Straps** The connecting rods (see Figure 19) transfer the rotating force of the crank pin to an oscillating force on the wrist pin. Most connecting rods are split perpendicular to their centerline at the crankpin end for ease of assembly onto the crankshaft.

The cap and rod are aligned with close-tolerance bushings or body-bound bolts. The rods either are rifle-drilled or have cast passages to transfer oil from the wrist pin to the crank pin. A connecting rod with a tension load is made of forged steel, cast steel, or fabricated steel. Rods with a compressive loading are cast steel, nodular iron, or aluminum alloy. The connecting rod finish, where the bearings are mounted, is 32 to 63 rms.

The ratio of the distance between the centerlines of the wrist pin and crank pin bearings to half the length of the stroke is referred to as the  $L/R$ . The ratio directly affects the pressure pulsations, volumetric efficiency, size of the pulsation dampener, speed of liquid separation, acceleration head, moments of inertia forces, and size of the frame. Low  $L/R$  results in higher fluid pulsations. A high  $L/R$  reduces pulsations but may result in a large and uneconomical power frame. The common industrial  $L/R$  range is 4:1 to 6:1.

The eccentric strap (see Figure 20) performs the same function as a connecting rod, except that the former usually is not split. The eccentric strap is furnished with rolling element bearings, whereas connecting rods are furnished with sleeve bearings. Eccentric straps are applied to mud pumps and some slurry pumps, which are started against a full load without requiring a bypass line.

**Wrist Pin** Located in the crosshead, the wrist pin transforms the oscillating motion of the connecting rod to a reciprocating motion. The maximum stress in the wrist pin from deflection should not exceed 10,000 lb/in<sup>2</sup> (69 MPa):

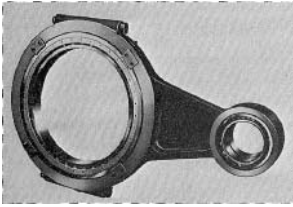


FIGURE 20 An eccentric strap (Gardner-Denver)

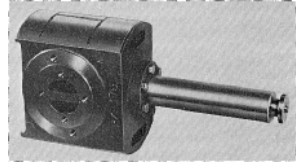


FIGURE 21 A crosshead (Gardner-Denver)

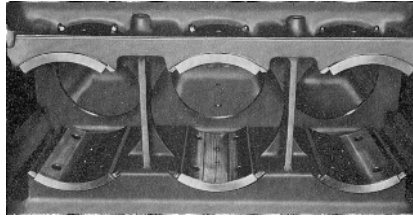


FIGURE 22 Crossways (Gardner-Denver)

In USCS units,

$$S = \frac{PL \times \ell}{8 \times 0.098d^3}$$

In SI units,

$$S = 1.25 \frac{PL \times \ell}{d^3}$$

where  $PL$  = plunger load, lb (N)

$\ell$  = length under load, in (mm)

$d$  = diameter of pin, in (mm)

Large pins are hollow to reduce the oscillating mass and assembly weight. Depending on the design, pins can have a straight fit, taper fit, or loose fit in the crosshead. The pin is case-hardened and has a surface finish of 16 rms or better. When needle or roller bearings are used for the wrist pin bearing, the pin serves as the inner race.

**Crosshead** The crosshead (see Figure 21) moves in a reciprocating motion and transfers the plunger load to the wrist pin. The crosshead is designed to absorb the side or radial load from the plunger as the crosshead moves linearly on the crossway. The side load is approximately 25% of the plunger load. For cast-iron crossheads, the allowable bearing load is 80 to 125 lb/in<sup>2</sup> (551 to 862 kPa). Crossheads are grooved for oil lubrication and have a 63 rms surface finish. Crossheads are piston types (full round) or partial-contact types. The piston type should be open or vented to prevent air compression at the end of the stroke.

In vertical pumps, the pull rods, or side rods, go through the crosshead so that the crosshead is under compression when the plunger load is applied (refer to Figure 14).

**Crosshead Guides (Crossways)** The crossway (see Figure 22) is the surface on which the crosshead reciprocates. In horizontal pumps, it is cast integral with the frame (refer to Figure 15). In large frames, it is usually replaceable and is shimmed to effect proper running clearances (refer to Figures 14 and 22). The crossway finish is 63 rms.

**Pony Rod (Intermediate Rod or Extension Rod)** The pony rod is an extension of the crosshead on horizontal pumps (refer to Figures 21 and 22). It is screwed or bolted to the

crosshead and extends through the frame (refer to Figure 15). A seal on the frame and against the pony rod prevents oil from leaking out of the frame. A baffle is attached to the plunger end of the pony rod to prevent stuffing box leakage from entering the frame.

**Pull Rod (Side Rod)** In vertical pumps, two pull rods are connected to the crosshead. The rods are secured by a shoulder and nut so that the cast iron is in compression when the plunger load (rod load) is applied. The rods extend out through the top of the frame and fasten to a yoke (upper crosshead). The plunger is attached to the middle of the yoke with an aligning feature for the plunger (refer to Figure 2). The nuts fastening the pull rod to the yoke and crosshead must be torqued to a high enough level to prevent the bolted joint from seeing cyclic loading.

**Bearings** Both sleeve and rolling element bearings are used in power pumps. Some power ends use all sleeve, others use all rolling element, and others use a combination of both.

### SLEEVE BEARINGS

---

When properly installed and lubricated, sleeve bearings are considered to have an infinite life. They are inexpensive and can usually be replaced without special tools and with minimum pump disassembly. The sleeve bearing is designed to operate within a certain speed range, and too high or too low a speed will upset the oil film lubrication. With standard sleeve-bearing designs, pumps cannot be operated at speeds below 20 rpm with the plunger fully loaded using standard lubrication. Below this speed, the oil film in the wrist pin bearing starts to break down and the increased friction causes excessive heat and leads to bearing failures. Recent developments of improved bearing materials, along with special grooving and other aids to lubrication, now allow for fully loaded pump operations at speeds as low as 10 rpm. The finish on the sleeve bearing is 16 rms. Clearances are approximately 0.001 in per in (0.001 mm per mm) of the diameter of the bearing.

**Wrist Pin Bearings** These bearings are normally the highest loaded bearings in the pump. They can only perform an oscillating motion and therefore cannot develop the dynamic oil film common to fully rotational bearings. In single-acting pumps with low suction pressure, adequate reversals in loading take place on the bearing to permit replenishment of the oil film. High suction pressure in a horizontal pump increases the reverse loading. In vertical pumps, high suction pressure can produce a condition of no reverse loading, and in this case, special bearing materials, grooving, and pump derating may be required. Increasing oil pressure by itself will not solve this problem. Allowable projected area loading is 1200 to 1500 lb/in<sup>2</sup> (8.27 to 10.3 MPa) with bearing bronze.

**Crank Pin Bearings** The crank pin bearing is a rotating split bearing and develops a better oil film than the wrist pin bearing. It is clamped between the connecting rod and cap. The bearing is a bronze-backed babbitt metal or a tri-metal automotive type bearing. The allowable projected area load is 1200 to 1600 lb/in<sup>2</sup> (8.27 to 11.08 MPa).

**Main Bearings** The main bearings absorb the plunger load and gear load. The total plunger load varies during each revolution of the crankshaft. The triplex main bearings receive the greatest variations in loading because the crankshaft has the greatest relative span between bearings. Sleeve bearings are flanged to locate them in an axial position, and the flange absorbs residual axial thrust. In long-stroke vertical pumps, a main bearing can be found between every connecting rod. Split bearings are a bronze-backed babbitt metal with an allowable loaded area of 750 lb/in<sup>2</sup> (5.1 MPa).

## ROLLING ELEMENT BEARINGS

A pump with rolling element bearings can be started under a full plunger load without a bypass line. Rolling element bearings enable the pump to operate continuously at low speeds with full plunger loads. They are selected for 30,000 to 50,000 hours of  $L_{10h}$  life. Slurry pipeline applications may require 100,000 hours. Eccentric straps are used in place of connecting rods.

**Wrist Pin Bearings** These are needle or roller bearings. The outer race is a tight fit into the strap, and the wrist pin is used as the inner race. This reduces the size of the bearing and strap. The wrist pin is held in the crosshead with a taper or keeper plate (see Figure 23).

**Main Bearing** The main bearings used in conjunction with sleeve wrist pin bearings and sleeve crank pin bearings are usually tapered roller bearings, as is the case with a horizontal triplex plunger pump. The main bearings are usually mounted directly into the frame (see Figure 24).

The main bearings used with full rolling element bearing designs are self-aligning spherical roller bearings. These bearings compensate for axial and radial movements of the crankshaft and are usually mounted in bearing holders, which in turn are mounted on the frame (refer to Figure 23). This type of design is mostly used in mud pumps and in some slurry pumps.

## LUBRICATION

Non-detergent SAE 30 to 50 oil is used for bearing lubrication. In splash lubrication, the cheeks of the crankshaft or oil scoops (refer to Figure 15) throw oil by centrifugal force against the frame wall. This oil is then distributed by gravity to the crosshead, wrist pin, and crank pin. At low speeds, there is not enough centrifugal force for proper oil distribution, so a partial force feed is then employed to maintain proper lubrication. Force-feed lubrication requires 0.5 to 1 gpm (1.9 to 3.8 l/m) per bearing with an oil pressure of 28 to 40 lb/in<sup>2</sup> (1.7 to 2.8 bar).

## APPLICATIONS

Power pumps are used in a variety of applications where high-pressure and low-flow requirements exist. They are also widely used when a high-volumetric efficiency is

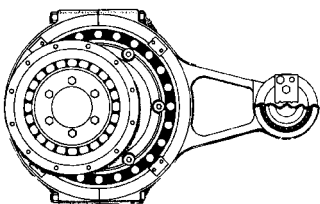


FIGURE 23 The main bearing mounted in a bearing holder (Gardner-Denver)

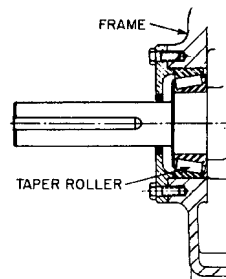


FIGURE 24 The main bearing mounted directly in the frame (Flowsolve Corporation)

required. For these applications, other types of pumps have design or operating deficiencies that make their lower initial cost or lower maintenance costs less attractive.

Some of the common applications for power pumps include the following:

Ammonia service	Liquid petroleum gas
Carbamate service	Liquid pipeline
Chemicals	Power oil
Crude-oil pipeline	Power press
Cryogenic service	Salt-water injection for water flood
Fertilizer plants	Slurry pipeline (up to 70 percent by weight)
High-pressure water cutting	Slush ash service
Hydro forming	Steel mill descaling
Hydrostatic testing	Water blast service

The following applications may require power pumps with special modifications, and the exact requirements should be reviewed in detail with the pump supplier:

Cryogenic service	Low-speed operation
Highly compressible liquids	Slurry pipeline
Liquids over 250°F (121°C)	Special fluid-end materials
Liquids with entrained gas	Viscosities over 500 SSU

**Duty Service** To make an economical pump selection, the type of full-load service that you need should be considered. For instance, a small, lighter weight pump operating at higher speeds may be suitable for an intermittent duty application such as hydrostatic testing. The different types of duty services are as follows:

- *Continuous*: 8 to 24 hours per day
- *Light*: 3 to 8 hours per day
- *Intermittent*: Up to 3 hours per day
- *Cyclic*: 30 seconds loaded out of every 3 minutes

## RELIEF VALVES

---

Relief valves should be rated for the full flow of the pump. The *set pressure* or *cracking pressure* must be sufficiently above the operating pressure to prevent normal pressure pulsations from activating the relief valve. The following values can be used as guidelines, but the final selection should be made only in agreement with the pump supplier and system designer:

- Duplex double-acting: 25 percent
- Triplex and above: 10 percent

**Bypass Relief** Starting a power pump under a full load requires a high starting torque. Also, a pump with sleeve-bearing construction when starting under a full load may not have adequate bearing lubrication to reach the operating speed.

The starting torque on the driver and plunger load on the bearings may be reduced by performing one of two steps:

- Install a bypass line from the discharge back to the source or to a drain (see Figure 25). This line is located between the pump discharge and a check valve before the discharge piping system. The bypass valve is operated manually or automatically. The bypass line



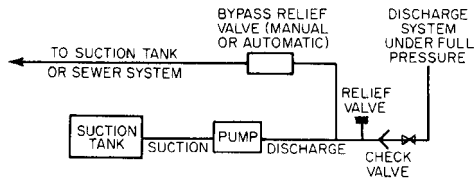


FIGURE 25 A bypass relief system (Flowserve Corporation)

reduces the starting torque from the mechanical losses and the liquid inertia of the suction and bypass systems. After the pump is up to speed, the bypass is closed and the pump goes into normal operation.

- Use suction valve unloaders. The unloader is a mechanism that mechanically holds the suction valves off of their seats before and during startup, which stops the pumping action. Only mechanical losses must be overcome. After the pump is up to speed, the suction valves are closed in unison. In large-flow pumps, an electronic distributor is used to synchronize actuation of the suction valves with the plunger pressure build-up order (or firing order).

### PULSATION DAMPENERS

The performance of a power pump, or its interaction with the suction and discharge piping systems, can often be improved by adding suction and discharge dampeners. Dampeners are used to reduce suction and discharge pressure pulsations. A properly sized and located suction dampener can reduce the system pulsations to an equivalent pipe length of 5 to 15 pipe diameters. If the dampener is the flow-through type, it should be located on the same side as the pipe, not at the dead end of the manifold.

The most commonly used dampeners are the gas-bladder types. These units are normally charged with nitrogen gas at 50 to 66 percent of the system pressure. Although these units are relatively inexpensive, they can attenuate up to 90 percent of the pressure pulsations, below 50 Hz, in the interconnecting piping systems.

---

# SECTION 3.3

---

# STEAM PUMPS

---

ROBERT M. FREEBOROUGH

## **BASIC THEORY**

---

A reciprocating positive displacement pump is one in which a plunger or piston displaces a given volume of fluid for each stroke. The basic principle of a reciprocating pump is that a solid will displace an equal volume of liquid. For example, when an ice cube is dropped into a glass of water, the volume of water that spills out of the glass is equal to the submerged volume of the ice cube.

In Figure 1, a cylindrical solid, a plunger, has displaced its volume from the large container to the small container. The volume of the displaced fluid (B) is equal to the plunger volume (A). The volume of the displaced fluid equals the product of the cross-sectional area of the plunger and the depth of submergence.

All reciprocating pumps have a fluid-handling portion, commonly called the *liquid end*, that has

1. A displacing solid called a *plunger* or *piston*
2. A container to hold the liquid, called the *liquid cylinder*
3. A suction check valve to admit fluid from the suction pipe into the liquid cylinder
4. A discharge check valve to admit flow from the liquid cylinder into the discharge pipe
5. Packing to seal the joint between the plunger and the liquid cylinder tightly to prevent liquid from leaking out of the cylinder and air from leaking into the cylinder

These basic components are identified on the rudimentary liquid cylinder illustrated in Figure 2. To pump the liquid through the liquid end, the plunger must be moved. When the plunger is moved out of the liquid cylinder as shown in Figure 2, the pressure of the fluid in the cylinder is reduced. When the pressure becomes less than that in the suction pipe, the suction check valve opens and liquid flows into the cylinder to fill the volume being

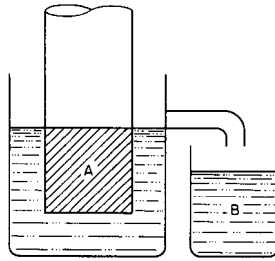


FIGURE 1 The volume of liquid displaced by a solid equals the volume of the solid

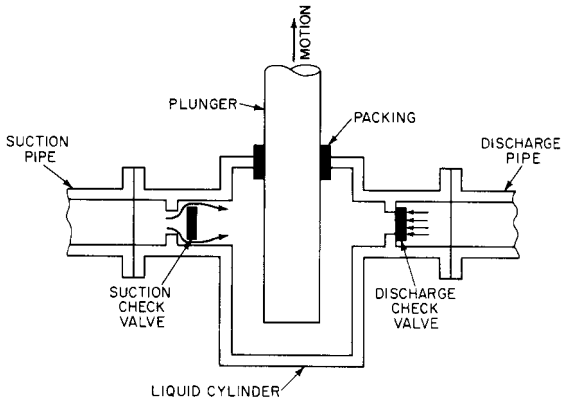


FIGURE 2 Schematic of the liquid end of reciprocating pump during the suction stroke

vacated by withdrawal of the plunger. During this phase of operation, the discharge check valve is held closed by the higher pressure in the discharged pipe. This portion of the pumping action of a reciprocating positive displacement pump is called the *suction stroke*.

The withdrawal movement must be stopped before the end of the plunger gets to the packing. The plunger movement is then reversed, and the *discharge stroke* portion of the pumping action is started, as illustrated in Figure 3.

Movement of the plunger into the cylinder causes an increase in pressure of the liquid contained therein. This pressure immediately becomes higher than suction pipe pressure and causes the suction valve to close. With further plunger movement, the liquid pressure continues to rise. When the liquid pressure in the cylinder reaches that in the discharge pipe, the discharge check valve is forced open and liquid flows into the discharge pipe. The volume forced into the discharge pipe is equal to the plunger displacement less very small losses. The plunger displacement is the product of its cross-sectional area and the length of stroke. The plunger must be stopped before it hits the bottom of the cylinder. The motion is then reversed, and the plunger again goes on suction stroke as previously described.

The pumping cycle just described is that of a *single-acting* reciprocating pump. It is called single-acting because it makes only one suction stroke and only one discharge stroke in one reciprocating cycle.

Many reciprocating pumps are *double-acting*; that is, they make two suction and two discharge strokes for one complete reciprocating cycle (Figure 4). Most double-acting pumps use as the displacing solid a piston that is sealed to a bore in the liquid cylinder or

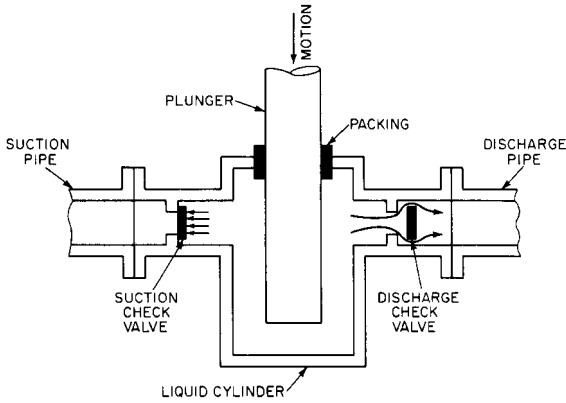


FIGURE 3 Schematic of the liquid end of a reciprocating pump during the discharge stroke

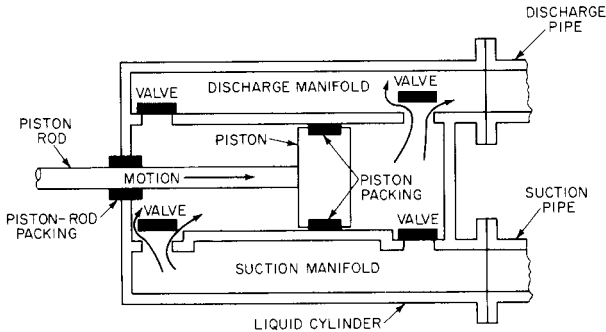


FIGURE 4 Schematic of a double-acting liquid end

to a liquid cylinder liner by pistons with packing. It has two suction and two discharge valves, one of each on each side of the piston. The piston is moved by a piston rod. The piston rod packing prevents liquid from leaking out of the cylinder. When the piston rod and piston are moved in the direction shown, the right side of the piston is on a *discharge stroke* and the left side of the piston is simultaneously on a *suction stroke*. The piston packing must seal tightly to the cylinder liner to prevent leakage of liquid from the high-pressure right side to the low-pressure left side.

The piston must be stopped before it hits the right side of the cylinder. The motion of the piston is then reversed so the left side of the piston begins its discharge stroke and the right side begins its suction stroke.

A reciprocating pump is not complete with a liquid end only; it must also have a driving mechanism to provide motion and force to the plunger or piston. The two most common driving mechanisms are a reciprocating steam engine and a crank-and-throw device. Those pumps using the steam engine are called *direct-acting steam pumps*. Those pumps using the crank-and-throw device are called *power pumps*. Power pumps must be connected to an external rotating driving force, such as an electric motor, steam turbine, or internal combustion engine.

### **DIRECT-ACTING STEAM PUMPS**

---

Direct-acting steam pumps are mainly classified by the number of working combinations of cylinders. For example, a duplex pump (Figure 5) has two steam and two liquid cylinders mounted side by side, and a simplex pump (Figure 6) has one steam and one liquid cylinder.

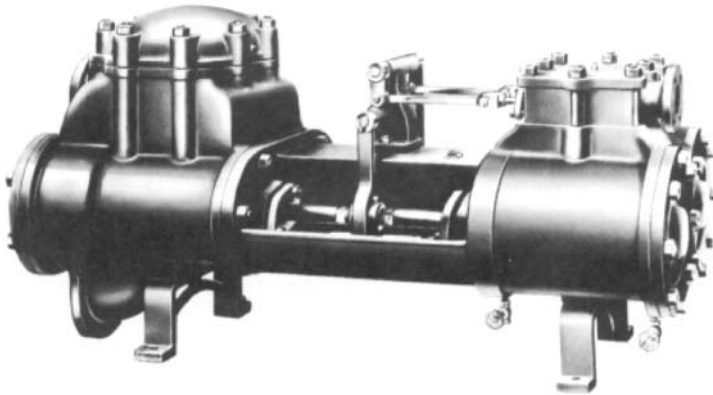
Additionally, simplex and duplex pumps may be further defined by (1) cylinder arrangement, whether horizontal or vertical; (2) number of steam expansions in the power end; (3) liquid end arrangement, whether piston or plunger; and (4) valve arrangement, that is, cap and valve plate, side pot, turret type, and so on.

Although this section will refer to steam as the driving medium, compressed gases such as air or natural gas can be used to drive a steam pump. These gases should have oil or mist added to them prior to entering the pump to prevent wear of the steam end parts.

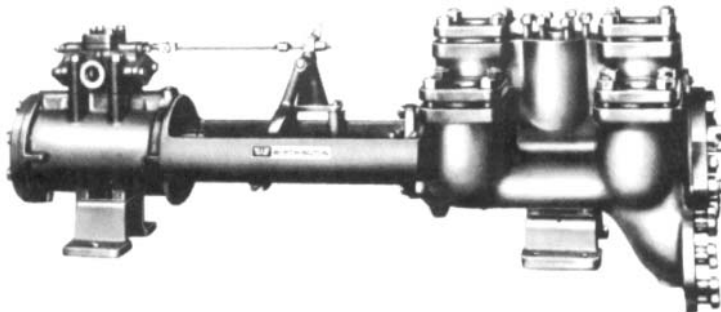
### **STEAM END CONSTRUCTION AND OPERATION**

---

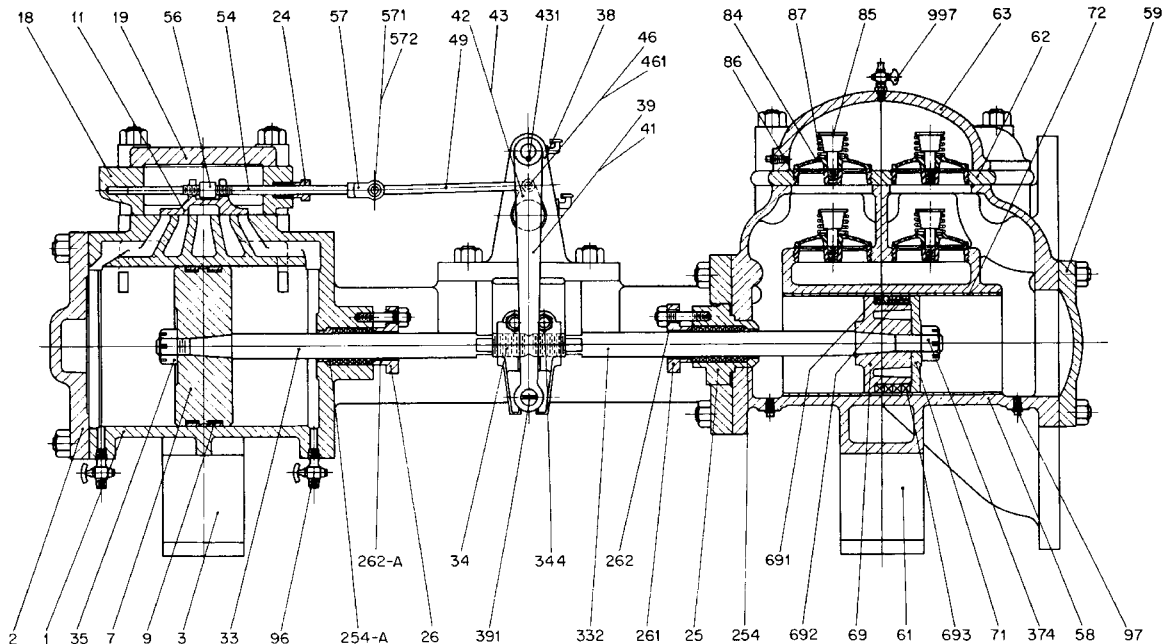
The driving mechanism, or *steam end*, of a direct-acting steam pump includes the following components, as illustrated in Figure 7:



**FIGURE 5** Duplex steam pump



**FIGURE 6** Simplex steam pump (Flowsolve Corporation)



**FIGURE 7** Typical section of duplex steam pump: (1) Steam cylinder with cradle, (2) steam cylinder head, (3) steam cylinder foot, (7) steam piston, (9) steam piston rings, (11) slide valve, (18) steam chest, (19) steam chest cover, (24) valve rod stuffing box gland, (25) piston rod stuffing box, liquid, (26) piston rod stuffing box gland, steam, (33) steam piston rod, (34) steam piston spool, (35) steam piston nut, (38) cross stand, (39) long lever, (41) short lever, (42) upper rock shaft, long crank, (43) lower rock shaft, short crank, (46) crank pin, (49) valve rod link, (54) valve rod, (56) valve rod nut, (57) valve rod head, (58) liquid cylinder, (59) liquid cylinder head, (61) liquid cylinder foot, (62) valve plate, (63) force chamber, (69) liquid piston body, (71) liquid piston follower, (72) liquid cylinder lining, (84) metal valve, (85) valve guard, (86) valve seat, (87) valve spring, (96) drain valve for steam end, (97) drain plug for liquid end, (254) liquid piston rod stuffing box bushing, (332) liquid piston rod, (344) piston rod spool bolt, (374) liquid piston rod nut, (391) lever pin, (431) lever key, (461) crank pin nut, (571) valve rod head pin, (572) valve rod head pin nut, (691) liquid piston snap rings, (692) liquid piston bull rings, (693) liquid piston fibrous packing rings, (997) air cock, (251) liquid piston rod stuffing box, (254A) steam piston rod stuffing box bushing, (261) piston rod stuffing box gland, liquid, (262) piston rod stuffing box gland lining, liquid, (262A) piston rod stuffing box gland lining, steam (Flowserve Corporation)

1. One or more steam cylinders with suitable steam inlet and exhaust connections
2. Steam piston with rings
3. Steam piston rods directly connected to liquid piston rods
4. Steam valves that direct steam into and exhaust steam from the steam cylinder
5. A steam valve actuating mechanism that moves the steam valve in proper sequence to produce reciprocating motion

The operation of a steam pump is quite simple. The motion of the piston is obtained by admitting steam of sufficient pressure to one side of the steam piston while simultaneously exhausting steam from the other side of the piston. There is very little expansion of the steam because it is admitted at a constant rate throughout the stroke. The moving parts, that is, the steam piston, the liquid piston, and the piston rod or rods, are cushioned and brought to rest by exhaust steam trapped in the end of the steam cylinder at the end of each stroke. After a brief pause at the end of the stroke, steam is admitted to the opposite side of the piston and the pump strokes in the opposite direction.

**Steam Valves** Because the steam valve and its actuating mechanism control the reciprocating motion, any detailed description of the construction of the direct-acting steam pump should rightfully begin with a discussion of steam valve types, operation, and construction.

**Duplex Steam Valves** The steam valves in a duplex steam pump are less complicated than those in a simplex pump and will be described first. As previously stated, the duplex steam pump can be considered as two simplex pumps arranged side by side and combined to operate as a single unit. The piston rod of one pump, in making its stroke, actuates the steam valve and thereby controls the admission or exhaust of steam in the second pump. A valve gear cross stand assembly is shown in Figure 8. The wishbone-shaped piston rod lever of one side is connected by a shaft to the valve rod crank of the opposite side. The steam valve is connected to the valve rod crank by the steam valve rod and steam valve link. Through this assembly, the piston rod of one side moves the steam valve of the opposite side in the same direction. When the first pump has completed its stroke, it must pause until its own steam valve is actuated by the movement of the second pump before it can make its return stroke. Because one or the other steam cylinder port is always open, there is no “dead center” condition; hence, the pump is always ready to start when steam

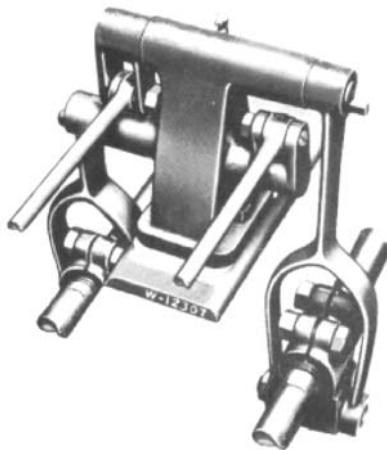


FIGURE 8 Steam valve actuating mechanism of a duplex pump (Flowsolve Corporation)

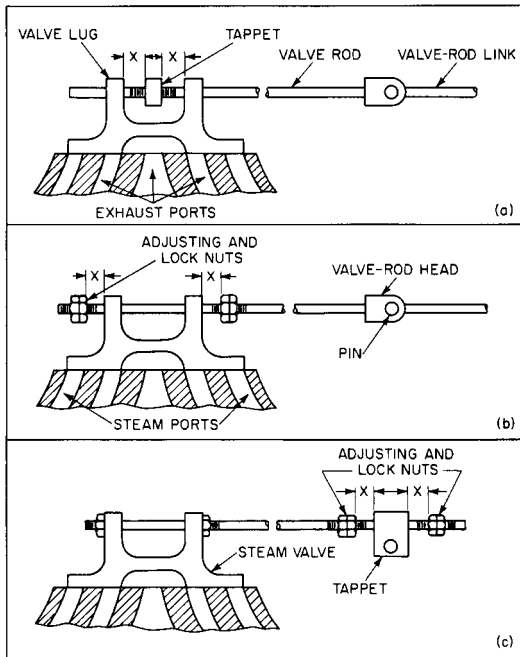


FIGURE 9A through C Duplex pump steam valve lost-motion arrangements

is admitted to the steam chest. The movements of both pistons are synchronized to produce a well-regulated flow of liquid free of excessive pulsations and interruptions.

**Flat Slide Steam Valves** Steam enters the pump from the steam pipe into the steam chest on top of the steam cylinder. Exhaust steam leaves the pump through the center port of five ports, as shown in Figure 9. Most duplex pumps use a flat slide valve that is held against its seat by steam pressure acting upon its entire top area; this is called an *unbalanced valve*. The flat or D valve, as it is often called, is satisfactory for steam pressures up to approximately 250 lb/in<sup>2</sup> (17 bar<sup>1</sup>) and has a reasonable service life, particularly where steam end lubrication is permissible. On large pumps, the force required to move an unbalanced valve is considerable, and so a balanced piston valve, which will be discussed later, is used.

The slide valve shown in Figure 9 is positioned on dead center over the five valve ports. A movement of the valve to the right uncovers the left-side steam port and the right-side exhaust port, which is connected through the slide valve to the center exhaust port. The main steam piston will be moved from left to right by the admitted steam. Movement of the slide valve from dead center to the left would, of course, cause opposite movement of the steam piston.

The steam valves of a duplex pump are mechanically operated, and their movements are dependent upon the motion of the piston rod and the linkage of the valve gear. In order to ensure that one piston will always be in motion when the other piston is reversing at the end of its stroke, lost motion is introduced into the valve gear. Lost motion is a means by which the piston can move during a portion of its stroke without moving the steam valve. Several lost motion arrangements are shown in Figure 9.

<sup>1</sup>1 bar = 10<sup>5</sup> Pa.



If the steam valves are out of adjustment, the pump will have a tendency not to operate through its designed stroke. Increasing the lost motion lengthens the stroke; if this is excessive, the piston will strike the cylinder head. Reducing the lost motion shortens the stroke; if this is excessive, the pump will short-stroke, with a resulting loss in capacity.

The first step in adjusting the valves is to have both steam pistons in a central position in the cylinder. To accomplish this, the piston is moved toward the steam end until the piston strikes the cylinder head. With the piston rod in this position, a mark is made on the rod flush with the steam end stuffing box gland. Next, the piston rod is moved toward the liquid end until the piston strikes, and then another mark is placed on the rod halfway between the first mark and the steam end stuffing box gland. After this, the piston rod is returned toward the steam end until the second mark is flush with the stuffing box gland. The steam piston is now in central position. This procedure is repeated for the opposite piston rod assembly.

The next step is to see that both steam valves are in a central position with equal amounts of lost motion on each side, indicated by distance  $X$  in Figure 9.

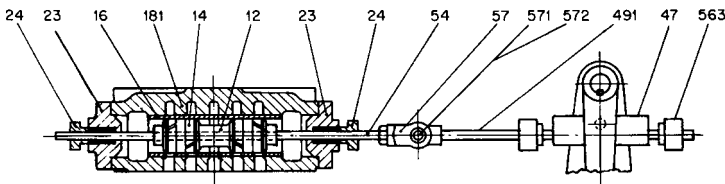
Most small steam pumps are fitted with a fixed amount of lost motion, as shown in Figure 9a. With the slide valve centered over the valve ports, a properly adjusted pump will have the tappet exactly centered in the space between the valve lugs. The lost motion ( $X$ ) on each side of the tappet will be equal.

Larger pumps are fitted with adjustable lost motions, such as are shown in Figure 9b. The amount of lost motion ( $X$ ) can be changed by moving the locknuts. Manufacturers provide specific instructions for setting proper lost motion. However, one rule of thumb is to allow half the width of the steam port on each side for lost motion. A method to provide equality of lost motion is to move the valve each way until it strikes the nut and then note if both port openings are the same.

In some cases, it is desirable to be able to adjust the steam valves while the pump is in motion. With the arrangements previously mentioned, this cannot be done because the steam chest head must be removed. In a pump equipped with a lost-motion mechanism such as that shown in Figure 9c, all adjustments are external and can therefore be made while the pump is in operation.

**Balanced Piston Steam Valve** The balanced piston steam valve (Figure 10) is used on duplex steam pumps when the slide-type valve cannot be used because of size. The balanced piston valve can also be used without lubrication at pressure above 250 lb/in<sup>2</sup> (17 bar) and temperatures above 500°F (260°C). At higher pressures, wire drawing or steam cutting can occur as the piston slowly crosses the steam ports. To prevent wear and permanent damage to the steam chest and piston, piston rings are used on the steam valve and a steam chest liner is pressed into the steam chest to protect it.

**Cushion Valves** Steam cushion valves are usually furnished on larger pumps to act as an added control to prevent the steam piston from striking the cylinder heads when the pump operates at high speeds. As previously shown, the steam end has five ports, the outside ports are for steam admission, and the inside ports are for steam exhaust. As the steam piston approaches the end of the cylinder, it covers the exhaust port, trapping a vol-



**FIGURE 10** Balanced piston steam valve: (12) piston valve, (181) steam chest, (23) valve rod stuffing box, (24) valve rod stuffing box gland, (54) valve rod, complete, (57) valve rod head, (14) piston valve ring, (16) piston valve lining, (47) lost-motion block tappet, (491) valve rod link, (563) valve rod collar (Flowsolve Corporation)

ume of steam in the end of the cylinder. This steam acts as a cushion and prevents the piston from striking the cylinder head. The cushion valve is simply a bypass valve between the steam and exhaust ports; by opening or closing this valve, the amount of cushion steam can be controlled.

If the pump is running at low speed or working under heavy load, the cushion valve should be opened as much as possible without allowing the piston to strike the cylinder head. If the pump is running at high speed or working under light load, the cushion valve should be closed. The amount of steam cushion and, consequently, the length of stroke can be properly regulated for different operating conditions by the adjustment of this valve.

**Simplex Steam Valves** The simplex pump steam valve is steam-operated, not mechanically operated as duplex steam valves are. The reason for this is that the piston rod assembly must operate its own steam valve. Consequently the travel of the valve cannot be controlled directly by means of the piston rod motion. Instead, the piston rod operates a pilot valve by means of a linkage similar to that used with a duplex pump. This controls the flow of steam to each end of the main valve, shuttling the steam back and forth. The arrangement illustrated in Figure 11 is one of the designs available to produce this motion.

With the pilot valve in the position shown in Figure 11, steam from the live steam space flows through the pilot valve steam port into the steam space at the left-hand end of the main valve (balanced piston type). Simultaneously, the D section of the pilot valve connects the steam space at the right-hand end of the main valve with the exhaust port, thereby releasing the trapped steam. The main valve has moved completely across to the right end of the chest. The main valve in this position permits steam to flow from the chest to the left steam cylinder port and, at the same time, connects the right steam cylinder port with the exhaust port.

The steam piston now moves to the right, and after the lost motion is taken up in the valve gear, the pilot valve moves to the left. In this position, the cycle previously described now takes place at the opposite end of the steam chest. Because the main valve is steam-operated, it can be in only two positions, either at the left-hand or at the right-hand end of the chest. Hence, it is impossible to have it at dead center. In other words, steam can always flow either to one side or to the other of the steam piston, regardless of the position of the steam piston.

For the valve to operate smoothly and quietly, an arrangement must be provided to create a cushioning effect on the valve travel. The steam piston, as it approaches the end of its travel, cuts off the exhaust port and traps a certain amount of steam, which acts as a cushion and stops the steam piston.

All valve adjustments are outside of the steam chest, and so it is possible to adjust the valve while the pump is in operation. The effect of decreasing or increasing the lost motion is the same as that described for duplex pumps. The lost-motion arrangement is the same as that shown in Figure 9c.

**Steam End Materials** For most services, cast iron is an excellent material for the steam cylinder and it is the major element of the steam end. It is readily cast in the complicated shape required to provide the steam porting. It possesses good wearing qualities, largely because of its free graphite content. This is required in the piston bores, which are continuously being rubbed by the piston rings. At high steam temperatures and pressures, ductile iron or steel is used. In the latter case, however, cast iron steam cylinder liners are frequently used because of their better wear resistance.

Counterbores are provided at each end of a steam cylinder so the leading piston ring can override, for a part of its width, the end of the cylinder bore to prevent the wearing of a shoulder on the bore.

The cylinder heads and steam pistons are also usually made of cast iron. The cylinder head has a pocket cast in it to receive the piston rod nut at the end of the stroke. Most steam pistons are made in one piece, usually with two piston ring slots machined into the outside circumference.

The relatively wide piston rings are usually made from hammered iron. They are split so they can be expanded to fit over the piston and snapped into the grooves in the piston.

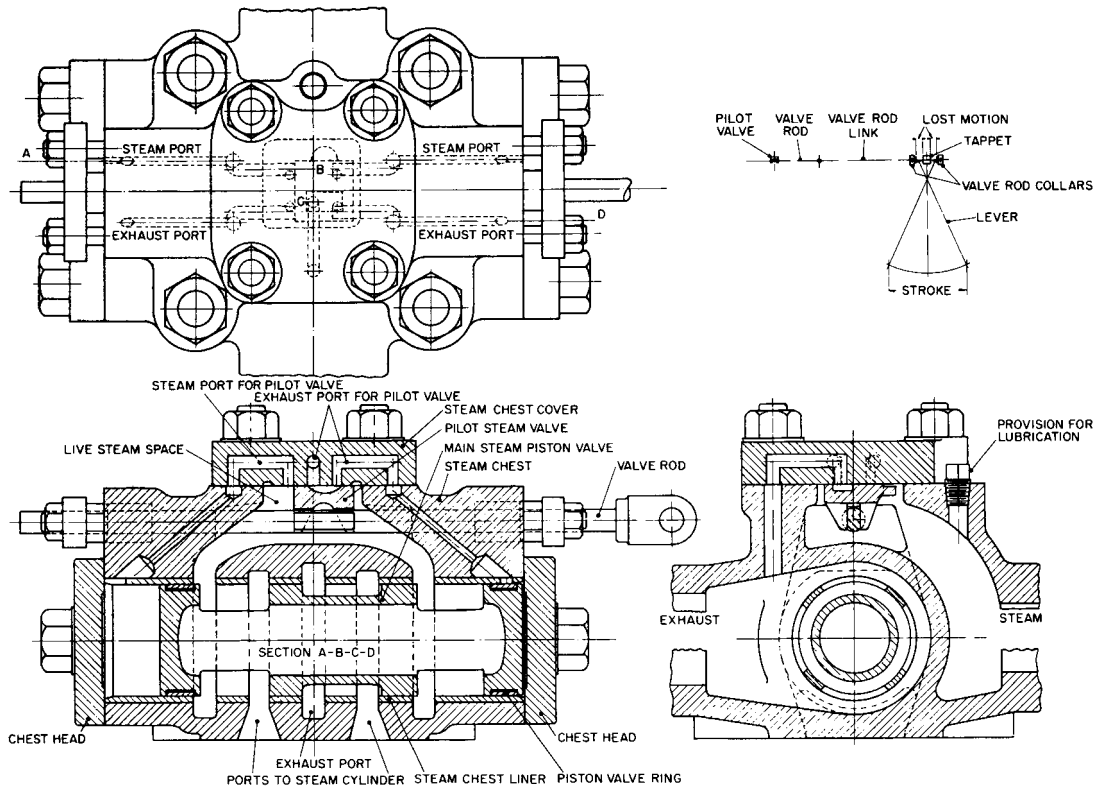


FIGURE 11 Simplex-type steam valve (Flowserve Corporation)

They must be compressed slightly to fit into the bores in the cylinder. This ensures a tight seal with the cylinder bores even as the rings wear during operation. In services where steam cylinder lubrication is not permissible, a combination two-piece ring of iron and bronze is used to obtain longer life than is obtained with the hammered iron rings.

The piston and valve rods are generally made from steel, but stainless steel and Monel are also commonly used. Packing for the rods is usually a braided graphited asbestos.

Drain cocks and valves are always provided to permit drainage of condensation, which forms in the cylinder when a pump is stopped and cools down. On each start-up these must be cracked open until all liquid is drained and only steam comes out; they are then closed.

The steam end and liquid end are joined by a cradle. On most small pumps, the cradle is cast integrally with the steam end. On large pumps, it is a separate casting or fabricated weldment.

### LIQUID END CONSTRUCTION

Steam pumps are equipped with many types of liquid ends, each being designed for a particular service condition. However, they can all be classified into two basic types, the piston, or inside-packed, type and the plunger, or outside-packed, type.

The piston pump (Figure 7) is generally used for low and moderate pressures. Because the piston packing is located internally, the operator cannot see the leakage past it or make adjustments that could make the difference between good operation and packing failure. Generally, piston pumps can be used at higher pressures with noncorrosive liquids having good lubricating properties, such as oil, than with corrosive liquids, such as water.

Plunger pumps, illustrated in Figure 12, are usually favored for high-pressure and heavy-duty service. Plunger pumps have stuffing box packing and glands of the same type as those on the piston rods of piston pumps. All packing leakage is external, where it is a guide to adjustments that control the leakage and extend packing and plunger life. During operation, lubrication can be supplied to the external plunger packing to extend its life. Lubrication cannot be supplied to the piston packing rings on a piston pump.

**Piston-Type Liquid Ends** The most generally used piston pump is the cap-and-valve plate design, illustrated in Figure 7. This is usually built for low pressures and temperatures, although some designs are used at up to 350 lb/in<sup>2</sup> (246 bar) of discharge pressure and 350°F (177°C). The discharge valve units are mounted on a plate separate from the cylinder and have a port leading to the discharge connection. A dome-shaped cap, subject to discharge pressure, covers the discharge valve plate. The suction valve units are mounted in the cylinder directly below their respective discharge valves. A passage in the liquid cylinder leads from below the suction valves down between the cylinders of a duplex pump to the suction connection.

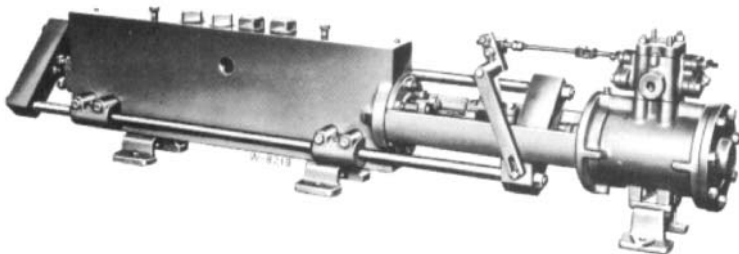


FIGURE 12 Simplex-type plunger pump (Flowsolve Corporation)

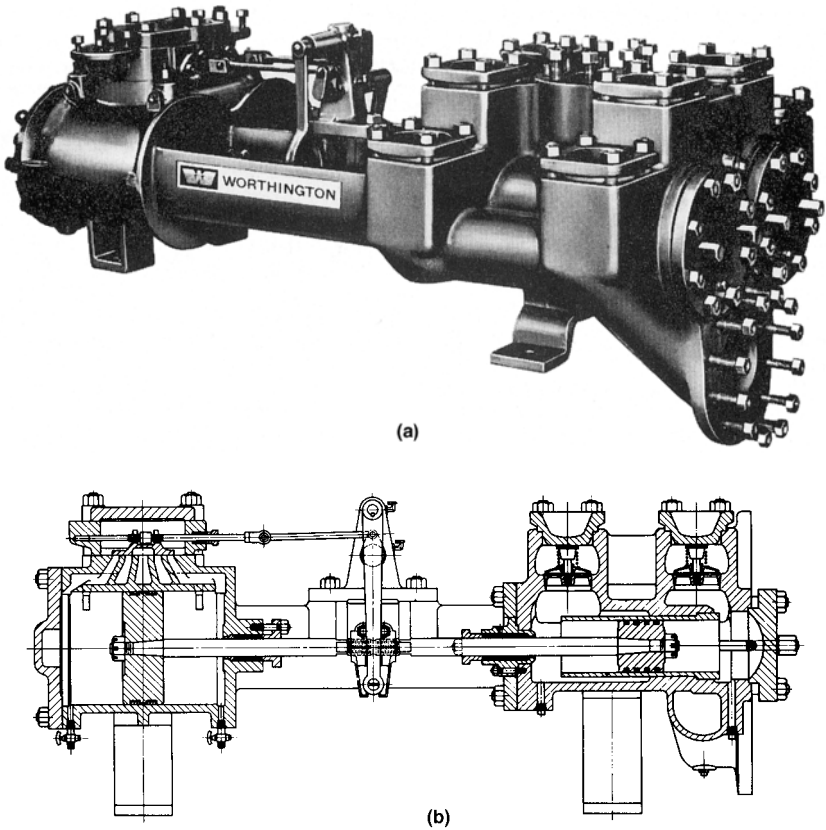


FIGURE 13A and B Side-pot piston pump (Flowsolve Corporation)

Side-pot liquid ends are used where the operating pressures are beyond the limitations of the cap-and-valve-plate pump. Figure 13 illustrates this design. Suction valves are placed in individual pots on the side of the cylinders and discharge valves in the pots above the cylinders. Each valve can be serviced individually by removing its cover. The small area of the valve covers exposed to discharge pressure makes the sealing much simpler than is the case in the cap-and-valve design. Side-pot liquid ends are widely used in refinery and oil field applications. This design is commonly employed to the maximum pressure practicable for a piston pump.

There are several specially designed piston-type liquid ends that have been developed for specific applications. One of these is the close-clearance design illustrated in Figures 14 and 15. This pump can handle volatile liquids, such as propane or butane, or a liquid that may contain entrained vapors.

The close-clearance cylinder is designed to minimize the dead space when the piston is at each end of its stroke. The liquid valves are placed as close as possible to the pump chamber to keep clearance to a minimum. The suction valves are positioned below the cylinder at the highest points in the suction manifold to ensure that all the gases are passed into the pump chamber. Although these pumps are of close-clearance design, they are not compressors and can vapor-bind; that is, a large amount of gas trapped below the discharge valve will compress and absorb the entire displacement of the pump. When this occurs, the dis-

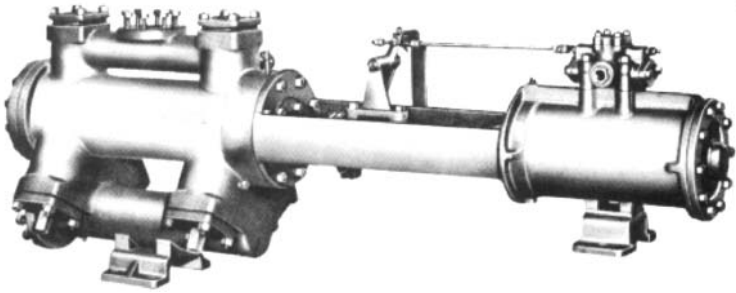


FIGURE 14 Close-clearance liquid end pump (FlowsERVE Corporation)

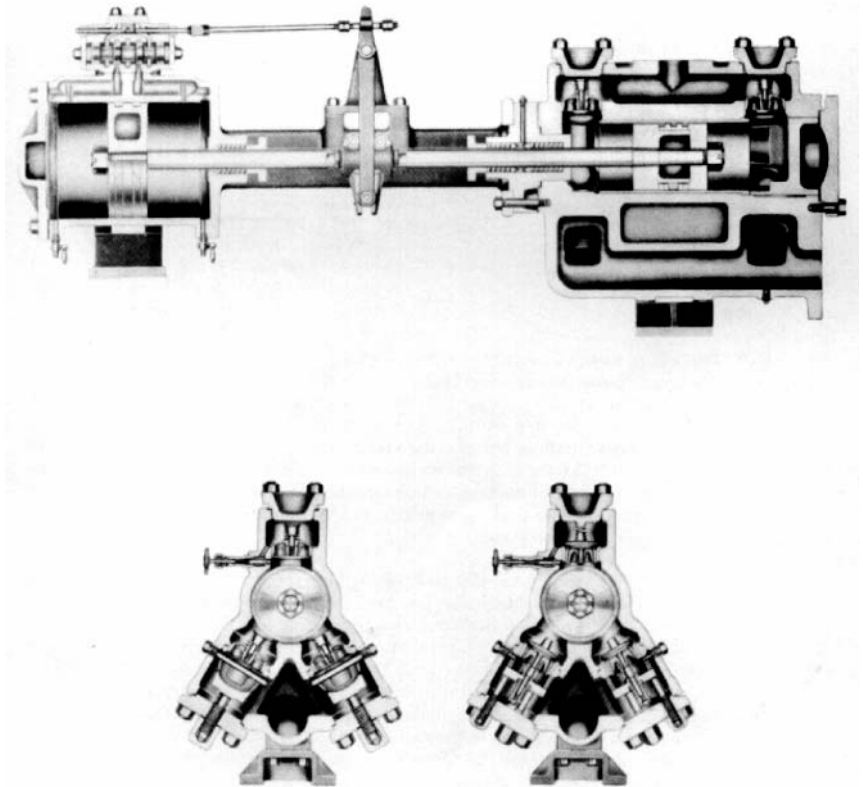


FIGURE 15 End views of close-clearance liquid end pump, showing disk valve assembly and wing valve assembly (FlowsERVE Corporation)

charge valve will not open and this will cause a loss of flow. Hand-operated bypass or priming valves are provided to bypass the discharge valve and permit the trapped gases to escape to the discharge manifold. When the pump is free of vapors, the valves are closed.

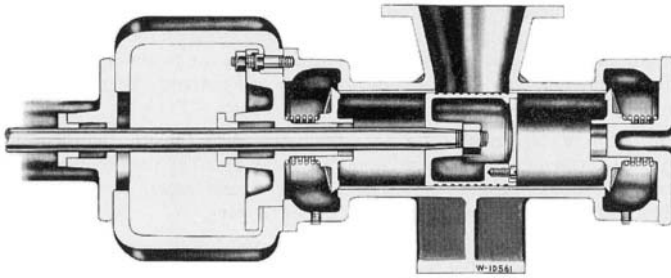


FIGURE 16 A pump for handling viscous liquid (Flowserve Corporation)

TABLE 1 Material and service specifications for pump liquid ends

Part	Regular fitted (RF)	Bronze fitted (BF)	Fully bronze fitted (FBF)	All iron fitted (AIF)	All bronze (AB)
Cylinders	Cast iron	Cast iron	Cast iron	Cast iron	Bronze
Cylinder liners	Bronze	Bronze	Bronze	Cast iron	Bronze
Piston	Cast iron	Cast iron	Bronze	Cast iron	Bronze
Piston packing	Fibrous	Fibrous	Fibrous	Cast-iron, 3-ring	Fibrous
Stuffing box	Cast iron, bronze bushed	Cast iron, bronze bushed	Cast iron, bronze bushed	Cast iron	Bronze
Piston rod	Steel	Bronze	Bronze	Steel	Bronze
Valve service	Bronze	Bronze	Bronze	Steel	Bronze
Services for which most often used	Cold water; other cold liquids not corrosive to iron and bronze	Same as for RF, with reduced maintenance; continuous hot water	Boiler feed; intermittent hot-water; sodium chloride, brines	Oils and other hydrocarbons not corrosive to iron or steel; caustic solutions	Mild acids that would attack iron cylinders but not acid-resisting bronze

There are a number of other special piston pump designs for certain services in addition to the most common types just described. One of these special designs is the wet vacuum pump, which features tight-sealing rubber valves that permit the pump to handle liquid and air or non-condensable vapors. Another special design is made of hard, wear-resistant materials to pump cement grout on construction projects. Another design, shown in Figure 16, has no suction valves and is made for handling viscous products such as sugarcane pulp, soap, white lead, printer's ink, and tar. The liquid flows into the cylinder from above through a suction port that is cut off as the piston moves back and forth.

**Piston Pump Liquid End Materials and Construction** The materials used for piston pump liquid ends vary widely with the liquids handled. Most of the services to which these pumps are applied use one of the common material combinations listed in Table 1.



The liquid cylinder, the largest liquid end component, is most frequently made from cast iron or bronze. However, other materials are also used. Cast steel cylinders are used in refineries and chemical plants for high-pressure and high-temperature applications. Nickel cast steels are used for low-temperature services. Ni-Resist cast iron, chrome-alloy steels, and stainless steels are occasionally used for certain corrosive and abrasive applications, but tend to make pump cost very high. The liquid cylinder heads and valve covers are usually made from the same material as the liquid cylinder.

As was the case in the steam end, a liquid cylinder liner is used to prevent wear and permanent damage to the liquid cylinder. Liners must be replaced periodically when worn by the piston packing to the point that too much fluid leaks from one side of the piston to the other. The liners may be either of a driven-in (or pressed-in) type or of a removable type, which is bolted or clamped in position in the cylinder bore.

The pressed-in type (Figure 7) derives its entire support from the drive fit in the cylinder bore. As a rule, such a liner is relatively thin and is commonly made from a centrifugal casting or a cold-drawn brass tube. After a driven liner is worn to the point where it must be replaced, it is usually removed by chipping a narrow groove along its entire length. This groove is cut as closely as possible through the liner without damaging the wall of the cylinder bore. A flange on the liner fits into a recess at the beginning of the cylinder bore. This flange is held in contact with a shoulder by jack bolts or a spacer between the cylinder head and the end of the liner. Sometimes a packing ring is used between the flange and shoulder for a positive seal. Removable liners are heavier than pressed-in ones.

There are several designs of pistons and piston packings used for various applications. The three most common are as follows:

1. The body-and-follower type of piston with soft fibrous packing or hard-formed composition rings (Figure 17). The packing is installed in the packing space on the piston with a clearance in both length and depth. This clearance permits fluid pressure to act on one end and the inside of the packing to hold and seal it against the other end of the packing space and the cylinder liner bore.
2. The solid piston or, as shown in Figure 18, a body and follower with rings of cast iron or other materials. This type is commonly used in pumps handling oil or other hydrocarbons. The metal rings are split with an angle or step-cut joint. Their natural tension keeps them in contact with the cylinder liner, assisted by fluid pressure under the ring.
3. The cup piston (Figure 19), which consists of a body-and-follower type of piston with molded cups of materials such as rubber reinforced with fabric. Fluid pressure on the inside of the cup presses the lip out against the cylinder bore, forming a tight seal.

The piston rod stuffing boxes are usually made separate from, but of the same material as, the liquid cylinder. When handling liquids with good lubrication properties, the stuffing boxes are usually packed full with a soft, square, braided packing that is compatible with the liquid. When the liquid has poor lubricating properties, a lantern ring is

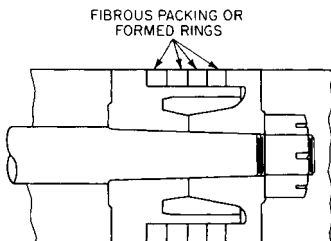


FIGURE 17 Body-and-follower piston

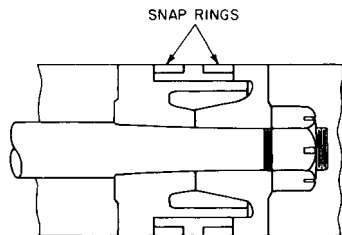


FIGURE 18 Body-and-follower piston with snap rings



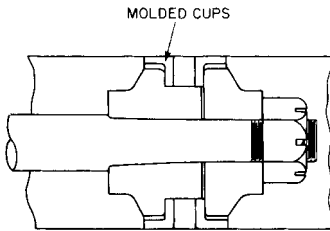


FIGURE 19 Body-and-follower piston with molded cups

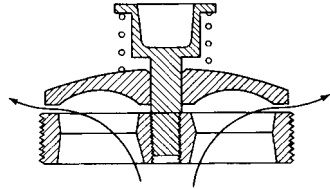


FIGURE 20 Stem-guided disk valve

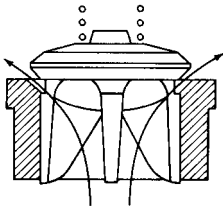


FIGURE 21 Wing-guided valve

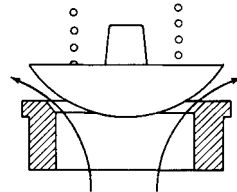


FIGURE 22 Semispherical valve

installed in the center of the stuffing box with packing rings on both sides of it. A drilled hole is provided through which a lubricant, grease or oil, can be injected into the lantern ring from the outside of the stuffing box. At higher temperatures, approximately 500°F (260°C) or higher, a cooling water jacket is added to the outside of the stuffing box or as a spacer between the stuffing box and the liquid cylinder. The purpose of the cooling water jacket is to extend packing life by keeping the packing cool.

The liquid end valves of all direct-acting steam pumps are self-acting, in contrast to the mechanically operated slide valves in the steam end. The liquid end valves act like check valves; they are opened by the liquid passing through and are closed by a spring plus their weight.

Liquid end valves are roughly divided into three types: the disk valve for general service and thin liquids, the wing-guided valves for high pressures, and either the ball or the semispherical valve for abrasive and viscous liquids.

The valve shown in Figure 20 is typical of the disk type. This stem-guided design is commonly used in the cap-and-plate design. For hot-water boiler-feed and general service, the disk, seat, and stem are usually made of bronze, although other alloys may also be used. For lower temperatures and pressures, the disk may be made of rubber, which has the advantage of always forming a tight seal with the valve seat.

The wing-guided valve shown in Figure 21 is typical of the design use for high pressures. It derives its name from the wings on the bottom of the valve, which guide it in its seat. The beveled seating surfaces on the valve and seat tend to form a tighter seal than the flat seating surfaces on a disk valve. There is also less danger that a solid foreign particle in the liquid will be trapped between the seat and the valve. This type of valve is commonly made from a heat-treated chrome-alloy-steel forging, although a cast hard bronze and other materials may be used.

The ball valve, as its name suggests, is a ball that acts like a check valve. It is usually not spring-loaded, but guides and lift stops are provided as necessary to control its operation. The ball may be made of rubber, bronze, stainless steel, or other materials as service conditions require. The semispherical valve (Figure 22) is spring-loaded and can therefore be operated at higher speeds than the ball valve. Both the ball and the semispherical type

have the advantage of having no obstructions to flow in the valve seat (the disk valve seat has ribs and the wing-guided valve has vanes which obstruct the flow). The one large opening in the seat and the smooth spherical surface of ball and semispherical valves minimize the resistance to flow of viscous liquids. These types are also used for liquids with suspended solids because their rolling seating action prevents trapping of the solids between the seat and valve.

**Plunger-Type Liquid Ends** As mentioned previously, plunger-type pumps are used where dependability is of prime importance, even when the pump is operated continuously for long periods and where the pressure is very high. Cast liquid end plunger pumps are used for low and moderate pressures. Forged liquid end pumps (Figure 23), which are the most common plunger types, are used for high pressures and have been built to handle pressures in excess of 10,000 lb/in<sup>2</sup> (69 MPa).

Most of these designs have opposed plungers; that is, one plunger operating into the inboard end of the liquid cylinder and one into the outboard end. The plungers are solidly secured to inboard and outboard plunger crossheads. The inboard and outboard plunger crossheads are joined by side rods positioned on each side of the cylinder. With this arrangement, each plunger is single-acting; that is, it makes only one pressure stroke for each complete reciprocating cycle. The pump, however, is double-acting because the plungers are connected by the side rods.

**PLUNGER PUMP LIQUID END MATERIALS** The liquid cylinder of a forged liquid end plunger-type pump is most commonly made from forged steel, although bronze, Monel, chrome alloy, and stainless steels are also used. The stuffing boxes and valve chambers are usually integral with the cylinder (Figure 23), which is desirable for higher temperatures and pressures because high-temperature joints are minimized.

The liquid plungers may be made of a number of materials. The plungers must be as hard and smooth as possible to reduce friction and to resist wear by the plunger packing. Hardened chrome-alloy steels and steel coated with hard-metal alloys or ceramics are most commonly used.

The stuffing box packing used will vary widely depending upon service conditions. A soft, square packing cut to size may be used. However, solid molded rings of square, V-lip, or U-lip design are commonly used at higher pressures. Oil or grease is frequently injected into a lantern ring in the center of the stuffing box to reduce friction and reduce packing and plunger wear.

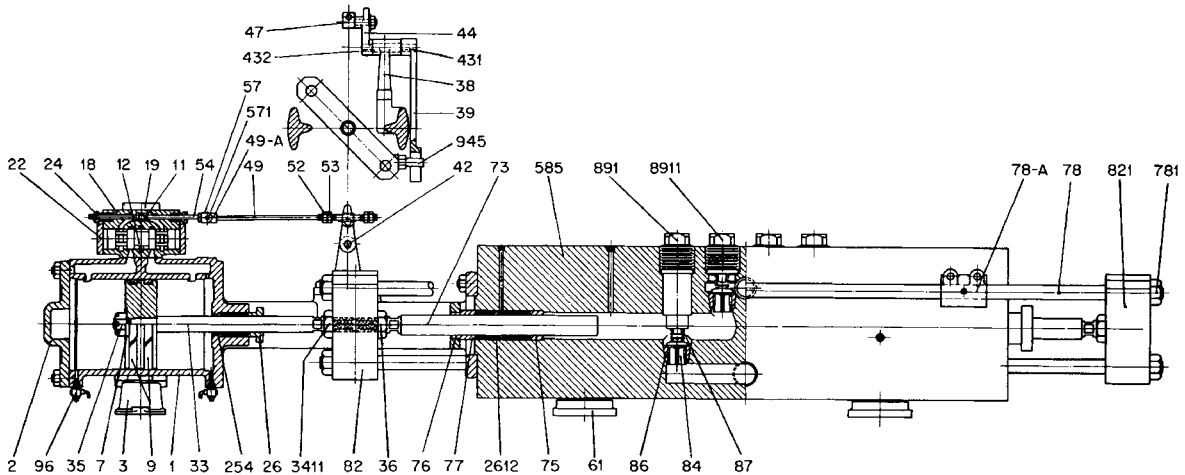
The liquid valves may be of any of the types or materials described above. However, the wing-guided valve with beveled seating surfaces is the most common because it is most suitable for high pressures.

### **DIRECT-ACTING STEAM PUMP PERFORMANCE** \_\_\_\_\_

The direct-acting steam pump is a very flexible machine. It can operate at any point of pressure and flow within the limitations of the particular design. The speed of, and therefore the flow from, the pump can be controlled from stop to maximum by throttling the steam supply. This can be done by either a manual or an automatically operated valve in the steam supply line. The maximum speed of a particular design is primarily limited by the frequency with which the liquid valves will open and close smoothly. The pump will operate against any pressure imposed upon it by the system it is serving, from zero to its maximum pressure rating. The maximum pressure rating of a particular design is determined by the strength of the liquid end. In a particular application, the maximum liquid pressure developed may be limited by the available steam pressure and by the ratio of the steam piston and liquid piston areas.

### **STEAM PUMP CAPACITY** \_\_\_\_\_

The flow to the discharge system is termed the pump *capacity*. The capacity, usually expressed in U.S. gallons per minute (cubic meters per minute), is somewhat less than the



**FIGURE 23** Simplex plunger pump with forged steel cylinder: (1) steam cylinder with cradle, (2) steam cylinder head, (3) steam cylinder foot, (7) steam piston, (9) steam piston rings, (11) slide valve, (12) piston valve, (18) steam chest, (19) steam chest cover, (22) steam chest head, (24) valve rod stuffing box gland, (26) steam piston rod stuffing box gland, (33) steam piston rod, (35) steam piston rod nut, (36) plunger nut, (38) cross stand, (39) lever, (42) fulcrum pin, (44) crank, (47) tappet, (49) valve rod link, (49A) valve rod link head, (52) lost-motion adjusting nut, (53) lost-motion locknut, (54) valve rod, (57) valve rod head, (61) liquid cylinder foot, (73) plunger, (75) plunger lining, (76) plunger gland flange, (77) plunger gland lining, (78) side rod, (78A) side rod guide, (82) plunger crosshead, front; (84) metal valve, (86) valve seat, (87) valve spring, (96) steam cylinder drain valve, (254) piston rod stuffing box bushing, (431) lever key, (432) crank key, (571) valve rod head pin, (585) liquid cylinder, (781) side rod nut, (821) plunger crosshead, rear, (891) suction valve plug, (945) crosshead pin, (2612) lantern gland, (8911) discharge valve plug, (3411) steam piston rod jam nut (Flowsolve Corporation)

theoretical *displacement* of the pump. The difference between displacement and capacity is called *slip*. The displacement is a function of the area of the liquid piston and the speed at which the piston is moving.

The displacement of a single double-acting piston can be calculated from the formula

$$\text{in USCS units} \quad D = \frac{12 \times AS}{231} \text{ or } 0.0408 d^2 S$$

$$\text{in SI units} \quad D = 1 \times 10^{-6} \times AS$$

where  $D$  = displacement, gpm ( $\text{m}^3/\text{min}$ )

$A$  = area of piston or plunger,  $\text{in}^2$  ( $\text{mm}^2$ )

$S$  = piston speed, ft/min ( $\text{m}/\text{min}$ )

$d$  = diameter of the liquid piston or plunger, in ( $\text{mm}$ )

For a duplex double-acting pump,  $D$  is multiplied by 2. This formula neglects the area of the piston rod. For very accurate calculations, it is necessary to deduct the rod area from the piston area. This is normally not done, and the resultant loss is usually considered part of the slip.

The slip also includes losses due to leakage from the stuffing boxes, leakage across the piston on packed-piston pumps, and leakage back into the cylinder from the discharge side while the discharge valves are closing. Slip for a given pump is determined by a test. For a properly packed pump, slip is usually 3 to 5%. As a pump wears, slip will increase, but this can be compensated for by increasing the pump speed to maintain the desired capacity.

### **PISTON SPEED**

---

Although piston speed in feet per minute (meters per minute) is the accepted term used to express steam pump speed, it cannot easily be measured directly and is usually calculated by measuring the revolutions per minute of the pump and converting this to piston speed. One revolution of a steam pump is defined as one complete forward and reverse stroke of the piston. The relationship between piston speed and rpm is

$$\text{in USCS units} \quad S = \frac{\text{rpm} \times \text{stroke}}{6}$$

$$\text{in SI units} \quad S = 0.002 \times \text{rpm} \times \text{stroke}$$

where  $S$  = piston speed, ft/min ( $\text{m}/\text{min}$ )

rpm = revolutions per minute

stroke = stroke of pump, in ( $\text{mm}$ )

A steam pump must fill with liquid from the suction supply on each stroke, or it will not perform properly. If the pump runs too fast, the liquid cannot flow through the suction line, pump passageways, and valves fast enough to follow the piston. On the basis of experience and hydraulic formulas, maximum piston speeds that vary with the length of stroke and the liquid handled can be established.

Table 2 shows general averages of maximum speed ratings for pumps of specified stroke handling various liquids. Some pumps, by reason of exceptionally large valve areas or other design features, may be perfectly suitable for speeds higher than shown. From the table, it should be noted that piston speed should be reduced for viscous liquids. Unless the net positive suction head is proportionately high, viscous liquids will not follow the piston at high speeds because frictional resistance in suction lines and in the pump increases with viscosity and rate of flow. Pumps handling hot water are run more slowly to prevent boiling of the liquid as it flows into the low-pressure area behind the piston.

**TABLE 2** Average maximum speed ratings

Stroke length, in*	Piston speed, ft/min*					Boiler feed 212°F (100°C)
	Cold water; oil to 250 SSU	Oil, 250–500 SSU	Oil, 500–1000 SSU	Oil, 1000–2500 SSU	Oil, 2500–5000 SSU	
3	37	35	33	29	24	22
4	47	45	42	36	31	28
5	53	51	47	41	35	32
6	60	57	53	46	39	36
7	64	61	57	49	42	39
8	68	65	61	53	45	41
10	75	72	67	58	49	45
12	80	77	71	62	52	48
15	90	86	80	69	57	54
18	95	91	85	73	62	57
24	105	100	94	81	68	63
36	120	115	107	92	78	72

\*SI conversion factors: in  $\times$  25.4 = mm; ft/min  $\times$  0.3048 = m/min.

### SIZE OF LIQUID END

The size of a steam pump is always designated as follows:

Steam piston diameter  $\times$  liquid piston diameter  $\times$  stroke

For example, a  $\frac{1}{2} \times 5 \times 6$  steam pump has a  $7\frac{1}{2}$ -in (191-mm) diameter steam piston, a 5-in (127-mm) diameter liquid piston, and a 6-in (152-mm) stroke.

To determine the liquid piston diameter for a specified capacity, the following procedure is used. First, a reasonable stroke length is assumed and the maximum piston speed for this stroke and the type of liquid pumped is selected from Table 2. Then the desired capacity is increased by 3 to 5% to account for slip. The result is the desired displacement. Then for either a simplex or duplex pump, the liquid piston diameter can be calculated as follows:

$$\text{In USCS units, for simplex pumps: } d_l = 4.95 \left( \frac{D}{S} \right)^{1/2}$$

$$\text{For duplex pumps: } d_l = 3.5 \left( \frac{D}{S} \right)^{1/2}$$

$$\text{In SI units, for simplex pumps: } d_l = 1128.4 \left( \frac{D}{S} \right)^{1/2}$$

$$\text{For duplex pumps: } d_l = 797.9 \left( \frac{D}{S} \right)^{1/2}$$

where  $d_l$  = liquid piston diameter, in (mm)

$D$  = displacement, gpm ( $\text{m}^3/\text{min}$ )

$S$  = piston speed, ft/min (m/min)

Using the resultant liquid piston diameter, the next larger standard piston size is selected.

## SIZE OF STEAM END

To calculate the size of the steam end required for a specific application, the basic principle of steam pump operation should be considered. A simple schematic of a steam pump is shown in Figure 24.

In order for the pump to move, the force exerted on the steam piston must exceed the force on the liquid piston that is opposing it. The force on the steam piston is the product of the net steam pressure and the steam piston area. The *net* steam pressure is the steam inlet pressure minus the exhaust pressure. The force acting on the liquid piston is the product of the net liquid pressure and the liquid piston area. The *net* liquid pressure is the pump discharge pressure minus the suction pressure or *plus* the suction lift. This may be expressed algebraically as follows:

$$P_s A_s > P_l A_l$$

where  $P_s$  = net steam pressure, lb/in<sup>2</sup> (bar)

$A_s$  = steam piston area, in<sup>2</sup> (mm<sup>2</sup>)

$P_l$  = net liquid pressure, lb/in<sup>2</sup> (bar)

$A_l$  = liquid piston area, in<sup>2</sup> (mm<sup>2</sup>)

Because the pistons are circular, the squares of their diameters are directly proportional to their areas, and the above formula can be rewritten as

$$P_s d_s^2 > P_l d_l^2$$

where  $d_s$  = steam piston diameter, in (mm)

$d_l$  = liquid piston diameter, in (mm)

In practice, it is necessary for the force on the steam piston to exceed the force opposing it on the liquid piston by a considerable amount. This is because of mechanical losses, which include stuffing box friction, friction between piston rings and cylinder of both liquid and steam ends, and the operation of the valve gear. These losses are determined by testing and are accounted for in size calculations by introduction of a mechanical efficiency figure. Mechanical efficiencies are expressed as a percentage, with 100% being a perfect balance of forces acting on the steam and liquid pistons as expressed in the previous formula. Because the efficiencies of two identical pumps may vary with stuffing box and piston ring packing tightness, the efficiencies published by manufacturers tend to be conservative.

With the mechanical efficiency factor inserted, the formula of forces becomes

$$P_s d_s^2 E_m = P_l d_l^2$$

where  $P_s$  = net steam pressure, lb/in<sup>2</sup> (bar)

$d_s$  = steam piston diameter, in (mm)

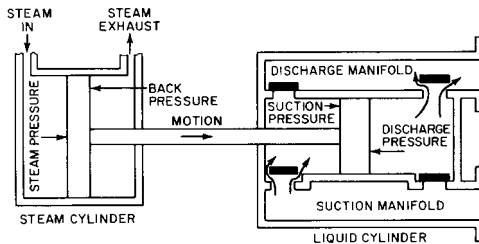


FIGURE 24 Schematic showing direction of forces on pistons

**TABLE 3** Typical mechanical efficiency values

Stroke length, in (mm)	Mechanical efficiency, %	
	Piston Pump	Plunger pump
3 (76)	50	47
4 (102)	55	52
5 (127)	60	57
6 (152)	65	61
8 (201)	65	61
10 (254)	70	66
12 (305)	70	66
18 (457)	73	69
24 (610)	75	71

$P_l$  = net liquid pressure, lb/in<sup>2</sup> (bar)

$d_l$  = liquid piston diameter, in (mm)

$E_m$  = mechanical efficiency, expressed as a decimal

This formula is commonly used to determine the *minimum* size of steam piston required when the liquid piston size has already been selected and the net steam and net liquid pressures are known. For this calculation, the formula is rearranged to the form

$$d_s = d_l \left( \frac{P_l}{P_s E_m} \right)^{1/2}$$

The efficiency of a long-stroke pump is greater than that of a short-stroke pump. Although mechanical efficiency varies with stroke length, any two pumps of the same size are capable of the same efficiency.

Table 3 shows typical mechanical efficiencies that can be used to determine required steam end size.

## STEAM CONSUMPTION AND WATER HORSEPOWER

After determining the proper size of other pump types, the next concern usually is to calculate the maximum brake horsepower so the proper size of driver can be selected. With a steam pump, the next step is usually to determine the steam consumption. This must be known to ensure that the boiler generating the steam is large enough to supply the steam required by the pump as well as that required for all its other services.

To determine the steam consumption, it is necessary first to calculate the water horsepower as follows:

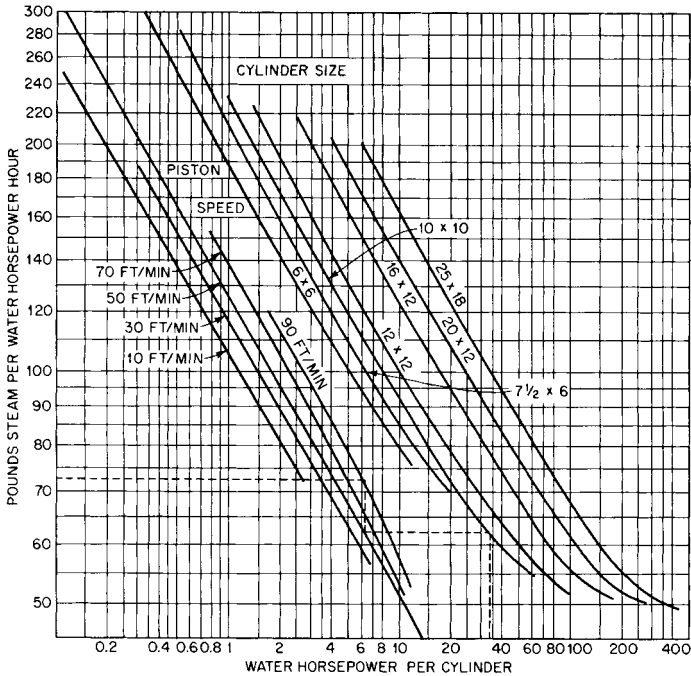
In USCS units 
$$whp = \frac{Q \times P_l}{1715}$$

In SI units 
$$kW = \frac{Q \times P_l}{36}$$

where  $whp$  = water horsepower

$Q$  = pump capacity, gpm (m<sup>3</sup>/h)

$P_l$  = net liquid pressure, lb/in<sup>2</sup> (bar)



**FIGURE 25** Approximate steam consumption for steam pumps (pounds of steam per water horsepower-hour = 1.644 kg of steam per water kilowatt-hour; water horsepower per cylinder = 1.341 kW per cylinder; ft/s = 0.3047 m/s; in = 25.44 mm) (Hydraulic Institute Standards, 12th Edition, 1969—out of print)

A steam consumption chart (Figure 25) affords a means of quickly obtaining an approximate figure for the steam rate of direct-acting steam pumps. For duplex pumps, divide the water horsepower by 2 before applying it to the curves. These curves were made up on the basis of water horsepower per cylinder; if the above procedure is not followed, the results will be inaccurate.

Starting with the water horsepower per cylinder:

1. Move vertically to the curve for steam cylinder size.
2. Move horizontally to the curve for 50-ft/min (15.15-m/min) piston speed. This is the basic curve from which the other curves were plotted.
3. Move vertically to the piston speed at which the pump will run.
4. Move horizontally to the steam rate scale and read it in pounds per water horsepower-hour (kilograms per kilowatt-hour).
5. Multiply the result by total water horsepower to obtain the steam rate in pounds per hour (kilograms per hour).

For steam cylinders with diameters as shown, but with longer stroke, deduct 1% from the steam rate for each 20% of additional stroke. Thus, a  $12 \times 24$  steam end will have a steam consumption about 5% less than a  $12 \times 12$  steam end. For  $5\frac{1}{4} \times 5$  and  $4\frac{1}{2} \times 4$  steam ends, the  $6 \times 6$  curve will give approximate figures. For cylinders of intermediate diameters, interpolate between the curves.

To correct for superheated steam, deduct 1% for each  $10^\circ$  of superheat. To correct for back pressure, multiply the steam rate by a correction factor equal to



$$\left( \frac{P + BP}{P} \right)^{1/2}$$

where  $P$  = net steam pressure to drive pump, lb/in<sup>2</sup> (bar)

$BP$  = back pressure, lb/in<sup>2</sup> (bar)

Direct-acting steam pumps have inherently high steam consumption. This is not necessarily a disadvantage, however, when the exhaust steam can be used for heating the boiler-feed water or for building heating or process work. Because these pumps can operate with a considerable range of back pressure, it is possible to recover nearly all the heat in the steam required to operate them. Because they do not use steam expansively, they are actually metering devices rather than heat engines and as such consume heat from the steam only as the heat is lost via radiation from the steam end of the pump. These pumps act, in effect, like a reducing valve to deliver lower pressure steam that contains nearly all its initial heat.

### SUCTION SYSTEMS AND NET POSITIVE SUCTION HEAD

A majority of pump engineers agree that most operating problems with pumps of all types are caused by failure to supply adequate suction pressure to fill the pump properly.

The steam pump industry uses the term *net positive suction head required (NPSHR)* to define the head, or pressure, required by the pump over its datum, usually the discharge valve level. This pressure is needed to (1) overcome frictional losses in the pump, (2) overcome the weight and spring loadings of the suction valves, and (3) create the desired velocity in the suction opening and through the suction valves. The *NPSHR* of a steam pump will increase as the piston speed and capacity are increased. The average steam pump will have valves designed to limit the *NPSHR* to 5 lb/in<sup>2</sup> (0.3 bar) (34.5 MPa) or less at maximum piston speed.

If the absolute pressure in the suction system minus the vapor pressure is inadequate to meet or exceed the *NPSHR*, the pump will cavitate. Cavitation is the change of a portion of the liquid to vapor, and it causes a reduction in delivered capacity, erratic discharge pressure, and noisy operation. Even minor cavitation will require frequent refacing of the valves, and severe cavitation can cause cracked cylinders or pistons or failure of other major parts.

### FLOW CHARACTERISTICS

The flow characteristics of duplex and simplex pumps are illustrated in Figure 26. The flow from a simplex pump is fairly constant except when the pump is at rest. However,

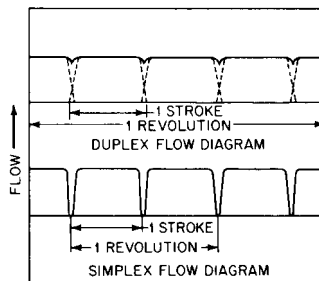


FIGURE 26 Flow characteristics of simplex and duplex pumps

because the flow must stop for the valves to close and for the forces on both sides of the steam and liquid pistons to reverse, there is uneven and pulsating flow. This can be compensated for, in part, by installing a pulsation-dampening device on the discharge side of the pump or in the discharge line.

In a duplex pump, one piston starts up just before the other piston completes its stroke, and the overlapping of the two strokes eliminates the sharp capacity drop.

### **FURTHER READING**

---

Grobholz, R. K. "Get the Right Steam Pump to Handle the Job." *Mill and Factory*, 1955.

American National Standard for Direct Acting (Steam) Pumps for Nomenclature, Definitions, Application and Operation, ANSI/HI 8.1-8.5-2000, Hydraulic Institute, Parsippany, NJ [www.pumps.org](http://www.pumps.org).

Schaub, D. G. "Reciprocating Steam Pumps." *South. Power and Ind.*, 1955.

Wright, E. F. "Direct-Acting Steam Pumps." In *Standard Handbook for Mechanical Engineers* (T. Baumeister and L. Marks, eds.), 7th ed., McGraw-Hill, New York, 1967, pp. 14–9 to 14–14.

Wright, E. F. In *Pump Questions and Answers*. (R. Carter, I. J. Karassik, and E. F. Wright, eds.) McGraw-Hill, New York, 1949.

---

# SECTION 3.4

---

# DISPLACEMENT PUMP PERFORMANCE, INSTRUMENTATION, AND DIAGNOSTICS

---

J. C. WACHEL  
FRED R. SZENASI

The most common operational and reliability problems in reciprocating positive displacement pump systems are characterized by

- Low net positive suction head (*NPSH*), pulsations, pressure surge, cavitation, waterhammer
- Vibrations of pump or piping
- Mechanical failures, wear, erosion, alignment
- High horsepower requirements, high motor current, torsional oscillations
- Temperature extremes, thermal cycling
- Harsh liquids: corrosive, caustic, colloidal suspensions, precipitates (slurries)

Although any component in a pump system may be defective, most operational problems are caused by liquid transient interaction of the piping system and pump system or by purely mechanical interaction of the pump, drive system, foundation, and so on. This section discusses hydraulic and mechanical problems and suggests measurement and diagnostic procedures for determining the sources of these problems.

## **HYDRAULIC AND MECHANICAL PUMP PROBLEMS**

---

**Inadequate NPSH** Net positive suction head available (*NPSHA*) is the static head plus atmospheric head minus lift loss, frictional loss, vapor pressure, and acceleration head available at the suction connection centerline.

Acceleration head can be the highest factor of *NPSHA*. In some cases, it is 10 times the total of all the other losses. Data from both the pump and the suction system are required

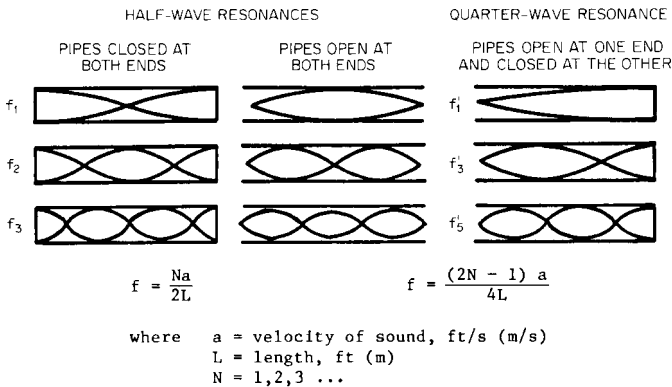


FIGURE 1 Organ pipe resonant mode shapes

to determine acceleration head; its value cannot be calculated until these data have been established. Inadequate *NPSH* can cause cavitation, the rapid collapse of vapor bubbles, which can result in a variety of pump problems, including noise, vibration, loss of head and capacity, and severe erosion of the valves and surfaces in the adjacent inlet areas. To avoid cavitation of liquid in the pump or piping, the absolute liquid static pressure at pumping temperatures must always exceed the vapor pressure of the liquid. The pressure at the pump suction should include sufficient margin to allow for the presence of pulsations as well as pressure losses due to flow.

**Positive Displacement Pump Pulsations** The intermittent flow of a liquid through pump internal valves generates liquid pulsations at integral multiples of the pump operating speed. For example, a 120-rpm triplex pump generates pulsations at all multiples of pump speed (2 Hz, 4 Hz, and so on); however, the most significant components will usually be multiples of the number of plungers (6 Hz, 12 Hz, 18 Hz, and so on). Resultant pulsation pressures in the piping system are determined by the interaction of the generated pulsation spectrum from the pump and the acoustic length resonances of liquid in the piping. For variable-speed units, the discrete frequency components change in frequency as a function of operating speed and the measured amplitude of any pulsation harmonic can vary substantially with changes in the location of the measurement point relative to the pressure nodes and antinodes of the standing wave pattern.

**Piping System Pulsation Response** Because acoustic liquid resonances occur in piping systems of finite length, these resonances will selectively amplify some pulsation frequencies and attenuate others. Resonances of individual piping segments can be described from organ pipe acoustic theory. The resonant frequencies of standing pressure waves depend upon the velocity of sound in the liquid being pumped, pipe length, and end conditions. The equations for calculating these frequencies are shown in Figure 1. All of the integral multiples ( $N$ ) of a resonance can occur, and it is desirable to mismatch the excitation frequencies from any acoustical resonances. A 2:1 diameter increase or greater would represent an open end for the smaller pipe. Closed valves, pumps, or a 2:1 diameter reduction represent closed ends. For example, a 2-in (51-mm) diameter pipe that connects radially into two 8-in (203-mm) diameter volumes would respond acoustically as an open-end pipe.

Complex piping system responses depend upon the termination impedances and interaction of acoustical resonances and cannot be handled with simplified equations. An electroacoustic analog<sup>1</sup> or digital computer can be used for the more complex systems.

**Velocity of Sound in Liquid Piping Systems** The acoustic velocity of liquids can be determined by the following equation:

$$a = C_1 \sqrt{\frac{K_s}{\text{sp. gr.}}} \quad (1)$$

where  $a$  = velocity of sound, ft/s (m/s)

$C_1$  = 8.615 for USCS units, 1.0 for SI units

$K_s$  = isentropic bulk modulus, lb/in<sup>2</sup> (kPa)

sp. gr. = specific gravity

In liquid piping systems, the acoustic velocity can be significantly affected by pipe wall flexibility. The acoustic velocity can be adjusted by the following equation:

$$a_{\text{adjusted}} = a \sqrt{\frac{1}{1 + \frac{DK_s}{tE}}} \quad (2)$$

where  $D$  = pipe diameter, in (mm)

$t$  = pipe wall thickness, in (mm)

$E$  = elastic modulus of pipe material, lb/in<sup>2</sup> (kPa)

Pipe wall radial compliance can reduce the velocity of sound in liquid in a pipe as shown in Figure 2.<sup>2</sup>

The bulk modulus of water can be calculated with the following equation<sup>3</sup> for temperatures from 0 to 212°F (0 to 100°C) and pressures from 0 to  $4.4 \times 10^4$  lb/in<sup>2</sup> (0 to 3 kbar\*):

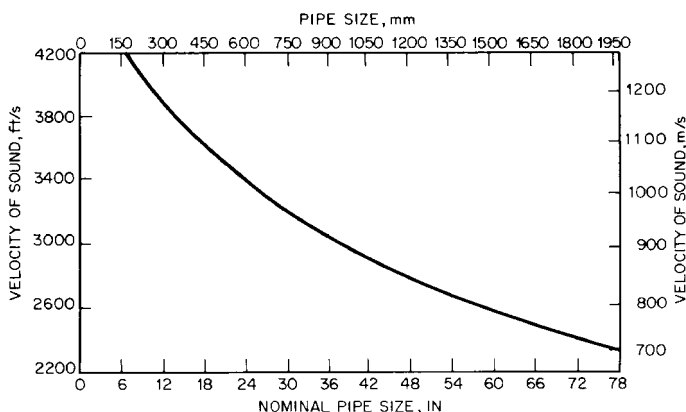
$$K_s = K_0 + 3.4P \quad (3)$$

where  $K_s$  = isentropic bulk modulus, kbar

$K_0$  = constant from Table 1, kbar

$P$  = pressure, kbar

(1 kbar =  $10^5$  kPa = 14,700 lb/in<sup>2</sup>)



**FIGURE 2** Velocity of sound in water at 14.6 lb/in<sup>2</sup> (1 bar), 60°F (15.6°C) versus nominal pipe size with 0.25-in (6.35-mm) wall thickness

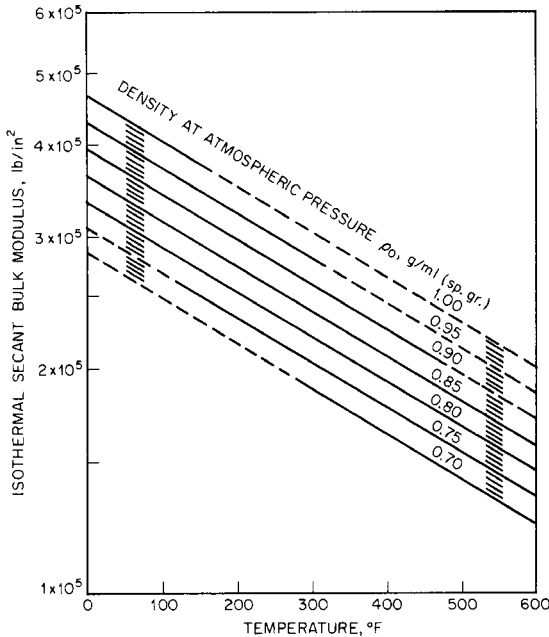
\*1 bar =  $10^5$  Pa.

**TABLE 1** Constant  $K_0$  for evaluation of isentropic bulk modulus of water from 0 to 3 kbar

Temperature, °C (°F)		Isentropic constant $K_0$ , kbar <sup>a</sup>
0	(32)	19.7
10	(50)	21.0
20	(68)	22.0
30	(86)	22.7
40	(104)	23.2
50	(122)	23.5
60	(140)	23.7
70	(158)	23.7
80	(176)	23.5
90	(194)	23.3
100	(212)	22.9

<sup>a</sup>1 kbar = 14,700 lb/in<sup>2</sup>.

Source: Reference 3.



**FIGURE 3** Isothermal secant bulk modulus at 20,000 lb/in<sup>2</sup> gage for petroleum oils (1 lb/in<sup>2</sup> = 6.895 kPa; °C = (°F - 32)/1.8).

The calculation of the isentropic bulk modulus of water is accurate to  $\pm 0.5\%$  at 68°F (20°C) and lower pressures.<sup>4</sup> At elevated pressures (greater than 3 kbar) and temperatures (greater than 100°C), the error should not exceed  $\pm 3\%$ .

The bulk modulus for petroleum oils (hydraulic fluids) can be obtained at various temperatures and pressures by using Figures 3 and 4, which were developed by the American

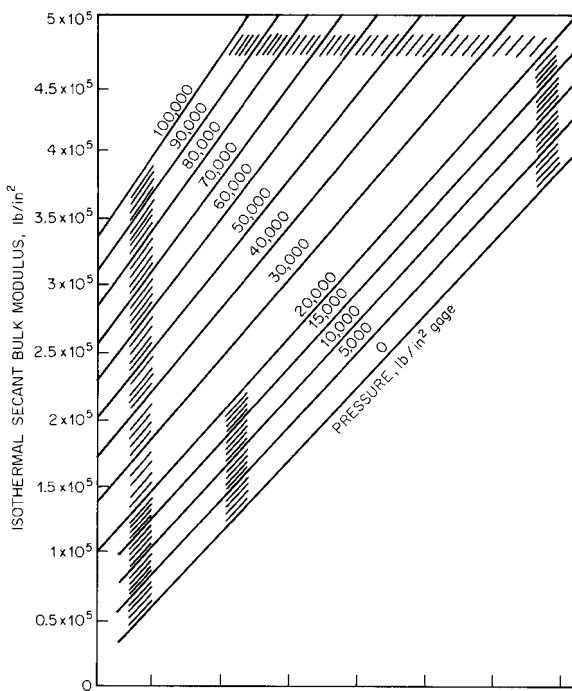


FIGURE 4 Pressure correction for isothermal secant bulk modulus for petroleum oils ( $1 \text{ lb/in}^2 = 6.895 \text{ kPa}$ )

Petroleum Institute (API).<sup>4-7</sup> Figure 3 relates density (mass per unit volume) and temperature to the isothermal secant bulk modulus at  $20,000 \text{ lb/in}^2$  ( $137,900 \text{ kPa}$ ), and Figure 4 corrects for various pressures.

The isentropic tangent bulk modulus is needed to calculate the speed of sound in hydraulic fluids and can be readily obtained from Figures 3 and 4 as follows:

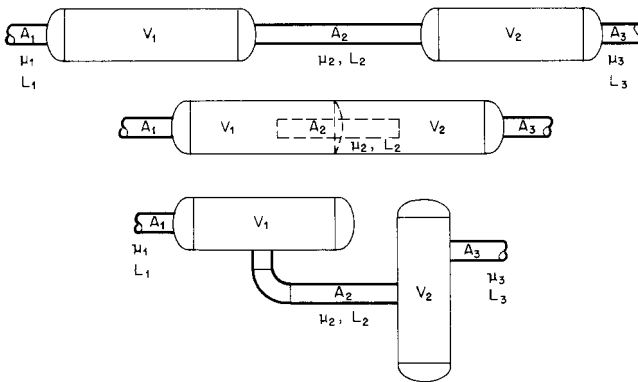
1. Read the isothermal secant bulk modulus at the desired temperature from Figure 3.
2. Using the value for isothermal secant bulk modulus obtained from Figure 3, go to Figure 4 and locate the intersection of the pressure line with that value. Move vertically to the pressure line representing twice the normal pressure. Read the adjusted isothermal secant bulk modulus for the double value of pressure.
3. Multiply the adjusted isothermal secant bulk modulus by 1.15 to obtain the value of the isentropic tangent bulk modulus (compensation for the ratio of specific heats).

The isothermal tangent bulk modulus has been shown to be approximately equal to the secant bulk modulus at twice the pressure<sup>5</sup> within  $\pm 1\%$ . The relationship between isothermal bulk modulus  $K_t$  and isentropic bulk modulus  $K_s$  is

$$K_s = K_t c_p / c_v \quad (4)$$

The value of  $c_p/c_v$  for most hydraulic fluids is approximately 1.15.

**Pulsation Control** Pulsation control can be achieved by judicious use of acoustic filters and side branch accumulators. Acoustic filters are liquid-filled devices consisting of volumes and chokes that use reactive filtering techniques to attenuate pulsations. Side



$$\mu_j = \frac{A_j}{L_j + 1/2 \sqrt{\pi A_j}} \quad \text{for } j = 1, 2, 3$$

$$f = \frac{a}{2\pi} \sqrt{\frac{1}{2} \left[ \frac{\mu_1 + \mu_2}{V_1} + \frac{\mu_2 + \mu_3}{V_2} \pm \sqrt{\left( \frac{\mu_1 + \mu_2}{V_1} - \frac{\mu_2 + \mu_3}{V_2} \right)^2 + \frac{4\mu_2^2}{V_1 V_2}} \right]}$$

FOR EQUAL VOLUMES, THE RESONANT FREQUENCY IS APPROXIMATELY:

$$f = \frac{a}{\sqrt{2} \pi} \sqrt{\frac{\mu_2}{V_1}}$$

**FIGURE 5** Two-chamber resonator system with both ends open.  $V$  = volume, ft<sup>3</sup> (m<sup>3</sup>);  $f$  = resonant frequency, Hz;  $L$  = choke tube length, ft (m);  $A$  = choke tube area, ft<sup>2</sup> (m<sup>2</sup>);  $a$  = acoustic velocity, ft/s (m/s);  $m$  = acoustic parameter.

branch resonators are of two types: quarter-wavelength resonant stubs and gas-charged accumulators. (The terms *accumulators*, *dampeners*, and *dampers* are used interchangeably in the liquid filter industry.)

**Acoustic Filters** An acoustic filter consisting of two volumes connected by a small-diameter choke can significantly reduce the transmission of pulsations from the pump into the suction and discharge piping systems. The equations given in Figure 5 can be used to calculate the resonant frequency for a simple volume-choke-volume filter. The filter should be designed to have a resonant frequency no more than one-half the lowest frequency desired to be reduced, referred to as the cutoff frequency. Such a filter is called a low-pass filter because it attenuates frequencies above the cutoff frequency.

A special case for symmetric liquid-filled filters can be obtained by choosing equal chamber and choke lengths. This reduces the equation in Figure 5 to

$$f = \frac{ad}{\pi \sqrt{2} CD} \quad (5)$$

where  $d$  = choke diameter, in (mm)

$L$  = chamber and choke length, ft (m)

$D$  = chamber diameter, in (mm)

Normally, a good filter design will have a resonant frequency less than one-half the plunger frequency and will have a minimal pressure drop. For example, a triplex pump running at 600 rpm generates pulsations at all multiples of 10 Hz. The largest amplitudes



would normally be at 30 Hz, 60 Hz, 90 Hz, and so on. The filter resonant frequency should be set at 15 Hz or lower. For water, in which the velocity of sound is 3200 ft/s (976 m/s), and a volume bottle size inner diameter of 19 in (482.6 mm),

$$\text{in USCS units} \quad \frac{L}{d} = \frac{3200}{\pi \sqrt{2} (15)(19)} = 2.53 \frac{\text{ft}}{\text{in}}$$

$$\text{in SI units} \quad \frac{L}{d} = \frac{976}{\pi \sqrt{2} (15)(482.6)} = 0.03 \frac{\text{m}}{\text{mm}} \quad (6)$$

If the choke diameter is selected to be 1.049 in (26.64 mm), the length of each volume bottle and choke tube is 2.65 ft (0.81 m). See also Reference 8.

**Side Branch Accumulators** Liquid-filled, quarter-wavelength, side branch accumulators reduce pulsations in a narrow frequency band and can be effective on constant/speed positive displacement pumps. However, in variable-speed systems, accumulators with or without a bladder can be made more effective by partially charging them with a gas (nitrogen or air) because the gas charge cushions hydraulic shocks and pulsations. If properly selected, located, tuned, and charged, a wide variety of accumulators (weight- or spring-loaded; gas-charged) can be used in positive displacement pump systems to prevent cavitation and waterhammer, damp pulsations, and reduce pressure surges.<sup>9,10</sup> Improper sizing or location can aggravate existing problems or cause additional ones. Typically, the best location for accumulators is as close to the pump as possible.

Gas-charged dampeners, or accumulators, such as those depicted in Figure 6, are most commonly used and can be quite effective in controlling pulsations. These devices are commercially available from several sources. Their location and volume and the pressure of the charge are important to their effectiveness. When gas-charged dampeners are used, the gas pressure must be monitored and maintained because the gas can be absorbed into the liquid. The system pressure can sometimes be lower than the gas charging pressure, such as on start-up; therefore, a valve should be installed to shut off the accumulator during start-up to eliminate gas leakage to the primary liquid. When the valve is closed, the accumulator is decoupled from the system and is not effective. Accumulators with integral check valves should be adjusted so pressure transients do not close the check valve and render the accumulator ineffective. Accumulators that have bladders (Figures 6b, d, and e) to separate the gas charge from the liquid have some distinct advantages, particularly if gas absorption is a problem. Accumulators with flexible bladders must be carefully maintained because failure of a bladder could release gas into the liquid system and could compromise the effectiveness of the dampener.

The in-line gas dampener (refer to Figure 6e) has a cylinder around the pipe containing a gas volume and bladder. The liquid enters the dampener through small holes in the circumference of the pipe and impinges upon the bladder, which produces the same acoustic effect as a side branch configuration.

It is not always possible to design effective pulsation control systems using simplified techniques. For complicated piping systems with multiple pumps, an electroacoustic

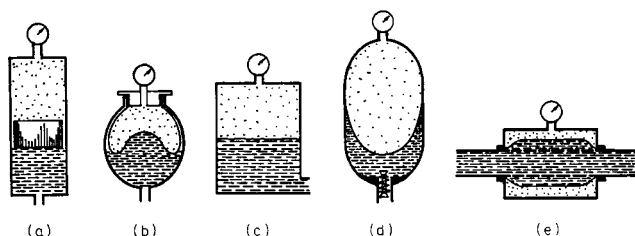


FIGURE 6 Types of accumulators: (a) piston, (b) diaphragm, (c) gas-charged, (d) bladder, (e) in-line

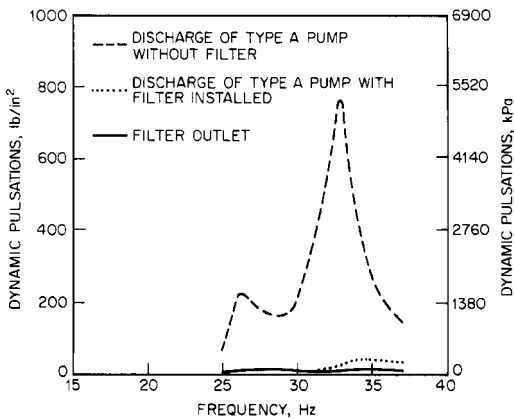


FIGURE 7 Effect of acoustic filter on pulsations

analog<sup>1</sup> is recommended for designing optimum filters or accumulators. This tool has become widely accepted for designing reliable piping systems for reciprocating liquid pumps and gas compressor units. The reduction in pulsations in a liquid pump system in a nuclear plant is shown in Figure 7. These results were obtained with a two-volume acoustic filter system designed with the electroacoustic analog. The volume diameter was 19.3 in (49 cm), and the length was 4 ft (1.2 m). The choke tube diameter was 0.8 in (2 cm), and its length was 7 ft (2.1 m). The speed of the triplex (2-cm) pump was 360 rpm, and the filter resonant frequency was set at 8.1 Hz for a velocity of sound of 4550 ft/s (1390 m/s).

**Piping Vibrations** When mechanical resonances are excited by pulsations, vibrations in the pump and piping can sometimes be 20 times higher than under off-resonant conditions. When the mechanical resonances coincide with the acoustic resonances, an additional amplification factor as high as 300 can be encountered.

Piping system mechanical natural frequencies can be calculated using simplified design procedures to provide effective detuning from known excitation sources. A nomogram (see Figure 8) for calculating the lowest natural frequency of uniform steel piping spans<sup>11</sup> can be used in designing piping systems and in diagnosing and solving vibration problems. For example, welded between two bottles, a 4-in (102-mm) pipe that is 10 ft (3 m) long and has an inner diameter of 3.826 in (97.18 mm) would have a mechanical frequency of 74 Hz. If the pipe was an equal-leg L bend ( $L = 5$ ), the natural frequency would be 50 Hz.

To minimize piping vibration problems, all unnecessary bends (considering routing and thermal flexibility) should be eliminated because they provide a strong coupling point between pulsation excitation forces and the mechanical system. When bends are needed, use the largest enclosed angle possible and locate restraints near each bend. Piping should also have supports near all piping size reductions and at large masses (valves, accumulators, flanges, and so on). Small auxiliary piping connections (vents, drains, pressure test connections, and so on) should be designed so the mass of the valve and flange is effectively tied back to the main piping, thus eliminating relative vibration.

**Diagnostics and Instrumentation** The diagnosis of vibrations in positive displacement pumps should usually include dynamic pressure measurements in the cylinders and piping near the pump. These measurements can be obtained by the use of piezoelectric or strain gage pressure transducers. If cavitation or flashing is suspected, a pressure transducer capable of measuring static and large dynamic pressures should be used; even then, cavitation-produced pressure shocks may damage the transducer.

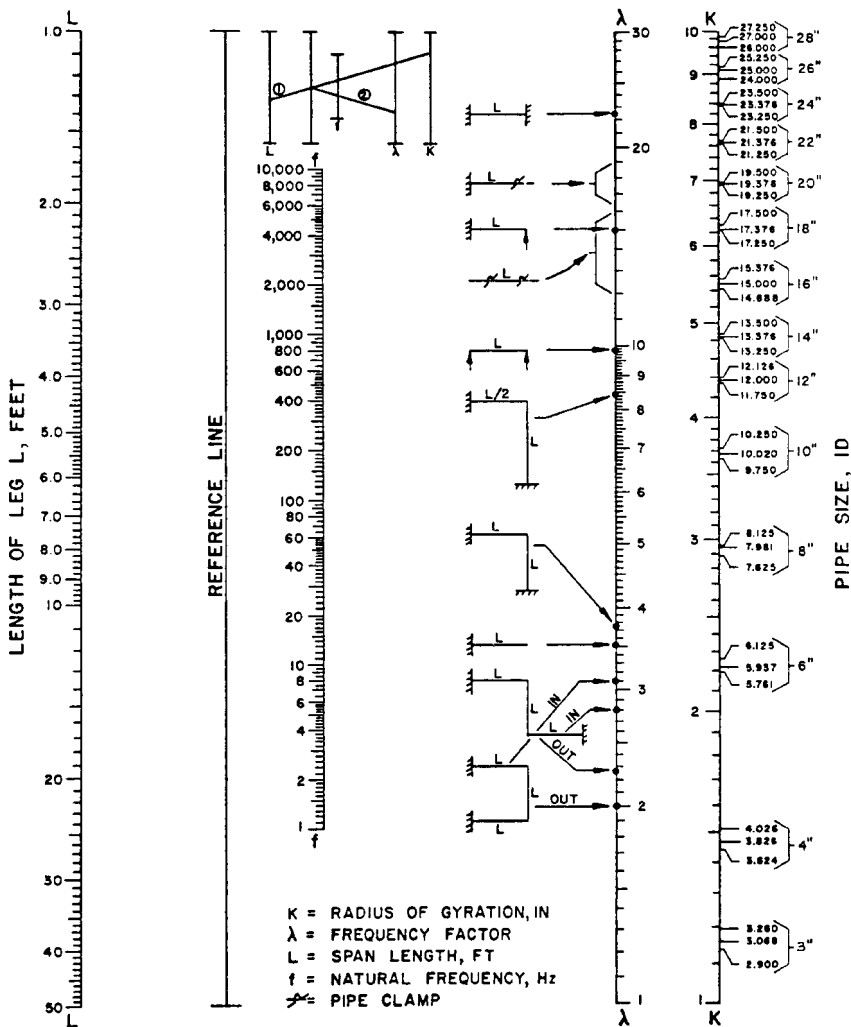


FIGURE 8 Natural frequency of uniform steel piping spans (1 ft = 0.3048 m; 1 in = 2.54 cm)

Accelerometers with low frequency characteristics may be used with electronic integrators to obtain accurate vibration displacement data from the pump case, cylinders, or piping. Similarly, velocity or seismic pickups may be employed. Maximum vibrations usually occur at the middle of piping spans and at unsupported elbows (out of plane).

Real-time analyzers and oscilloscopes may be used to display the resulting signals. A field example showing the diagnosis of cavitation at the pump suction using a strain gage diaphragm pressure transducer is given in the oscilloscope trace of Figure 9. The vapor pressure (gage) for this system was 25 lb/in<sup>2</sup> (172 kPa). Note that the negative half of the cycle is flattened when vapor pressure is reached and that very high amplitude pressure spikes are apparent. For liquids with dissolved gases, lower pulsation amplitudes can produce cavitation; however, the cavitation is usually less severe.

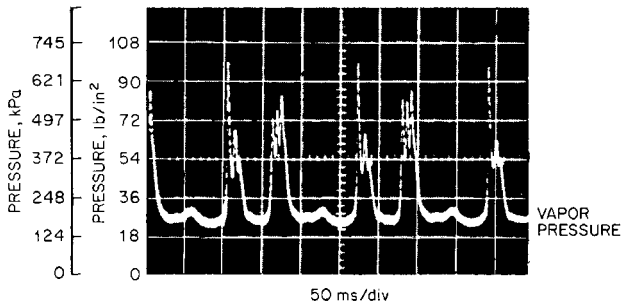


FIGURE 9 Complex wave data showing cavitation effects of pressure wave in a liquid piping system

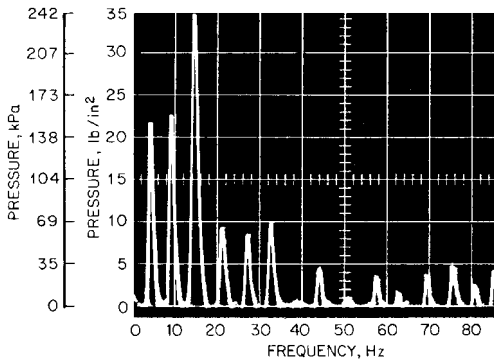


FIGURE 10 Typical field data recorded on a three-plunger pump

Typical field pulsation data obtained on a three-plunger pump is shown in Figure 10, which is a frequency spectrum of the pulsations made by a real-time analyzer. Each spike represents a frequency multiple of running speed. Note that the third spike, representing the plunger frequency, has the largest amplitude; however, the components at one and two times pump speed are also significant, which means that these frequency components should be considered for pulsation control.

The vibration frequencies of the piping should be compared with pulsation frequencies to evaluate potential pulsation excitation of mechanical resonances. A check of the piping mechanical natural frequencies from the nomogram (refer to Figure 8) should be made to evaluate the possibility of a mechanical resonance. High vibrations produced by low-level pulsations at a particular frequency are indicative of a mechanical resonance, which can usually be corrected by additional piping restraints or snubbers. After the causes of the pulsations and vibrations are diagnosed, the techniques presented previously can be used to develop solutions.

**Thermal Problems** In pump systems with high thermal gradients, large forces and moments on the pump case can cause misalignment of the pump and its driver as well as pump case distortion resulting in vibrations, rubbing (wear), bearing failure, seal leakage, and so on. High stresses can be imposed on the piping, resulting in local yielding or damage to the piping restraints, snubbers, or support system. Misalignment problems commonly exhibit a high second-order component of the shaft vibrations. Proximity

probes can be used at the bearings to measure movement of the shaft relative to the bearing centerline.

**Diagnosis of Shaft Failures** Pump and driver shafting can experience high stresses during start-up and normal operation because of the uneven torque loading of the positive displacement pumping action. Shaft failures are strongly influenced by the torsional resonances of the system, which are the angular natural frequencies of the system.

Torsional vibrations can be measured using velocity-type torsional transducers that mount on a stub shaft. Alternatively, they may be gauged by measuring the gear tooth passing frequency with a magnetic transducer or proximity probe and using frequency-to-voltage converters to give the change in tooth passing frequency (the torsional vibrational velocity). Spectral analysis of these signals defines the torsional amplitudes and natural frequencies. The stresses can be calculated by using the mode shape of the specific resonant natural frequency and combining all the torsional loads. Torsional natural frequencies, mode shapes, and stresses can be calculated by using either the Holzer technique or digital computer programs.<sup>12</sup>

Torsional problems can usually be solved by changing the coupling stiffness between the driver and pump or by using a flywheel in an effective location. The addition of a flywheel will tend to smooth the torque oscillations. Pumps with a greater number of cylinders and equal cylinder phasing usually operate more smoothly with lower shaft stresses.

## REFERENCES

---

1. Von Nimitz, W. W. "Reliability and Performance Assurance in the Design of Reciprocating Compressor and Pump Installation." 1974 Purdue Compressor Technology Conference.
2. Sparks, C. R., and Wachel, J. C. "Pulsation in Centrifugal Pump and Piping Systems." *Hydrocarbon Processing*, July 1977, p. 183.
3. Hayward, A. T. J. "How to Estimate the Bulk Modulus of Hydraulic Fluids." *Hydraulic Pneumatic Power*, Jan. 1970, p. 28.
4. Wright, W. A. "Prediction of Bulk Moduli and Pressure-Volume-Temperature Data for Petroleum Oils." *ASLE Transactions* 10:349, 1967.
5. API Technical Data Book, *Petroleum Refining*, 2nd ed., Washington, D.C., 1972.
6. Klaus, E. E., and O'Brien, J. A. "Precise Measurement and Prediction of Bulk-Modulus Values for Fluids and Lubricants." *Journal of Basic Engineering*, September 1964, p. 469.
7. Noonan, J. W. "Ultrasonic Determination of the Bulk Modulus of Hydraulic Fluids." *Materials Research and Standards*, December 1965, p. 615.
8. Hicks, E. J., and Grant, T. R. "Acoustic Filter Controls Reciprocating Pump Pulsations." *Oil and Gas Journal*, January 15, 1979, p. 67.
9. American National Standard for Reciprocating Power Pumps for Nomenclature, Definitions, Application and Operation, ANSI/HI 6.1-6.5-2000, Hydraulic Institute, Parsippany, NJ [www.pumps.org](http://www.pumps.org).
10. *Machine Design*, Fluid Power Reference Issue, vol. 52, no. 21, Penton Publications, Cleveland, 1980.
11. Wachel, J. C., and Bates, C. L. "Techniques for Controlling Piping Vibration and Failures." ASME paper 76-Pet-18, 1976.
12. Szenasi, F. R., and Blodgett, L. E. "Isolation of Torsional Vibrations in Rotating Machinery." *Proceedings of the National Conference on Power Transmission*, vol. II, Illinois Institute of Technology, 1975.

**FURTHER READING**

---

Positive Displacement Pumps: Reciprocating, API Standard 674, 2nd ed., 1995, American Petroleum Institute, Washington, D.C., [www.api.org](http://www.api.org).

Positive Displacement Pumps: Controlled Volume, API Standard 675, 2nd ed., 1994, American Petroleum Institute, Washington, D.C., [www.api.org](http://www.api.org).

---

# SECTION 3.5

---

# DISPLACEMENT PUMP FLOW CONTROL

---

WILL SMITH

## **FLOW CONTROL IN INDIVIDUAL PUMPS**

---

An inherent characteristic of positive displacement pumping of relatively incompressible liquids is that flow rate is proportional to displacement rate and independent of pressure levels. The capacity of a centrifugal pump operating at constant speed varies from a maximum flow at no developed pressure to zero flow at a definite limiting pressure known as shutoff head. The *average* capacity of positive displacement pumps at constant speed is, within design limits of pressure, practically constant, even though flow rate pulsations do occur as individual displacements are forced into the discharge pipe.

Flow control of positive displacement pumps is accomplished by

- Changing the displacement rate
- Changing the displacement volume
- Changing the proportion of the displacement delivered into the piping system

**Throttle Control in Direct-Acting Steam Pumps** Direct-acting pumps are controlled by speed change, which is effected by throttling the flow of steam (or other motive gas) to the drive cylinder. The magnitude of excess force on the drive piston over that required for the driven, or pumping, piston to force pumpage into the piping system dictates the stroke rate and therefore the capacity of the pump. A sensor that detects the desired result of pumping (pressure, level, flow rate, and so on) may be used to modulate the steam throttle valve.

**Speed Control in Power-Driven Pumps** Speed modulation is the most common means of flow control for power-driven pumps. The most rudimentary speed control is intermittent (start-stop) operation. The average capacity over relatively long time periods depends upon the percentage of time the pump operates at 100% versus the percentage of time it

operates at zero flow. Of course, consideration must be given to the frequency of starts because electric motors may overheat if there is insufficient time for cooling after the inrush of starting current.

When continuous modulation of flow is desired, means of varying the driver speed or the ratio of speed reduction between the driver and pump are employed.

#### DRIVER SPEED CONTROL

1. Multispeed constant-torque motors offer limited steps in speeds.
2. Variable-frequency motor controls permit a wide range of fully modulated speeds but, at present, are limited in maximum horsepower (Subsection 6.2.2).
3. Direct current and wound rotor alternating current motors permit modulation of speeds within definite limits of torque capability (Subsection 6.2.2).
4. Gasoline and diesel engines provides speed variation capabilities within the limits where driver torque is adequate to satisfy the constant-torque requirements of the pump (Subsection 6.1.3).
5. Steam or gas turbines can operate over a limited speed range within their particular output torque limits (Subsections 6.1.2 and 6.1.5).

**SPEED CHANGER CONTROL** Because *most* positive displacement pumps operate at significantly lower speed than *most* drivers, a speed reduction unit is coupled between driver and pump. Capacity control by varying the ratio of the speed reduction is quite convenient. A number of methods are used.

1. *Variable-ratio belt drives* change the speed by changing the pitch diameter of driver and driven sheaves in response to capacity requirements (Subsection 6.2.5).
2. *Hydraulic torque converters* (hydrodynamic drives) vary the speed by regulating the amount of active drive fluid in the coupling. Because these converters relate torque to speed, they are sensitive to the driven torque requirement change that may derive from system pressure changes (Subsection 6.2.3).
3. *Hydroviscous drives* vary the slip between input and output shafts by adjusting the distance between elements in a viscous fluid environment (Subsection 6.2.3).
4. *Eddy-current couplings* also vary the slip between driver and driven elements but do so by varying the strength of a magnetic field (Subsection 6.2.1).

**Variable Displacement Flow Control** Rather than by speed control (changes in the number of displacements in a given period of time), flow may be varied by changing the volume displaced per stroke.

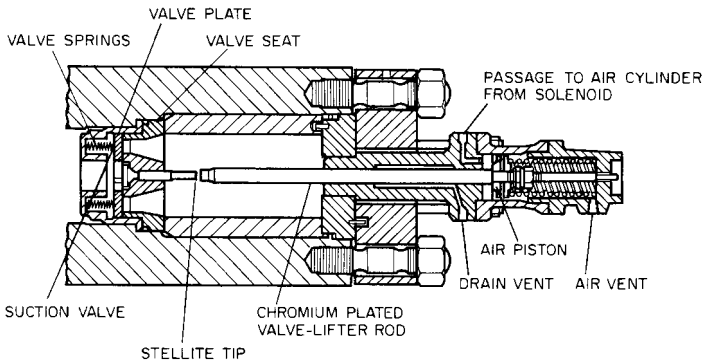
Variable strokes are generally limited to small metering or “controlled volume” pumps. Although large-capacity variable-stroke pumps have been built, the complexity of the mechanism involved and the development of other effective and economical means of flow control have precluded their use (Subsection 9.16).

**Changing Delivery to the System** Another means of capacity control is *not* to vary the pump capacity but to alter the amount of pumpage delivered to the system. There are two popular means of doing this.

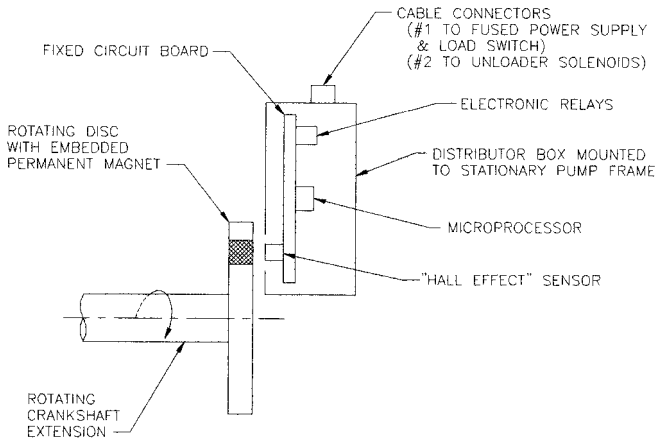
**SUCTION VALVE UNLOADING** Suction valve unloaders cause the displacement to be ineffective during the strokes for which the unloaders are activated. They command either full or zero delivery while the pump is kept running. Thus, current inrush problems from frequent motor starts are avoided. Because discharge pressure is not developed when suction valves are unloaded, energy consumption is held to a minimum.

A pump valve is unloaded by mechanically preventing the valve plate from returning to its seat. If the suction valve is held away from its seat, liquid will ebb and flow through the valve from suction header to pump cylinder and from cylinder to header during the stroking of the plunger or piston.





**FIGURE 1** Synchronized unloading keeps the valve open through the use of a suction valve unloader.



**FIGURE 2** "Hall effect" microprocessor distributor system.

The unloader mechanism does not move the valve. The valve is lifted off its seat by the pressure differential created by normal pump operation. In synchronized unloading, the suction valve unloader (Figure 1) is retracted only when it is certain that the incoming flow will keep the valve open.

The unloader never resists pressure in the cylinder; it merely holds the valve plate against valve springs that had already been compressed and moves away from the valve while the springs are still compressed. This permits the valve to close when the plunger begins its discharge stroke.

For smooth transition between full flow and zero flow, the unloading and loading are accomplished in an immediate and identical sequence of the pumping order of the plungers. It is the function of the synchronized suction valve unloader distributor (Figure 2) to control unloading events in that proper and immediate sequence. Similarity can be drawn to the gasoline engine distributor in its function of assuring the proper and immediate sequence of firing of the spark plugs.

The distributor is driven directly by the crankshaft so its position is positively indexed to the stroking of the plungers. It provides an electrical signal to a solenoid valve, which

admits motive fluid pressure to the unloader chamber when the suction valve to the particular cylinder has been opened. Then, in sequence, each of the remaining suction valves is retained so, in the first revolution of the pump after a control signals the distributor to initiate unloading, all suction valves are unloaded and the pump capacity is reduced to zero. When the control again signals for capacity, each suction valve is released, in sequence, during a single revolution of the crank.

While unloaded, the discharge valves do not function; they remain closed and serve as check valves against the pressurized discharge system. The suction valves remain open. Liquid enters from and is dispelled back into the suction manifold through the open suction valves. Therefore, no work is applied to the liquid, not even that required to open the suction and discharge valves. When the control calls for loading, the load is applied in steps equal to the number of plungers. Thus the pumping horsepower, as well as the liquid inertia in the pumping system, is changed in a number of steps equal to the number of plungers over the time span of one crank revolution.

The unloader consists of a spring-loaded pneumatic cylinder attached to the suction valve cover. The spring advances holding fingers that keep the valve away from its seat. Pneumatic pressure, applied through a solenoid valve in response to the distributor signal, creates a force on a piston that opposes the spring force and allows the suction valve to load (close). The system is normally arranged to fail in the unloaded position on either electrical or pneumatic pressure failure.

Distributor systems have evolved from a) direct mechanical linkages between reciprocating parts and the suction valves, to b) electromechanical interfacing, to c) electronic proximity systems, to d) a "Hall effect" sensor signaling a microprocessor. The objective of each of these systems is to cause suction valve unloader solenoids to activate or de-activate in the appropriate sequence and at the appropriate position of the plunger during the suction stroke.

**BYPASS CONTROL** Ultimate delivery of pumpage to the system may be controlled by a discharge-to-suction bypass valve. Pump operation is continuous, with the possibility of modulating the flow to the system by regulating the portion "bypassed" to suction. A serious disadvantage is the full power utilization and full-load wear and tear even when at zero system capacity.

**Evaluation of Flow Control Options** Proper selection of the means of capacity control requires consideration of system control requirements and then evaluation of the options available to satisfy those requirements.

Precision, responsiveness, and degree of modulation required may limit options. First cost, maintenance requirements, and the effect on pump operating cost should then be weighed for viable options. To evaluate the effect of operating costs, it is necessary to determine (or reasonably assume) the expected pattern of operation throughout the capacity range. For example, if practically all operation except infrequent start-ups is to be at full pump capacity, little penalty should be assigned to the full power usage of a bypass valve or to the part-load losses inherent with hydroviscous or eddy-current drives.

If smooth modulation of flow is not essential, start-stop or suction valve unloading may be the preference. If smooth modulation and considerable operation at part capacity are necessary, variable-frequency motors or variable-pitch V-belt drives may be indicated.

Table 1 and Figure 3 provide some general guidelines. Each application should be evaluated on the merits of requirements and options.

### **FLOW CONTROL IN COMBINED DISPLACEMENT AND CENTRIFUGAL PUMPS**

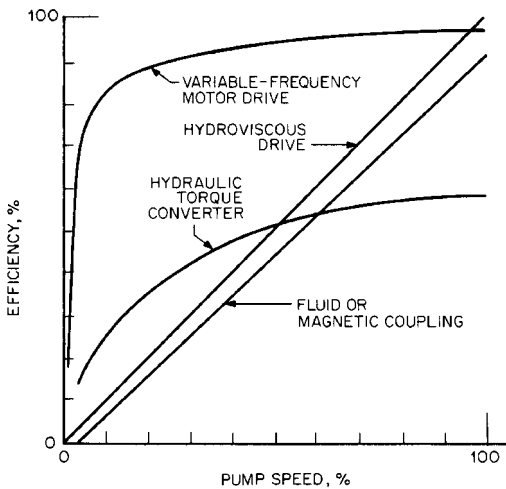
Systems that involve both centrifugal and reciprocating positive displacement pumps deserve some special consideration. Centrifugal pumps are often used as suction boosters to overcome acceleration head requirements peculiar to reciprocating pumps but are rarely used to supplement flow. Some unique characteristics of each type of pump that affect the other type must be considered in the design, operation, and control or the inter-related system.

**TABLE 1** Comparison of several capacity control schemes for positive displacement pumps

Control Method	Degree of Modulation	First Cost	Operating Cost	Comments
<i>Directing-acting pumps</i>				
Steam throttle	Full: zero to 100%	Low	Low	Steam pressure required to balance liquid piston force and overcome breakaway friction. Steam volume throttled to produce desired capacity.
<i>Power pumps</i>				
Start-stop	Zero or 100%	Low	Low	Limited in frequency of starts because of temperature rise from inrush.
Multispeed motors	Steps dependent on motor winding	Medium	Low	Cost of motor controller switch gear motors must be assessed.
Variable frequency	Full: zero to 100% +	High	Low	Limited by current-handling capacity of solid-state controller.
Direct current	Full: zero to 100%	High	Medium	Drive is torque-speed sensitive, pump is torque-pressure sensitive at all speeds. Check drive for required torque at minimum and maximum speeds.
Wound rotor motors	Full: zero to 100%	High	Low	Drive is torque-speed sensitive. Pump is torque-pressure sensitive at all speeds. Check drive for required torque at minimum and maximum speeds.
Combustion engines	Variable for limited range	High	Low	Torsional analysis required to avoid high torsional stresses.
Steam or gas turbines	Variable for limited range	Medium	Medium	Drive is torque-speed sensitive. Pump is torque-pressure sensitive at all speeds. Check drive for required torque at minimum and maximum speeds.
Hydraulic torque converter	Full: zero to 100%	High	High	Low full speed efficiency.

**TABLE 1** Comparison of several capacity control schemes for positive displacement pumps (*Continued*)

Control Method	Degree of Modulation	First Cost	Operating Cost	Comments
<i>Power pumps</i>				
Hydroviscous speed control	Full: zero to 100%	High	High at part load	Efficiency proportional to capacity. Loss to heat exchanger.
Fluid coupling	Full: zero to 100%	Medium	High	Full-speed slip loss greater than hydroviscous. Loss to heat exchanger.
Magnetic (eddy) coupling	Full: zero to 100%	High	High	Full-speed slip loss.
Suction valve unloaders	Zero or 100%	Low	Low	Synchronization with suction stroke avoids start-stop and shock problems.
Bypass valve	Limited	Low	High	Uses full power at zero capacity with full valve wear.
Variable-pitch belt	Limited	Low	Low	Limited to belt drive horsepower.

**FIGURE 3** Relative efficiencies of speed control options.

### ***Pertinent Positive Displacement Pump Characteristics***

1. The discharge pressure produced is a function of the system requirement only and is independent of pump capacity.
2. The flow rate pulses between maximum and minimum values for each revolution of the crankshaft.

3. The pulsating flow imposes an acceleration head that adds to the net positive inlet pressure required (Section 3.1).
4. Being more energy-efficient, the positive displacement pump is normally the lead pump and the centrifugal pump is the supplement when operated in parallel.

### **Pertinent Centrifugal Pump Characteristics**

1. The dynamic head (or pressure rise) produced is a function of pump capacity as well as of system requirements.
2. For satisfactory operation, the flow must be kept within a limited range of the best efficiency capacity (Subsection 2.3.1).
3. When used as a suction booster, the centrifugal pump must be designed so it cannot introduce air into the gas-intolerant reciprocating pump. (Gas in positive displacement pumps, like liquids in positive displacement compressors, may cause severe hydraulic and mechanical shock.)
4. Centrifugal pumps do not generate acceleration heads that impose on net positive suction head required. However, if a centrifugal pump is connected in parallel to a common suction line with a reciprocating pump, some of the system acceleration head loss from the positive displacement pump may affect the centrifugal pump.

Only two cases need to be considered: centrifugal pumps feeding (1) in series into reciprocating pumps to increase suction *NPSHA* to the reciprocating pump or (2) in parallel to augment the delivered capacity. It would be most unusual to encounter a positive displacement pump feeding into the suction of a centrifugal pump because of the high pressure that could be imposed on the centrifugal pump suction and because of the amplification of flow pulsations resulting from interaction of the characteristics of the two pumps, which could be deleterious to both pumps.

**Series Operation, Suction Boost** The flow rate is always determined by the positive displacement pump capacity and is independent of the centrifugal booster pump. The capacity is therefore controlled as with any positive displacement pump.

The purpose of the centrifugal pump is to supply sufficient pressure to satisfy the suction requirements of the positive displacement pump. The centrifugal pump must be sized to provide the maximum rate of flow of the positive displacement pump at a pressure high enough to meet the *NPSH* requirement of the latter.

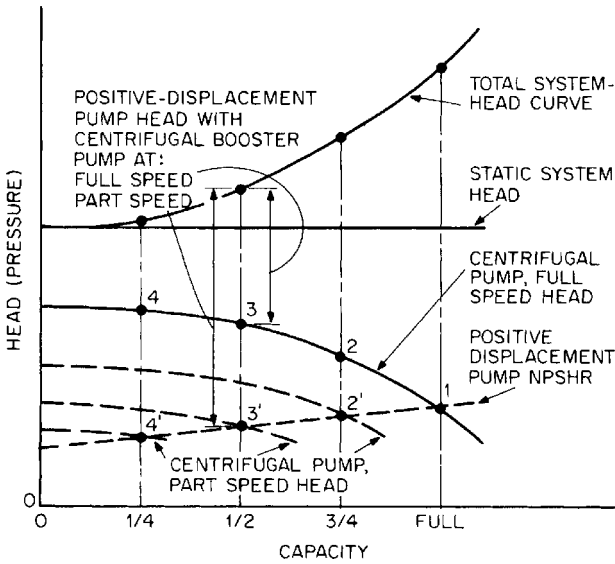
With a flow-controlled positive displacement pump, speed control of the booster might be considered, as illustrated in Figure 4. The system pressure requirement can be satisfied by the positive displacement pump at all flow rates; therefore, total energy requirements may be reduced by using the less efficient centrifugal pump to develop no more than the required suction head.

If the centrifugal booster pump is run at constant speed, its share of the total head requirement will increase as system capacity is reduced.

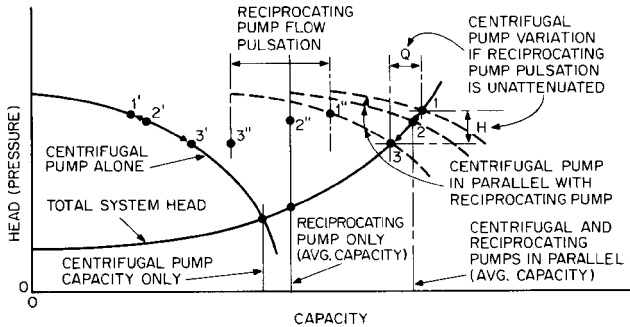
**Parallel Operation** To increase the capacity of an existing pumping system, it is sometimes convenient to consider paralleling a positive displacement pump with a centrifugal pump. The interactions of the two pumps and the system must be considered and controlled for satisfactory operation.

Suction stabilizers and discharge dampeners, desirable for most reciprocating pump installations, become mandatory when a centrifugal pump and a positive displacement pump are connected in parallel. These devices are used to isolate, as much as possible, the effects of positive displacement pump flow pulsations from the sensitive centrifugal pump operating characteristics.

Centrifugal pumps in parallel with positive displacement pumps can supplement the system capacity only while they generate sufficient discharge pressure to satisfy the system requirement at the higher total flow. Undampened flow pulsations shift the centrifugal shutoff flow point relative to system flow at the frequency of the reciprocating



**FIGURE 4** A centrifugal booster pump can satisfy the NPSH requirement of a positive displacement pump by operating either on its characteristic full speed curve 1-2-3-4 or with speed reduction along curve 1'-2'-3'-4'.



**FIGURE 5** Parallel operation of undamped reciprocating and centrifugal pumps.

1. The reciprocating pump will operate at a capacity corresponding to its speed regardless of its discharge pressure.
2. If the system head is only static (constant head), the centrifugal pump capacity is constant and the system flow variation corresponds to the reciprocating pump variation.
3. If the system head is partially dynamic (as illustrated), the centrifugal pump will experience flow variations.
  - a. The flatter the centrifugal pump curve, the greater the capacity and smaller the head variations on the centrifugal pump.
  - b. The flatter the system curve, the lower the capacity and greater the head variations on the centrifugal pump.

pulsation. From the system standpoint, the total flow varies along curve 1-2-3-2-1 in Figure 5. From the centrifugal pump standpoint, it varies along its characteristic curve, 1'-2'-3'-2'-1'. The reciprocating pump operates along curve 1''-2''-3''-2''-1''.

For purely static system-head curves, the centrifugal pump theoretically would not “sense” the pulsating flow. For dynamic system heads, the centrifugal pump flow varies

contracyclically with the reciprocating pump pulsations. The magnitude of the centrifugal pump flow variation due to the positive displacement pump pulsations is a function of the system head curve, the centrifugal pump head-capacity curve, the degree of flow pulse imposed on the centrifugal pump discharge header, and the liquid bulk modulus (or compressibility).

### ***FLOW CONTROL IN POSITIVE DISPLACEMENT PUMPS IN SERIES***

---

Whenever positive displacement pumps are installed in series (such as for multiple-station pipeline service), some variable-capacity capability is mandatory. Otherwise, any variation in capacity between series pumps or series groups of pumps would result in disastrous interstation pressures.

The flow is determined by the first pump in the line. Subsequent pumps should be equipped with capacity controls responsive to their inlet pressures. The preferred control is a continuous-modulation type, such as variable speed, unless large reservoir capacity is available between pumps.

Recirculation from discharge to suction through a throttling bypass valve may be used, at the expense of energy, to match the delivery from downstream pumps to upstream pumps. Excessive bypass flow in relation to through flow can result in significant temperature rise of the liquid.

When downstream pump capacity is less than the upstream delivery, the inter-pump pressure will rise, indicating a need for increased capacity. When the downstream pump capacity exceeds the upstream delivery, the downstream pump will “draw down” the inter-pump pressure to the point where net positive inlet pressure difficulties are ensured.

Reservoir accumulators between pumps permit a limited degree of mismatch in capacities, allowing the use of incremental capacity controls, such as suction valve unloading and intermittent pump bypass.

In any event, effective discharge dampeners on the upstream pump and suction stabilizers on the downstream pump are necessary to prevent the inherent pressure pulsations and control modulation variances from adversely affecting operation.

### ***FLOW CONTROL IN POSITIVE DISPLACEMENT PUMPS IN PARALLEL***

---

Because the capacity of positive displacement pumps is virtually independent of head, there is no problem from the head-capacity characteristics in parallel operation—even for pumps of different sizes.

Particular attention to suction acceleration head requirements is necessary when more than one pump is taking suction from a common suction pipe. Because it cannot be assured that two pumps will not, at some point, have simultaneous suction strokes, the acceleration head requirements of each pump must be added for that portion of the suction line that furnishes the total flow. This suggests extra large suction lines, individual ones from the liquid source, or suction stabilizers sized for the total flow with individual outlet connections for each pump.

---

# SECTION 3.6

---

# DIAPHRAGM PUMPS

---

STEPHEN D. ABLE  
ROBERT BEAN  
WARREN E. RUPP

Diaphragm pumps are a class of displacement pumps featuring flexible membranes in combination with check valves that are used to move fluids into and out of pumping chamber(s). These pumps are used extensively in transfer and metering applications requiring flows of up to 300 gallons per minute (1150 liters per minute). They are quite versatile, handling a wide variety of fluids including chemicals, dry powders, food additives, glues, paints, pharmaceutical products, slurries, tailings, and wastewater. A distinguishing feature of all diaphragm pumps is the absence of seals or packing, meaning they can be used in applications requiring zero leakage. There are three main categories of diaphragm pumps: 1) mechanically driven, 2) hydraulically driven, and 3) air-operated.

## **MECHANICALLY DRIVEN DIAPHRAGM PUMPS**

---

Many industries are served by mechanically driven diaphragms pumps. They are used in construction, chemical, and water treatment applications.

**Construction Industry** Mechanically driven diaphragm pumps are widely used in the construction industry for dewatering applications where pumps may ingest rocks or other debris. A popular make of this type of pump contains a spring on the plunger rod (see Figures 1 and 2). If the operating pressure exceeds the maximum recommended pumping pressure, the spring compresses and does not move the diaphragm. The spring can compress and thus keep a rock from being pushed through the wall of the pumping chamber or cause the drive mechanism to fail.

In single-diaphragm pumps, the pumped liquid can have a lot of inertia if the suction and discharge lines are relatively long. A simple accumulator on the suction (inlet) side of the pump enables the pump to draw liquid from the accumulator while it simultaneously draws liquid through the suction line.



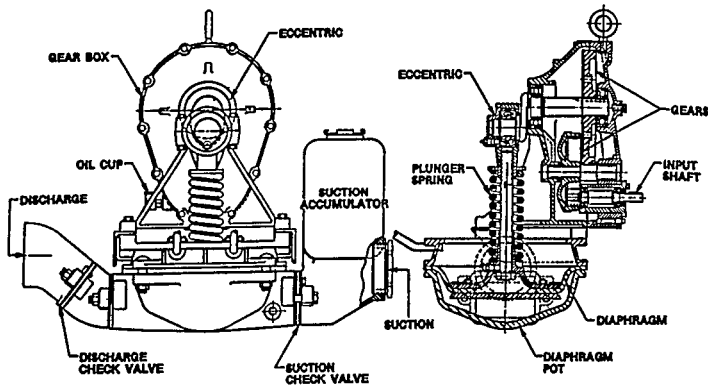


FIGURE 1 Cross-section of a mechanically driven single-diaphragm pump for the construction industry (Gorman-Rupp)

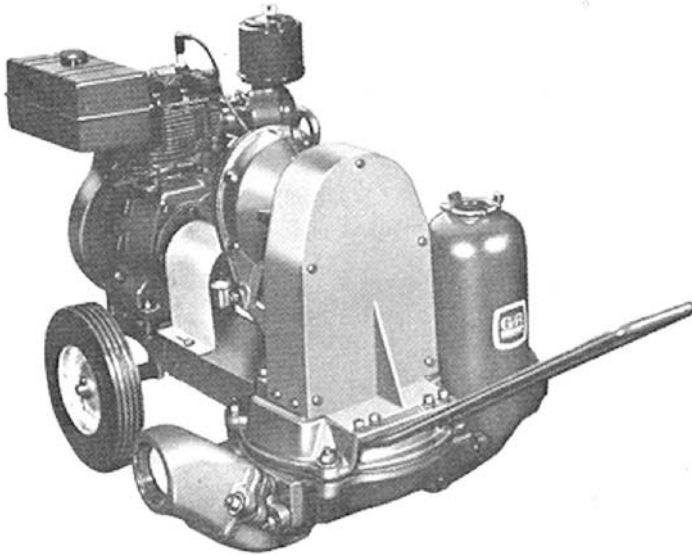


FIGURE 2 Mechanically driven single-diaphragm pump, engine-powered (Gorman-Rupp)

During the discharge stroke, the accumulator can refill with liquid from the suction line. If the discharge line from the pump is relatively long, the inertia of the liquid can be great, as mentioned earlier, and can impose severe loads on the diaphragm and drive mechanism. The spring on the plunger rod can absorb some of the drive energy early in the discharge stroke and “give it back” during the latter part of the discharge stroke, greatly reducing the inertia loading on the diaphragm and drive mechanism.

Mechanically driven diaphragm pumps in the construction industry operate by a reciprocating plunger, usually secured to plates on both sides of the diaphragm. The diaphragms are customarily fabric-reinforced elastomers (usually synthetic rubbers) similar in many ways to the fabric-reinforced materials used in pneumatic tires. The diaphragms are normally molded with a convoluted section between the central clamped area and the clamped periphery. This convoluted section permits longer strokes than would be possible otherwise.

These pumps are sometimes duplexed so that the reciprocating means acts alternately on two diaphragms with one on a suction stroke, while the other is on a discharge stroke and vice versa. A connector called a *walking beam* is pivoted between two diaphragms. As one diaphragm is pushed down on a discharge stroke, the other diaphragm is simultaneously pulled up on a suction stroke. The pumping chambers with inlet and outlet check valves are manifolded together to a common inlet and a common outlet. The principle advantage of the duplex diaphragm pump is its more constant flow (two pressure pulsations per cycle).

Mechanically driven diaphragm pumps are used in the construction industry for dewatering foundations and cofferdams, as well as in sewage treatment plants for pumping lime slurries. They are normally limited to 50 ft (15.2 m) of differential head and are capable of suction lifts of as much as 25 ft (7.6 m).

**Chemical and Water Treatment Industries** Another type of mechanically driven diaphragm pump is used for the injection or transfer of chemicals into process streams at pressures up to 250 lb/in<sup>2</sup> (17 bar). These pumps are designed to enable the easy adjustment of their capacities, so precise volumes of chemicals can be injected. Typically, capacities can be adjusted through a 20:1 range. Injection repeatability is generally plus or minus 3%.

A wide range of chemicals can be handled. Wetted materials include PVC, PVDF, Polypropylene, 316SS, Alloy 20, and Alloy C22. Diaphragms are PTFE or PTFE with elastomeric backing. Ball type check valves are usually employed.

Applications for this type of pump include the injection of acids and bases for pH control, biocides, chlorination, coagulants, and fertilizers. There are two basic configurations for pumps in this class: *electromagnetic pumps* (solenoid) and *motor-driven pumps*.

Electromagnetic (electronic) pumps (see Figure 3) are used in a variety of low-power applications with flows from 0.026 to 26 gallons per hour (0.1 to 100 liters per hour) at pressures up to 250 lb/in<sup>2</sup> (17 bar). These metering pumps employ an electronic control circuit that pulses an electromagnet that, in turn, generates the linear motion of an armature-shaft-diaphragm assembly. Each electronic pulse results in one discharge stroke of the pump. At the end of the stroke, a set of springs returns the diaphragm assembly to its initial position, drawing more fluid into the pump chamber in preparation for the next stroke.

These pumps are inherently safe, as they can be run indefinitely in the stalled condition without damage to the pump or overpressuring most systems. An additional feature of certain electronic pumps is the regulation of pulse strength through electronic power control, which leads to smoother fluid injection. Capacity is usually controlled by adjust-

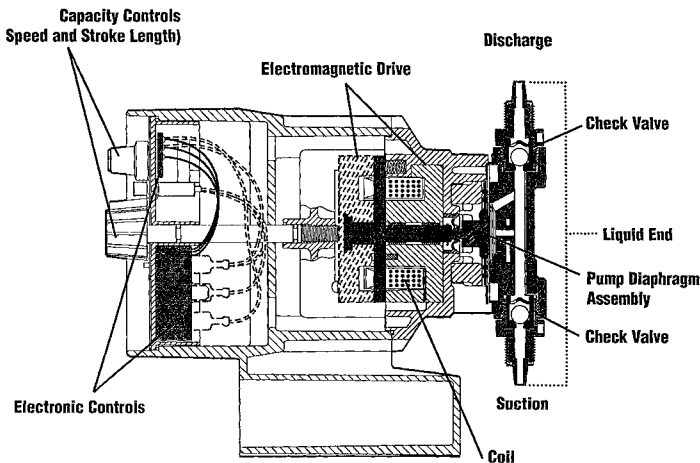


FIGURE 3 Electromagnetic diaphragm pump (Milton-Roy, subsidiary of Sundstrand Corp.)

ing the stroke rate, but the stroke length can also be adjusted. Combining these adjustments provides a wide range of outputs.

Advances in the electronic controls have led to the capability to control output manually from 4–20 mA process signals, digital pulses from external sources (such as flow meters), or serial data communications signals from computers. Yearly maintenance is recommended for low-pressure applications, but as pressures rise, diaphragms and check valves will need to be replaced more frequently.

Motor-driven, mechanically actuated diaphragm pumps are used in applications for flows from 2 to 300 gallons per hour (approximately 10 to 1000 liters per hour) again at pressures up to 250 lb/in<sup>2</sup> (17 bars). Since motor-driven, mechanically actuated diaphragm pumps are positive displacement pumps, capacities cannot be adjusted by the use of a throttling valve.

Three techniques are used in the industry to adjust motor-driven pump capacities. Some designs employ the use of a “mechanical lost motion” mechanism in which an adjustable mechanical stop interrupts the spring-loaded crosshead from following the cam for a portion of the stroke. This decreases the effective stroke length (see Figure 4). Other designs employ the use of an adjustable crank machined with a “variable eccentricity.” The adjustment of the crank’s position changes the pump’s effective stroke length (see Figure 5). The third design technique is the use of AC or DC variable speed motors.

At higher flow rates, attention should be paid to the system design to ensure the proper handling of pressure pulsations, due to the acceleration and deceleration of the process fluid in the lines. This is especially true for pumps having a mechanical lost motion configuration, due to the diaphragm’s rapid starts and stops. In the higher flow systems, pulsation dampeners are frequently employed in the discharge lines and occasionally need to be used in the suction lines to control pulsations. When discharge pressures are low, backpressure valves are employed to provide a system pressure sufficient to decelerate the fluid in the suction line at the end of every suction stroke. If the flow of the process fluid in the suction line has not stopped by the beginning of the discharge stroke, the accuracy of the injection is diminished. Yearly maintenance is recommended for low-pressure applications, but as pressures rise, diaphragms and check valves will need to be replaced more frequently.

**Other Mechanically Driven Diaphragm Pumps** Automotive fuel pumps are usually of the diaphragm type. The diaphragm is moved mechanically by a cam on a suction stroke

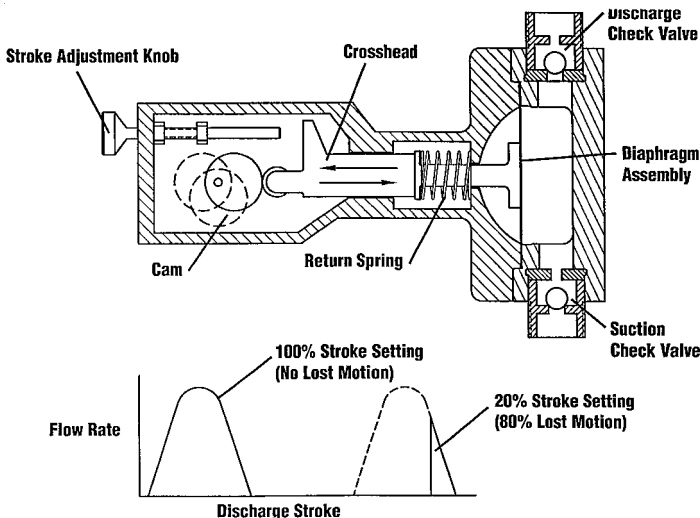
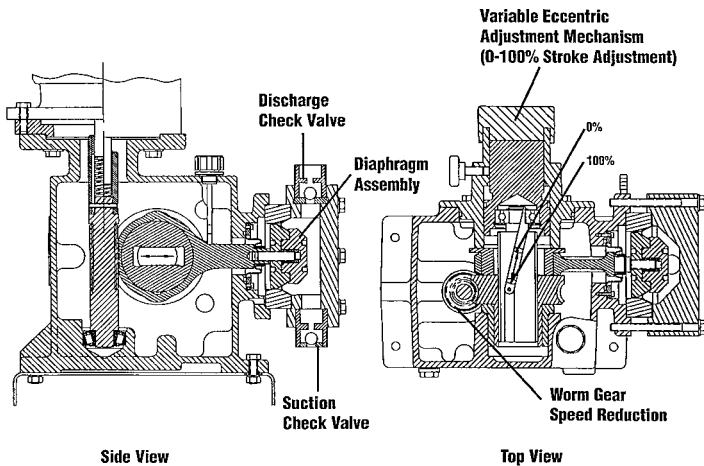


FIGURE 4 Diaphragm of a typical mechanical lost motion mechanism (Milton-Roy, subsidiary of Sundstrand Corp.)



**FIGURE 5** Cross-section of a variable eccentric mechanically driven diaphragm pump (Milton-Roy, subsidiary of Sundstrand Corp.)

and is returned by a spring for the discharge stroke. Thus, the spring determines the discharge pressure and provides a nearly constant pump pressure to the carburetor regardless of the pump (engine) speed or the rate of fuel consumption. Hand-operated diaphragm pumps are used extensively as bilge pumps on sailboats where the loss of power is a major concern and hand operation is essential.

### HYDRAULICALLY DRIVEN DIAPHRAGM PUMPS

Hydraulically driven diaphragm pumps are used in applications for the transfer or injection of chemicals into process streams at pressures up to 7500 lb/in<sup>2</sup> (approximately 500 bar). Because the diaphragm is pressure-balanced, the stresses in the diaphragms are low. Therefore, these pumps tend to require minimal maintenance. The pump's capacities can be adjusted to match the specific process requirement by adjusting the effective stroke length or stroking speed of the pump. Effective stroke lengths are adjusted by either a hydraulic lost motion, a mechanical lost motion, or by varying the eccentric's offset. The repeatability of the injected flow is plus or minus 1% or better.

Applications range from 0.26 to 26,000 gallons per hour (1 to 100,000 liters per hour). At flows above 26 gallons per hour (100 liters per hour), most pump models employ capacity adjustments based on variable eccentric or variable speed technology to avoid significant pressure spikes due to the rapid acceleration and deceleration of the fluid in the pipes.

As with the mechanical diaphragm pumps, a wide range of chemicals can be handled. Wetted materials include PVC, Polypropylene, PVDF, 316 SS, Alloy 20, Alloy C-22, Titanium, and Inconel. Diaphragms for pressures up to 4350 lb/in<sup>2</sup> (300 bar) are typically composed of PTFE or PTFE with an elastomeric backing. Diaphragms above 4350 lb/in<sup>2</sup> (300 bar) are typically 316 SS, Alloy C, or PEEK. Optional features include fluid temperature control jackets, diaphragm rupture detection capabilities, and remote diaphragm head designs. Typical applications include the injection of acids and bases for pH control, corrosion inhibitors, methanol, coagulants, primary process blending, process slurries, and drag reducers. Three types of liquid ends are used: the disc diaphragm, shown in Figure 6, the tubular diaphragm in Figure 7, and the high performance diaphragm in Figure 8.

The disc diaphragm pump is equipped with process-side and suction-side restraining plates to prevent overdisplacement of the diaphragm during system upsets. When the

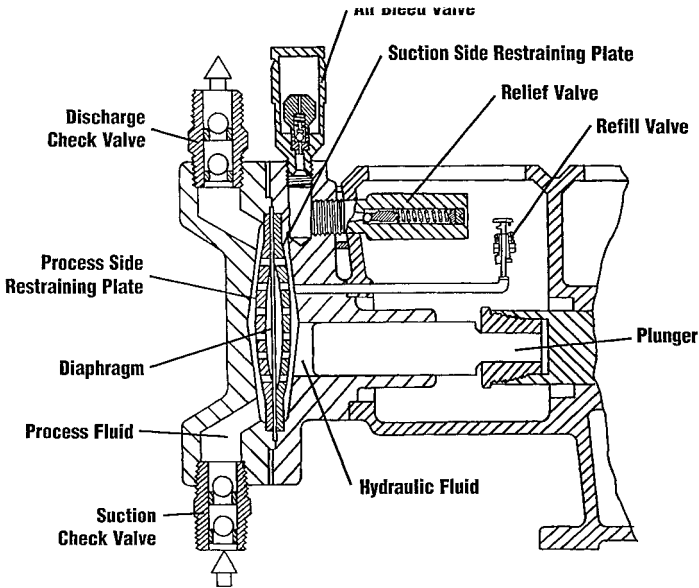


FIGURE 6 Diagram of a disc diaphragm pump (Milton-Roy, subsidiary of Sundstrand Corp.)

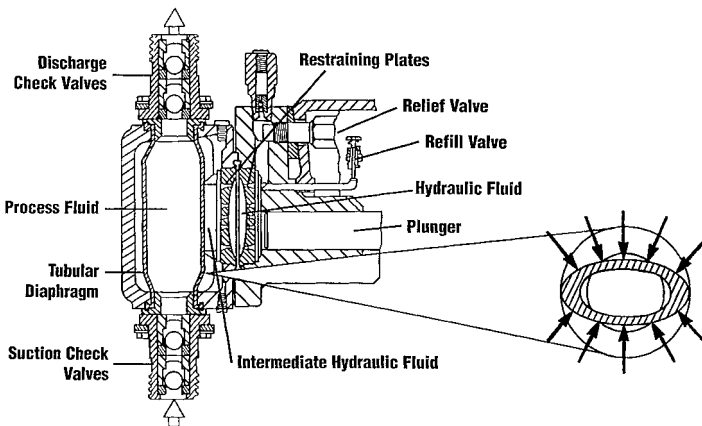


FIGURE 7 Diagram of a tubular diaphragm configuration (Milton-Roy, subsidiary of Sundstrand Corp.)

diaphragm reaches the suction-side restraining plate, the hydraulic oil pressure drops, causing the refill valve to open and replenish the oil. When the diaphragm hits the process-side restraining plate, the hydraulic pressure rises, causing the relief valve to open, venting some oil. The fluid volume between the restraining plates is typically 150% of the maximum displaced volume of the pump. Therefore, the diaphragm does not contact both restraining plates during the same stroke.

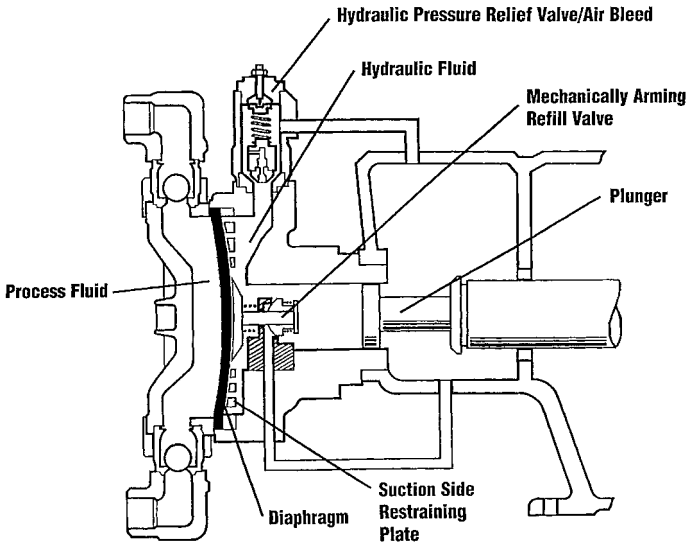


FIGURE 8 Diagram of a high performance diaphragm design (Milton-Roy, subsidiary of Sundstrand Corp.)

The tubular diaphragm configuration is a variation of the disc diaphragm design. A diaphragm shaped in the form of a tube is placed in a chamber in front of the disc diaphragm assembly. This design eliminates the process fluid flowing through the front-restraining plate, reducing viscous losses and wear in case of slurries. The chamber must be filled with a precise amount of hydraulic fluid to avoid overdisplacing the tube.

The high-performance diaphragm configuration eliminates the use of a process-side restraining plate providing the throughflow performance of a tubular design while eliminating the possibility of overdisplacing the tube during startup and maintenance. With a mechanically arming, pressure-sensitive refill valve, the hydraulic fluid can only be replenished when the diaphragm is in the most rearward position. This eliminates the possibility of overfilling the hydraulic chamber and therefore overdisplacing the diaphragm during system upsets (blocked suction or discharge lines).

Most problems with hydraulic diaphragm pumps occur due to incorrect system designs. Pressures above 9 lb/in<sup>2</sup> (0.6 bar) should be maintained in the pump diaphragm heads during the suction stroke to stop vapor buildups in the hydraulic or process-side cavities. Pressures at 3 lb/in<sup>2</sup> (0.2 bar) can be handled in some applications with modified designs and special hydraulic fluids. *NPSH* calculations should include viscous losses in the check valves and contour plates (if so equipped).

In addition, since hydraulic diaphragm pumps are reciprocating machines, acceleration losses also have to be considered. Peak acceleration/deceleration losses occur at the beginning and end of the stroke, while peak viscous losses occur at midstroke. The losses are not additive. The manufacturer should be contacted to provide guidance in performing these calculations.

As with mechanically driven diaphragm pumps, at higher flows, pulsation dampeners should be considered to ensure the proper handling of pressure pulsations due to the acceleration and deceleration of the process fluid in the lines. This is especially true for pumps having a mechanical lost motion configuration due to the diaphragm's rapid starts and stops. When discharge pressures are low, backpressure valves are employed to provide a system pressure sufficient to decelerate the fluid in the suction line at the end of every suction stroke. If the flow of the process fluid in the suction line has not stopped by the beginning of the discharge stroke, the accuracy of the injection is compromised.

### AIR-OPERATED DIAPHRAGM PUMPS (AODPS)

---

In general, diaphragm pumps of all types are sealless, have no dynamic seals or packing, are self-priming, and have an infinitely variable flow rate and pressure rate within the pressure and capacity ranges of the pump. *Air-operated diaphragm pumps* (AODPs) can also run dry indefinitely, and the discharge can be throttled to zero flow indefinitely.

The most common types of AODPs are the double-diaphragm pumps (duplex pumps). These contain two diaphragm chambers and two flexible diaphragms. The diaphragms are connected to each other through a connecting rod and are clamped at the outer edges of the diaphragm. The shaft-connected diaphragms move in the same linear direction simultaneously. Compressed air directed to the back side of the left diaphragm moves both diaphragms to the left, while air is exhausted to the atmosphere from the back side of the right diaphragm. After completion of a stroke, an air distribution valve directs compressed air from the supply to the back side of the right diaphragm and exhausts air to the atmosphere from the left chamber. This continuous reciprocating motion, along with properly operating internal check valves, creates an alternating intake and discharge of pumped liquid into and out of each chamber that results in a nearly continuous pumping action from the combined chambers.

A diaphragm pump air motor contains an air distribution valve that shifts positions at the end of each stroke of the pump. The air distribution valve alternately directs supply air pressure to one chamber and exhausts the other. Air motors often use a two-stage valve to control the reciprocating motion of the pump (see Figure 11). The pilot valve supplies a pilot air pressure signal to the air distribution valve throughout the entire stroke of the pump, even though pressure oscillations in the pumping system may occur. The pilot valve is not connected directly to the diaphragm's connecting rod, which provides a "deadband" to prevent the power valve from erroneously shifting just after the end of each stroke. The two views contained in Figure 11 depict the position of the moving parts just before the pilot valve is moved by its contact with the diaphragm washer. Depending on its position, the pilot rod alternately pressurizes and exhausts the large end of the air distribution valve. Other valve design configurations pressurize and exhaust both ends of the air distribution valve.

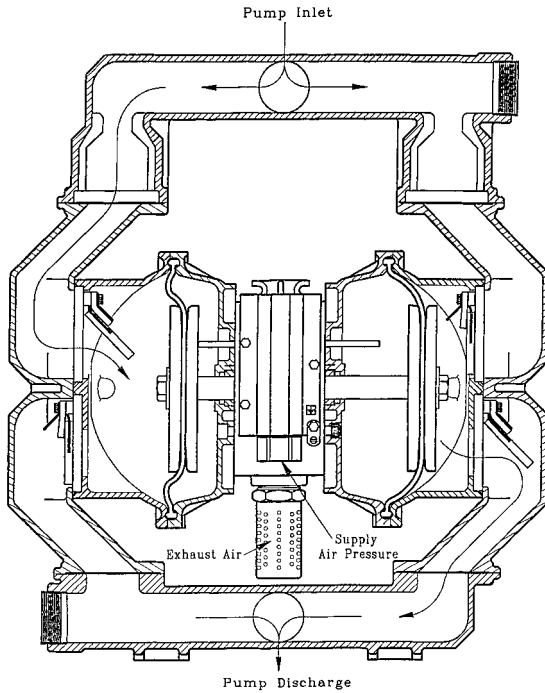
The two common types of liquid check valves that are used in a diaphragm pump are the *flap valve* and the *ball valve*. A flap valve pump (see Figures 9 and 10) can handle nearly marble-sized solids. Because the discharge is from the bottom of the diaphragm chambers, the pump is ideally suited for pumping solids in suspension that may tend to settle out, particularly when the pumping rate is reduced or when the pump is shut down. The bottom outlet enables foreign matter to be easily pumped out of the chambers.

The popular air-operated, double-diaphragm pump with ball valves (see Figures 12 and 13) features the inlet at the bottom of the diaphragm chambers, and the outlet is at the top. The top discharge arrangement has the advantage of enabling air or vapors to be easily expelled from the chambers. Trapped air or vapors in pumps having bottom outlets can reduce the volumetric displacement of the pumps as the air or vapor is alternately compressed and expanded, instead of the liquid being displaced. This can be a concern in low-flow applications requiring relatively high pumping pressure and that handle viscous liquids. In higher flow applications, a sufficient turbulence is present and air or vapors mix with the pumped liquid to purge the pumping chambers of the gases.

The performance chart of a typical 2-in (51-mm) air-operated, double-diaphragm pump (see Figure 14) is similar to that of other pump types but contains air consumption rather than horsepower consumption. With a constant supply pressure of compressed air, work and energy relationships in the air chambers, as well as liquid flow losses within the pump, result in a downward sloping head-capacity curve, similar to a centrifugal pump. The following are noteworthy features of air-operated diaphragm pumps:

- With the pump shut off, there is no power consumption. Air consumption is approximately proportional to the flow rate; there is zero air consumption at a zero flow rate and maximum air consumption at a maximum flow rate. This feature enables diaphragm pumps to be used in applications where the flow rate must be varied over a wide range or from no flow to a high flow rate.





**FIGURE 9** Cross-section of an air-operated double-diaphragm pump with flap check valves (Ingersoll-Rand Fluid Products)

- The pump discharge pressure remains the same for a given capacity and air inlet pressure regardless of the specific gravity of the liquid being pumped. The discharge head varies with the specific gravity of the pumped fluid, because pressure and not head is primarily maintained by the air pressure. For centrifugal pumps, the discharge pressure is directly proportional to the specific gravity of the liquid being pumped, while head is fixed at a given point on the performance curve. The supplied air pressure, pump flow rate, and *NPSH* set the discharge pressure for a given air operated pump, not the head, which is a characteristic of a centrifugal pump operated at a fixed speed.
- The *NPSH* required for an air-operated diaphragm pump is defined in the same manner as with any reciprocating pump. The *NPSH* required is determined to occur when the volumetric efficiency drops by a measurable amount (normally 3%) at a fixed speed or flow rate.

### **MATERIALS OF AIR-OPERATED DIAPHRAGM PUMPS**

Check valves for diaphragm pumps are of three types: flap, ball, and poppet (see Figure 15). Flap valves preferably hang in a vertical position with a horizontal flow through the valves. Their principle advantage is the capability to handle large objects in suspension. Flap valves with elastomeric hinges are extensively used. Ball valves are arranged to provide a vertical flow through the valve seats. Poppet valves are usually guided by a valve stem and are spring-loaded. The poppet type of valve is not position-sensitive and can





FIGURE 10 ARO air-operated double-diaphragm pump with flap check valves (Ingersoll-Rand Fluid Products)

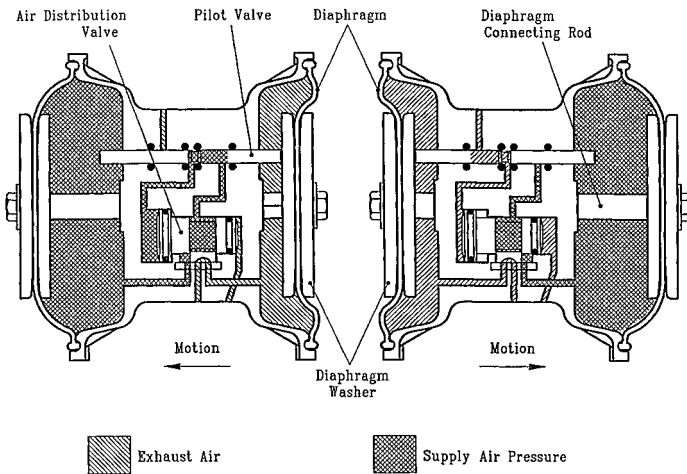
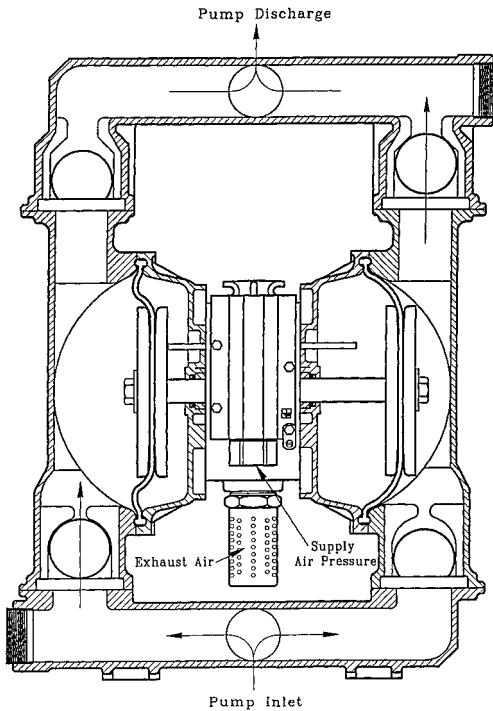


FIGURE 11 Cross-section of an air-operated double-diaphragm pump air motor operation (Ingersoll-Rand Fluid Products)



**FIGURE 12** Cross-section of an air-operated double-diaphragm pump with ball check valves (Ingersoll-Rand Fluid Products)

operate in any orientation. Since many diaphragm pumps are used to pump abrasive slurries, the valves usually have elastomeric faces or are elastomeric balls. Large ball check valves may have metal cores covered by a thick wall of synthetic rubber. They may also be made of solid rubber, a thermoplastic elastomer, or Teflon®.

Diaphragms are customarily made of fabric-reinforced synthetic rubber, thermoplastic elastomers, or PTFE. Diaphragm materials include most of the synthetic rubbers: neoprene, Buna N, EPR, Viton®, thermoplastic elastomers such as Hytrel® and Santoprene® as well as Teflon®. Many combinations of pump and diaphragm materials can cover a wide range of pumped products. For some solvents and aggressive acids or alkalis, Teflon® diaphragms can be used either directly or as an overlay on the conventional diaphragm.

The diaphragms in air-operated, double-diaphragm pumps are essentially balanced and act simply as membranes separating the compressed air from the product being pumped. The only unbalance occurs during the suction stroke of one diaphragm while it is being pulled by the shaft-connected other diaphragm. When the suction lift is minimal, the unbalance may be negligible.

Pump case materials include cast iron, aluminum, stainless steel, Carpenter 20, Hastelloy C, and plastics reinforced with glass or metal fibers.

## APPLICATIONS OF AIR-OPERATED DIAPHRAGM PUMPS

**General** Diaphragm pumps are ideally suited for handling abrasive slurries because 1) the liquid velocity through the check valves and pumping chambers does not exceed the



FIGURE 13 ARO air-operated double-diaphragm pump with ball check values (Ingersoll-Rand Fluid Products)

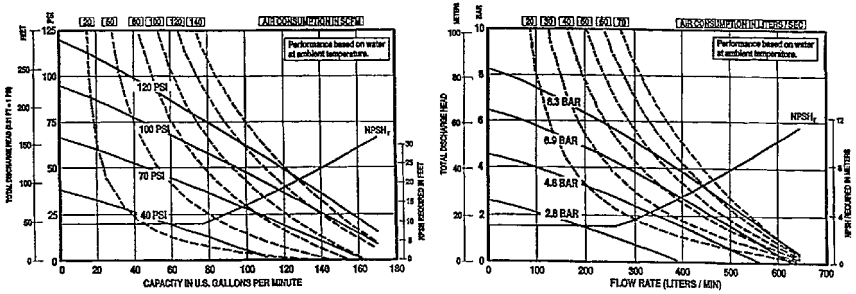


FIGURE 14 Performance curve for a 2-in air-operated double-diaphragm pump

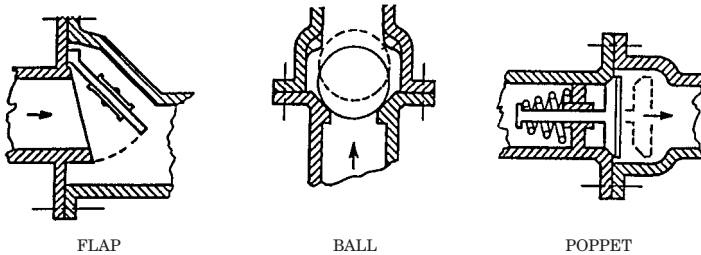


FIGURE 15 Three basic types of check valves

pipeline velocity and 2) the scouring and abrasions from the slurry are minimal. Because no close-fit sliding or rubbing parts exist and velocities are low, these pumps can be used for liquids with viscosities up to 50,000 SSU (11,000 cSt). Because the turbulence and mixing are minimal, they are ideally suited for shear-sensitive materials, such as latex.

**Pumping Dry Powders** Since diaphragm pumps can pump air as well as liquids, they are used successfully to pump dry powders. The air acts as a fluid medium for the powders in suspension, and the pump moves the air containing the suspended powder. Sometimes it is necessary to inject air into the powder to lower the apparent specific gravity and to get the powder into suspension.

**Pump Controls** An air pressure regulator in the compressed air supply line can control the pumping pressure. An air line valve can control the pumping rate. Thus, the pressure and capacity are easily controlled. Although air-operated diaphragm pumps are displacement pumps, they are not positive ones. The maximum pumping pressure cannot exceed the pressure of the compressed air powering the pumps. Table 1 describes the control of diaphragm pumps with the features inherent with each drive type.

**Liquids Handled and Applications** A variety of liquids can be handled by AODPs, yet the compatibility of pump case materials, valve materials, and diaphragms is the basic application limitation. Liquids and slurries handled by diaphragm pumps include ceramic slurry, paint, cement grout, chemicals, glue, resins, petroleum products, driller's mud, mill scale, ore concentrates, printer's ink, sewage, filter aids, latex, waste oils, wood preservatives, core washes, asphaltic coatings, bilge waste, radioactive waste, lapping compounds, porcelain frit, mine tailings, volatile solvents, coolants with metal fines, varnish, acids, coatings, soapstone slurries, explosives, lime slurries, yeast, chocolate, and wine. Typical applications of AODPs include tank and container loading and unloading, fluid filtration, spray painting, adhesive application, process mixing and batching, cutting oil, machine coolant, lubrication, sump pumping, dewatering, and waste water treatment.

### LIMITATIONS AND ADVANTAGES OF AIR-OPERATED DIAPHRAGM PUMPS

This section outlines the pros and cons of AODPS. Table 1 also details the controls of the different types of pumps. The limitations of AODPs are as follows:

**TABLE 1** Control of diaphragm pumps

Feature	Electro-Magnetically Driven	Mechanically Driven	Hydraulically Driven	Air-Operated
Can run dry:	Yes	Yes	Yes	Yes
Self-priming:	Yes	Yes	Yes	Yes
Discharge can be shutoff without damage:	Yes	No	Yes	Yes
Relief valve required:	No	Yes	Integral to pump	No
Flow controlled by:	Motor speed or stroke-length adjustment	Motor speed or stroke-length adjustment	Motor speed or stroke-length adjustment	Motor speed or discharge valve

- AODPs are not practical for pumping rates above about 300 gpm (1150 ℓ/m).
- AODPs are not manufactured for operating air pressures above 125 lb/in<sup>2</sup> gauge (8.6 bar). However, some versions are available that increase the pressure ratio by 2:1 or 3:1.
- Ice formation in air motors can occur (basic to the physics of operation), but the effect can be minimized by proper application and design.
- Diaphragms have a finite life. Fluids with abrasives and higher process temperatures can limit a diaphragm's life, but many material choices are available, including Teflon<sup>®</sup>, and several thermoplastic elastomers.

An AODP's advantages are as follows:

- They are self-priming from a dry start.
- The pumps have an infinitely variable flow rate and pressure-within-pressure and capacity ranges.
- AODPs have no dynamic seals or packing.
- They can run dry indefinitely.
- The discharge can be throttled to zero flow indefinitely.
- No air is used when the AODP is deadheaded. Electrically driven pumps will consume a significant portion of the rated power when no demand flow exists.
- AODPs are suited for use in hazardous environments (no electric power required).
- Power is used in proportion to the pumping rate.
- They can be used in confined areas without heat buildup.
- AODPs can pump abrasive slurries and solids in suspension.
- The pumps can handle viscous liquids up to 50,000 SSU (11,000 cSt).
- A minimal degradation of the viscosity of shear-sensitive materials occurs.
- They can pump dry powders in air suspension.
- No close-fit, sliding, or rotating parts come in contact with liquid.
- No bypass is required as in other displacement pumps.
- When properly maintained, there is zero leakage.
- They are simple to maintain and to repair.
- There is no bedplate and no coupling to align.
- AODPs can be used in handling aggressive chemical solutions.
- They can handle a wider range of materials than any other type of pump.

---

# SECTION 3.7

---

# SCREW PUMPS

---

J. R. BRENNAN  
G. J. CZARNECKI  
J. K. LIPPINCOTT  
A. J. PRANG

Screw pumps are a special type of rotary positive displacement pump in which the flow through the pumping elements is truly axial. The liquid is carried between screw threads on one or more rotors and is displaced axially as the screws rotate and mesh (see Figure 1). In all other rotary pumps, the liquid is forced to travel circumferentially, thus giving the screw pump with its unique axial flow pattern and low internal velocities a number of advantages in many applications where liquid agitation or churning is objectionable.

The applications of screw pumps cover a diversified range of markets including navy, marine, and utilities fuel oil services; marine cargo; industrial oil burners; lubricating oil services; chemical processes; petroleum and crude oil industries; power hydraulics for navy and machine tools; and many others. The screw pump can handle liquids in a range of viscosities, from molasses to gasoline, as well as synthetic liquids in a pressure range from 50 to 5000 lb/in<sup>2</sup> (3.5 to 350 bar) and flows up to 8000 gal/min (1820 m<sup>3</sup>/h).

Because of the relatively low inertia of their rotating parts, screw pumps are capable of operating at higher speeds than other rotary or reciprocating pumps of comparable displacement. Some turbine-attached lubricating oil pumps operate at 10,000 rpm and even higher. Screw pumps, like other rotary positive displacement pumps, are self-priming and have a delivery flow characteristic, which is essentially independent of pressure, provided there is sufficient viscosity in the liquid being pumped.

Screw pumps are generally classified into single- or multiple-rotor types. The latter is further divided into timed and untimed categories.

The single-screw or progressive cavity pump (see Figure 2) has a rotor thread that is eccentric to the axis of rotation and meshes with internal threads of the stator (rotor housing or body). Alternatively, the stator is made to wobble along the pump centerline.

Multiple-screw pumps are available in a variety of configurations and designs. All employ one driven rotor in a mesh and one or more sealing rotors. Several manufacturers have two basic configurations available: single-end (in Figure 3) and double-end (in Figure 4) construction, of which the latter is the better known.

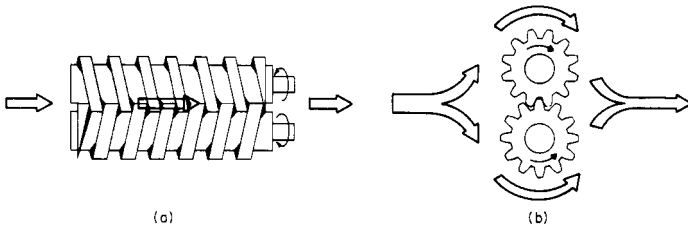


FIGURE 1 Diagrams of screw and gear elements, showing (a) axial and (b) circumferential flow.

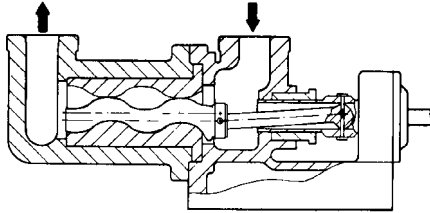


FIGURE 2 The single-screw or progressive cavity pump

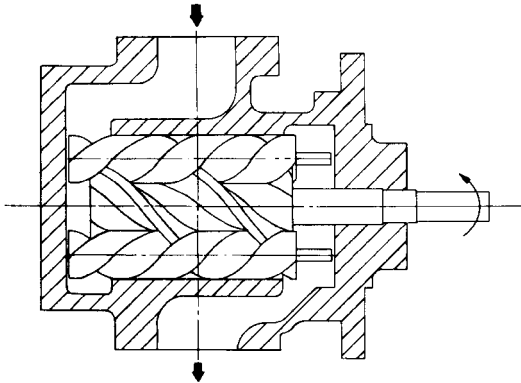


FIGURE 3 Multiple-screw single-end arrangement.

As with every pump type, certain advantages and disadvantages can be found in a screw pump design. These should be recognized when selecting the best pump for a particular application. The **advantages** of a screw pump design are as follows:

- A wide range of flows and pressures
- A wide range of liquids and viscosities
- High speed capability, allowing the freedom of driver selection
- Low internal velocities
- Self-priming, with good suction characteristics
- A high tolerance for entrained air and other gases

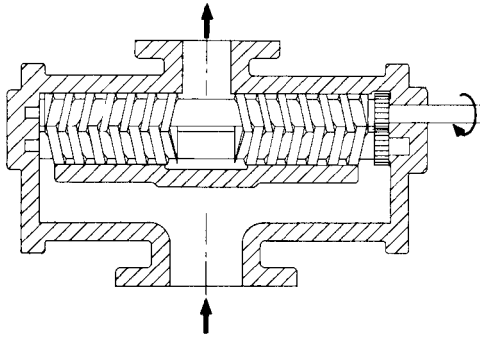


FIGURE 4 Multiple-screw double-end arrangement.

- Low velocities for minimum churning or foaming
- Low mechanical vibration, pulsation-free flow, and quiet operation
- A rugged, compact design that is easy to install and maintain
- High tolerance to contamination in comparison with other rotary pumps

The **disadvantages** are as follows:

- A relatively high cost because of close tolerances and running clearances
- Performance characteristics sensitive to viscosity changes
- High pressure capability requires long pumping elements

## THEORY

---

In screw pumps, it is the intermeshing of the threads on the rotors and the close fit of the surrounding housing that creates one or more sets of moving seals in a series between the pump inlet and outlet. These sets of seals or locks, as they are sometimes referred to, act as a labyrinth and provide the screw pump with its positive pressure capability. The successive sets of seals form fully enclosed cavities (see Figure 5) that move continuously from inlet to outlet. These cavities trap liquid at the inlet and carry it along to the outlet, providing a smooth flow.

**Delivery** Because the screw pump is a positive displacement device, it will deliver a definite quantity of liquid with every revolution of the rotors. This delivery can be defined in terms of displacement volume  $V_D$ , which is the theoretical volume displaced per revolution of the rotors and is dependent only upon the physical dimensions of the rotors. It is generally measured in cubic inches (cubic millimeters) per revolution. This delivery can also be defined in terms of theoretical capacity or flow rate  $Q_t$ , measured in U.S. gallons per minute (cubic meters per hour), which is a function of displacement and speed  $N$ :

$$\text{In USC units:} \quad Q_t = \frac{V_D N}{231}$$

$$\text{In SI units:} \quad Q_t = 6 \times 10^{-8} V_D N$$

If no internal clearances existed, the pump's actual delivered or net flow rate  $Q$  would equal the theoretical flow rate. Clearances, however, do exist with the result that whenever a pressure differential occurs, there will always be internal leakage from outlet to inlet. This leakage, commonly called *slip*  $S$ , varies depending upon the pump type or



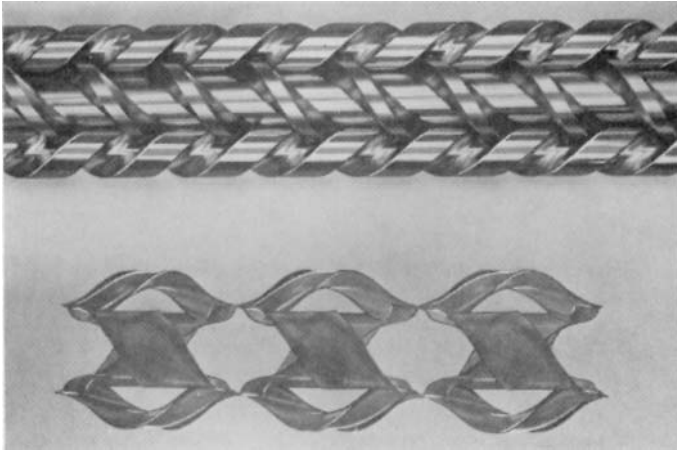


FIGURE 5 Axially moving seals and cavities. Alternate cavities filled with oil shown below. (Imo Pump)

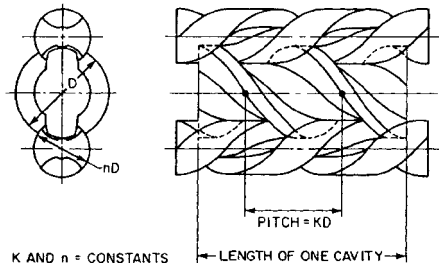


FIGURE 6 Screw-thread proportions, showing lead, diameters, and cavity length.

model, the amount of clearance, the liquid viscosity at the pumping conditions, and the differential pressure. For any given set of these conditions, the slip for all practical purposes is unaffected by speed. The delivered flow rate or net flow rate therefore is the theoretical flow rate less the slip:  $Q = Q_t - S$ . If the differential pressure is almost zero, the slip may be neglected and  $Q = Q_t$ .

The theoretical flow rate of any pump can readily be calculated if all essential dimensions are known. For any particular thread configuration, assuming geometric similarity, the size of each cavity mentioned earlier is proportional to its length and cross-sectional area. The thread pitch measured in terms of the same nominal diameter, which is used in calculating the cross-sectional area (see Figure 6), defines the length. Therefore, the volume of each cavity is proportional to the cube of this nominal diameter, and the pump's theoretical flow rate is also proportional to the cube of this nominal diameter and the speed of rotation  $N$  (rpm):

$$Q_t = kD^3N$$

or, bringing the pitch into evidence,

$$Q_t = k_1 \times \text{pitch} \times D^2N.$$

From Figure 6, where  $\text{pitch} = KD$ , it follows that  $k = k_1K$ .

Thus, for a given geometry, it can be seen that a relatively small increase in pump size can provide a large increase in flow rate.

Slip can also be calculated,<sup>1,2</sup> but usually it depends upon empirical values developed by extensive testing. These test data are the basis of the design parameters used by every pump manufacturer. Slip generally varies approximately as the square of the nominal diameter. The net flow rate therefore is

$$Q_t = kD^3N - S$$

**Pressure Capability** As mentioned earlier, screw pumps can be applied over a wide range of pressures, up to 5000 lb/in<sup>2</sup> (345 bar), provided the proper design is selected. Internal leakage must be restricted for high-pressure applications. Close-running clearances and high accuracy of the conjugate rotor threads are requirements. In addition, an increased number of moving seals between the inlet and outlet are employed, as in classic labyrinth-seal theory. The additional moving seals are obtained by a significant increase in the length of the pumping elements for a given size of rotor and pitch. Here the minimum pump length is sacrificed in order to gain pressure capability.

The internal leakage in the pumping elements resulting from the differential pressure between the outlet and inlet causes a pressure gradient across the moving cavities. The gradient is approximately linear (see Figure 7) when measured at any instant. Actually, the pressure in each moving cavity builds up gradually and uniformly from inlet to outlet pressure as the cavities move toward the outlet. In effect, the pressure capability of a screw pump is limited by the allowable pressure rise across any one set of moving seals. This pressure rise is sometimes referred to as *pressure per closure* or *pressure per lock* and generally is of the order of 125 to 150 lb/in<sup>2</sup> (8.6 to 10.3 bar) with normal running clearances, but it can go as high as 500 lb/in<sup>2</sup> (35 bar) when minimum clearances are employed.

**Design Concepts** The pressure gradient in the pump elements of all the types of screw pumps produces various hydraulic reaction forces. The mechanical and hydraulic techniques employed for absorbing these reaction forces are among the fundamental differences in the types of screw pumps produced by various manufacturers. Another fundamental difference lies in the method of engaging, or meshing, the rotors and maintaining the running clearances between them. Two basic design approaches are used:

- The *timed rotors* approach relies upon an external means for phasing the mesh of the threads and for supporting the forces acting on the rotors. In this concept, theoretically, the threads do not come into contact with each other or with the housing bores in which they rotate (refer to Figure 4).
- The *untimed rotors* approach relies on the precision and accuracy of the screw forms for the proper mesh and transmission of rotation. They utilize the housing bores as journal bearings supporting the pumping reactions along the entire length of the rotors (refer to Figure 3).

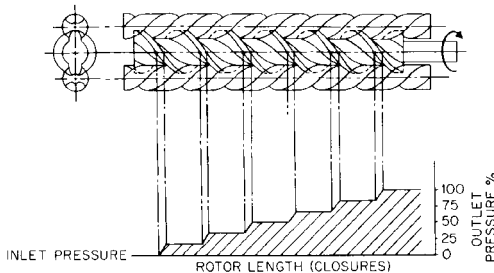


FIGURE 7 Pressure gradient along a screw set.

Timed screw pumps require separate timing gears between the rotors and separate support bearings at each end to absorb the reaction forces and maintain the proper clearances. Untimed screw pumps do not require gears or external bearings and thus are considerably simpler in design.

## CONSTRUCTION

---

**Basic Types** As indicated in the introduction, three major types of screw pumps exist:

- Single-rotor
- Multiple-rotor timed
- Multiple-rotor untimed

The second and third types are available in two basic arrangements, single-end and double-end. The double-end construction (see Figure 8) is probably the best-known version, as it has been by far the most widely used for many years because of its relative simplicity and compactness of design.

**Double-End Screw Pumps** The double-end arrangement is basically two opposed, single-end pumps or pump elements of the same size with a common driving rotor that has an opposed, double-helix design with one casing. As can be seen from Figure 8, the fluid enters a common inlet with a split flow going to the outboard ends of the two pumping elements and is discharged from the middle or center of the pump elements. The two pump elements are, in effect, pumps connected in parallel. The design can also be provided with a reversed flow for low-pressure applications. In either of these arrangements, all axial loads on the rotors are balanced, as the pressure gradients in each end are equal and opposite.

The double-end screw pump construction is usually limited to low- and medium-pressure applications, with 400 lb/in<sup>2</sup> (28 bar) being a good practical limit to be used for planning purposes. However, with special design features, applications up to 1400 lb/in<sup>2</sup> (97 bar) can be handled. Double-end pumps are generally employed where large flows are required or where very viscous liquids are handled.

**Single-End Screw Pumps** All three types of screw pumps are offered in the single-end construction. As pressure requirements in many applications have been raised, the sin-

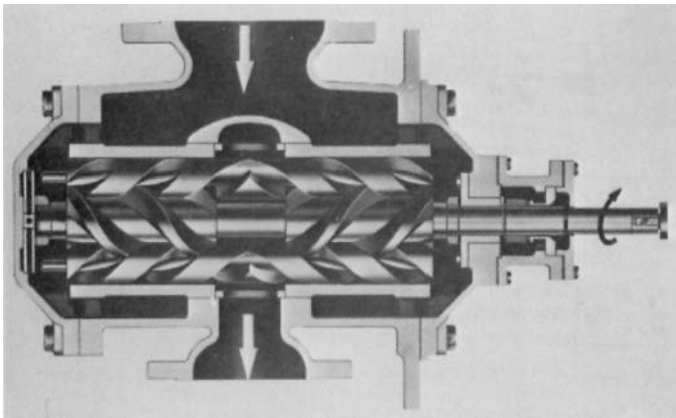
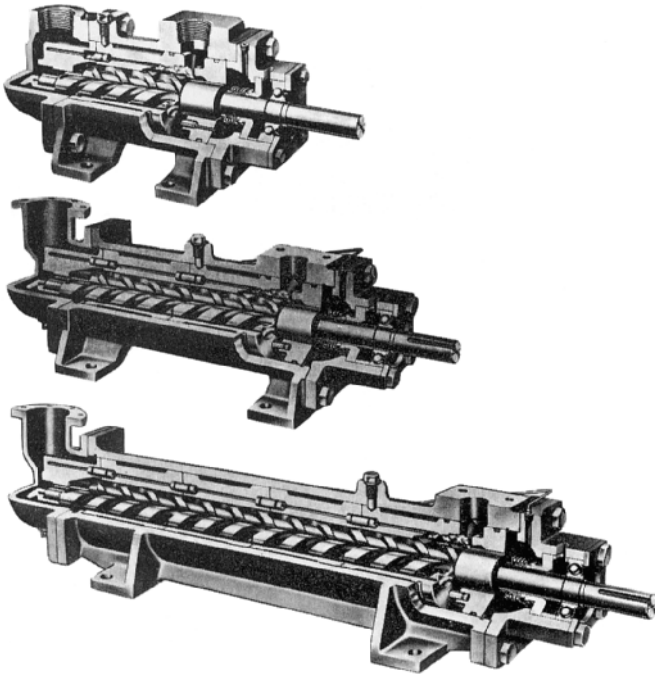
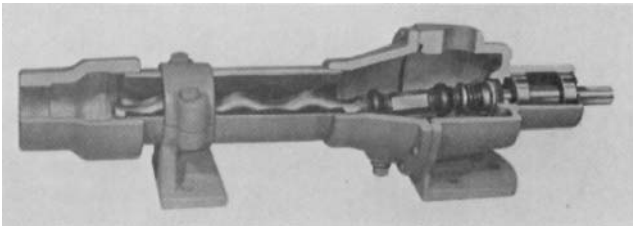


FIGURE 8 Double-end pump. Flow path provides axial balance. (Imo Pump)



**FIGURE 9** Increasing pump pressure capability by modular design (Imo Pump).



**FIGURE 10** Single-rotor pump. (Robbins-Meyers)

gle-end design has come into much wider use because it provides the only practical means for obtaining the greatest number of moving seals necessary for high-pressure capabilities. The main penalties of the single-end pump are the requirement and complexity of balancing the axial loads.

The single-end construction is most often employed for handling low-viscosity fluids at medium-to-high pressures or hydraulic fluids at very high pressures. The single-end design for high pressures is developed by literally stacking a number of medium-pressure, single-end pumping elements in a series within one pump casing (see Figure 9). The single-end construction also offers the best design arrangement for quantity manufacturing.

Special mention must be made of the single-end, single-rotor design (see Figure 10). The pump elements of this design consist of only a stator and one rotor. The stator has a

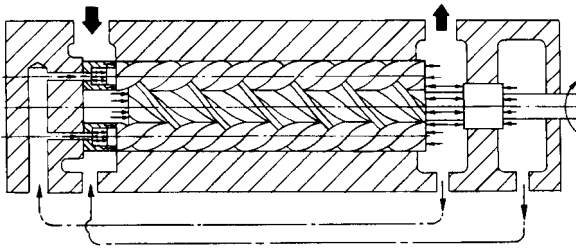


FIGURE 11 Axial balancing of power and idler rotors.

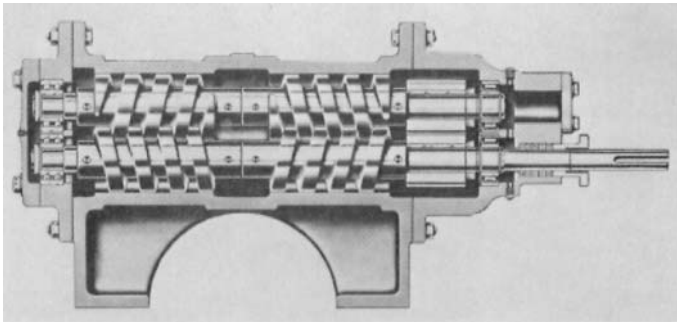


FIGURE 12 Double-end internal gear design. (Flowsolve Corporation)

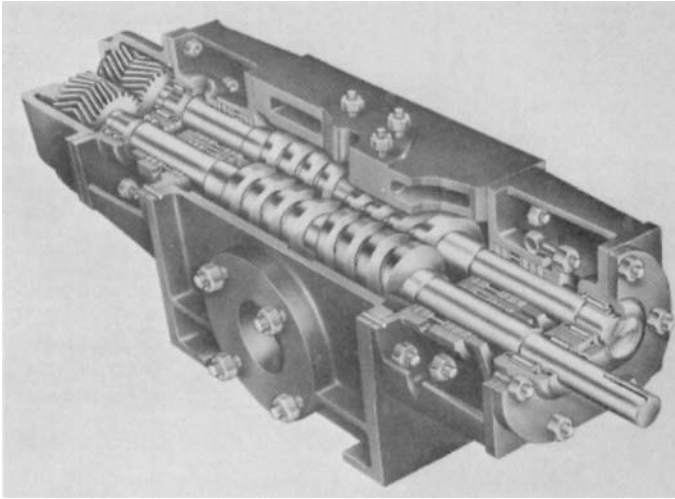
double-helix internal thread and is constructed of hard chrome stainless or tool steel material. One version of this design uses internally developed pressure in the pump to compress the elastomeric stator on the rotor, thus maintaining minimum running clearances.

In most single-end designs, special axial balancing arrangements must be used for each of the rotors, and, in this respect, the design is more complicated than the double-end construction. For smaller pumps, strictly mechanical thrust bearings can be used for differential pressures up to  $150 \text{ lb/in}^2$  (10.3 bar), while hydraulic balance arrangements are used for higher pressures. For large pumps, hydraulic balance becomes essential at pressures above  $50 \text{ lb/in}^2$  (3.5 bar).

Hydraulic balance is provided through the balance piston (see Figure 11) mounted on the rotors between the outlet and seal or bearing chambers, which are at inlet pressure. This piston is exposed to discharge pressure in the outlet chamber and is equal in area to the exposed area of the driven rotor threads; thus, the hydraulic forces on the rotor are canceled out.

**Timed Design** Timed screw pumps having timing gears and rotor support bearings are furnished in two general arrangements: internal and external. The internal version has both the gears and the bearings located in the pumping chamber and the design is relatively simple and compact (see Figure 12). This version is generally restricted to the handling of clean lubricating fluids, which serve as the only lubrication for the timing gears and bearings.

The external timing arrangement is the most popular and is extensively used. It has both the timing gears and the rotor support bearings located outside the pumping chamber (see Figure 13). This type can handle a complete range of fluids, both lubricating and non-lubricating, and, with proper materials, has good abrasion resistance. The timing gears and bearings are oil-bath-lubricated from an external source. This arrangement



**FIGURE 13** Double-end external gear design. (Warren)

requires the use of four stuffing boxes or mechanical seals, as opposed to the internal type, which employs only one shaft seal.

The main advantage of the timed screw pump is that the timing gears transmit power to the rotors with no contact between the screw threads, thus promoting long pump life. The gears and rotors are timed at the factory to maintain the proper clearance between the screws. With certain designs and loading characteristics, the bearings at each end of the rotating elements can support the rotors so that they do not come in contact with the housing; hence, no liner is required. One set of these bearings also positions and supports the timing gears. Under more heavily loaded conditions, the body bores act as sleeve bearings and provide additional support for the rotors.

The timing gears can be either spur or helical, herringbone, hardened-steel gears with tooth profiles designed for efficient, quiet, positive drive of the rotors. Antifriction radial bearings are usually of the heavy-duty roller type, while the thrust bearings, which position the rotors axially, are either double-row, ball-thrust or spherical-roller types.

The housing can be supplied in a variety of materials, including cast iron, ductile iron, cast steel, stainless steel, and bronze. In addition, the rotor bores of the housing can be lined with industrial hard chrome for abrasion resistance.

Since the rotors are not generally in metallic contact with the housing or with one another, they can also be supplied in a variety of materials, including cast iron, heat-treated alloy steel, stainless steel, Monel, and nitralloy. The outside of the rotors can also be furnished with a variety of hard coating materials such as nickel-based alloys, tungsten carbide, chrome oxide, or ceramic.

**Untimed Design** The untimed type of screw pump has rotors that have generated mating-thread forms that enable any necessary driving force to be transmitted smoothly and continuously between the rotors without the use of timing gears. The rotors can be compared directly with precision-made helical gears with a high helix angle. This design usually employs three rotor screws with a center or driven rotor that meshes with two close-fitting sealing or idler rotors symmetrically positioned about the central axis (see Figure 14). A close-fitting housing provides the only transverse bearing support for both driven and idler rotors.

The use of the rotor housing as the only means for supporting idler rotors is a unique feature of the untimed screw pump. No outboard support bearings are required on these rotors. The idler rotors in their related housing bores are, in effect, partial journal bearings

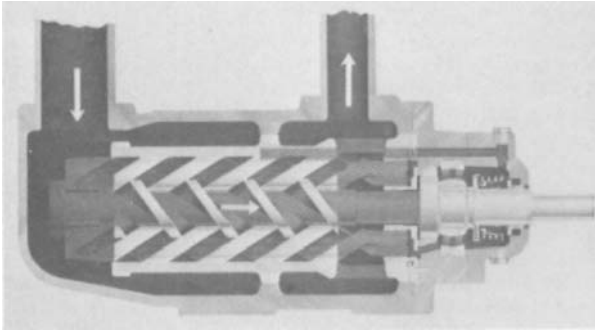


FIGURE 14 Single-end design. (Roper).

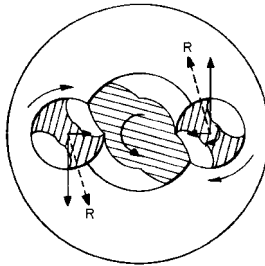


FIGURE 15 Force diagram on rotor set.

that generate a hydrodynamic film. The key parameters of rotor size, clearance, surface finish, speed, fluid viscosity, and bearing pressure are related as in a journal bearing. Because, in this design, the screws transmit the driving torque to the idlers and because the casing bores support the rotors, the pumped fluid must have some lubricating properties. This prevents this pump design from being used in applications with any solids or abrasives in the pumpage.

Since the idler rotors are supported by the bores along their entire length, no significant bending loads are applied to them. The central driven rotor is also not subjected to any significant bending loads because of the symmetrical positioning of the idler rotors and the use of two threads on all the rotors (see Figure 15). This is quite different from the two-rotor design common to the timed type where the hydraulic forces generated in the pump create bending loads on the intermeshing pairs of screws.

In contrast to timed pumps, the untimed design, with its absence of timing gears and bearings, appears very simple, but its success depends entirely upon the accuracy and finish of the rotor threads and rotor housing bores. Special techniques and machine tools have been developed to manufacture these parts. The combination of design simplicity and manufacturing techniques has enabled this design to be used for very long rotor lengths, with a multiplicity of sealing closures, for applications up to  $5,000 \text{ lb/in}^2$  (350 bar).

In special applications handling highly aerated oils, a four-rotor design is sometimes employed in the untimed type. Three idler rotors are equally spaced radially at  $120^\circ$  around the driven rotor. This design is not truly a positive displacement pump, and it falls outside the scope of this section.

The rotors in untimed pumps are generally made of gray or ductile iron or carbon steel. The thread surfaces are often hardened for high pressure and abrasive resistance. Flame hardening, induction hardening, and nitriding are currently used. Through-hardened tool steel or stainless steel can be used in some critical applications.



Rotor housings, or liners, are made of gray pearlitic iron, bronze, or aluminum alloy. In many instances, the bores as well as the rotors can be treated by the application of dry lubricant or toughening coatings. The pump casings are made of gray iron or ductile iron or cast steel where shock or other safety requirements demand it.

In many untimed designs, an antifriction bearing is employed on the shaft end of the driven rotor (refer to Figure 9) to provide precise shaft positioning for mechanical seal and coupling alignment. This bearing can be either an external grease-sealed bearing or an internal type with the pumped fluid providing the lubrication. The bearing also supports overhung loads with belt or gear drives.

**Seals** As with any rotary pump, the sealing arrangement for the shafts is important and is often critical. Every type of rotary seal has been used in screw pumps at one time or another. Except for canned or sealless arrangements, all types of pumps require at least one rotary seal on the drive shaft. The timed screw pumps with external timing and bearings require additional seals at each rotor end to separate the pumped fluid from the lubricating oil necessary for the gears and bearings.

For drive shafts, rotary mechanical seals as well as stuffing boxes or packings are used, depending on the manufacturer and/or customer preference. Double back-to-back arrangements or tandem mounted seals with a flushing liquid are sometimes used for very viscous or corrosive substances.

Many different sealing face materials such as carbon, bronze, cast iron, Ni-resist, carbides, or ceramics are used, along with different secondary elastomer seals of various materials chosen to suit the application. Balanced and non-balanced seals can also be used to handle significant pressures. In some pump designs, the seals are subjected to only the suction pressure, while in other designs the seals must seal against the full discharge pressure. In spite of these advantages, the stuffing box is still preferred by some users. The stuffing box requires regular maintenance and tightening, which many users find objectionable, but a mechanical seal failure usually results in a major shutdown.

## PERFORMANCE

---

Performance considerations of screw pumps are closely related to applications, and so any discussion must cover both. In the application of screw pumps, certain basic factors must be considered to ensure a successful installation. These are fundamentally the same regardless of the liquids to be handled or the pumping conditions.

In most cases, the pump selection for a specific application is not difficult if all the operating parameters are known. It is often quite difficult, however, to obtain this information, particularly inlet conditions and fluid viscosity. It is a common feeling that, inasmuch as the screw pump is a positive displacement device, these items are unimportant.

In any screw pump application—regardless of design—suction lift, viscosity, and speed are inseparable. The speed of operation is dependent upon viscosity and suction lift. If a true picture of these latter two items can be obtained, the problem of making a proper pump selection becomes simpler and the selection will result in a more efficient unit.

**Inlet Conditions** The key to obtaining good performance from a screw pump, as with all other positive displacement pumps, lies in a complete understanding and control of inlet conditions and the closely related parameters of speed and viscosity. To ensure quiet, efficient operation, it is necessary to completely fill the moving cavities between the rotor threads with liquid as they open to the inlet, and this becomes more difficult as the viscosity, speed, or suction lift increases. It can be said that, if the liquid can be properly introduced into the rotor elements, the pump will perform satisfactorily.

It must be remembered that a pump does not pull or lift liquid into itself. Some external force must be present to push the liquid into the rotor threads initially. Normally, atmospheric pressure is the only force present, but in some applications a positive inlet pressure is available.

Naturally, the more viscous the liquid, the greater the resistance to the flow, and therefore the slower the rate of filling the moving cavities of the threads in the inlet. Conversely,



**TABLE 1** Internal axial velocity limits

Liquid	Viscosity, SSU	Velocity, ft/s (m/s)
Diesel oil	32	30 (9)
Lubricating oil	1,000	12 (3.7)
#6 fuel oil	7,000	7 (2.1)
Cellulose	60,000	$\frac{1}{2}$ (0.15)

low-viscosity liquids flow more readily and will quickly fill the rotor cavities. It is obvious that if the rotor elements are moving too fast, the filling will be incomplete and a reduction in output will result. To obtain complete filling, the rate of liquid flow into the pumping elements should always be greater than the rate of cavity travel. Table 1 lists examples of safe internal axial velocity limits found from experience by one screw pump manufacturer for various liquids and pumping viscosities with only atmospheric pressure available at the pump inlet.

It is quite apparent from Table 1 that the pump speed must be selected to satisfy the viscosity of the liquid being pumped. The internal axial velocity is directly related to the pump speed of rotation and to the screw thread lead. The lead is the advancement made along one thread during a complete revolution of the driven rotor, as measured along the axis. In other words, it is the distance traveled by the moving cavity in one complete revolution of the driven rotor. This is also referred to as *pitch* on single start screws.

**Fluids and Vapor Pressure** In many cases, screw pumps handle a mixture of liquids and gases, and therefore the general term *fluid* is more descriptive. Most of these fluids, especially petroleum products because of their complex nature, contain certain amounts of entrained and dissolved air or some other gas, which is released as a vapor when the fluid is subject to reduced pressures. If the pressure drop required to overcome entrance losses is sufficient to reduce the static pressure significantly, vapors are released in the rotor cavities and cavitation results.

Vapor pressure is an important fluid property, which must always be recognized and considered. This is particularly true of volatile petroleum products such as gasoline. Crude oil is an example of a volatile fluid where the vapor pressure has been overlooked in the past when applying screw pumps. The vapor pressure of a liquid is the absolute pressure at which the liquid will change to a vapor at a given temperature. A common example is that the vapor pressure of water at 212°F (100°C) is 14.7 lb/in<sup>2</sup> (1 bar). For petroleum products, as will be discussed in Subsection 9.19.1, the *true vapor pressure* (TVP) at any temperature is a function of the *Reid vapor pressure* (absolute) (RVP). RVP is determined by the ASTM Standard D-323 procedure and is quoted at 100°F (38°C). TVP at this temperature is slightly higher than the RVP.

In all screw pump applications, the absolute static pressure must never be allowed to drop below the vapor pressure of the fluid. This will prevent vaporization or cavitation. Cavitation, as mentioned previously, results when fluid vaporizes in the pump inlet because of incomplete filling of the pump elements and a reduction of pressure. Under these conditions, vapor bubbles, or voids, pass through the pump and collapse as each moving cavity moves into a domain of higher pressure. The result is noisy vibrations, the severity depending on the extent of vaporization or the incomplete filling and the magnitude of the discharge pressure. Also, an attendant reduction in output occurs. It is therefore important to be fully aware of the characteristics of entrained and dissolved air as well as of the vapor pressure of the fluid to be handled. This is particularly true when a suction lift exists.

**Net Positive Suction Head** The suction conditions of screw pumps are normally defined by the *Net Positive Suction Head* (NPSH) available at the pump inlet. In some cases with systems open to the atmosphere, the inlet conditions can also be defined as suc-

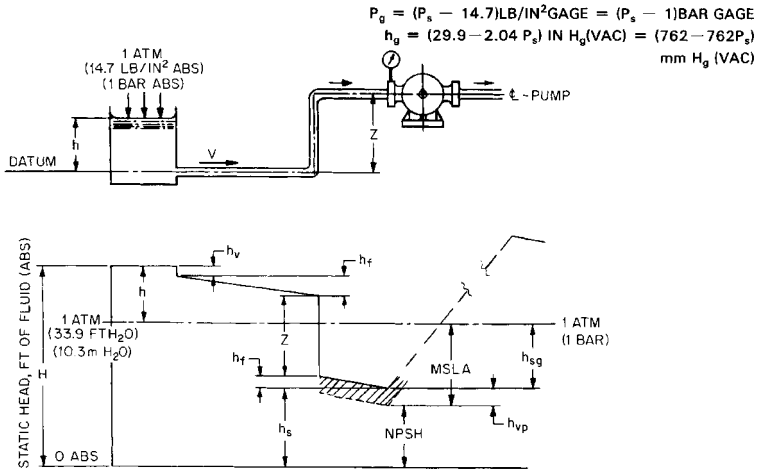


FIGURE 16 Relationship of hydraulic gradient, *NPSH*, and *MSLA*.

tion lift. Suction lift occurs when the total available pressure at the pump inlet is below the atmospheric pressure and is normally the result of a change in elevation and pipe friction. Since atmospheric pressure at sea level corresponds to 14.7 lb/in<sup>2</sup> (1 bar) absolute, or 30 in Hg (762 mm Hg), in a system with the suction open to the atmosphere, this is the maximum amount of pressure available for moving the fluid, and suction lift cannot exceed these figures. In practice, the available pressure is lower because some of it is used up in overcoming friction in the inlet lines, valves, and fittings. It is considered the best practice to keep the suction lift as low as possible to ensure that an adequate *NPSH* is available to fill the suction cavities of the pumping screw. In all cases, the system *NPSHA* (available) should be greater than the pump *NPSHR* (required). Figure 16 provides an example of *NPSH* with the following values:

$NPSHA = \text{ATM} + \text{reservoir liquid level} - \text{elevation head} - \text{frictional head loss} + \text{velocity head}$ , where ATM is the atmospheric pressure expressed in the height of a column of the liquid being pumped.

$$NPSHA = \frac{C_1 h_b}{\text{sp. gr.}} + h - Z - h_f + \frac{V^2}{2g} - h_{vp}$$

where:  $C_1 = \begin{cases} 33.9/29.92 = 1.133 \text{ for USCS units} \\ 10.3/760 = 0.136 \text{ for SI units} \end{cases}$

If the pressure at the inlet of the pump ( $P_g$ ) is known, the *NPSHA* is calculated as

$$NPSHA = \frac{C_1 h_b}{\text{sp. gr.}} + \frac{C_2 P_g}{\text{sp. gr.}} + \frac{V^2}{2g} - h_{vp}$$

where:  $C_2 = \begin{cases} 2.31 \text{ for USCS units} \\ 10.20 \text{ for SI units} \end{cases}$

If the suction pressure is a vacuum or negative gage reading, the *NPSHA* is calculated as

$$NPSHA = \frac{C_1 h_b}{\text{sp. gr.}} - \frac{C_3 h_g}{\text{sp. gr.}} + \frac{V^2}{2g} - h_{vp}$$

where:  $C_2 = \begin{cases} 1.133 & \text{for USCS units} \\ 0.01360 & \text{for SI units} \end{cases}$

The maximum suction lift available is calculated as

$$MSLA = \frac{C_1 h_b}{\text{sp. gr.}} - NPSH$$

The definitions are as follows:

$V$  = velocity, ft/s (m/s)

$P_g, h_g$  = pressure gage readings at the pump inlet flange lb/in<sup>2</sup> (bar) gage and in Hg (mm Hg) (vac)

$P_s$  = absolute static pressure at pump inlet, lb/in<sup>2</sup> (bar) abs

$h_g, h_{sg}$  = static head at pump inlet, ft (m) of liquid abs or gage

$Z$  = elevation head, ft (m) in reference to datum

$h$  = reservoir liquid level, ft (m) in reference to datum

$h_b$  = barometric pressure, in Hg (mm Hg) absolute

$h_v, h_f$  = velocity head and friction head loss, ft (m)

$P_{vp}, h_{vp}$  = liquid vapor pressure, lb/in<sup>2</sup> (bar) abs

$P_{sv}$  = net positive inlet pressure, lb/in<sup>2</sup> (bar) abs

$NPSH$  = net positive suction head, ft (m) of liquid abs

$P_f$  = frictional pressure loss, lb/in<sup>2</sup> (bar)

$MSLA$  = maximum suction lift available from pump, ft (m) of pumped liquid in the above equation—or in Hg (mm Hg) (vac)

sp. gr. = specific gravity of pumped liquid

The majority of screw pumps operate with suction lifts of approximately 5 to 15 in Hg (127 to 381 mm Hg). Lifts corresponding to 24 to 25 in Hg (610 to 635 mm Hg) are not uncommon, and installations can operate satisfactorily when the absolute suction pressure is much lower. In the latter cases, however, the pumps usually take the fluid from tanks under a vacuum, and no entrained or dissolved air or gases are present. Great care must be taken when selecting pumps for these applications since the inlet losses can easily exceed the net suction head available for moving the fluid into the pumping elements.

The defining of suction requirements by the user and the stating of pump suction capabilities by the manufacturer have always been complex problems. In many cases, the  $NPSHA$  is difficult to predict due to changes in the fluid characteristics and the operating conditions. In addition, the  $NPSH$  required by the pump is a function of many variables, such as pump design, fluid characteristics, and operating conditions. If the operating conditions can be accurately defined, the pump manufacturers can predict the  $NPSHR$  and in many cases can provide pump modifications that can minimize the  $NPSHR$ .

To enable the pump manufacturer to offer the most economical selection and also assure a quiet installation, accurate suction conditions should be clearly stated. Specifying a lower  $NPSHA$  than actually exists may result in selection of a pump that operates at a lower speed than necessary. This means not only a larger and more expensive pump, but also a costlier driver. If the  $NPSHA$  is lower than stated, the outcome could be a noisy pump installation.

Many known instances of successful installations exist where screw pumps were properly selected for low  $NPSHA$  conditions. Unfortunately, many other installations with equally low  $NPSHAs$  exist, which are not so satisfactory. This is because proper consideration was not given at the time the pump was specified and selected to the actual suction conditions at the pump inlet. Frequently, suction conditions are given as "flooded" simply because the source feeding the pump is above the inlet. In many cases, no consideration is given to outlet losses from the tank or to pipe friction in the inlet lines, and these can be exceptionally high in the case of viscous liquids.

When it is desired to pump extremely viscous products, care should be taken to use the largest feasible size of suction piping to eliminate all unnecessary fittings and valves, and to place the pump as close as possible to the source of the supply. In addition, it may be necessary to supply the liquid to the pump under some pressure, which can be supplied by elevation, air pressure, or mechanical means. These actions will provide the maximum *NPSH* possible to the pump inlet.

**Entrained and Dissolved Air** As mentioned previously, a factor that must be given careful consideration is the possibility of entrained air or other gases in the liquid to be pumped. This is particularly true of installations where recirculation occurs and the fluid is exposed to air through either mechanical agitation, leaks, or improperly located drain lines.

Most liquids will dissolve air or other gases retaining them in the solution, the amount being dependent upon the liquid itself and the pressure to which it is subjected. It is known, for instance, that lubricating oils at atmospheric temperatures and pressures will dissolve up to 10 percent air by volume and that gasoline will dissolve up to 20 percent. When pressures below the atmosphere exist at the pump inlet, dissolved air will come out of the solution. Both this and the entrained air will expand in proportion to the existing partial pressure of the air (= absolute pressure minus the vapor pressure of the liquid). This expanded air will accordingly take up a proportionate part of the available volume of the moving cavities, with a consequent reduction in delivered flow rate.

One of the apparent effects of handling liquids containing entrained or dissolved gas is noisy pump operation. When such a condition occurs, it is usually dismissed as cavitation. Then too, many operators never expect anything but noisy operation from rotary pumps. This should not be the case, particularly with screw pumps. With properly designed systems and pumps, quiet, vibration-free operation can be produced and should be expected. Noisy operation is inefficient; steps should be taken to make corrections until the objectionable conditions are overcome. Correct system inlet designs and optimized pump designs with a proper speed selection can go a long way toward overcoming the problem.

In some applications, the amount of gas can be significant and can make up the majority of the fluid volume. See the later subsection on handling special multiphase applications.

**Viscosity** It is not often that a screw pump is called upon to handle liquids at a constant viscosity. Normally, because of temperature variations, a wide range of viscosities will be encountered. For example, a pump may be required to handle a viscosity range from 150 to 20,000 SSU, the higher viscosity usually resulting from cold-starting conditions. This is a perfectly satisfactory range for a screw pump, but a better and a more economical selection may be possible if additional information can be obtained. This information includes such things as the amount of time the pump is required to operate at the higher viscosity, whether the motor can be overloaded temporarily, whether a multi-speed motor can be used, and if the discharge pressure will be reduced during the period of high viscosity.

Quite often, only the type of liquid is specified, not its viscosity, and assumptions must be made for the operating range. For instance, Bunker C or No. 6 fuel oil is known to have a wide range of viscosity values and usually must be handled over a considerable temperature range. The normal procedure in a case of this type is to assume an operating viscosity range of 20 to 700 SSF. The maximum viscosity, however, might easily exceed the higher value if extra-heavy oil is used or if exceptionally low temperatures are encountered. If either should occur, the result may be improper filling of the pumping elements, noisy operation, vibration, and overloading of the motor.

Although it is the maximum viscosity and the expected *NPSHA* that are used to determine the size of the pump and to set the speed, it is the minimum viscosity that affects the capacity. Screw pumps must always be selected to give the specified capacity when handling the expected minimum viscosity since this is the point at which the maximum slip, and hence minimum flow rate, occurs (see Figure 17). It should also be noted that the minimum viscosity often determines the selection of the pump model because most manufacturers have special lower-pressure ratings for handling liquids having a viscosity of less than 100 SSU.

**Non-Newtonian Liquids** The viscosity of most liquids is unaffected by any agitation or shear to which they may be subjected as long as the temperature remains constant. These

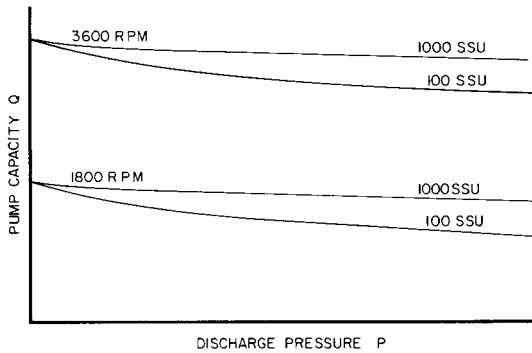


FIGURE 17 Head-capacity (flow rate) performance curve with viscosity a parameter—for two speeds.

liquids are accordingly known as *true* or *Newtonian* liquids, for which the viscosity is constant. Another class of liquids, however, such as cellulose compounds, glues, greases, paints, starches, slurries, and candy compounds, displays changes in viscosity as agitation is varied at constant temperature. The viscosity of these substances depends upon the shear rate at which it is measured, and these fluids are termed *non-Newtonian*.

If a substance is known to be non-Newtonian, the expected viscosity under the actual pumping conditions should be determined, because it can vary quite widely from the viscosity under static conditions. Since a non-Newtonian substance can have an unlimited number of viscosity values (as the shear rate is varied), the term *apparent viscosity* is used to describe its viscous properties. The apparent viscosity is expressed in absolute units and is a measure of the resistance to the flow at a given shear rate. It has meaning only if the shear rate used in the measurement is also given.

The grease-manufacturing industry is very familiar with the non-Newtonian properties of its products, as evidenced by the numerous curves that have been published of the apparent viscosity plotted against the rate of shear. The occasion is rare, however, when one can obtain accurate viscosity information when it is necessary to select a pump for handling these products.

It is practically impossible in most instances to give the viscosity of grease in the terms most familiar to the pump manufacturer, such as Saybolt Seconds Universal or Saybolt Seconds Furol, but only a rough approximation would be of great help. For applications of this type, data taken from similar installations are most helpful. Such information should consist of the type, size, flow rate, and speed of the installed pumps; the suction pressure; the temperature at the pump inlet flange; the total working suction head; and, above all, the pressure drop in a specified length of piping. From the latter, a satisfactory approximation of the effective viscosity under the operating conditions can be obtained.

If accurate shear rate-viscosity data are available, they can be used to more accurately predict pump performance. The shear rates in various areas of the pump can be calculated to determine the viscosity changes of the liquid as it passes through the pump. In this way, the effect on suction loss, slip, and friction loss can be analyzed to help predict the *NPSH*, flow rate, and power.

**Speed** It was previously stated that viscosity and speed are closely tied together and that it is impossible to consider one without the other. Although rotative speed is the ultimate outcome, the basic speed that the manufacturer must consider is the internal axial velocity of the liquid going through the rotors. This is a function of pump type, design, and size.

Rotative speed should be reduced when handling liquids of high viscosity. The reasons for this are not only the difficulty of filling the pumping elements, but also the mechanical losses that result from the shearing action of the rotors on the substance handled. The

reduction of these losses is frequently of more importance than relatively high speeds, even though the latter might be possible because of positive inlet conditions.

**Capacity** The delivered capacity (flow) of any screw pump, as stated earlier, is the theoretical capacity less the internal leakage, or the slip, when handling vapor-free liquids. For a particular speed,  $Q = Q_t - S$ , where the standard unit of  $Q$  and  $S$  is the U.S. gallon per minute (cubic meter per minute).

The delivered capacity of any specific rotary pump is reduced by

- Decreasing speed
- Decreased viscosity
- Increased differential pressure

The actual speed must always be known. Most often, it differs somewhat from the rated or nameplate specification. This is the first item to be checked and verified in analyzing any pump performance. It is surprising how often the speed is incorrectly assumed and later found to be in error.

Because of the internal clearances between rotors and their housing, lower viscosities and higher pressures increase the slip, which results in a reduced flow rate for a given speed. The impact of these characteristics can vary widely for the various types of pumps. The slip, however, is not measurably affected by changes in speed and thus becomes a smaller percentage of the total flow at higher speeds. This is a significant factor in the handling of low-viscosity fluids at higher pressures, particularly in the case of untimed screw pumps that favor high speeds for the best results and best volumetric efficiency. This will not generally be the case with pumps having support-bearing speed limits.

Pump volumetric efficiency  $E_v$  is calculated as

$$E_v = \frac{Q}{Q_t} = \frac{Q - S}{Q_t}$$

with  $Q_t$  varying directly with speed. As stated previously, the theoretical capacity of a screw pump varies directly as the cube of the nominal diameter. Slip, however, varies approximately with the square of the nominal diameter. Therefore, for a constant speed and geometry, doubling the rotor size will result in an eightfold increase in theoretical flow rate and only a fourfold increase in slip. It follows therefore that the volumetric efficiency improves rapidly with increases in the rotor size.

On the other hand, viscosity changes affect the slip inversely to a certain power, which has been determined empirically. An acceptable approximation for the range of 100 to 10,000 SSU is obtained by using the 0.5 power index. Slip varies approximately with the differential pressure, and a change from 400 SSU to 100 SSU will double the slip in the same way as will a differential pressure change of 100 to 200 lb/in<sup>2</sup> (7 to 14 bar):

$$S = K\sqrt{\frac{P}{\text{viscosity}}}$$

Figure 18 shows the flow rate and volumetric efficiencies as functions of pump size.

**Pressure** Screw pumps do not in themselves create pressure; they simply transfer a quantity of fluid from the inlet to the outlet side. The pressure developed on the outlet side is solely the result of resistance to the flow in the discharge line. The slip characteristic of a particular pump type and model is one of the key factors that determine the acceptable operating range, and it is generally well defined by the pump manufacturer.

**Power** The brake horsepower (bhp), or, in SI units, the brake kilowatts, required to drive a screw pump is the sum of the theoretical liquid horsepower (kilowatts) and the internal power losses. The theoretical liquid power *twhp* (*tkW*) is the actual work done in moving the fluid from its inlet pressure condition to the outlet at the discharge pressure.

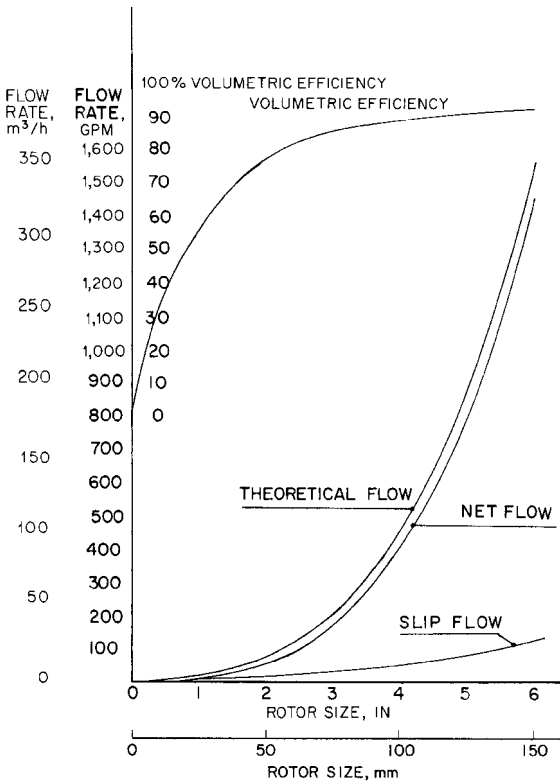


FIGURE 18 Flow rate and volumetric efficiency as functions of pump size.

Note that this work is done on all the fluid of the theoretical capacity, not just the delivered capacity, as the slip does not exist until a pressure differential  $DP$  occurs. Screw pump power ratings are expressed in terms of horsepower (550 ft-lbf/sec) in USCS units and in terms of kilowatts in SI units. The theoretical liquid horsepower (kilowatts) can be calculated as follows:

$$twhp = \frac{Q_t \Delta P}{1714} \left( tkW = \frac{Q_t \Delta P}{36} \right)$$

It should be noted that the theoretical liquid horsepower (kilowatts) is independent of the viscosity and is a function only of the physical dimensions of the pumping elements, the rotative speed, and the differential pressure.

The internal power losses are of two types: mechanical and viscous. The mechanical losses include all the power necessary to overcome the frictional drag of all the moving parts in the pump, including rotors, bearings, gears, and mechanical seals. The viscous losses include all the power lost from the fluid drag effects against all the parts in the pump as well as from the shearing action of the fluid itself. It is probable that the mechanical loss is dominant when operating at low viscosities and high speeds, and the viscous loss is the larger of these two losses at high-viscosity and slow-speed conditions.

In general, the losses for a given type and size of pump vary with the viscosity and the rotative speed and may or may not be affected by pressure, depending upon the type and

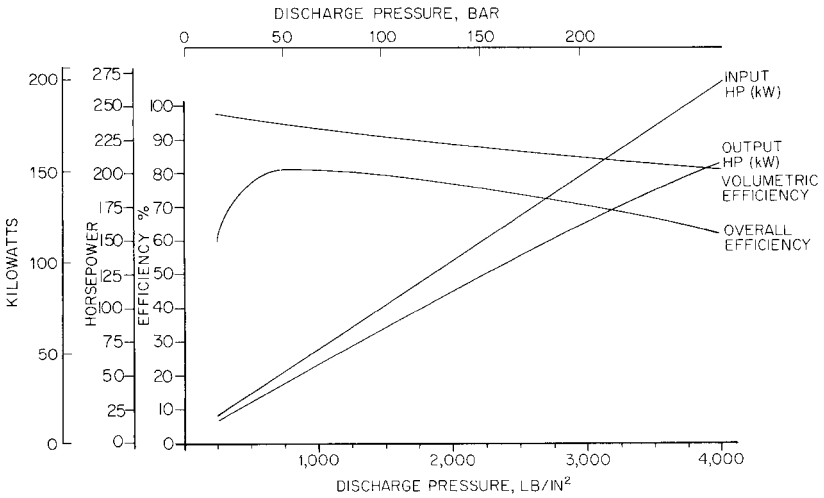


FIGURE 19 Typical overall efficiency curves.

model of pump under consideration. These losses, however, must always be based upon the maximum viscosity to be handled since they will be highest at this point.

The actual pump power output,  $whp$  ( $wkW$ ), or the delivered liquid horsepower (kilowatts), is the power imparted to the liquid by the pump at the outlet. It is computed similarly to theoretical liquid horsepower (kilowatts) using  $Q$  in place of  $Q_t$ . Hence, the value will always be less. The pump efficiency  $E_p$  is the ratio of the pump power output to the brake horsepower (see Figure 19).

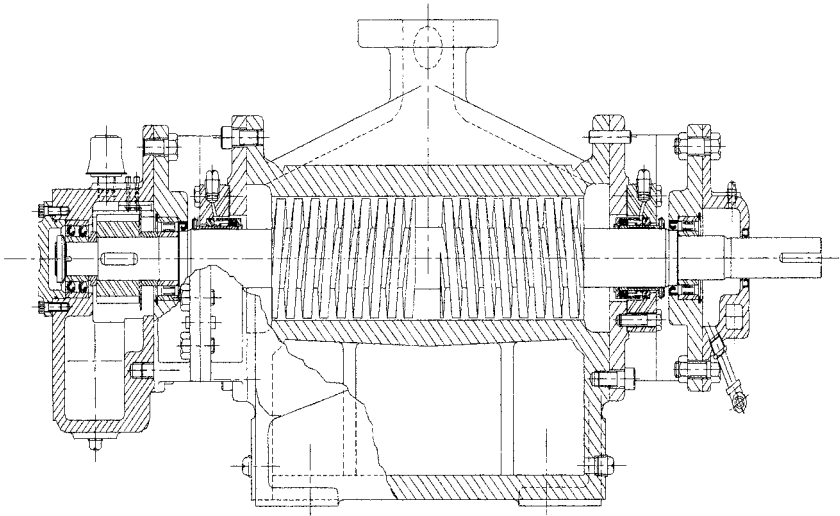
### SPECIAL MULTIPHASE APPLICATIONS

Screw pumps have been used with gas-entrained applications for many years, but recent process changes in oil field technologies have created requirements for pumping multiphase fluids, containing more than just nominal amounts of gases. In many oil well applications, the liquid oil flow eventually degenerates into all sorts of difficult multiphase mixtures of oil, gas, water, and sand. In the past, it was common for the gas to be separated and flared off at the well head with only the liquid product to be retained for further processing. If the gas is to be processed as well, separators, compressors, and dual pipelines are required to handle the gas phase. Therefore, a pump, which can handle these difficult liquids with high gas content, can save significant equipment costs as well as operating costs. Under various conditions, the well output can vary from 100 percent liquid to 100 percent gas and all possible combinations. The applications also require the pumping equipment to be able to switch rapidly between the extremes or to handle slugs of liquid or gas, while maintaining the full discharge pressure. The timed two-screw type of pump has proven capable of pumping these multiphase products.<sup>1</sup>

Oil well applications can include traditional on-shore sites as well as off-shore platform installations. Subsea installations are also being used to reduce the high costs of equipment and operation of traditional oil platforms. In these applications, the pumping equipment is mounted on the sea bed with piping running to on-shore gathering facilities. Although the actual pumping conditions are similar to surface installations, the installation and operating environments are far more challenging.

When pumping multiphase products with high *gas void fractions* (GVF), the pump must be designed with a small pitch to provide a sufficient number of locks. The key to





**FIGURE 20** Special screw pump for multiphase applications. (Flowsolve Corporation)

pumping multiphase products is to ensure that some liquid is always available to seal the screw clearances and reduce the slip. Even a small amount of recirculated liquid is sufficient to provide this seal and enable the screw pump to operate with GVF's approaching 100 percent. Depending on a number of factors, the volume of liquid required to seal and cool the screws can be three to six percent of the total inlet volume flow rate. In order to ensure that sufficient liquid is available at conditions of high GVF's, a separate liquid flush can be provided or a separator type of pump body can be used. This type of body includes a special chamber that can separate some liquid from the multiphase mixture being pumped. This liquid can be recirculated back to the screws and mechanical seals to provide sealing and cooling liquid at times when the product is almost all gas. Figure 20 shows a special screw pump designed for multiphase applications with a separating chamber built into the body.<sup>2</sup>

When pumping liquids, the slip through the internal clearances is proportional to the differential pressure and inversely proportional to the viscosity. However, in multiphase applications, as the GVF increases, the slip decreases until the inlet volume flow rate is equal to the pump displacement. This results in an almost constant inlet volume flow rate, regardless of the differential pressure. This performance can be explained by examining the pressure drop of the multiphase product across the finite clearances. This theoretical analysis confirms that a small amount of liquid in the clearances will effectively seal these clearances and reduce the slip to near zero. Figure 21 shows the typical performance characteristics for a screw pump in a multiphase application when pumping mixtures of air and water at various GVF values.<sup>3</sup>

It should be emphasized that screw pumps must be sized for the inlet volume conditions. Since the gas portion of the multiphase product is compressible, the inlet pressure and temperature conditions must be known in order to calculate the gas volume. The pump will ingest a fixed volume of product and the amount of liquid being pumped will depend on how much of this volume is being displaced by gas at the inlet to the screws.

The newest area of application for multiphase pumps is subsea. With special modifications, the rotary screw multiphase pumps can be coupled to submersible motors and mounted on the sea bed, instead of on surface platforms. The idea of pumping multiphase products directly from a subsea well head to shore facilities by means of submersible multiphase pumps has significant potential savings in separating equipment and platforms.<sup>4</sup> Figure 22

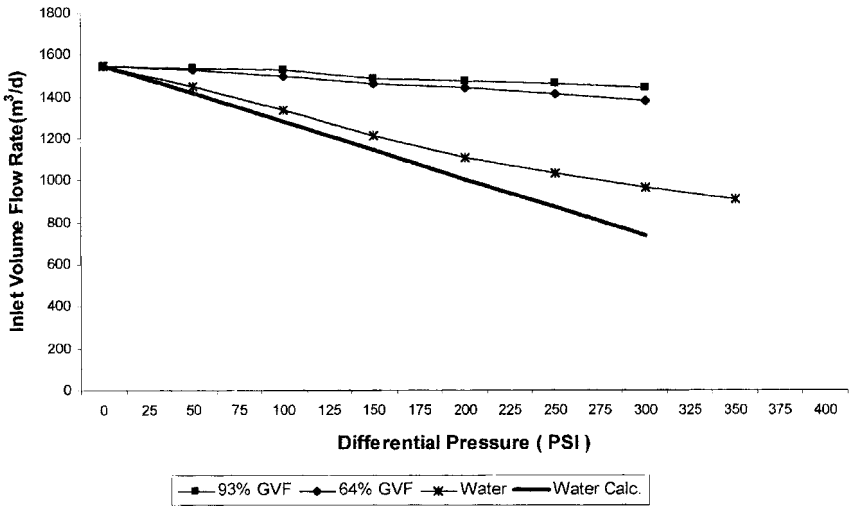


FIGURE 21 Typical performance of a screw pump on multiphase products (bar = psi/14.504).

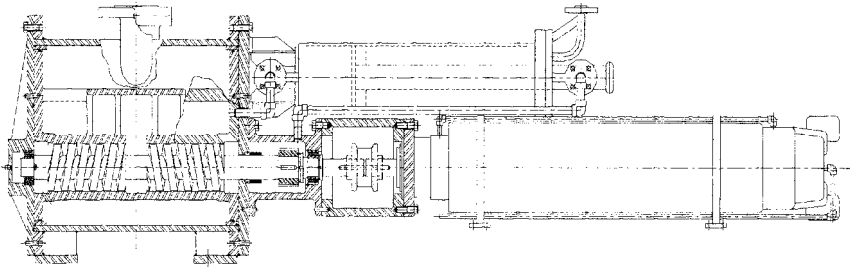


FIGURE 22 Multiphase screw pump for subsea application.

shows a special, timed, two-screw pump, configured for subsea multiphase applications, with special, product-lubricated outboard bearings and pressure-compensated, lube oil chambers.

## INSTALLATION AND OPERATION

Rotary pump performance and life can be improved by following the recommendations on installation and operation outlined in this section.

**Pipe Size** Resistance to the flow usually consists of differences in elevation, fixed resistances or restrictions such as orifices, and pipe friction. Nothing can be done about the first, since this is the basic reason for using a pump. Something can be done, however, about restrictions and pipe friction. Significant amounts of money can be wasted because of piping that is too small for the job. Certainly, not all pipe friction can be eliminated as long as fluids must be handled in this manner; but every effort should be made to use the largest pipe that is economically feasible. Numerous tables are available for calculating frictional losses in any combination of piping. Among the most recent are the tables in the

*Hydraulic Institute Engineering Data Book* (Reference 5) along with other similar hydraulic engineering references.

Before any new installation is made, the cost of larger-size piping, which will result in lower pump pressures, should be carefully balanced against the cost of a less expensive pump, a smaller motor, and a savings in power over the expected life of the system. The larger piping may cost a little more in the beginning, but the ultimate savings in power will often substantially offset the original cost. These facts are particularly true for extremely viscous fluids.

**Foundation and Alignment** The pump should be mounted on a smooth, solid foundation readily accessible for inspection and repair. It is essential that the driver shaft and the pump shaft are in proper alignment. The manufacturer's recommendation of concentricity and parallelism should always be followed and checked occasionally.

The suction pipe should be as short and straight as possible with all joints airtight. It should not contain places where air or other entrapped gases may collect. If it is not possible to have the fluid flow to the pump under gravity, a foot or check valve should be installed at the end of the suction line or as far from the pump as possible. All piping should be independently supported to avoid strains on the pump casing.

**Start-Up** A priming connection should be provided on the suction side, and a relief valve should be set from five to ten percent above the maximum working pressure on the discharge side. Under normal operating conditions with completely tight inlet lines and wetted pumping elements, a screw pump is self-priming. Starting the unit may involve simply opening the pump suction and discharge valves and starting the motor. It is always advisable to prime the unit before the initial startup to wet the screws. In new installations, the system may be full of air, which must be removed. If this air is not removed, the performance of the unit will be erratic, and, in certain cases, air in the system can prevent the unit from pumping. Priming the pump should preferably consist of filling not only the pump with fluid but as much of the suction line as possible.

The discharge side of the pump should be vented at startup. Venting is especially essential when the suction line is long or when the pump is initially discharging against the system pressure.

If the pump does not show a discharge of liquid after being started, the unit should be shut down immediately. The pump should then be primed and tried again. If it still does not pick up fluid promptly, there may be a leak in the suction pipe, or the trouble may be traceable to an excessive suction lift from an obstruction, throttled valve, or another cause. Attaching a gage to the suction pipe at the pump will help locate the trouble.

Once the screw pump is in service, it should continue to operate satisfactorily with practically no attention other than an occasional inspection of the mechanical seal or packing for excessive leakage and a periodic check to be certain that the alignment is maintained within reasonable limits.

**Noisy Operation** Should the pump develop noise after satisfactory operation, this is usually indicative of an excessive suction lift resulting from cold liquid, air in the liquid, misalignment of the coupling, or, in the case of an old pump, excessive wear.

**Shutdown** Whenever the unit is shut down, if the operation of the system permits, both the suction and discharge valves should be closed. This is particularly important if the shutdown is for an extended period because leakage in the foot valve, if the main supply is below the pump elevation, could drain the oil from the unit and necessitate repriming as in the initial starting of the system.

**Abrasives** One other point has not yet been discussed, and this is the handling of liquids containing abrasives. Since screw pumps depend upon close clearances for proper pumping action, the handling of abrasive fluids usually causes rapid wear. Much progress has been made in the use of harder and more abrasive-resistant materials for the pumping elements so that a good job can be done in some instances. It cannot be said, however,

that performance is always satisfactory when handling liquids laden excessively with abrasive materials. On the whole, screw pumps should not be used for handling fluids of this character unless a shortened pump life and an increased frequency of replacements are acceptable. In these cases, reducing the operating speed can maximize the operating life of the pump.

### CONCLUDING REMARKS

---

As indicated, screw pumps are manufactured in a number of different configurations and designs to suit a variety of different applications. Generally, screw pumps should be considered if there is a requirement for high pressure, high viscosity, or low hydraulic pulsation levels. Screw pumps can be used with lubricating and non-lubricating products and on many special and difficult applications. The keys to the success of screw pump applications include accurate knowledge of the fluid characteristics, proper pump selection and sizing, correct system design, suitable installation conditions, and the proper operating and maintenance procedures.

### REFERENCES

---

1. Vetter, G., and others. Tutorial: "Multiphase Pumping with Twin-Screw Pumps—Understand and Model Hydrodynamics and Hydroabrasive Wear." *Proceedings of the 17th International Pump Users Symposium*, Texas A&M University, College Station TX, March 2000, pp. 153–169.
2. Prang, A. "Selecting Multiphase Pumps." *Chemical Engineering*, February 1997, pp. 74–79.
3. Vetter, G., and Wincek, M. "Performance Prediction of Twin Screw Pumps for Two-Phase Gas/Liquid Flow." *Pumping Machinery—1993*, FED-Vol. 154, ASME, 1993, pp. 331–340.
4. Cooper, P., Prang, A. J., and Thamsen, P. U. "Applying Multiphase Pumps Subsea." *Proceedings of the Seventh European Congress on Fluid Machinery*, Institution of Mechanical Engineers, London, Paper No. C556/006/99, April 1999.
5. *Hydraulic Institute Engineering Data Book*, 2nd Edition, 1990, Hydraulic Institute, Parsippany, NJ [www.pumps.org](http://www.pumps.org).

---

# SECTION 3.8

---

# VANE, GEAR, AND LOBE PUMPS

---

ROBERT A. PLATT  
C. W. LITTLE, JR.

## DEFINITIONS AND NOMENCLATURE

---

Vane, gear, and lobe pumps are positive displacement rotary pumps. The Hydraulic Institute defines them as mechanisms consisting of a casing with closely fitted vanes, gears, cams, or lobes that provide a means for conveying a fluid. Their principle motion is rotating, rather than reciprocating, and they displace a finite volume of fluid with each shaft revolution. When describing them, the general term *fluid* is used, rather than the more restrictive *liquid*. Fluid, in this case, is understood to include not only true liquids, but mixtures of liquids, gases, vapors, slurries, and solids in suspension as well.

**How They Work** Pumping in a vane, gear, or lobe pump begins with the rotating and stationary parts of the pump defining a given volume or cavity of fluid enclosure. This enclosure is initially open to the pump inlet but sealed from the pump outlet and expands as the pump rotates. As rotation continues, the volume progresses through the pump to a point where it is no longer open to the pump inlet but not yet open to the pump outlet. It is in this intermediate stage where the pumping volume or cavity is completely formed.

Depending on the particular pump, there can be more than one cavity in existence at any one time. As this happens, fluid also fills the clearances between the pumping elements and pump body, forming a seal and lubricating the pumping elements as they in turn pump the fluid. Rotation continues and the cavities progress, moving fluid along the way. Soon a point is reached where the seal between the captured fluid volume and outlet part of the pump is breached. At this point the vanes, gears, or lobes force the volume of captured fluid out of the pump. While this is happening, other cavities are simultaneously opening at the inlet port to receive more fluid in a continual progression from suction to discharge ports.

For optimum pumping action, the *open-to-inlet* (OTI) volume should expand slowly and continuously with pump rotation. The *closed-to-inlet-and-outlet* (CTIO) pumping cavity volume should remain constant once it is formed, and the *open-to-outlet* (OTO) volume

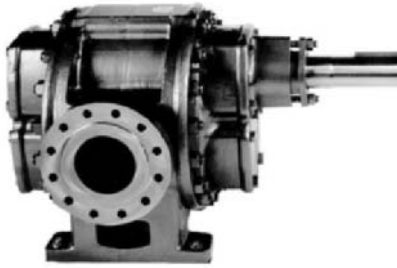


FIGURE 1 A typical rotary gear pump

should expand slowly and continuously with pump rotation. At no time should any fluid in the pumping chambers be simultaneously open to both the inlet and outlet if the pump is truly a positive displacement pump. When these conditions are met, the result is a very smooth continuum of flow with minimal pulsations or pressure spikes.

With rotary pumps (see Figure 1), a driver turns one shaft and rotor assembly, which in turn physically meshes with another to form the cavities that move the fluid. This is known as an *untimed arrangement*. For some applications, however, there would be problems with the gears, lobes, or screws meshing this way. For instance, stainless steel gears will gall and seize if rubbed against each other. High wear rates will also occur if any dirt is trapped between the meshing lobes of a lobe pump, regardless of their material, or if a pump with meshing gears is run dry.

To circumvent this, the timed pump was developed. It uses timing gears physically located outside the pumping chamber to transmit torque between the pump shafts and synchronize the pumping elements relative to each other. By preventing them from contacting each other, they eliminate many of the problems of dirty fluids, material compatibility, and dry running. Most lobe pumps are built this way, and gear pumps can be timed or untimed as well.

In some special cases, pressure-balancing designs, relief valve arrangements, or other such considerations have led to some designs where the pump can only operate in one direction. However, the principle of operation of most rotary pumps permits them to operate equally well in either direction.

**Main Components** The pumping chamber of a rotary pump is the area containing the pumped fluid while the pump is operating. Fluid enters the pumping chamber through one or more inlet ports and leaves through one or more outlet ports. The body is that part of the pump that surrounds the boundaries of the pumping chamber and is also referred to as a *casing*, *housing*, or *stator*. *End plates* can either be part of the body or separate parts, and they serve to close off the ends of the body to form the pumping chamber. End plates can also be referred to as *pump covers*.

The rotating assembly generally refers to all those parts that rotate when the pump is operating. *Rotors* are usually given more descriptive names, depending on the specific pump type. All rotary pumps employ a drive shaft to accept driving torque from the pump driver. The majority of rotary pumps are mechanically coupled to their driver with various types of couplings, but sealless magnetically driven pumps have become more common in recent years.

The cavity through which the drive shaft protrudes is called the *seal chamber*, and leakage through it is controlled by a *mechanical seal* or *packing*. In a mechanical seal, two faces with opposing axial loads are maintained in close contact with each other. When compressible packing and a stuffing box are used in place of a mechanical seal and seal chamber, the packing is compressed in the stuffing box by a gland that keeps it in intimate contact with the stationary and rotating elements. A *lantern ring* or *seal cage* is often placed between two of the packing rings to enable cooling and lubrication from an external source.

A number of other auxiliary devices and arrangements can be found in vane, gear, and lobe pumps, but two are especially characteristic of these pump types. Given the positive displacing nature of these pumps, and the potentially high pressures that can result at the outlet of the pump if there is an obstruction or blockage, *safety relief valves* must be used with all positive displacement pumps. They limit the pressure by opening an auxiliary passage at a predetermined set pressure and relieving flow back to the inlet side of the pump or to the fluid's original source. They can be installed externally or serve as an integral part of the pump. One exception is flexible member pumps, which, by the nature of their design, usually do not require one, due to the resiliency and expandability of their elastomeric components.

Nonetheless, most rotary pumps are available with integral relief valves. Although these devices are a necessary investment for safety, they are not a substitute for an external system relief valve. They are a secondary safety device at best and are not intended for continuous duty, flow control, or system pressure modulation.

To reduce fluid viscosity in the pump body to facilitate a successful startup and maintain event-free operation, *heating jackets* are used. They can be either integral to the pump (either welded on or part of the body casting) or a separate bolt-on type. They are common with asphalt, gelatins, paraffin, molasses, greases, and similar fluids where, without heating, the power and torque required to drive the pump could easily overload the driver. If viscous enough, a cold startup could actually destroy the mechanical seal, shear a shaft coupling, break a drive shaft, or cause damage to the equipment some other way. Heating jackets are not intended to be the main source of heating in the system. If the system requires the fluid to be heated, some other means, such as heat tracing the system piping, must be used.

**Materials of Construction** When selecting materials for rotary pumps, consideration must be given to the following material properties:

- The modulus of elasticity (for deformation purposes)
- The coefficient of thermal expansion (for varying temperatures)
- The coefficient of friction (for resistance to galling when in sliding contact)

For rotary pumps with flexible members, further consideration must be given to the materials' bulk modulus for recovery from deformation.

The close running clearances of rotary pumps require that their materials resist deformation and deflection by the various forces present when the pump is operating. If they do not, then such deformation or deflection could open the clearances and lower the operating efficiency dramatically or close the clearances and cause high mechanical loading and seizing between the moving and stationary parts.

The materials must also have compatible coefficients of thermal expansion. With the potential for deflection of the rotating parts always present, the materials selected must also have good bearing characteristics to resist galling up to the point of a compressive yield of the mating materials. This is especially important when pumping low-lubricity fluids.

Furthermore, materials used for corrosion resistance in non-contacting surfaces of centrifugal pumps may be unusable in rotary pumps where the continuous sliding contact between parts can wear away their passivating or protective layers. In general, rotary material restrictions become more severe when handling low-viscosity fluids at higher pressures and/or low lubricity fluids with abrasives. In addition, even where there is no load-bearing contact between the rotating and stationary parts under normal conditions, the high transient forces generated at startup, shutdown, or any other unusual operating conditions (such as cavitation) must be considered when selecting pump materials.

The performance of flexible member pumps heavily depends on the material of the flexible member. Its bulk modulus must be high enough to keep distortion under pressure within functional limits and it must be resilient enough to spring back to its original shape after flexing or compressing. For instance, if, once deflected, the vanes in a flexible vane pump stayed that way, the pump could no longer operate. That is, these materials must be

chosen not only to satisfy the desired hydraulic conditions, but also for resistance to deterioration from fatigue, chemicals, and the temperatures to which they may be exposed.

**Vane Pumps** Two basic types of vane pumps exist. The most common is the rigid sliding metal vane type, and the other is the flexible or elastomeric vane used for dirty or chemically aggressive fluids. Both are based around external sliding vanes rotating about a non-concentric cam.

All rigid vane pumps have moveable sealing elements in the form of non-flexing blades, rollers, buckets, scoops, and so on. These elements move radially inward and outward by cam surfaces to maintain a fluid seal between the OTI and OTO sectors during pump operation. When the cam surface is internal to the pump body and the vanes are mounted in or on the rotor, the pump is called an *internal vane pump*. The OTI volume is defined by the body walls, the rotor walls, the fluid seal contact between the vanes, and the body. The body wall surface, the rotor surfaces, and the vane-to-rotor and vane-to-body fluid seal points define the CTIO volume. The body surface, the rotor surface, the vane-to-body fluid seal points, and the vane-to-rotor fluid seal points define the OTO volume.

In internal vane pumps, the volume behind the vanes must always be either a composite constant volume or else be vented, because of the piston-like pumping action of the vanes on the fluids trapped there. However, no such venting is required when the vanes are in the form of rocking slippers.

When the cam surface is external to the radial surface of the rotor and the vane, or the vanes are mounted in the body or stator, the pump is called an *external vane pump* and is illustrated in Figure 2. The OTI, CTIO, and OTO volumes are defined the same as for internal vane pumps when multiple external vanes are used. In this case, the rotor surface, the body surface, and the fluid seal points between them define the CTIO volume.

In addition to rigid, sliding metal vane pumps, flexible or elastomeric vane type pumps also exist. This kind of pump, illustrated in Figure 3, has a pumping action similar to that of an internal vane pump with the OTI, CTIO, and OTO volumes defined by the rotor surfaces, the body surfaces, the fluid seal contacts between the rotor flexible vanes, and the body surfaces.

The flexible liner pump in Figure 4 is similar in pumping action to the external vane pump, and all three chamber volumes of it are defined by the inner surface of the body, the outer surface of the liner, and the liquid seal contact between the liner and body bore. Most flexible liner pumps, unlike other rotary pumps, have at least one position of the rotor in which no fluid seal exists between the OTI and OTO volumes. The pump depends only on fluid velocity and inertia to limit backflow during this phase of rotation.

Vane pumps offer flows at up to 1,000 gpm (3,785 l/min) and pressures at up to 125 lb/in<sup>2</sup> (8.6 bar). They are commonly used for low-pressure transfers of gasoline, kerosene, and similar light hydrocarbons.

**Gear Pumps** Evidenced by drawings dating back to the 16th century, the gear pump is one of the oldest pumps of any type. It is also the most common of all rotary pumps due to the wide variety of applications it can be used in.

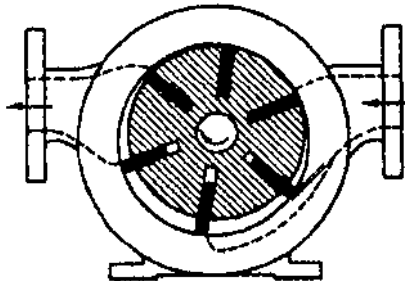


FIGURE 2 A typical external vane pump



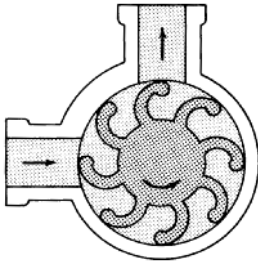


FIGURE 3 Flexible vane pump

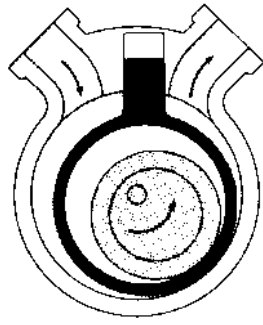


FIGURE 4 Flexible liner pump

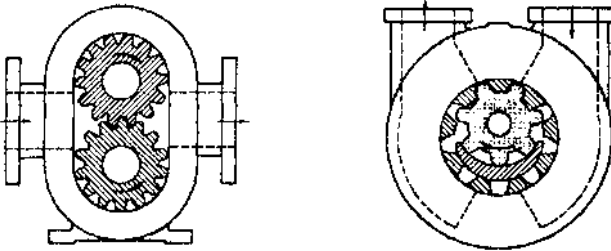


FIGURE 5 A typical external (left) and internal (right) gear pump

Gear pumps have two gears that mesh to provide its pumping action, with one gear driving the other. The physical contact between the gears forms a part of the moving fluid seal between the inlet and outlet ports. The outer radial tips of the gears and the sides of the gears form part of the moving fluid seal between the inlet and outlet ports. The gear contact locus moves along the tooth surfaces and jumps discontinuously from tooth to tooth as the gears mesh and unmesh during rotation. These two characteristics distinguish gear pumps from lobe pumps where the rotors (lobes) are incapable of driving each other and the fluid seal contact locus between lobes moves continuously across all the radial surfaces of the lobes.

Gear pumps are classified as *external* or *internal* (see Figure 5), and external gear pumps can be either *timed* or *untimed*. External gear pumps have their gear teeth cut on their external or outside diameter and mesh about their outside diameters. Bearings support the shafts at both ends with the gears located between the bearings. This resists shaft deflection and contact between the gears and casing wall, enabling the pump to operate at higher pressures and with less overall wear over time than would otherwise be possible.

Internal gear pumps, on the other hand, have one larger gear (rotor) with gear teeth cut internally on the major diameter meshing with and driving a smaller externally cut gear (idler). Pumps of this type can be with or without a crescent-shaped partition to define the OIT, CTIO, and OTO zones.

The OTI volume of the pump chamber in gear pumps is defined by the body walls and by where each tooth tip meets and seals with the body walls as it leaves the OTI volume. The fluid trapped between the gear teeth and the body walls is sealed from both inlet and outlet chambers and is the CTIO volume. The OTO volume is defined by the body walls and the gear tooth surfaces between the fluid seal points where each tooth tip leaves the body wall and enters the OTO volume and fluid seal points where the gears mesh.

A part or all of the side (or axial) surfaces of the gears run in small-clearance contact with the axial end faces of the pumping chamber. The gear teeth run in small-clearance

contact with each other where they mesh. The tips run in small-clearance contact with the radial surfaces of the pumping chambers in their travel from the OTI to OTO volume. Load-bearing contact between the rotors or between the rotors and the stator may exist in all three of these zones, and the apertures defined by the running clearances in these zones determine the amount of slip between the OTO and OTI volumes for any given pressure difference and viscosity between them.

Both gears share pumping torque, and the proportional amount of the total torque experienced by each gear at any instant is determined by the locus of the fluid seal point between the gear teeth. As this fluid seal point moves toward the center of gear rotation, the pumping torque on that gear increases, and as the seal point moves away from the center, the torque decreases. When external timing gears are used, they transfer torque from one rotating assembly to another to safeguard against accelerated wear when dry running or handling low-lubricity or abrasive fluids.

A special form of gear pump illustrated in Figure 6 is known as a *screw-and-wheel pump*. The driving gear is helical, and the driven gear is a special form of a spur gear. The helical gear always is the driving, or power, rotor in this type of pump, and external timing gears are not used. The pumping torque in the screw-and-wheel pump is felt both by the screw and by the wheel, and the amount of torque felt by each is determined by the fluid seal contact locus points between the two rotors. As in other gear pumps, the running clearances between the rotors and between the rotors and the body walls determine leakage from the OTO volume to the OTI volume.

External gear pumps are capable of flows up to 1,500 gpm (5,680 l/min), pressures up to 500 lb/in<sup>2</sup> (34.5 bar), and viscosities up to 1,000,000 SSU (216,000 centistokes). They are found in both clean and dirty services serving the *original equipment manufacturer* (OEM), refinery, tank farm, marine, and API-related industries. Internal gear pumps are capable of flows up to 1,100 gpm (4,165 l/min), pressures up to 225 lb/in<sup>2</sup> (15.5 bar), and viscosities up to 1,000,000 SSU (216,000 centistokes). They are typically used for lower pressure transfers of fuel oils, paints, and various chemicals in the chemical processing and OEM industries.

**Lobe Pumps** The lobe pump receives its name from the rounded shape of the rotor radial surfaces that permits the rotors to be continuously in contact with each other as they rotate. Lobe pumps can be either single- or multiple-lobe pumps and carry fluid between their rotor lobes much in the same way a gear pump does.

Unlike gear pumps, however, neither the number of lobes nor their shape permits one rotor to drive the other, and so all true lobe pumps require timing gears. The body surfaces, rotor surfaces, the contact between rotors, and the contact between rotor lobe ends and the pump body define the OTI volume of a pump. The contact between the lobe ends and the body wall and the adjoining body wall and lobe surfaces define the CTIO volume. The body walls, rotor surfaces, lobe-to-body wall contacts, and the lobe-to-lobe contacts define the OTO volume.

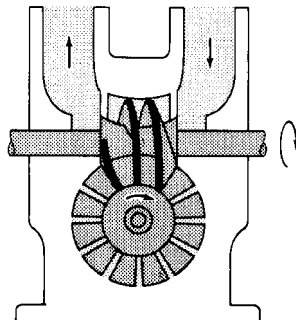


FIGURE 6 A typical screw-and-wheel pump



FIGURE 7 Typical single-lobe (left) and multiple-lobe (right) pumps

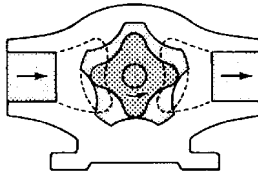


FIGURE 8 A typical internal gear, or internal lobe, pump

In the two-rotor lobe pumps shown in Figure 7, the torque is shared by both rotors with the proportional amount of torque dependent on the position of the rotor-to-rotor contact point on the rotor contact locus. When the contact point is at the major locus radius (maximum lobe radius of one rotor in contact with the minimum lobe radius of an adjoining rotor), one rotor sees the full pumping torque, while the other rotor feels a balanced torque. The transfer of a full pumping torque from one rotor to the other takes place as many times in each complete revolution of a rotor as there are lobes on the rotor.

An internal lobe, or *gerotor* pump, is shown in Figure 8 and has a single rotor with a lobe-like peripheral shape. It moves in a combination of rotations and gyrations about its center of rotation in a body with internal, lobe-shaped contours in such a way that the rotor always touches the body at two or more locations to preserve the fluid seal between OTI and OTO volumes. The outer rotor surface, inner body surface, and the fluid seal points between them define the OTI volume. The outer rotor surface and the inner body surface between two adjacent fluid seal points define the CTIO volume. The outer rotor surface, inner body surface, and the rotor-to-body fluid sealing points define the OTO volume.

Most pumps of this type have one fewer rotor lobe than an internal body lobe cavity and the term *progressing tooth gear pump* is sometimes used. The full pumping torque is seen by the single rotor, but the torque is cyclic. It is a function of the position of the rotor and its sealing arrangement with the pump body, while the number of torque cycles per rotor revolution is equal to the number of lobes on the rotor.

Lobe pumps are capable of flows up to about 1,000 gpm (3,785 l/min) and pressures up to 125 lb/in<sup>2</sup> (8.6 bar). They are commonly used to pump sludge in wastewater treatment plants and in stainless steel systems for handling foodstuffs in the food, beverage, dairy, and pharmaceutical industries.

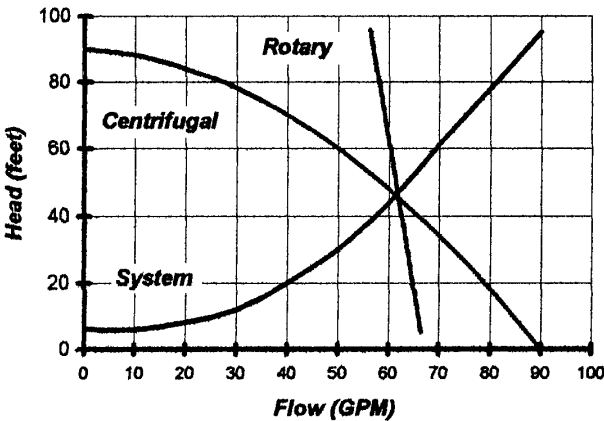
A summary of the main application advantages of vane, gear, and lobe pumps is shown in Table 1.

### COMPARISONS TO CENTRIFUGAL PUMPS

A rotary pump uses mechanical and hydraulic forces to create a flow against a system backpressure. Centrifugal pumps, on the other hand, create pressure by imparting a velocity to the fluid and converting the velocity energy to a pressure energy as the fluid flows

**TABLE 1** Summary of vane, gear and lobe pump attributes

Application Advantages			
Vane	Gear (External)	Gear (Internal)	Lobe
<ul style="list-style-type: none"> <li>• Can handle viscosities under 32 SSU</li> <li>• Self compensating for wear</li> <li>• Available in a variety of materials</li> <li>• Inexpensive</li> </ul>	<ul style="list-style-type: none"> <li>• Can handle high viscosities</li> <li>• High flows and pressures</li> <li>• Between-the-bearing design prolongs life.</li> <li>• Quiet running</li> <li>• Integral relief valve available</li> </ul>	<ul style="list-style-type: none"> <li>• Can handle high viscosities</li> <li>• Available in a wide variety of materials</li> <li>• Simple, inexpensive design</li> <li>• Integral relief valve available</li> </ul>	<ul style="list-style-type: none"> <li>• Can handle high viscosities</li> <li>• Low shear pumping</li> <li>• Available in a variety of materials</li> <li>• Can run dry if seals are flushed (due to timing gears)</li> </ul>

**FIGURE 9** Typical performance curves ( $m = ft \times 0.3048$ ;  $m^3/h = gpm/4.403$ )

around the casing and out the discharge nozzle. A comparison of the resulting performance of these two different pump types is shown in Figure 9.

The conditions of service will usually determine the best pump for an application. For instance, for constant pressure at varying flow rates, a centrifugal pump would be a good choice. An example of this is a municipal water system where consistent pressure must be maintained over a wide range in usage levels. By contrast, for a constant flow in the presence of varying back pressures, a rotary pump would be better. An example of this is an oil pipeline, where system economics dictate constant flow rates, regardless of any system pressure variations from changes in viscosity or pipe diameter.

Other differences exist between centrifugal and rotary pumps as well. The performance curves, affinity laws, and terminology used to describe rotary pumps are all different. And since rotary pumps are primarily for viscous fluids, the applications and markets

served by these two pumps are also different. One of the few direct comparisons that can be made between centrifugal and rotary pumps is with single- versus multi-stage pumps. Even here though, the analogy is not a perfect one, and certain rotary pumps, such as progressing cavity pumps, fit the description better than others. Other factors, such as vertical versus horizontal mounting, metal versus non-metallic materials, sealless and magnetically driven versus dual-containment mechanical seals and conventional drivers, are similar whether considering a centrifugal or rotary pump.

**Rotary Pump Curves** Centrifugal pump curves plot the flow on the X-axis with the discharge head on the Y-axis. However, rotary pumps develop the flow against a system back-pressure, rather than developing head with a corresponding flow rate. Their performance curves therefore show the flow on the Y-axis with differential pressure along the X-axis, as shown in Figure 10.

The influence of differential pressure on the flow is greatest with lower viscosity. Since this represents the worst (least) case for flow, it is the point around which the flow rate is established. Conversely, the maximum viscosity represents the worst (most) case from a power standpoint and is therefore the point around which the driver is sized.

Other considerations, such as flat versus steep curves or matching a system curve to a pump curve, also cannot be applied to rotary pumps the way they can with a centrifugal

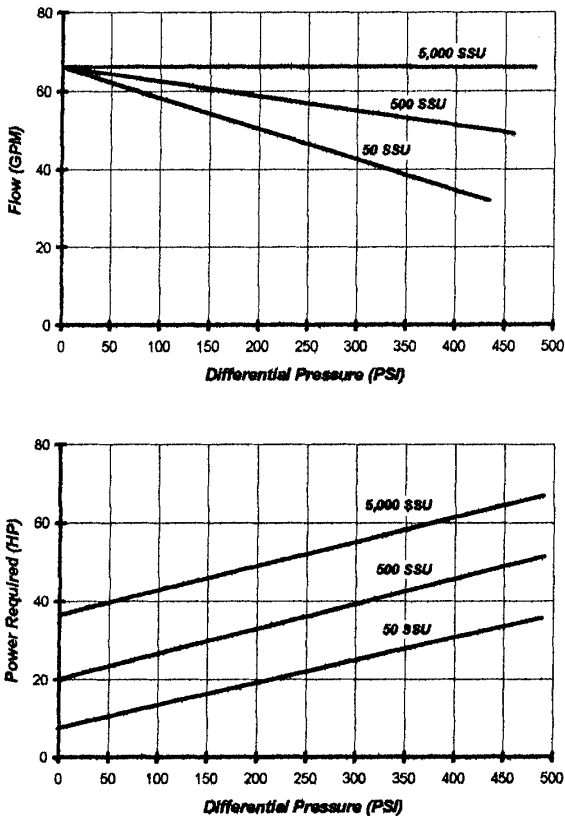


FIGURE 10 Typical rotary pump flow and power curves (bar = psi/14.5; kW = hp  $\times$  0.746; 50, 500, 5000 SSU = 7, 108, and 1080 centistokes respectively.)

pump. Instead, a rotary pump is selected for a given differential pressure and viscosity at the nearest commercially acceptable speed. For viscosities under 3,000 SSU (650 centistokes), this means at synchronous motor speeds with the flow rate falling at the design point or (ideally) slightly above it. For higher viscosities, rotary pumps will be run at reduced speeds, which in some cases can go well below 100 revolutions per minute (rpm).

**Performance with Viscous Fluids** Centrifugal pumps assume the absence of any appreciable viscous drag across the impeller shroud and vane surfaces when developing their pumping action. However, viscous drag, as the fluid passes across these surfaces, can be considerable with higher viscosities. With an increasing viscosity, an increasing amount of energy must be expended to overcome these forces and produce the same amount of hydraulic work. At some point, viscosity will simply overtake the centrifugal pump, and it can no longer overcome the inertia and viscous drag losses of the fluid. The effect of this can be seen in Figure 11.

Since rotary pumps do not work this way, they are better suited for high-viscosity fluids. Certain rotary pumps, such as twin screw pumps, can even go as high as 1,000,000 SSU (216,000 centistokes) without a significant deterioration of performance or efficiency. Compared to centrifugal pumps, rotary pumps are less efficient at lower viscosities but more efficient at higher viscosities. From an applications standpoint, this crossover point will vary from pump to pump and depends on many factors, but as a rule of thumb, it usually falls between 500 and 1,000 SSU (108 and 216 centistokes).

**Affinity Laws** Rotary pumps do not have a single *best efficiency point* (BEP) the way a centrifugal pump does, and no parallels for radial thrust loads exist as a function of the position on the curve relative to BEP the way there is with centrifugal pumps. Similarly, no rotary pump parameter is analogous to the specific speed ( $N_s$ ) of centrifugal pumps; although, an approximate  $N_s$ -domain into which rotary pumps fall can be identified (see Chapter 1 and Section 2.1). Instead, rotary pumps simply use the flow per revolution to make general comparisons. A summary of the basic rotary pump affinity laws is shown in Table 2.

## SYSTEM CONSIDERATIONS

The variety of applications and system conditions, including the vast number of fluids handled in rotary pump applications, precludes a comprehensive coverage in a handbook of this type. The best source for this information is the manufacturer of that particular pump type.

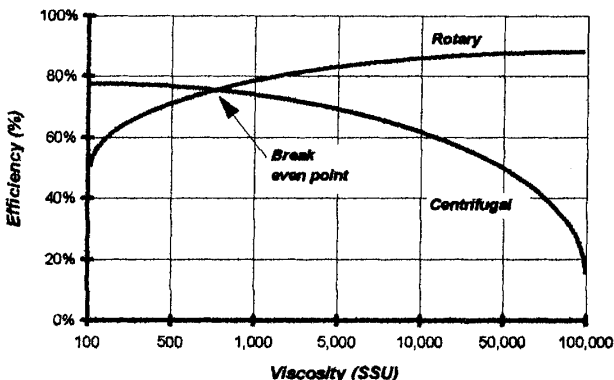


FIGURE 11 Typical efficiencies as a function of viscosity. (In this range, centistokes  $\approx$  SSU/5.)

**TABLE 2** The basic affinity laws for rotary pumps

Rotary Pump Affinity Laws For Speed		
	Speed Change	Corresponding Effect
	$\{RPM_2 / RPM_1\}$	$\{GPM_2 / GPM_1\}$
	$\{RPM_2 / RPM_1\}$	no direct effect on differential pressure
	$\{RPM_2 / RPM_1\}$	$\{BHP_2 / BHP_1\}$
	$\{RPM_2 / RPM_1\}$	$\{NPSH_2 / NPSH_1\}^X$ where $X$ varies from 1.5 to 2.5

**Mechanical Installation** All rotary pumps, particularly rigid rotor pumps, must be installed so no mechanical forces other than those imposed by pump-generated pressures can act to warp or distort the pump chamber or rotating assembly. This is important because relatively small distortions of a few thousandths of an inch can cause interference between rotating and stationary parts and generate high wear rates or pump damage.

To avoid such distortions, the pump must not be installed with overly long, rigid fittings or in such a way that the pump body supports the weight of the piping system. The problem of distortion of clearances in the pump chamber is not as severe for flexible member pumps, but large mechanical forces that distort the pump body may also cause distortions of the mechanical seals and accelerate wear of the bearings. A cardinal rule, then, is that a rotary pump must not be rigidly coupled to the piping system in a way that causes it to support the weight of the piping or otherwise exposes it to any forces from thermal expansion. Poor mechanical installation is the cause of many field problems.

**Dry Running** Most rotary pumps will be damaged if allowed to run dry. As long as the system provides a positive static pressure on fluid present at the inlet, the pump should prime and not run dry. If a negative inlet gage pressure, or suction lift, is present at the pump inlet, the installation should be checked to ensure airtight seals throughout the entire upstream piping.

The sealing arrangement on the pump must also be checked for any leakage of air or gas into the pump through the seal. If these conditions are satisfied, fluid will enter the pump soon after pump operation starts because of the vacuum generated by pump operation. If these conditions are not met, air or other gases will flow through leaks in the inlet system or seal to satisfy the pump flow rate requirements and the pump will run dry. One safeguard to ensure fluid at the pump inlet is to install a foot valve in the submerged portion of the inlet piping. Once primed, the foot valve will keep fluid in the pump and prevent it from running dry upon subsequent restarting.

**Suction Strainers** Like most other pumps, rotary pumps last longer when handling clean fluids. Nonetheless, this is an ideal scenario, and the pump will more realistically encounter dirty or abrasive-laden fluids of varying degrees. Fine particles and abrasives will cause wear in the close clearances of the pump, which eventually reduces pump flow rate by increasing the slip through the increased clearances.

As such, all rotary pumps should have a suction strainer to exclude larger materials such as welding slag, scale, rust, chips, rags, bolts, nuts, and so on. Since a suction strainer contributes to suction line losses, this reduces the net inlet pressure available. The finer the filtration, the greater the restriction and the more frequently it must be maintained. This leads to a trade-off between the cost of the added maintenance versus the cost of replacing the worn pump parts earlier than they would be otherwise.

When pumping fluids over 5,000 SSU (1080 centistokes), the finest strainer screen practical is a  $\frac{1}{16}$ -inch (1.5 mm) perforation. Strainers and filters not only require periodic maintenance, but should also be instrumented accordingly. It is important for the user to provide some means of monitoring, such as a differential pressure gauge or switch, since a clogged strainer will cause the pump to cavitate or even run dry.

**Entrained Air and Dissolved Gases** An important consideration with rotary pumps is the amount of entrained air or gas in the fluid. It is generally neglected, since a rotary pump cannot become vapor-bound the way a centrifugal pump can. Nonetheless, with entrained air present, there can be a perceived loss in the outlet flow. If the entrained air is a large enough percentage, there may be unacceptable noise and vibration levels as well.

For example, if a fluid contains five percent entrained gas by volume and the suction pressure is atmospheric, the mixture is 95 percent liquid and 5 percent gas. This mixture fills up the moving voids on the inlet side, with 5 percent of the space filled with gas and the remainder with liquid. Therefore, in terms of the amount of liquid handled, the output is reduced directly by the amount of gas present, or 5 percent. Unless this is understood up front, it could lead to a less than satisfactory output flow rate through no direct fault of the pump itself.

Entrained air is common in systems where the liquid is cycled frequently. In many cases, the foaming or air entrainment cannot be avoided, such as with the lubrication system on a large reduction gearbox. Instead, the condition must be known and well understood before selecting a pump for the application.

If dissolved gases (gases different than the fluid's own vapor) are present in the fluid, the effect on the output flow is the same as with entrained gases. This is because the dissolved gases will come out of solution when the pressure is lowered, just as the fluid's own vapor will. This will have the same net effect as the entrained gas and will occupy the available displacement capacity. Although the fluid mass transfer rate will not be affected, this is likely to be small comfort since the measured liquid displacement will be reduced.

**Noise** Pumps are often the most offensive noise sources in hydraulic machinery. High-pressure pulsations and heavily loaded sliding elements within the pump produce broadband, high-energy airborne noise. Vane, gear, and lobe pumps, however, are among the lowest noise producers of any fixed displacement-type pump. Flow is delivered continuously without the variations that produce noise in conventional hydraulic pumps. Pumping elements utilize a fluid film, reducing the sliding contact, and the visco-elastic properties of the fluids they pump help dampen whatever fluid-borne pressure pulsations are present. These design features are responsible for the wide use of these pumps wherever noise is critical. For instance, they are widely installed on die-casting machines, plastics equipment, presses, and an enormous variety of machine drives and machine tools.

**Inlet Pressure** The absolute pressure above the vapor pressure *available* at the pump inlet must always exceed the absolute pressure above the vapor pressure *required* by the pump. For rotary pumps, this pressure is determined by Hydraulic Institute standards similar to those used for centrifugal pumps.

Another consideration is the effect of a net negative total differential pressure. This can occur when there is a variable positive static pressure on the inlet that exceeds the discharge or outlet pressure. In this case, the flow slip reverses direction and actually adds



to the capacity of the pump, causing the total flow through the pump to be greater than the pump displacement capacity.

This can also occur with a stopped pump, and rotary pumps are not effective at stopping the flow through them. In applications where the flow cannot be permitted through an idle pump, or where inlet or outlet static pressure heads exist, valving in the system must be used to stop the flow. For example, in intermittent deliveries where the pump is "lifting" liquid from a source below its inlet without any valving in place to address this when the pump is stopped, the fluid will gradually drain backward through the pump and back to its source. This could create errors in measuring the amount of fluid transferred or cause the pump source (a holding tank) to overflow.

## FLUID CONSIDERATIONS

---

Very few commercially handled fluids are homogenous liquids. In actual systems, most fluids have air or other gases dissolved or entrained in them. In other cases, solids (abrasive or non-abrasive) may be in the fluid. The variety of fluids handled by rotary pumps requires that each pump application be uniquely considered in terms of the effects of the pumped fluid on pump performance. General summaries of the effects of various fluid characteristics on pump performance are covered in the following paragraphs.

**Temperature** The temperature of the pumped fluid affects pump performance in three main ways. If the pump is to handle fluid at temperatures considerably different from ambient ones, the materials of construction, both in the pump and in the seals, and the operating clearances of the pump must be selected to provide the desired operating characteristics at the temperature of operation. The selection process becomes even more stringent when the pump is operated over a wide range of temperatures. Such a use may preclude the use of pump construction materials having high thermal coefficients of expansion. Furthermore, in the actual application, it may be necessary to preheat or pre-cool the pump to the operating temperature before the pump is started in order to avoid thermal shocking the internal components when the fluid enters the pump. If this is not done, the resulting rapid heating or cooling of the pump members from the inside out can damage the pump. Preheating or pre-cooling can usually be accomplished with a secondary medium such as a heating jacket.

**Viscosity** Another effect of fluid temperature is on the viscosity of the fluid. For the majority of the commercial liquids, the viscosity increases with decreasing temperature and decreases with increasing temperature. If the pump application requires usage over a wide temperature range, the highest viscosity at this temperature range must be known to determine whether the pump is operating below the upper speed limit imposed by this fluid viscosity. The effects of viscosity on speed and the net inlet pressure (above the vapor pressure of the liquid) required is shown in Figure 12.

**Lubricity** Still another important fluid characteristic is lubricity. Many rotary pumps are not designed to operate on liquids with no lubricity. Either the wear rate or the pump mechanical friction may be inefficiently high if these pumps are used on non-lubricating fluids.

**Cavitation** The creation of vapors and the subsequent collapse of the vapor bubbles upon reaching the higher-pressure discharge side of the pump is known as *cavitation*. Cavitation forces the liquid into the vapor voids at high velocities and produces local pressure surges of high intensities impinging on the pump surfaces. These forces can exceed the tensile strength of the metal, eroding it in the process. Left uncorrected, cavitation can cause pitting of the vanes, gears, or lobes and interior casing walls; bearing failures; and even shaft breakage. In addition, cavitation causes noise, vibration, and a loss of output flow. The bigger the pump, the greater the noise and vibration can be.

Lowering the static suction lift of a system, increasing the suction pipe diameter, and simplifying the suction piping layout can reduce cavitation by raising the net inlet pressure

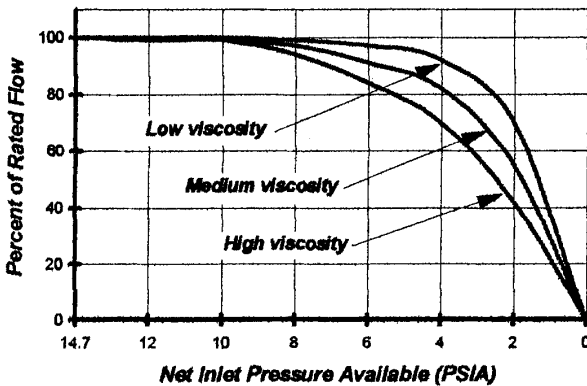


FIGURE 12 How viscosity and net inlet pressure available influence flow (bar = psi/14.5. Expressed as head of pumped liquid, the net inlet pressure is called *NPSH*.)

or *NPSH* available. In reality though, the net inlet pressure available is not something that can easily be altered. Instead, the pump vendor will usually be asked to select a pump with a lower net inlet pressure required. The best way to do this is to select a larger pump running slower. This will give the fluid more residence time to fill the void on the suction side, and with larger internal passages and ports, pump entry losses will be reduced as well.

**Non-Newtonian Fluids** The viscosity of most fluids is unaffected by agitation or shearing as long as the temperature remains constant. They are known as *true* or *Newtonian fluids*. Certain fluids, however, change viscosity as a shear is applied at a constant temperature. The viscosity of these fluids will depend upon the shear rate at which it is measured, and these fluids are termed *non-Newtonian*. Some examples are cellulose compounds, glues, greases, paints, starches, slurries, and candy compounds.

If a fluid is non-Newtonian, the viscosity under actual pumping conditions must be determined and can vary quite a bit from the viscosity under static conditions. An example is grease, where the static viscosity is around 20,000 SSU (4300 centistokes). Under actual pumping conditions, however, the viscosity is closer to 500 SSU (108 centistokes). Without realizing this, a larger, slower pump may have been offered when a smaller, less expensive pump running at a higher speed would have been acceptable.

Tests or computations should determine the effective fluid viscosity under actual operating conditions. If the pump is to operate over a range of speed and pressures, the maximum and minimum effective viscosities over this range should be known to allow for the additional slip or horsepower that may be required and to ensure the correct operating speed and pump driver power selections. If these data are unavailable, as is often the case, then data from a similar installation can be helpful. Ideally, the information will include the pump size, flow rate, and speed as well as the *NPSH* available and the pressure drop over a specific length of piping. With this information, assumptions can be made regarding the actual viscosity.

**Corrosiveness** Knowledge of the corrosiveness of the pumped fluid on the pump materials in contact with the fluid is important to satisfactory pump application. The clearances in rotary pumps are small, and corrosion rates of only a few thousandths of an inch per year may seriously affect the efficiency of the pump, particularly when it is handling low-viscosity fluids. In addition, general compatibility of the fluid with the materials of pump construction must be considered. For example, a certain solvent to be pumped may soften, dissolve, or destroy the elasticity of flexible members in the pump, including those flexible members used in the sealing arrangements. Hence, the effect of the pumped fluid on the physical and chemical state of materials used in pump construction should be considered when choosing a particular application.

**Abrasiveness** Abrasives present a problem for every pump type, and rotary pumps are no exception. With small operating clearances, the tendency of the abrasive is to wear down and open the tight clearances of the pump. Most rotary pumps' internal clearances are long, narrow, rectangular cross sections that can be modeled as two parallel flat plates, with one plate stationary and the other moving. These clearances range from essentially zero to a few thousandths of an inch. Thus, even minor variations in manufacturing tolerances or the effects of wear over time can cause considerable variations in the percentage change of the aperture volume. Also, the movement or deflection of movable elements in the pump, when exposed to pressure differences, can cause relatively large percentage changes in these clearances in different locations within the pump.

Because rotary pumps depend upon close clearances for their pumping action, whenever abrasive or dirty fluids are encountered, accelerated wear can be expected. Wear is difficult to predict because it depends on many variables that are difficult to measure (such as particle size, size distribution, or whether smooth or jagged shaped).

Classic theory tells us that laminar slip flow  $Q_s$  between two plates follows the general equation:

$$Q_s = k \left\{ \frac{P_d \times w \times d^3}{\nu \times l} \right\} \quad (1)$$

where  $Q_s$  = slip through the clearance, gpm ( $\text{m}^3/\text{hr}$ )

$k$  = a constant

$P_d$  = differential pressure,  $\text{lb}/\text{in}^2$  (bar)

$w$  = width of clearance, in (mm)

$d$  = clearance gap or depth, in (mm)

$\nu$  = absolute viscosity,  $\text{lb}\cdot\text{sec}/\text{ft}^2$  (centipoises) [Note: (absolute viscosity in centipoises) = (kinematic viscosity in centistokes)  $\times$  sp. gr.]

$l$  = length of clearance, in (mm)

Rotary pumps rely on close running clearances to seal between the suction and discharge pressures. This presents certain manufacturing trade-offs. For instance, the clearances must be tight enough to yield an acceptable volumetric efficiency with lower viscosities, yet large enough to facilitate internal lubrication with higher viscosities. For a given pump with a fixed viscosity and differential pressure, the slip flow is a function of the cube of the clearances only.

Unlike a centrifugal pump impeller, which can be trimmed to about 85 percent of its maximum diameter, rotary pump gears, screws, or lobes cannot be trimmed. As Figure 13 shows, up to a certain critical point, wear has little effect on the flow. Beyond this point, which varies from case to case, performance starts to deteriorate rapidly.

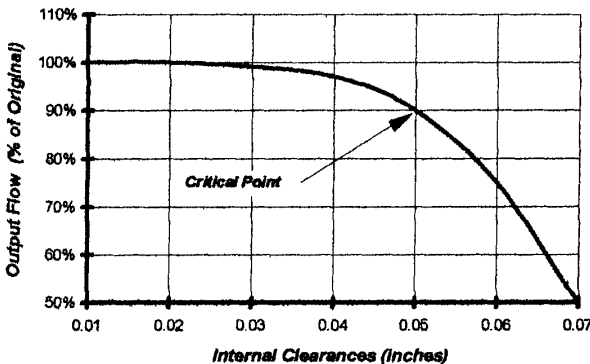


FIGURE 13 Output flow rate as a function of clearance size and wear

Much progress has been made in the use of harder and more abrasive-resistant materials for the pumping elements. However, rotary pumps should not be used for abrasive fluids, unless a decreased pump life and/or increased maintenance intervals are acceptable.

Other fluid characteristics could be important in the selection and application of vane, gear, and lobe pumps. Some liquids are sensitive to shear and must be handled in pumps with low shear rates. Others cannot tolerate exposure to the atmosphere, either because they can explode, crystallize, and damage the seal arrangement or otherwise interfere with the pump operation. Rotary pumps for these applications should have only static seals or multiple-section rotary seals with a protective liquid or gas in the seal zones between the fluid and outside atmosphere. In aseptic pumps, for example, stationary and moving seals can be designed with multiple seals to enable the use of steam under pressure as a sterile barrier between the pumping chamber and the atmosphere. Pumps in industrial applications where it could be dangerous if the fluid were exposed to the atmosphere may use multiple sealing arrangements with an inert liquid under pressure acting as a barrier between the pumping chamber and the outside atmosphere.

For the effective application of rotary pumps, the temperature, viscosity, lubricity, corrosiveness, and non-liquid content of the pumped fluid must be known, along with any special characteristics of the liquid, such as shear or atmospheric sensitivity. With these known, the proper pump type, seal arrangements, horsepower requirements, and speed can be determined.

**Vapor Pressure** A second effect of fluid temperature is on the vapor pressure of the fluid. Vapor pressure is the pressure that must be maintained at a given temperature to prevent the liquid from partially vaporizing into a gaseous state. Vapor pressure increases with temperature, and if the local pressure falls below the vapor pressure, vaporization and cavitation will occur.

Vapor pressure is particularly important when handling hydrocarbons and petrochemicals, which can have very high vapor pressures. For instance, low-sulfur crude oil vapor pressures can be as high as 100 lb/in<sup>2</sup> absolute (6.89 absolute) under summer ambient temperatures. Unless this is known when selecting a pump, the results could be a pump that works in cold weather but cavitates in warm weather.

## OPERATING CHARACTERISTICS

---

The operating characteristics covered in this section assume the fluid is a true incompressible liquid with a viscosity independent of the rate of shear (shear strain). Common fluids used in testing are either a light lubricating oil or cool water with small amounts of soluble oil added for lubricity.

**Displacement** The *theoretical or geometric displacement*  $Q_d$  of a rotary pump is the total gross fluid volume transferred from the OTI volume to the OTO per unit time. A standard unit of displacement is gallons per minute (cubic meters per hour). For any given pump, the displacement depends only upon the physical dimensions of the pump elements and the pump geometry and is independent of other operating conditions. In those pumps designed for variable displacement, the pump usually is rated at its maximum displacement.

**Slip** Flow slip,  $Q_s$ , is an important aspect of rotary pump performance. It is defined as that quantity of fluid that slips from the OTO volume to the OTI volume per the unit of time. Slip is a function of the clearances between the rotating and stationary members, the differential pressure between the OTO volume, the OTI volume, and the fluid viscosity. Hydraulically, it is equivalent to a bypass line from the pump outlet back to the inlet. The most common unit of measuring slip is U.S. gallons per minute (cubic meters per hour).

The major slip paths through the pump in the presence of a positive differential pressure are the clearances between the end faces of the rotors and the endplates of the pump cham-

ber, and those between the outer radial surfaces of the rotors and the inner radial surfaces of the chamber. The width, length, and height of the apertures formed vary considerably with different positions of the rotor as the drive shaft turns through a complete revolution. If the differential pressure across the pump remains constant during a revolution, then the instantaneous slip rate usually varies throughout the revolution. This variation in the slip is caused by the same effect that would be produced if the physical dimensions of the equivalent bypass around the pump were varied as a function of the angular rotation of the drive shaft. This is also one of the common causes of flow pulsation in rotary pumps. It is particularly dominant when pumping low-viscosity fluids at high pressures.

The average slip for any set of operating conditions can be found by measuring the flow rate from the outlet port (assuming an incompressible liquid) and subtracting that flow rate from the theoretical displacement flow rate  $Q_d$  that would otherwise be expected at those operating conditions. Most slip paths are constant in width but may vary in height with runout of the outside diameter of the rotors or wobble of the end faces of the rotors as they rotate. The paths can also vary considerably in length with the changing positions of the rotary and body-sealing surfaces during rotation.

The effect of pressure on the slip is complex. The primary effect is direct in that slip increases in direct proportion to pressure. However, several secondary effects should be considered as well. The first is the effect of pressure differences across the pump on the dimensions of the slip path. This occurs because of the deflection of pump elements as a function of pressure. This is relatively small in rigid element pumps but can be significant in flexible vane pumps where the pressure can cause the vanes to flatten out and move away from the body walls. In addition, while the slip may increase in flexible member pumps at high pressures, in rigid rotor pumps it can actually decrease as clearances close, due to the high-pressure deflection of the rotors.

Another secondary consideration is the indirect effect of pressure on the fluid velocity through the slip paths. At any given viscosity, the flow through these paths can have the characteristics of turbulent, laminar, or slug flows. The majority of practical applications would require that the slip be a minor percentage of the pump displacement. To remain so, the velocity of fluid flow through slip paths would normally be in the laminar flow region, and the slip would then be directly proportional to the pressure difference. A pressure increase could cause a change to turbulent flow and a corresponding change in the slip as a function of pressure.

Also, an indirect effect of pressure exists on the effective compression ratio of compressible fluids. The compression ratio reduces the amount of net volume flow through the outlet port relative to the displacement of the pump. Although not a true slip in the sense discussed up to this point, the type of slip caused by this effect reduces the net volume delivered through the outlet port and consequently affects the volumetric efficiency. This effect is a secondary effect in most liquids but can become a large component of the slip in aerated or compressible liquids. An increase in the compression ratio caused by an increase in the pressure difference causes an increase in slip from this effect.

**Flow Rate and Displacement** The flow rate or *capacity*  $Q_c$  of a rotary pump is the net quantity of fluid delivered by the pump per the unit of time through its outlet port or ports under any given operating condition. When the fluid is incompressible, the flow rate is numerically equal to the total volume of liquid displaced by the pump per the unit of time minus the slip, all expressed in the same units. When a rotary pump is operating with zero slip, the theoretical or geometrical displacement  $Q_d$  of the pump becomes the flow rate  $Q_c$ . A common unit of flow rate is U.S. gallons per minute (cubic meters per hour):

$$Q_c = Q_d - Q_s \quad (2)$$

The theoretical displacement  $D$  per revolution (where  $Q_d = ND$  and  $N$  = revolutions per unit time) can be found by integrating the differential rate of a net volume transfer over one shaft revolution with respect to the angular displacement of the drive shaft through any complete planar segment taken through the pump chamber between the inlet and outlet ports. Most pump rotors have constant radial dimensions in the axial direction in the body cavity and sweep a right circular cylinder of volume while rotating. This means

in single-rotor pumps or in multiple-rotor pumps where no sealing contact exists between rotors (all dynamic seals are formed between rotor elements and body surfaces), the volume transfer computation can be based on polar coordinates centered on each rotor axis and the contribution to the net volume transfer found for each rotor independently.

In general, the axial dimension of the rotor in the body cavity can be most simply expressed if the planar segment is taken through the rotor axis, or at least parallel to the rotor axis. Also, for most types of rotary pumps, the computation is simplified if the intersections of the plane with the body cavity occur in a CTIO region, usually midway between the inlet and outlet ports of the pump. This is particularly true for those rotary pumps that pump equally well in either direction of rotation and are generally symmetric. In many cases, the computation can be further simplified by separating the differential statement for volume transfer through the plane from the inlet to the outlet from that for volume transfer through the plane from the outlet to the inlet and expressing the results as a difference. Examples of this method of computation for some commonly used types of rotary pumps follow.

A section through a vane pump is shown in Figure 14. Let  $z$  be the axial distance toward the front endplate from the rotor end surface next to the rear endplate, and let  $Z$  be the total axial length of the rotor. Let  $r$  be the radial distance from the rotor axis. Let  $R_1$  be the minimum radial dimension of the rotor elements at the intersection of the plane with the minor cam radius of the pump chamber in the CTIO zone. Let  $R_2$  be the maximum radial dimension of the rotor elements at the intersection of the plane with the major cam radius of the pump chamber in the CTIO zone. Let  $\phi$  be the angular displacement of the drive shaft (assumed to be direct-coupled to the rotor with no gear increase or decrease). Then, the general equation for  $D$  is

$$D = \int_{\phi=0}^{\phi=2\pi} \int_{r=R_1}^{r=R_2} \int_{z=0}^{z=Z} krd\phi dr dz = k\pi Z(R_2^2 - R_1^2) \quad (3)$$

where  $k$  is a constant used to convert  $D$  to desired units ( $k = 1$  if  $z$  and  $r$  are in feet and  $D$  is in cubic feet per revolution). For vanes with non-zero thickness, the actual value of  $D$  will be slightly smaller than this.

The equation describing the transition of the major radius cam surface to the minor radius cam surface is not used or needed in Equation 3, because the planar segment is entirely in the CTIO zone of the pump. Also, the integration limits for  $r$  were chosen by noting that the net volume transfer for all  $r < R_1$  cancels and equals zero. The same result is obtained if the integral is expressed as the difference of the positive contribution of the integration limits 0 to  $R_1$ .

The same computations and formula apply to flexible vane pumps with the vanes on the rotor and to any vane-in rotor pump where the surface creating the pumping action is

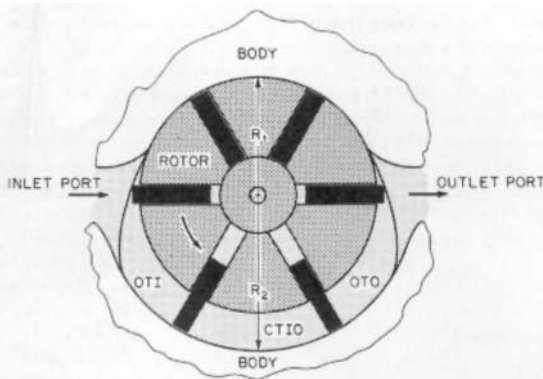


FIGURE 14 Displacement calculation dimensions for an internal vane pump

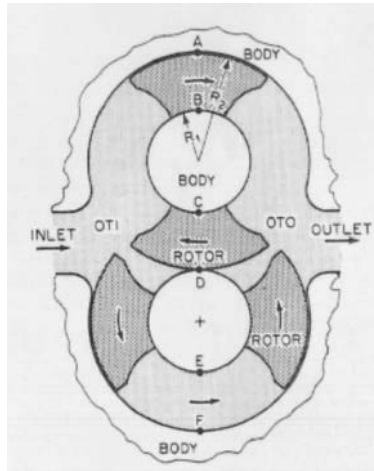


FIGURE 15 Displacement calculations for an external circumferential piston pump

formed on the interior surface of the body chamber. The equation can be used for most single-rotor positive displacement pumps with an appropriate selection of the numerical values for  $R_1$  and  $R_2$ . For example, in the vane-in-body pump,  $R_1$  is the minimum radius of the rotor cam and  $R_2$  is the maximum radius of the rotor cam.

An example extending this method of computing displacement to multiple-rotor pumps that have no rotor-to-rotor sealing contact is the computation on the external circumferential piston pump shown in Figure 15. A derivation can be made in the same manner used for the vane pump, and the individual equations for the net volume flow for each rotor can be computed and summed.

The pump in Figure 15 is symmetrical, and the net contribution of each rotor occurs only during a total of half of the drive shaft revolution. In the derivation shown in Equation 3, this would mean a change in the integration limits of  $\phi$  from  $2\pi$  to  $\pi$  for the contribution of each rotor. However, when the contributions from each of the two rotors are added, the result is the same as Equation 3.

Another method could also be used. Because of the pump symmetry, an inspection shows that two net volume components are continually transferred from the inlet to the outlet chamber by the motion of the rotors in zones  $A-B$  and  $E-F$ . One equal volume element is also continually transferred from the outlet to the inlet chamber of the cooperative action of the rotors in zone  $C-D$ . Consequently, the net volume being transferred from the outlet to inlet in zone  $C-D$  is continually canceled by one of the volumes continually being transferred from the inlet to outlet at either zone  $A-B$  or zone  $E-F$ . The entire computation then can be made only for zone  $A-B$  or zone  $E-F$  over the entire revolution. The resulting formula for displacement would be that given in Equation 3, with  $R_1$  being the minimum radial dimension of the piston element of the rotor and  $R_2$  being the maximum radial dimension of the piston element of the rotor.

The direct computation of displacement for multiple-rotor, positive displacement pumps with a moving seal is formed by contact between rotors is much more complex. In such pumps, the equation of motion of the locus of the contact point between rotors as a function of angular displacement of the drive shaft is needed for a rigorous solution of the displacement. The differential rate of volume transfer is not constant with angular displacement but decreases as the contact locus moves toward the inlet chamber and increases as the contact locus moves toward the outlet chamber. In this case, a graph of pump displacement versus angular displacement would not be a straight line (or constant function of angular displacement), as in the prior two examples. In effect, the motion of the contact locus superimposes a ripple on the steady-state component of the differential rate of volume transfer.



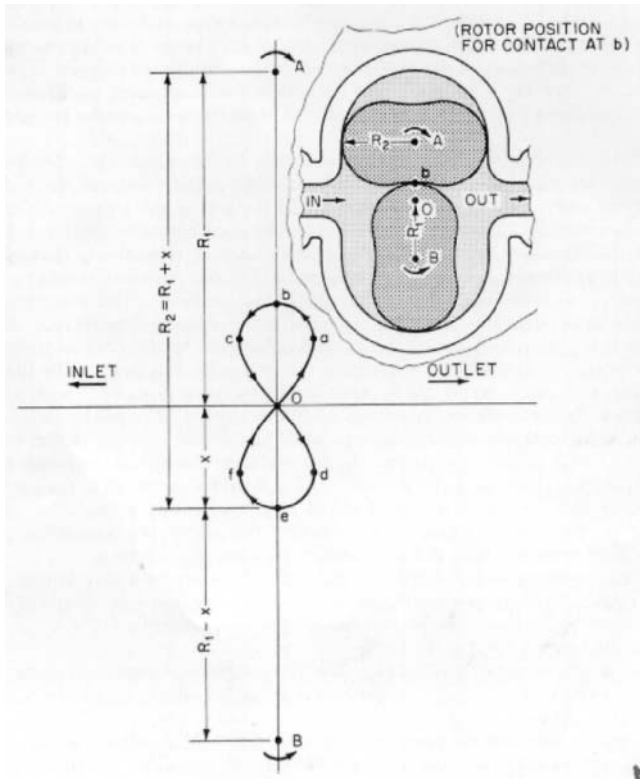


FIGURE 16 Rotor contact locus of lobe pump

Figure 16 shows the locus of the contact line between lobes in a two-lobe pump. The locus is shown on a plane taken perpendicular to the planar segment used for computing displacement, which is taken through the axis of both rotors with the center of rotation of the two rotors being points  $A$  and  $B$ . Point  $O$  is midway between the two rotor centers. The lower-case letters represent essential points in the differential rate of volume transfer.

Remembering that velocity of the movement of the locus point toward or away from the outlet port determines the amount of plus or minus deviation from the average differential transfer rate, the following observations can be made.

The maximum instantaneous differential volume transfer rate occurs as the locus passes through point  $O$  on its way from  $c$  to  $d$  or from  $f$  to  $a$ . The minimum instantaneous rate of differential transfer occurs when the locus passes through point  $b$  or point  $e$ . The average differential rate of transfer occurs at points  $a$ ,  $c$ ,  $d$ , and  $f$ . In the symmetric case shown, if  $R_1$  is the distance from  $O$  to  $A$  or  $B$ , if  $x$  is the distance from  $O$  to  $b$  or  $e$ , and if  $R_2$  is the maximum radial dimension of a lobe, then derivations similar to those given before will give the maximum and minimum differential rates of volume transfer:

$$\frac{dD}{d\phi_{\max}} = kZ(R_2^2 - R_1^2) \quad (4)$$

$$\frac{dD}{d\phi_{\min}} = (kZ(R_2^2 - R_1^2 - x^2) = kZ[2(R_2R_1 - R_1^2)])$$

since, for the lobe pump shown,  $R_2 = R_1 + x$ .



In most pumps of practical design, the peak-to-peak amplitude of the ripple is less than 10 percent of the steady-state component of displacement. Consequently, computing the peak displacement (where  $R_2$  is the maximum radial dimension of the rotor and  $R_1$  is half the distance between rotors of equal size) can approximate the displacement for multiple-rotor pumps with contacting rotors. The equation is given as

$$D_{av} = 2\pi kZ \left( \frac{R_2^2}{2} + R_2 R_1 - \frac{3}{2} R_1^2 \right) \quad (5)$$

$$D_{\min} = 4\pi kZ (R_2 R_1 - R_1^2)$$

$$D_{\max} = 2\pi kZ (R_2^2 - R_1^2)$$

If the rotors are of unequal size, the transfer rate must be computed for each rotor with  $R_1$  taken as the radius of the pitch circle of the rotor. This also applies to gear pumps where  $R_1$  is the radius of the pitch circle of the gears. Displacement computed by this simplified method will usually be within five percent of the true average displacement for lobe pumps and within one percent for gear pumps. For a closer approximation, Equation 5 can be used. It is precise only when the ripple waveform has a zero average component and when it is symmetric.

From a practical standpoint, pump displacement often cannot be computed precisely from the geometry of the pump and is instead established by testing. In either case, the manufacturer will usually state this because it is needed to determine the efficiency of the pump under various operating conditions.

**Speed Considerations** Centrifugal pumps typically run at synchronous motor speeds. The flow and head are fine-tuned by such things as trimming the impeller or underfiling the impeller vanes. Rotary pumps, on the other hand, operate with their internal dimensions fixed. Performance is usually fine-tuned externally by speed adjustments where the operating speed  $N$  is the number of revolutions of the driving or main rotor per unit time. When no gear reduction or increase exists between the drive shaft and the main rotor, the speed is measured or set at the drive shaft.

The most common unit of speed is rpm, and its direction is usually described as either clockwise or counterclockwise when viewed from the front or drive end of the pump looking at the pump shaft. The economy of manufacturing, special pressure-balancing arrangements, relief valve orientations, and other such considerations have led to some pump designs requiring that the pump operate in one direction only. However, most rotary pumps will operate equally well in either direction.

Usually, no minimum speed exists for a rotary pump, but certain vane pumps that depend on a centrifugal force to draw the vanes out of their slots do have minimum speed requirements. Another exception is with low-viscosity fluids at high pressures where the slow speed enables slip to equal the theoretical displacement, resulting in no net output flow. To avoid this situation and assure the pump is running at a suitable volumetric efficiency, the pump should always run within its permitted speed range. Figure 17 shows a typical speed versus viscosity curve for a rotary pump.

Since flow is directly proportional to speed, it can be tempting to increase the pump speed above its maximum speed to obtain more flow. However, besides all the aforementioned concerns, one other item must be considered. With any rotary pump, as the cavities rotate, they present a void for the incoming fluid to fill. This void is available for a fixed amount of time, and the fluid in the suction chamber must accelerate to fill this void in the available time. The higher the fluid viscosity, the more energy is required to accelerate the fluid to fill the void. If the fluid cannot fill the void in the time available, a partial void and cavitation will occur.

**Pressure** The absolute pressure of the fluid at any location in the pump, expressed in lb/in<sup>2</sup> (bar), is the total pressure there and the basis for all other pressure definitions associated with pump operation. Helping to simplify matters, the velocity pressure  $P_{vel}$  component of the fluid is usually small enough relative to the total pressure to be neglected.

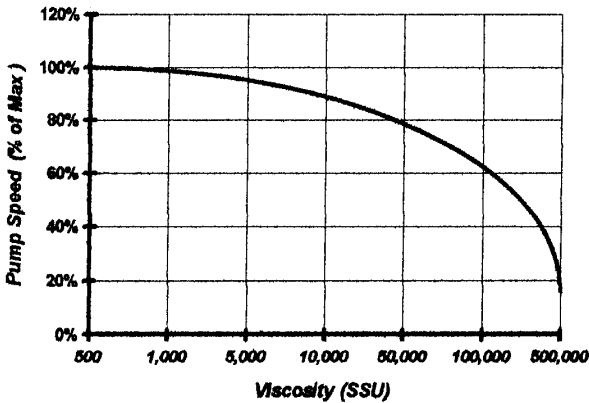


FIGURE 17 Typical speed reduction as a function of viscosity (In this range, centistokes = SSU/4.6)

In addition, where the fluid velocities (at the same pump locations used to determine the pressure differences) are sufficiently alike, they will cancel each other out. Should this not be so, velocity or dynamic pressure  $P_{vel}$  can be computed as

in USCS units 
$$P_{vel} = \frac{wV^2}{288g} \quad (6)$$

in SI units 
$$P_{vel} = \frac{wV^2}{20,387g}$$

where  $P_{vel}$  = dynamic pressure of the fluid being pumped

$w$  = fluid specific weight (mass), lb/ft<sup>3</sup> (kg/m<sup>3</sup>)

$V$  = fluid velocity, ft/s (m/s)

$g$  = acceleration due to gravity, ft/s<sup>2</sup> (m/s<sup>2</sup>)

or can alternately be expressed as

in USCS units 
$$P_{vel} = 0.000357 \left( \frac{w}{g} \right) \times \left( \frac{Q}{a} \right)^2 \quad (7)$$

in SI units 
$$P_{vel} = 13,600 \left( \frac{w}{g} \right) \times \left( \frac{Q}{a} \right)^2$$

where  $Q$  = flow, gpm (m<sup>3</sup>/min)

$a$  = cross-sectional area perpendicular to flow, in<sup>2</sup> (mm<sup>2</sup>)

Several pressure terms are of interest. The *outlet* or *discharge pressure*  $P_o$  is the total pressure at the outlet of the pump. In pumps with multiple outlets, this pressure is usually defined at the location in the outlet manifold where the pump is mated to the external piping system. Although composed of the sum of system and velocity pressures external to the pump, the outlet pressure is most commonly expressed as the gage pressure at the outlet port. The gage pressure (lb/in<sup>2</sup> gage or bar) is the difference between the absolute pressure and atmospheric pressure at the point of measurement.

The *inlet* or *suction pressure*  $P_{in}$  is the total pressure at the inlet to the pump or, for multiple-inlet pumps, at the manifold location where the pump connects to the external piping system. In common practice, the inlet pressure can be variously expressed as absolute pressure (lb/in<sup>2</sup> absolute or bar), as positive or negative gage pressure (lb/in<sup>2</sup> gage or bar), or as vacuum (inches or millimeters of mercury).

The total *differential pressure*  $P_d$  is the algebraic difference between the outlet pressure and the inlet pressure, with both expressed in the same units. This differential pressure is used in the determination of power input and in evaluating the slip characteristics of the pump:

$$P_d = P_{out} - P_{in} \quad (8)$$

The *net inlet pressure*  $P_{net\ in}$  of a rotary pump is the difference between the inlet pressure expressed in absolute units and the vapor pressure of the fluid expressed in absolute units:

$$P_{net\ in} = P_{in} - P_{vapor} \quad (9)$$

Expressed as head of the pumped liquid, this is the net positive suction head, *NPSH*. The required *NPSH* or *net inlet pressure required*  $P_{nifr}$  is the minimum net inlet pressure that can exist without the creation of enough vapor in the inlet to interfere with proper operation of the pump. The inlet pressure usually is not the true minimum pressure in the OTI volume. The flow of fluid in its passage through the OTI volume causes a fluid friction pressure loss, which causes the pressure to drop below the inlet pressure at some point in the OTI volume or inlet chamber. This loss increases with fluid velocity and hence with pump speed and fluid viscosity. It is a function of the pump geometry, which determines the fluid path lengths and local velocities where the fluid changes direction in flowing around curves or corners in the pump OTI volume boundary.

The required net inlet pressure is established by the manufacturer for particular speeds, pressures, and fluid characteristics. In practice, the pump user is warned that the net inlet pressure is near or at the required net inlet pressure by noisy and rough operation of the pump caused by the incomplete filling of the CTIO volume with an accompanying reduction in pump flow rate.

The two other pressure ratings used are the maximum allowable working pressure, which is the maximum gage pressure at the outlet port permitted for safe operation. It is usually determined by the stiffness and strength of the pump body and the type of seals used. The maximum differential pressure is the maximum allowable difference between the outlet pressure and the inlet pressure, measured in the same units, and is determined by the capability of the rotating assembly and its fluid seal contact zones to withstand the pressure difference between the OTO and OTI volumes.

**Power** Most of the pump *input shaft power*  $HP_{in}$  ( $kW_{in}$ ) is the power imparted to the fluid delivered by the pump at given operating conditions and is frequently called *liquid* or *hydraulic power*  $HP_{hyd}$  ( $kW_{hyd}$ ). A common unit used for expressing power ratings is horsepower (kilowatts) and can be computed by the equation:

$$\text{In USCS units} \quad HP_{hyd} = \frac{Q_d \times P_d}{1714} \quad (10)$$

$$\text{In SI units} \quad kW_{hyd} = \frac{Q_d \times P_d}{36}$$

where the constant 1,714 (36) gives the hydraulic power input in *hp* ( $kW$ ) when  $Q_d$  is in gpm ( $m^3/h$ ) and  $P_d$  is the differential pressure in  $lb/in^2$  (bar). This is the theoretical power or the required power independent of mechanical friction power losses, and fluid friction power.

The *mechanical friction power losses*  $HP_{losses}$  ( $kW_{losses}$ ) have two components. One is the mechanical friction power required by the elements outside the pumping chamber, such as the bearings and seals, and is usually independent of the fluid being pumped, the pump speed, and the differential pressure. The mechanical friction power inside the pumping chamber depends also on the pump speed and pump differential pressure, but it also depends on the viscosity and lubricity of the fluid.

The *fluid friction power losses*, or *viscous power losses*, are a function of the viscosity of the liquid being handled and on the shear rate in the fluid, which is a function of pump design and pump speed. When handling high-viscosity liquids, the viscous friction power

grows with viscosity, even if speed and pressure remain constant. This power loss depends on a number of design features of the pump and usually will grow proportionally to the viscosity to the  $n$ th power, where  $n$  usually ranges between 0.3 and 1.0 for most rotary pumps. Increasing any clearances in a pump reduces the shear stress in the liquid in those clearances at any given speed and consequently reduces the torque to overcome the viscous friction.

The *useful output power*  $HP_{out}$  is less than  $HP_{hyd}$  by an amount  $HP_{slip\ loss}$  due to leakage  $Q_{slip}$  through the clearances. Thus, *overall efficiency*  $E_{overall} = HP_{out} / HP_{in}$ , where (for SI units, substitute  $kW$  for  $HP$ )

$$HP_{in} = HP_{slip\ loss} + HP_{mech\ loss} + HP_{friction\ losses} + HP_{out} \quad (11)$$

**Efficiency** Rotary pumps are measured by their *volumetric*, *mechanical*, and (as just defined) *overall* efficiencies. This often requires certain trade-offs when selecting a pump for a given set of conditions since a rotary pump does not have a *single best efficiency point* (BEP) the way a centrifugal pump does.

Volumetric efficiency  $E_{vol}$  compares actual to theoretical output flows. It is an indication of both a pump's capability to handle a given differential pressure and viscosity and, in the case of older pumps, an indication of possible internal wear. The more flow a pump can deliver under these conditions, the higher its volumetric efficiency will be. The volumetric efficiency of a rotary pump is defined as

$$E_{vol} = \frac{Q_d - Q_s}{Q_d} \quad (12)$$

where  $Q_d$  = displacement or geometric flow delivered, in gpm ( $m^3/hr$ )

$Q_s$  = slip flow, in gpm ( $m^3/hr$ )

The positive displacement nature of rotary pumps makes them suitable for many metering applications. The pump would be a perfect metering device with zero errors if there were no slip. It would be considered a dependable meter if the slip were low or maintained constant over the entire range of operating conditions. A useful ratio in a comparison of different types of rotary pumps for a given metering application is the ratio of minimum flow rate in any of the operating conditions to the maximum flow rate in any of the operating conditions at a given speed. In variable-speed applications, the ratio of minimum volumetric efficiency to maximum volumetric efficiency is substituted. The metering effectiveness is highest as this ratio approaches unity. The difference between this ratio and  $1 \times 100$  is the percentage of change that can be expected either in the flow rate of the pump or in the total amount of fluid displaced for a given number of revolutions under extremes of operating conditions (such as pressures, temperatures, viscosities, and so on)

Volumetric efficiencies fall in the range of 65 to 98 percent for most rotary pumps. A changing volumetric efficiency over time usually indicates changing system conditions of service or pump wear.

Mechanical efficiency  $E_{mech}$  is the ratio of the pump input hydraulic power to input shaft power. It can also be looked at as the comparison of theoretical input power required for the actual power required. The less power a pump requires to produce a given amount of hydraulic work (output), the higher its mechanical efficiency. The total volume of fluid  $Q_d$  handled by the pump is larger than  $Q$  when slip is present. The amount of slip actually represents wasted power and affects pump efficiency. The difference between shaft power input and hydraulic power input consists of the power lost to mechanical friction and the power lost to fluid friction (a function of the viscosity of the fluid and pump shear stresses on the fluid). The mechanical efficiency of a rotary pump is found by the equation

$$E_{mech} = \left\{ \frac{HP_{hyd}}{HP_{in}} \right\} = \left\{ \frac{HP_{hyd}}{HP_{hyd} + HP_{losses}} \right\} \quad (13)$$

Overall efficiency  $E_{overall}$  is the most important efficiency because it alone determines the overall effectiveness of a pump for an application. That is, knowing only the volumetric or mechanical efficiencies can result in misleading conclusions. Only with a satisfactory

overall efficiency one can be reasonably assured of overall satisfactory performance. Overall efficiency is defined in terms of  $E_{mech}$  and  $E_{vol}$  as follows:

$$\text{in USCS units} \quad E_{\text{overall}} = \left\{ \frac{Q_d - Q_{\text{slip}}}{Q_d} \right\} \times \left\{ \frac{HP_{\text{hyd}}}{HP_{\text{hyd}} + HP_{\text{losses}}} \right\} \quad (14)$$

$$\begin{aligned} \text{in SI units} \quad &= \left\{ \frac{Q_c}{Q_d} \right\} \times \left\{ \frac{kW_{\text{hyd}}}{kW_{\text{in}}} \right\} \\ &= E_{\text{vol}} \times E_{\text{mech}} \end{aligned}$$

Another way of looking at overall efficiency is

$$E_{\text{overall}} = \left\{ \frac{Q_{\text{actual}}}{Q_{\text{theoretical}}} \right\} \times \left\{ \frac{HP_{\text{theoretical}}}{HP_{\text{actual}}} \right\} \quad (15)$$

**Pump Performance** Figures 18, 19, and 20 show the change in displacement capacity  $Q_d$ , flow rate or capacity  $Q_c$ , and slip  $Q_s$ , as the differential pressure across the pump  $P_d$ , the viscosity  $\nu$ , and the pump speed  $N$  are varied. Several assumptions are made in these graphs. It is assumed that inlet conditions are satisfactory and that there is no inlet effect on the pump capacity over the charted range. It is assumed that the fluid is Newtonian and the liquid is incompressible. In Figures 18 and 19, it is assumed that viscosity is constant and relatively low, and that the speed is within the normal range of the pump. In Figure 20, it is assumed that both pressure and speed are within the normal ratings of the pump.

The graph in Figure 18 is plotted with the flow rate, slip, and displacement flow rate on a linear scale as the ordinate (Y-axis) and pressure on a linear scale as the abscissa (X-axis). A further assumption is that the clearances and viscosity are such that the slip increases proportionately with pressure. The solid lines are the ideal characteristics when secondary effects are neglected. It may be noted that at zero pressure, slip  $Q_s$  is zero and  $Q_c$  equals  $Q_d$ . As the pressure increases,  $Q_s$  increases until it equals  $Q_d$  at pressure B. If the pressure imposed on the pump were to increase past this point,  $Q_s$  would exceed  $Q_d$  and the flow through the pump would be from outlet to inlet, causing a negative  $Q_c$ .

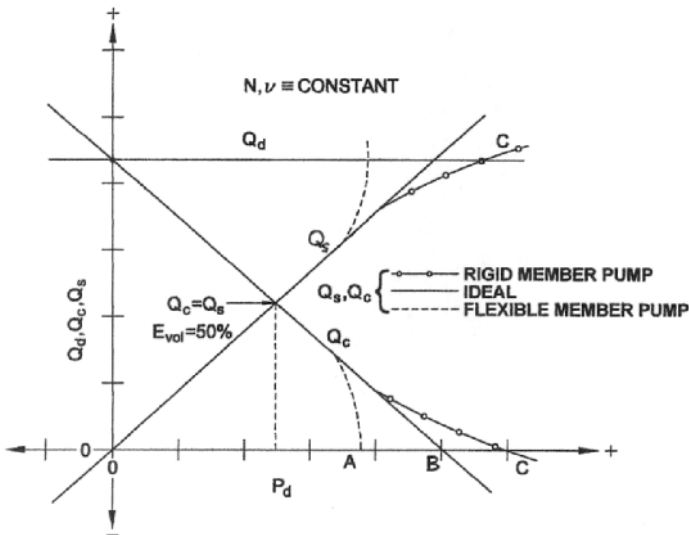


FIGURE 18 Variation of  $Q_d$ ,  $Q_c$ , and  $Q_s$  with  $P_d$ ,  $N$  and  $\nu$  constant

Although rotary pumps do not operate in this end of the pressure range, the condition of pressure  $B$  can be reached when a valve is closed, blocking the outlet of the pump. Pressure  $B$ , then, represents dead-ended pressure developed by a rotary pump when its outlet line is blocked. Should  $Q_d$  be numerically equal to 100 in whichever units are used, then the plot of  $Q_c$  is numerically equal at each point to the volumetric efficiency  $E_{vol}$  of the pump and  $Q_c$  becomes zero at pressure  $B$ .

Pressure  $B$  data is usually not available from pump manufacturers since these values are usually far beyond the normal safe pressure rating of the pump. However, they can be estimated by extrapolating the data given. Cautions should be observed, however. A flexible member can quickly reach a pressure at which flexible member deflection becomes excessive, and the pressure at which  $Q_c$  equals zero is very quickly reached. This is illustrated in Figure 18 by the dashed line breaking away from the solid  $Q$  line and intersecting the abscissa at pressure point  $A$ . This characteristic of flexible member pumps provides a self-limited maximum pressure should the pump be dead-ended. In rigid rotor pumps, as the pressure increases beyond the normal operating range, deflections of the shafts and rotors bring the rotors into heavy bearing contact with the body chamber walls, reducing the dimensions of the slip clearance path. The dashed line leaving the  $Q_c$  and  $Q_s$  curves and intersecting the abscissa and  $Q_d$  line at pressure point  $C$  illustrates this. Consequently, the zero flow pressure, which is ideally at point  $B$ , may be considerably different from this extrapolated value, and it should be measured if it is important to the application.

Under the same assumptions given for Figure 18, Figure 19 shows the relative independence of the slip with speed when differential pressure is constant. Here the chart of  $Q$  intersects the abscissa at the point where the speed is low enough for the displacement flow rate to be equal to the slip at the pressure of operation. The speed at which  $Q_d$  equals  $2 \times Q_s$  is the speed at which  $Q_s$  equals  $Q_c$  and the volumetric efficiency  $E_{vol}$  becomes 50 percent.

As the speed increases, the pumping action of the shear stress in the clearances tends to reduce the slip below the ideal line. However, for most rotary pumps, the detrimental effects of increasing the speed above the normal operating range is usually caused by inlet losses in the pump. This effect is cavitation and is illustrated by the dashed line, for which the net inlet pressure (N. I. P.) or  $NPSH$  is less than that required.

Figure 20 shows the effect of viscosity on the slip and flow rate in a rotary pump. The graphs are on a log-log scale. In this chart, it is assumed that the pressure, speed, and viscosity combine to keep the flow through clearances of the pump in the laminar or "viscous" flow region.

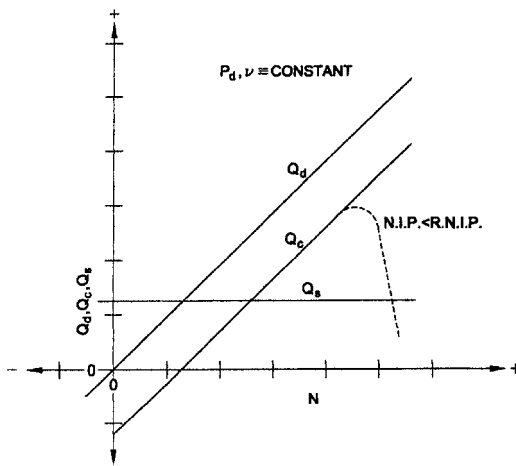


FIGURE 19 Variations of  $Q_d$ ,  $Q_c$ , and  $Q_s$  with  $N$ ,  $P_d$ , and  $\nu$  constant

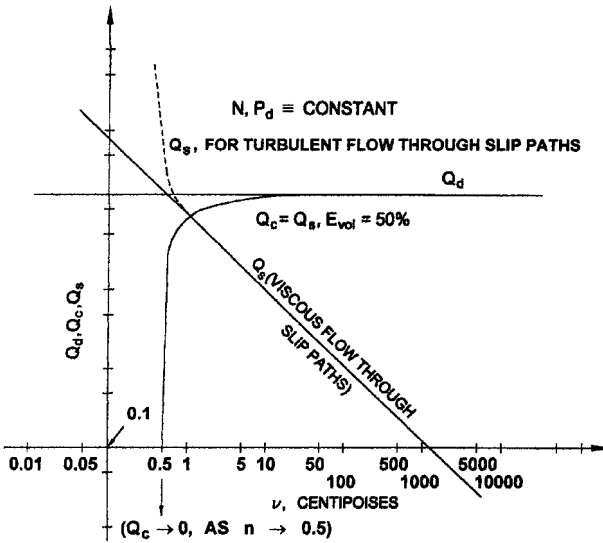


FIGURE 20 Variations of  $Q_d$ ,  $Q_c$ , and  $Q_s$  with  $\nu$ ,  $N$  and  $P_d$  constant

As viscosity increases, slip  $Q_s$  becomes very small and the flow rate of the pump  $Q_c$  approaches the displacement flow rate  $Q_d$ . As the viscosity decreases, the slip very rapidly approaches the displacement flow rate and the flow rate of the pump drops rapidly to zero or to a negative quantity. For any given pump with speed  $N$  and differential pressure  $P_d$ , there is a viscosity below which the slip flow, through clearances of the pump, will change to a turbulent flow. It is unlikely that this change will occur simultaneously through all slip paths. However, once it begins to occur, the slip will increase much more rapidly with further reductions in viscosity because of the turbulent flow relationship of the slip, pressure, and viscosity expressed in Equation 16:

$$Q_s = \frac{KP_d^{1/2}}{\nu^{1/x}} \quad (16)$$

where  $x$  usually is in the range of four to 10, and  $K$  is a constant.

Volumetric efficiency  $E_{vol}$  drops very rapidly with the viscosity if the viscosity is lower than that required for 50 percent volumetric efficiency (represented by the crossover point of the slip and capacity curves). This crossover point occurs for most rotary pumps operating at rated differential pressure  $P_d$  for viscosities between 0.1 and 10 centipoise. For the majority of commercially available models, this point usually falls in the viscosity range of 0.3 to 3.0 centipoise at the maximum rated differential pressure.

The effect of inlet pressure on the capacity can be seen clearly if all secondary effects are eliminated. This assumes the pump is operating within its normal pressure limits and speed range and that viscosity is high enough to reduce the slip to a negligible value. A graph of the capacity as a function of inlet pressure is shown in Figure 21 with these assumptions.

There is no change in capacity or flow rate as inlet pressure is lowered until the pressure reaches pressure  $A$  on the graph. If the inlet pressure were lowered further, the flow rate would drop as shown. The cause of this drop is complex in detail but simple in concept. The liquid flow from the inlet port through the inlet chamber of the pump causes a pressure drop, which causes a minimum pressure point somewhere in the inlet chamber. When the pressure in the liquid at this minimum pressure point approaches the vapor pressure of the liquid, vapor begins to form there. When the amount and time persistence of this vapor cause the vapor to be swept into the CTIO volume of the pump, the amount

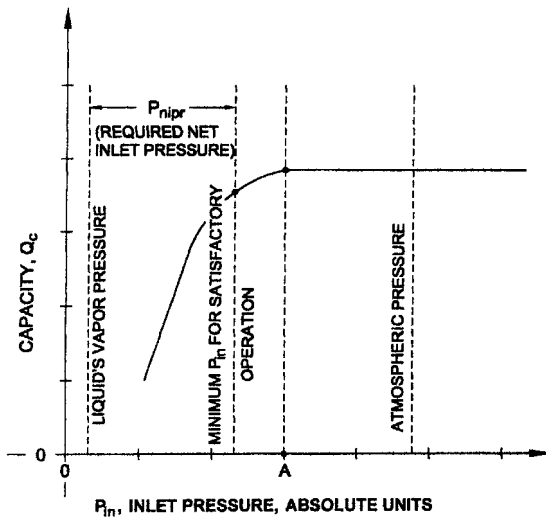


FIGURE 21 Variations of  $Q_c$  and  $P_{in}$  with other operating conditions constant

of liquid in this volume is reduced, leaving a deficiency of liquid volume. For example, if half the fluid volume swept from the inlet chamber is vapor, then only half the normal-capacity liquid volume is available at the outlet chamber, and the flow rate is reduced accordingly.

An increase in speed would mean an increase in flow rate, all other things being equal. This would increase the pressure drop between the inlet port and the inlet chamber and correspondingly increase the absolute inlet pressure (which is measured at the inlet port) at which the flow rate would begin to drop (pressure A). Correspondingly, if the speed and flow rate were constant and the viscosity increased, the pressure drop between the inlet port and the minimum pressure point in the inlet chamber would increase with viscosity. This also would cause pressure A to move to higher inlet absolute pressures. Operation with absolute inlet pressures below pressure A for any given speed and viscosity is usually unsatisfactory both because of the drop in capacity (and hence in volumetric efficiency) and because of the noisy and rough operation caused by the formation and collapse of the vapor.

For lower viscosity liquids where the collapse of the vapor bubbles may be quite rapid, cavitation may cause a significant amount of damage to the body or rotor surfaces. It is important to understand that cavitation damage may occur even though the absolute inlet pressure is above pressure A. Locations may be found in the inlet chamber, particularly where the flow direction changes rapidly, as around sharp corners, where vapor formation in the form of very fine bubbles, and hence cavitation, may occur. However, these vapor cavities may be swept into higher pressure regions of the inlet chamber and collapse near body or rotor surfaces to cause cavitation damage, although the capacity of the pump is not affected. For any given viscosity then, there is an upper limit to the speed at which the pump can be operated.

The inlet pressure may be allowed to drop slightly below pressure A without a significant deterioration in pump performance. However, there is a point at which the pressure becomes too low for satisfactory pump operation. This pressure determines the required net inlet pressure  $P_{nipr}$  or *NPSHR* for the particular pump and the particular set of operation conditions. For any given set of operating conditions, satisfying the required net inlet pressure or *NPSHR* is a main limitation on the pump operating speed.

The other main limit on the pump operating speed is the pump outlet pressure. In every application, some fluid frictional losses occur in the outlet system of the pump. Even if the pump outlet is opened to the atmosphere, a pressure drop exists between some maximum pressure point in the pump outlet chamber and the pump outlet itself. However, by far, the



most common situation is one in which a significant fluid friction pressure is developed in the system external to the outlet of the pump. This fluid pressure usually is a function of pump capacity and therefore of pump speed. If the inlet conditions are maintained to keep the inlet pressure above pressure  $A$  as the pump speed increases, a speed will be reached at which the pump outlet pressure equals the outlet pressure rating of the pump. Operating at speeds higher than this will cause the pump outlet pressure to exceed the rated pressure and this could result in damage to the pump.

These two limits on pump speed are illustrated in Figure 22. Three sets of operating conditions are shown. In operating condition 1, the outlet system friction resisting liquid flow (outlet system impedance) is relatively high and the outlet pressure developed by the flow is directly proportional to the pump flow rate (laminar flow). No static head exists in the system, and the outlet pressure is developed only when the pump causes liquid to flow through the outlet system. The liquid viscosity is assumed to be low enough to permit some slip in the pump. The net inlet pressure is assumed to be above pressure  $A$  over the range of operations shown.

Operating condition 2 is the same as operating condition 1, except that a static head (static outlet pressure) exists in the outlet system. This head is the pressure at which the chart of pump outlet pressure in condition 2 intercepts the zero speed line.

Operating condition 3 is one in which the impedance to the liquid flow in the outlet system is relatively low, but the liquid viscosity is relatively high. In this condition,  $Q_c$  shown

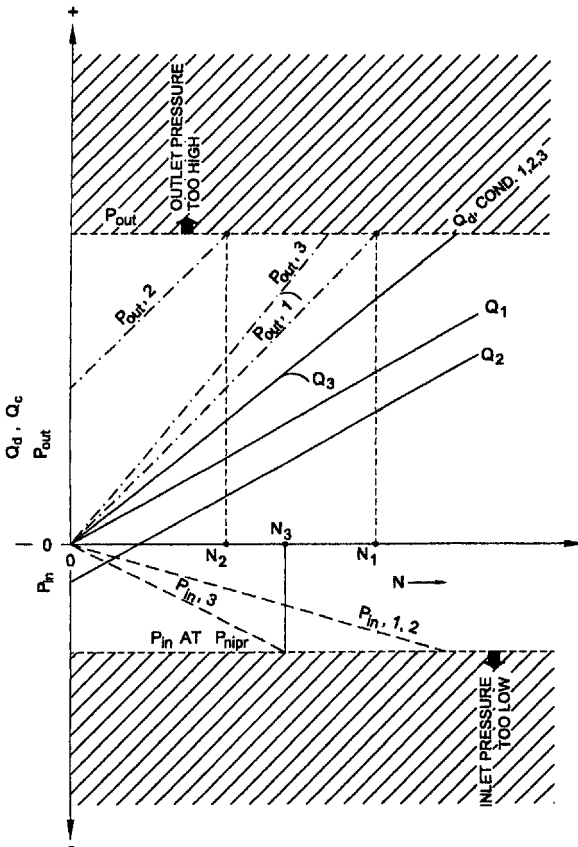


FIGURE 22  $P_{in}$  and  $P_{out}$  limitations on pump speed

as  $Q_3$ , is equal to the displacement flow rate  $Q_d$  as speed is increased until a speed is reached at which the available net inlet pressure of the pump drops to the required net inlet pressure of the pump. If the speed is increased beyond this point, the capacity of the pump would drop rapidly as an ever-increasing part of the pump fluid becomes vapor instead of liquid.

The upper limit of speed for satisfactory operation of the pump is shown as  $N_1$ ,  $N_2$ , and  $N_3$  for the three conditions described. The locations of  $N_1$ ,  $N_2$ , and  $N_3$  on the speed axis are independent of each other because they depend primarily on the operating conditions of the pump, the system in which it operates, and on the conditions of the pumped fluid. For example, a negative head in the outlet system could cause  $N_3$  to move to a higher value than  $N_2$ , and  $N_2$  to move to a higher value than  $N_1$ . Operation with a liquid with lower viscosity (but still sufficient to reduce the slip to zero) could cause  $N_3$  to be higher than  $N_1$ .

In most applications, one of the two limits described determines the maximum permitted speed of pump operation. However, if neither of these conditions limits the speed and the speed is continuously increased, a speed will be reached at which the peripheral velocity of the rotors will exceed the cavitation velocity of the liquid. A further increase in speed beyond this point would be limited by the cavitation occurring at the rotor outer radial surfaces.

### **SPECIFICATIONS, INDUSTRIES, AND APPLICATIONS**

---

In addition to the many application-oriented classifications for vane, gear, or lobe pumps, many technical classifications are also issued by various industrial, governmental, or even military organizations. It is also important for both the manufacturer and the user to know of any voluntary or regulatory specifications governing the construction and materials of the pumps destined for use in a specific industry and application.

Many industry-based specifications, such as the International Association of Milk, Food, and Environmental Sanitarians, the United States Public Health Service, and the Dairy Industry Committee, have jointly issued specifications called "The 3-A Sanitary Standards for Pumps for Milk and Milk Products." These standards govern the materials of construction of the pump, the surface finish and shape details of the contact surfaces, the finish and shape of external surfaces, the method of mounting, and restrictions on gaskets, seals, and other pump auxiliary features. Pumps constructed to meet 3-A Sanitary Standards are called *sanitary* pumps and carry a 3-A seal of approval mounted on the pump body. Similar specifications have been developed by the International Association of Milk, Food, and Environmental Sanitarians, the United States Public Health Service, the United States Department of Agriculture, the American Poultry Industries, and the Dairy and Food Industries Supply Association to cover design features used in the handling of cracked eggs.

Standards for pumps used in various processes in the petroleum industry are concerned with the materials and design features that are intended to prevent catastrophic failures when explosive, flammable, or toxic fluids are being handled. Others generated by governmental agencies and professional societies, such as the American Society of Mechanical Engineers and the American Petroleum Institute Standard 676, establish manufacturing procedures and design limitations on pumps for refineries, nuclear power stations, and so on. In these cases, the terms *sanitary*, *aseptic*, *explosion proof*, *API pump* or *N stamp* are not merely generic terms and cannot be casually applied. They must instead be carefully applied and used only when the manufacturer warrants that the pumps actually meet these specifications. In addition, as an unavoidable consequence, the cost of manufacturing pumps to meet any of these standards makes them more expensive than pumps built for general service applications.

Rotary pumps are used for both metering and transfer applications; so, most vane, gear, and lobe pumps are found in these services. Metering pumps tend to be smaller and operate with varying flow rates. Transfer pumps typically have a fixed speed, although variable speed units are becoming more common as the cost for this equipment falls.

In general, the three most basic applications for these pumps are as follows:

- 1. Liquid handling** In this class, well over 2,000 fluids are pumped and performance is judged on the pump's capability to handle the specific liquids, and the hydraulic power generated by the pump is a secondary consideration.

- 2. Hydraulic fluid power** In this class, the hydraulic power generated by the pump is used to actuate valves, pistons, cylinders, rotary actuators, and similar devices. Pumps in this class are usually vane, gear, piston, or screw types and are designed for pressures up to 9,000 lb/in<sup>2</sup> (620 bar) on selected hydraulic power fluids.
- 3. Commercial and retail** In this class are the pumps designed for a single specific use, application, or even fluid. Pumps in this miscellaneous class include everything from miniature pumps for home aquariums to well water pumps for agricultural use to fuel injection pumps for automobiles.

Among these three application areas, the most common is liquid handling tasks, and they make up the largest percentage of uses for rotary vane, gear, and lobe pumps.

**Markets and Applications** The markets and applications served by vane, gear, and lobe pumps are among the broadest of all rotary pumps. Although it would not be possible to list every application served by these pumps, a broad sampling of the more common ones is shown in Table 3.

## SUMMARY

In this section, we have discussed vane, gear, and lobe pumps in a general sense and covered many of the technical attributes that give them their unique characteristics. From an applications standpoint, the advantages these pumps have over other types can be summarized in Table 4.

**TABLE 3** Markets and applications

<p><b>Animal Renderings Industry</b> General transferring to burners of:</p> <ul style="list-style-type: none"> <li>• animal feed</li> <li>• beef by-products</li> <li>• bone meal</li> <li>• molten fats</li> <li>• poultry by-products</li> </ul>	<p><b>General Industry and OEM s</b> Various fluid handling requirements for:</p> <ul style="list-style-type: none"> <li>• burners and heater sets</li> <li>• centrifuge separator systems</li> <li>• cooking fat filtration units</li> <li>• filtering and metering units</li> <li>• fluid reclamation systems</li> <li>• hydraulic auto lifts and elevators</li> <li>• lube oil supply units for rotating equipment</li> <li>• machinery coolant and lubricant circulation</li> <li>• paint spray booths</li> <li>• roofing tar systems</li> <li>• textile dyeing and printing machinery</li> <li>• wood preservation machinery</li> </ul>	<p><b>Pulp and Paper Industry</b> Various general mill and coating applications for:</p> <ul style="list-style-type: none"> <li>• adhesives</li> <li>• black liquor</li> <li>• deinking solvents</li> <li>• fuel oil</li> <li>• printing ink</li> <li>• sulfate soap</li> <li>• tall oil</li> <li>• titanium dioxide slurry</li> <li>• turpentine</li> <li>• viscose</li> <li>• waste pond recycling</li> <li>• white liquor</li> </ul>
<p><b>Automobile Industry</b> Distribution and assembly line supply of:</p> <ul style="list-style-type: none"> <li>• grease</li> <li>• lubricating oil</li> <li>• motor fuel</li> <li>• paint, lacquers and thinners</li> <li>• test stand systems</li> </ul>	<p><b>Marine Industry</b> Unloading, tank stripping and engine room supply of:</p> <ul style="list-style-type: none"> <li>• asphalt</li> <li>• heating oil</li> <li>• heavy fuel oil</li> <li>• marine diesel oil</li> <li>• lubricating oil</li> <li>• molasses</li> </ul>	<p><b>Plastics and Petrochemical Industry</b> Process transfer of:</p> <ul style="list-style-type: none"> <li>• cellophane</li> <li>• epoxy hardener</li> <li>• film dope</li> <li>• insulation coatings</li> <li>• isocyanate</li> <li>• polyol</li> <li>• polyester</li> <li>• rayon</li> </ul>
<p><b>Chemical Industry</b> Any process or distribution system handling:</p> <ul style="list-style-type: none"> <li>• acids</li> <li>• adhesives</li> <li>• bleaches</li> <li>• caustics</li> <li>• cellulose acetate</li> <li>• glycerin</li> <li>• nitrates</li> </ul>	<p><b>Paint and Lacquer Industry</b> Various process handling applications for:</p> <ul style="list-style-type: none"> <li>• dyes and pigments</li> <li>• lacquer</li> <li>• latex</li> <li>• paint</li> <li>• titanium dioxide slurry</li> <li>• thinners and solvents</li> </ul>	<p><b>Public Utilities and Power Stations</b> General transfer and supply of:</p> <ul style="list-style-type: none"> <li>• central lubrication systems</li> <li>• fuel oil supply to burners</li> <li>• oil pressure for damper controls</li> <li>• transfer of gashouse tars, creosote, etc.</li> </ul>
<p><b>Cosmetics and Soap Industry</b> Non-emulsifying supply to packaging machinery of:</p> <ul style="list-style-type: none"> <li>• detergent</li> <li>• lanolin</li> <li>• liquefied soap</li> <li>• shampoo</li> </ul>	<p><b>Petroleum Industry</b> Blending, packaging, and unloading of:</p> <ul style="list-style-type: none"> <li>• asphalt</li> <li>• bitumen</li> <li>• creosote</li> <li>• grease</li> <li>• fuel oil</li> <li>• heavy fuel oil</li> <li>• lubricating oils</li> </ul>	<p><b>Steel Industry</b> Circulation and supply of:</p> <ul style="list-style-type: none"> <li>• coolants</li> <li>• quench oils</li> <li>• lube oil to rolling mills</li> <li>• hydraulic oil to hydraulic lifters</li> </ul>
<p><b>Food Products Industry</b> General process transferring of:</p> <ul style="list-style-type: none"> <li>• coconut oil</li> <li>• corn oil</li> <li>• fish oils</li> <li>• glucose</li> <li>• glycerin</li> <li>• lard</li> <li>• milk and milk by products</li> <li>• molasses</li> <li>• palm oil</li> <li>• sucrose solutions</li> <li>• vegetable shortening</li> </ul>		

**TABLE 4** The basic features and applications benefits of the main rotary pumps\*

Vane, Gear and Lobe Pumps	
Feature	Benefit
Flow largely independent of pressure	Predictable pump performance over varying system conditions
Wide hydraulic coverage- Flows to 10,000 GPM, differential pressures to 5,000 PSI	Few applications a rotary pump can't handle
Efficiently handles high viscosity fluids- over 100,000 SSU in some cases	Lower operating cost as efficiencies actually increase with viscosity
Smooth, pulse-free flow	Less system cost no need for vibration isolators or vibration dampeners
Self priming and will not vapor lock	Less system complexity - no need to prime or re-prime
Non-shearing pump action	Will not degrade shear sensitive polymers and petrochemicals

\*10,000 gpm = 2,300 m<sup>3</sup>/h; 5000 psi = 345 bar; 100,000 SSU =21,600 centistokes.

Many other types of rotary pumps were included in this discussion. The three types discussed here, and the numerous design variations of each type, constitute the bulk of rotary positive displacement pumps in use today.

C • H • A • P • T • E • R • 4

# JET PUMPS

---

# SECTION 4.1

---

# JET PUMP THEORY

---

RICHARD G. CUNNINGHAM

---

## INTRODUCTION

---

The jet pump transfers energy from a liquid or gas primary fluid to a secondary fluid. The latter may be a liquid, a gas, a two-phase gas-in-liquid mixture, or solid particles transported in a gas or a liquid. Examples of all these combinations have been reported in the technical literature. Reference 1, the major bibliography in this field, contains over 400 abstracts. Although the terms “ejector” and “eductor” are also applied, the term “jet pump” will be used here. The jet pump offers significant advantages over mechanical pumps: no moving parts for improved reliability, adaptability to installation in remote or hazardous environments, simplicity, and low cost. The primary drawback is efficiency: both frictional losses and unavoidable mixing losses are incurred. Nevertheless, careful design can produce pumps with efficiencies on the order of 30–40%. The jet pump in Figure 1 is typical of liquid-jet pumps and low Mach-number gas-jet/gas pumps. Compressible-flow pumps, for example, steam-jet ejectors, employ converging-diverging nozzles for full expansion of the jet.

---

## NOMENCLATURE

---

- $A$  = area, ft<sup>2</sup> (m<sup>2</sup>)
- $A_w$  = throat wall area, ft<sup>2</sup> (m<sup>2</sup>)
- $C$  = velocity of sound, ft/sec (m/s)
- CR = cavitation resistance
- $D$  = diameter, ft (m)

- $E$  = energy rate, ft lb/sec (joule/s)  
 $K$  = friction loss coefficient  
 $^{\circ}\text{K}$  = absolute temperature, Kelvin  
 LJL = liquid-jet liquid pump  
 LJG = liquid-jet gas compressor  
 LJGL = liquid-jet gas and liquid pump  
 $M$  = liquid/liquid flow ratio,  $Q_2/Q_1$   
 MN = Mach number  
 $N$  = pressure ratio, LJL jet pump  
 NPSH = net positive suction head  
 $P, P$  = pressure: static, total psia (kPa abs.)  
 $P_v$  = vapor pressure, psia (kPa abs.)  
 $Q$  = volumetric rate, ft<sup>3</sup>/sec (m<sup>3</sup>/s)  
 $\mathbf{R}$  = gas constant, ft lbs/slug  $^{\circ}\text{R}$  (joules/kg  $^{\circ}\text{K}$ )  
 $^{\circ}\text{R}$  = absolute temperature, Rankine  
 $S$  = density ratio,  $\rho_2/\rho_1$   
 $T$  = temperature  $^{\circ}\text{R}$  ( $^{\circ}\text{K}$ )  
 $V$  = velocity, ft/sec (m/sec)  
 $W$  = work rate, ft lbs/sec (joules/s)  
 $Z$  = jet dynamic pressure, psi (kPa)  
 $a$  = diffuser area ratio,  $A_i/A_d$   
 $b$  = jet pump area ratio,  $A_n/A_i$   
 $c = A_{2G0}/A_n = (A_i - A_n)/A_n = (1 - b)/b$   
 $m$  = mass flow rate, slugs/s (kg/s)  
 $s$  = seconds  
 psi = pounds per square inch  
 psia = pounds per square inch, absolute  
 $r_v$  = gas/liquid vol. flow rate ratio  $Q_G/Q_2$   
 $r_{v0}$  = gas/liquid vol. flow rate ratio at 0:  $Q_{G0}/Q_2$   
 $r_m$  = gas/liquid mass flow-rate ratio  
 sp = nozzle-to-throat spacing, ft(m)  
 sp/ $D_{th}$  = spacing, throat diameters  
 $\eta$  = efficiency  
 $\gamma$  = gas density ratio at  $s$ ,  $\rho_{G_s}/\rho_1$   
 $\gamma\phi_s = m_{G_s}/m_1$   
 $\rho$  = density, slugs/ft<sup>3</sup> (kg/m<sup>3</sup>)  
 $\tau$  = shear stress, psi (kPa)  
 $\phi$  = gas flow ratio  $Q_G/Q_1$   
 $\phi_s$  = gas flow ratio  $Q_{G_s}/Q_1$  at  $s$

### Subscripts

- 1 = liquid primary flow  
 2 = liquid secondary flow

- $G$  = gas secondary flow  
 $2G$  = bubbly secondary flow  
 $2G_0$  = bubbly sec. flow at 0  
 mep = maximum efficiency point  
 op = operating point  
 $L$  = limit for cavitating flow  
 $3$  = combined fluids 1, 2, and  $G$   
 $i, s, n$  = locations (see Fig. 1)  
 $0, t, d$  = locations (see Fig. 1)  
 $c_0$  = flow-ratio cut off  
 $f$  = friction loss  
 $n$  = nozzle  
 $en$  = throat entry  
 $th$  = mixing throat  
 $di$  = diffuser  
 $td$  = throat and diffuser

### Subscript Examples

- $Q_2$  = secondary liquid vol. flow rate  
 $Q_{G_0}$  = secondary gas flow rate, at 0  
 $Q_{2G_0}$  = flow rate of bubbly mixture of gas in the secondary liquid, at 0

NOTE: The convention for pressure and stress in this section is to use psi (and psia) for pounds per square inch (and pounds per square inch absolute) instead of the conventional lb/in<sup>2</sup> used throughout the rest of the handbook.

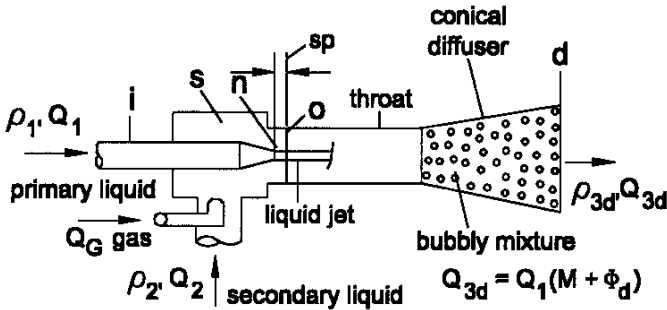


FIGURE 1 Liquid-jet gas and liquid pump and nomenclature

### LIQUID-JET PUMP THEORY FOR THREE SECONDARY-FLOW TYPES

The liquid-jet pump model is based on conservation equations for energy, momentum, and mass. Real-fluid losses are accounted for by friction-loss coefficients ( $K$ ). The primary or motive fluid is a liquid of density  $\rho_1$ . In the following derivation, the secondary/pumped fluid



can be a second liquid of density  $\rho_1$  or  $\rho_2$ , or a gas-in-liquid bubbly mixture, or a gas. These three jet pump flow regimes are referred to as liquid-jet liquid (LJL), liquid-jet gas liquid (LJGL), and liquid-jet gas (LJG). Equations (1), (3), (5), and (7) below apply to all three.

Assumptions:

- a. The primary and secondary streams enter the mixing throat with uniform velocity distributions, and the mixed flows leave the throat and diffuser with a uniform velocity profile.
- b. The gas phase—if present—undergoes isothermal compression in the throat and diffuser.
- c. All two-phase flows at the throat entry and exit consist of homogeneous bubble mixtures of a gas in a continuous liquid.
- d. Heat transfer from the gas to the liquid is negligible—the liquid temperature remains constant.
- e. Change in solubility of the gas in the liquid from pressure  $P_s$  to  $P_d$  is negligible.
- f. Vapor evolution from and condensation to the liquid are negligibly small.

NOZZLE EQUATION With reference to Figure 1

$$P_i + \rho_1 \frac{V_i^2}{2} = P_o + \rho_1 \frac{V_n^2}{2} + K_n \rho_1 \frac{V_n^2}{2} \quad (1)$$

For

$$P_i = \bar{P}_i$$

the nozzle equation is

$$P_i - P_o = Z(1 + K_n)$$

THROAT-ENTRY EQUATION The two-phase secondary flow is described by

$$\frac{dP}{\rho} = VdV + d\left(K_{en} \frac{V^2}{2}\right) = 0 \quad (2)$$

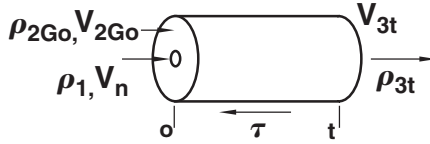
Density of the secondary fluid as a function of static pressure and flow ratios  $M$  and  $\phi$  is

$$\rho_{2G} = \frac{m_2 + m_G}{Q_2 + Q_G} = \frac{m_1 \left[ \frac{m_2}{m_1} + \frac{m_G}{m_1} \right]}{Q_1(M + \phi)} = \rho_1 \left[ \frac{SM + \gamma\phi_s}{m + \phi} \right]$$

Integration of Eq. (2) using this density relation and continuity results in the throat-entry equation:

$$M(P_s - P_o) + P_s \phi_s \ln \frac{P_s}{P_o} = Z \frac{SM + \gamma\phi_s}{c^2} (1 + K_{en})(M + \phi_o)^2 \quad (3)$$

MIXING THROAT MOMENTUM EQUATION Equating control volume forces and fluid momentum changes:



$$(P_0 - P_t)A_{th} - \tau A_w = (m_1 + m_2 + m_G) V_{3t} m_1 V_n - (m_2 + m_G) V_{2Go} \quad (4)$$

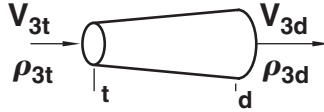
where

$$\frac{\tau A_w}{A_{th}} = \frac{K_{th} \rho_{3t} V_{3t}^2}{2}$$

Substituting the density and continuity relations in Eq. (4) and dividing  $A_{th}$  produces a quadratic equation in  $P_t$ . The throat momentum equation becomes

$$\begin{aligned} P_t^2 - Z \left[ 2b - b^2(2 + K_{th})(1 + SM + \gamma\phi_s)(1 + M) \right. \\ \left. + 2(SM + \gamma\phi_s)(M + \phi_0) \frac{b^2}{(1 - b)} + \frac{P_0}{Z} \right] P_t \\ + Z[b^2(2 + K_{th})(1 + SM + \gamma\phi_s)P_s\phi_s] = 0 \end{aligned} \quad (5)$$

**DIFFUSER EQUATION** The mixed primary and secondary fluids flow from  $t$  to  $d$ :



The  $t$ - $d$  flow is described by Eq. (6):

$$\int_t^d \frac{dP}{\rho} + \int_t^d V dV + \int_t^d \frac{\Delta P_f}{\rho_{3t}} = 0 \quad (6)$$

Integrating Eq. (6) and substituting the density and continuity relations, the diffuser equation becomes

$$\begin{aligned} (P_d - P_t) + \frac{P_s\phi_s}{1 + M} \ln \frac{P_d}{P_t} = Zb^2 \left[ \frac{1 + SM + \gamma\phi_s}{1 + M} \right] \\ \times [(1 + M + \phi_t)^2 - \alpha^2(1 + M + \phi_d)^2 - K_{di}(1 + M + \phi_t)(1 + M)] \end{aligned} \quad (7)$$

**LIQUID-JET PUMP EQUATIONS** The liquid jet pump is described in terms of the four flow processes by Equations (1), (3), (5), and (7). The term  $\gamma\phi_s = \rho_{Gs} Q_{Gs}/\rho_1 Q_1$ . For isothermal flow,  $\gamma\phi_s = 144P_s\phi_s/\mathbf{R}T_s\rho_1$ . For air, with  $\mathbf{R} = 1716$  ft lb/slug  $^\circ\mathbf{R}$ , and water,  $\rho_1 = 1.94$  slugs/ft<sup>3</sup> and  $\gamma\phi_s = .0432P_s\phi_s/T_s$ . In SI,  $\mathbf{R} = 286.92$  mN/kg  $^\circ\mathbf{K}$ ,  $\rho_1 = 1000$  kg/m<sup>3</sup>, and  $\gamma\phi_s = .00348P_s\phi_s/T_s$ , with  $P_s$  in kN/m<sup>2</sup>, and  $T_s$  in  $^\circ\mathbf{K}$ . The  $\mathbf{R}$  and/or  $\rho_1$  values must of course be replaced for fluids other than water and air.

In the LJGL pump, the secondary flow is a bubbly mixture of a gas in a liquid. Compressible flow phenomena must be considered because the velocity of sound is quite low in bubbly fluids. For example, the velocity of sound in a 50/50 uniform mixture of air in water is about 70 ft/s (21.3 m/s), far below sonic velocities in air (1100 ft/s or 335 m/s) or water (5000 ft/s or 1524 m/s).

The Mach number of a bubbly secondary flow at the throat entrance is (see Reference 5):

$$\text{MN}_{2G0} = \frac{V_{2G0}}{C_{2G0}} = \frac{\phi_0}{c} \sqrt{\frac{2Z}{P_s \phi_s} (SM + \gamma \phi_s)} \quad (8)$$

When this Mach number is 1.0, the LJGL pump has reached limiting flow; that is, a reduction in back pressure  $P_d$  no longer causes an increase in the bubbly secondary-flow rate.

**Pump Efficiencies** The LJGL pump produces two useful work results:

- Static-pressure increase of the liquid component of the secondary flow stream.
- If a gas is entrained in this liquid stream, isothermal compression of the gas component.

With  $W$  as the work rate, ft-lb/s, (power)  $W_L = Q_2 (P_d - P_s)$  is the work rate on the liquid component, and  $W_G = \rho_{G0} Q_{G0} \mathbf{RT} \ln(P_d - P_s)$  is the work rate on the gas component. The energy rate input is  $E_{in} = Q_1 (P_i - P_s)$ . The LJGL pump mechanical efficiency is the total work rate divided by the energy rate in

$$\eta = \frac{M(P_d - P_s) + P_s \phi_s \ln \frac{P_d}{P_s}}{P_i - P_d} = \eta_L + \eta_G \quad (9)$$

**The Jet Loss** Jet pumps in practical applications have nozzle-to-throat spacings  $sp/Dth$  of one or more mixing-throat diameters. The power jet traverses from a static pressure at or near  $P_s$  down to  $P_o$ , with no useful work recognized in the one-dimensional theory. Thus a “jet loss” occurs, which is in addition to the frictional and mixing losses (see Reference 9).

In the LJL and LJGL (but not the LJG) pumps, throat-inlet pressure drops—and hence jet losses—are significant (Ref. 6).

**Pump Efficiency, Incorporating Jet Loss** In Eq. (9),  $(P_i - P_d)$  is expanded:  $(P_i - P_d) = (P_i - P_s) - (P_d - P_s)$ , and  $(P_i - P_s) = (P_i - P_o) - (P_s - P_o) = Z(1 + K_n) - j(P_s - P_o)$ , where  $j = 1$  for a fully inserted nozzle, *no jet loss*; and  $j = 0$  for the usual case of retracted nozzle, which produces *full jet loss*. Eq. 9 now becomes

$$\eta = \frac{M(P_d - P_s) + P_s \phi_s \ln \frac{P_d}{P_s}}{Z(1 + K_n) - j(P_s - P_o) - (P_d - P_s)} = \eta_L + \eta_G \quad (10)$$

Eq. (10) is recommended for predicting liquid-jet pump efficiencies as follows: Use  $j = 0$  for pumps with normally-retracted nozzles (full jet loss); use  $j = 1$  for no-jet-loss pumps (thin-walled nozzle tip fully inserted so  $sp = 0$ ). The pressure in Eq. (10) should be calculated from the one-dimensional theory using Eqs (1), (3), (5), and (7). (See below for the LJL jet pump.)

**Computer Programs for LJGL and LJG Models** Solutions for the compressible flow cases are generated using computer spreadsheet or Fortran programs. Values for  $Z, b, P_s, T_s, \mathbf{R}, \rho_1, S$  and the four  $K$  coefficients are fixed/assumed for each pump and operating conditions. Eqs. (3), (5), and (7) are then solved for each step increase in flow-ratio  $M$ , with  $\phi_s$  held constant. Alternatively,  $M$  may be held constant and the equations solved for step increase in  $\phi_s$ . Eqs. (3), (5), and (7) are interdependent: solution of Eq. (5) requires  $P_o$  values from Eq. (3) and solution of Eq. (7) requires  $P_i$  values from Eq. (5). The program outputs at each flow-ratio step are static pressure  $P_o, P_i, P_d$ , and the three pump efficiencies defined by Eq. 10.

**LJGL FLOW CUT-OFF** Compressible-flow choking of the secondary stream at the throat entrance will occur at  $\text{MN}_0 = 1$ . The flow ratio at which this will occur can be predicted from critical-flow theory. For further details, see Reference 5.

Performance of the gas compressor (LJG) can be calculated from Eqs. (1), (3), (5), and (7) by setting  $M = 0$ . Although simplified, the equations are still coupled as in the LJGL case. The one-dimensional theory predicts actual performance quite well (see References 6 and 7) provided the mixing is completed within the length of the mixing throat. Theory-experiment agreement fails and the gas compressor efficiency declines—mixing is allowed to extend into the diffuser.

### THE LIQUID-JET LIQUID (LJL) PUMP

Equations for the LJL pump are much simpler than the corresponding LJGL and LJG equations because of the elimination of all  $\phi$  terms. In this case, Eqs. (1), (3), (5), and (7) reduce to the following set:

$$\text{Nozzle} \quad P_i - P_o = Z(1 + K_n) \quad (1)$$

$$\text{Throat Entry} \quad P_s - P_o = ZS(1 + K_{en})M^2/c^2 \quad (11)$$

$$\text{Throat} \quad P_t - P_o = Z[2b + 2SM^2b^2/(1 - b) - b^2(2 + K_{th})(1 + SM)(1 + M)] \quad (12)$$

$$\text{Diffuser} \quad P_d - P_t = Z_b^2(1 + SM)(1 + M)(1 - K_{di} - a^2) \quad (13)$$

Pump efficiency  $\eta$  is defined as the ratio of useful work rate on the secondary fluid  $Q_2$  to the energy extracted from the primary liquid:

$$\eta = Q_2(P_d - P_s)/Q_1(P_i - P_d) = MN \quad (14)$$

Two other definitions of efficiency are found in the literature, as follows:

$$\eta' = Q_2(P_d - P_s)/Q_1(P_i - P_s) = \eta/N + 1$$

$$\eta'' = (M + 1)(P_d - P_s)/(P_i - P_s)$$

These two other definitions assume that the primary/power stream pressure falls to  $P_s$ , not  $P_d$ , as shown in Figure 2. Efficiency conversions are possible only if all three pressures and two flow rates involved are given. Comparisons of efficiencies reported in the literature should be made with caution.

Combining Eqs. 1, 11–14, the theoretical pressure characteristic  $N$  for the LJL pump is

$$N = \frac{2b + \frac{2SM^2b^2}{1 - b} - b^2(1 + K_{td} + a^2)(1 + M)(1 + SM) - \left(\frac{SM^2}{c^2}\right)(1 + K_{en})}{1 + K_n - 2b - \frac{2SM^2b^2}{1 - b} + b^2(1 + K_{td} + a^2)(1 + M)(1 + SM) + (1 - j)\left(\frac{SM^2}{c^2}\right)(1 + K_{en})} \quad (15)$$

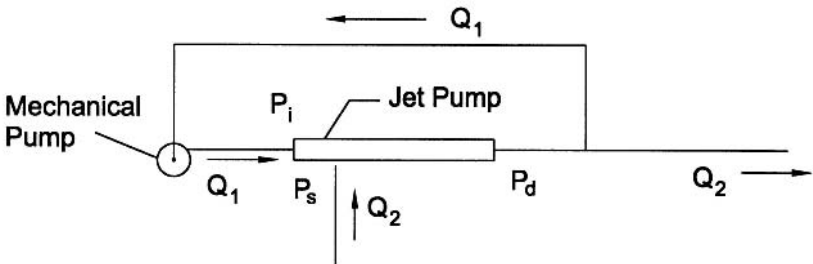


FIGURE 2 LjL jet pump and installation

where  $K_{td} = K_{th} + K_{di}$ . The term  $j = 0$  for the normal (jet loss) case, and  $J = 1$  for no jet loss. Jet pumps normally are designed with a finite nozzle-throat spacing, typically  $sp/D_{th} = 1$ ; jet loss is experienced, and thus  $j = 0$  for this (usual) case. Eq. (15) becomes

$$N = \frac{2b + \frac{2SM^2b^2}{1-b} - b^2(1 + K_{td} + a^2)(1 + M)(1 + SM) - \left(\frac{SM^2}{c^2}\right)(1 + K_{en})}{1 + K_n - \text{numerator}} \quad (16)$$

In terms of pressure,

$$N = (P_d - P_s)/(P_i - P_d)$$

Two simplifications of Eq. (16) are often appropriate: 1) The area ratio term  $a^2 = 0$  for the usual  $5^\circ$ - $8^\circ$  included-angle diffuser ( $a = A_i/A_d$  is small). 2) The density ratio  $S = 1$  for similar primary and secondary liquids, for example, a water primary jet pumping water as the secondary fluid. With these simplifications, Eq. (16) for the normal (jet loss) case becomes

$$N = \frac{2b + \frac{2SM^2b^2}{1-b} - b^2(1 + K_{td})(1 + M)^2 - \left(\frac{M^2}{c^2}\right)(1 + K_{en})}{1 + K_n - \text{numerator}} \quad (17)$$

And pump efficiency is

$$\eta = \eta_L = MN \quad (18)$$

For the L<sub>J</sub>L jet pump, note also that

$$(P_d - P_s)/(P_i - P_s) = N/(N + 1) \quad (19)$$

**Computer Programs for L<sub>J</sub>L Models** It is convenient to use Eqs. (17) and (18) in spreadsheet form to generate tables of “ $N(b, M, K_n, K_{td}, K_{en})$ ,” that is, the L<sub>J</sub>L jet pump pressure characteristic  $N$  as a function of the bracketed variables. Typically the  $K$ s and the area ratio  $b$  are held constant and a table is generated using step increases in  $M$  to show resultant  $N$  values. Table 1 shows  $N(M)$  for  $b = .25$ ; and  $K_n = .05$ ,  $K_{td} = .2$ , and  $K_{en} = 0$ . The performance of this pump is shown in Figure 3 as  $N(M)$  and  $\eta(M)$ .

**TABLE 1** Performance versus  $M$ , for  $b = .25$ ,  $K_n = .05$ ,  $K_{td} = .2$ ,  $K_{en} = 0$

$M$	$(P_d - P_s)/Z$	$(P_i - P_d)/Z$	$N$	$\eta\%$
0.000	0.4250	0.6250	0.6800	0.00
0.200	0.3942	0.6558	0.6012	12.02
0.400	0.3619	0.6881	0.5259	21.04
0.600	0.3280	0.7220	0.4543	27.26
0.800	0.2926	0.7574	0.3862	30.90
1.000	0.2556	0.7944	0.3217	32.17
1.200	0.2170	0.8330	0.2605	31.26
1.400	0.1769	0.8731	0.2026	28.36
1.600	0.1352	0.9148	0.1478	23.65
1.800	0.0920	0.9580	0.0960	17.29
2.000	0.0472	1.0028	0.0471	9.42
2.200	0.0009	1.0491	0.0008	0.19
2.204	0.0000	1.0500	0.0000	0.00
0.676	0.3147	0.7353	0.4280	28.93
1.014	0.2529	0.7971	0.3173	32.17

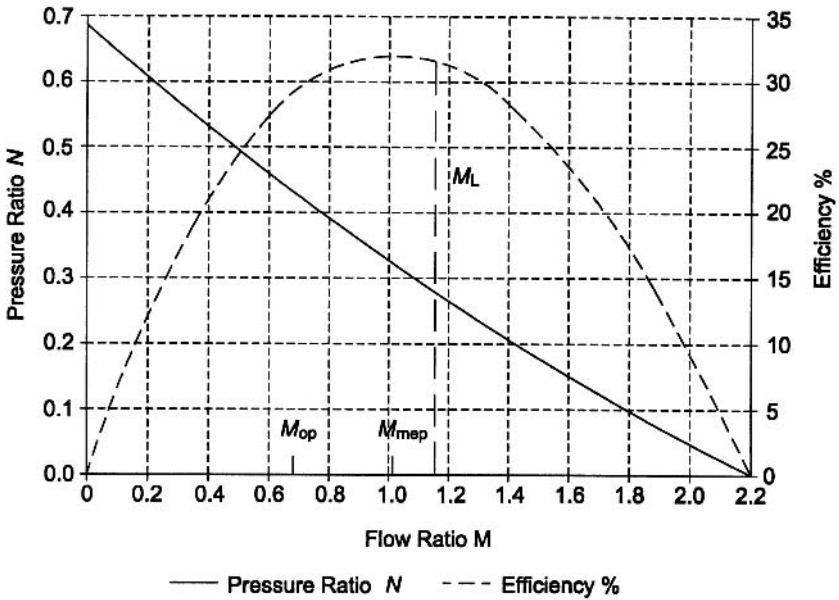


FIGURE 3  $K_n = .05, K_{td} = .20, K_{en} = 0$

It has been shown (see References 2, 3, 4) that one-dimensional analyses successfully predict actual LjL pump performance. But theory-experiment agreement obtains only if the test-pump flow conforms with the model assumptions. Two conditions that will cause departure of measured  $N$  and  $\eta$  data from the theoretical curves are

- Cavitation, which occurs in the mixing throat
- Extension of the throat mixing process out into the diffuser

**Operating Flow Ratio  $M_{op}$**  In Figure 3, the flow ratio  $M_{op}$  is indicated on the left slope of the “parabolic” efficiency curve, which peaks at  $M = M_{mep}$ . The recommended location of the design operating point is to set  $M_{op} = \frac{2}{3} M_{mep}$ . Higher operating  $M$  ratios would provide slightly higher efficiencies, but at a greater risk of cavitation. (Cavitation as part of the design process is included in the following examples given.) Finding  $M_{mep}$  can be readily accomplished from Table 1 type data using spreadsheet successive approximations. Alternatively, Eqs. (17)–(18) can be differentiated and set equal to zero to find the peak efficiency  $M_{mep}$  value.

**Cavitation** LjL pumps may encounter cavitation, which occurs in the mixing throat. With reference to Figure 3, the LjL pump normally responds to a reduction in back pressure  $P_d$  ( $Q_1$  and  $P_s$  constant) by producing a larger  $Q_2$  secondary flow, and hence a larger  $M$ . Measured pressure ratios ( $N$ ) and efficiencies ( $\eta$ ) track along these theory-based characteristic curves as shown in Figure 3. But after the throat-inlet pressure ( $P_c$ ) is reduced to the vapor pressure ( $P_v$ ) of the secondary liquid, any further drop in the back pressure has no effect on the flow ratio, which stabilizes at  $M = M_L$ , the *cavitation-limited flow ratio*. Note the vertical dashed line in Figure 3: measured  $N$  and  $\eta$  values fall on this vertical line, under  $M_L$  operating conditions. In this manner, cavitating-pump performance departs radically from predicted/normal behavior.

Published studies (see References 1 and 8) have shown that NPSH-type correlations adequately explain and predict cavitation-limited flow phenomena. **Comparing the predicted  $M_L$  with the intended  $M_{op}$  is an essential step in designing a jet pump**

**installation.** If  $M_{op} < M_L$ , the L<sub>J</sub>L pump can be expected to perform “on design;” that is, to follow the Eq. (17)  $N(M)$  relation, with no cavitation.  $M_L$  can be predicted from the operating conditions as follows (see Reference 8):

$$M_L = c \sqrt{\frac{P_s - P_v}{\sigma Z}} \quad (20)$$

where  $\sigma$  is a cavitation coefficient.

Experiments, primarily with water and lubricating oils, have shown a  $\sigma$  range of 0.8–1.4 (see Reference 1). One investigator (see Reference 10) found that improving the nozzle exterior profile and related throat-inlet internal profile reduced the measured  $\sigma$  from 1.4 to 1.0, indicating a significant improvement in cavitation resistance. For design use, a conservative value of  $\sigma = 1.35$  is recommended (see Reference 8).

**Area Ratio  $b$**  The nozzle-to-throat area ratio  $b$  is the only geometric parameter in these liquid-jet pump models, and including the L<sub>J</sub>L case, Eq. (17). Area ratio  $b$  is all-important, affecting pump efficiency, flow capacity, cavitation, and pressure characteristic  $N(M)$ . Comparisons of  $b$ -value series of pumps (see References 1–4) show that peak efficiency is highest for  $b = .2$  to  $.3$ . This optimum occurs because efficiency of the jet pump reflects the two unavoidable losses: friction and the mixing loss. The latter (a maximum at zero  $M$ ) decreases with rising  $M$ , whereas frictional losses increase with  $M$ . The sum of these losses is a minimum for pumps in the  $b = .2 - .3$  range, each operating at or near the respective  $M_{mep}$  (see Reference 9). As indicated in the numerical Examples 1 and 2 further on, it is recommended that jet pump designs start—in the absence of other restraints—with  $b = .25$ . This initial area ratio can then later be adjusted, for example, to handle a cavitation problem. In specific cases the jet pump placement, or a desired flow ratio, may determine  $N$  or  $M$ , and hence  $b$ . Example 3 illustrates the situation.

**Friction-Loss Coefficients** Solutions of Eqs. (11)–(18) require use of appropriate  $K$  loss coefficients. The following sources are suggested:

1. Adopt published results from jet pump studies that have included measurements of  $K$  values (see References 3, 10, 11).
2. Use published loss coefficients for the (four) components of the L<sub>J</sub>L pump; that is, converging nozzle, tube entry, short tube, and diffuser.
3. Measure  $K$ s directly by running flow test of jet pumps or component parts. Full evaluation of the four  $K$ s requires measurement of two flow rates and five static pressures,  $P_i$ ,  $P_s$ ,  $P_o$ ,  $P_t$ , and  $P_d$ . Most studies, however, have omitted  $P_o$  and  $P_t$  pressure taps, and measured only three of these pressures:  $P_i$ ,  $P_s$ , and  $P_d$ . This omission limits  $K$  evaluations based on pump tests to  $K_n$  and  $K_{td}$ . Fortunately, the theory works quite well under this limitation, largely because the throat and diffuser  $K$ s are additive ( $K_{td} = K_{th} + K_{di}$ ) in the  $N(M)$  equations.

In regard to Item 1 above, Table 2 shows the range and recommended values for the  $K$ s which appear in the theoretical model equations.

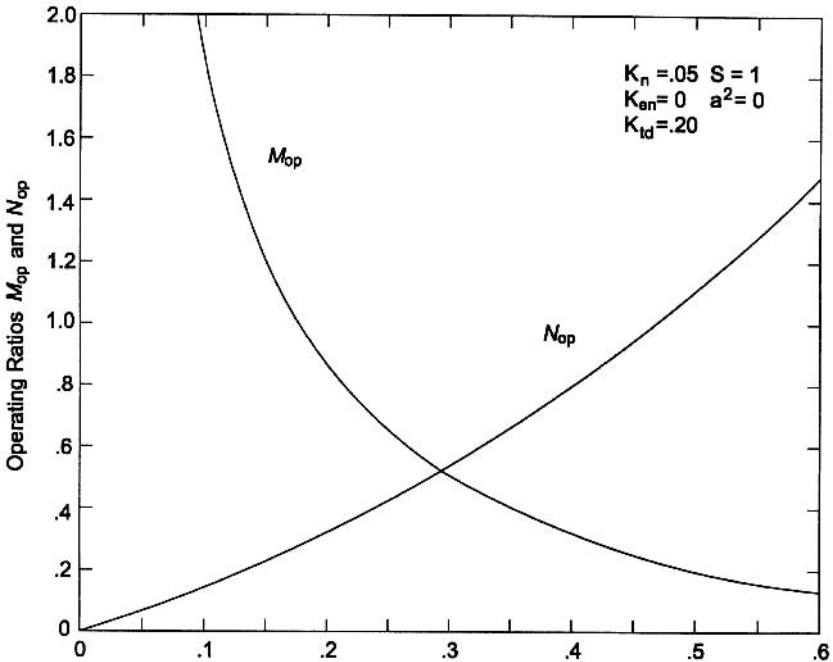
Table 2 recommendations assume that only  $P_i$ ,  $P_s$ , and  $P_d$  are utilized; if this is the case, it is necessary to assume that  $K_{en} = 0$ , as indicated. A finite value of  $K_{en}$  in Eqs. (15)–(17)

**TABLE 2** Recommended values for  $K$  friction-loss coefficients

	Range	Rec. Values	References
$K_n$	.04–1.0	.05	3, 10, 11
$K_{en}$	—	0	ditto
$K_{td}$	.17–.40	.20	ditto

**TABLE 3** Values of  $M_{op} = \frac{2}{3}M_{mep}$ , and  $N_{op}$ , for Figure 4

$b$	$M_{mep}$	$M_{op}$	$N_{op}$
0.05	4.8520	3.2347	0.0739
0.10	2.7120	1.8080	0.1509
0.15	1.8294	1.2196	0.2344
0.20	1.3330	0.8887	0.3264
0.25	1.0142	0.6760	0.4280
0.30	0.7913	0.5275	0.5406
0.40	0.5020	0.3347	0.8039
0.50	0.3270	0.2180	1.1210
0.60	0.2117	0.1411	1.4913

**FIGURE 4** Response of L/JL operating pressure ratio  $N_{op}$  and operating flow ratio  $M_{op}$  to jet pump design area ratio  $b$ 

increases the slope of the theoretical  $N(M)$  curve at low  $M$  values. At operating  $M$  values, however, this effect is negligible.

**Finding  $b$  as a Function of  $N_{op}$  or  $M_{op}$**  Figure 4 presents  $N_{op}(b)$  and  $M_{op}(b)$  for the recommended  $K$  friction coefficients of .05, 0, and .20. The Figure 4 curves are cross-plots of  $M_{op}$  values ( $=\frac{2}{3}M_{mep}$ ) and associated  $N_{op}$  values. (To find  $M_{mep}$  value at  $b$ , Eqs. (17)–(18) spreadsheets of  $\eta(M)$  and  $N(M)$  were prepared for  $b$  values covering the range .05–.6; these numerical values are provided in Table 3.) Graphical representation of the L/JL pump characteristics as shown in Figure 4 is useful in estimating  $b$  values when the jet pump application fixes  $N$  or  $M$ , and hence  $b$ . Example 3 illustrates the utility of Figure 4.



**Straight-Line  $N(M)$  Approximation** Early investigators (see Reference 2) noted a nearly linear behavior of  $N$  versus  $M$ . A “straight-line” approximation for  $N(M)$  based on the axis intercepts  $N_o$  and  $M_o$  would, of course, be useful. A true parabolic efficiency curve would result so  $M_{\text{mep}} = \frac{1}{2} M_o$ , and  $M_o$  is easily found. Unfortunately, the degree of this linearity varies with area ratio  $b$ . At about  $b = .12$ , the  $N$  curve is in fact a straight line. But as  $b$  is increased, the  $N(M)$  curve is increasingly concave down so the  $\eta = MN$  “parabolic” curve is increasingly skewed to the left. The converse is true at very small  $b$  values. Accordingly, the straight-line approximation is not recommended for use in designing LJL jet pumps. Instead, the Eqs. (17) and (18) theoretical model should be solved and charted for each  $b$ -value pump under consideration. Again, the recommended operating flow ratio  $M_{\text{op}} = \frac{2}{3} M_{\text{mep}}$ .

**Longitudinal Dimensions of the LJL Jet Pump** One-dimensional theory includes dimensions perpendicular to flow, but provides no guidance for longitudinal shapes/profiles. Two hardware dimensions of key importance must be taken from the literature or determined experimentally: nozzle-to-throat spacing “sp” and mixing throat length “L.” Both are expressed in terms of throat diameters;  $\text{sp}/D_{\text{th}}$  and  $L/D_{\text{th}}$ . Recommended values are given as follows.

**NOZZLE-THROAT SPACING** Many experimental searches for optimum sp have been reported. Sanger and Vogel both found (see References 10 and 12) that maximum efficiency (slightly above 40% for Reference 10) is obtained with  $\text{sp}/D_{\text{th}} = 0$ , using nozzles with an external concave tapering, leading to a thin lip at the outlet. This configuration matches the theoretical model: The jet discharges to pressure  $P_o$  at the throat inlet, and thus the normal jet loss was eliminated. But a zero spacing promotes cavitation, even with a thin-lipped nozzle tip, and certainly with the rounded-nose exterior profile used in Reference 4. Sanger found that retracting nozzles a distance of about one diameter provided good cavitation resistance and at only a small loss in efficiency. Other investigators have found that performance is insensitive in the range of  $\text{sp}/D_{\text{th}} = 0.5$ –2 diameters, and that small spacings do promote cavitation. (see Reference 1). *It is recommended that LJL jet pumps be designed with  $\text{sp}/D_{\text{th}} = 1$ .*

**MIXING-THROAT LENGTH** The parallel-walled throat should be long enough to allow complete mixing, but throat lengths should be as short as possible to minimize frictional losses.  $L/D_{\text{th}}$  values as well as length (a venturi shape) ranging 1.0 to 10 have been reported for LJL pumps. Several factors affect optimum throat length:

- When  $\text{sp}/D_{\text{th}}$  is finite—true for most jet pumps—mixing takes place in the distance (sp plus part or all of  $L$ , the mixing-throat length); thus, sp and  $L$  are interrelated. Sanger (see Reference 10) found that optimum  $\text{sp}/D_{\text{th}}$  increased from 0 to 2.3, for pumps with  $L/D_{\text{th}} = 7.5$  and 3.5 respectively.
- The primary-flow nozzle affects required  $L$ : Long tapered nozzles promote boundary-layer build-up producing jets that delay mixing, increasing required  $L$ . Multi-hole nozzles and swirl-inducing nozzles promote mixing and reduce required length  $L$ , but pump efficiency suffers because of increased nozzle-flow losses. (See “Primary-Flow Nozzle Design.”)
- Pump area-ratio  $b$  can affect optimum throat length. Small- $b$  pumps operate with high flow ratios and throat lengths of  $L/D_{\text{th}} = 8$  were required. For pumps with larger  $b$  values, throat lengths of four diameters sufficed (see Reference 13).
- The gas compressor jet pump (LJG) requires longer throats, as high as 10–30 throat diameters (see Reference 7).

*$L/D_{\text{th}} = 6$  is recommended for general LJL design use. Efficiency of the proposed pump may subsequently be improved by optimizing  $L$  (experimentally) for the given pump and duty.*

**PRIMARY-FLOW NOZZLE DESIGN** A short-entry internally-convex profile similar to the ASME metering flow nozzle, is recommended for the LJL pumps. Avoid long conical nozzles.

Liquid-jet flow from a sharp-edged orifice mixes readily and is recommended for the LJJ gas compressor (see Reference 7). The annular-nozzle liquid-jet pump has been investigated. In this configuration the secondary flow is axial, surrounded by the primary flow at the throat entrance. This arrangement is advantageous in pumping sticky secondary fluids because it prevents wall contact of the sticky fluid at the throat entry (see Reference 1). An obvious disadvantage is the increased nozzle frictional loss caused by flow of the primary fluid over the comparatively large surface area of the annular nozzle.

**THROAT-INLET CONTOUR** Many jet pumps reported in the early literature had long (small-convergence-angle) conical sections connecting the suction chamber to the throat, and usually including a sudden wall angle change at the throat entry. Later developments led to the short (large-convergence-angle) entry, well rounded at the throat. The long (small-angle) conical entry is wrong because its proximity to the nozzle exterior throttles the secondary flow and because it promotes cavitation. Secondly, a long approach section increases wall friction (reflected in a high  $K_{en}$  if it is measured). A short entry to the throat and a well-rounded profile connecting the suction chamber and throat is recommended.

**Laboratory Flow Tests** Performance testing of LJJ pumps requires a facility with appropriate instrumentation, pumps, flow meters, and control valves. The flow rates  $Q_1$  and  $Q_2$ , and at least three static pressures,  $P_i$ ,  $P_s$ , and  $P_d$ , must be recorded at each test point. In addition, it is recommended that the throat section(s) contain static pressure taps for measurement of  $P_i$  and  $P_s$ . Jet pump test data will then permit measurement of  $K_{en}$ ,  $K_{th}$  and  $K_{di}$ . For on-design operation, these  $K$ s vary little, if at all, with change in flow ratio  $M$ . Departures of  $K(M)$  from nominal levels serve to reveal otherwise hidden problems. One example is that  $K_{th}$  will change if an increase in flow ratio causes mixing to extend/persist from the throat section into the diffuser (inadequate throat length). Another example is that a sudden rise in  $K_{di}$  may indicate diffuser-wall separation.

## LIQUID-JET LIQUID (LJL) PUMP DESIGN EXAMPLES

Equations (1), (3), (5) and (7) will model jet pumps for LJJ, LJG and LJGL configurations. Equations (1), (11–19) apply specifically to the LJL jet pump. The three numerical examples provided here are for this widely used pump only. LJG and LJGL liquid-jet pumps are less common: please see References 5, 6 and 7.

**Example 1** Design a jet pump to handle 50 gpm (11.36 m<sup>3</sup>/h) of water at 80°F (26.7°C) from a suction at 14.7 psia atmospheric pressure (101.325 kPa) to discharge at 40 psi (275.8kPa). Determine the required primary flow rate, jet nozzle pressure and dimensions of the jet pump.

**Solution:** For best efficiency, select  $b = .25$ . From Table 2, adopt  $K_n = 0.5$ ,  $K_{di} = .20$ , and  $K_{en} = 0$ . Eq. (17) then produces  $N(M)$ . A computer spreadsheet table for Eqs. (17) and (18) showing output values based on increments of  $M$  is recommended, for example, see Table 1. As shown by the bottom line in Table 1, the  $M_{mep} = 1.104$  (found by successive approximations using the spreadsheet program). The operating flow ratio is  $M_{op} = \frac{2}{3}M_{mep} = .676$ . The spreadsheet program at this  $M_{op}$  produces the  $N_{op}$  (.428) and  $\eta$ (28.934%) values shown in Table 1, second line from the bottom. From Eq. 19  $(P_d - P_s)/P_i - P_s = N/(N + 1)$ , so and  $P_i - P_s = (1.428/.428)40 = 1.3346$  psi (920.212 kPa). Thus  $P_i = 1.3346 + 14.7 = 148.16$  psia (1021.56kPa). Liquid jet pumps—with very few exceptions—operate with the nozzle tip withdrawn from the throat entry by one throat-diameter or more. The nozzle tip experiences a discharge pressure close to  $P_s$ , not  $P_o$ , and “jet loss” thus occurs. For this jet loss condition, Eq. (1) changes to  $(P_i - P_s) = Z(1 + K_n)$ . The jet velocity head  $Z = 1.3346/1.05 = 1.2710$  psi (876.35kPa).

**CAVITATION-LIMITED FLOW RATIO  $M_L$**  The flow ratio  $M_L$  is now evaluated using Eq. (20) to answer the question: will  $M_{op} = .676$  avoid pump cavitation? The area ratio  $c = (1 - .25)/$

.25 = 3. For the secondary fluid (water at 80°F, 26.7°C),  $P_v = .506$  psia (3.49 kPa). The conservative value of  $\sigma = 1.35$  is used in Eq. (20) as follows:

$$M_L = 3\sqrt{\frac{14.7 - .506}{1.35 \times 1.2710}} = .863$$

Because  $M_{op} (.676) < M_L (.863)$ , this pump will not cavitate at the specified operating condition.

JET PUMP DIMENSIONS  $Q_1 = Q_2/M_{op} = 50/.676 = 73.96$  gpm (16.8 m<sup>3</sup>/h) = 73.96/(7.481 × 60) = .165 ft<sup>3</sup>/s. Longitudinal dimensions:  $sp/D_{th} = 1.0$ , thus  $sp = .937$  in (23.81 mm). For  $L/D_{th} = 6$ ,  $L = 6 \times .937 = 5.62$  in (142.75 mm). A diffuser with an included angle of 5° (conservative) and area ratio  $a = .224$  would have length of approximately 12 in (304.8 mm). A shorter diffuser may be desirable, but kinetic-energy leaving losses will be higher.

EXAMPLE 1 USING OTHER AREA RATIOS An infinite number of different jet pumps can be designed to handle the Example 1 duty of pumping 50 gpm at 40 psi discharge pressure. The previous numerical example ( $b = .25$ ) was repeated using  $b = .1, .4$ , and  $.6$ . Table 4 compares the results of these four  $b$ -ratio pumps. In each case the design is based on  $M_{op} = \frac{2}{3}M_{mep}$ ; the assumed  $K$  values and calculation procedure are similar for the four pumps.

The expression CR% in Table 4 indicates the  $(M_L - M_{op})/M_{op}$  % separation of operating flow ratio  $M_{op}$  and the limiting flow ratio  $M_L$ ; the larger this number, the better. For this constant-duty example ( $Q_2 = 50$  gpm and  $P_d = 40$  psi), Table 4 shows that cavitation resistance can be improved by using a larger  $b$  ratio, i.e., the  $(M_L - M_{op})/M_{op}$  % figure increases with  $b$ . Note that at the smallest  $b$  value (.1), the cavitation value (sixth column) is CR = -5.3%: this indicates that  $M_{op} > M_L$ , and this pump *would* encounter cavitation:  $b = .1$  should not be used at these  $M_{op}$  and  $\sigma$  values. A redesign of the pump suction chamber (nozzle-external profile and throat-inlet profile) leading to an improvement in cavitation coefficient  $\sigma$  could render the  $b = .1$  pump usable (the value  $\sigma = 1.35$  used previously is conservative). For example, an improvement to  $\sigma = 1.0$  would raise  $M_L$  to 2.0. With this change, a  $b = .1$  pump could be used, cavitation-free.

Table 4 shows two other important facts: (1) The  $b = .25$  pump provides the highest efficiency, even though all four are designed to operate at  $\frac{2}{3}M_{mep}$ , i.e., each at a similar position on the efficiency curve specific to that pump. (2) Small  $b$ -value pumps operate at large nozzle pressure-drops ( $P_i - P_s$ ) and with small  $Q_1$  primary-values. Conversely, high  $b$ -value pumps operate with small nozzle pressure-drops, but use a large flow rate  $Q_1$ . The pumps have in common similar expenditures of energy ( $Q_1 \times$  pressure change, and allowing for efficiency differences) to handle the duty, which is the same in all four cases. In some design problems the nozzle-pressure—or possibly the primary-fluid flow volume—might outweigh the importance of mechanical efficiency. Table 4 shows how an adjustment in  $b$  might be used to achieve improved cavitation, albeit with efficiency sacrifices.

REDUCING THE FLOW RATIO  $M_{op}$  TO COPE WITH CAVITATION For a given  $b$ -value L<sub>J</sub>L jet pump, a reduction in  $M_{op}$  offers a way to improve cavitation resistance. The  $b = .1$  pump used

**TABLE 4** Four  $b$ -value jet pumps for duty of 50 gpm (11.35 m<sup>3</sup>/h) at  $P_d = 40$  lb/in<sup>2</sup> (275 kPa)

$b$	$M_{op}$	$N_{op}$	$\eta\%$	$M_L$	CR%	$(P_i - P_s)$ , lb/in <sup>2</sup>	$Q_1$ , gpm	$D_n$ , in
0.10	1.8080	0.1509	27.28	1.7122	-5.30	305.08	27.65	0.233
0.25	0.6760	0.4280	28.93	0.8628	27.65	133.46	73.96	0.469
0.40	0.3347	0.8039	26.91	0.5261	57.19	89.76	149.39	0.736
0.60	0.1411	1.4913	21.04	0.2711	92.13	66.82	354.36	1.219

[Note: for SI conversion: in × 25.4 = mm]

**TABLE 5** Reducing  $M_{op}$  improves CR% cavitation resistance ( $b = .1$ )

$M_{op}$	$N_{op}$	$\eta\%$	$M_L$	CR%	$(P_i - P_s)$ , lb/in <sup>2</sup>	$Q_1$ , gpm	$D_n$ , in
1.808	0.1509	27.28	1.7122	-5.30	305.08	27.65	0.233
1.500	0.1631	24.46	1.7704	18.01	285.08	33.33	0.260
1.000	0.1823	18.23	1.8566	85.67	259.45	50.00	0.326
0.500	0.2006	10.03	1.9326	286.56	239.36	100.00	0.471

[For SI conversions: lb/in<sup>2</sup>  $\times$  6.89 = kPa; gpm  $\times$  0.277 = m<sup>3</sup>/h; in  $\times$  25.4 = mm]

in this example is examined for the effects of  $M_{op}$  reduction, in Table 5. The conditions for all four pumps in Table 5 are  $b = .1$ , and again,  $K_n = .05$ ,  $K_{td} = .2$ ,  $K_{en} = 0$ . The Table 5 top line is  $M_{op} = 1.808$ , followed by three .5 decrements of  $M_{op}$ . The corresponding  $N_{op}$  and  $\eta_{op}$  values are found from successive approximations using the spreadsheet based on Eqs. (17) and (18). The  $M_L$  values are calculated from Eq. (20). The CR% cavitation merit figure (5th column) is the same as used in Table 4. Table 5 shows that while a  $b = .1$  pump at  $M_{op} = 1.808$  flow ratio will cavitate, the three lower  $M_{op}$  cases all exhibit increased CR% cavitation resistance. In Table 5,  $M_L$  (4th column) changes little with  $M_{op}$ ; the cavitation improvements largely result from the decreases in  $M_{op}$ . The primary flow rate  $Q_1$  increases markedly, and the nozzle pressure decreases somewhat as  $M_{op}$  is reduced. Compared with adjustment in  $b$ , cavitation avoidance by reducing  $M_{op}$  has obvious disadvantages: Efficiency is severely reduced, and the pump size (see  $D_n$ , 8th column) must be increased to handle the larger flow  $Q_1$ .

In summary, every jet pump design should be evaluated for cavitation resistance. The CR% index used here ( $(M_L - M_{op})/M_{op}$  %) is suggested if several options are to be compared. Otherwise, the simpler test  $M_{op} < M_L$  is adequate. Cavitation resistance for a given pump duty can be improved by increasing the area ratio  $b$ , or by reducing  $M_{op}$  of a particular pump, or by reducing the cavitation coefficient  $\sigma$  by improved internal design.

**Example 2** Design a jet pump to lift 80°F (27.67°C) water to 20 ft (6.1m) to discharge at an atmospheric pressure of 14.7 psia or 34 ft of water (10.3 m). A mechanical pump provides the primary flow stream; fluid power available at the jet pump is 10 kW. Find the secondary flow  $Q_2$ , and pump dimensions.

**Solution:** Assume the same K values used in Example 1. Again select  $b = .25$ , for maximum efficiency. Eq. 17 (via spreadsheet program) produces  $M_{mep} = 1.014$  and  $M_{op} = \frac{2}{3}(1.014) = 6.76$ , where  $N_{op} = .428$  and  $\eta = 28.93\%$ .  $P_s = (34-20) = 14$  ft water abs. (4.261 m abs.) at the suction chamber. And  $P_s = 14 \times 1.934 \times 32.174/144 = 6.05$  psia (41.72 kPa).  $(P_d - P_s) = (14.7 - 6.05) = 8.65$  psi (59.64 kPa). From Eq. 19,  $(P_i - P_s) = (P_d - P_s)(N + 1)/N$ , so that  $(P_i - P_s) = (14.7 - 6.05)(1.428/.428) = 28.86$  psi (199 kPa).  $P_i = 28.86 + 6.05 = 34.91$  psia (40.7 kPa).  $Z = (P_i - P_s)/(1 + K_n) = 28.86/1.05 = 27.486$  psi (189.52 kPa).

*Cavitation-Limited Flow Ratio  $M_L$*       Limiting flow ratio (Eq. 20)

$$M_L = 3\sqrt{\frac{6.05 - .506}{1.35 \times 27.486}} = 1.16$$

Because  $M_{op} (.676) < M_L (1.16)$ , the proposed L JL jet pump will not cavitate.

JET PUMP DIMENSIONS Power in =  $Q_1(P_i - P_j)$ ;  $Q_1$  = power in/ $(P_i - P_j)$ , where  $(P_i - P_j) = (34.91 - 14.7) = 20.21$  psi. With 10 kW treated here as the net "fluid" power available at the nozzle. (In Figure 2 the jet and mechanical pumps are at the same elevation)

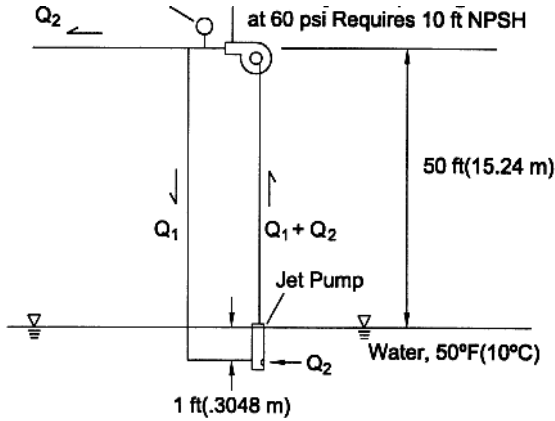


FIGURE 5 Jet and centrifugal pump system, for Example 3

$$Q_1 = \frac{10 \times 7.481 \times 60}{1.356 \times 10^{-3} \times 144 \times 20.21} = 1137.42 \text{ gal/min (258.6 m}^3\text{/h)}$$

(conversion factors 7.481 gal/ft<sup>3</sup> and 1.356 watts/ft-lb/s were used previously)

Secondary flow  $Q_2 = 1137.42 \times .676 = 768.9 \text{ gpm (174.6 m}^3\text{/h)}$ .

Nozzle area:

$$A_n = \frac{Q_1}{V_n}, \text{ where } V_n = \sqrt{2 \times 27.476 \times \frac{144}{1.934}} = 64 \text{ ft/s (19.51 m/s)}$$

$$A_n = (768.9 \times 144) / (64 \times 7.481 \times 60) = 3.85 \text{ in}^2 (24.84 \text{ cm}^2)$$

Nozzle diameter:

$$D_n = \sqrt{3.85 \times \frac{4}{3.1416}} = 2.22 \text{ in (56.39 mm)}$$

**Example 3** As shown in Figure 5, a surface-mounted centrifugal pump requires a NPSH of 10 ft (3 m) of water, and the centrifugal-pump discharge pressure is 60 psi (414 kPa) at 100 gpm (22.7 m<sup>3</sup>/h). Water at 50°F (10°C) is to be lifted 50 ft (15.2 m). Design the jet pump including dimensions, and find the primary and secondary flow rates.

**Solution:** The jet pump's placement and centrifugal-pump discharge and inlet pressures determine all three jet-pump operating pressures, and hence the pressure characteristic  $N$ .

$$P_i = 60 \text{ psi} + (50 + 1) \times 1.94 \times 32.17/144 = 82.1 \text{ psi (566.1 kPa)}$$

$$P_s = 1 \times 1.94 \times 32.17/144 = .433 \text{ psi (299kPa)}. P_d = (50 + 10) \times$$

$$1.94 \times 32.17/144 = 26 \text{ psi (179.27 kPa)}. N_{op} = (P_d - P_s)/(P_i - P_d) = .456.$$

To estimate the  $b$  level which will operate at this  $N$ , enter Figure 4 with  $N_{op} = .46$ : the corresponding  $b = .27$ , and  $M_{op} = .62$ . Estimate  $b$  values should be confirmed—and adjusted if necessary—using a spreadsheet solution based on Eqs (17) and (18). In this case the

spreadsheet results are  $N_{op} = .461$ ,  $b = .265$ ,  $M_{op} = .626$ , and  $\eta = 28.8\%$ . The cavitation check and calculation of dimensions follow next. *Note:* This solution is a first estimate because piping frictional losses have not been included in the calculations. Second and third—if necessary—calculations must include the pressure losses in the piping connecting the two pumps.

CAVITATION LIMITED FLOW RATIO  $M_L$  Jet velocity head  $Z = (P_i - P_s)/(1 + K_n) = (82.1 - .433)/(1 + .05) = 77.78$  psi (536.29kPa).

For water at 50°F (10°C),  $P_v = .178$  psia (1.23 kPa)

$$M_L = c\sqrt{\frac{P_s - P_v}{\sigma}} \times Z = 2.774\sqrt{\frac{15.133 - .178}{1.35}} \times 77.78 = 1.047$$

Because  $M_{op} (.626) < M_L (1.047)$ , the jet pump will not cavitate at the operating point.

JET PUMP DIMENSIONS  $Q_1 + Q_2 = 100$  gpm (19.71 m<sup>3</sup>/h), and  $Q_2/Q_1 = .626$ , so  $Q_1 = 61.5$  and  $Q_2 = 38.5$  gpm (12.12 and 7.59 m<sup>3</sup>/h).  $A_n = Q_1/V_n$ .

Jet velocity:

$$V_n = \sqrt{\frac{2Z}{\rho_1}} = \sqrt{\frac{2 \times 77.8}{1.94}} = 107.46 \text{ ft/s (32.75 m/s)}$$

$$Q_1 = 61.5/7.481 \times 60 = .137 \text{ ft}^3/\text{s} (13.97 \text{ m}^3/\text{h})$$

$$\text{Nozzle area } A_n = (.137/107.46)144 = 1.87 \text{ in}^2 (1.187 \text{ cm}^2).$$

Nozzle diameter:

$$D_n = \sqrt{\frac{4 \times A_n}{\pi}} = \sqrt{\frac{4(.184)}{3.1416}} = .483 \text{ in (12.27 mm)}.$$

Throat diameter:

$$D_{th} = \frac{D_n}{\sqrt{b}} = \frac{.483}{.515} = .938 \text{ in (23.83 mm)}$$

Nozzle-throat spacing recommended:  $sp/D_{th} = 1$ , hence  $sp = .938$  in (23.83 mm)

Mixing-throat length recommended:  $L/D_{th} = 6$ , hence  $L = 6 (.938) = 5.63$  in (143 mm)

**Centrifugal-Jet-Pump Interactions** Oil- and water-well pumping are major applications of L/JL pumps. Compact jet pumps, lowered down the bore hole near to or below the liquid surface, are powered by primary flow supplied from a mechanical pump located above, at the earth's surface. The jet pump pressurizes the surface pump's suction preventing cavitation. The design of a combination pump system normally requires designing for operation at the intersection of the two pumps' operating curves (Refs. 17, 18, and 19) and of course inclusion of frictional losses (neglected in Example 3) in the associated piping. One operating point (100 gpm at 60 psi) in Example 3 represented the centrifugal pump. The 60 psi discharge pressure of the centrifugal pump and the vertical placement fixed the jet pump's  $N_{op}$  operating point. This in turn determined the jet pump's  $b$  value. Consider now a change in the centrifugal pump to one providing 100 gpm at 100 psi (22.7 m<sup>3</sup>/h at 6.89 kPa): the jet pump's  $N_{op}$  (and  $b$ ) would be reduced, and  $M_{op}$  raised. Details are omitted here, but the resultant area ratio would be about  $b = .167$ , which would provide  $M_{op} = 1.09$ , a considerable increase over  $M_{op} = .626$ , as found in Example 3.

### SIGNIFICANCE OF ON-DESIGN OPERATING CONDITIONS

---

With reference to Figure 3, assume that the pump is operating on-design at  $M_{op} = \frac{2}{3}M_{mep}$ ; that is, on the left branch of the efficiency “parabola.” Primary flow rate  $Q_1$  and suction pressure  $P_s$  are constant. If the back pressure  $P_d$  is then *reduced*, the secondary flow rate  $Q_2$  (and hence  $M_{op}$ ) will rise and pressure ratio  $N_{op}$  will fall. The new operating points will move to the right, along the characteristic curves for  $N$  and  $\eta$ . This increased-flow response to lowered  $P_d$  will end when cavitation-limited flow ratio  $M_L$  is reached, assuming the NPSH is low enough to allow cavitation. Any further reduction of  $P_d$  will cause the operating points to leave the  $N$  and  $\eta$  theoretical curves on paths vertically downward as shown by the dashed line in Fig. 3. Consider next the same initial condition (on design:  $M_{op} = \frac{2}{3}M_{mep}$ ) followed by an *increase* in jet-pump discharge pressure  $P_d$ . In response, the secondary flow  $Q_2$  (and hence  $M$ ) will decrease, the  $N_{op}$  and  $\eta_{op}$  operating points moving left along the pump’s  $N$  and  $\eta$  characteristic curves. Ultimately, increasing the back-pressure will result in reaching the  $M = 0$  point, where  $N = N_o$ . (See Table 1, showing  $N = N_o = .680$  at  $M = 0$ .)

Mechanical efficiency is important in most jet pump installations. Two low-efficiency situations that should obviously be avoided are

- Throttling the pump discharge pressure (to raise the  $P_d$  to the design point) wastes energy. Design  $P_d$  should match the pressure of the system into which the pump is to discharge.
- Operating the L<sub>J</sub>L pump with a discharge pressure  $P_d$  less than the design  $P_d$  (same  $Q_1$  and  $P_s$ ) will yield more  $Q_2$  flow ( $M > M_{op}$ ) and slightly higher efficiency. But such an increase in  $M$  may reach the cavitation point, that is, where  $M = M_L$ , causing a marked departure of actual/measured operating points downward from the  $N$  and  $\eta$  characteristic curves.

### OTHER JET PUMP APPLICATIONS

---

Virtually any fluid can be pumped by the liquid-jet pump. Suspensions of solids in a liquid can be handled with the L<sub>J</sub>L analysis given by incorporating the “S” density-ratio term. In extreme cases, slurry pumping may also be affected by slip velocity and solids concentration (see References 1 and 15).

Steam jet pumps are found in the earliest literature (see Reference 1). Analyses have usually combined one-dimensional treatment with shock-wave compressibility phenomena. Theory has not contributed to the longitudinal dimensions problem, as is the case with liquid jet pumps. Advances in applying two- and three-dimensional flow theory have contributed to understanding low Mach-number mixing length requirements. Air/air jet pump theory and performance have been compared (see Reference 16). Analysis of high-velocity compressible-flow gas-jet pumps has been less successful.

Design of a two-pump combination system (illustrated by Examples 2 and 3) required system operation at an intersection of the mechanical- and jet-pump characteristic curves, selected so both pumps operate at or near their maximum efficiency points (see References 17, 18 and 19). And the system design must of course include consideration of the pressure losses that will occur in the piping connecting the two pumps.

### REFERENCES

---

1. Bonnington, S. T., and King, A. L. “Jet Pumps and Ejectors: A State of the Art Review and Bibliography.” Published by BHRA Fluid Engineering, Cranfield, Bedfordshire MK43 OAJ, United Kingdom, 1976.
2. Gosline, J. E., and O’Brien, M. P. “The Water Jet Pump.” *University of California Publications in Engineering*, v. 3, pp. 167–190, 1934.



3. Cunningham, R. G. "Jet Pump Theory and Performance with Fluids of High Viscosity." *Trans. ASME*, v. 79, pp. 1807–1820, 1957.
4. Mueller, N. H. G. "Water Jet Pump." *Proceedings ASCE, Journal of the Hydraulics Division*, v. 90, pp. 83–113, 1964.
5. Cunningham, R. G. "Liquid Jet Pumps for Two-Phase Flows." *Trans. ASME, Journal of Fluids Engineering*, v. 117, pp. 309–316, 1995.
6. Cunningham, R. G. "Gas Compression with the Liquid Jet Pump." *Trans. ASME, Journal of Fluids Engineering*, v. 6, pp. 203–315, 1974.
7. Cunningham, R. G., and Dopkin, R. J. "Jet Breakup and Mixing Throat Lengths for the Liquid Jet Gas Pump." *Trans. ASME, Journal of Fluids Engineering*, v. 94, pp. 216–226, 1974.
8. Cunningham, R. G., Hansen, A. G., and Na, T. Y. "Jet Pump Cavitation." *Trans. ASME, Journal of Basic Engineering*, v. 92, pp. 483–494, 1970.
9. Cunningham, R. G. "Liquid Jet Pump Modeling: Effects of Axial Dimensions on Theory-Experiment Agreement." *Proceedings: Second Symposium on Jet Pumps and Ejectors*, BHRA Fluid Engineering, Cranfield, Bedfordshire MK43 OAJ, United Kingdom, 1975.
10. Sanger, N. L. "An Experimental Investigation of Several Low-Area-Ratio Water Jet Pumps." *Trans. ASME, Journal of Basic Engineering*, v. 92, pp. 11–20, 1970.
11. Na, T. Y. "Performance of Liquid Jet Pumps at Elevated Temperatures." *Proceedings: Symposium on Jet Pumps and Ejectors*, BHRA Fluid Engineering, Cranfield, Bedfordshire MK43 OAJ, United Kingdom, 1972.
12. Vogel, R. "Theoretical and Experimental Investigations on Jet Devices." *Maschinenbautechnik*, v. 5, pp. 619–637, 1956.
13. Schulz, F., and Fasol, K. H. *Wasserstrahlpumpen zur Forderung von Flussigkeiten*. Published by Springer-Verlag, Vienna, 73 pages, 1958.
14. Hoggarth, M. L. "The Design and Performance of High Pressure Injectors as Gas Jet Boosters." *Proceedings: I. Mech. E.*, v. 185, pp. 755–766, 1970–71.
15. Bonnington, S. T. *Jet Pumps*. (Handling solid-liquid mixtures), SP 529, BHRA Fluid Engineering, Cranfield, Bedfordshire MK43 OAJ, United Kingdom, 1956.
16. Razinsky, E., and Brighton, J. A. "A Theoretical Model for Nonseparated Mixing of A Confined Jet." *Trans. ASME Series D*, v. 94, pp. 551–558, 1972.
17. Hansen, A. G., and Na, T. Y. "Optimization Jet Pump Systems." ASME Paper 66-FE 4, April 1966.
18. Radha Kirishna, H. C., and Kumaraswamy, S. "Some Investigations on the Combination Performance of Jet-Centrifugal Pump." *Proceedings: Second Symposium on Jet Pumps and Ejectors and Gas Lift Techniques*, BHRA Fluid Engineering, Cranfield, Bedfordshire MK43 OAJ, United Kingdom. Paper B-1, March 1975.
19. Radha Kirishna, H. C., and Kumaraswamy, S. "Matching the Performance of Jet and Centrifugal Pumps." *Proceedings: Second Symposium on Jet Pumps and Ejectors and Gas Lift Techniques*, BHRA Fluid Engineering, Cambridge, UK. Paper B-3, March 1975.



---

# SECTION 4.2

---

# JET PUMP APPLICATIONS

---

ALEX M. JUMPETER

This section contains extensive design and application experience for a variety of jet pump configurations. Although this section concentrates on eductors (termed L<sub>J</sub>L jet pumps in Section 4.1), experience with other motive (primary) and secondary fluids is also included. The theoretical developments of Section 4.1 are the basis for what is presented here, the dimensional design ratios being generally within the ranges mentioned therein. Therefore, the only theory in this section is the empiricism that is utilized in the examples and applications presented. Refer to Section 4.1 for further explanation.

---

## DEFINITION OF TERMS

---

A definition of standard ejector terminology is as follows:

<i>Ejector</i>	General name used to describe all types of jet pumps that discharge at a pressure intermediate between motive and suction pressures.
<i>Eductor</i>	A liquid jet pump using a liquid as motive fluid.
<i>Injector</i>	A particular type of jet pump that uses a condensable gas to entrain a liquid and discharge against a pressure higher than either motive or suction pressure; principally, a boiler injector.
<i>Jet Compressor</i>	A gas jet pump used to boost pressure of gases.
<i>Siphon</i>	A liquid jet pump utilizing a condensable vapor, normally steam, as the motive fluid.

## EDUCTORS

**Design** The elements of an eductor design are shown in Figure 1. Quantities involved are defined as follows:

$P_1$  = static pressure upstream, lb/ft<sup>2</sup> (N/m<sup>2</sup>)

$P_s$  = static pressure at suction (nozzle tip), lb/ft<sup>2</sup> (N/m<sup>2</sup>)

$V$  = velocity, ft/s (m/s)

$\gamma_1$  = specific weight (force) of motive fluid, lb/ft<sup>3</sup> (N/m<sup>3</sup>)

$$\frac{P_1 - P_s}{\gamma_1} = \text{operating head, ft (m)}$$

$P_s$  = static pressure at suction, lb/ft<sup>2</sup> (N/m<sup>2</sup>)

$P_2$  = static pressure at discharge, lb/ft<sup>2</sup> (N/m<sup>2</sup>)

$\gamma_2$  = specific weight (force) of mixed fluids, lb/ft<sup>3</sup> (N/m<sup>3</sup>)

$$\frac{P_2 - P_s}{\gamma_2} = \text{discharge head, ft (m)}$$

The head ratio  $R_H$  is defined as the ratio of the operating head to the discharge head:

$$R_H = \frac{(P_1 - P_s)/\gamma_1}{(P_2 - P_s)/\gamma_2} = \frac{(P_1 - P_s)\gamma_2}{(P_2 - P_s)\gamma_1} \quad (1)$$

Because ratios are involved, it is convenient to replace specific weight with specific gravity:

$$R_H = \frac{(P_1 - P_s)(\text{sp. gr.}_2)}{(P_2 - P_s)(\text{sp. gr.}_1)} \quad (2)$$

When the suction and motive fluids are the same, no gravity correction is required and Eq. 2 becomes

$$R_H = \frac{H_1 - H_s}{H_2 - H_s} \quad (3)$$

where  $H_1 - H_s$  = operating head, ft (m)

$H_2 - H_s$  = discharge head, ft (m)

Entrainment relates the mass (flow rate) of motive fluid and suction fluid:

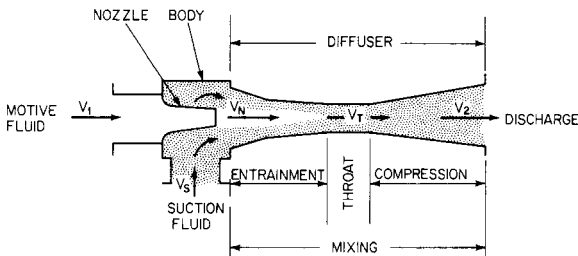


FIGURE 1 Eductor elements and terminology

$M_1$  = mass of motive (primary) fluid, slugs (kg)

$M_s$  = mass of suction (secondary) fluid, slugs (kg)

$$R_w = \frac{M_s}{M_1} = \text{the weight operating ratio} \quad (4)$$

The volume ratio  $R_v$  is then simply

$$\frac{Q_s}{Q_1} = R_w \frac{\text{sp. gr.}_1}{\text{sp. gr.}_2} \quad (5)$$

where  $Q_s$  = suction (secondary) flow in volumetric units

$Q_1$  = motive (primary) flow in volumetric units

The performance of eductors is expressed here in terms of  $R_H$  and  $R_w$ , utilizing an empirical relationship that involves an efficiency factor  $\epsilon$  as follows:

$$R_w = \epsilon \sqrt{R_H} - 1 \quad (6)$$

This equation is used to calculate the motive quantity or pressure from the operating parameters. This nozzle and diffuser diameters are calculated from the equation  $Q = wAV$ , using suitable nozzle and diffuser entrance coefficients. The principal problems in design concern the size and proportions of the mixing chamber, the distance between nozzle and diffuser, and the length of the diffuser. Eductor designs are based on theory and empirical constants for length and shape. The most efficient units are developed from calculated designs that are then further modified by prototype testing.

Figure 2 shows this factor plotted against  $NPSH$  (net positive suction head) for a single-nozzle and annular-nozzle eductor. In an annular-nozzle eductor, the motive fluid is introduced around the periphery of the suction fluid, either by a ring of nozzles (Figure 15) or by an annulus created between the inner wall of the diffuser and the outer wall of the suction nozzle (Figure 14). The  $NPSH$  is the head available at the centerline of the eductor to move and accelerate suction fluid entering the eductor mixing chamber.  $NPSH$  is the total head in feet (meters) of fluid flowing and is defined as atmospheric pressure minus suction pressure minus vapor pressure of suction or motive fluid, whichever is higher.

Increased viscosity of motive or suction fluid increases the frictional and momentum losses and therefore reduces the efficiency factor of Figure 2. Below 20 cP, the effect is minimal (approximately 5% lowering of  $\epsilon$ ). Above this value, the loss of performance is more noticeable and empirical data or pilot testing is used to determine sizing parameters.

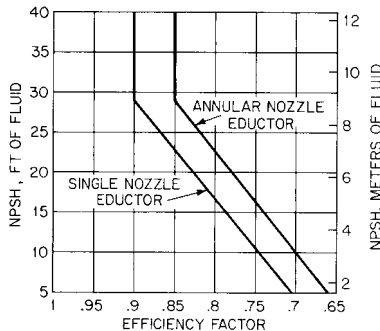


FIGURE 2 NPSH versus efficiency factor (Schutte and Koerting)

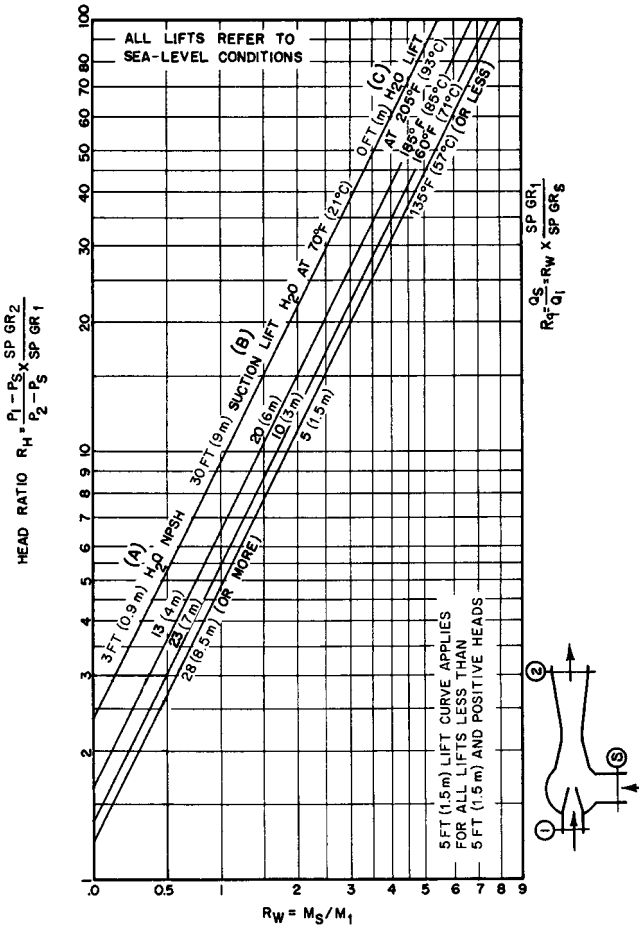


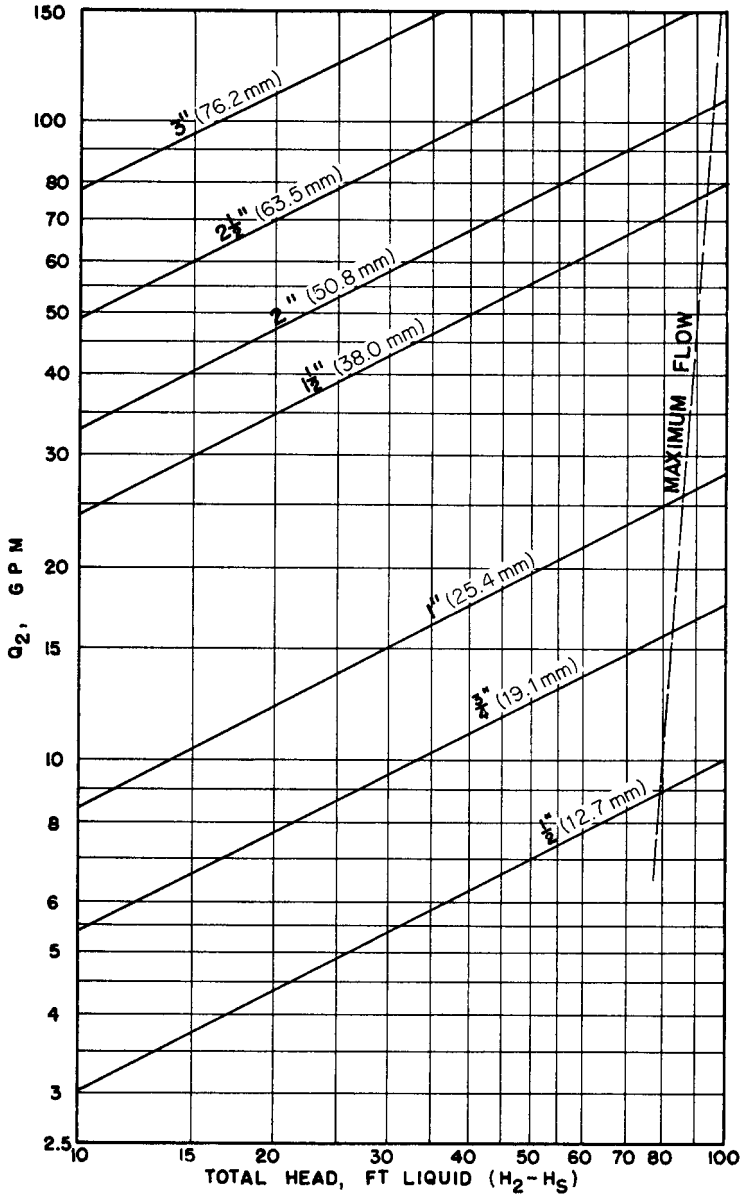
FIGURE 3 Estimating operating ratios for liquid jet eductors. An eductor can be designed for only one head point (Schutte and Koerting)

Figure 3 shows the operating ratio  $R_w$  versus the head ratio  $R_H$  for various lift conditions. The efficiency factor has been incorporated into this curve.

The final size of the eductor is determined by the discharge line and is based on normal pipeline velocities, which are usually 3 to 10 ft/s (0.9 to 3 m/s). Figure 4a and 4b are used for estimating eductor size. To illustrate the use of Figures 3 and 4, consider the following example.

**EXAMPLE 1** It is desired to remove 100 gpm (22.7 m<sup>3</sup>/h) of water at 100°F (38°C) from a pit 20 ft (6.1 m) deep. Discharge pressure is 10 lb/in<sup>2</sup> (0.69 bar\*) gage. Motive water is available at 60 lb/in<sup>2</sup> (4.1 bar) gage and 80°F (26.6°C). The eductor is to be located above the pit. Find the eductor size and motive water quantity required.

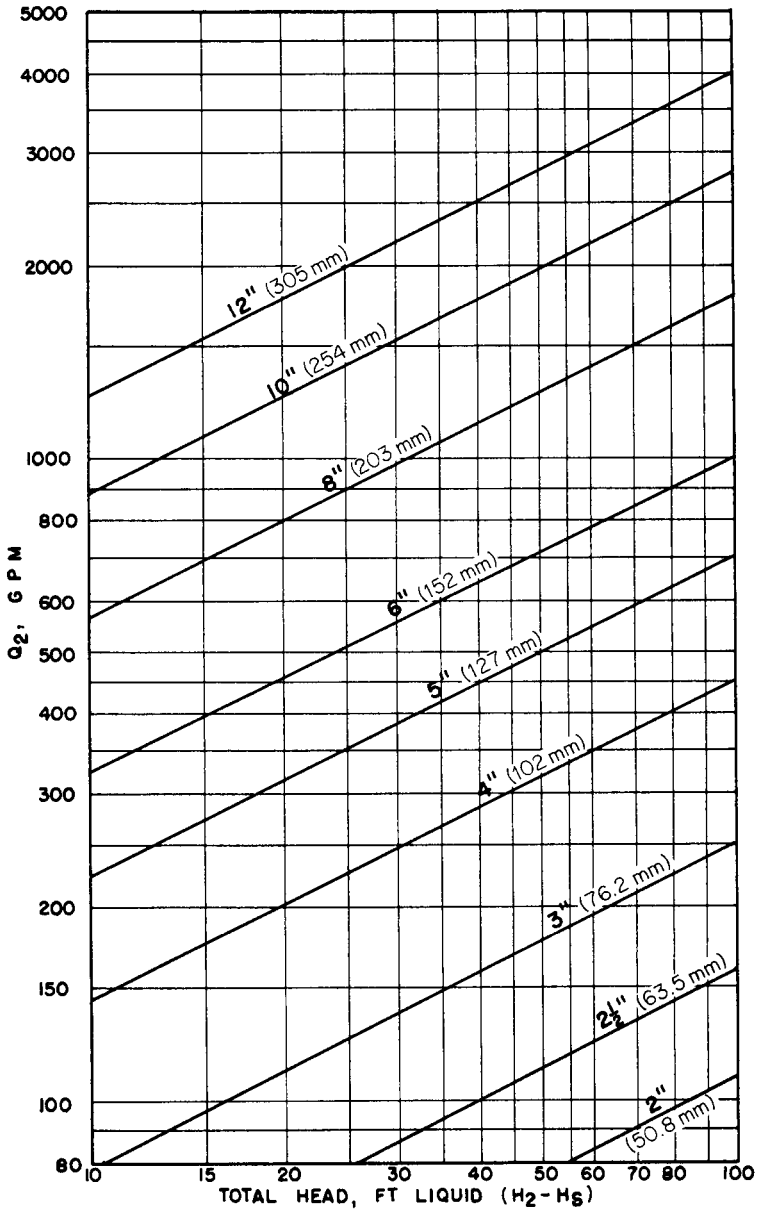
\*1 bar = 10<sup>5</sup> Pa. For a discussion of bar, see *SI Units—A Commentary* in the front matter.



(a)

FIGURE 4A Sizing curve (gpm  $\times$  0.227 = m<sup>3</sup>/h; ft  $\times$  0.3048 = m)

*Solution* To use Figure 3, it is necessary to determine the *NPSH* and the head ratio  $R_H$ . The centerline of the eductor is chosen as the datum plane, and *NPSH* is taken to be atmospheric pressure minus suction lift minus vapor pressure at 100°F (38°C):



(b)

FIGURE 4B Sizing curve (continued)

$$\text{in USCS units} \quad NPSH = 34 \text{ ft} - 20 \text{ ft} - 1.933 \text{ inHg} \left( \frac{13.6}{12} \right) = 11.81 \text{ ft}$$

$$\text{in SI units} \quad NPSH = 10.36 \text{ m} - 6.1 \text{ m} - 49 \text{ mmHg} \left( \frac{13.6}{1000} \right) = 3.59 \text{ m}$$

Because motive and suction are the same fluid, it is convenient to work in feet (meters) rather than pounds per square inch (bar), and

$$P_1 = 60 \text{ lb/in}^2 \text{ gage} = 138.6 \text{ ft H}_2\text{O} \text{ (4.1 bar} = 42 \text{ m)}$$

$$P_2 = 10 \text{ lb/in}^2 \text{ gage} = 23.1 \text{ ft H}_2\text{O} \text{ (0.69 bar} = 7 \text{ m)}$$

$$P_s = -20 \text{ ft} \text{ (-6.1 m)}$$

Then

$$\text{in USCS units} \quad R_H = \frac{138.6 - (-20)}{23.1 - (-20)} = \frac{158.6}{43.1} = 3.68$$

$$\text{in SI units} \quad R_H = \frac{42 - (-6.1)}{7 - (-6.1)} = 3.68$$

Enter Figure 3 at  $R_H = 3.68$  and  $NPSH = 11.81$  (3.59 m); read  $R_w = 0.48$ . Because there is no gravity correction,

$$\text{in USCS units} \quad R_w = R_q = \frac{0.48 \text{ gal suction}}{\text{gal motive}}$$

$$\text{in SI units} \quad R_w = R_q = \frac{0.48 \text{ m}^3 \text{ suction}}{\text{m}^3 \text{ motive}}$$

The same result can be obtained by using the efficiency factor from Figure 2. Then  $R_w$  is  $0.77\sqrt{R_H} - 1 = 0.48$  and the required motive fluid is

$$\text{in USCS units} \quad \frac{100 \text{ gpm suction}}{0.48} = 208 \text{ gpm at } 60 \text{ lb/in}^2 \text{ gage}$$

$$\text{in SI units} \quad \frac{22.7 \text{ m}^3/\text{h}}{0.48} = 47.3 \text{ m}^3/\text{h at } 4.1 \text{ bar gage}$$

Discharge flow is

$$\text{in USCS units} \quad 208 + 100 = 308 \text{ gpm}$$

$$\text{in SI units} \quad 47.3 + 22.7 = 70.0 \text{ m}^3/\text{h}$$

The size is obtained from Figure 4. Enter Figure 4b at  $Q_2 = 308$  gpm (70 m<sup>3</sup>/h) and discharge head ( $H_2 - H_3$ ) = 23.1 - (-20) = 43.1 ft [7 - (-6.1) = 13.1 m]; read eductor size of 4 in (102 mm) based on the discharge connection.

NOTE: If there were any appreciable length of run on the discharge line, it would be necessary to calculate the pressure drop in this line and recalculate the eductor size after adding the line loss to the discharge head required. Frictional losses on the suction side must also be included. In the example chosen, however, 100 gpm (22.7 m<sup>3</sup>/h) in a 4-in (102-mm) suction line 20 ft (6.1 m) long will have negligible frictional loss, less than 0.25 ft (0.08 m) H<sub>2</sub>O.

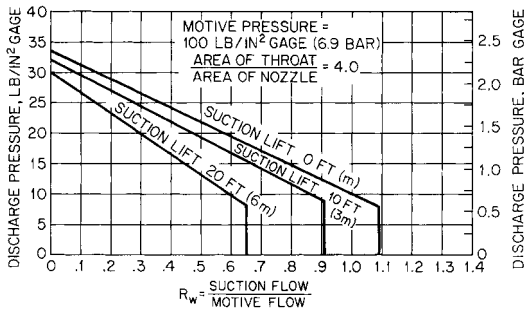


FIGURE 5 Characteristic performance of an eductor

**Performance Characteristics** Figure 5 illustrates the performance characteristics of eductors. Note the sharp break in flow rate below the design point. For this reason, all eductors are not designed for a peak efficiency. It is often advantageous to have a wide span of performance with lower efficiencies rather than a peak performance with very limited range. (See Section 4.1; where, also, the validity of assuming a straight-line head-vs.-suction flow characteristic is discussed.)

**Applications** Beside the obvious advantages of being self-priming, having no moving parts, and requiring no lubrication, eductors can be made from any machinable material in addition to special materials, such as stoneware, Teflon,<sup>®\*</sup> heat-resistant glass, and fiberglass. The applications throughout industry are too numerous to mention, but some of the more common will be discussed here. The type of eductor is determined by the service intended.

**GENERAL PURPOSE EDUCTORS** Table 1 is a capacity (flow rate) table for a general purpose eductor used for pumping and blending. This type of eductor, illustrated in Figure 6, has a broad performance span rather than a high peak efficiency point. Standard construction materials for this type of eductor are cast iron, bronze, stainless steel, and PVC. Typical uses include cesspool pumping, deep-well pumping, bilge pumping aboard ship, and condensate removal.

The following problem illustrates the use of Table 1.

**EXAMPLE 2** Pump 30 gpm (6.81 m<sup>3</sup>/h) of water from a sump 5 ft (0.61 m) below ground. Discharge to drain at atmospheric pressure. Motive water available is 40 lb/in<sup>2</sup> (2.8 bar) gage.

**Solution** Enter left side of Table 1 at 5 ft (1.5 m) suction lift and 0 lb/in<sup>2</sup> (bar) gage discharge pressure. Read horizontally across to 40 lb/in<sup>2</sup> (2.8 bar) gage operating water pressure. Read 9.6 gpm (2.18 m<sup>3</sup>/h) suction and 7.3 gpm (1.66 m<sup>3</sup>/h) operating fluid. These values are obtained in a 1-in (25.4-mm) eductor with a capacity ratio of 1.0.

To determine the capacity ratio of the required unit, divide the required suction by the quantity handled in 1-in (25.4-mm) eductor:

$$\text{in USCS units} \quad \text{Capacity ratio} = \frac{30}{9.6} = 3.13$$

$$\text{in SI units} \quad \text{Capacity ratio} = \frac{6.81}{2.18} = 3.13$$

\*Teflon is a registered trademark of E. I. DuPont de Nemours and Co., Inc.



**TABLE 1** Capacity (flow rate) table of standard 1-in (25.4-mm) water-jet eductors, gpm<sup>a</sup>

Suction lift, ft(m)	Discharge pressure, lb/in <sup>2</sup> (bar) gage	Function	Operating water pressure, lb/in <sup>2</sup> (bar) gage									
			10 (0.69)	20 (1.4)	30 (2.1)	40 (2.8)	50 (3.4)	60 (4.1)	80 (5.5)	100 (6.9)		
0 (0)	0 (0)	Suction	5.85	8.1	9.5	10.0	12.0	12.0	12.0	12.0	12.0	
		Operating	3.55	5.0	6.1	7.1	7.9	8.7	10.0	11.0	11.0	
	5 (0.34)	Suction	...	1.4	4.1	6.0	8.0	10.0	11.0	12.0	12.0	
		Operating	...	4.9	6.1	7.0	7.9	8.6	10.0	11.0	11.0	
	10 (0.69)	Suction	...	...	0.28	2.3	4.8	6.4	8.8	11.0	11.0	
		Operating	...	...	5.9	6.8	7.8	8.5	9.8	11.0	11.0	
	15 (1.0)	Suction	...	...	...	...	1.2	3.4	5.9	8.6	8.6	
		Operating	...	...	...	...	7.7	8.4	9.8	11.0	11.0	
	20 (1.4)	Suction	...	...	...	...	...	0.3	3.5	5.9	5.9	
		Operating	...	...	...	...	...	8.2	9.7	11.0	11.0	
	25 (1.7)	Suction	...	...	...	...	...	...	0.83	3.9	3.9	
		Operating	...	...	...	...	...	...	9.6	11.0	11.0	
	30 (2.1)	Suction	...	...	...	...	...	...	...	1.7	1.7	
		Operating	...	...	...	...	...	...	...	11.0	11.0	
5 (1.5)	0 (0)	Suction	4.4	6.8	8.6	9.6	11.0	11.0	12.0	12.0	12.0	
		Operating	3.9	5.3	6.4	7.3	8.1	8.8	10.0	11.0	11.0	
	5 (0.34)	Suction	...	1.5	3.2	5.0	7.0	9.0	11.0	11.0	11.0	
		Operating	...	5.2	6.3	7.2	8.0	8.7	10.0	11.0	11.0	
	10 (0.69)	Suction	...	...	...	1.9	3.6	5.6	8.6	10.0	10.0	
		Operating	...	...	...	7.1	7.9	8.6	10.0	11.0	11.0	
	15 (1.0)	Suction	...	...	...	...	1.1	2.6	5.8	8.3	8.3	
		Operating	...	...	...	...	7.8	8.6	9.9	11.0	11.0	
	20 (1.4)	Suction	...	...	...	...	...	...	3.3	5.6	5.6	
		Operating	...	...	...	...	...	...	9.8	11.0	11.0	
	25 (1.7)	Suction	...	...	...	...	...	...	0.47	3.6	3.6	
		Operating	...	...	...	...	...	...	9.8	11.0	11.0	
	30 (2.1)	Suction	...	...	...	...	...	...	...	1.5	1.5	
		Operating	...	...	...	...	...	...	...	11.0	11.0	
10 (3.0)	0 (0)	Suction	2.0	4.6	6.7	8.3	9.0	10.0	10.0	10.0	10.0	
		Operating	4.2	5.5	6.6	7.4	8.2	9.0	10.0	11.0	11.0	
	5 (0.34)	Suction	...	...	2.0	4.3	5.9	7.7	9.9	10.0	10.0	
		Operating	...	...	6.5	7.4	8.2	8.9	10.0	11.0	11.0	
	10 (0.69)	Suction	...	...	...	1.1	3.0	4.5	8.1	9.6	9.6	
		Operating	...	...	...	7.3	8.1	8.8	10.0	11.0	11.0	
	15 (1.0)	Suction	...	...	...	...	1.1	2.1	5.6	7.3	7.3	
		Operating	...	...	...	...	8.0	8.7	10.0	11.0	11.0	
	20 (1.4)	Suction	...	...	...	...	...	...	2.8	5.3	5.3	
		Operating	...	...	...	...	...	...	9.9	11.0	11.0	
	25 (1.7)	Suction	...	...	...	...	...	...	...	2.8	2.8	
		Operating	...	...	...	...	...	...	...	11.0	11.0	
	30 (2.1)	Suction	...	...	...	...	...	...	...	1.1	1.1	
		Operating	...	...	...	...	...	...	...	11.0	11.0	
15 (4.6)	0 (0)	Suction	...	3.3	5.3	7.9	8.4	8.9	8.9	9.1	9.1	
		Operating	...	5.7	6.8	7.6	8.4	9.1	10.0	12.0	12.0	
	5 (0.34)	Suction	...	...	...	4.0	4.9	7.3	8.6	9.1	9.1	
		Operating	...	...	...	7.6	8.3	9.0	10.0	11.0	11.0	
	10 (0.69)	Suction	...	...	...	...	2.4	4.0	6.4	8.6	8.6	
		Operating	...	...	...	...	8.2	9.0	10.0	11.0	11.0	
	15 (4.6)	15 (1.0)	Suction	...	...	...	...	...	...	4.2	6.8	6.8

TABLE 1 Continued.

Suction lift, ft(m)	Discharge pressure, lb/in <sup>2</sup> (bar) gage	Function	Operating water pressure, lb/in <sup>2</sup> (bar) gage								
			10 (0.69)	20 (1.4)	30 (2.1)	40 (2.8)	50 (3.4)	60 (4.1)	80 (5.5)	100 (6.9)	
20 (6.1)	20 (1.4)	Operating	...	...	...	...	...	...	10.0	11.0	
		Suction	...	...	...	...	...	...	2.1	4.5	
	25 (1.7)	Operating	...	...	...	...	...	...	10.0	11.0	
		Suction	...	...	...	...	...	...	...	1.9	
	20 (6.1)	0 (0)	Suction	...	2.0	4.0	6.4	7.8	7.8	7.8	7.8
			Operating	...	6.0	7.0	7.8	8.6	9.3	11.0	12.0
		5 (0.34)	Suction	...	...	...	2.8	3.9	6.3	7.8	7.8
			Operating	...	...	...	7.7	8.5	9.2	10.0	12.0
		10 (0.69)	Suction	...	...	...	...	1.2	3.1	5.7	7.1
			Operating	...	...	...	...	8.3	9.1	10.0	12.0
		15 (1.0)	Suction	...	...	...	...	...	...	3.6	5.4
			Operating	...	...	...	...	...	...	10.0	11.0
20 (1.4)		Suction	...	...	...	...	...	...	1.4	3.8	
		Operating	...	...	...	...	...	...	10.0	11.0	
25 (1.7)		Suction	...	...	...	...	...	...	...	1.5	
		Operating	...	...	...	...	...	...	...	11.0	
Relative capacities of standard sizes											
Size eductor, in (mm)	$\frac{1}{2}$ (12.7)	$\frac{3}{4}$ (19.1)	1 (25.4)	$1\frac{1}{2}$ (38.1)	2 (50.8)	$2\frac{1}{2}$ (63.5)	3 (76.2)	4 (102)	6 (152)		
Capacity ratio	0.36	0.64	1.00	2.89	4.00	6.25	9.00	16.00	36.00		

<sup>a</sup>gpm  $\times$  0.227 = m<sup>3</sup>/h.

Source: Schutte and Koerting.

Referring to the bottom of Table 1, a 2-in (50.8-mm) eductor with a capacity ratio of 4.0 is obtained. The required motive flow is then

in USCS units  $4(7.3) = 29.2$  gpm

in SI units  $4(1.66) = 6.64$  m<sup>3</sup>/h

and the suction capacity is

in USCS units  $4(9.6) = 38.4$  gpm

in SI units  $4(2.18) = 8.72$  m<sup>3</sup>/h

A  $1\frac{1}{2}$ -in (38-mm) unit can handle 2.89 times the values in Table 1, or 27.7 gpm (6.3 m<sup>3</sup>/h) suction when using 21 gpm (4.8 m<sup>3</sup>/h) motive water at 40 lb/in<sup>2</sup> (2.8 bar) gage. If suction flow rate is not critical, some capacity can be sacrificed in order to use a smaller and therefore lower-cost eductor. If optimum performance is desired, it is necessary to size a special eductor using Figures 3 and 4.

Figure 7 illustrates more streamlined versions for higher suction lifts or applications involving the handling of slurries. This type of eductor is often used to remove condensate from vessels under vacuum. The advantage is that eductors require only 2 ft (0.61 m) *NPSH* and, being smaller than mechanical pumps, save considerable space. Further, a partial vapor load is much less likely to vapor-lock a jet pump because the venturi tube

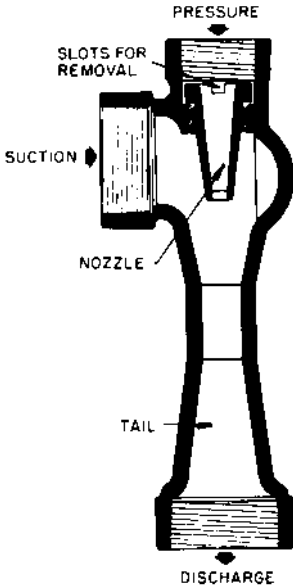


FIGURE 6 General purpose eductor (Schutte and Koerting)

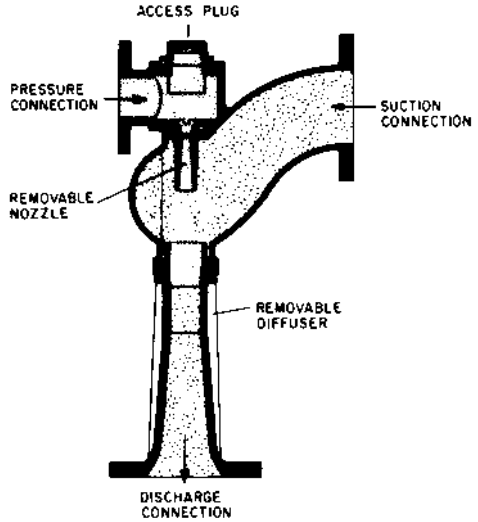


FIGURE 7 Streamlined eductor (Schutte and Koerting)

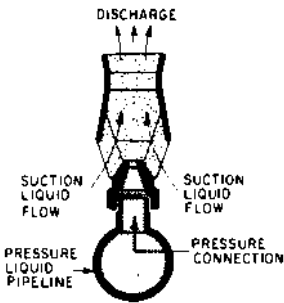


FIGURE 8 Sparger nozzle (Schutte and Koerting)

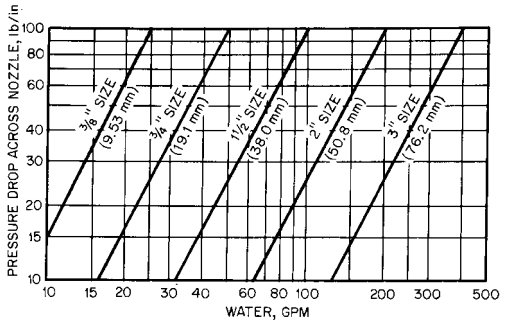


FIGURE 9 Motive flow rate of Sparger nozzles (gpm  $\times$  0.227 = m<sup>3</sup>/h; lb/in<sup>2</sup>  $\times$  0.0689 = bar) (Schutte and Koerting)

minimizes the expansion effect of flashing vapor. Sizing is done in the manner illustrated in Example 1, using Figures 3 and 4.

**MIXING EDUCTORS** Although any eductor is inherently a mixing device, some are specifically designed as mixers. They are used to replace mechanical agitators and are located inside the tank containing the fluid to be agitated. Figure 8 illustrates the simplest type of eductor, the *Sparger nozzle*. These units entrain a volume of suction fluid that is approximately three times the volume of motive fluid. A 20-lb/in<sup>2</sup> (1.4-bar) drop across the nozzle is recommended for proper mixing. Figure 9 shows the motive flow rates for this type

**TABLE 2** Motive flow rates of tank mixing eductors, gpm<sup>a</sup>

Pressure difference, inlet to tank, lb/in <sup>2</sup> (bar) gage								
Size, in (mm)	10 (0.69)	20 (1.4)	30 (2.1)	40 (2.8)	50 (3.4)	60 (4.1)	80 (5.5)	100 (6.9)
$\frac{1}{2}$ (12.7)	3.5	5.0	6.0	7.0	8.0	8.5	10.0	11.0
$\frac{3}{4}$ (19.1)	10.0	14.5	17.5	20.0	23.0	24.5	29.0	32.0
1 (25.4)	14.2	20.0	25.0	28.0	30.0	34.5	40.0	44.5
$1\frac{1}{4}$ (31.8)	22.0	31.0	37.5	44.0	50.0	53.0	62.5	69.0
$1\frac{1}{2}$ (38.1)	31.5	45.0	54.0	63.0	72.0	76.5	90.0	99.0
2 (50.8)	56.0	80.0	96.0	112.0	128.0	136.0	160.0	176.0
3 (76.2)	126.0	180.0	216.0	252.0	288.0	306.0	360.0	396.0
4 (102)	224.0	320.0	384.0	448.0	512.0	544.0	640.0	704.0
5 (127)	350.0	500.0	600.0	700.0	800.0	850.0	1000.0	1100.0
6 (152)	494.0	720.0	864.0	1008.0	1152.0	1224.0	1440.0	1584.0

<sup>a</sup>gpm  $\times$  0.227 = m<sup>3</sup>/h

Source: Schutte and Koerting.

of eductor. Sparger nozzles are normally used for shallow tanks, whereas the following tank mixer described is preferred for deeper vessels.

Figure 10 illustrates a type of eductor called a *tank mixer*. It is installed under the tank containing the fluid to be agitated. Motive capacities are shown in Table 2. The units are usually custom-designed for a specific entrainment ratio, the required capacity being determined by the quantity of tank fluid, the ratio of mixture desired, and the depth of the tank being agitated.

**EXAMPLE 3** It is desired to blend recycled tank fluid into a tank 20 ft (6.1 m) deep in a volume ratio of 1 motive to 1.5 suction. The tank contains 7500 gal (28.4 m<sup>3</sup>), and it is desired to turn over the tank in 30 min. The motive pump will deliver 60 lb/in<sup>2</sup> (4.14 bar) gage at the eductor nozzle. What size mixing eductor is needed?

**Solution** The 500 gal (28.4 m<sup>3</sup>) turned over in 30 minutes is equivalent to 250 gpm (56.8 m<sup>3</sup>/h). Because the motive fluid in this case is recycled from the tank, both motive and suction fluid contribute to the tank turnover. In the ratio of 1.5 suction to 1 motive fluid, the motive quantity required to attain a circulation rate of 250 gpm (56.8 m<sup>3</sup>/h) is 100 gpm (22.7 m<sup>3</sup>/h). To select the size, it is necessary to obtain the differential pressure across the nozzle orifice of the eductor. Because the eductor is below the tank, the net driving head is 60 lb/in<sup>2</sup> gage - 20/2.31 = 51.35 lb/in<sup>2</sup> (4.14 - 6.1/10.2 = 3.54 bar) gage across the nozzle. Enter Table 2 and interpolate between 50 and 60 lb/in<sup>2</sup> (3.4 and 4.1 bar) gage. A  $1\frac{1}{2}$ -in (38-mm) eductor will pass only 73 gpm (16.6 m<sup>3</sup>/h), whereas a 2-in (51-mm) eductor will pass 129 gpm (29.3 m<sup>3</sup>/h). The selection would then be a 2-in (51-mm) mixing eductor.

**SPINDLE PROPORTIONING EDUCTORS** Another type of mixing eductor is illustrated in Figure 11. Typical applications of this type include mixing hydrocarbons with caustic, oxygen, or copper chloride slurries; producing emulsions; and proportioning liquids in chemical process industries. In critical applications, the regulating spindle is sometimes fitted with a diaphragm operator to achieve close control. Table 3 shows operating pressures and flow rates on several typical applications for units of this type.

**SAND AND MUD EDUCTORS** Figure 12 illustrates a sand and mud eductor used for pumping out wells, pits, tanks, sumps, and similar containers where there is an accumulation of

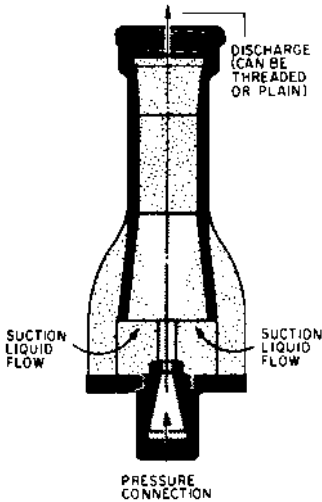


FIGURE 10 Tank mixing eductor (Schutte and Koerting)

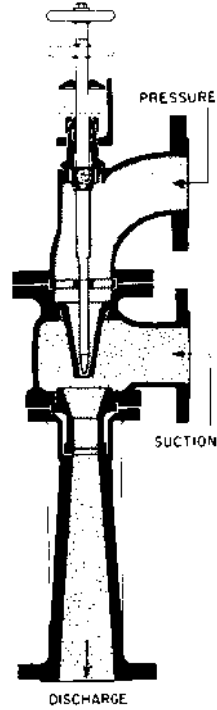


FIGURE 11 Proportioning eductor (Schutte and Koerting)

TABLE 3 Operating pressures and flow rates—proportioning eductor

Motive liquid/ suction fluid	Naphtha/ copper chloride slurry	Hydrocarbon/ hydrocarbon	Gasoline/ slurry	Gasoline/ water	Sour kerosene/ kerosene slurry
Pressure, lb/in <sup>2</sup> (bar)					
gauge					
Motive	165 (11.4)	295 (20.3)	170 (11.7)	75 (5.2)	146 (10.1)
Suction	40 (2.8)	5 (0.3)	75 (5.2)	50 (3.4)	60 (4.1)
Discharge	75 (5.2)	10 (0.7)	100 (6.9)	50 (3.4)	70 (4.8)
Flow, gpm (m <sup>3</sup> /h)					
Motive	30 (6.8)	10 (2.3)	90 (20.4)	170 (38.6)	482 (109.5)
Suction	20 (4.5)	58 (13.2)	74 (16.8)	42 (9.5)	700 (159.0)
Discharge	50 (11.4)	68 (15.4)	164 (37.2)	212 (48.1)	1182 (268.5)
Eductor size, in (mm)	1½ (38.1)	3 (76.2)	4 (102)	4 (102)	6 (152)

Source: Schutte & Koerting.

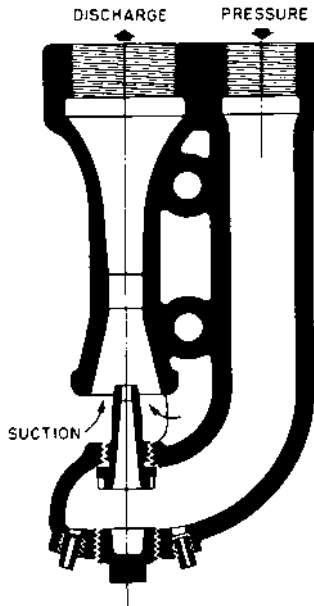


FIGURE 12 Sand and mud eductor (Schutte and Koerting)

TABLE 4 Relative capacities (flow rates) of sand and mud eductors

Capacity of standard 3-in (76.2-mm) eductor						
Operating water pressure, lb/in <sup>2</sup> (bar) gage	40.0 (2.8)	50.0 (3.4)	60.0 (4.1)			
Total motive fluid, gpm (m <sup>3</sup> /h)	69.5 (15.8)	77.5 (17.6)	85.0 (19.3)			
Net suction fluid, gpm (m <sup>3</sup> /h)	30.0 (6.8)	34.5 (7.8)	38.5 (8.7)			
Maximum discharge head, ft (m)	22.0 (6.7)	26.0 (7.9)	32.0 (9.8)			
Relative capacities of standard sizes						
Size eductor, in (mm)	1½ (38.1)	2½ (63.5)	3 (76.2)	4 (102)	5 (127)	6 (152)
Capacity ratio	0.29	0.62	1.00	1.85	2.80	3.80

Source: Schutte and Koerting.

sand, mud, slime, or other material not easily handled by other eductors. With this type of eductor, the bottom of the pressure chamber is fitted with a ring of agitating nozzles that stirs the material in which the jet is submerged to allow maximum entrainment. Relative capacities for this type of eductor are shown in Table 4, which is used in the same manner as Table 1. The required suction flow is divided by the suction capacity selected from Table 4 under the appropriate motive pressure. This value is the capacity ratio. From the table, select the eductor by choosing the next highest capacity ratio. Actual flow rates are then determined by multiplying the values in the table by the capacity ratio of the eductor selected. Maximum discharge head is read from the table.

**SOLIDS-HANDLING EDUCTORS** Figure 13 illustrates a specific type of eductor called a *hopper eductor*, made for handling slurries or dry solids in granular form and used for eject-

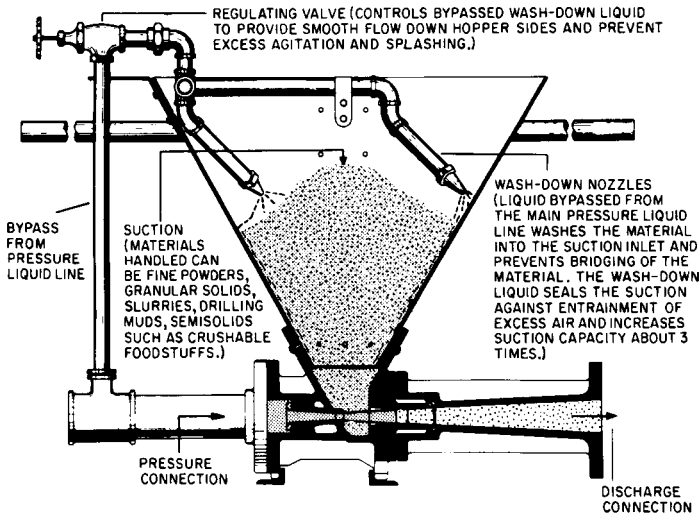


FIGURE 13 Hopper eductor (Schutte and Koerting)

TABLE 5 Relative capacities (flow rates) of hopper eductors

Capacity of standard 1½-in (38-mm) eductor					
Operating water pressure, lb/in <sup>2</sup> (bar) gage	30 (2.1)	40 (2.8)	50 (3.4)	60 (4.1)	
Suction capacity, ft <sup>3</sup> /h (m <sup>3</sup> /h)	13 (0.37)	36 (1.0)	72 (2.0)	90 (2.5)	
Maximum discharge pressure, lb/in <sup>2</sup> (bar) gage	14 (1.0)	17 (1.1)	18 (1.2)	20 (1.4)	
Motive water consumption, gpm (m <sup>3</sup> /h) <sup>a</sup>	35 (7.9)	40 (9.1)	45 (10.2)	50 (11.4)	
Relative capacities of standard sizes					
Size, in (mm)	1½ (38.1)	2 (50.8)	3 (76.2)	4 (102)	6 (152)
Capacity ratio	1.00	1.60	3.50	6.00	18.00

<sup>a</sup>Based on using approximately 10% motive water through washdown nozzles.

Source: Schutte and Koerting

ing sludges from tank bottoms, pumping sand from filter beds, and washing or conveying granular materials. Typical construction is cast iron with hardened steel nozzle and throat bushings. In operation, the washdown nozzles are adjusted to provide smooth flow down the hopper sides, thus preventing bridging of the material being handled and also sealing the eductor suction against excess quantities of air. Without this seal, the capacities shown in Table 5 should be divided by approximately 3. Table 6 shows typical materials handled by this eductor and their bulk density. Use of the capacity table for hopper eductors is similar to use of Tables 1 and 4, except the suction quantities required are expressed in cubic feet (cubic meters). Capacity ratio is determined by dividing the value in the table into the required suction flow, and the next largest size eductor is selected.

Another type of solids-handling eductor is illustrated in Figure 14. This *annular-orifice eductor* is used where the material being handled tends to agglomerate and gum up when wetted and has been used successfully for handling and mixing hard-to-wet solids. In this

**TABLE 6** Typical materials handled by hopper eductors

Material	Approx. bulk density, lb/ft <sup>3</sup> (kg/m <sup>3</sup> )
Borax	50–55 (800–880)
Charcoal	18–28 (290–450)
Diatomaceous earth	10–20 (160–320)
Lime, pebble	56 (900)
Lime, powdered	32–40 (510–640)
Fly ash	35–40 (560–640)
Mash	60–65 (960–1040)
Rosin	67 (1070)
Salt, granulated	45–51 (720–820)
Salt, rock	70–80 (1120–1280)
Sand, damp	75–85 (1200–1360)
Sand, dry	90–100 (1440–1600)
Sawdust, dry	13 (210)
Soda ash, light	20–35 (320–560)
Sodium nitrate, dry	80 (1280)
Sulfur, powdered	50–60 (800–960)
Wheat	48 (770)
Zinc oxide, powdered, dry	10–35 (160–560)

Source: Schutte and Koerting.

unit, intimate mixing occurs in the throat, and the device is virtually clogproof. Normally this unit is installed directly over the tank into which the mixture is discharged. Table 7 shows capacities for this type of unit.

Capacity Table 7 is similar to Table 5, and the selection method is the same as discussed previously.

**MULTINOZZLE EDUCTORS** Figure 15 illustrates an annular multinozzle eductor designed for special applications where the suction fluid contains solids or semisolids. It is used primarily for large flows at low discharge heads. Because these units have relatively large air-handling capacities, they are well suited for priming large pumps, such as dredging pumps, where air pockets can cause these pumps to lose their prime. These eductors are designed by using the basic equations for head ratio. The appropriate efficiency factor is selected from Figure 2, and the volumetric flow ratio is calculated. Figure 4 is used to size the eductor after discharge flow has been determined.

**DEEP-WELL EDUCTORS** The eductor illustrated in Figure 16 is typical of those used in conjunction with a mechanical pump for commercial and residential water supply from a deep well. The eductor is used to lift water from a level below barometric height up to a level where the suction of the motive pump at the surface can lift the water the remaining distance.

In operation, the eductor is fitted with hoses connected to the suction and discharge of the motive pump and dropped into the well casing. An initial prime is required, which is maintained by the foot valve at the suction of the eductor. When the surface pump is activated, pressure water through the eductor entrains water from the well, lifting it high enough to enable the mechanical pump to carry it to the surface. A bypass valve at the surface diverts the suction quantity to a receiving tank.

Capacities of these units depend on the depth of the well and the centrifugal pump. The standard commercial unit has 1-in (25-mm) pressure and 1¼-in (32-mm) discharge connections and is available with a variety of nozzle and diffuser combinations for use with standard centrifugal pumps at varying depths. The following example illustrates how to calculate this type of unit.



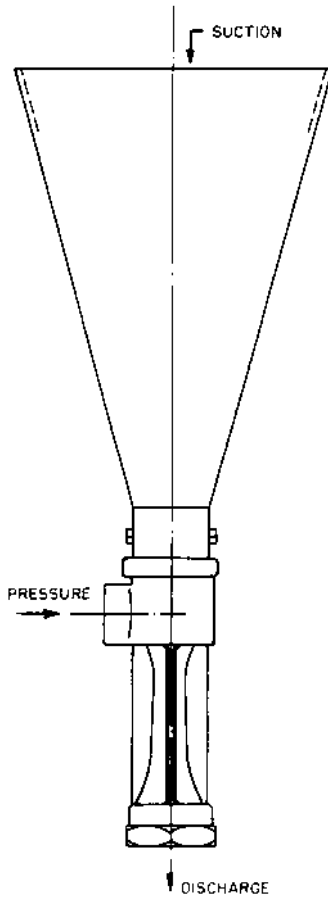


FIGURE 14 Annual eductor (Schutte and Koerting)

**EXAMPLE 4** A centrifugal pump with a capacity of 100 gpm (22.7 m<sup>3</sup>/h) at a total discharge head of 150 ft (45.7 m) and requiring 10 ft (3.05 m) NPSH is available to operate an eductor to pump water at 50 ft (15.2 m) below grade. Find the quantity of water that can be delivered at 60 lb/in<sup>2</sup> (4.1 bar) gage (see Figure 17).

**Solution** The available operating head is 138.6 ft + 50 ft - frictional loss (42.2 + 15.2 - frictional loss). As a first assumption, the frictional loss is ignored and the head ratio is 188.6/40.83 = 4.62 (57.4/12.38 = 4.62). From Figure 2 at NPSH 33.6 ft (10.24 m),  $\epsilon = 0.9$  and

$$R_w = R_q = 0.9\sqrt{4.62} - 1 = 0.934$$

(from Eqs. 5 and 6)

With  $Q_R$  fixed at 100 gpm (22.7 m<sup>3</sup>/h),

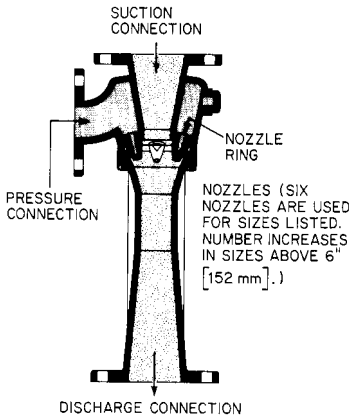
**TABLE 7** Relative capacities (flow rates) of annual eductors

Capacity of standard 1½-in (38.1-mm) mixing eductor, 5 lb/in <sup>2</sup> (0.34 bar) gage discharge pressure						
Motive pressure, lb/in <sup>2</sup> (bar) gage	30 (2.1)	40 (2.8)	60 (4.1)	80 (5.5)	100 (6.9)	
Entrainment, ft <sup>3</sup> /h (m <sup>3</sup> /h)	2.6 (0.07)	7.1 (0.20)	17.9 (0.51)	22.0 (0.62)	23.8 (0.67)	
Motive flow, gpm (m <sup>3</sup> /h)	12.7 (2.88)	14.6 (3.31)	17.9 (4.06)	20.7 (4.70)	23.1 (5.24)	

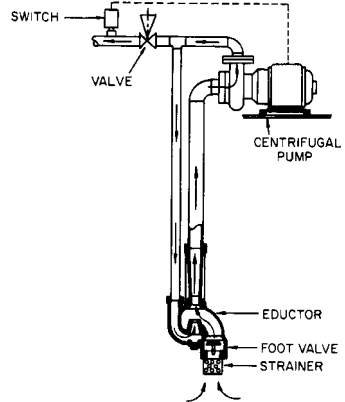
  

Relative capacities of standard sizes						
Size, in (mm)	1¼ (31.8)	1½ (38.1)	2 (50.8)	2½ (63.5)	3 (76.2)	4 (102)
Capacity ratio	0.62	1.00	1.43	2.86	4.76	8.80

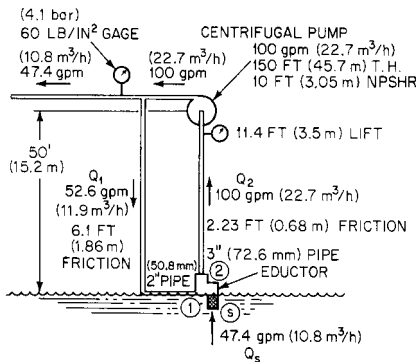
Source: Schutte and Koerting.



**FIGURE 15** Multinozzle eductor (Schutte and Koerting)



**FIGURE 16** Centrifugal-jet pump combination



**FIGURE 17** Centrifugal-jet pump for Example 4

$$\text{in USCS units} \quad Q_1 = \frac{100}{1 + R_q} = \frac{100}{1.934} = 51.7 \text{ gpm}$$

$$\text{in SI units} \quad Q_1 = \frac{22.7}{1.934} = 11.7 \text{ m}^3/\text{h}$$

The motive line size is now chosen by selecting a reasonable velocity and frictional loss. Choosing a 2-in (51-mm) pipe size, velocity is 5.57 ft/s (1.70 m/s) and frictional loss is 6.1 ftH<sub>2</sub>O (1.86 mH<sub>2</sub>O). The revised operating head becomes 188.6 – 6.1 = 182.5 ft (57.4 – 1.86 = 55.6 m) and

$$\text{in USCS units} \quad R_q = 0.9\sqrt{182.5/40.83} - 1 = 0.9$$

$$\text{in SI units} \quad R_q = 0.9\sqrt{55.6/12.38} - 1 = 0.9$$

then  $Q_1 = 100/1.9 = 52.6 \text{ gpm}$  ( $22.7/1.9 = 11.9 \text{ m}^3/\text{h}$ ). (This value is close enough so that a third trial is not necessary.) The suction flow that can be delivered is then

$$\text{in USCS units} \quad 100 - 52.6 = 47.4 \text{ gpm}$$

$$\text{in SI units} \quad 22.7 - 11.9 = 10.8 \text{ m}^3/\text{h}$$

**PRIMING EDUCTORS—WATER-JET EXHAUSTERS** Eductors are often used as priming devices for mechanical pumps. In this application, the eductor is used to remove air rather than water. Liquid jets are not well suited for pumping noncondensables; therefore, the capacities are low. However, the volume being primed is usually small, and so the low capacity is not a factor. When larger volumes are involved, such as condenser water boxes, it is more feasible to use an exhauster. The water-jet eductor of Figure 6 is converted to a water-jet exhauster by replacing the jet nozzle with a solid-cone spray nozzle. Evacuating rates and capacity tables for such a unit are shown in Figure 18 and Table 8. Eductors have approximately one-fifth the air-handling capacities of water-jet exhausters when supplied with similar motive quantities and pressures.

**EXAMPLE 5** From Figure 18 and Table 8, determine size and water consumption to exhaust 15 standard ft<sup>3</sup>/min (0.42 m<sup>3</sup>/min) of air at 20 inHg (508 mmHg) abs discharging to atmosphere using 60 lb/in<sup>2</sup> (4.14 bar) gage motive water at 80°F (27°C).

**Solution** Enter Figure 18 at 80°F (27°C) (1); read horizontally to the suction pressure 20 inHg (508 mmHg) abs (2); project vertical line to 60 lb/in<sup>2</sup> (4.14 bar) gage motive pressure (3); project a horizontal line for the capacity of a 1-in (25-mm) exhauster (4); divide desired flow by the capacity of a 1-in (25-mm) unit, which is 1.9 standard ft<sup>3</sup>/min, (0.054 m<sup>3</sup>/min), to find capacity ratio:  $15/1.9 = 7.9$  ( $0.42/0.054 = 7.9$ ).

The capacity ratio table shows that a 3-in (76-mm) exhauster with a capacity ratio of 9.0 is required. The motive water quantity from Table 8 is 86 gpm (19.5 m<sup>3</sup>/h). *Note:* Table 8 gives water consumption at 15 inHg (381 mmHg) abs; because flow varies as the square of pressure differential across the nozzle, the exact flow is obtained as follows:

Nozzle upstream pressure:

$$\text{in USGS units} \quad 60 + 14.7 = 74.7 \text{ lb/in}^2 \text{ abs}$$

$$\text{in SI units} \quad 4.14 + 1.01 = 5.15 \text{ bar abs}$$

Nozzle downstream pressure:

$$\text{in USCS units} \quad 20 \text{ inHg abs} \left( \frac{14.7 \text{ lb/in}^2}{30 \text{ inHg}} \right) = 9.8 \text{ lb/in}^2 \text{ abs}$$

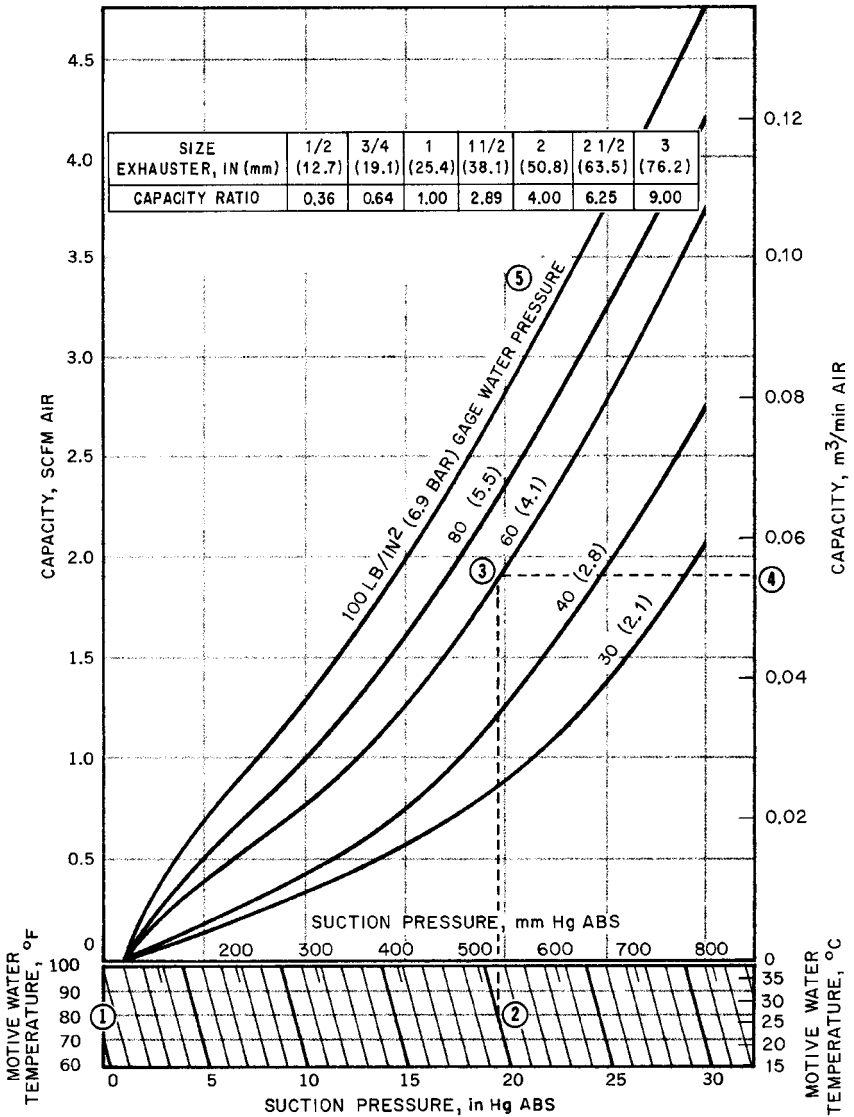


FIGURE 18 Capacity curve of water-jet exhausters (Schutte and Koerting)

in SI units  $508 \text{ mmHg abs} \left( \frac{1.01 \text{ bar}}{762 \text{ mmHg}} \right) = 0.67 \text{ bar abs}$

Operating differential:

in USCS units  $74.7 - 9.8 = 64.9 \text{ lb/in}^2$

in SI units  $5.15 - 0.67 = 4.48 \text{ bar}$

**TABLE 8** Approximate water consumption of water-jet exhausters, gpm<sup>a, b</sup>

Water pressure, lb/in <sup>2</sup> (bar) gage					
Size, in (mm)	30 (2.1)	40 (2.8)	60 (4.1)	80 (5.5)	100 (6.9)
$\frac{1}{2}$ (12.7)	2.6	2.9	3.4	3.8	4.2
$\frac{3}{4}$ (19.1)	4.6	5.3	6.4	7.4	8.3
1 (25.4)	6.2	6.8	8.1	9	10
$1\frac{1}{2}$ (38.1)	20	23	27	30	32
2 (50.8)	28	31	36	41	45
$2\frac{1}{2}$ (63.5)	46	51	60	67	73
3 (76.2)	66	73	86	96	106

<sup>a</sup>gpm  $\times$  0.227 = m<sup>3</sup>/h

<sup>b</sup>All flows at 15 in (381 mm) Hg abs.

Source: Schutte and Koerting.

Table differential:

$$\text{in USCS units} \quad 74.7 - 15 \left( \frac{14.7}{30} \right) = 67.35 \text{ lb/in}^2$$

$$\text{in SI units} \quad 5.15 - 381 \left( \frac{1.01}{762} \right) = 4.64 \text{ bar}$$

Actual flow:

$$\text{in USCS units} \quad 86 \left( \frac{64.9}{67.35} \right)^{1/2} = 84.4 \text{ gpm}$$

$$\text{in SI units} \quad 19.5 \left( \frac{4.48}{4.64} \right)^{1/2} = 19.2 \text{ m}^3/\text{h}$$

## SIPHONS

**Operation** As previously defined, the term *siphon* refers to a jet pump utilizing a condensable vapor to entrain a liquid and discharge to a pressure intermediate between motive and suction pressure. The principal motive fluid is steam.

In an eductor, the high-pressure motive fluid enters through a nozzle and creates a vacuum by jet action, which causes suction fluid to enter the mixing chamber. The siphon of Figure 19 is identical to the eductor of Figure 6 except that, unlike the eductor, the siphon motive nozzle is a converging-diverging nozzle to achieve maximum velocity at the nozzle tip. The velocity is supersonic at this point. The motive fluid is condensed into the suction fluid on contact and imparts its energy to the liquid, thus impelling it through the diffuser. The diffuser section is the same as an eductor diffuser, and it converts the velocity energy to pressure at the discharge. To achieve maximum performance, the siphon nozzle must be expanded to the desired suction pressure in order to achieve the highest possible velocity. Because negligible radiation losses are encountered, the siphon is 100% thermally efficient in that the heat in the incoming water plus the heat in the operating steam must equal the heat of the mixture plus its mechanical energy. Furthermore, the momentum of the incoming water plus the momentum of the expanded steam is equal to the momentum of the discharge mixture less impact and frictional losses.

It is important that the motive steam be condensed in the suction liquid prior to the throat for proper operation. If condensation does not occur, full available energy is not transferred. Furthermore, energy must be expended to recompress the uncondensed

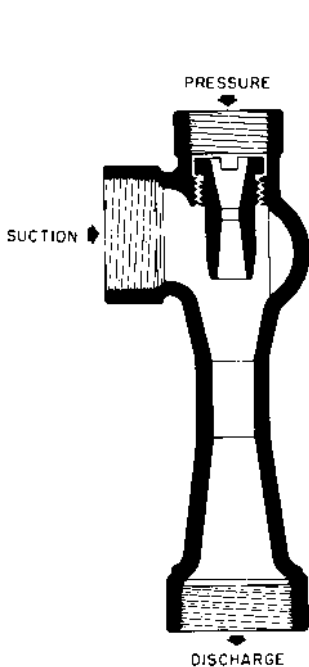


FIGURE 19 Standard siphon (Schutte and Koerting)

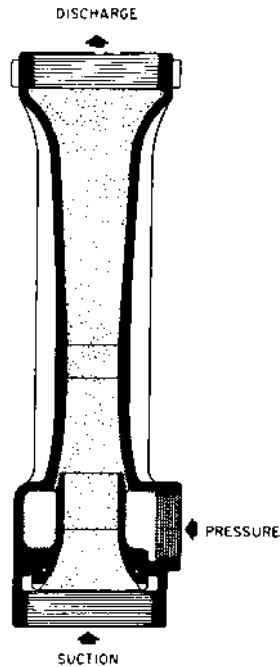


FIGURE 20 Annular siphon (Schutte and Koerting)

steam. For this reason, discharge temperature cannot exceed the boiling point at the discharge pressure. The fact that energy is required to recompress any uncondensed steam explains why air is a very poor motive fluid for liquid pumping.

**STANDARD SIPHONS** Tables 9 and 10 illustrate the capacity and operating characteristics of standard siphons. These tables are similar to the eductor capacity tables. To size a unit, read the suction capacity of a 1½-in (38-mm) unit from Table 9 at the appropriate motive steam pressure, suction lift, and discharge head. Divide the desired suction flow by this capacity to find the capacity ratio. From Table 10, find the unit with the next largest capacity ratio. Read the motive steam required under the proper motive pressure.

Standard materials of construction are cast iron, bronze, stainless, steel, and Pyrex®. If desired, special capacity ratios can be achieved by using a custom-designed unit. Sizes over 6 in (152 mm) can be fabricated of any suitable material.

**ANNULAR SIPHONS** Figure 20 illustrates an annular siphon. This unit is identical to the eductor of Figure 14 except that steam is the motive fluid. Capacity Table 11 is used in the same manner as previous examples. This type of siphon is used when inline flow is desired or when the suction liquid contains some solids. Units are available in cast iron through an 8-in (203-mm) size. Special materials or fabricated designs are also available.

### OTHER JET PUMP DEVICES

**Air Siphons** As previously mentioned, air is a very poor motive fluid for entraining a liquid because energy must be expended in compressing the air back to the discharge pressure. There are, however, applications where it is necessary to sample a liquid with no dilution.

**TABLE 9** Relative capacities of steam-jet siphons, gpm<sup>a</sup>

Suction lift, ft (m)	Suction temp., °F <sup>b</sup>	Operating steam pressure, lb/in <sup>2</sup> (bar) gage								Operating steam pressure, lb/in <sup>2</sup> (bar) gage							
		40 (2.8)	50 (3.4)	60 (4.1)	80 (5.5)	100 (6.9)	120 (8.3)	160 (11)	240 (16)	40 (2.8)	50 (3.4)	60 (4.1)	80 (5.5)	100 (6.9)	120 (8.3)	160 (11)	240 (16)
		0-ft (m) discharge head								20-ft (6.1-m) discharge head							
1 (0.3)	70	52	51	51	49	46	43	37	30	36	47	48	48	45	41	35	29
	90	45	44	43	42	40	37	33	26	37	44	43	43	41	38	33	26
	110	40	38	36	36	35	33	28	22	38	39	37	37	36	34	30	23
	130	35	32	30	30	29	29	25	...	35	33	31	31	30	29	25	...
	150	26	25	24	24	24	24	21	...	26	25	24	24	23	22	20	...
	165	17	17	17	18	18	17	17	...	17	17	17	17	17	17	16	...
4.45 10 (3.0)	70	38	38	37	35	30	28	25	20	27	36	37	35	31	29	25	19
	90	34	34	33	30	27	25	21	17	26	32	32	29	26	23	20	17
	110	28	27	26	25	23	21	18	...	26	27	27	25	23	21	18	...
	130	21	21	21	20	18	16	14	...	21	22	22	21	18	16	14	...
	145	16	16	16	16	14	12	...	...	16	16	16	16	14	12	...	...
15 (4.6)	70	34	32	30	26	23	21	18	14	24	33	32	27	24	23	19	15
	90	29	28	26	23	20	18	16	12	23	28	27	23	20	19	16	12
	110	24	23	22	19	17	15	13	...	23	23	22	19	17	15	13	...
	130	17	17	17	15	13	11	...	...	17	17	17	14	13	...	...	...
	145	10	12	11	9	...	...	...	...	11	11	10	10	...	...	...	...
20 (6.1)	70	26	23	21	18	16	15	13	...	24	24	22	19	17	15	12	...
	90	22	19	17	15	14	12	11	...	19	20	18	15	14	12	11	...
	110	18	16	14	12	11	10	...	...	17	16	14	12	11	...	...	...
	125	13	12	11	...	...	...	...	...	12	11	10	...	...	...	...	...

**TABLE 9** Continued.

Suction lift, ft (m)	Suction temp., °F <sup>b</sup>	Operating steam pressure, lb/in <sup>2</sup> (bar) gage								Operating steam pressure, lb/in <sup>2</sup> (bar) gage							
		40 (2.8)	50 (3.4)	60 (4.1)	80 (5.5)	100 (6.9)	120 (8.3)	160 (11)	240 (16)	40 (2.8)	50 (3.4)	60 (4.1)	80 (5.5)	100 (6.9)	120 (8.3)	160 (11)	240 (16)
1 (0.3)		40-ft (12.2-m) discharge head								50-ft (15.2-m) discharge head							
	70	...	20	33	47	44	41	36	29	...	...	18	44	44	41	36	28
	90	...	18	36	43	42	39	34	27	...	...	21	42	42	39	34	27
	110	...	20	36	37	37	35	30	24	...	...	24	37	36	34	30	24
	130	...	23	31	31	30	29	25	...	...	...	26	30	30	29	25	...
	150	...	24	24	24	24	24	20	...	...	...	24	24	24	24	20	...
	165	...	17	18	18	18	18	16	...	...	...	18	18	18	18	16	...
4.46 10 (3.0)	70	...	...	24	34	30	27	24	18	...	...	...	35	30	27	23	18
	90	...	...	26	29	26	24	20	17	...	...	...	29	27	24	21	17
	110	...	...	27	26	23	20	18	...	...	...	...	25	23	20	18	...
	130	...	...	22	21	19	16	14	...	...	...	...	21	19	17	14	...
	145	...	...	16	16	14	12	...	...	...	...	...	16	14	13	...	...
15 (4.6)	70	...	...	23	28	24	22	19	15	...	...	...	27	24	21	18	14
	90	...	...	20	24	20	18	16	...	...	...	...	24	21	18	16	...
	110	...	...	21	19	17	15	...	...	...	...	...	19	17	15	...	...
	130	...	...	17	14	12	...	...	...	...	...	...	14	...	...	...	...
	145	...	...	11	...	...	...	...	...	...	...	...	...	...	...	...	...
20 (6.1)	70	...	...	21	19	16	15	12	...	...	...	...	...	16	15	...	...
	90	...	...	18	16	14	13	11	...	...	...	...	...	15 <sup>C</sup>	13 <sup>C</sup>	...	...
	110	...	...	...	11	10	...	...	...	...	...	...	...	...	...	...	...

<sup>a</sup>gpm = 0.227 m<sup>3</sup>/h

<sup>b</sup>°C = (°F - 32)/1.8

<sup>c</sup>Suction temperature 85°F (29.4°C)

Source: Schutte and Koerting.



**TABLE 10** Steam consumption of steam-jet siphons, lb/h<sup>a</sup>

Siphon size, in (mm)	Capacity ratio	Operating steam pressure, lb/in <sup>2</sup> (bar) gage							
		40 (2.8)	50 (3.4)	60 (4.1)	80 (5.5)	100 (6.9)	120 (8.3)	160 (11.0)	240 (16.5)
$\frac{1}{8}$ (12.7)	0.125	40	47	54	69	83	97	126	84
$\frac{1}{4}$ (19.1)	0.222	70	83	96	122	147	173	222	322
1 (25.4)	0.346	110	130	150	190	230	270	350	510
$1\frac{1}{2}$ (38.1)	1.000	318	376	434	550	665	780	1,012	1,475
2 (50.8)	1.38	440	520	600	761	920	1,080	1,400	2,040
$2\frac{1}{2}$ (63.5)	2.0	635	750	865	1,100	1,329	1,558	2,020	2,940
3 (76.2)	3.11	990	1,170	1,350	1,710	2,065	2,425	3,145	4,590
4 (102)	5.54	1,760	2,085	2,400	3,045	3,685	4,320	5,500	8,170
6 (152)	12.45	3,960	4,680	5,400	6,850	8,280	9,710	12,600	18,360

<sup>a</sup>Lb/h  $\times$  0.454 = kg/h

Source: Schutte and Koerting.

**TABLE 11** Relative capacities of annular siphons

Capacity of standard 3-in (76.2-mm) siphon, water temperature 100°F (37.8°C), 0 suction lift								
Steam pressure, lb/in <sup>2</sup> (bar) gage	50 (3.45)	75 (5.17)	100 (6.90)	125 (8.62)				
Steam consumption, lb/h (kg/h)	1180 (535)	1620 (735)	2060 (934)	2490 (1130)				
Max back pressure, lb/in <sup>2</sup> (bar) gage at zero flow	12 (0.83)	18 (1.24)	22 (1.52)	35 (2.41)				
Suction capacity, gpm (m <sup>3</sup> /h)	140 (31.8)	130 (29.5)	120 (27.2)	110 (25)				
Discharge pressure, lb/in <sup>2</sup> (bar) gage	5 (0.34)	8 (0.55)	12 (0.83)	30 (2.07)				
Relative capacities of standard sizes								
Size, in (mm)	$1\frac{1}{4}$ (31.8)	$1\frac{1}{2}$ (38.1)	2 (50.8)	$2\frac{1}{2}$ (63.5)	3 (76.2)	4 (102)	6 (152)	8 (203)
Capacity ratio	0.13	0.21	0.30	0.60	1.00	1.85	4.0	7.1

Source: Schutte and Koerting.

Small units (less than 1 gpm, 0.23 m<sup>3</sup>/h) can be supplied for limited discharge pressures, as indicated by Figure 21. With air as the motive fluid, the suction liquid can be very close to its boiling point and only a very slight *NPSH* is required.

When air is used as a motive fluid, the smaller sizes operate more efficiently because the air is more intimately mixed with a suction fluid. In larger sizes, the tendency is for the fluid to be discharged in slugs because intimate mixing does not readily occur. This has a detrimental effect on the performance and especially on available discharge head.

**Air-Lift Eductors** Air-lift pumps are frequently used for difficult pumping operations. Compressed air is forced into the bottom of a pipe submerged in the liquid to be pumped. The expanding air, as it rises up the pipe, entrains the suction fluid.

If compressed air is not available, it is possible to lift water higher than 34 ft (10 m) with the use of an eductor-air-lift combination. Figure 22 illustrates the suction capacity

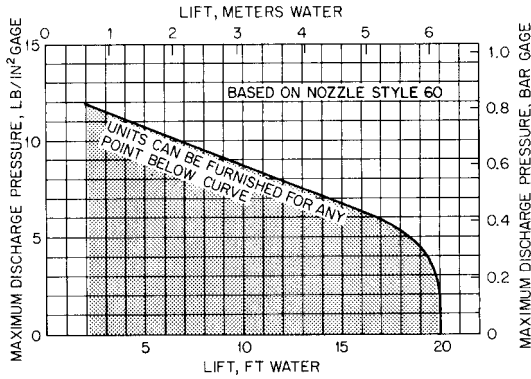


FIGURE 21 Air pumping liquid (Schutte and Koerting)

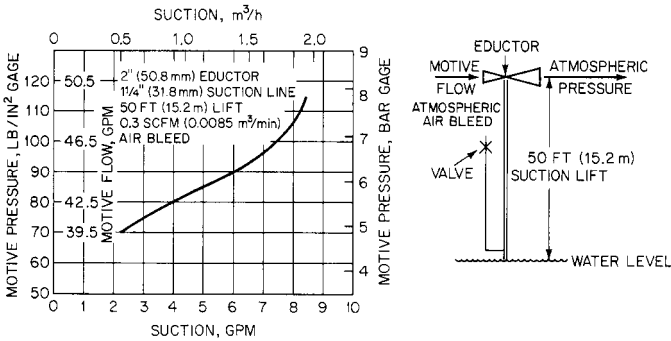


FIGURE 22 Suction capacity of eductor-air-lift combination ( $\text{gpm} \times 0.227 = \text{m}^3/\text{h}$ )

of a 2-in (51-mm) eductor drawing water from a 50-ft (15-m) depth and discharging it to the atmosphere. In operation, an air line from the atmosphere enters the suction pipe near the water level. As the eductor creates a vacuum in this line, atmospheric pressure forces air into the suction pipe. After it is in the line, the rising air carries the suction fluid to the surface and both fluids are discharged to the atmosphere through the eductor.

No sizing data are presented because this type of pump is best specified according to specific conditions.

**Boiler Injectors** The boiler injector is a jet pump utilizing steam as a motive fluid to entrain water, and it is used as a boiler feedwater heater and pump. It differs from a siphon in that the discharge pressure is higher than either motive or suction pressure. This is achieved by the double-tube design shown in Figure 23. In operation, the lower nozzle is activated by pulling the handle partway back. The lower jet creates a vacuum in the chamber, causing water to be induced into the unit. When water is spilling over the overflow, the handle is drawn back all the way. This closes the overflow and simultaneously admits motive steam to the upper jet. This second jet, which is of the straight or forcing type, picks up the discharge from the first jet and imparts a velocity to the water through the discharge tube. The energy contained is sufficient to open the check valve and discharge against the boiler pressure.

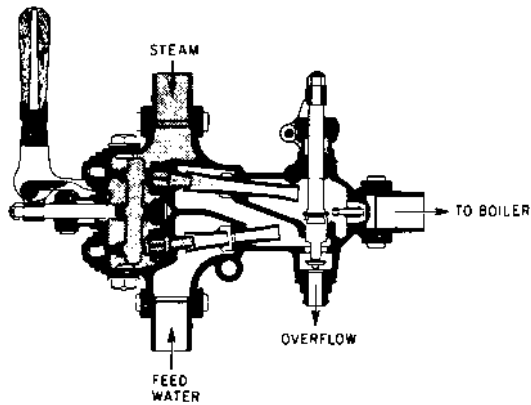


FIGURE 23 Boiler injector, starting position (Schutte and Koerting)

TABLE 12 Capacities of boiler injectors, gph<sup>a</sup>

Size no.	Size iron pipe conn., in (mm)	Size copper pipe OD, in (mm)	Size overflow (drip funnel) pipe, in (mm)	Steam pressure, lb/in <sup>2</sup> (bar)				
				50 (3.45)	100 (6.90)	150 (10.34)	200 (13.79)	250 (17.24)
0	$\frac{1}{4}$ (12.7)	$\frac{3}{8}$ (9.53)	$\frac{1}{4}$ (12.7)	80	100	110	100	90
1	$\frac{3}{8}$ (9.53)	$\frac{1}{2}$ (12.7)	$\frac{1}{4}$ (12.7)	110	140	180	140	130
2	$\frac{1}{2}$ (12.7)	$\frac{3}{4}$ (15.9)	$\frac{3}{8}$ (9.33)	170	210	230	200	190
3	$\frac{3}{4}$ (19.1)	$\frac{1}{2}$ (22.2)	$\frac{1}{2}$ (12.7)	280	340	400	340	320
3 $\frac{1}{2}$	$\frac{3}{4}$ (19.1)	$\frac{3}{4}$ (22.2)	$\frac{1}{2}$ (12.7)	400	470	550	470	440
4	1 (25.4)	1 $\frac{1}{8}$ (28.6)	$\frac{3}{4}$ (19.1)	530	620	720	620	590
5	1 $\frac{1}{4}$ (31.8)	1 $\frac{1}{2}$ (38.1)	1 (25.4)	680	800	920	800	750
6	1 $\frac{1}{4}$ (31.8)	1 $\frac{3}{8}$ (38.1)	1 (25.4)	820	990	1130	990	930
7	1 $\frac{1}{2}$ (38.1)	1 $\frac{3}{4}$ (44.4)	1 $\frac{1}{4}$ (31.8)	1070	1370	1610	1370	1290
8	1 $\frac{1}{2}$ (38.1)	1 $\frac{3}{4}$ (44.4)	1 (31.8)	1400	1800	2100	1800	1700
9	2 (50.8)	2 $\frac{1}{4}$ (57.2)	1 $\frac{1}{2}$ (38.1)	1700	2100	2500	2100	2000
10	2 (50.8)	2 $\frac{1}{4}$ (57.2)	1 $\frac{1}{2}$ (38.1)	2000	2500	2900	2500	2300
11	2 $\frac{1}{2}$ (63.5)	2 $\frac{3}{4}$ (69.8)	2 (50.8)	2500	3000	3500	3000	2800
12	2 $\frac{1}{2}$ (63.5)	2 $\frac{3}{4}$ (69.8)	2 (30.8)	3000	3600	4300	3600	3400
14	3 (76.2)	3 $\frac{1}{4}$ (82.6)	2 $\frac{1}{2}$ (63.5)	3900	4600	5500	4600	4400
16	3 (76.2)	3 $\frac{1}{4}$ (82.6)	2 $\frac{1}{2}$ (63.5)	5000	6000	7000	6000	5700

<sup>a</sup>gph  $\times$  0.00379 = m<sup>3</sup>/h

Source: Schutte and Koerting.

The now obsolete steam locomotives were the largest users of this type of injector. Principal use at present is as a backup to a regular boiler-feed pump. Capacity Table 12 illustrates the range of capacities available for the double-tube injector.

C • H • A • P • T • E • R • 5

# **MATERIALS OF CONSTRUCTION**

---

# SECTION 5.1

---

# METALLIC MATERIALS OF PUMP CONSTRUCTION (AND THEIR DAMAGE MECHANISMS)

---

COLIN O. McCAUL  
RONALD S. MILLER

The requirements for a successful pump installation are *performance* and *life*. Performance is the rating of the pump head, capacity, and efficiency. Life is the total number of hours of operation before one or more pump components must be replaced to maintain an acceptable performance. The initial performance is the responsibility of the pump manufacturer and is inherent in the pump design. Life is primarily a measure of the resistance of the materials of construction to corrosion, erosion, wear, and other factors that can influence the materials when the pump has been placed in service. The need to maximize reliability and extend the pump life makes the selection of appropriate materials of construction crucial.

The selection of materials that are both cost-effective and technically suitable for the application requires a knowledge not only of the pump design and manufacturing processes, but also of the engineering properties of the material, particularly its corrosion and wear resistance properties when subjected to the conditions encountered in the pump. Sufficient information is available in the corrosion and metallurgical literature as well as from the experience of pump manufacturers to make appropriate material choices for virtually any pumping application.

It is known that several factors lead to a long pump life. These include

- Neutral liquids at near-ambient temperatures
- Appropriate material selections for pumps in aggressive services
- The absence of abrasive particles
- Continuous operation at or near the maximum efficiency capacity of the pump
- An adequate margin of available *NPSH* over *NPSH* required as stated on the manufacturer's rating curve
- A low velocity (developed head/rotative speed)

Pumping installations that satisfy all these criteria will have a long life. A typical example would be a waterworks pump. Some waterworks pumps with bronze impellers

and cast-iron casings have a life of 50 years or more. At the other extreme might be a chemical pump handling a hot corrosive liquid with abrasive particles carried in suspension. The life of this pump might be measured in months rather than in years, despite the fact that construction was based on the most resistant materials available.

Most pumping applications fall somewhere between these two extremes. The pump designer needs to be familiar with the various types of degradation that can affect the components of the pump and reduce its useful life. These can be grouped into the general categories of corrosion, wear, and fatigue, with corrosion and wear being the predominant life-limiting mechanisms.

## TYPES OF CORROSION

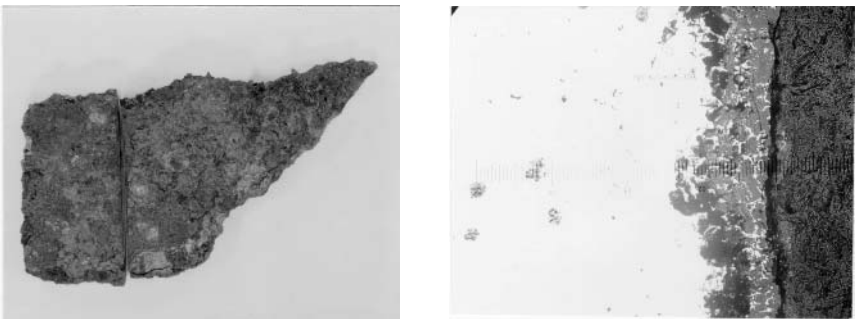
---

**General Corrosion** General corrosion is corrosion that proceeds without an appreciable localization of attack. This type of corrosion occurs on metals or alloys that do not develop an effective passive film on the surface. Usually, the corrosion mechanism is oxidation with the formation of metal oxide corrosion products. General corrosion is most often encountered in pumps with carbon steels and copper base alloys. Cast irons also experience a specialized form of general corrosion, known as *graphitic corrosion*, which will be considered separately.

Carbon steel does not develop a protective oxide film and will corrode at a rate dependent upon several characteristics of the water or other fluid, including temperature, oxygen content, pH, and fluid chemistry. Several empirical indices based on water chemistry exist and can be used to calculate the relative corrosivity of natural waters to carbon steel and similar ferrous alloys. The Langelier Index is best known. The rate of corrosion is also very dependent on velocity and increases with an increasing velocity. In most pump applications, with the notable exception of hydrocarbons, the corrosion rate of carbon steel is too high for this material to provide a useful life. However, carbon steel is frequently used, particularly in vertical pumps, with some form of protective coating to prevent corrosion. Coal tar epoxy is a preferred coating for many water services.

Copper alloys, including both brasses and bronzes, are also subject to general corrosion in the water applications where they are most commonly used in the pump industry. The corrosion rate will be increased by the presence of small amounts of sulfides in the water. Copper alloys gradually develop a protective copper oxide corrosion film in most applications. The corrosion rate gradually decreases over time as this film develops. The rate of general corrosion varies with the specific type or grade of copper alloy. Among the alloys commonly used in pumps, nickel aluminum bronzes have the lowest corrosion rate and best tolerance for higher velocities.

The general corrosion of a Ductile Ni-Resist casing from a vertical pump is shown in Figure 1. A metallographic cross section was removed to show the depth of the corrosion attack.



**FIGURE 1** A small fragment of Ductile Ni-Resist from the lower casing of a vertical pump. The microstructure is also shown on the right side of this figure, illustrating the depth of the corrosion's penetration. This is a classic example of general corrosion (right photo at 100 $\times$ ).

**Dealloying** Dealloying is the preferential removal of one phase from a multi-phase alloy, or one element from a material. Several types of dealloying occur in the pump industry. One of the most common is the graphitic corrosion of gray cast iron. This material is low cost, easy to machine, and well suited for a variety of applications, especially in the waterworks industry. It is probably the most widely used material in the pump industry.

Gray cast iron corrodes by a fundamentally different mechanism than carbon steel or ductile cast iron. The structure of gray cast iron consists of interconnected graphite flakes in a matrix that is predominantly iron. In the presence of an electrolyte, which is usually water, a galvanic cell is established between the iron and graphite. The iron corrodes, and the corrosion products are largely flushed away with the fluid passing through the pump. The original casting is gradually reduced to a porous graphite structure that may contain some iron oxide corrosion product. This is frequently referred to as *graphitization*. The surface of a gray iron casting that has suffered graphitic corrosion will retain its original shape and dimensions, but the surface will be largely graphite, which can be cut with a knife. The casting will lose some fraction of its mechanical properties and become increasingly susceptible to brittle failure, resulting from modest shock or impact loads. This is also the corrosion mechanism for Ni-Resist in seawater. Figure 2 shows the interface between the sound base metal and the graphitized front.

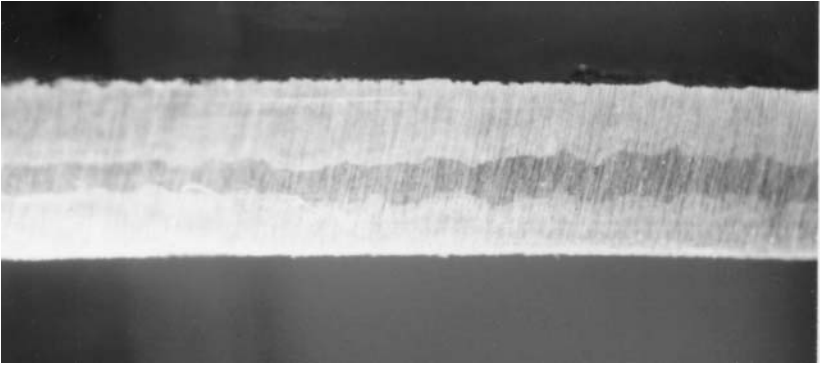
It is important to recognize that the rate of graphitic corrosion varies with the water chemistry, and that this type of corrosion can occur in both fresh and salt waters. The high conductivity of salt water corresponds to a higher corrosion rate. Graphitic corrosion will proceed at a slower pace in waters that have a high mineral content. Minerals tend to plug the graphitic layer on the surface, sealing off the base metal from exposure to the fluid, thereby reducing the corrosion rate.

As the surface of a cast-iron component, such as a pump casing, gradually graphitizes, the galvanic relationships with other components within the pump will be altered. It has been observed that the bronze impeller originally supplied in a cast-iron pump handling seawater will provide a significantly longer life than bronze impellers that are installed after the pump has been in service for several years. The reduced life of the replacement impellers is caused by an altered galvanic relationship with the pump casing. Initially, the casing was cast iron, which is anodic to a bronze impeller. With time, as the casing graphitizes, it gradually becomes cathodic, due to the influence of the graphite. The bronze impeller is now the anode and corrodes at a much higher rate. This example highlights the influence that graphitic corrosion can have on other components within the pump and the importance of carefully selecting materials for use in conductive fluids, such as salt water.

Several other types of dealloying can also occur in pumps. Brass and bronze alloys containing more than about 14 percent zinc are subject to a form of dealloying known as *dezincification*. The zinc is preferentially corroded from the matrix of the material, leaving a spongy, copper-rich residue. Dezincification can occur either uniformly in a shallow layer



**FIGURE 2** The interface between the advancing graphitized front and the sound base metal. Graphitic corrosion propagates along the path of the graphite flakes (50 $\times$ ).



**FIGURE 3** The dealloying of a vertical turbine pump impeller. Note the change in color across the cross section. The unaffected bronze (light color) material is surrounded by a dezincified layer (1.3 $\times$ ).

over the surface of the casting or as a distinct plug confined to a small area. Plug-type dezincification is a more serious problem because the plug is weak and will cause leakage if it penetrates a pressure boundary, but it should be emphasized that copper alloys containing less than 14 percent zinc are not susceptible to this form of corrosion. Consequently, the requirement often imposed upon pump manufacturers for zinc-free bronzes to avoid dezincification is without technical justification. Figure 3 shows the dealloying of an impeller.

The final type of dealloying that occasionally occurs in pumps is dealuminification in aluminum bronzes. These are metallurgically complex materials. Some compositions can form an aluminum-rich phase that can be preferentially corroded in aggressive fluids, especially seawater. The detrimental phase can be mitigated by a special heat treatment known as *temper annealing*. This heat treatment must be specified by the designer for susceptible compositions, because it is not a mandatory requirement of national material specifications. The chemistry of some aluminum bronze alloys from Europe has been adjusted to preclude the formation of the detrimental aluminum-rich phase without the need for the temper annealing heat treatment. The temper anneal can serve as a stress relief operation for fabricated aluminum bronze structures, which is a secondary benefit for products in this category.

**Galvanic Corrosion** *Galvanic corrosion* refers to the corrosion that occurs when one alloy is electrically coupled to another and exposed in a conductive liquid. Usually, the corrosion rate of the more noble alloy will be less than if it were exposed uncoupled. The corrosion rate of the less noble material will be greater than if it were exposed uncoupled.

Several factors influence the rate of galvanic corrosion of both metals. This corrosion is greatly influenced by the conductivity of the fluid. In a fluid such as fresh water, which has a low conductivity, galvanic corrosion will be less severe and generally confined to the immediate location where the metals contact one another. However, in a highly conductive fluid, such as seawater, galvanic corrosion will be more severe and will occur over a wider area. The pump designer needs to consider the possibility of such corrosion when using dissimilar metals in a conductive fluid.

Galvanic corrosion problems in seawater and other conductive fluids can be avoided by the careful use of materials. Galvanic corrosion is related to the area ratios of the coupled metals. It is always desirable to have the area of the anode, or less noble metal, equal to or greater than that of the more noble metal. In this way, the additional corrosion experienced by the less noble metal will be spread over a relatively large area and will not be excessive because of being coupled. An example of the effective use of this galvanic relationship involves centrifugal pumps having a Ni-Resist casing and austenitic stainless steel internals. This combination is often specified for seawater services. The Ni-Resist is



anodic to the stainless steel and will protect it from localized corrosion when the pump is shut down and contains stagnant water. The area of Ni-Resist is considerably larger than that of stainless steel. The increased galvanic corrosion of the Ni-Resist is spread over a large area and is negligible.

The amount of corrosion that will occur in a galvanic couple also depends on the freely corroding potentials of the coupled metals. Less corrosion-resistant metals, such as zinc, cast iron, and steel will usually have more negative potentials when measured against a standard reference electrode. More corrosion-resistant metals, such as stainless steels, will have less negative potentials.

The corrosion potentials for many commonly used engineering alloys in slowly moving seawater are shown in Table 1. The alloys are listed in the order of the potential that they exhibit in flowing seawater. Certain alloys (indicated by solid colored boxes preceding the name of the alloy) in low-velocity or poorly aerated water and at shielded areas may become active and exhibit a potential near  $-0.5$  volts. The extent of galvanic corrosion that will occur when two metals are electrically coupled will depend on the potential difference between the metals. The corrosion rate of zinc coupled to stainless steel will increase dramatically because of the large potential difference between these two metals. A nickel aluminum bronze coupled to austenitic stainless steel will experience little galvanic corrosion because the potentials of these two metals are close to one another. The pump designer needs to be aware of the corrosion potentials of dissimilar metals used in conductive fluids in order to avoid unanticipated galvanic corrosion problems.

The use of coatings can decisively alter the galvanic relationships in a pump. If the more anodic component, such as a steel casing, is coated, one can expect a high rate of corrosion at those locations where the coating eventually begins to fail. This will be caused by a very unfavorable area ratio, with a small area of exposed carbon steel coupled to a large area of some more noble metal, such as stainless steel or bronze. For this reason, coatings should be employed with caution in pumps handling conductive fluids that are constructed of dissimilar metals. It is generally advisable in these applications not to coat the anodic component. Figure 4 documents the galvanic corrosion on the interior diameter of a carbon steel flange connected to a stainless steel shroud. The accelerated corrosion is due to the unfavorable ratio of stainless steel to carbon steel in this component.

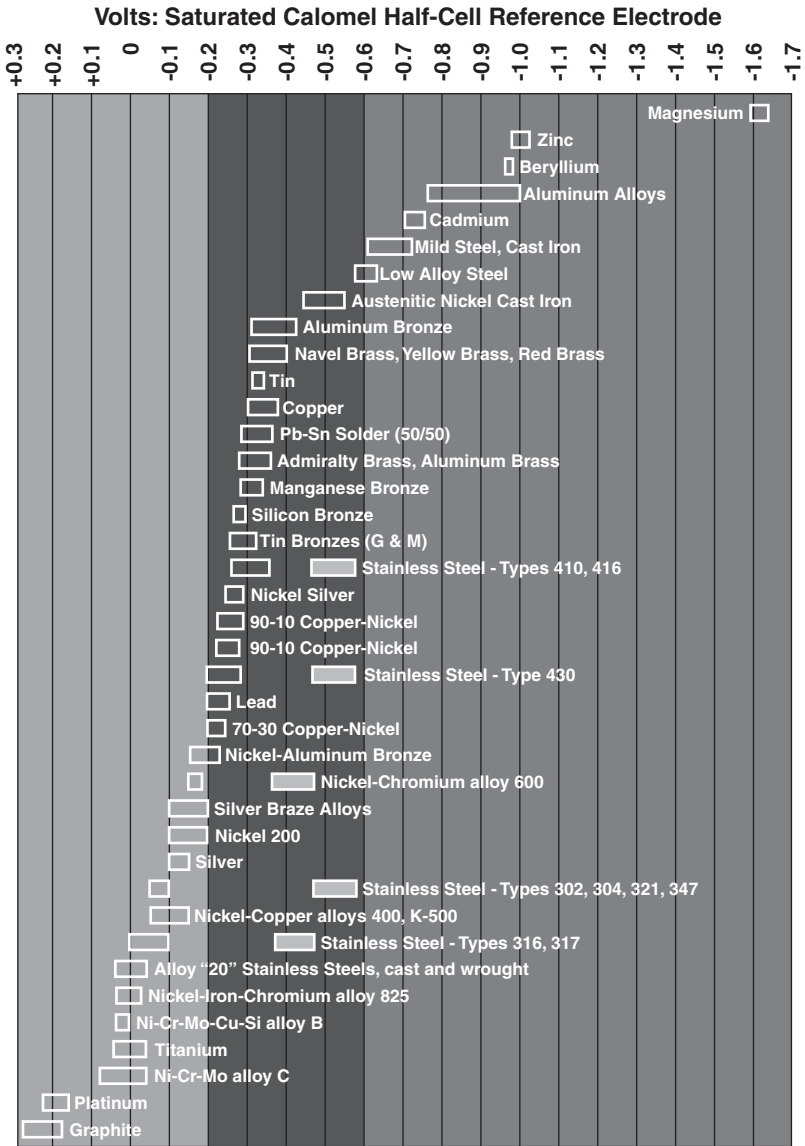
**Stress Corrosion Cracking** *Stress corrosion cracking* (SCC) is a particularly dangerous form of corrosion because it is not easily detected before it has progressed to such an extent that it can cause sudden catastrophic damage. Although relatively uncommon in pumps, it can occur in several classes of materials. The pump designer should be aware of the potential combinations of material and environment that can cause SCC.

Stress corrosion requires that several factors be present. These include tensile stress, which can be either residual or applied, a susceptible material, an environment capable of causing stress corrosion, and time.

The materials used in the pump industry that may experience SCC include austenitic and martensitic stainless steels, some copper base alloys, and, occasionally, Ni-Resist. The austenitic stainless steels are susceptible to stress corrosion in aqueous chlorides at temperatures above about  $140^{\circ}\text{F}$  ( $60^{\circ}\text{C}$ ). Cast alloys, which contain some fraction of ferrite in the microstructure, are significantly more resistant to stress corrosion than their wrought counterparts. The possibility of cracking is increased in situations where chlorides are concentrated, as by evaporation. High residual stress, often present in as-welded structures, also enhances the possibility of cracking. Increasing nickel content in austenitic stainless alloys enhances the resistance to SCC. The high nickel grade, commonly known as Alloy 20, is often used in chemical applications where the optimum resistance to stress corrosion is necessary. The SCC of austenitic stainless steels in pumps is relatively uncommon.

Martensitic stainless steels are susceptible to cracking in the presence of hydrogen sulfide and is often referred to as *sulfide stress corrosion cracking* (SSC). These steels, particularly CA-15 and CA-6NM, are commonly used in pumping applications in oil production and refining where hydrogen sulfide can be present. SCC can be avoided by giving these materials a special heat treatment intended to reduce hardness below a certain threshold level, below which cracking will not occur. This has also been correlated to the yield strength of a material. It is often seen in literature that ferrous materials used

**TABLE 1** Corrosion potentials in flowing seawater (8–13 ft/s, 50–80°F/2.4–4.0 m/s, 10–26°C)



in these services should have a hardness no greater than 22  $R_c$  or a yield strength no higher than 90,000 lb/in<sup>2</sup> (620MPa). Technical standards, including API 610 and NACE MR-01-75, can be used to specify appropriate requirements for martensitic steels, which will be used in environments containing hydrogen sulfide.



**FIGURE 4** Galvanic corrosion is evident on this pump section. Note the high corrosion rate on the interior diameter of the carbon steel flange that is attached to the stainless steel shroud.

Copper alloys are susceptible to SCC in the presence of ammonia, although considerable variations take place in the susceptibility of the various types of bronzes, with aluminum bronzes being the most resistant. Polluted natural waters can contain ammonia, and for this reason, bronze pumps are usually not a good choice for these applications.

High-strength manganese bronzes are susceptible to cracking in natural waters. Cast impellers in these alloys have been known to suffer severe cracking. Residual stress in the casting may also be sufficient to induce cracking. These alloys should not be used in pumps because of their susceptibility to such problems.

Ni-Resist is an austenitic cast iron that contains 15 to 20% nickel. This material is commonly used in large, seawater vertical pumps. Experience has shown that it is subject to SCC, especially in the diffuser section of these pumps, unless the castings are furnace stress-relieved. This must be specified by the purchaser, as it is not a requirement of national material specifications.

**Hydrogen Embrittlement** Hydrogen damage is a form of environmentally assisted failure that results from the combined action of hydrogen and residual or applied tensile stress. Hydrogen damage to specific alloys or groups of alloys manifests itself in many ways, such as cracking, blistering, hydriding, or as a loss of tensile ductility. Collectively, these various forms of damage are often referred to as *hydrogen embrittlement*.

Damage caused by hydrogen is occasionally encountered in pumps. Some plating processes, such as chrome plating, which is often used to rebuild pump shafts, generate hydrogen. This hydrogen can enter the surface of the metal. Microscopic cracks can occur in higher strength steels (greater than a 90,000-lb/in<sup>2</sup> or 620-MPa yield strength). Abusive grinding can work-harden the surface of lower strength steels and increase the probability that hydrogen will cause cracking. Microscopic cracks resulting from hydrogen damage act as stress risers and can propagate failure catastrophically by mechanical fatigue. This problem can be avoided by utilizing proper grinding practices before plating. Higher strength steels should be baked, to drive off hydrogen, immediately after plating.

Hydrogen can also be introduced into metals during welding. In order to avoid the hydrogen damage associated with welding, ferritic and martensitic steels should be welded with low hydrogen electrodes. Coated electrodes should be baked, in accordance

with manufacturer's instructions, prior to usage in order to drive off moisture, which is the major source of hydrogen contamination of welds.

**Microbiologically Induced Corrosion** Living organisms can promote corrosion in many different environments. A variety of biological organisms thrive in both aerobic and anaerobic environments. Corrosion attributable to microbiological activity occurs most frequently in stagnant water, which remains in a pump when it is shut down for an extended length of time.

Sulfate-reducing bacteria are found in many waters. They will form slimy, reddish hemispherical shaped mounds or colonies on cast iron or carbon steel. These are known as *tubercles*. If scraped off, there will invariably be a saucer-shaped pit beneath the tubercle. The inside of the pit will contain a wet, black deposit. The pitting is caused by traces of sulfuric acid excreted by the bacteria. This type of corrosion will usually not result in premature failure.

Several more serious types of microbiologically induced corrosion afflict stainless steels. A certain class of metal ion concentrating/oxidizing microbes appears to concentrate ferric and manganic chlorides, both of which are potent pitting agents. These bacteria form colonies preferentially at welds in austenitic stainless steels and are capable of causing severe pitting corrosion in a relatively short time. This problem has been encountered in a variety of equipment in both salt and fresh water. It is often discovered only when the welds begin leaking. Pumps employing welded stainless steel fabrications can be afflicted by this problem if permitted to sit idle with stagnant water, either fresh or salt, for an extended period. Biocides can be used to mitigate this problem in some instances.

Finally, the decay of biological organisms can generate hydrogen sulfide, which adversely affects the protective oxide film on copper base alloys. The enhanced biological activity in warmer tropical waters, especially under stagnant conditions, can impair the corrosion resistance of bronzes and reduce the threshold velocity at which accelerated corrosion will occur. Bronzes should be used with caution in applications where microbiological activity is anticipated and the possibility of extended shutdowns is possible.

**Intergranular Corrosion** This infrequent type of corrosion preferentially attacks a material at the grain boundaries. This is caused by local chemical differences such as the chrome-depleted regions of an austenitic stainless steel. Bronze alloys susceptible to this type of corrosion include aluminum bronzes, silicon bronzes, Muntz metal, and admiralty metal. Two things are necessary: a sensitized material and a corrosive media, such as seawater. Sensitization can occur during heat treatment or more commonly during weld repair. This type of corrosion often leads to corrosion-assisted fatigue cracks when cyclic loading is present.

The improper heat treatment of 300 series austenitic stainless steels can result in sensitization to intergranular corrosion. Sensitization occurs when stainless steels that contain more than .03% carbon are held at temperatures between 800 and 1550°F (between 425 and 850°C). At these temperatures, chrome carbides precipitate along the grain boundaries, resulting in chrome depletion in the adjacent areas. These adjacent areas have reduced corrosion resistance. Austenitic stainless steels contain approximately 16 to 18% chrome. The chromium content in the areas surrounding a chrome carbide particle can drop below the 12% necessary to maintain a passive state. A galvanic cell is set up with a large cathode (grains) and a small anode (grain boundaries). In this undesirable scenario, corrosion occurs along the anodic grain boundaries. The extent of the corrosion damage depends on the length of time held within the sensitization temperature range. The degree of sensitization is a function of the carbon content; the higher the carbon content, the shorter the period of time the material can be held within this range without sensitization occurring. A graph of the temperature versus time for various carbon contents illustrates this point in Figure 5. Intergranular corrosion of an improperly heat-treated stuffing box cover is shown in Figure 6.

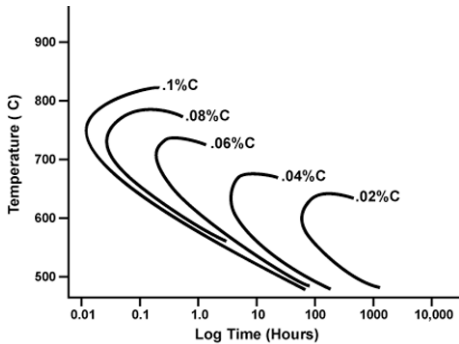
Austenitic stainless steels can also be sensitized during normal welding procedures. Care must be taken to avoid the sensitization range during welding followed by proper post-weld heat treatment when necessary.

Sensitization can be avoided or corrected by several methods:

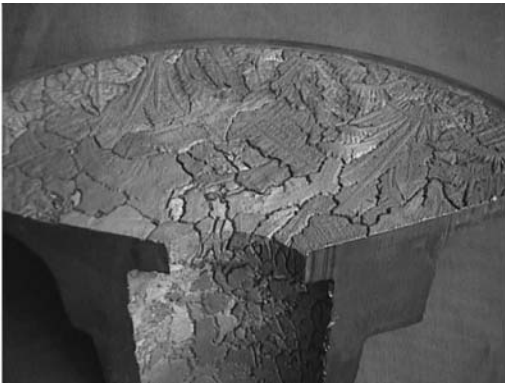
- Heat the material to a temperature high enough to dissolve the chrome carbides, typically 1900 to 2100°F (1040 to 1150°C), followed by rapid cooling through the sensitization range. Localized heat treatment of welded areas will not desensitize a material.
- Use a stainless steel that is stabilized by the addition of niobium or titanium. These two elements will tie up the carbon, thus preventing chrome carbides.
- Reduce the carbon content to a low level (less than .03 percent). The lower the carbon content, the longer it takes chrome carbide precipitation to occur.

When austenitic stainless steels are necessary in the pump industry, materials commonly used in services where intergranular attack is anticipated include 316L, 304L, CF-3, and CF-3M. Intergranular corrosion is not a concern in alloys containing 25% or more chromium.

**Cavitation Erosion** Cavitation erosion is primarily a mechanical process, although it acts synergistically with corrosion and is often considered with other forms of corrosion. Cavitation erosion can be defined as metal removal from the surface caused by high



**FIGURE 5** Time-temperature sensitization curves as determined by the Strauss Test for 18-8 stainless steel. Note that a low carbon grade of stainless (0.03% C) requires five to 10 hours exposure, while a standard grade (0.08%) need only minutes of exposure time.



**FIGURE 6** The surface of a stuffing box cover that experienced intergranular corrosion due to sensitization. The grains are clearly evident on the interior of the bore as well.



**FIGURE 7** Cavitation erosion of an impeller, indicated by the porous appearance of cavitated regions on the surface

stresses associated with the collapse of vapor bubbles in the fluid. Cavitation occurs in a pump when the local pressure of the fluid is reduced to the vapor pressure. In a multi-stage pump, vapor bubbles form in the low-pressure areas at the impeller inlet and are swept by the flow into regions of higher pressure where they collapse. A great many bubbles may form and collapse in a small area, producing many microjets of high kinetic energy. The energy released by the bubble collapse is expended as impact loading on the metal surface. This situation is aggravated if protective oxide films are present because these are damaged, exposing fresh metal to the corrosive action of the fluid. This cyclic loading eventually causes the formation of microscopic fatigue cracks. These cracks propagate and intersect, resulting in the removal of metal from the surface and the characteristic spongy or porous appearance of cavitation damage. An example of a cavitated impeller is shown in Figure 7.

Although every effort should be made in the design and application of centrifugal pumps to prevent cavitation, it is not always possible to do so at capacities less than the rated maximum efficiency capacity of the pump. It must be recognized that at a low flow operation, the stated *NPSH* required curve is not usually sufficient to suppress all cavitation damage. The stated *NPSH* required is that needed to produce the head, capacity, and efficiency shown on the rating curve. At low flows, some cavitation damage should be expected. It may be impractical to supply an *NPSH* that would suppress all cavitation at these low flows, as it could be many times that it is required at the best efficiency point. Therefore, the possibility of cavitation damage frequently becomes a consideration when selecting material for impellers.

Open-type mixed flow impellers that produce heads in excess of 35 ft (10.7 m) are particularly susceptible to cavitation erosion in the clearance space between the rotating vanes and the stationary housing. This is usually referred to as *vane tip erosion* and is caused by a cavitating vortex in the clearance space between the vane and the housing. It is also impractical in this instance to provide sufficient *NPSH* to eliminate the cavitation. Any evaluation of the impeller and housing for a pump of this type should include the possibility of vane tip erosion.

It was conventional wisdom in the pump industry until recent years that the cavitation resistance of a material was directly related to its hardness. A more sophisticated under-

standing has been developed in recent years that has led to the development of a new class of nonstandard stainless steels with exceptional cavitation resistance.

The relationship between cavitation resistance and hardness was first critically investigated in the 1970s when it was observed that cobalt base alloys of a modest hardness developed a very high resistance to cavitation damage. Cavitation resistance was related to the capability of the material to transform at the surface when subject to cavitation loading into a harder, more resistant metallurgical phase. This work was extended to austenitic stainless steels, whose chemical composition was adjusted to promote the formation of a stress-induced martensite under cavitation loading. New alloys were developed initially as weld filler metals to repair cavitation damage and later as impeller castings for pumps. These alloys have relatively low hardness in the solution-annealed condition, comparable to standard austenitic grades, but transform to a much harder martensite at the surface upon exposure to cavitation loading. The hard surface layer resists the initiation of fatigue cracks. If these cracks eventually develop after extended exposure to cavitation bubbles, propagation into the soft ductile base metal is difficult. Cavitation-resistant austenitic stainless steel castings, alloyed with chrome and manganese, develop cavitation resistance similar to that of cobalt base alloys.

Extensive laboratory tests of the resistance of a wide range of materials to cavitation erosion have produced data for all the materials commonly used in centrifugal pump construction. It is possible to make a good correlation between the laboratory data and field experience to develop the following tabulation of the cavitation-resistance properties of pump materials, listed in order of decreasing cavitation resistance:

- Stellite
- Chrome-manganese austenitic stainless
- Carburized 12% chrome stainless casting
- Titanium 6AL-4V
- Cast nickel-aluminum bronze
- Cast duplex stainless steel
- Cast precipitation hardening stainless steel
- Ductile NiResist
- Cast CF-8M
- Cast CA6-NM
- Cast CA-15
- Monel
- Manganese bronze
- Carbon steel (cast)
- Leaded bronze
- Cast iron

Selecting materials with adequate cavitation resistance will afford the pump designer much greater leeway in the range of conditions under which the pump can be operated. It also permits the design of smaller, lighter pumps that can be operated at higher speeds. The judicious use of materials significantly extends the time between outages caused by cavitation damage and can dramatically reduce maintenance costs.

## **TYPES OF WEAR**

---

Rotating equipment, including pumps, can suffer from damage as a result of mechanisms unrelated to corrosion. The relative motion between parts that are in close proximity to each other can produce wear when these components come into contact with one another.



Catastrophic damage may occur if the parts make contact under high loading conditions or when foreign bodies are entrapped between the rotating and stationary components. An accelerated material loss or catastrophic seizure of these components can result in costly repairs or replacements. Erosion, due to the presence of solid particles in the liquid being pumped, can also limit the life of internal pump components.

Wear mechanisms have been categorized into more than 20 individual processes.<sup>1</sup> However, only a few mechanisms are frequently recognized as damaging to a pump:

- Adhesive wear: material-to-material contact
- Abrasive wear: solids interacting with internal components
- Erosion: solid particle impingement
- Fretting: small amplitude motion of parts causing oxidation damage

Identifying the wear mechanism is somewhat difficult at times as wear, or the loss of material, within a pump can result from more than one mechanism at a time.

The study of friction and wear as a science, known as *tribology*, had its beginning in the late 1930s. These early studies fostered an increased awareness of wear damage mechanisms that, in addition to corrosion and material fatigue, account for the life-limiting factors of pumps. Additional information on the study of wear can be found in current trade journals and texts.

**Adhesive Wear** One of the primary causes of material loss on rotating components in a pump handling clear liquids (with no solids entrained in the fluid stream) is adhesive wear. This material loss is due to material-to-material contact producing surface disruptions, material grooving, a transfer of material, and possibly galling. Two important characteristics to consider for a pair of materials that may come into contact are their adhesive wear traits and their galling threshold. Galling of a material is considered a severe case of adhesive wear.

The wear of two surfaces in relative motion is complex. Some alternative theories of sliding wear have been proposed in addition to the adhesive wear model. They are the delamination theory, the oxidation theory, the surface delamination theory, a fatigue model, and combinations of several of the theories mentioned. However, only the adhesive wear theory offers a general wear equation to quantitatively predict wear, thus providing a means to rank materials with respect to their wear characteristics.

A multitude of adhesive wear tests exist, including ring and block, pin and vee block, 4-ball, and pin on disk. Wear tests are performed in order to screen material combinations for potential usage. Therefore, wear tests are designed to simulate, as closely as possible, the actual service conditions and parameters.

The wear testing of materials under adhesive wear conditions has resulted in several generalities that are safeguards to the successful use of materials that may experience contact during service. Studies supported by EPRI, U.S. Naval research, and private industries result in lists of materials that are considered acceptable with regard to wear compatibility when contact does occur. From this testing, the material's hardness is determined to be the critical parameter for successful running combinations. The following guidelines should be used when selecting materials for services where adhesive wear is expected:

1. Like materials are not expected to run well under adhesive wear conditions (except for materials designed for antigalling resistance such as Nitronic 60 and Waukesha 88).
2. Combinations with hardness values less than  $45 R_c$  require a hardness differential of at least  $10 R_c$ .
3. Combinations with hardness values greater than  $45 R_c$  can have the same hardness.

Based upon extensive empirical testing and field experiences, several sound rules of thumb have been developed through the years when selecting pump wear ring materials. Three factors are used to select materials for wear surfaces in clear liquid environments:



- Corrosiveness of the fluid
- Amount of wear allowed
- Galling stress

Corrosion determines the class of material to be used. These classes generally fall into three groupings: non-corrosive, mildly corrosive, and corrosive. Of course, additional constraints occur when selecting an appropriate material within the corrosive material grouping that will need to be addressed by application experience.

Other material characteristics, such as additives, can significantly affect performance with regard to adhesive wear and galling. For example, copper alloys with lead additions are considered to be bearing alloys because of the capability of the lead to provide lubricity between contacting surfaces. Alternatives are being evaluated today to replace leaded bronze alloys to avoid the health considerations of lead usage. This is also true of tin and bismuth additions to nickel-based alloys.

A general guide for materials in several environments is as follows:

Environment	Materials	Hardness
Non-corrosive	Cast iron/leaded bronze	Unimportant
Mildly corrosive	Martensitic stainless steels (locally or through hardened)	Less than 45 $R_c$ , 10-point differential Greater than 45 $R_c$ , same hardness acceptable
Corrosive	Corrosion-resistant, non-galling austenitic stainless steel (Nitronic 50/Nitronic 60 or Waukesha 88/Nitronic 50)	Not applicable
Severely corrosive	Highly alloyed austenitic stainless steel with hard-faced materials such as Stellite or Colmonoy	Not applicable

Using these industry-wide accepted rules of thumb will help avoid catastrophic damage normally resulting in costly repairs.

Some special applications have produced unique material applications for given environments. These include low specific gravity applications where the use of mechanical carbon materials is desirable because of the non-lubricating nature of these fluids. Common practice is to make the stationary component metal-filled graphite if the specific gravity is 0.5 or less. Stationary mechanical carbon components are also used in liquid  $CO_2$  services and other potential dry start applications, such as the upper bearing in vertical pumps. Currently, non-metallic wear components, such as advanced polymers and ceramics, are being looked at to solve nagging problems encountered in a variety of applications. Usually, these are glass-filled polymers or ceramic composites with various additives to enhance their wear resistance.

**Fretting** Fretting can be considered a special case of adhesive wear. It occurs when two parts in contact experience a repeated, small amplitude relative motion between close-fitting surfaces such as a loose impeller on a shaft. Researchers have described fretting damage as a four-stage event:<sup>2</sup>

1. Adhesive wear of the asperities on the mating materials
2. Abrasive wear caused by the wear debris produced in step one
3. Abraded particles filling the asperity valleys
4. Elastic contact producing cold working of the surface and micro-pitting

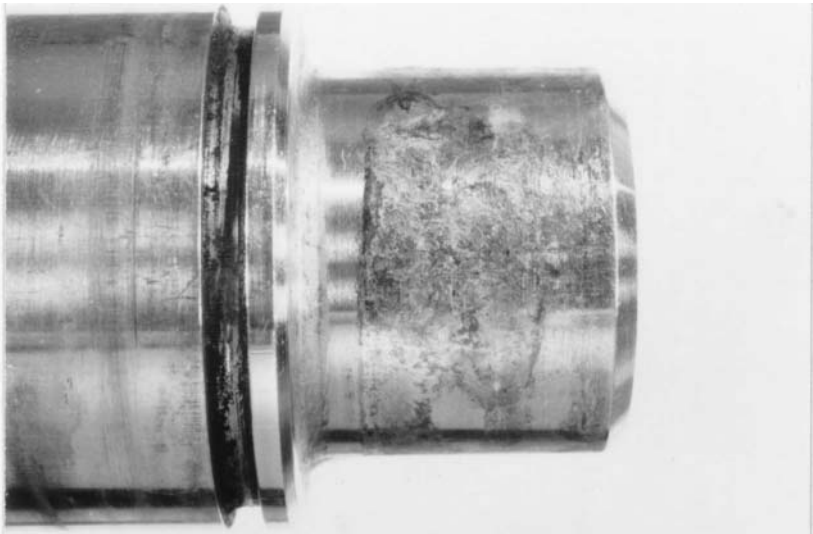
In a pump, there is the potential for small amplitude motion at loose fitting impellers, beneath loose bearings, and between impeller wear rings and the impeller hub. The design engineer does not intentionally create a circumstance that will generate this type of motion, but when it occurs, fretting damage can lead to other problems.

Fretting can be identified by a red powdery oxide that forms along the fretted surface. In a pump, the red-colored debris is often washed away, but a distinct damaged surface appearance will develop on the fretted surfaces. This damage is often described as having a mottled appearance and is best depicted as a flat, eroded surface with no directionality to the damage. Although the oxide may be washed from the surface, some staining of the adjacent component can be observed after disassembly of the pump. This has led to the misinterpretation that fretting is a corrosion mechanism, but it is actually a special wear phenomenon.

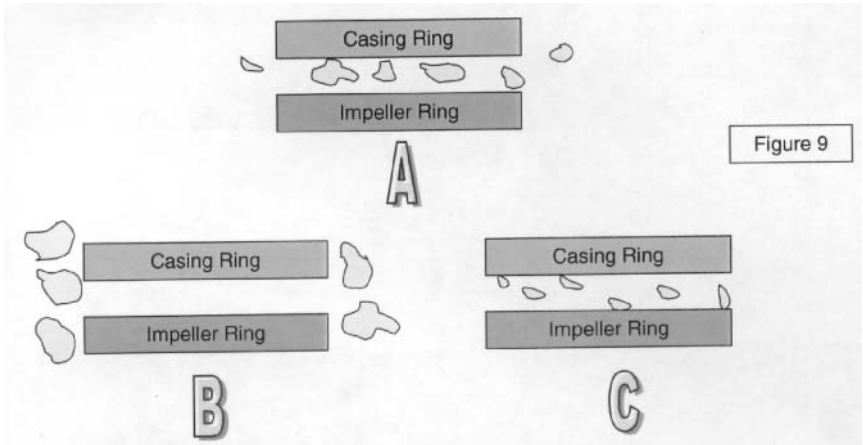
Figure 8 shows the fretting damage of a pump shaft along the impeller-fitted area where a loose fit enables the oscillation of the impeller during operation. Since the motion necessary to cause fretting can be of a small amplitude, large vibrations in the pump may not be present. This makes the detection of fretting during any operation impossible. The impeller in this example would have similar damage along its bore.

Fretting damage can be avoided with a few relatively simple guidelines. You should eliminate or prevent the possibility of motion between the two components by either tighter clearances, or shrink fitting the assembly, which increases the clamping force. If fretting is unavoidable in a particular design, methods of mitigation can be used. These include various coatings or providing the contact zone with an appropriate lubricant. Coatings that may be used include flame-sprayed high-nickel alloys, silver plating, or possibly adding a thin, dense chrome plating to one or both of the faces in contact.

**Abrasive Wear** Abrasive wear is often categorized into two main classifications: *two-body* and *three-body wear*. The name indicates the mechanism of wear. For the most part, three-body abrasive wear is the primary mechanism of damage in centrifugal pumps. This can occur when hard solid particles entrained in the fluid enter between ring fit areas or impeller keyway faces. In fluids with high concentrations of solids, another form of three-



**FIGURE 8** The fretting damage of a shaft beneath an impeller that experienced small amplitude motion. The mottled appearance is typical of the damage caused by fretting (2.2 $\times$ ).



**FIGURE 9** Three possible conditions between wear surface clearances and solid particle size. Condition "A" is conducive to maximum three-body abrasive wear.

body wear is produced. Solids carried in the fluid stream can strike the internal pump surfaces. This is more commonly referred to as *erosion*. This type of damage is observed in the impeller and cutwaters of the casing. The degree of material damage, due to this mechanism, depends upon the bulk hardness of the material, the carbon content, and the characteristics of the solids present. Important particle characteristics include size, shape, hardness, and mass.

To minimize three-body abrasive wear, a couple of variables must be taken into consideration. The wear ring clearance influences damage. The relationship between the size of the particles in the fluid stream and the gap into which they can enter is important. This is graphically illustrated in Figure 9, which shows three types of particle-to-gap relationships. Condition A is logically the most damaging three-body abrasive case. A high rate of damage will result as these particles are entrapped between the two components. In condition B, large particles relative to the ring clearance will not enter and produce damage. This condition enables the particles to flow with the fluid stream through the eye of the impeller and exit the pump. In condition C, very fine or relatively small particles will not be entrapped and ground between the rings and will not result in collateral damage of the components.

For the most part, particles in a fluid service will be in a range of sizes, so all the conditions will exist. Typically, a particle size and distribution analysis is performed to characterize the amount of particles that will cause condition A to exist. This is relatively simple to accomplish by extracting the solids from a fluid sample and performing a sieve analysis. The percentage of solids present in the fluid stream is extremely important for determining the appropriate material and design considerations. This will be addressed later with guidelines given for appropriate material selections.

Wear particle hardness is also extremely important. If particles are soft and friable, such as talc, little damage would be expected to occur on metal pump components because of three-body abrasive wear. The amount of damage is expected to be greater if the particles are extremely hard. These particles include welding scale or silicon dioxide ( $\text{SiO}_2$ ), which is sand. The particle geometry also contributes to the amount of damage that can result in three-body abrasive wear. Often, particles of  $\text{SiO}_2$  are found in a rounded condition. Pumps used to handle river water or seawater on ships frequently encounter these configurations. Hard, round particles are less damaging than particles of equal hardness with sharp, angular configurations. Fly ash, a very hard, sharp, angular particle, is one of the most abrasive services encountered in the pump industry.

A material's resistance to abrasive wear can be characterized by a standard ASTM test procedure. Each testing procedure attempts to simulate the mechanism that most appropriately addresses the class of abrasive wear. In general, materials that are resistant to two-body abrasive wear are resistant to three-body abrasive wear also.

Test results show that the primary property responsible for increasing resistance to abrasive wear is the hardness of a metal alloy. Zum Gahr has provided test results to graphically illustrate this fact.<sup>3</sup> Small microstructural differences, alloying, and surface-condition differences within alloy groups also can influence the abrasion resistance of a material. Some of these conclusions include the following:

- Abrasion resistance is increased with increasing bulk material hardness.
- At the same bulk hardness, steels with higher carbon content have higher abrasion resistance.
- Cold working, which increases a material's surface hardness, does not significantly increase the abrasion resistance of the alloy.
- Precipitation hardening increases the bulk material hardness and abrasion resistance of an alloy.
- Gray cast irons show a decreasing abrasion resistance at higher hardnesses.
- Softer, austenitic, white cast irons exhibit improved abrasion resistance over martensitic, white cast irons.
- Carbides are important for the wear resistance of steels and chromium-alloyed, white cast irons.
- A carbide volume fraction of 30% maximizes the abrasive wear resistance for materials with a soft matrix.

An example of three-body abrasive wear is shown in Figure 10. It shows a laser-hardened shaft sleeve after approximately one year of service in a mine dewatering operation where abrasive wear caused a significant wear of other material combinations. The abrasive wear was caused by fine tailings in this gold mine application. To increase the life of rings in services like this, the use of hardened wear rings is a good start. This is the reason why pump producers use coated rings in applications where significant abrasive wear is anticipated. However, depending upon the severity of the service, a choice of a ring material containing carbides may be necessary.

For mildly abrasive services, the following materials should be considered:

- Ni-Resist—Its resistance is due to chromium carbides in the matrix. It has good adhesive wear resistance also.
- Selectively hardening the surface of AISI 420 (laser hardened 50–55  $R_c$ ). Surface hardening is not susceptible to hydrogen embrittlement or SCC.
- Carburized and hardened 12% chromium stainless steel.

For more abrasive services, the following is often considered:

- Hardened AISI-440C (50–55  $R_c$ )
- Stellite or colmonoy-coated (hard-faced) austenitic stainless steel
- Solid stellite
- Tungsten carbide
- Silicon carbide
- Partially stabilized zirconia (PSZ)

Recent advances involving the use of ceramics, metal-matrix composite materials, laser-surface alloying, and laser-surface modifications to a substrate that normally could not survive in an abrasive service are examples of ongoing material developments.



**FIGURE 10** The three-body abrasive wear of a laser-hardened shaft sleeve in an abrasive service. Note the fine concentric scoring of the hardened surface. The helix pattern is the laser-beam overlapped zone produced by the laser process.

**Erosion** Most fluids handled by pumps are considered clear liquids, meaning they do not have significant amounts of solid particulates present. The corrosive nature of these fluids dictates the required pump materials. Guidelines for many of these services are embodied in “Corrosion in Pumps,” a tutorial published in the Ninth International Pump Users Symposium.<sup>4</sup>

However, many fluid-handling applications requiring pumps are far from clear liquids. Solid particulates can be removed with costly filtration systems that must work flawlessly at all times. Fabricated piping systems may introduce suspended solids from weld slag and pipe burn. Naturally occurring suspended solids are those found in water sources such as river water or seawater, as mentioned previously in the abrasive wear section.

The following factors should be considered during the material and pump selection phase of the procurement process:

- The hardness of the particles
- The quantity of particles
- Size distribution
- Nature (geometry)
- The velocity of the pumpage
- The angle of fluid impingement

The first four items listed deal with the suspended solids. These variables can vary from application to application. The hardness of the particles is important to understand in determining the materials necessary to yield an acceptable pump lifespan. Hardness can range from relatively soft substances, such as cellulose fiber in pulp and paper applications, to very hard abrasive particles such as silicon or rock in mining pumps. The Miller

number index, as described in ASTM G75,<sup>5</sup> is used to characterize the abrasivity of hard particles.

The Miller number was developed to determine the relative abrasivity and attrition of solid particles making up a slurry. In a closed loop test, the abrasivity of the particles becomes less damaging with time due to the fracturing and rounding (or friability) of the particles as they strike each other and/or impinge on a pump or casing wall.

The Miller number is therefore reported with two numbers. The first number characterizes the abrasivity of the particles and the second is the loss of abrasivity (attrition) of the particles during the slurry test. The abrasivity portion of the Miller number is useful in practical applications because this more closely characterizes a slurry's damaging potential. The attrition number has found little use other than characterizing a test loop's influence on a slurry. A slurry with a Miller number less than 50 is not considered abrasive in a reciprocating pump. Examples of slurries with a Miller number below 50 are limestone, sulfur, and detergent. It has been determined that a slurry consisting of finer particles is less abrasive than one containing larger particles. Test data shows that Corundum at 220 mesh is about four times as abrasive as the same material at 400 mesh.<sup>5</sup>

Particle velocity plays a major role in the degree of damage that occurs in a pump handling slurries. In this case, the potential energy is converted into kinetic energy, producing a material loss by the transfer of energy from the particle to the component. The amount of material damage on an individual particle scale depends specifically upon particle velocity,  $v$ , and mass,  $m$  (kinetic energy, defined as  $mv^2$ ). This is demonstrated by Finnie's equation<sup>6</sup> for hard materials:

$$\text{Wear rate} = (\# \text{ of impinging particles}) \times (\text{average particle mass}) \\ \times (\text{impingement velocity})^2 \times (\text{angle of impingement})$$

Of course, the pump part that absorbs the kinetic energy resulting from the particle impact has a role to play also. The material hardness and/or resilience of the pump component in absorbing the particle's impact energy will also determine the amount of material loss.

Chen and Hu<sup>7</sup> have performed laboratory tests on materials while changing the particle variables previously described. Their test results show the following:

- An increased particle hardness increases the material loss up to 1700-kg/mm<sup>2</sup> microhardness (greater than 75  $R_c$ ). Beyond this hardness, a decrease in wear occurs. This is most likely the result of the hard, brittle particle fracturing, which absorbs some of the kinetic energy.
- Sharp, angular particles increase the erosion rate over round particles.
- Erosion increases with increasing concentrations of abrasive particles.
- An increased fluid (and particle) velocity increases the erosion rate.
- Minimal erosion occurs at an impingement angle of 0° (tangent to the target surface) and increases to a maximum amount of wear at a 65° angle.

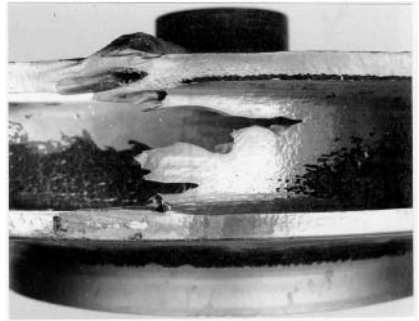
A review of the literature shows that several authors have plotted the solid particle impingement angle versus the amount of erosion.<sup>8,9</sup> These plots show that for ductile materials, erosion increases with the increasing impingement angle to a maximum material loss at an angle of 25°. Then the erosion damage decreases to the 65° impingement angle previously mentioned. Brittle materials, such as glass, are quite different. As the impingement angle increases from 0° to 90°, the volume of material loss continuously increases.

The characteristic features of erosion damage due to solid particle impingement are usually recognizable. However, when an aggressive fluid is present, the effects of solid particle impingement may not be easily identified. These effects can appear very much like corrosion-erosion, which is a fluid velocity-controlled damage mechanism where entrained solids are not present. If this damage is misdiagnosed, an improper material substitution can be made that may not solve the real problem. Conversely, a more likely situation is

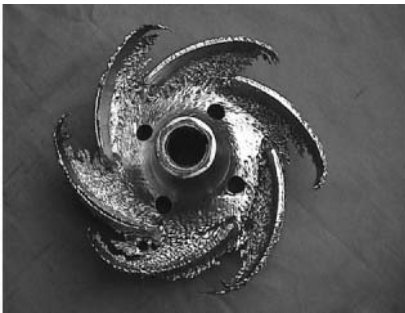




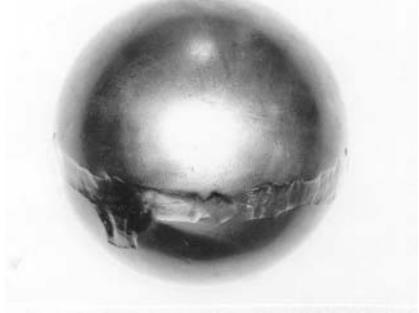
**FIGURE 11** The severe erosion of a carbon steel casing in a 17% bauxite and sand service. Note the gouging due to the local turbulence of the slurry.



**FIGURE 12** Erosion at the exit vane tips of a duplex, stainless steel CD4MCu impeller in a bauxite service.



**FIGURE 13** An austenitic stainless steel impeller in an abrasive fly ash service that shows severe erosion. Increased erosion occurs with an increasing fluid velocity near the periphery of the impeller.



**FIGURE 14** Erosion damage of an AISI-type, 440C stainless steel ball valve in a coal slurry service

that the observed damage resulting from the erosion-corrosion is misinterpreted as solid particle erosion. A full understanding of the pumpage including the fluid velocity, fluid corrosiveness, content, and nature of the solid particles present is necessary for the appropriate action to be taken in improving the life of a damaged pump.

An example of solid particle erosion in a pump is shown in Figures 11 and 12. The severe erosion damage of a casing is illustrated by the gouging of surfaces that were directly impinged or scoured by glancing blows of the solid particles in the fluid stream. This pump handles a bauxite slurry where the percentage and velocity of alumina ( $\text{Al}_2\text{O}_3$ ) and sand are too high for the carbon steel casing and CD4MCu impeller.

Figure 13 shows a CF3M impeller in a fly ash service. This shows that the greatest damage to the impeller is at the outer periphery, which corresponds to the highest velocity of the slurry. The least amount of damage is near the impeller inlet eye. Figure 13 also shows that the lower velocity region of the impeller inlet eye has the least damage. This confirms the laboratory data that shows an increased erosion with an increased slurry velocity. Note that the damage increases near the outside of the inlet eye and is almost nonexistent at the impeller hub where the fluid velocities are lower.

Erosion damage can also be encountered in reciprocating pumps. Figure 14 shows extensive erosion of an AISI-type, 440C stainless steel ball from a ball valve after it

became stuck and unable to rotate in a coal slurry application. This caused a slurry impingement on a concentrated region of the ball.

The particle velocity and impingement angle are design factors that can be used to mitigate erosion in pumps. The challenge in the coal liquefaction program investigated by the Department of Energy in the 1970s was to develop a high-speed pump for handling coal-oil slurries.<sup>8</sup> This was attempted because traditional slurry pumps are usually large, slow-moving machines that increased the capital and operating costs of pilot plants built during that era. Most of the slurry pump industry utilizes large, slow-moving, single-stage pumps to address the solid particle erosion problem. Many of these pumps are rubber-lined to absorb the particle's impingement energy.

Erosion damage, once identified, has a limited number of solutions to prolong the longevity of pump materials. This can be accomplished by the selection of hard, wear-resistant replaceable liners, elastomeric liners, or, in cases where liners cannot be utilized, hard materials. Such metallic materials include white cast iron (such as Ni-Hard), high chromium (13 to 28 percent) alloy steels, cobalt-based super alloys (such as Stellite), and nickel-based alloys.

## FATIGUE

---

Centrifugal and reciprocating pumps are subjected to cyclical loading, which, if not considered during design, will result in a limited life due to material fatigue. In combination with a corrosive environment, material fatigue can be accelerated due to what is commonly referred to as *environmentally assisted fatigue*.

The one essential parameter in component fatigue is the presence of an alternating or cyclic load. In general, pumps are machines that have either fluid or mechanically induced cyclic loading on their components. Although centrifugal pumps are for the most part steady-state rotational equipment, pulsations or fluctuating applied stresses are encountered. The source of these cyclic stresses can be from fluid interaction between impeller exit vanes and diffuser vanes or, in a volute pump, the impeller vanes and the casing cut-water. Mechanically induced forces are due to bending moments acting on the pump shaft or possibly a component imbalance in the rotor assembly. Reciprocating pumps experience a cyclic loading of the internal and external components from the action of the machinery. In fact, these pumps can be thought of as large fatigue-testing machines due to the pulsating action of the pumping process.

When cyclic forces are applied to materials in a pump over a period of time, a crack may initiate at the component's surface. After initiation, the crack will grow with continued cyclic loading until the part finally fractures. Fractures can occur, even though the loading produces stresses that are far less than the tensile strength of the material. Engineers have been aware of this potential mode of component fracture for many years and have developed design criteria that take this anomaly into account. The study of cyclic loading and material behavior based upon cyclic stress history and flaw size is beyond the scope of this text. It should be noted, however, that the field of fracture mechanics offers an engineering design tool that can predict the life of an engineered component.

Fatigue is a three-stage process consisting of (1) crack initiation, sometimes associated with preexisting defects, (2) crack propagation, and (3) the final fracture, associated with crack instability, as suggested by Wohler.<sup>10</sup> The applied stress level, sample geometry, flaw size, and mechanical properties determine the existence and extent of these stages.

Fatigue was first studied by August Wohler in 1852.<sup>11</sup> Wohler's work included the concept of alternating applied stress,  $S$ , and the number of cycles,  $N$ , applied to a sample until a fracture occurs. This work is the basis for today's  $S/N$  curves used by design engineers. A laboratory-generated  $S/N$  curve is shown in Figure 15. This curve was generated by smooth, rotating-beam test specimens. These specimens are machined carefully to avoid metallurgical notches on their surfaces that would lower the applied stresses required to produce a failure during testing.

When a corrosive media is introduced, many crack initiation sites are produced. The lower curve shows the resulting drop in the endurance limit. Since corrosion over time can



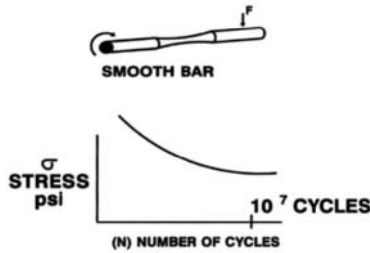


FIGURE 15 A laboratory-generated  $S/N$  curve for a smooth bar rotating beam test specimen

TABLE 2 Corrosion fatigue strength of alloys in sea water\*

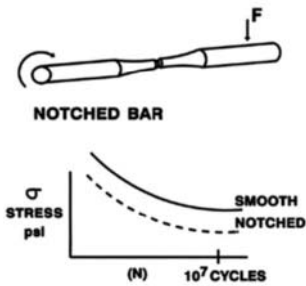
Alloy	UTS	CFS
Ti-6Al-4V	154	88
Inconel 718	189	60
Inconel 625	149	50
Hastelloy C	108	32
Monel alloy K-500	176	26
Ni Al bronze (cast)	115	15
304 Stainless	79	15
316 Stainless	85	14
304L Stainless	75	14
316L Stainless	79	13
17-4PH - cast		10
70-30 Cu-Ni (cast)	83	9
Ni Mn Bronze	82	9
Mn Bronze	73	8
D-2 Ni-Resist		7.5
Mild steel		2

\*Test parameters: ambient temperature, 1750 rpm, 2–3 ft/s (0.6–0.9 m/s). Corrosion fatigue strength (CFS) given at 100,000,000 cycles. All values are in ksi; 1 ksi = 6.894759 mPa. (UTS is ultimate tensile strength of material in air.)

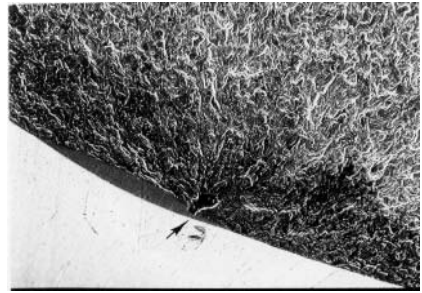
increasingly damage the material, the endurance limit will correspondingly decrease with the exposure time. No true fatigue limit exists for materials in a corrosive environment. For this reason, the corrosion-assisted fatigue life of a material is usually published with cautionary statements. Given enough time, corrosion can penetrate completely through a fatigue test specimen, resulting in a data point of zero load and zero cycles. For this reason, corrosion-influenced fatigue test results usually specify the corrosive media, the test temperature, the details of the sample pre-exposure to the corrosive media, and the test frequency with respect to the applied cyclic loading.

Published data varies because laboratories that use a low frequency of applied stresses increase the influence that corrosion has upon the test specimens. This is in comparison to laboratories that conduct these tests at a high frequency that minimizes the influence of the corrosive media. Published values for the ultimate tensile strength and corrosion fatigue strength of various alloys are shown in Table 2.<sup>12</sup>

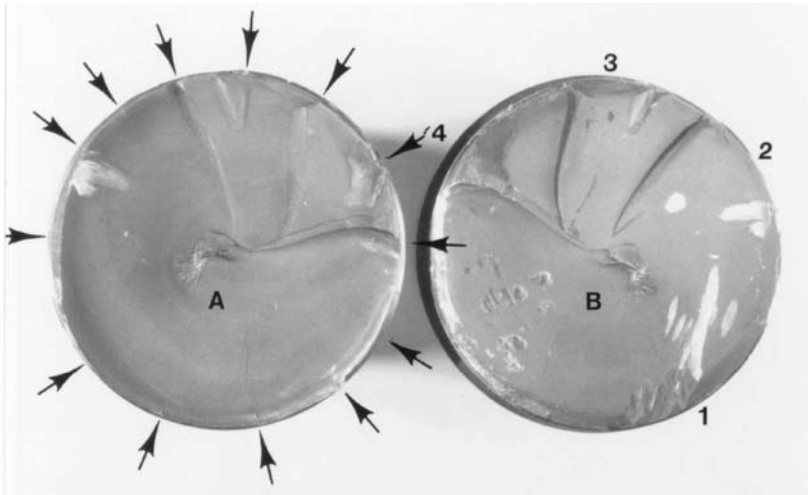
Wohler's investigation shows that a mechanical notch can reduce a material's fatigue.<sup>10</sup> This is shown in Figure 16 as a shift in the  $S/N$  curve below the curve produced by a smooth bar specimen. The severity of the notch determines the amount of divergence from the smooth bar curve. As shown, the surface degradation mechanisms lower the stress



**FIGURE 16** A shift in the  $S/N$  curve below the curve produced by a smooth bar specimen. The severity of the notch determines the amount of divergence from the smooth bar curve.



**FIGURE 17** SEM photo of a fracture smooth fatigue test specimen with a single origin. The arrow indicates the fatigue crack origin.



**FIGURE 18** Multiple origin fatigue fracture of a pump shaft. The arrows show the locations of the many fatigue crack origins. A and B correspond to the final fracture zone of each fracture face.

needed to produce the specimen failure after a certain number of cycles. This in turn reflects a lowering of the material's endurance limit.

The three stages of fatigue cracking can be observed on the fracture face, rendering them easily identifiable. This is especially true if no other secondary damage masks the characteristic appearance. Especially in fractures that occur over long periods, lines are visible on the fracture surface. These bands are sometimes referred to as *clamshell markings*, *crack arrest lines*, or *beach marks* and reflect different periods of crack growth. Ratchet lines, which represent the joining of two different crack fronts on different planes into one, are observed in multiple origin fatigue cracks. Multiple origin fatigue fractures are often associated with rotating components.

Figure 17 shows a high magnified view of a smooth bar fatigue specimen after a fracture. The arrow shows a single origin of this specimen. This fatigue crack propagated across the entire specimen diameter until the final fracture occurred, shown as a small circle. The final fracture is sometimes referred to as the *ductile overload zone* or the *fast fracture zone*.

An example of a fatigue fracture on a pump shaft is shown in Figure 18. The arrows in this figure indicate the location of many crack origins. The flat, smooth surface appearance

of this fracture face is characteristic of most fatigue fractures. This flat fracture appearance is sometimes mistaken for a brittle fracture because no evidence of plastic deformation is observed on or near the break. Shown almost directly in the center of the fractured shaft section is a small area of ductile overload, marked A and B, which corresponds to the final fracture area. The relatively small size of this area indicates the crack propagated under low alternating loads. In other words, the only material holding the two halves of the shaft together was the last area to fracture. This is a mere fraction of the total cross-sectional area of this shaft. The multiple arrows at the OD of the shaft shows the many crack origins. Fatigue ratchet marks are at each of these locations. This type of fatigue fracture is referred to as *multiple origin, high cycle fatigue*.

As mentioned before, an investigator uses the relative size of each fatigue crack stage to determine the magnitude of the loads acting on the component. The identification of the crack origin is also of prime concern in conducting a failure analysis. The crack origin is important to determine if the fatigue crack initiated from a flaw in the material or a notch produced in service or during manufacturing.

Corrosion, often the primary cause of pump material damage, can increase the likelihood of fatigue cracking. *Corrosion-assisted fatigue* is the name given to this special type of cracking. Corrosion damage can change the surface texture and significantly increase the local stresses acting on the pump component. If the corrosion damage is severe enough to produce a sharp notch in a region of high cyclic loading, then fatigue cracking of the component is inevitable. In some cases, the propagation phase is also influenced by oxidation, which can mask the telltale features of the fatigue mechanism. Corrosion oxides, which form along the crack face, can produce a wedging effect, which mechanically increases the local tensile forces acting on the crack tip. This increases the crack propagation rate.

An example of corrosion-assisted fatigue at two locations in the front shroud wall of an impeller is shown in Figures 19 and 20. The evidence of corrosion pitting on the surface indicates a strong possibility that corrosion influenced the fracture mode. Further investigation shows that both shroud wall fatigue fractures were initiated at corrosion pits located in highly stressed areas of the impeller. The fluid pulsations acting on the exit vane tip result in alternating loading.

Corrosion is not the only mechanism of surface degradation that can promote this form of cracking. Surface disruptions through fretting or wear can also provide sites for fatigue crack initiation. Sharp radii and defects at the material surface such as porosity and poor machining act as stress concentrations.

Once the mechanism of fatigue cracking has been identified, suitable corrective actions can be implemented. These include the following:



**FIGURE 19** Overall view of a CF-3M impeller that has two corrosion-assisted fatigue fractures in the front shroud wall



**FIGURE 20** A higher magnification of one of the fatigue fractures that originated at a corrosion pit at the exit vane tip and shroud intersection. Additional corrosion pitting can be seen on the impeller in this figure.

- **Higher strength materials** A good approximation for the endurance limit of a metal is 50% of the material's tensile strength. This is for high-cycle fatigue where no macro plastic loading is experienced. A graph published in *Deformation & Fracture of Engineering Materials*<sup>10</sup> shows this rule of thumb.
- **Design modification** The stress acting upon a component can be reduced with an increased section size. Reducing the stress on a component will increase its life. The design criteria for mean stress in an alternating loading environment can be determined using several analytical models. Since components are subjected to a range of loading (not a constant amplitude), a fluctuating mean stress is encountered. The anticipated load history can aid in the design process to avoid fatigue fractures. The prediction of potential component life can be based upon a fluctuating mean stress design criterion, referred to as the *Pamgren-Miner cumulative damage law*.<sup>10</sup>
- **Surface treatments** The introduction of compressive stresses to the surface of a part increases the fatigue life of a component. This is usually performed at crack-sensitive regions such as sharp corners or notches. If compressive stresses are introduced into the surface of a material, cyclic tensile stresses in excess of the compressive stress value are needed to cancel their effect before fatigue damage can occur. Therefore, any form of compressive stress will benefit a component with respect to fatigue cracking. Compressive stresses can be introduced by (1) cold working, (2) shot peening, or (3) a local heat treatment that introduces beneficial, compressive residual stresses (such as laser hardening or induction hardening).
- **Increased corrosion-resistant materials** The use of more highly corrosion-resistant materials is beneficial in cases where corrosion has decreased a component's life by degradation of its surface condition.

## MATERIALS OF CONSTRUCTION

---

**Impellers** The pump designer needs to consider several criteria when selecting the material for the impeller:

- Corrosion resistance
- Abrasive wear resistance
- Cavitation resistance
- Casting and machining properties
- Weldability (for repair)
- Cost

For many water and other noncorrosive services, bronze satisfies these criteria and, as a result, is the most widely used impeller material for these services. Bronze impellers should not be used for pumping temperatures in excess of 250°F (120°C). This is a limitation imposed primarily because of the differential rate of expansion between the bronze impeller and the steel shaft. Above 250°F (120°C), the differential rate of expansion between bronze and steel will produce an unacceptable clearance between the impeller and the shaft. The result will be a loose impeller on the shaft.

Leaded bronzes have been used extensively in the past as impellers, especially in less demanding applications. The lead addition to bronze enhances its castability and machinability. In recent years, environmental concerns associated with lead have caused many nonferrous foundries to stop producing these alloys and pump manufacturers are increasing their use of nonleaded bronzes for impeller applications.

It should be noted that bronzes have velocity limitations above which they will suffer accelerated erosion corrosion. The maximum velocity, which will correspond with the periphery of the impeller, is higher in fresh water than in salt water. The most resistant bronzes, able to tolerate the highest velocities, are the nickel aluminum bronzes. These

alloys are often used as impellers in salt water applications because they combine high mechanical properties, good corrosion resistance, and the capability to be weld-repaired. A nickel aluminum bronze impeller can be designed for a higher speed than any other bronze impeller alloy.

Cast-iron impellers are used to a limited extent in small, low-cost pumps. Cast iron is inferior to bronze in corrosion, erosion, and cavitation resistance. It also cannot be welded to repair damage due to wear or erosion. For these reasons, a low initial cost is usually the only justification for selecting a cast-iron impeller.

Martensitic stainless steel impellers are widely used where bronze will not satisfy the requirements for corrosion, erosion, or cavitation resistance. The alloys most commonly used are CA-15 and CA-6NM. These alloys can be used for pumping temperatures above 250°F (120°C), as the differential expansion problem no longer exists with a steel impeller on a steel shaft. Martensitic stainless steel impellers are used in a wide range of applications, including boiler feed water, many cooling waters, and a variety of hydrocarbon applications. It does not have sufficient resistance to pitting corrosion for use in sea water.

Martensitic stainless steels are heat-treatable alloys. The specified mechanical properties are developed through a quench and temper heat treatment. Quenching can be in oil or, as is more common, in air. The cooling rate in air is sufficiently rapid that the high temperature austenitic structure will transform to the metastable martensitic structure, which can subsequently be tempered to the desired hardness. The designer should specify that tempering be done at a minimum temperature of 1100°F (600°C) in order to assure that the casting has adequate toughness. It is also important that these alloys be heat-treated after weld repairs. This can present a problem in the case of a finish machined casting, which would suffer distortion if heat-treated. Welding techniques have been developed, however, that do not require a post-weld heat treatment, but these are, in most cases, unsuitable for use on martensitic stainless impellers.

Oil and refining industry applications often involve exposure to hydrogen sulfide, which may be present as a trace contaminant in hydrocarbon fluids. Martensitic stainless steels are susceptible to a form of SCC in this environment and should be specified with a special double-temper heat treatment designed to limit hardness and thereby prevent cracking.

Austenitic stainless steels are used for impellers in applications requiring a higher level of corrosion resistance than can be obtained from the martensitic grades. A number of different alloys make up this group. The most widely used are CF-8M and CF-3M, which are the cast versions of the well-known 316 and 316L wrought materials. The cast alloys have a slightly different chemistry than the wrought grades. This difference accounts for the presence of 5 to 15% ferrite in the castings, which makes them slightly magnetic. The ferrite also enhances the resistance to SCC and hot shortness, a casting problem associated with fully austenitic cast grades. These alloys provide corrosion resistance over a wide range of pH and have reasonably good resistance to pitting and crevice corrosion in aqueous chlorides.

Higher alloyed austenitic cast grades are also available for applications requiring a greater degree of corrosion resistance. Alloy 20 contains about 30% nickel and was developed for sulfuric acid applications. The high nickel makes the alloy fully austenitic (without ferrite). Consequently, it is difficult to cast and suffers from hot shortness, which may manifest itself as fine cracking at the intersection between the vane and the shroud in an impeller. The high nickel content also makes Alloy 20 very resistant to SCC.

Austenitic grades containing 6% molybdenum have been developed for use in salt water and other high-chloride applications such as acidic brines used in oil field waterflood injection. The high level of molybdenum makes these alloys fully resistant to pitting in stagnant seawater, which will be present when a pump is not in operation. The 6% molybdenum grades are more expensive and therefore not frequently used for most applications. These alloys are usually considered only for critical, demanding applications where a high level of corrosion resistance is needed.

Austenitic stainless steels with unique properties have been developed for specific applications. A chrome-manganese alloy, discussed in the section on cavitation erosion, can be employed to mitigate or entirely eliminate cavitation damage in problem applications.

A high-strength austenitic stainless grade, CF10SMnN, can be used where the mechanical properties of CF-8M are inadequate. Some pump manufacturers also offer nitrogen-enriched austenitic grades that have corrosion resistance and mechanical properties better than CF-8M.

Duplex stainless steels offer a combination of higher mechanical properties and better corrosion resistance than the standard austenitic grades. The original duplex casting grade, CD4MCu, was developed in the 1950s. Use of this material was limited by problems with castability and weldability. Improved steelmaking technologies now enable the addition of precise amounts of nitrogen to duplex stainless steel. The nitrogen addition improves castability, weldability, and also corrosion resistance. Numerous duplex stainless grades have been developed in recent years, all having a specified nitrogen addition. These duplex grades all outperform the old CD4MCu grade, which did not have a nitrogen addition. Many foundries now make CD4MCu with nitrogen.

Duplex stainless impellers are extensively used in mining, flue gas desulfurization, and similar applications that require a combination of resistance to corrosion and abrasion. Duplex stainless steels also have better corrosion resistance than the standard austenitic grades and are used in a variety of applications in the chemical industry, the pulp and paper industry, and the marine industry. Duplex stainless pumps are standard for offshore high-pressure water injection pumps in the oil industry. Published corrosion data indicates that, for acceptable resistance to seawater, a duplex stainless should contain a minimum of 25% chrome, 3% molybdenum, and 0.15% nitrogen.

**Casings** The following criteria should be considered when selecting material for centrifugal pump casings:

- Strength
- Corrosion resistance
- Abrasive-wear resistance
- Casting and machining properties
- Weldability (for repair)
- Cost

For many pumping applications, cast iron is the preferred material for pump casings when evaluated on the basis of cost. For single-stage pumps, cast iron usually has sufficient strength for the pressures developed. For corrosive or hazardous petroleum products, it may be necessary to specify cast steel or cast stainless steel. The concern with cast iron when handling hazardous fluids is that the material is inherently brittle and could fail suddenly in a catastrophic manner with no prior indication of distress.

Cast-iron casings for multistage pumps are limited to approximately 1000 lb/in<sup>2</sup> (6.9 MPa) discharge pressure and 350°F (177°C). For temperatures above 350°F (177°C) and pressures up to 2000 lb/in<sup>2</sup> (13.8 MPa) discharge pressure, a cast steel is usually specified for split-case, multi-stage pumps. For pressures higher than 2000 lb/in<sup>2</sup> (13.8 MPa), a cast or forged steel barrel-type casing is usually required.

In any evaluation of cast iron versus steel casings, consideration should be given to the problem of casing erosion during operation. Erosion can occur either from abrasive particles in the fluid or from wire drawing across the flange of a split-case pump. Although the initial cost of a steel casing is higher than that of a cast-iron casing, a steel casing can often be salvaged by welding the eroded portions and remachining. Salvaging a cast-iron casing by welding is much more difficult, and the casting usually must be replaced.

The ductile irons are useful casing materials for pressure and temperature ratings between cast irons and steels. Although the modulus of elasticity for the ductile irons is essentially the same as that for cast iron, the tensile strength of the former is approximately double that of the latter. In any evaluation of the ductile irons as a substitute for the steels in the intermediate pressure and temperature range, it should be remembered that ductile iron casings cannot be effectively repair-welded.



Austenitic irons, commonly known by the tradename *Ni-Resist*, are used for pump casings in applications where gray and ductile irons have insufficient corrosion resistance. Austenitic irons typically contain 15 to 20% nickel. They are frequently used in brackish and salt water applications where they are considerably more resistant to both corrosion and erosion than unalloyed gray iron. A preferred combination for this service is a Ni-Resist casing and stainless internals. The stainless steel is galvanically protected from pitting when the pump is made idle by the more anodic Ni-Resist casing.

The traditional Ni-Resist alloys have poor weldability in common with other types of cast iron. In recent years, a new and more readily weldable Ni-Resist grade has been developed. This grade, designated *D2W*, contains a small columbium addition that enhances weldability. This new D2W grade is gaining popularity as the preferred grade for pump casings.

Bronzes are also used for pump casings in many water applications. Several bronzes are used, with the choice depending upon the specific application. Leaded bronzes, specifically leaded red brass, are used for small low-pressure pumps. This material is the least costly and easiest to cast of the bronzes. Tin bronzes, with or without lead, are used for larger centrifugal pump casings. The lead contributes to the pressure tightness of the casting. Unleaded bronzes often have to be impregnated in order to obtain adequate pressure tightness. Unleaded tin bronze can be weld-repaired, whereas the leaded version is not weldable. Nickel aluminum bronze has the highest mechanical properties and the best corrosion resistance of the bronze alloys normally considered for pump casings. It can also be repaired by welding. Nickel aluminum bronze casings are expensive and usually not competitive on a cost basis with NiResist or other alternatives.

Stainless steels are selected for pump casings when required due to corrosion considerations. Martensitic stainless steels are commonly used to handle boiler feed waters as well as many hydrocarbon applications. These materials have good mechanical properties and are suited for high-pressure applications. Their corrosion resistance is less than that of other categories of stainless steel and for this reason, they are unsuited for more aggressive waters or other fluids.

The austenitic stainless steels, particularly CF-8M and CF-3M, are frequently used for pump casings in chemical applications and other corrosive services. These materials can handle a wide range of pH. They are resistant to erosions by high velocity and can be field-weld-repaired with relative ease.

Duplex stainless steels (stainless steels having a metallurgical structure that is approximately 50 percent ferrite and 50 percent austenite) are used for pump casings in some applications that require a combination of corrosion resistance and mechanical properties superior to that of the standard austenitic grades. These materials have become the preferred choice for high-pressure, offshore injection pumps handling sea water. The higher mechanical properties permit the design of thinner wall, lighter pumps. The weight savings is an important factor in this application.

**Shafts** The following criteria should be considered in the selection of material for a centrifugal pump shaft:

- Endurance limit
- Corrosion resistance
- Notch sensitivity

The endurance limit is the stress below which the shaft will withstand an infinite number of stress reversals without failure. Since one stress reversal occurs for each revolution of the shaft, this means that ideally the shaft will never fail if the maximum bending stress in the shaft is less than the endurance limit of the shaft material.

In practice, however, the endurance limit is substantially reduced because of corrosion and stress raisers, such as threads, keyways, and shoulders on the shaft. In selecting the shaft material, consideration must be given to the corrosion resistance of the material being pumped as well as to its notch sensitivity. Corrosion will substantially lower the fatigue limit of the material. Fatigue cracks will initiate at corrosion pits or other surface discontinuities that act as stress risers.

In the absence of corrosion, an approximate relationship exist between fatigue endurance limits and mechanical properties. The endurance limit is equal to roughly half the tensile strength of the material. Depending upon the application, the pump designer will usually select the least expensive shaft material that will satisfy the three criteria noted previously. Carbon steel is used when corrosion resistance is not required, and relative low mechanical properties can be tolerated. A low alloy steel, often AISI 4140, is used when the mechanical properties of carbon steel are not adequate. Martensitic stainless steels, usually type 410, are a common choice when some measure of corrosion resistance, combined with reasonably good mechanical properties, is required. The resistance of type 410 stainless to fatigue crack initiation is related to the toughness of the material, which can vary over a wide range in commercial bar stock. The best measure of material toughness is the Charpy impact test, which is not a requirement of most relevant material specifications. In order to ensure the optimum toughness and resistance to fatigue cracking, type 410 stainless should be tempered at a temperature of 1100°F (593°C) minimum.

Stainless steels offering improved corrosion resistance and mechanical properties are also used in pump shafting. These include Nitronic 50, an austenitic grade, and 17-4PH, a precipitation hardening grade.

Several manufacturing issues related to the creation of pump shafts also need to be considered. Difficulty has frequently been experienced when maintaining the stringent tolerances for straightness required for long, thin shafts that are used in multi-stage pumps. This may necessitate intermediate stress relief during the machining process. The shaft may be stress-relieved in the vertical position or, if horizontal, with supports every few feet. Type 410 pump shafting can be specially heat-treated to eliminate residual stress and maintain straightness tolerances during pump operation.

Shafts can be plated or coated in specific areas for an improved resistance to wear or corrosion. Chrome plating is commonly used in this manner. The designer needs to be aware that plating reduces the fatigue endurance limit because of the fine micro-cracking associated with this process. An improvement in fatigue life can be achieved on plated surfaces if the substrate is shot peened. Normally, this reduction in endurance limits is not critical, because it is the flat surfaces, rather than the shoulders or keyways, that are being plated. Consequently, the largest stress raisers are elsewhere in the shaft. There is also the potential for the plating process to cause hydrogen embrittlement cracks in high-strength steels. To avoid this problem, the steel should be baked at 300 to 400°F (150 to 200°C) after the plating process.

Finally, the manufacturing process needs to be carefully controlled to avoid the inadvertent introduction of stress raisers, which could shorten the life of the shaft. Abusive grinding has been identified as the root cause of some shaft fatigue failures. Heavy grinding will heat the surface and cause hardenable steels to form a thin layer of untempered martensite. This is a brittle structure and likely to develop fine cracks. These are stress raisers that can be propagated by a fatigue mechanism once the pump is placed in service. This type of problem is avoided by proper controls on the manufacturing process.

**Wear Rings** The following criteria should be considered in the selection of the material for the wear rings:

- Corrosion resistance
- Abrasive wear resistance
- Galling characteristics
- Casting and machining properties
- Suitability for coating

A centrifugal pump will often have both case and impeller wear rings. The impeller wear ring rotates within the bore of the stationary or case wear ring. These rings provide a close running clearance to minimize leakage from the discharge to the suction of the impeller. As the rings wear with use, leakage will gradually increase, affecting the head, capacity, and efficiency of the pump. In multistage (flexible rotor) pumps, increased wear ring clearance may also affect rotor stiffness.



To reduce the rate of wear of the wear rings, and thereby increase the life of the pump, special considerations must be given to the corrosion and abrasive wear characteristics of the ring material. Since the impeller and case rings may occasionally touch one another, the combination should also be selected to have anti-galling characteristics.

Bronze is a widely used material for wear rings because it exhibits good corrosion resistance for a wide range of water services. In addition, bronze exhibits good wear characteristics in clear liquids but tends to wear rapidly when abrasive particles are present. The bronzes also have a relatively good resistance to galling. The leaded bronzes offer excellent galling resistance but use of these grades has been reduced due to environmental concerns associated with lead. The casting and machining properties of most grades of bronze are excellent.

In applications where bronze is not suitable because of either corrosion or abrasive wear limitations, or where pumping temperatures exceed 250°F (120°C), stainless steel rings are used. Unlike bronze, the stainless steels of the 300 and 400 series have poor galling resistance. Several options are available to minimize the possibility of galling between stainless steel rings. The clearance between the rings can be increased, serrations can be machined into one of the rings, or a minimum hardness differential of 50 to 100 Brinell points can be established between the rings, if made from a hardenable grade of stainless, such as the martensitic grades. If both rings are hardened to above 400 BHN, it is not necessary to maintain a hardness differential.

Martensitic stainless steel rings are usually hardened in a furnace. A laser hardening process is also available that involves heating only the surface of the material, which is rapidly quenched by the base metal, resulting in a precisely controlled surface hardness and a soft ductile core. Rings hardened in this manner are more resistant to cracking in some environments and provide increased wear resistance because of increased surface hardness (50-55  $R_c$ ). A summary of adhesive wear test results can be found in Table 3.

Increasing the clearance between rings is the least costly method for reducing the risk of galling or seizures. However, increasing the clearance will reduce the output and efficiency of the pump. In large, low-head pumps, the loss in efficiency is less than one percent, but in small, high-head pumps, the loss in efficiency can be significant. Serrated rings

**TABLE 3** Calculated wear factor

Material (Ring/Block)	Hardness DPH (Ring/Block)	Wear Factor K
In Distilled Water Specific Gravity 1.0		
Leaded Bronze/ASTM A48 Class 30 CI	80/205	$0.17 \times 10^{-4}$
Ni-Resist/Ni-Resist	120/120	$0.41 \times 10^{-4}$
Nitronic 50/Nitronic 60	195/190	$0.76 \times 10^{-4}$
90-10 CuNi/ASTM A48 Class 30	87/210	$1.14 \times 10^{-4}$
Stellite 12/Stellite 6	440/395	$1.71 \times 10^{-4}$
Ampco 18/Ampco 18	155/155	$2.40 \times 10^{-4}$
AISI 410/ASTM A743-CA6NM	300/270	$2.45 \times 10^{-4}$
AISI 410/AISI 416	290/430	$2.97 \times 10^{-4}$
AISI 416/AISI 416	430/360	$3.57 \times 10^{-4}$
In Alcohol Specific Gravity 0.87		
Nitronic 50/Nitronic 60	195/190	$0.62 \times 10^{-4}$
Leaded Bronze/ASTM A48 Class 30	80/205	$1.54 \times 10^{-4}$
AISI 410/AISI 416	290/430	$7.38 \times 10^{-4}$
In Iso-octane Specific Gravity 0.69		
Leaded Bronze/ASTM A48 Class 30 CI	80/205	$0.41 \times 10^{-4}$
Nitronic 50/Nitronic 60	195/190	$0.69 \times 10^{-4}$

can be used on smaller pumps to help maintain the efficiency level, but only at an increase in manufacturing costs.

For cast-iron, bronze, hardened 11- to 13% chromium steels, and materials with similar low-galling tendencies, the recommended minimum running clearances between rings are given in API Standard 610, "Centrifugal Pumps for Petroleum, Heavy Duty Chemical, and Gas Industry Services." For materials with higher galling tendencies, such as austenitic stainless steels and for all materials operating at temperatures above 500°F (260°C), it is suggested that 0.005 in (0.125 mm) be added to the recommended minimum diametrical clearances.

Several anti-galling material combinations have been used that do not compromise either wear or corrosion resistance. Nitronic 60 is a nonstandard austenitic grade that contains both manganese and nitrogen. This alloy has been developed for antigalling characteristics and will resist galling when mated with standard 300-series grades, Nitronic 50, and other alloys having poor galling resistance. Nitronic 60 is available in both wrought and cast forms. A cast nickel base alloy, Waukesha 88, offers equally good antigalling characteristics and can be used in brine and other corrosive environments. A summary of galling thresholds for commonly used material combinations is shown in Tables 4 and 5.

Colmonoy- or Stellite-coated rings are used in some critical applications and provide a high degree of resistance to abrasive wear, corrosion, and galling. These coatings are applied by welding, which can produce unacceptable distortion in rings, especially in larger diameters. The pump designer needs to exercise caution in specifying rings having a weld overlay because of potential manufacturing problems, which can involve cracking of the weld overlay or distortion of the ring. Some large rings for sewage pumps have performed well with tungsten carbide coatings applied using a high-velocity plasma spray process. The advantage of this process is that it does not heat the substrate, thereby avoiding distortion. Tungsten carbide is used for its high hardness and resistance to abrasion.

## SELECTION OF MATERIALS OF CONSTRUCTION

The selection of materials for pumps is often not a simple and straightforward matter because of the weight assigned to various technical and economic factors by different

**TABLE 4** Galling resistance of alloys

Metals in Contact			Threshold Galling Stress (ksi)	Threshold Galling Stress (mPa)	
Silicon Bronze	BHN 200	vs. Silicon Bronze	BHN 200	4	27.6
Silicon Bronze	BHN 200	vs. Type 304	BHN 140	44	303
Waukesha 88	BHN 141	vs. Type 303	BHN 180	50+	345+
Waukesha 88	BHN 141	vs. Type 316	BHN 200	50+	345+
Waukesha 88	BHN 141	vs. S17400	BHN 405	50+	345+
Type 410	BHN 322	vs. Type 420	BHN 472	3	20.7
Type 416	BHN 342	vs. Type 316	BHN 372	13	89.6
Type 416	BHN 372	vs. Type 410	BHN 322	4	27.6
Type 440C	BHN 560	vs. Type 440C	BHN 604	11	75.8
S17400	BHN 311	vs. Type 304	BHN 140	2	13.8
S17400	BHN 435	vs. Type 304	BHN 140	2	13.8
Nitronic 50	BHN 205	vs. Nitronic 50	BHN 205	2	13.8
Nitronic 60	BHN 213	vs. S17400	BHN 313	50+	345+
Nitronic 60	BHN 205	vs. Nitronic 50	BHN 205	50+	345+
Nitronic 60	BHN 205	vs. Stellite 6B	BHN 415	50+	345+

**TABLE 5** Galling resistance of alloys

Metals in Contact				Threshold Galling Stress (ksi)
Class 30 Cast Iron	(BHN 159-172)	vs. UNS C93200—Leaded Tin Bronze	(RB 41-43)	14.3
ASTM A487 CA6NM	(RC 29-31)	vs. Type 416	(BHN 352-415)	5.9
ASTM A487 CA6NM	(RC 29-31)	vs. Type 410	(BHN 353-415)	2.1
ASTM A487 CA6NM	(RC 29-31)	vs. Type 420—Laser Hardened	(RC 53-55)	1.7
Laser hardened Type 420	(RC 50-51)	vs. Type 420—Laser Hardened	(RC 53-55)	15.9
Type 420	(RC 50-55)	vs. Type 420	(RC 50-55)	21.1
Type 420	(RC 48-49)	vs. As-received nodular iron	(RC 24-26)	2.5
Type 420	(RC 48-49)	vs. Nitrided nodular iron	(RC 45)	10.9
Type 420	(RC 48-49)	vs. Laser glazed nodular iron	(RC 57-60)	11.3
Type 420	(RC 48-49)	vs. Laser hardened nodular iron	(RC 57-60)	6.8
Type 420	(RC 48-49)	vs. CA15	(RC 44-45)	1.8
Type 420	(RC 48-49)	vs. Zirconia	(R45N 74-79)	25*
Type 420	(RC 48-49)	vs. TDC on AISI 4140	(RC 70-80)	5.1
Type 420	(RC 48-49)	vs. Electroless nickel on nodular iron	(RC 45-49)	5.1
Type 420	(RC 48-49)	vs. Graphalloy bronze	(45-50 Schleroscope)	4.3
Type 420F	(BHN 262-302)	vs. Type 420F	(RC 50-55)	3.8
Type 410	(BHN 262-302)	vs. Type 410	(BHN 353-415)	1.2
Type 416	(BHN 262-302)	vs. Type 416	(BHN 352-415)	2.7
Nodular iron	(RC 27)	vs. Graphalloy bronze	(45-50 Schleroscope)	3.6
Nodular iron	(RC 27)	vs. Graphalloy nickel	(45-50 Schleroscope)	
Nitrided nodular iron	(RC 45)	vs. Graphalloy bronze	(45-50 Schleroscope)	2.0
Nitrided nodular iron	(RC 45)	vs. Graphalloy nickel	(45-50 Schleroscope)	3.6
Laser glazed nodular iron	(RC 57-60)	vs. Graphalloy bronze	(45-50 Schleroscope)	3.6
Laser glazed nodular iron	(RC 57-60)	vs. Graphalloy nickel	(45-50 Schleroscope)	3.6
Laser hardened nodular iron	(RC 57-60)	vs. Graphalloy bronze	(45-50 Schleroscope)	5.0

(continues)

**Table 5** Continued.

Metals in Contact				Threshold Galling Stress (ksi)
Laser hardened nodular iron	(RC 57-60)	vs. Graphalloy nickel	(45-50 Schleroscope)	7.0
CA15	(RC 44-45)	vs. Graphalloy bronze	(45-50 Schleroscope)	2.0
CA15	(RC 44-45)	vs. Graphalloy nickel	(45-50 Schleroscope)	3.6
TDC on AISI 4140	(RC 70-80)	vs. Graphalloy bronze	(45-50 Schleroscope)	3.8
Electroless nickel on nodular iron	(RC 45-49)	vs. Graphalloy bronze	(45-50 Schleroscope)	2.5
Graphalloy bronze	(45-50 Schleroscope)	vs. Graphalloy bronze	(45-50 Schleroscope)	3.6**
TDC on AISI 4140	(RC 70-80)	vs. Graphalloy nickel	(45-50 Schleroscope)	5.0
Electroless nickel on nodular iron	(RC 45-49)	vs. Graphalloy nickel	(45-50 Schleroscope)	3.8
Graphalloy bronze	(45-50 Schleroscope)	vs. Graphalloy nickel	(45-50 Schleroscope)	3.6**
Nodular iron	(RC 24-26)	vs. Zirconia	(R45N 74-79)	12.7*
Nitrided nodular iron	(RC 45)	vs. Zirconia	(R45N 74-79)	14.0
Laser glazed nodular iron	(RC 57-60)	vs. Zirconia	(R45N 74-79)	25.5*
Laser hardened nodular iron	(RC 57-60)	vs. Zirconia	(R45N 74-79)	25.5*
CA15	(RC 44-45)	vs. Zirconia	(R45N 74-79)	15.3*
Nodular iron	(RC 24-26)	vs. TDC on AISI 4140	(RC 70-80)	1.8
Nitrided nodular iron	(RC 45)	vs. TDC on AISI 4140	(RC 70-80)	11.5
Laser glazed nodular iron	(RC 57-60)	vs. TDC on AISI 4140	(RC 70-80)	15.3***
Laser hardened nodular iron	(RC 57-60)	vs. TDC on AISI 4140	(RC 70-80)	20*
CA15	(RC 44-45)	vs. TDC on AISI 4140	(RC 70-80)	5.1
Nodular iron	(RC 24-26)	vs. Electroless nickel on nodular iron	(RC 45-49)	3.8
Nitrided nodular iron	(RC 45)	vs. Electroless nickel on nodular iron	(RC 45-49)	2.5
Laser glazed nodular iron	(RC 57-60)	vs. Electroless nickel on nodular iron	(RC 45-49)	5.1
Laser hardened nodular iron	(RC 57-60)	vs. Electroless nickel on nodular iron	(RC 45-49)	5.1
CA15	(RC 44-45)	vs. Electroless nickel on nodular iron	(RC 45-49)	5.1

\* No galling at this stress. Testing is limited by torque capabilities.

\*\* No severe damage

\*\*\* Inconsistent results

Note: All stress values in ksi (1 ksi = 6.894759 mPa)

users. A final selection may involve a compromise between the manufacturing cost and the anticipated maintenance costs. This is particularly true for fluids like sea water, for which a wide range of materials have been used, from cast iron pumps with bronze internals to 6% molybdenum austenitic stainless steels. Despite the fact that economic factors unique to a particular application may influence the choice of materials for that application, some general guidelines can be used for some of the more common fluids.

**Boiler Feed Water/Condensate** High purity water at a high temperature can be very corrosive to cast iron and carbon steel despite the fact that it usually has a low oxygen content. These materials will suffer erosion corrosion, sometimes within months, if incorrectly applied. High purity water is defined as that having a conductivity of 20 micromhos/cm or less, which is equal to a dissolved solids content of 10 ppm or less. At these low levels, carbon steel and cast iron are incapable of developing surface films such as magnetite that minimize erosion corrosion. The precise mechanism is not well defined, but the relationships between conductivity, oxygen content, pH, temperature, and the influence of these variables on erosion corrosion were established by pioneering work conducted at the Detroit Edison Power Plants in the 1950s.

The purity of feedwaters has increased over the years as water treatments have become more effective in removing dissolved solids to meet the demands of modern boilers. As a consequence, these waters have also become more corrosive. The early work at Detroit Edison showed that chromium additions to carbon steel dramatically enhance the resistance to erosion corrosion in high purity water. Chrome additions of 1–1.25% are sufficient in most boiler feedwaters to impart acceptable corrosion resistance. Pump manufacturers initially used 5% chromium alloy steels for these applications. Difficulties in casting and welding five-percent chromium steels led to the more recent use of 12–13% chrome steels, notably CA-15 and CA-6NM. These are now commonly used in boiler feed pumps, condensate pumps, and others that handle high purity waters.

Water purity is often reported in the fluid's conductivity. Units of micromhos or microsiemens are used for this purpose. It has been determined that for high-temperature, boiler feed water services greater than 200°F (greater than 93°C), care in selecting materials is important for ultra pure waters. For waters greater than 200°F (93°C) with a conductivity less than 20  $\mu$ mho and alloys with greater than 3% chrome, an addition is required to avoid corrosion erosion at high-velocity areas. Figure 21 shows a carbon steel shaft that was severely damaged in ultra pure water. The proper selection of materials can be achieved by using Figure 22 as a guideline.

Some applications still remain in which cast iron, bronze, and other less costly materials can be used. Materials are selected based on water chemistry, which is divided specifically into four parameters: pH, temperature, conductivity, and dissolved oxygen. Table 6



**FIGURE 21** The corrosion erosion of a carbon steel shaft that was damaged in an ultra-pure water service after approximately six months

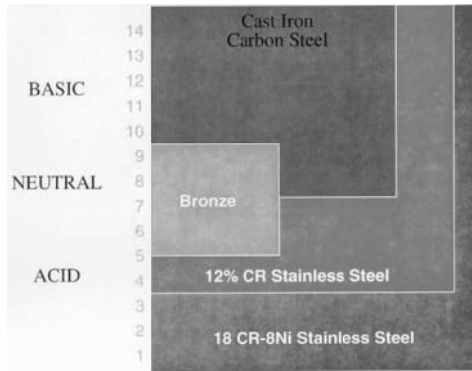


FIGURE 22 A graph indicating the proper materials selection in specific pH ranges for boiler feed services

TABLE 6 Materials for Boiler Feed Water Services

pH range	Feedwater Parameters				
	0–14	4.5–14	6–9	6–14	9–14
Temperature ≤ 200°F (93°C)	S	G-S	B*-J* H-G-S	H-G-S	C*-L*-DR* H-G-S
Temperature > 200°F (93°C) Conductivity < 20 μmho/cm Dissolved Oxygen > 0.04 ppm	S	G-S			
Temperature > 200°F (93°C) Conductivity < 20 μmho/cm Dissolved Oxygen < 0.04 ppm	S	G-S		NM-G-S	
Temperature > 200°F (93°C) Conductivity > 20 μmho/cm Dissolved Oxygen < 0.04 ppm	S	G-S	B*-J* H-G-S	H-G-S	C*-L*-DR*

\* Head must be less than 600 ft/stage (180 m/stage)

Materials:

B—Cast iron casing—bronze impeller—cast iron/bronze rings

C—All cast iron

DR—Carbon steel casing—cast iron impellers

G—All 12% chrome (CA-15 or CA-6NM)

H—Carbon steel case—12% chrome impellers (CA-15 or CA-6NM)

J—Cast iron case—bronze impellers—bronze rings

L—All cast iron with 12% chrome rings

NM—1- or 2-chrome barrels—12% chrome impeller (CA-15 or CA-6NM)

S—All 316 stainless (CF-3M)

represents an industry consensus on the recommended materials choices for the full range of high purity waters.

**Saline Water** Saline waters have been defined as those that are sufficiently electrically conductive to enable an appropriate pump casing material to galvanically protect the pump internals when the pump is shut down. This corresponds to waters with more than

about 1000 ppm chloride. Many pump applications involve saline waters. Among the more common saline water applications are the following:

- **Tidal river water** The chloride level here can fluctuate significantly with the season and the ingress of salt water from a bay or estuary.
- **Groundwater** The chloride level and corrosivity can vary over a wide range. Some groundwaters, which are injected by high-pressure pumps into oil formations to enhance output, are very corrosive, due to low pH and very high chloride levels.
- **Geothermal water** This type may contain high levels of hydrogen sulfide, carbon dioxide, and other gases in addition to chlorides.
- **Oilfield brines** These are often deaerated, greatly reducing their corrosivity. Less corrosion-resistant pump materials may be used but are susceptible to corrosion during shutdown periods when oxygen cannot be effectively excluded from the water.
- **Sea water** The chemical composition of seawater is relatively uniform throughout the world. Other factors, including temperature, microbiological activity, and the presence of pollutants can alter the corrosivity of the seawater to pump materials of construction.

For each of the saline waters, a variety of materials has been used for pumps. The choice of materials for a particular application will depend on the water chemistry and other factors including the expected life of the pump, whether it will operate continuously or sit idle for long periods, and user preferences based on previous experiences. Some general considerations will influence material selections.

The materials for saline water pumps must resist erosion corrosion. Ni-Resist and copper base alloys are frequently specified but have velocity limits, above which the protective oxide film is stripped off and accelerated corrosion occurs. Among copper base alloys, nickel aluminum bronze can tolerate the highest velocity. The pump designer needs to be aware of these limitations and use bronze and Ni-Resist only for components when the velocity limits of the materials will not be exceeded.

Stainless steels develop a more tenacious oxide film than bronzes and can tolerate velocities much higher than those seen in pumps without suffering erosion corrosion. However, stainless steels are susceptible to pitting and crevice corrosion in stagnant seawater. These problems are exacerbated if marine biofouling occurs. Several methods exist for handling this problem. The stainless internals of a pump can be effectively protected by galvanic coupling with Ni-Resist. The combination of a Ni-Resist case and stainless steel internals is widely used because of this favorable galvanic relationship.

To avoid localized corrosion during shutdown in an all-stainless pump, some form of cathodic protection is required. This can be either sacrificial anodes or an impressed current system. It is also possible to construct the pump of stainless grades that are highly alloyed and develop adequate corrosion resistance. This approach requires either 6% molybdenum austenitic grades or 25%, 3% molybdenum duplex grades. These materials are considerably more expensive than standard 300-series austenitic stainlesses and see limited use in critical applications. Higher alloyed duplex grades have become the universal standard for high-pressure injection pumps, especially those used in offshore locations. The high mechanical properties enable the design of lighter, smaller pumps. The weight saving is an important factor in offshore applications.

Many large sea water pumps are constructed of cast iron with bronze internals. Provided the velocities are not too high, this combination of materials has been known to provide approximately 20 years of service in some large vertical pumps. Nickel aluminum bronze is preferred over tin bronze for the impeller because it is stronger, has better resistance to high velocity, and is more easily weld-repaired.

Monel shafting is no longer commonly specified for sea water pumping applications. This material is expensive and will develop pitting in stagnant water. Several grades of stainless steel will provide a combination of strength and corrosion resistance equivalent to Monel at a significantly lower cost. These include Nitronic 50 and several of the higher alloyed duplex grades, such as Ferralium.

When specifying materials for sea water pumps, the designer should also consider whether the water will be chlorinated, and, if so, where the chlorine is to be added. Chlorine is added to cooling waters to kill marine organisms that cause biofouling. The chlorine may be added continuously at low levels or as a shock treatment at periodic intervals. Chlorination at normal levels of up to 2 ppm does not appear to be detrimental to alloys commonly used in saline water pumps. However, an injection should be made far enough upstream of the pump intake so that the dilution occurs ahead of the pump. When an injection is made at or near the pump intake, copper alloys, stainless steels, and Ni-Resist may suffer accelerated corrosion. Recent work has shown that the corrosion rate of stainless steels will begin to increase at chlorine levels of about 5 ppm.

Galvanic considerations will also play a role in the material selection for saline water pumps. In general, the pump internals should be cathodic to the pump case. Coatings should be avoided, especially on the anodic component. Flaws or defects in a coating will expose a small area of base metal. Corrosion will then proceed at a high rate due to the extremely unfavorable area ratio. It is also inadvisable to use carbon or graphite bearings in sea water pumps. These are at the noble end of the galvanic series and are likely to cause a galvanic corrosion of stainless steels or other alloys with which they come in contact.

Table 7 indicates a number of material combinations commonly specified for seawater pumps.

**Hydrocarbons** Pure hydrocarbons are not corrosive, but they frequently contain small amounts of water or other substances that make them corrosive. The material selection guidelines for a variety of hydrocarbon services have been developed by the American Petroleum Institute and are reproduced in Tables 8 and 9. These tables give general guide-

**TABLE 7** Materials for saline water pumps

	Component	Reference	Alternative	Non-ferrous
Vertical Pumps	Column/Head	Ni-Resist <sup>1</sup>	316L	C614 <sup>4</sup>
	Diffuser	Ni-Resist <sup>1</sup>	CF-8M/CF-3M <sup>2</sup>	C952 <sup>4</sup>
	Bowl	CF-8M/CF-3M <sup>2</sup>	Ni-Resist <sup>3</sup>	C952 <sup>(4)</sup>
	Inlet Ball	Ni-Resist	Ni-Resist	C952 <sup>4</sup>
	Impeller	CF-8M/CF-3M <sup>2</sup>	CF-8M/CF-3M <sup>2</sup>	C958 <sup>4</sup>
Centrifugal Pumps	Case	Ni-Resist	CF-3M/CF-8M <sup>5</sup>	C952 <sup>4</sup> G/M Bronze
	Impeller	CF-3M/CF-8M <sup>2</sup> CD4MCu <sup>4</sup>	CF-3M/CF-8M <sup>2</sup> CD4MCu <sup>4</sup>	C958 <sup>4</sup> Monel
	Component	Deaerated Brine	Low pH Brine – H <sub>2</sub> S	
High Pressure Multistage —Oilfield Brines	Case	Duplex <sup>6</sup> C952 <sup>4</sup>	5-6% Mo Alloy <sup>7</sup> CF-8M	
	Impeller	Duplex <sup>6</sup> CF-8M C952 <sup>4</sup>	5-6% Mo Alloy <sup>7</sup>	

<sup>1</sup>Furnace stress relieved

<sup>2</sup>CF-8M should be postweld heat treated

<sup>3</sup>Erosion – corrosion may be high

<sup>4</sup>Postweld heat treat required

<sup>5</sup>Galvanic protection desirable to prevent crevice corrosion

<sup>6</sup>High alloy grade with 25 Cr, 5-6 Ni, 3 Mo, and N

<sup>7</sup>20 Cr, 19-25 Ni, 5-6 Mo, and N



**TABLE 8** Material classes for centrifugal pump services (Courtesy of the American Petroleum Institute, Reference 16)

CAUTION: This table is intended as a general guide. It should not be used without a knowledgeable review of the specific services involved.

Service	On-Plot Process Plant	Off-Plot Transfer & Loading	Temperature Range		Pressure Range	Material Class (see Tble 9)	See Reference Note
			Deg C	Deg F			
Fresh water, condensate, cooling-tower water	X	X	< 100	< 212	All	I-1 or I-2	
Boiling water and process water	X	X	< 120	< 250	All	I-1 or I-2	5
	X	X	120–175	250–350	All	S-5	5
	X	X	> 175	> 350	All	C-6	5
Boiler feed water							
Axially split	X	X	>95	>200	All	C-6	
Double casing (barrel)	X	X	>95	>200	All	S-6	
Boiler circulator	X	X	>95	>200	All	C-6	
Foul water, reflux drum water, water draw, and hydrocarbons containing these waters, including reflux streams	X	X	< 175	< 350	All	S-3 or S-6	6
Propane, butane, liquefied petroleum gas, and ammonia (NH <sub>3</sub> )	X	X	< 230	< 450	All	S-1	
Diesel oil; gasoline, naphtha; kerosene; gas oils; light, medium, and heavy lube oils; fuel oil; residuum;	X	X	< 230	<450	All	S-1	
crude oil; asphalt; synthetic crude bottoms	X		230–370	450–700	All	S-6	6, 7
Noncorrosive hydrocarbons, e.g., catalytic reformate, isomaxate, desulfurized oils	X	X	> 370	> 700	All	C-6	6
Xylene, toluene, acetone, benzene, furfural, MEK, cumene	X	X	230–370	450–700	All	S-4	7
Sodium carbonate, doctor solution	X	X	<230	<450	All	S-1	
Caustic (sodium hydroxide) concentration of $\leq 20\%$	X	X	<175	<350	All	I-1	
	X	X	<100	<210	All	S-1	8
			$\geq 100$	$\geq 200$	All		9
Sea water	X	X	< 95	< 200	All	—	10

(continues)

**TABLE 8** Continued.

Service	On-Plot Process Plant	Off-Plot Transfer & Loading	Temperature Range		Pressure Range	Material Class (see Table 9)	See Reference Note
			Deg C	Deg F			
Sour water	X	X	<260	<470	All	D-1	
Sulfur (liquid state)	X	X	All	All	All	S-1	
FCC slurry	X	X	<370	<700	All	C-6	
Potassium carbonate	X	X	<175	<350	All	C-6	
	X	X	<370	<700	All	A-8	
MEA, DEA, TEA-stock solutions	X	X	<120	<250	All	S-1	
DEA, TEA-lean solutions	X	X	<120	<250	All	S-1	8
MEA-lean solution (CO <sub>2</sub> only)	X	X	80–150	175–300	All	S-9	8
MEA-lean solution (CO <sub>2</sub> and H <sub>2</sub> S)	X	X	80–150	175–300	All		8, 11
MEA, DEA, TEA, rich solutions	X	X	<80	<175	All	S-1	8
Sulfuric acid concentration >85%	X	X	<38	<100	All	S-1	6
85%–< 1%	X	X	<230	<450	All	A-8	6
Hydrofluoric acid concentration of > 96%	X	X	<38	<100	All	S-9	6

1. The materials for pump parts for each material class are given in Table 9.
2. Separate materials recommendations should be obtained for services not clearly identified by the service descriptions listed in this table.
3. Cast iron casings, where recommended for chemical services, are for nonhazardous locations only. Steel casings (S-1 or I-1) should be used for pumps in services located near process plants or in any location where released vapor from a failure could create a hazardous situation or where pumps could be subjected to hydraulic shock, for example, in loading services.
4. Mechanical seal materials: For streams containing chlorides, all springs and other metal parts should be Alloy 20 or better. Buna-N and Neoprene should not be used in any service containing aromatics. Viton should be used in services containing aromatics above 200°F (95°C).
5. Oxygen content and buffering of water should be considered in the section of material.
6. The corrosiveness of foul waters, hydrocarbons over 450°F (230°C), acids and acid sludges may vary widely. A materials recommendation should be obtained for each service. The material class previously indicated will be satisfactory for many of these services but must be verified.
7. If production corrosivity is low, Class S-4 materials may be used for services at 451–700°F (231–370°C). A separate materials recommendation should be obtained in each instance.
8. All welds shall be stress relieved.
9. Alloy 20 or Monel pump material and double mechanical seals should be used with a pressurized seal oil system.
10. For seawater service, the purchaser and the vendor should agree on the construction materials that best suit the intended use.
11. Class A-7 materials should be used, except for carbon steel casings.

**TABLE 9** Materials for pump parts (Courtesy of the American Petroleum Institute, Reference 16)

		Material Class and Material Abbreviations <sup>a</sup>													
Part	Full <sup>b</sup> Compliance Material?	I-1	I-2	S-1	S-3	S-4	S-5	S-6	S-8	S-9	C-6	A-7	A-8	D-1	
		Cl	Cl	STL	STL	STL	STL	STL	STL	STL	STL	12% CHR	AUS	316 AUS	DUPLEX
		Cl	BRZ	Cl	NI-RESIST	STL	STL 12% CHR	12% CHR	316 AUS	MONEL	12% CHR	AUS <sup>1,2</sup>	316 AUS <sup>1,2</sup>	DUPLEX	
Pressure casing	Yes	Cast iron	Cast iron	Carbon steel	Carbon steel	Carbon steel	Carbon steel	Carbon Steel	Carbon steel	Carbon steel	12% CHR	AUS	316 AUS	Duplex	
Inner case parts (bowls, diffusers, diaphragms)	No	Cast iron	Bronze	Cast iron	Ni-Resist	Cast iron	Carbon steel	12% CHR	316 AUS	Monel	12% CHR	AUS	316 AUS	Duplex	
Impeller	Yes	Cast iron	Bronze	Cast iron	Ni-Resist	Carbon steel	Carbon steel	12% CHR	316 AUS	Monel	12% CHR	AUS	316 AUS	Duplex	
Case wear rings	No	Cast iron	Bronze	Cast iron	Ni-Resist	Cast iron	12% CHR hardened	12% CHR hardened	Hard faced 316 AUS <sup>3</sup>	Monel	12% CHR hardened	Hard faced AUS <sup>3</sup>	Hard faced 316 AUS <sup>3</sup>	Duplex <sup>3</sup>	
5.41 Impeller wear rings	No	Cast iron	Bronze	Cast iron	Ni-Resist	Cast iron	125 CHR hardened	12% CHR hardened	Hard faced 316 AUS <sup>3</sup>	Monel	12% CHR hardened	Hard faced AUS <sup>3</sup>	Hard faced 316 AUS <sup>3</sup>	Duplex <sup>3</sup>	
	Yes	Carbon steel	Carbon steel	Carbon steel	Carbon steel	Carbon steel	AISI 4140	AISI 4140 <sup>4</sup>	316 AUS	K-Monel	12% CHR	AUS	316 AUS	Duplex	
Shaft sleeves, packed pumps	No	12% CHR hardened	Hard Bronze	12% CHR hardened	12% CHR hardened or hard faced	12% CHR hardened or hard faced	12% CHR hardened or hard faced	12% CHR hardened or hard faced	Hard faced 316 AUS <sup>3</sup>	K-Monel, hardened	12% CHR hardened or hard faced	Hard faced AUS <sup>3</sup>	Hard faced 316 AUS <sup>3</sup>	Duplex <sup>3</sup>	
Shaft sleeves, mechanical seals	No	AUS or 12% CHR	AUS or 12% CHR	AUS or 12% CHR	AUS or 12% CHR	AUS or 12% CHR	AUS or 12% CHR	AUS or 12% CHR	AUS or 12% CHR	K-Monel, hardened	AUS or 12% CHR	AUS	316 AUS	Duplex	
Throat bushings	No	Cast iron	Bronze	Cast iron	Ni-Resist	Cast iron	12% CHR	12% CHR	316 AUS	Monel	12% CHR hardened	AUS	316 AUS	Duplex	
Interstage sleeves	No	Cast iron	Bronze	Cast iron	Ni-Resist	Cast iron	12% CHR hardened	12% CHR hardened	Hard faced 316 AUS <sup>3</sup>	K-Monel, hardened	12% CHR hardened	Hard faced AUS <sup>3</sup>	Hard faced 16 AUS <sup>3</sup>	Duplex <sup>3</sup>	
Interstage bushings	No	Cast iron	Bronze	Cast iron	Ni-Resist	Cast iron	12% CHR hardened	12% CHR hardened	Hard faced 316 AUS <sup>3</sup>	K-Monel, hardened	12% CHR hardened	Hard faced AUS <sup>3</sup>	Hard faced 316 AUS <sup>3</sup>	Duplex <sup>3</sup>	

(continues)

TABLE 9 Continued.

		Material Class and Material Abbreviations <sup>a</sup>													
Part	Full <sup>b</sup> Compliance Material?	I-1	I-2	S-1	S-3	S-4	S-5	S-6	S-8	S-9	C-6	A-7	A-8	D-1	
		CI	CI	STL	STL	STL	STL	STL	STL	STL	STL	12% CHR	AUS	316 AUS	DUPLEX
		CI	BRZ	CI	NI-RESIST	STL	STL 12% CHR	12% CHR	316 AUS	MONEL	12% CHR	AUS <sup>1,2</sup>	316 AUS <sup>1,2</sup>	DUPLEX	
Seal gland	Yes	316 AUS <sup>5</sup>	316 AUS <sup>5</sup>	316 AUS <sup>5</sup>	316 AUS <sup>5</sup>	316 AUS <sup>5</sup>	316 AUS <sup>5</sup>	316 AUS <sup>5</sup>	316 AUS <sup>5</sup>	Monel	316 AUS <sup>5</sup>	316 AUS <sup>5</sup>	316 AUS <sup>5</sup>	Duplex <sup>5</sup>	
Case and gland studs	Yes	Carbon steel	Carbon steel	AISI 4140 steel	AISI 4140 steel	AISI 4140 steel	AISI 4140 steel	AISI 4140 steel	AISI 4140 steel	K-Monel, hardened <sup>3</sup>	AISI 4140 steel	AISI 4140 steel	AISI 4140 steel	Duplex <sup>8</sup>	
Case gasket	No	AUS, spiral wound <sup>6</sup>	AUS, spiral wound <sup>6</sup>	AUS, spiral wound <sup>6</sup>	AUS, spiral wound <sup>6</sup>	AUS, spiral wound <sup>6</sup>	AUS, spiral wound <sup>6</sup>	AUS, spiral wound <sup>6</sup>	316 AUS, spiral wound <sup>6</sup>	Monel, spiral wound, PTFE filled <sup>5</sup>	AUS, spiral wound <sup>6</sup>	AUS, spiral wound <sup>6</sup>	316 AUS, spiral wound <sup>6</sup>	Duplex SS spiral wound <sup>6</sup>	
Discharge head/suction can	Yes	Carbon steel	Carbon steel	Carbon steel	Carbon steel	Carbon steel	Carbon steel	Carbon steel	Carbon steel	Carbon steel	AUS	AUS	316 AUS	Duplex	
Column/bowl shaft bushings	No	Nitrile <sup>7</sup>	Bronze	Filled carbon	Nitrile <sup>7</sup>	Filled carbon	Filled carbon	Filled carbon	Filled carbon	Filled carbon	Filled carbon	Filled carbon	Filled carbon	Filled carbon	
Wetted fasteners (bolts)	Yes	Carbon steel	Carbon steel	Carbon steel	Carbon steel	Carbon steel	316 AUS	316 AUS	316 AUS	K-Monel	316 AUS	316 AUS	316 AUS	Duplex	

The abbreviation above the diagonal line indicates the case material; the abbreviation below the diagonal line indicates trim material.

Abbreviations are as follows: BRZ = bronze, STEL = steel, 12% CHR = 12% chrome, AUS = austenitic stainless steel, CI = cast iron, 316 AUS = Type 316 austenitic stainless steel.

Parts designated as *full compliance* materials shall meet all the requirements of the industry specification listed for the material. Parts not designated as *full compliance* materials shall be made of materials with applicable chemical composition but need not meet the other requirements of the listed industry specification.

<sup>1</sup>Austenitic stainless steels include ISO Types 683-13-10/19 (AISI Standard Types 302, 303, 304, 316, and 347). If a particular type is desired, the purchaser will so state.

<sup>2</sup>For vertically suspended pumps with shafts exposed to liquid and running in bushings, the shaft shall be 12 percent chrome, except for Classes S-9, A-7, A-8, and D-1. Cantilever (Type VS5, API 610) pumps may utilize AISI 4140 where the service liquid will allow.

<sup>3</sup>Unless otherwise specified, the need for hard-facing and the specific hard-facing material for each application shall be determined by the vendor and described in the proposal. Alternatives to hard-facing may include opening running clearances or the use of non-galling materials, such as Nitronic 60 and Waukesha 88, depending on the corrosiveness of the pumped liquid.

<sup>4</sup>For Class S-6, the shaft shall be 12 percent chrome if the temperature exceeds 350°F (175°C) or if used for boiler feed service (refer to Table 8).

<sup>5</sup>The gland shall be furnished with a non-sparking floating throttle bushing of a material such as carbon graphite or glass-filled PTFE. Unless otherwise specified, the throttle bushing shall be premium carbon graphite.

<sup>6</sup>If pumps with axially split casings are furnished, a sheet gasket suitable for the service is acceptable. Spiral-wound gaskets should contain a filler material suitable for the service.

<sup>7</sup>Alternate materials may be substituted for liquid temperatures greater than 110°F (45°C) or for other special services.

<sup>8</sup>Unless otherwise specified, APSI 4140 steel may be used for non-wetted case and gland studs.

lines that do not necessarily apply to every situation. In many hydrocarbons, hydrogen sulfide is present as a contaminant.

Hydrogen sulfide causes a form of stress corrosion cracking in hardenable steels and other alloys. Additional precautions must be taken when hydrogen sulfide is present, consisting of special heat treatments to limit hardness. Details concerning the requirements for specific materials can be found in NACE standard MR-01-75.

Naphthenic acid is an organic acid that is found in many crude oils. It causes corrosion problems at temperatures in excess of 450°F (232°C). Austenitic stainless steels containing molybdenum, either 316 or 317, are required for effective resistance against naphthenic acids.

Amine solutions have caused cracking in welded carbon steel components that have not been post-weld heat treated. Although repairs to carbon steel casings may not require post-weld heat treatment, it is prudent to specify this for welds made to rotating components or piping welds to a casing.

## **MATERIALS FOR SLURRY AND ABRASIVE SERVICES**

---

The construction materials for pumps that handle high concentrations of suspended solids are often based upon high bulk hardness. In many applications, coatings, hard liners, and weld overlays are used to specifically increase the surface hardness of the internal wetted portions within the pump. However, many of the slurry applications use non-metallics that do not have high bulk hardness because of their unique qualities.

**Nonmetallics** Contrary to “harder is better,” a good number of slurry pumps use non-metallic materials, such as rubber, that absorb the kinetic energy of the solid particles through a large elastic deformation of the surface. Natural rubber is the most commonly used material since it provides good wear resistance with abrasive particles less than approximately 0.25 to 0.38 in (6 to 9 mm). Rubber linings pose a problem in the bonding of this outer shell to a metallic substrate. This is particularly true for cut water areas of a casing and, of course, attachment to metal skeletons of an impeller. Care must be taken also in considering the liquid phase of the slurry and the temperature of the application, both of which can degrade the rubber.

Other factors to consider when using elastomeric liners include pressure in the flow passage versus the pressure between the liner and the wall, and temperature, since rubber softens around 240°F (115°C). It is also important to consider the size of the particles greater than 0.2 in (5 mm) if they are dull or greater than 0.08 in (2 mm) if they are sharp, and the head per stage.

**Metals** In mildly abrasive services, carburized steels are sometimes used to increase the wear life of components. Carbon is diffused into the surface of carbon steel, which, after a hardening heat treatment, can achieve a surface hardness of 60  $R_c$ . This gas diffusion heat treatment can produce high hardness layers that penetrate the outside surface of the pump component to a depth of approximately 0.080 to 0.090 in (2.0 to 2.3 mm). However, after carburization, the materials are impossible to weld-repair without cracking. Using a special process, usually a vacuum furnace, carburizing has been employed in the surface hardening of the 12% chromium stainless steels, such as CA15, for abrasive services where mild corrosion is expected.

The most commonly used materials for severe slurry services are the abrasion-resistant cast irons found in ASTM A532. Essentially, three main classes and several types of alloys are covered in this specification. The most widely employed material in slurry applications is the Class III hard irons. A brief description of this class of abrasion-resistant iron is as follows:

ASTM A532 Grade	Composition (Cr, Ni, and Mo)	Hardness (BHN)
Class I: Type A (Ni-Hard)	1–11% Cr, 3–7% Ni	500–600
Class II: Type A, B, C, D, E	11–23% Cr, 0.5–3.5% Mo	450 (annealed for machining) 600 (hardened)
Class III: Type A (26% chrome iron, original trade name of HC-250)	23–28% Cr	400–600 depending on desired properties

All three classes contain a martensitic matrix with secondary hard phases of chrome and iron carbides that increase the wear resistance. The molybdenum in class II increases the material's hardenability for thicker cross sections.

In general, it should be stressed that machining and welding these three classes of material is impossible. Another important consideration is the role of carbon content on corrosion, erosion, and fracture resistance. High-carbon contents reduce corrosion resistance because any chromium tied up as chrome carbide is no longer available to form a protective chrome oxide layer. Although beneficial with regard to erosion and abrasion resistance, high-carbon content increases the susceptibility to breakage by thermal and mechanical shocks.

To counteract this problem, a number of precautionary measures must be adopted to enhance the serviceability of this class of material. First, slow warm-up cycles must be instituted, typically around 100 to 150°F per hour.<sup>14</sup> Another strategy is to lower the hardness from about 600 to 400 Brinell by a partial anneal. This measure reduces brittleness, but at the expense of erosion resistance.

***Linings, Inserts, and Coatings*** The low ductility and toughness of A532 cast irons do not permit their usage with primary pressure boundaries according to ASME code and API regulations. This restricts the use of hard irons to internal wetted parts. Therefore, it is necessary to use steel pressure casings with hard materials as liners. A common slurry pump consists of ASTM A532, Class III, Type A (HC-250) impellers and replaceable HC-250 wear liners for the volute and for both the inlet and outlet ends of the pump casing.

Since pump erosion is often quite localized, in some instances it is more practical to install replaceable, mechanically attached inserts at high wear areas, such as the cut water. These are typically made of sintered tungsten carbide or some other hard material. Newer materials, such as ceramic composites and toughened ceramics, should perform better than the "cermets" used in the past.

Several problems, however, can occur with mechanically attached inserts. One problem is protecting the fastening device against erosive wear. Another problem is the insert's tendency to act as a turbulence riser due to an imperfect fit or erosion-induced crevices and offsets. Limited success has been achieved with weld-applied overlays of Stellite and other hardfacing materials. Weld overlays are extensively utilized, but several problems may occur. These include a propensity for cracking, debonding resulting from preferential corrosion of the bond line, dilution of the hardfacing material with the substrate, and potential uneven thickening after machining.

Thermal spray coatings as well as diffusion surface treatments have been used in pump applications for fluids containing high concentrations of suspended solids. Spray coatings are restricted to areas within the pump, accessible by the line of sight. Diffusion-produced coatings are not limited by this constraint. A disadvantage of diffusion processes is that they are performed at high temperatures that can negatively influence the base material properties. Diffusion coatings can range from traditional gas carburizing to the diffusion of high chromium alloys. These coatings increase the sur-

face hardness of the component and, depending upon the process, can increase the material's surface hardness to values in excess of  $60 R_c$ . Diffusion layers can be produced to a depth of approximately 0.100 in (2.54 mm). One item of caution: these coatings usually render the material unweldable after application. For this reason, steps must be taken to protect areas of anticipated welding, such as attachment piping. Future weld repairs are not possible unless the coating is completely worn off or removed.

Through the years, developments in thermal spray equipment have enhanced the acceptability of this surface modification process. Thermal spray processes employ the transfer of a material onto another by raising the temperature of the hard-facing material, usually in powder form, and projecting it against the component that requires the additional erosion resistance. The bond strength between the hard-faced material and the substrate material is directly influenced by the maximum velocity that the particles of molten material achieve in a given thermal spray process. The greatest bond strength is achieved by the highest velocity process. The typical thermally sprayed materials used in pumps to resist solid particle erosion damage are as follows:

- Nickel chromium boride coatings
- Cobalt-based hardfacing coatings
- Tungsten carbide coatings
- Solid particle tungsten carbide loaded (1) or (2)

The processes used to apply the above hardfacing materials are as follows:<sup>15</sup>

Process	Typical Particle Velocity
Flame spray	100 ft/s (30.5 m/s)
Plasma spray	800 ft/s (244 m/s)
D-Gun (Union Carbide tradename for detonation gun process)	800 ft/s (244 m/s)
HVOF (high velocity oxy-fuel)	3000 ft/s (915 m/s)

The severity of the service usually dictates the process. In the past, thermal spray coatings, for the most part, were tungsten carbide and the diffusion coatings were high in borides. It was found that for spray coatings an increased performance could be achieved by applying them over erosion-resistant substrates. This is a challenge because the high-chromium, carbon, abrasion-resistant materials are thermal-crack-sensitive. Overlay coatings, if applied several times, are thicker but are more prone to cracking, chipping, and spalling. An alternative is to use carburized carbon steel or 12% chromium stainless steel centrifugal pump components for mildly corrosive environments. Coatings are frequently used to increase the life of plungers in reciprocating pumps for slurry services.

Another process for applying hard-faced materials is by laser consolidation. This process can be accomplished in two different ways. The first case is one in which a laser beam is used to melt a thermally sprayed coating applied upon a substrate. The other process is to simultaneously melt the substrate while applying a hard-faced material. In either case, the principle is to use the hard-faced material as a consumable in a laser-welding operation. Since laser welding is a rapid process, very little dilution of the hard facing material is produced. This allows for much thinner coatings that are less prone to thermally induced cracking during an operation. In addition, since there is little dilution, the hardness and chemistry of the coating are very consistent. This provides for uniform erosion resistance throughout the entire coating thickness.

**SUMMARY**

---

It should be clear from the discussion of materials for saline waters and hydrocarbon applications that the selection of materials for a pump is a complicated exercise, requiring knowledge of the engineering properties of the material, its fabrication characteristics, and corrosion and erosion resistances. An in-depth discussion of the considerations governing material selections for other pump applications, such as the chemical industry, mining industry, and others, is beyond the scope of this section, but a number of references are included to provide additional guidance. Past experience is often helpful, but it is recommended that the materials selections be reviewed by a metallurgist or corrosion engineer with experience in this area, especially for critical applications or those applications with which you are not familiar.

**REFERENCES**

---

1. Peterson, M. B. "Classification of Wear Processes." *Wear Control Handbook*. pp. 9–15, 1980.
2. Sparkar, A. D. "Fretting." *Wear of Metals*. pp. 116–121, 1976.
3. Zum Gahr, K. "Abrasion Wear on Metallic Materials." pp. 73–104, 1981.
4. Miller, R. S. "Corrosion in Pumps." Texas A&M University Pump Proceedings. pp. 119–127, 1992.
5. Miller, J. E. "Miller Number." *Chemical Engineering*. July 1974, pp. 103–106.
6. "Wear of Pumps." *Metals Handbook, Vol. 18*. ASM International: Metals Park, OH, 1992.
7. Chen, J. H., and Hu, Z. W. "Main Causes of Slurry Wear of Various Materials Under Field and Laboratory Conditions." *Wear of Metals*. pp. 9–13, 1989.
8. "Coal Slurry Feedpump for Coal Liquefaction." Final Report EPRI AF-853. Study Conducted Under EPRI Project Manager H. Gilman by the Rocketdyne Division of Rockwell International, pp. 8–67, 1978.
9. Ives, L. K., and Ruff, A. W. "Electron Microscopy Study of Erosion Damage in Copper." *Erosion: Prevention and Useful Applications*. ASTM STP 664, pp. 5–32, 1977.
10. Hertzberg, R. W. "Cyclic Stress and Strain." *Deformation & Fracture Mechanics of Engineering Materials*. pp. 415–462, 1976.
11. Kesnil, M., and Lukas, P. "Fatigue of Metals." *Materials Science Monographs*, 7, pp. 9–16, 1980.
12. LaQue, F. L. "Marine Corrosion Causes and Prevention." pp. 84, 1975.
13. Schumacher, W. J. "Metals for Nonlubricated Wear." *Machine Design*. pp. 57–59, 1976.
14. Wong, G. S., and Ackerman, R. E. "Coal Slurry Pump Development." Rockwell International Report RI/RD-38-217, pp. 83–217, 1984.
15. Bushan, B., and Gupta, B. K. "Coating Deposition by Hard Facing." *Handbook of Tribology*. pp. 8.1–8.26, 1991.

**FURTHER READING**

---

- Archard, J. F. "Contact and Rubbing of Flat Surfaces." *Journal of Applied Physics*. Vol. 24, pp. 981–988, 1953.
- Bitter, J. G. A. *Wear*. Volume 6, pp. 5–21, 169–190, 1961.
- Butler, G., and Ison, H. *Corrosion and Its Prevention in Waters*. Robert E. Krieger Publishing: Huntington, NY, 1978.



- “Corrosion.” *Metals Handbook*. Ninth Edition, Vol. 13. ASM International: Metals Park, OH.
- Dillon, C. P. *Corrosion Control in the Chemical Process Industries*. McGraw Hill: New York, 1986.
- Hokkirigawa, K., and Kato, K. “Theoretical Estimation of Abrasive Wear Resistant Base on Microscopic Wear.” *Wear of Metals*. pp. 1–8, 1989.
- Holm, R. “Theory of Hardness & Measurements Applicable to Contact Problems.” *Journal of Applied Physics*. Vol. 20, pp. 319–327, 1949.
- Kotecki, D. J., and Ogborn, J. S. “Abrasion Resistance of Iron-Based Hardfacing Alloys.” *Welding Research Supplement*. pp. 269-s–278-s.
- LaQue, F. L. *Marine Corrosion—Causes and Prevention*. Electrochemical Society: Princeton, NJ, 1975.
- LaQue, F. L., and Copson, H. R. *Corrosion Resistance of Metals and Alloys, 2nd Edition*. Reinhold Publishing: NJ, 1963.
- McCaul, C. “Evaluation of Corrosion Failures in Pumps.” *ASTM STP 1000*. ASTM: Philadelphia, PA, 1990.
- Rabonowicz, E. “Wear Coefficients—Metals.” *Wear Control Handbook*. pp. 475–506, 1980.
- Sparkar, A. D. “Abrasive Wear.” *Wear Of Metals*. pp. 69–73, 1976.
- Speller, F. N. *Corrosion—Causes and Preventions*. Third Edition, McGraw Hill: New York, 1951.
- Uhlig, H. H. *Corrosion and Corrosion Control*. John Wiley and Sons: New York, 1967.
- Uhlig, H. H. *Corrosion Handbook*. Electrochemical Society. John Wiley and Sons: New York, 1948.

---

# SECTION 5.2

---

# MATERIALS OF CONSTRUCTION FOR NONMETALLIC (COMPOSITE) PUMPS

---

FREDERIC W. BUSE

The use of composite materials is playing an increasing role in the manufacture of industrial pumps due to the cost savings they offer in manufacturing, installation, and operation. Composite parts can be molded to near “net shape.” This eliminates the cost of secondary machining to attain the final part. Because one composite material can replace two or three different grades of metal part, the combining of several parts into one assembly is possible. This parts integration reduces assembly time, reduces inventory, and ultimately reduces manufacturing costs.

Because composite pumps weigh less than metal pumps, they are easier to handle during installation and maintenance. Further, because composites naturally dampen vibration, a composite pump operates more quietly than a comparable metallic pump.

The corrosion resistance of composites is superior to metals. For this reason, a composite pump’s life can be significantly greater than a metallic pump. When the amortization costs of both composite and metallic pumps are calculated, the composite pump has the cost advantage.

## **FACTORS TO CONSIDER**

---

Factors to consider in using composite materials for pump parts are mechanical properties, abrasion and corrosion resistance, temperature, costs, weight and insulating properties, exposure to sun, fire resistance, and chemical resistance.

**Mechanical Properties** The composite pump or parts must be designed to withstand the loads/stresses of the operating conditions. If the existing metal part design were simply replicated in a composite, the composite part could fail. Excessive stresses for a composite pump at the nozzle area or at the bearing housing can cause the pump housing to creep. The result is part distortion or bending and shaft misalignment.

A solution to this problem is to calculate the stress levels in the composite part and design within the composite's elastic limit. These complex stress calculations are now done on a routine basis with the aid of a computer and non-linear FEA (finite element analysis) programs.

**Abrasion and Corrosion Resistance** The abrasive wear on 316 stainless steel is caused by the continuing removal of the metal's protective oxidation layer on the metal's surface. Composites do not need a protective layer and therefore have better resistance to mild abrasives. However, some composites are subject to corrosion by caustic liquids.

As background, metallic materials deteriorate from any one or combination of the following electrochemical reactions: galvanic action, pitting, corrosive attack, crevice corrosion, intergranular corrosion, and stress corrosion. The temperature, pH, formation, removal of an oxide corrosion barrier, or the velocity of the solution affects the rate of corrosion in a metal's surface.

**Temperature** Most composite pump materials are limited to operating temperatures below 300°F (150°C) for non-corrosive liquids and under 250°F (120°C) for corrosive liquids. Like metals, there is a reduction of mechanical properties for composites with increasing temperature.

**Costs** There are three areas of cost to consider when evaluating a composite part: development costs, initial capital costs, and cost savings.

Developing costs would include the following:

- Designing the part for composites
- Evaluating and testing alternative composite materials
- Prototype molding the parts

Initial capital costs are in the cost of the molds to produce the parts. Cost savings in manufacture and use include the following:

- Little or no corrosion increases the time between maintenance and extends the useful life of the pump.
- Reduced secondary machining cost at manufacture (the parts are near "net shape")
- Integrating several parts into one assembly results in a less expensive part, lower inventories, and less assembly time.
- Quality control cost is reduced as part tolerance is primarily determined by the mold.

The initial cost of a composite pump versus a metallic pump is typically as follows:

- equal or slightly more expensive than an all 316 stainless steel pump
- 80% the cost of an Alloy 20 pump
- 50% the cost of a Hastelloy C pump

**Weight and Insulation Properties** With a significant reduction in weight compared to metal, the composite pump is easier to handle during installation and maintenance removal. As an example, an immersion sump pump that is usually 3–10 ft long weighs only 10–30% of a comparable metal pump.

Added insulation on the pump to conserve high temperature process heat is usually not needed on a composite pump, as the composite is a natural insulator when compared to metal. This saves the cost to fabricate an insulation cover over the pump and provides easier access for maintenance.

**Exposure to the Sun** Some composites are susceptible to the UV (ultraviolet) rays of the sun. 2% carbon black in the resin is an effective UV blocker. HALS (hindered amine

light stabilizers) can also be added to the composite to effectively prevent damage by the UV rays of the sun.

**Fire Resistance** In a severe fire, thermoplastic composites will melt and burn and thermoset composites will char and ash. If the composite reaches 400–500°F (204–260°C), there will be distortion of the pump and the pump will be lost. Because of the insulating properties of a composite pump housing, however, the liquids inside the pump will be cooler than if the pump were metal.

Fire retardant additives can be used with composite materials, but they may affect optimum mechanical properties. Most thermoset composites are self-extinguishing in a fire, but the pump manufacturer should be consulted to determine if there is a potential for toxic fumes if the composite is burned.

## CHEMICAL RESISTANCE OF COMPOSITES

---

Composites do not corrode because they are non-conductive. Therefore, an electrochemical reaction does not take place. (An exception to this may be when electrically conductive long carbon fibers are used in the wrapping of a pressure vessel or a pump housing.) Their lack of resistance to different chemical fluids can degrade composite materials. This degrading can be in the resin, the reinforcing fiber, or in the coupling agent between the resin and fiber. If a composite material is going to be degraded, it will usually be immediate. Fluid temperature and concentrations are vital when selecting the appropriate composite material. With some composites, such as nylon, the pH can be a factor when selecting the best composite material for the application.

As an initial test, a sample coupon of the composite can be immersed in the process liquid and the results noted. A more definitive method is to review the composite manufacturer's informational database on chemical resistance. Many composite manufacturers have run extensive chemical resistance studies of their materials in a variety of liquids at set temperatures over time. The composite's physical properties are measured before and after the test period and the percentage deterioration versus time is documented in the manufacturer's literature.

The Hydraulic Institute, discussed later, has a polymer material selection guide that recommends specific composites for various liquids.

## TYPES OF COMPOSITES

---

Composites can be divided into two general groups of organic compounds: thermoplastic and thermoset.

**Thermoplastic** Thermoplastic materials can be repeatedly melted and solidified. They do not go through an irreversible chemical process when heated. Amorphous thermoplastics resins have a broad softening range and are suitable for processes that require good melting strength like thermoforming. They can be transparent in color but do have limited chemical resistance.

Crystalline thermoplastic resins have a sharp melt point and are better suited to molding processes like injection molding where melt strength is not required. They have excellent chemical resistance. Their physical properties can be modified and improved with the addition of glass or carbon fiber, tougheners, or mica. Chart 1 shows the effect of various reinforcement materials on selected polymers.

Some of the thermoplastic processes that are used to form pump parts are injection molding, vacuum forming, extrusion, and blow molding. Thermoplastic resins suitable for pump applications include fluoropolymers, acrylics, polyethylene, polypropylene, polyvinyl chloride, and others. The allowable temperature range for these materials is from

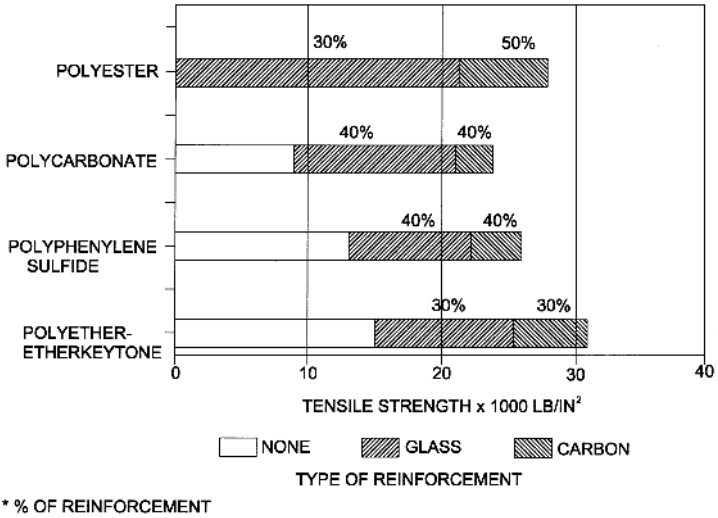


CHART 1 Thermoplastics strength versus reinforcement

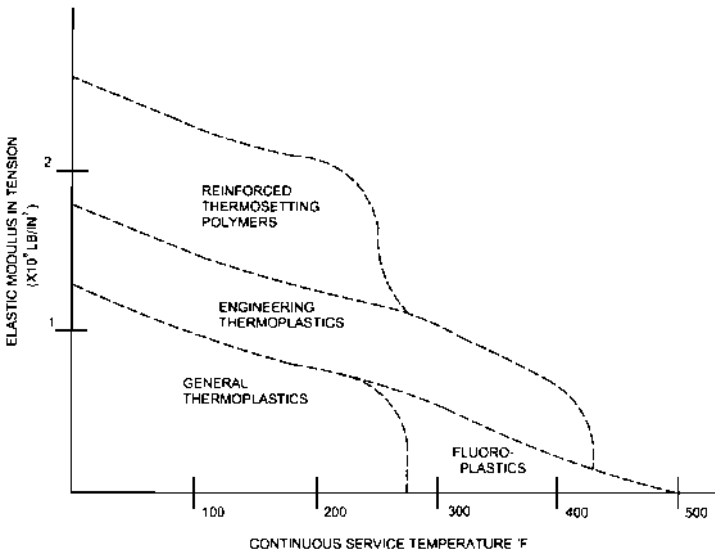


FIGURE 1 The effect of temperature on modulus of elasticity

130–300°F (54–150°C), depending on the material. Figure 1 shows the elastic modulus versus service temperature for various polymers.

**Thermoset** Thermoset materials, when heated, go through an irreversible chemical change with the result that the material will not soften when reheated. Thermoset resins are generally reinforced with glass fiber, linen, carbon fiber, graphite, minerals and so on.

**TABLE 1** Differences between Thermoset and Thermoplastic

Process	Thermoset	Thermoplastic
Average range of molded thickness	.030 to 2.00 in (0.75 to 50 mm)	.06 to .50 in (1.5 to 13 mm)
Weight range of piece	1 to 500 lb (0.5 to 225 kg)	0.5 to 5.0 lb (0.22 to 2.26 kg)
Glass content by volume	50 to 60%	30 to 40%
Length of glass fiber	0.25 in (6 mm) to several inches (mm)	0.06 in (1.5 mm)
Strength	Not uniform throughout	Uniform
Minimum annual quantities	Less than 1000	10,000
Obtain strength from ribs	Not necessarily	Yes
Tooling	Depends on complexity and size	Generally 20 to 30% higher than compression molding
Process	Compression or resin transfer	Injection, cannot use compression molding.

They have an allowable application temperature range of 180–250°F (82–120°C), depending on the material. Examples of thermosets are epoxies and vinyl esters. They can be stronger than thermoplastics but are usually more brittle. Thermosets are processed by comparison molding or transfer molding. They have good chemical resistance to acids, bases, and oxidizing agents.

Table 1 outlines the differences between thermoset and thermoplastic polymers.

### LINED PUMPS

To provide chemical resistance for a metallic pump, it is possible to install a flexible, rigid, or sprayed-on liner inside the pump housing. With a flexible lined pump, a metal casing is made to the design shape and pressure. Then a loose liner is fitted inside the pump housing and bonded to the metal casing with an adhesive. This type of liner can come loose under vacuum conditions. There also can be problems at the termination of the liner to the mating pipe flanges.

A resin used in some lined pumps is PTFE (polytetrafluoroethylene). By itself, PTFE does not have the physical properties needed for a pump housing. When it is supported by a metal housing, however, it provides an excellent lining material due to its outstanding range of chemical resistance at high temperatures.

Rigid pump liners are machined out of plastic stock shapes or molded into a near net shape. The liner is then mechanically compressed between bolted steel plates to provide the support. Such pumps are usually small in size.

A sprayed-on composite lining is made by taking a metal casing of the required pressure rating, heating it, and then spraying the composite material inside the housing and flanges. At 0.030 in (0.76 mm) thickness, the lining will not have pinholes and is suitable for pump applications. This lining process is usually limited to pumps that require up to 100 horsepower (75 kW) drives.

Table 2 gives an overview of the comparative advantages and disadvantages of the different styles of pumps.

### CERAMIC AND CARBON PUMPS

Solid ceramic or carbon pumps are used for very hostile liquids such as concentrated hydrofluoric acid. Ceramic and carbon pumps are much more expensive than non-metallic pump materials, but do have the chemical resistance required for extremely aggressive chemicals.

## TECHNIQUES FOR MOLDING PUMP COMPONENTS

---

Injection molding is a process for high volume forming of high quality thermoplastic parts. The part cost is low, but the initial mold costs can be high. The reinforcing materials for injection molding are short strand fibers (0.06 to 0.50 in or 1.5 to 13 mm long) and are glass, graphite, mica, and so on.

Compression or transfer molding uses thermoset resins and can make small quantities of larger parts. The mold costs are less, but the part price is usually more due to trimming and secondary machining steps. The reinforcing materials for these processes can be continuous or chopped mat strands, as well as woven mats and blankets. These long strand fibers give exceptional physical properties to the final part.

## MECHANICAL PROPERTIES OF COMPOSITES

---

Composites in general have far lower physical properties when compared to steel and lower physical properties than aluminum or brass. Composites can, however, be designed to withstand the operating pressures of a pump by increasing the section modulus of the part; that is, increasing the wall thickness. Table 3 shows some unreinforced composite properties versus steel. Figure 2 illustrates where the various composites and metallic are positioned and applied on a grid of developed pressure versus flow.

**Thermoplastics** PVC and CPVC pumps are low-cost and suitable for the lower temperature ranges. PVC can be used up to 140°F (60°C) and CPVC, with greater abrasion resistance, is suitable for temperatures up to 210°F (100°C). PVC and CPVC can be solvent-bonded together to attain the best attributes of each resin in a single pump.

Polypropylene (PP) has excellent corrosion resistance and is used in hydrocarbon service up to 185°F (85°C). It is not suitable for strong acids or chlorinated hydrocarbons. The material can be ultrasonic, vibration, and spin welded in assembly.

PVDF (Kynar) is very corrosion- and abrasive-resistant and suitable for temperatures up to 300°F (150°C). It is also relatively expensive.

PTFE (Teflon) is extremely corrosion resistant, but its low physical properties require it to have a metal reinforcement backing to withstand high pump pressures. Table 4 is a partial list of thermoplastics used for pump parts.

**Thermosets** Vinyl esters and epoxies are the strongest of the thermoset composites and usually do not require external metal reinforcement. Vinyl esters are resistant to corrosion, whereas the epoxy composites are resistant to solvents. Table 5 is a list of thermosets used for pump parts.

## CANDIDATE FLUIDS FOR COMPOSITE PUMPS

---

This section discusses some of the more general liquids that are suitable for use in composite pumps.

**Chlorine and Caustics** Chlorine is used in the production of organic chemicals such as vinyl chloride, chlorinated solvents, pesticides, and fluorocarbons. Chlorine is also used in the pulp and paper industry, municipal water purification, sewage treatment plants, and in the electrolysis of sodium chloride to produce sodium hydroxide. Additional fluids in this category are as follows:

- Potassium hydroxide
- Sodium chloride solutions
- Seawater, brine

**TABLE 2** Comparative advantages and disadvantages of the different styles of pumps

Feature	Thermoset	Thermo-plastic	Flex-lined	Sprayed-lined	Rigid-lined
Cut impellers available	Yes	Yes	Yes & No	Yes	Yes
Potential for damage to liner in operation or repair	Low	Low	High	High	Low
Integral casing flanges	Yes	Yes	Yes	Yes	No
Efficiency	High	Med	Med	Yes	Med/Low
CPI Hydraulic Coverage	Yes	No	Yes	Yes	No
Conforms to ASME/ANSI B73.1M dimensions	Yes	No	Yes	Yes	No
Cost	Med	Low	Yes	Yes	Med/High
Pressure Capability	Med	Low	High	High	High
Vacuum Capability	Good	Fair	Low	Good	Good
Temperature Capability	Med	Med/Low	High	High	High

**TABLE 3** Mechanical properties of some unreinforced composites

Property/Material	Steel	Glass	Vinyl Ester	PVC	PVDF	PTFE	PPS	PP	PEEK	Epoxy
Modules of Elasticity $1 \times 10^6$ lb/in <sup>2</sup>	29	5	3.5	0.4	0.16	0.8	0.6	0.2	0.6	3.5
Tensile strength $1 \times 10^3$ lb/in <sup>2</sup>	60	300	11	7	7	4	14	6	16	16
Specific gravity	7.8	2.6	1.2	1.3	1.8	2.2	1.3	0.9	1.31	2.2
Coefficient of Thermal Expansion $1 \times 10^5$ in/in/°F	0.6	0.3	2.0	2.8	8.5	10.0	2.8	8.0	4.0	2.2

Lb/in<sup>2</sup>  $\times$  6.894757 = kPa

In/in/°F  $\times$  1.8 = cm/cm/°C



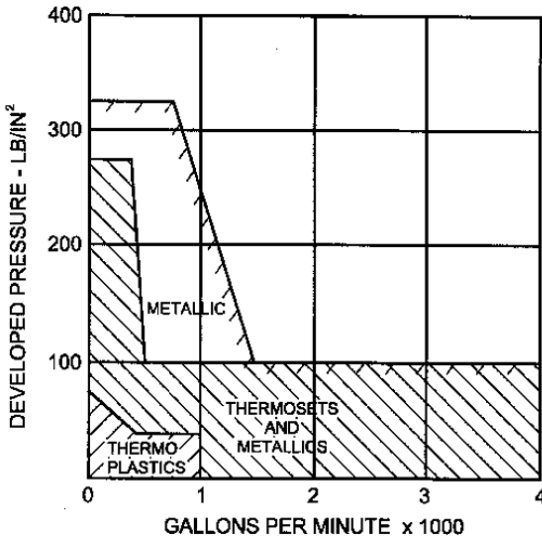


FIGURE 2 Developed pressure versus flow for composite pumps ( $\text{lb/in}^2 \times 0.0689 = \text{bar}$ ;  $\text{gpm} \times 0.227 = \text{m}^3/\text{h}$ )

TABLE 4 Thermoplastics used for pump parts

Chemical name	Common reference	Temperature limit	
		°F	°C
Polycarbonate	Lexon®	250	120
Phenylene Oxide	Noryl®	194	90
Polyphenylene	Ryton®-PPS	250	120
Polyphenylene	PP	150–180	65–82
Chlorinated Polyvinyl Chloride	CPVC	230	110
Polyvinylidene Chloride	PVDC	160	70
Polyvinyl Chloride	PVC	140	60
Polyetherether Keytone	PEEK	250	120
Polytetrafluoroethylene	Teflon®-PTFE	460	238
Chlorotrifluoroethylene	Teflon®	500	260
Polyvinylidene fluoride	Kynar®-PVDF	300	150

TABLE 5 Thermostats used for pump parts

Name	Common Reference	Temperature	
		°F	°C
Vinyl Ester GL	VE-GI	250	120
Vinyl Ester C	VE-C	250	120
Epoxy	Epoxy	250	120

GL—glass reinforced (should not be applied to hydrochloric acid or caustics)  
C—carbon reinforced

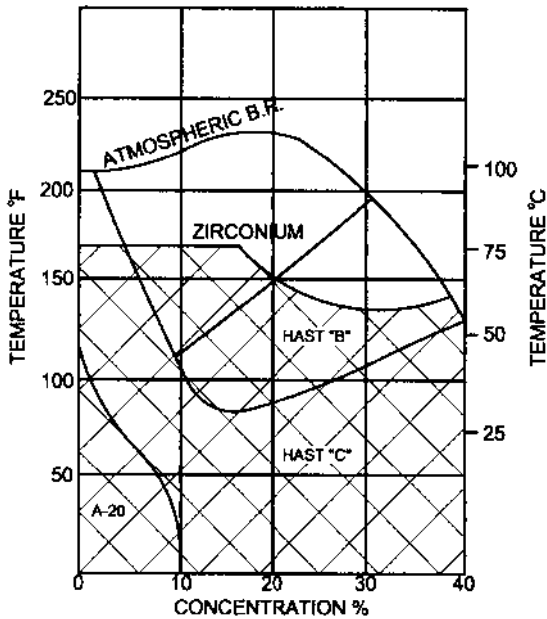


FIGURE 3 Material selection for hydrochloric acid

- Sulfuric acid diluted up to 70%
- Hydrochloric acid
- Sodium hydrochloride
- Nitric acid up to 5%

Figure 3 shows that a composite pump can handle up to a 40% concentration of hydrochloric acid at 175°F (80°C).

**Sulfuric Acid** Figure 4 shows the operating range of a composite pump, pumping sulfuric acid.

**Ferrous and Ferric Chloride** Ferric chloride is used as an etching reagent in the production of printed circuit boards. It is also used as a coagulant in wastewater treatment. In metal pickling operations, ferric is produced when hydrochloric acid reacts with iron and steel. In all of these applications, composite pumps have replaced the more costly titanium pumps.

**Ethylene and Propylene** Candidate applications for composites of ethylene and propylene are

- Propylene glycol
- Ethylene glycol
- Diethylene glycol
- Propylene chlorhydrin

**Dyes** Acid, sulfur, and Diazo dyes can be used in composite pumps.

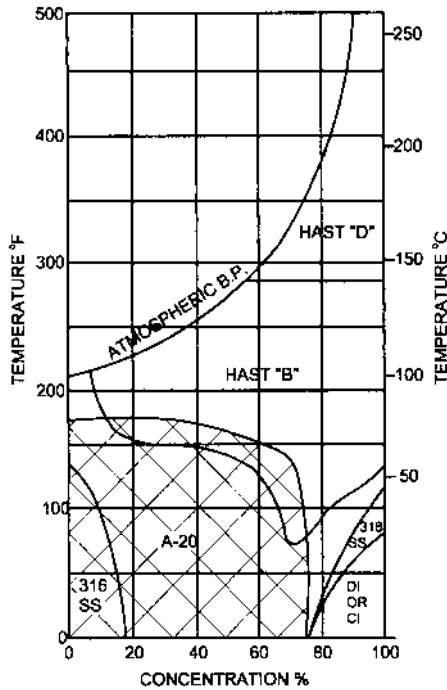


FIGURE 4 Material selection for sulfuric acid

**Agriculture Chemicals** Pesticides comprised of insecticides, herbicides, fungicides, and fertilizers can be severely corrosive to a composite pump. The chemical supplier should be contacted for their recommendations of materials suitable for use with their products.

Table 6 lists the maximum temperature and concentration of several liquids for various polymers.

## INDUSTRIES USING COMPOSITE PUMPS

**Pulp and Paper** Composite pumps are used in bleaching and cooling of liquor preparation. The pumps can handle white, black, and green liquors. Other liquids suitable for composite pumps associated with this industry include

- Sulfuric acid
- Sodium chlorate
- Sodium hypochlorite
- Sulfur dioxide
- Chlorine
- Methanol
- Peroxide bleach
- Sodium chloride
- Chlorine dioxide

**TABLE 6** Maximum temperatures of polymers in various liquids

Type	Fluid	Symbol	Concentration	Vinyl Ester	CPVC	PVC	PVDF	PTFE	ECTFE	PPS	Polypropylene	Epoxy	PEEK
Acids	Hydrochloric Acid	HCl	37	100 (38)	185 (85)	70 (21)	275 (135)	260 (127)	200 (93)	200 (93)	70 (21)	140 (60)	250 (121)
	Sulfuric Acid	H <sub>2</sub> SO <sub>4</sub>	75	120 (49)	140 (60)	70 (21)	200 (93)	500 (260)	300 (150)	80 (27)	125 (52)	NR	NR
	Nitric Acid	HNO <sub>3</sub>	20	150 (65)	185 (85)	140 (60)	140 (60)	250 (121)	200 (93)	150 (65)	140 (60)	70 (21)	NR
Alkalies (Caustics)	Potassium Hydroxide	KOH	45	100 (38)	200 (93)	185 (85)	165 (74)	300 (150)	250 (121)	200 (93)	185 (85)	185 (85)	150 (65)
	Sodium Hydroxide	NaOH	50	210 (100)	200 (93)	NR	200 (93)	300 (150)	200 (93)	160 (71)	185 (85)	70 (21)	150 (65)
5.59	Ammonium Hydroxide	NH <sub>3</sub> OH	20	100 (38)	200 (93)	150 (65)	275 (135)	300 (150)	200 (93)	200 (93)	225 (107)	100 (38)	250 (121)
	Sodium Chloride	NaCl	Sat'd.	210 (100)	200 (93)	150 (65)	275 (135)	400 (204)	70 (21)	200 (93)	225 (107)	210 (100)	250 (121)
	Oxidizers	Sodium Hypochlorite	NaOCl	10	180 (82)	200 (93)	100 (38)	100 (38)	300 (150)	200 (93)	200 (93)	140 (60)	NR
Organics (Solvents)	Hydrogen Peroxide	H <sub>2</sub> O <sub>2</sub>	30	150 (65)	140 (60)	70 (21)	240 (115)	480 (250)	140 (60)	150 (65)	70 (21)	70 (21)	250 (121)
	Benzene	C <sub>6</sub> H <sub>6</sub>	100	100 (38)	NR	NR	125 (52)	390 (200)	200 (93)	200 (93)	NR	NR	250 (121)
	Styrene	CH <sub>5</sub> CH:CH <sub>2</sub>	100	120 (49)	NR	NR	ND	200 (93)	ND	120 (49)	NR	140 (60)	250 (121)
	Ethyl Alcohol	C <sub>2</sub> H <sub>5</sub> OH	95	100 (38)	140 (60)	70 (21)	210 (100)	390 (200)	300 (150)	200 (93)	140 (60)	70 (21)	250 (121)

Corrosion resistance of common polymers in difficult process fluids. Max. recommended temperature—deg. F (deg. C)

NR = Not Recommended

ND = No Data Available

- Sodium hydroxide
- Hydrochloric acid

**Metal Finishing** Composite pumps are an excellent choice for use in this industry for two reasons:

- The chemicals used in electroplating, steel pickling, etching, anodizing, galvanizing, and plating do not chemically attack composites.
- Metal pumps can generate stray currents and could effect the plating process.

Composite pumps are natural electrical insulators, which makes them well suited for this industry.

**Desalinization and Water Purification** Composites can replace 316 stainless steel, duplex stainless steel and Alloy 20 on sea water distillation plants. On reverse osmosis equipment, composite pumps can be used for backwash, membrane blowdown, and intake screen wash.

**Aqua Culture** Composite pumps can be used for waste removal, seawater transfer, washdown, and filtering without adversely affecting sea life. This adverse reaction can occur with metal pumps. Metal pumps can have a chemical reaction with seawater and stray electrical currents generated by the pump can affect the pump's mechanical seal.

## STANDARDS FOR COMPOSITE PUMPS

---

There are many composite pump designs for low-pressure and low-capacity use in the general-purpose market. For composite pumps in the "industrial chemical market," however, a separate standard ANSI/ASME B 73.5M has been written. This standard is similar to B73.1M for metal pumps in that it requires the same dimensional interchangeability, shaft deflection, and seal chamber requirements. The composite pump standard differs from the metallic pump standard in these areas:

- Basic working pressure is from 100 to 275 lb/in<sup>2</sup> (6.9 to 19 bar) depending on pump size.
- Nozzle flanges are Class 150 dimensions but not Class 150 rated.
- Hydrostatic pressure factor above working pressure will depend on size, rpm, and manufacturing process.
- Pressure-temperature limit will be based on a manufacturer-user agreement for the liquid and its concentration.
- The standard applies to both thermoplastic and thermoset composites.
- Casing, casing cover, and gland have a minimum corrosion allowance of two years.

**Hydraulic Institute Material Selection Guide** A material selection guide has been written with recommendations of what composite should be used with what type of liquid. This guide lists 150 liquids at various concentrations and temperatures and recommends suitable composites for applications. See References and Further Reading at the end of this section.

## PUMP CONSTRUCTION

---

The pump section views in Figures 5 to 8 illustrate the construction of some composite pumps.

**Components** Figure 9 shows various pump components made from both thermoplastic and thermoset polymers. The enclosed impellers are made of thermoplastic resins

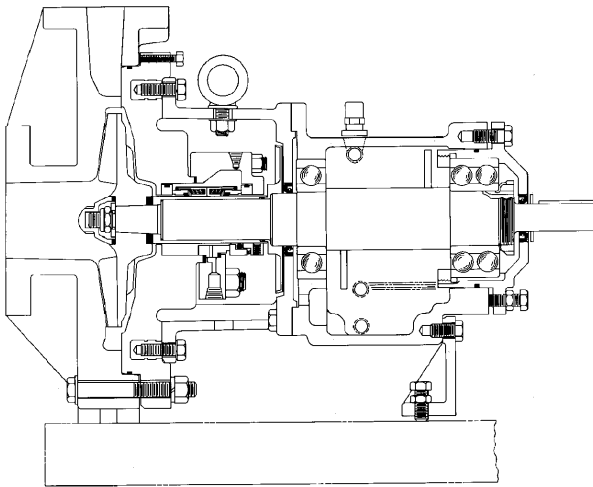


FIGURE 5 ANSI/ASME B73.5M pump (Flowserve Corporation)

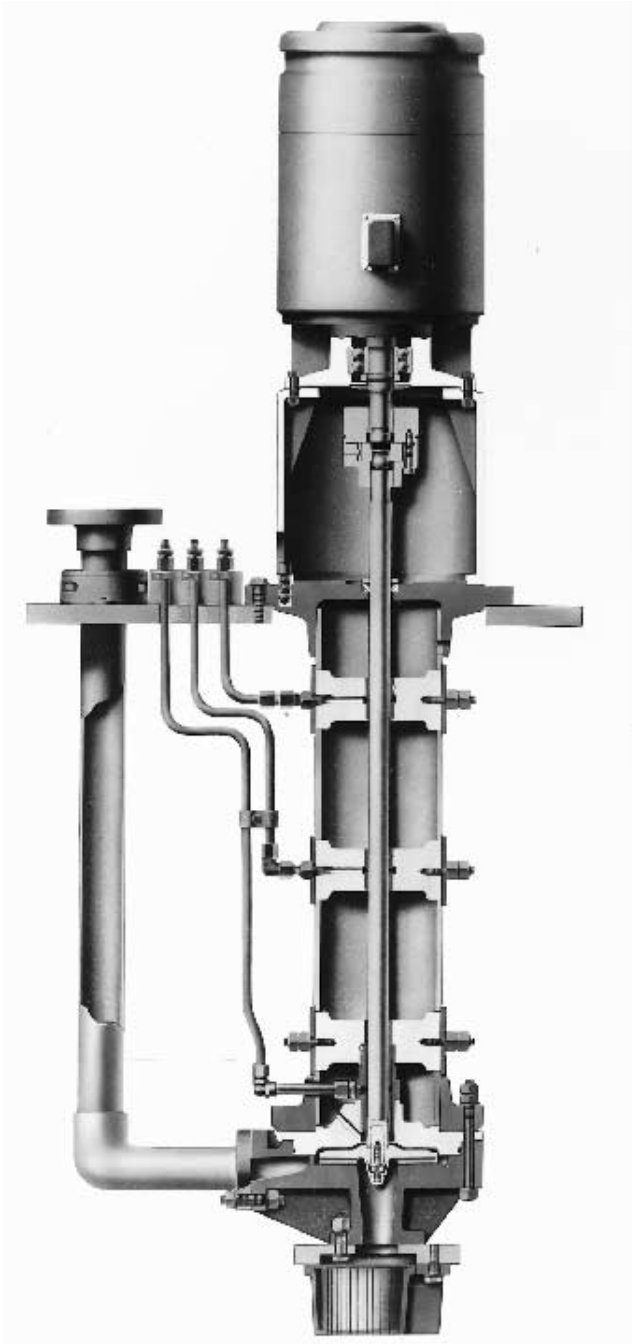
because the front and back shroud can be ultrasonic- or vibration-welded together. Semi-open impellers can be made of either type of composite. On sizes greater than 6 in (152 mm) diameter, thermosets are usually used due to their superior strength over thermoplastics. When thermoplastics are used in larger impellers, a metal reinforcing skeleton is used for reinforcement. Casing and casing covers are made of either composite depending on the pump size and pressure rating.

The seal between the casing and cover is usually a shaped “O-ring” held by a groove running around the perimeter of the casing. The “O-ring” is compressed between the casing and cover with a ring of bolts around the casing’s perimeter.

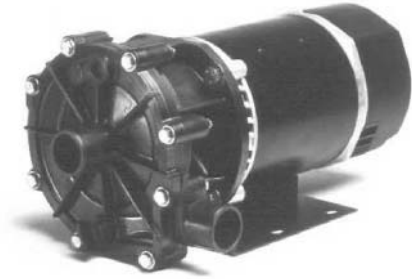
Shafts are made of AISI 4140 or 316 stainless steel with a thermoplastic shaft sleeve for corrosion protection. Mechanical seals are of “outside” construction to prevent liquid from contacting the metal portion (springs) of the seal.

**Bedplates** Composite materials have several advantages over metals and other materials when used for bedplates. Composites do not rust, rot, or deteriorate in adverse environments. The composite bedplate maintains its shape over time. This assures that the pump shafts will stay in alignment, and the pump’s nozzle will not be stressed due to a sagging bedplate. The designed in features in a composite bedplate include an integral drip lip, slopping surface to collect drips, and ringed grout holes.

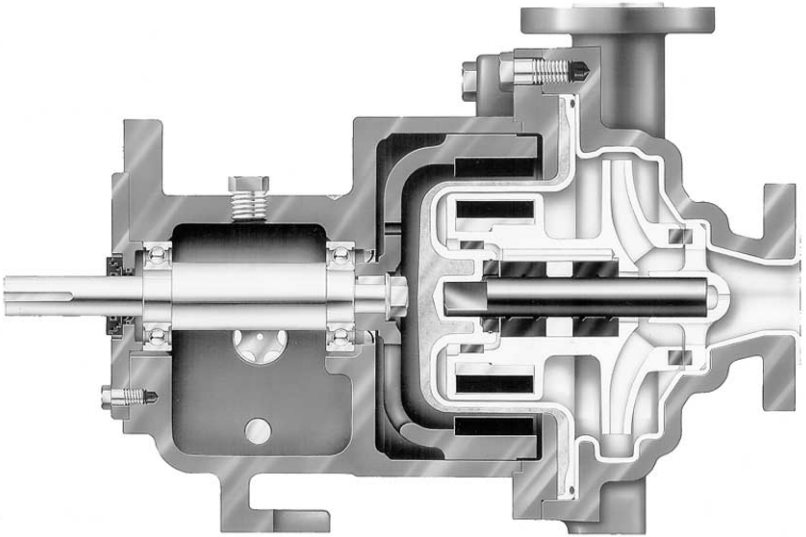
**Disclaimer** The data and notes included in this section are only for general guidance. No recommendations are intended as a guarantee by the author or other sources. Pump manufacturers and material suppliers can supply specific application information for their products when used with specific liquids in identified services and environments.



**FIGURE 6** Vertical immersion pump (Flowsolve Corporation)



**FIGURE 7** Thermoplastic coolant pump (Flowserve Corporation)



**FIGURE 8** Fluoropolymer sprayed lined ANSI/ASME B73.3 pump (Goulds Pumps)





FIGURE 9 Components made of thermoset (Flowserve Corporation)

## REFERENCES AND FURTHER READING

American Society of Mechanical Engineers. "Specification for Thermoplastic and Thermoset Polymer Material Horizontal End Suction Centrifugal Pumps for Chemical Process." ASME B73.5M-1995, New York.

American National Standard for Pumps—General Guidelines for Types, Definitions, Application, Sound Measurement, and Decontamination, ANSI/HI 9.1-9.5-2000, Section 9.3.3, Common Polymer Materials of Construction for Various Liquids, Hydraulic Institute, Parsippany, NJ [www.pumps.org](http://www.pumps.org).

Besic, D. "Spotlight on Plastics." *Pump and Systems Magazine*, October 1994, Fort Collins, CO.

Buse, F. W. "Tutorial on Composite Pumps." Proceedings of the 11th International Pump Users Symposium. March, 1994, Texas A&M University, College Station, TX.

Fusco, J. "Plastic Developments Advance Pipe Performance and Safety." *Chemical Processing*, December 1990.

Henning Kausch, H. "Advanced Thermoplastic Composites." Hanser Gardner Publications, 6915 Valley Ave., Cincinnati, OH, 1992.

Lin, S., and Pearce, E. M. "High Performance Thermosets," Hanser Gardner Publications, 6915 Valley Ave., Cincinnati, OH, 1993.

Margus, E. "Choosing Thermoplastics Pumps." *Chemical Engineering*, July 1991, McGraw-Hill, New York.

*Modern Plastics Encyclopedia '99*. The McGraw-Hill Companies, Inc., Highstown, NJ, 1998.

Plastics Technology Manufacturing Handbook. Bill Communicators Inc., 355 Park Ave., South New York, NY, 1998.

Rosato, D. V., DiMattia, D. P. "Designing with Plastics and Composites—A Handbook." Van Nostrand Reinhold, New York, 1991.

### ***Internet Resources***

*Injection Molding Magazine's* listing of books: <http://www.immbookclub.com>

Plastic technology consulting source: <http://www.rapra.net/intro.htm>

Listing of plastic resources and issues: <http://www.polysort.com>

C • H • A • P • T • E • R • 6

# **PUMP DRIVERS**

---

# SECTION 6.1

---

# PRIME MOVERS

---

## 6.1.1

### ELECTRIC MOTORS AND MOTOR CONTROLS

A. A. DIVONA  
A. J. DOLAN  
J. R. HENDERSHOT

The two most common types of electric motors are *alternating current (ac) induction* and *direct current (dc) commutated shunt- or series-wound*. All electric motor configurations except one type (reluctance brushless) convert electrical energy to mechanical energy from the magnetic flux linkage of their two magnetic circuits. One of these circuits is in the stator and the other is in the bearing-mounted rotor. This flux linkage between the two magnetic circuits produces a moment of force at the rotor radius that results in a torque on the motor shaft causing shaft rotation. The speed of the rotation times the torque equals the output power at the motor shaft. This is, of course, the power used to drive a pump.

The basic difference between these two types of electric motors has to do with their electrical power source. The first type has been historically powered by 60 cycle (Hz) alternating voltages direct from the public utility power grid (50 Hz in most of Europe and some other parts of the world). For this type of motor, the speed is determined by the number of magnetic poles designed in the motor and the alternating sinusoidal frequency of the voltage from the power grid. Methods have been developed to alter the speed of an ac motor with a fixed number of poles and a fixed line frequency (it is also possible to wind such a motor with several poles for other speeds). However, the squirrel-cage induction motor remains without question the most common type of motor used to drive pumps. The reasons for this are worldwide availability, excellent reliability, excellent performance characteristics, and ease of replacement. As the pump industry continues to adopt variable speed motor/drives, the ac induction motor will likely continue to be by far the number one prime mover for most all types of pumps. This is also because of its adaptability to variable speed using ac inverters and vector drives.

The other motor type currently in use to drive pumps is the dc motor. Most of these applications are in the smaller sizes such as automotive and off road equipment. The overall use of dc motors for pump drives is predicted to decline.

The dc type of electrical machine also contains two magnet fields, one in each of the stator and rotor assemblies of the motor. Although the dc motor does not operate for its entire

useful life without maintenance on the mechanical brushes and commutator, it is still selected for some pump applications when only a dc voltage power source is available. It has been also selected in a limited number of instances where adjustable speed is required. The dc motor, powered by the voltage from storage batteries or from a dc generator, can be speed-adjusted by varying the voltage with a power supply. Its speed relationship to the voltage is linear and very useful for some pump applications such as constant displacement types, which require speed adjustment to set flow. [See Subsection 6.2.2.]

The more recent availability of permanent magnet brushless dc motors should offer a more reliable prime mover for these applications, with superior performance and long life benefits.

There are other types of electric motors considered for driving pumps. The reasons for this include the dramatic recent advances in power electronics and microprocessors, advances in motor materials such as permanent magnets, and advances in the pumps themselves. Besides the active interest in adjustable speed pumps, another reason for the interest in some newer motor types for pump applications is because of recent U.S. government regulations enacted to improve energy conservation by implementing motor efficiency mandates along with a time schedule. For example, the *U.S. Energy Policy and Conservation Act* of September 10, 1992 (*EPACT*) stipulates that all covered electric motor products must meet the efficiency levels per NEMA MG1 1993. The requirement covers all electric motors from 1–200 horsepower (1–150 kW) manufactured after October 24, 1997 that operate from 230/460 VAC power at 60 Hz line frequency. The U.S. Department of Energy approved test method to meet the new efficiency levels is per IEEE-112B. This regulation was originally intended for ac induction motors.

For those pump applications that require the motor torque to increase as the square of speed, these new, more efficient motors will run at higher speeds because their slip is less. This could cause an appreciable increase in overload within the motor. Overload could also result in other mechanical parts of the system. There are other ramifications resulting from these new requirements that must be carefully analyzed when selecting an electric motor, starter, or inverter. The resulting analysis might very well cause the selection to be some other electric motor type, such as a permanent magnet brushless dc, permanent magnet ac, synchronous (sine wave driven version of the brushless dc), or even a switched reluctance brushless dc motor. Each of these types must be powered with an inverter and a controller. However, the result can most likely offer adjustable speed with a very high efficiency over a wide speed range. This use of an inverter is required for each of those other types of motors mentioned. With the availability of the new vector controlled ac inverters (Section 6.2.2), the high-efficiency ac induction motor can also be applied for variable speed. This will eliminate the need for a soft starter frequently required with line fed motors. The elimination of the starter helps somewhat to offset the additional cost of the inverter.

## TYPES OF MOTORS

---

### Alternating-Current Motors

**SQUIRREL-CAGE INDUCTION MOTOR** By far the most common motor used to drive pumps is the squirrel-cage induction motor (Figure 1). This motor consists of a conventional stator wound with a specific number of poles and phases, and a rotor that has either cast bars or brazed bars imbedded in it.

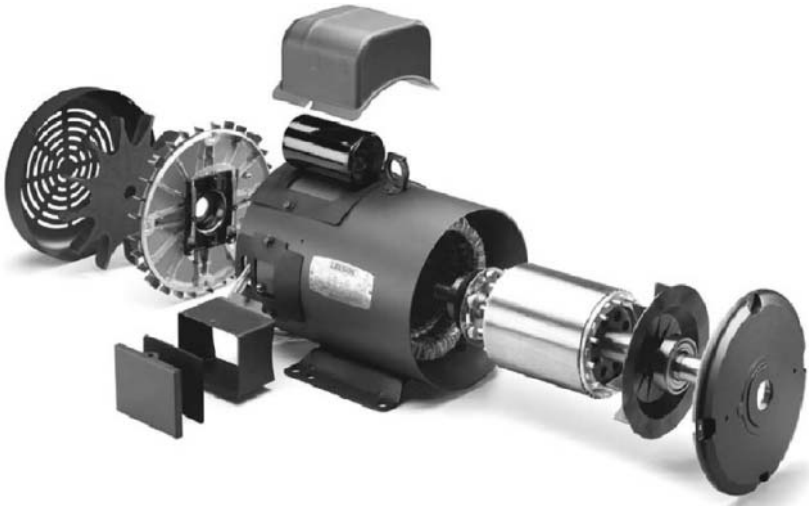
The squirrel-cage induction motor operates at a speed below synchronous speed by a specific slip or revolutions per minute. The synchronous speed is defined as

$$N = \frac{f \times 60 \times 2}{p}$$

where  $N$  = speed, rpm

$f$  = line-power frequency, Hz

$p$  = number of poles



**FIGURE 1** Exploded view of a typical squirrel-cage induction motor (Courtesy of Leeson Electric Corp.)

The percent slip is defined as

$$\% \text{ slip} = \frac{(N - s) \times 100}{N}$$

where  $s$  = slip, rpm

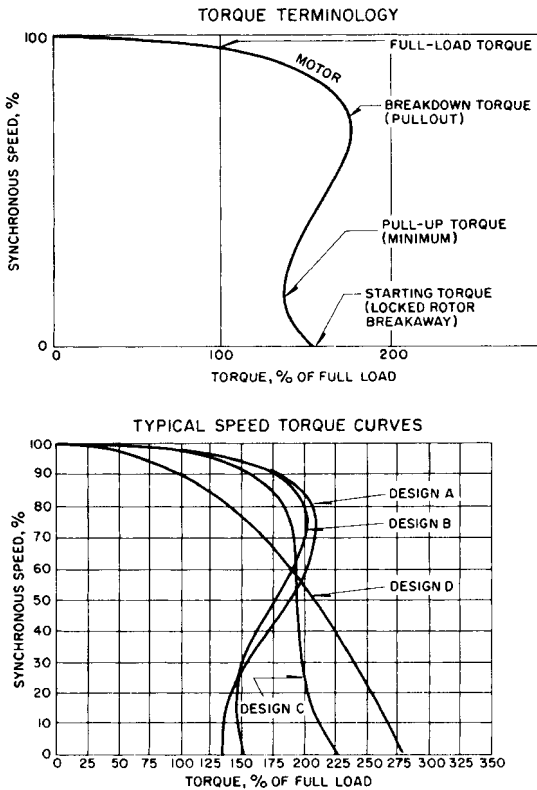
When the stator winding of a squirrel-cage induction motor is connected to a suitable source of power, a magnetic flux is generated in the air gap between the stator and rotor of the motor. This flux revolves around the perimeter of the air gap and induces a voltage in the rotor bars. Because the rotor bars are short-circuited to each other at their ends (end rings), a current circulates in the rotor bars. This current and the air-gap flux interact, causing the motor to produce a torque.

The squirrel-cage induction motor exhibits a characteristic speed-torque relationship that is determined by the resistance of the rotor bars. Thus, the desired speed-torque characteristics are obtained by selecting a metal of suitable resistance when designing the rotor bars. The slot shape and size for the bars in the rotor can be selected to achieve a certain rotor resistance.

Figure 2 suggests several typical speed-torque characteristics that have been standardized by NEMA (National Electrical Manufacturers Association), covering motor frames 143T through 449T. Motors larger than 449T may not have these same values, but generally have the same characteristic curves. Also, single-phase motors may not exhibit these characteristics and are defined specifically by NEMA with different values.

Most pumps are driven by NEMA B characteristic motors when operated from three-phase power sources.

**WOUND ROTOR INDUCTION MOTOR** The wound-rotor induction motor is in every respect similar to the squirrel-cage version except that the rotor is wound with insulated wire turns and this winding is terminated at a set of slip rings on the rotor shaft. Connections are made to the slip rings through brushes and in turn to an external resistor, which can be adjusted in ohmic value to cause the motor speed-torque characteristics to be changed. These types of motors have been used in some pump applications in the past, but due to



**FIGURE 2** These curves are characteristic of NEMA frame size squirrel-cage induction motors through size 449T (typically through 300 hp–224 kW).

the availability of inverter-fed ac squirrel-cage induction motor drives, they are no longer very practical.

Figure 3 demonstrates the speed-torque characteristics of a wound-rotor induction motor for several resistor values. It will be noticed that increasing the external resistance of the control will cause the peak torque of the motor to be developed at lower speeds until the peak torque occurs at zero speed. Increasing the resistance beyond this value will cause the motor to have a limited torque as, for example, curves 4, 5, and 6. This motor can be used where torque control is required or where variable speed is necessary. In the variable-speed application, the rotor resistance is adjusted to produce a motor torque that matches the load torque at the specific speed desired. This system is not as useful and cost-effective as an inverter-fed ac induction motor due to the recent developments of power electronics and microprocessors.

**SYNCHRONOUS MOTOR** The synchronous motor is also similar to the squirrel-cage induction motor except that it operates at synchronous speed and its rotor is constructed with definite salient poles on which a field coil is wound and connected to a source of direct current for excitation. The most common synchronous motor is constructed with slip rings on the rotor shaft to connect the dc excitation to the field coils.

There are various means of providing the dc power to the slip rings:

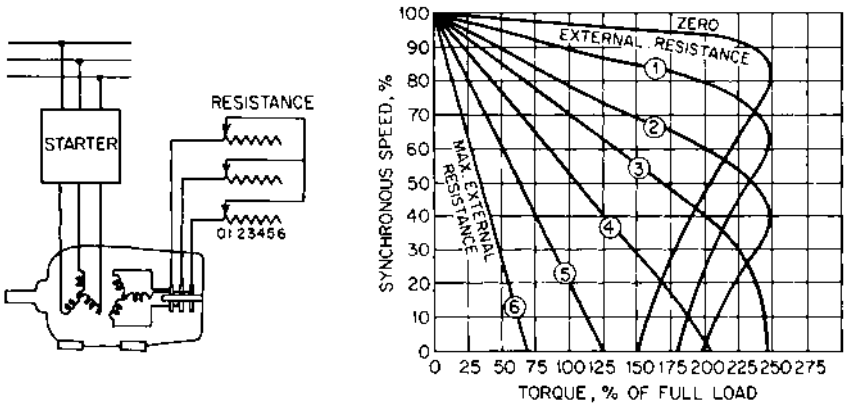


FIGURE 3 Typical speed-torque characteristics of a wound-rotor induction motor (Westinghouse Electric)

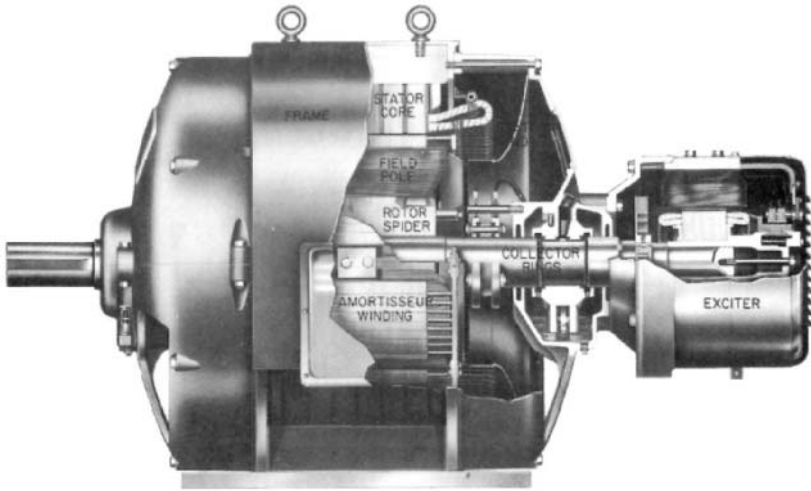
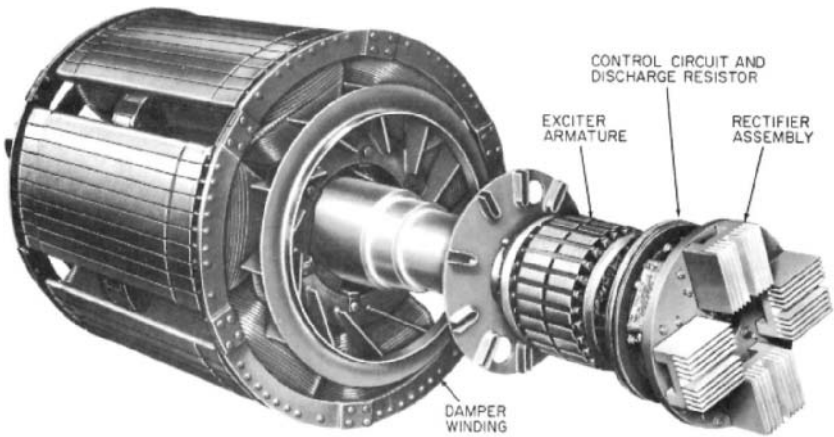


FIGURE 4 Synchronous motor with direct-connected exciter (Electric Machinery Manufacturing)

1. **Static excitation** The power to be connected to the slip ring brushes on the motor shaft is obtained from a transformer and rectifier package external to the motor.
2. **Direct-connected exciter** This arrangement has a dc generator directly connected to the synchronous motor shaft (Figure 4). The dc power from this generator is connected to the brushes of the synchronous motor slip rings.
3. **Motor-generated exciter** The dc power for exciting the synchronous motor is generated by means of a remote motor-generator set operating from normal ac power, and the dc voltage from this motor-generator set is connected to the brushes of slip rings of the synchronous motor.

Another form of synchronous motor is known as the *brushless synchronous motor* (Figure 5). As the name implies, this motor has its rotating field excited without the use of slip rings for connecting the external direct current to the motor field. The construction of this





**FIGURE 5** Brushless synchronous motor with ac generator mounted on the shaft with rectifier and control devices (Electric Machinery Manufacturing)

motor incorporates a shaft-connected ac generator. The field of the ac generator is physically stationary and connected to a source of dc voltage. The rotor of this ac generator is connected through a solid-state controlled rectifier mounted on the synchronous motor rotor and in turn connected to the synchronous motor field. This arrangement facilitates a connection between external excitation power and the rotating field of the synchronous motor through the air gap of the shaft-connected ac generator. The brushless synchronous motor has many advantages over the conventional slip-ring synchronous motor. Among these are the elimination of brushes and slip rings, which are high-maintenance items; the elimination of sparking devices, which are not permissible in certain atmospheres; and the use of static devices for field control, which are more reliable than conventional electromagnetic controls.

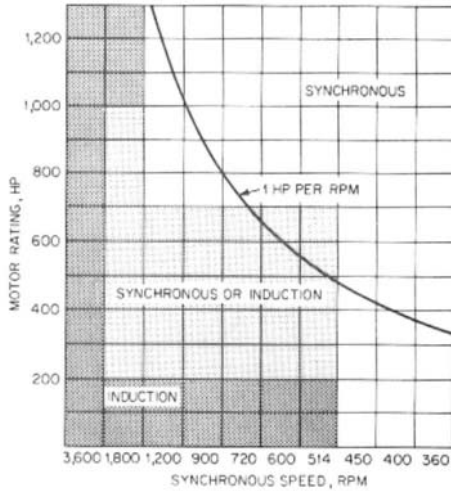
Synchronous motors are used for pump applications requiring larger horsepower ratings at lower speed conditions, as illustrated in Figure 6. Also, they are used on applications where a high power factor or a power-factor-correction capability is desired. Of less importance is the characteristic of the synchronous motor that it will always operate at synchronous speed (does not have a slip) regardless of load. Synchronous motors are started on their damper windings (the same as squirrel-cage induction motors), and when they have accelerated to within 5% of synchronous speed, the field is applied and the motor accelerates to synchronous speed (Figure 7). Typical characteristic curves are shown in Figure 8.

**Direct-Current Motors** Dc motors are only occasionally used to drive pumps. Most of the current applications for dc pump drives are in some form of automobile or off-the-road equipment due to the dc power from storage batteries. There are some other situations that might call for dc motor pump drives such as shipboard duty, railway applications, aircraft, mining installations, and some other emergency battery operations.

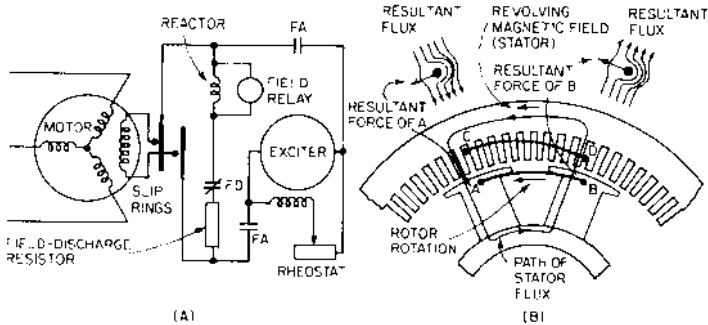
There are three types of dc motors available (Figure 9): shunt, series, and compound-connected.

Larger horsepower ratings of shunt-wound dc motors are frequently qualified as “stabilized shuntwound” motors and incorporate a series field similar to that of a compound wound motor. This is necessary to adjust the regulation of the shunt motor so as not to exhibit a rising speed-torque characteristic. It is important to be aware of the speed at which a dc motor will operate on pump applications because of pump performance guarantees.

The windings in the stators of the wound types are connected to the armature windings through brushes and a commutator three different ways to achieve different performance

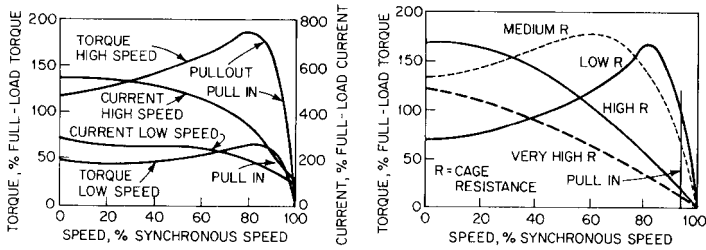


**FIGURE 6** Below 514 rpm, or powers greater than approximately 1 hp/rpm (0.746 kW/rpm), synchronous motors are a better selection than squirrel-cage induction motors because higher cost can generally be offset by higher power factor and efficiency (from *Power* special report, "Motors," June 1969).

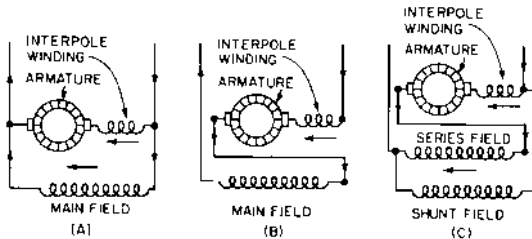


**FIGURE 7** Method of starting synchronous motor. (A) Typical field control (brush type) energizes the dc field to pull the rotor into synchronism as it comes up to speed. Field relay senses change in induced frequency as motor speeds up. (B) Damper winding is similar to a squirrel-cage rotor winding. It produces most of the starting torque, and the synchronous motor starts with essentially induction-motor characteristics (from *Power* special report, "Motors," June 1969).

characteristics (see Figure 3 for details). With the use of pulse width modulation (PWM) or silicon-controlled rectifiers (SCR), variable dc power supplies the armature voltage, which can be controlled along with a separate control for the field current (see Subsection 6.2.2). Using this control scheme, the dc motor can be used to control speed over a very wide range in a smooth manner. For example, constant voltage can be produced from zero rpm up to base design speed of the motor by armature control and constant power above base speed using flux weakening of the armature field. When operating from a constant voltage, dc motors are available to provide up to a 4 to 1 speed range with an adjustable dc field power supply. With this separate control scheme for both field and armature, a 100 to 1 speed range is easily achievable. Figure 9 summarizes the various field connection



**FIGURE 8** Characteristics of synchronous motors depend on rotor design. Torque and current relations are influenced by synchronous speed. High-resistance cage produces high starting torque but low pull-in torque (from *Power* special report, "Motors," June 1969).



**FIGURE 9A through C** Types of dc motors. (A) Shunt motor has field winding of many turns of fine wire connected in parallel with the armature circuit. The interpole winding aids commutation. (B) Series motor has field in series with the armature. Field has a few turns of heavy wire carrying full-motor current flowing in the armature. (C) Compound motor has both a shunt and a series field to combine characteristics of both shunt- and series-type motors in the same machine (from *Power* special report, "Motors," June 1969).

schemes for dual wound dc machines with mechanical commutation systems. Figure 10 illustrates typical characteristics of the dc motors discussed. Figure 11 shows the equivalent circuit of a permanent magnet type dc motor.

**Permanent Magnet (PM) Brushless Motors** The permanent magnet brushless dc motor has been in existence for about three decades and is finally being widely used for many applications. Its being brushless has frequently been mentioned as justification for its cost, higher than most other motor types. However, the PM brushless motor has two other features that are arguably more important than the fact that it contains no mechanical brushes and commutator for commutation of the phase windings to the power source. First, it produces the highest continuous output power per unit volume of any motor yet invented. The other important virtue of a PM brushless motor is that it produces its output power with the least input power. For a given size and output performance envelope, it has the most efficient motor of any electric motor yet invented. With the emphasis on reducing power consumption, this type of motor will be used in many pump applications. In addition, and perhaps most importantly for the application of pumps, the PM brushless motor possesses one other very important feature or use of the permanent magnets contained within the rotor assembly. Although the magnets are there to supply a magnetic field from the rotor to pass through the air gap of the motor into the stator, these same magnets can serve as a magnetic coupling. If a sleeve-shaped liquid barrier made of a suitable material to be impervious to the liquid is fitted between the rotor and stator, the PM brushless can be used as the best hermetically sealed wet motor known. There are, of course, many possible configurations of this PM brushless hermetic motor concept. These PM brushless hermetic motors can be configured as axial gap, radial gap inside

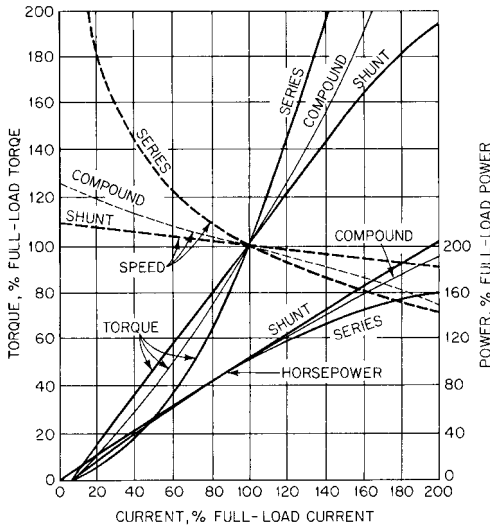
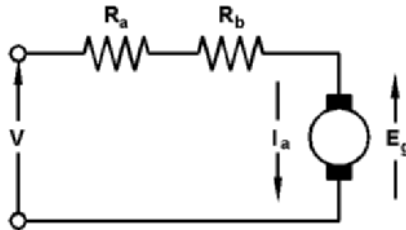


FIGURE 10 Speed, torque, and power characteristics of dc motors (from *Power* special report, "Motors," June 1969)



**V** = Terminal voltage, volts  
 **$R_a$**  = Armature resistance, ohms  
 **$R_b$**  = Resistance of the brushes, ohms  
 **$I_a$**  = Amature current, amperes  
 **$E_g$**  = Back-EMF, volts

FIGURE 11 The equivalent circuit of a dc motor with a permanent magnet stator

rotor, or radial gap outside rotor motors (Figure 12). The choice depends upon the best way to design the pump integration.

All PM brushless motors must be powered with an electronic inverter and controller, which can be used for controlling pump performance in controlled loop systems of all types. The electronic drive can be a simple square wave, a six-step trapezoid type, or a sinusoidal drive. Also, some sort of electronic remote or motor mounted shaft position system that is no different than that used for an ac induction vector drive is required.

Three permanent magnet choices can be used for these motors. The lowest priced magnet material is known as ferrite or ceramic with a magnetic flux output of about one-third

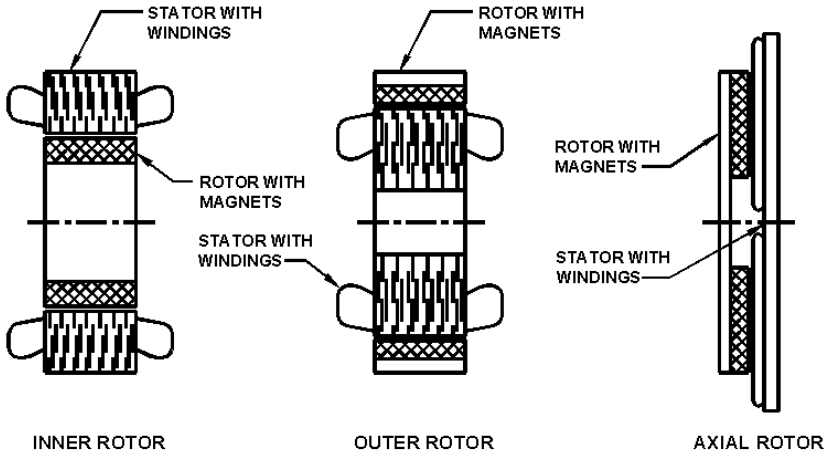
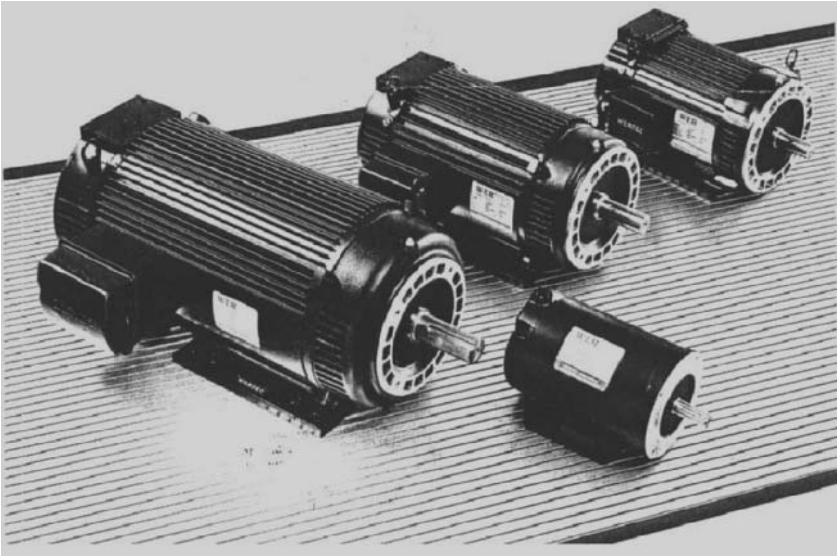


FIGURE 12 Inner, outer, and axial rotor PM brushless motor choices for pump drives

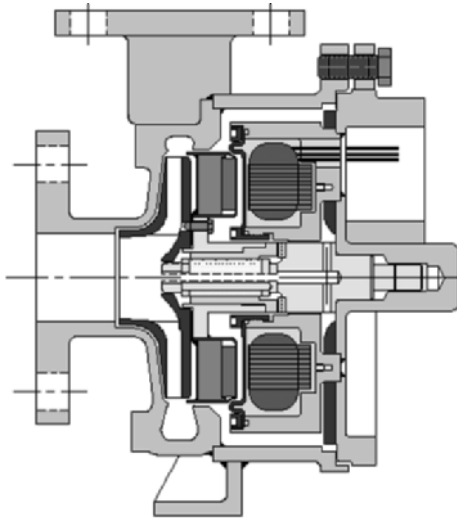
to one-half of the other two magnet choices. By careful design, this magnet material can be used for 50 hp (37 kW) and up in PM brushless machines to keep costs competitive with other machine types. For brushless motors less than 50 hp (37 kW), the two high energy or rare earth magnet grades are frequently useful. The more expensive of the two, Samarium Cobalt, is used for high temperature and other hostile environment pump motor applications. The newer rare earth magnets, known as Neodymium Iron Boron, are much lower in cost, with the highest useful magnetic flux at moderate operating temperatures. Either the magnets can be assembled onto the surface of the rotor or they can be imbedded within the laminated rotor structure. In either design, the rotor can be made to be quite robust and yield a very long useful operating life. In fact, the only failure modes for PM brushless motors have to do with bearings or winding insulation. Figure 13 shows examples of large PM brushless motors.

The speed can be controlled to greater than 100 to 1 if required with constant power over the highest speed range of any other motor type. The efficiency remains very high over the entire speed range. There are many design possibilities including axial gap and outside rotor configurations. For example, because of the high magnetic strength of the permanent magnets, the rotor of a PM brushless motor can also serve as the impeller of a pump that is integrated with the motor in a hermetically sealed package with no shaft seals. Utilizing the axial-gap rotor configuration of Figure 12, the concept is illustrated in Figure 14. Commercially significant impeller torque levels can be generated by the PM brushless motor in this configuration<sup>1</sup>. This eliminates the need for a separate magnetic coupling or larger-size canned induction motor (see the discussion at the end of this section and in Section 2.2.7).

The PM brushless motor can be driven with either square wave currents over a 120 degrees electrical commutation angle or with sinusoidal currents over 180 degrees electrical commutation angle. The latter scheme generally yields lower torque fluctuations, which is sometimes important for pump applications. Either drive requires shaft angle feedback data to tell the phases when to be powered. This feedback data is also a requirement for vector driven ac induction motors. The sensor used for this feedback can be as simple as *Hall* switches mounted in the motor that send out a pulse to the controller each time a rotor magnetic pole changes polarity as the motor rotates. An optical encoder or a *resolver* can also be used for this purpose. Several sensorless or remote sensors have been developed that capture the rotor angle location from the stator phase windings so a shaft-mounted sensor is not required.



**FIGURE 13** Large horsepower (kW) high-performance permanent magnet inside rotor brushless motors (courtesy of Pacific Scientific)



**FIGURE 14** Permanent magnet brushless motor integrated into a seamless pump. Permanent magnets are mounted on the impeller, which serves as the rotor of the motor. (Courtesy of Flowserve Corporation)<sup>1</sup>

**Switched Reluctance Brushless Motor** The SR brushless dc motor is one of the oldest motors known, but it has not been used much until recently. Its main feature is that it is a true brushless motor with most of the virtues of its PM cousin, but it does not require permanent magnets. This feature is a great benefit for the PM brushless motor when it is used in a hermetic pump application. However, the PM brushless motor is limited in the availability of practical sizes because of the cost of permanent magnets. As the

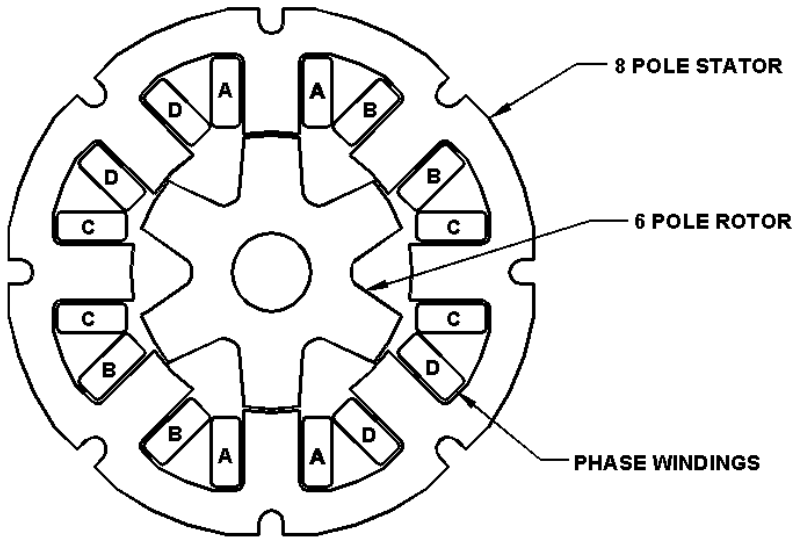


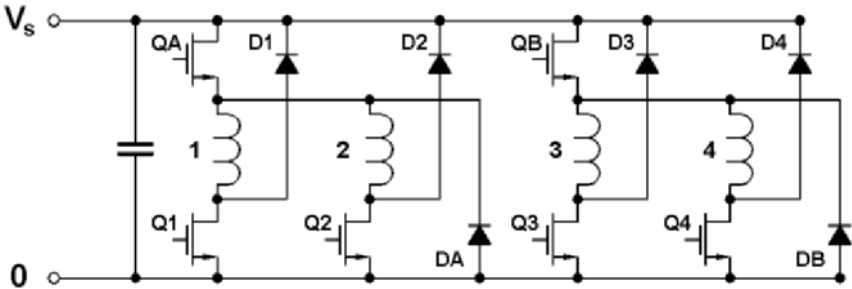
FIGURE 15 Switched reluctance brushless dc motor, (6) rotor poles, (2) stator poles per phase

PM motor gets larger in power and frame size, the cost of the magnets becomes prohibitive. The ac induction motor is still a very good choice for most high-power applications, even when adjustable speed is needed. However, as centrifugal high-speed pumps gain popularity, the ac induction motor has difficulty surviving the forces on the rotor. Proponents of switched reluctance motors point out its inherent robustness. The rotor of the SR motor is so simple and rugged it can survive very at high speeds as well as in a variety of other unusual environmental conditions. Figure 15 shows the typical cross section of a switched reluctance motor, illustrating how simple this motor is with phase coils placed around the stator poles. The rotor consists of a set of magnetic steel gear-shaped laminations taken from the bore of the stator laminations. They are stacked and retained on the motor shaft. No magnets or windings of any kind are required to produce torque. The SR motor is said to be a doubly salient pole machine. The torque is produced by the magnetic attraction of the closest rotor poles to those stator poles which are magnetized by the phase coils. There is an abundance of technical information regarding the performance details of this technology. The important point is that the SR motor is an excellent choice for high-speed high-powered centrifugal pumps.

There is a considerable difference in the inverter topology for the SR motor as compared to either the PM brushless or the ac induction motor. The SR machine must be driven as a unipolar machine rather than a bipolar motor like the other two. This means the standard ac inverter cannot be used for the SR motor. The phases are each connected to the dc power in parallel rather in the standard bridge fashion with all of the phases connected together at a center tap. Figure 16 shows the normal power circuit for the (4) phase SR motor shown in Figure 15. The same circuit is applicable for both two phase or three phase. It is essentially an independent half bridge circuit for each phase. Certain two phase designs are very cost effective for high speed pump drives that are required to rotate in only one direction without the need for reversing.

## MOTOR ENCLOSURES

Electric motors are manufactured with a variety of mechanical enclosure features to provide protection to the working parts for specific environmental conditions. Although these



**FIGURE 16** Power control circuit for (4) phase SR motor, (6) transistors, (6) diodes, (3) current sensors, (1) capacitor, and (6) motor lead connections

special enclosures are classified, they are not, for reasons of economy, available for all size motors. The electric motor industry has incorporated a number of specific enclosure classifications on standard designs of small- and medium-size motors.

The following list describes the motor enclosure specifications available for polyphase ac induction motors used with pumps. This availability depends on demand. Furthermore, the PM brushless and SR brushless motors might not be available in some of the enclosures listed. In general, totally enclosed motors are required for most integral horsepower (kilowatt) pump applications regardless of the motor type. In some instances, such as high-speed centrifugal pumps with integral motors, the motor is furnished to the pump manufacturer as a rotor and stator parts kit. The motor is then included in the pump enclosure.

**OPEN** This enclosure permits passage of external cooling air over and around the windings and rotor of a motor and normally includes no special restrictions to ventilation other than those that are inherent in the mechanical parts of the motor. Most designs include openings at each end of the motor frame either in the bearing end frame or openings around each end of the frame.

**OPEN DRIPPROOF** This is an open machine with ventilating openings designed to permit satisfactory operation when liquids or solids fall on the machine at any angle up to 15° from the vertical. Openings are normally in the bottom portions of the frame assembly. This construction includes mechanical baffling to prevent materials from entering the machine within these limits.

**SPLASHPROOF** This is an open machine with ventilating openings designed to permit satisfactory operation when liquids or solids fall *directly* on the machine or come toward the machine in a straight line at any angle up to 100° from the vertical.

**GUARDED ENCLOSURE** This provision limits the size of the ventilating opening to prevent accidental contact with the operating parts of the motor other than the shaft.

**SEMI-GUARDED** This is an open construction where some of the ventilating openings are guarded and the remaining openings are left open.

**OPEN, EXTERNALLY VENTILATED** This motor is ventilated by a separate motor-driven blower mounted on the motor enclosure (piggyback construction).



**OPEN, PIPE-VENTILATED** This motor is equipped to accommodate an air-inlet duct or pipe for accepting cooling air from a location remote from the motor. Air is circulated in the motor either by its own internal blower parts or by an external blower, in which case the motor is said to be *forced-ventilated*.

**WEATHER-PROTECTED TYPE I** This is an open-construction motor with ventilating openings to minimize the entrance of rain, snow, and airborne particles to the motor's electrical parts, and with the openings arranged to prevent the passage of a  $\frac{3}{4}$ -in (19-mm) round rod.

**WEATHER-PROTECTED TYPE II** This construction has the same features as the type I machine, but in addition the intake and discharge ventilating passages are designed so high-velocity air and airborne particles blown into the machine by storms can be discharged without entering the internal ventilating passages of the motor leading to the electrical parts. The ventilating passages leading to the electrical parts of the motor are provided with baffles or other features to allow at least three abrupt changes of at least 90° for the ventilating air. The intake air path and openings are proportioned to maintain a maximum of 600 ft/mm (3 m/s) velocity of the entering air.

**TOTALLY ENCLOSED** This motor is designed without air openings, so there is no free exchange of air between the inside and outside of the motor frame; the construction is not liquid- or airtight. Normally the rotor has die-cast air circulating fins at each end to circulate the trapped inside air and improve convection cooling to the frame.

**TOTALLY ENCLOSED, FAN-COOLED** This totally enclosed motor is equipped with an external fan operating on the motor shaft to circulate external air over the outside of the motor. Most motors have cast fins the length of the frame to increase surface area and take advantage of the fan cooling.

**EXPLOSIONPROOF** This totally enclosed motor is designed to withstand an internal explosion of gas or vapor and constructed to prevent ignition by the internal explosion of gases or vapors outside the motor.

**TOTALLY ENCLOSED, PIPE-VENTILATED** This motor enclosure is similar to the open, pipe-ventilated motor except that it is equipped to accept outlet ducts or pipes in addition to inlet ducts or pipes.

**TOTALLY ENCLOSED, WATER-COOLED** This is a totally enclosed motor cooled by water passages or conductors internal to the motor frame.

**TOTALLY ENCLOSED, WATER-TO-AIR HEAT EXCHANGE** This is a totally enclosed motor equipped with a water-to-air heat exchanger in a closed, recirculating air loop through the motor. Air is circulated through the heat exchanger and motor by integral fans or fans separate from the rotor shaft and powered by a separate motor.

**TOTALLY ENCLOSED, AIR-TO-AIR HEAT EXCHANGE** This motor is similar to the water-to-air heat exchanger motor, except external air is used to remove the heat from the heat exchanger instead of water.

**SUBMERSIBLE** This totally enclosed motor is equipped with sealing features to permit operation while submerged in a specified medium at a specified depth.

**Environmental Factors** The environmental conditions of the pump application dictate the type of motor enclosures to be used. A brief set of rules for selecting motor enclosures follows.

**DRIPPROOF** For installation in nonhazardous, reasonably clean surroundings free of any abrasive or conducting dust and chemical fumes. Moderate amounts of moisture or dust and falling particles or liquids can be tolerated.

**MILL AND CHEMICAL MOTOR (TO NEMA FRAME 449T)** For installation in nonhazardous, high-humidity, or chemical applications free of clogging materials, metal dust, or chips, or where hosing down or severe splashing is encountered.

**TOTALLY ENCLOSED, NONVENTILATED OR FAN-COOLED** For installation in nonhazardous atmospheres containing abrasive or conducting dusts, high concentrations of chemical or oil vapors, where hosing down or severe splashing is encountered.

**TOTALLY ENCLOSED, EXPLOSIONPROOF** For installation in hazardous atmospheres containing:

- Class I, Group D* Acetone, acrylonitrile, alcohol, ammonia, benzene, benzol, butane, dichloride, ethylene, gasoline, hexane, lacquer-solvent vapors, naphtha, natural gas, propane, propylene, styrene, vinyl acetate, vinyl chloride, or xylenes
- Class II Group G* Flour, starch, or grain dust
- Class II, Group E* Metal dust including magnesium and aluminum or their commercial alloys.
- Class II, Group F* Carbon black, coal, or coke dust

**NOTE:** Under Class 1 only, there are two divisions that allow some latitude on motor selection. Generally, Class 1, Division 1 locations are those in which the atmosphere is or may be hazardous under normal operating conditions, including locations which can become hazardous during normal maintenance. An explosionproof motor is mandatory for Division 1 locations. Class 1, Division 2 refers to locations where the atmosphere may become hazardous only under abnormal or unusual conditions (breaking of a pipe, for example). In general, a motor in a standard enclosure can be installed in Division 2 locations if the motor has no normally sparking parts. Thus, open or standard totally enclosed squirrel-cage motors are acceptable, but motors with open slip rings or commutators (wound rotor, synchronous or dc) are not allowed unless the commutators or slip rings are in an explosionproof enclosure.

## **BEARINGS AND LUBRICATION**

---

Very large horsepower (kilowatt) motors are generally supplied with oil-lubricated sleeve bearings with oil supplied from a reservoir. In some cases, pressurized oil lubrication systems are installed by the pump manufacturer along with hydrodynamic thrust bearings. All NEMA frame induction motors are available with ball bearings. These standard ball bearings are normally permanently grease lubricated. The bearings used in a motor must be sealed to keep the lubricant inside the bearings and keep contaminants from getting into the bearings. Double-sealed bearings are common for many pump applications.

Ball bearings are subject to early failure when used in electric motors driven by PWM inverters. This very common problem must be addressed. It is caused by the high carrier frequency used in the inverter to generate the sinusoidal currents for each phase. This results in generation of high common-mode voltages inside the phase windings of the stator. Because there is an excellent electrostatic coupling between the stator/frame and the rotor from the windings, a voltage is induced in the shaft. The ball bearings represent the least-resistant path for a short circuit to the stator. However, the balls seldom actually contact the races because of the film of grease or oil in between. When the voltage builds up in the shaft until it is greater than the insulating capability of the film of lubricant, the voltages arc across the lubrication gap and a flashover current goes through the bearing. In a relatively short amount of time, the bearing races will become grooved, causing the bearings to become noisy. Metal particulate will then egress from the bearing surfaces as the process continues, causing catastrophic bearing failures after a few months.

Therefore, all electric motors that are driven by PWM drives must have a shaft grounding system to provide a low resistance path between the shaft and the motor

frame. There are other solutions to this potential problem, which can be discussed with the motor supplier.

**Sleeve Bearings** Motors that use oil-impregnated porous sleeve bearings are lubricated with an oil-soaked wick. These bearings are available in motors up to approximately 1 hp (0.75 kW). Sleeve-bearing motors larger than 1 hp (0.75 kW) are ring-lubricated. Lubricating oil is drawn up from the bearing sump to the bearing by a ring that rolls over the top of the motor shaft as the shaft rotates. Larger motors, having bearing heat losses that cannot be dissipated directly, may require the use of a pressurized lubrication system wherein oil is pumped into the bearings and allowed to recirculate through a heat exchanger. The oil delivered to each bearing is metered to provide only the required amount. A lubrication system composed of heat exchanger, sump, and pump is normally common to a number of bearings, rather than having a single lubricating pump for each bearing. Other types of bearings must be used in place of, or in addition to, sleeve bearings when thrust loads are present. Smaller sleeve bearings are in the form of a cylindrical shell and are usually made of bronze or steel-backed babbitt metal. Larger sleeve bearings are usually split on a horizontal centerline, allowing easy assembly and disassembly for inspection and replacement. The bearing housing is also split on the horizontal centerline and held together with bolts between the top and bottom halves.

**Rolling Element Bearings** All new electric motors manufactured to NEMA standards use grease-lubricated ball bearings with high radial and thrust load capacities. They are axially pre-loaded to eliminate any radial or axial play for quiet operation and long life. Most motor end frames include an outer race locking plate on the shaft end bearing to prevent race rotation due to output shaft loads. These bearing mounting features are required for high performance, long life, and high efficiency operation. Most motor manufacturers provide their larger frame sizes with grease fittings for relubrication during the lifetime of the motor. The smaller frames use bearings that are grease-packed and sealed for life at the factory and cannot be relubricated.

NEMA motors subject to very high loads and operating temperature in the larger frames may require oil lubrication to the rolling element bearings. This can be by either oil circulation within the bearing frame or from a pressurized lubrication system similar to that used with sleeve bearings. In addition, for motors required to carry very high thrust loads, quite often in only one direction, taper or spherical roller thrust bearings may be used.

**Hydrodynamic Thrust Bearings** Certain types of pump applications, such as very large vertical pumps, exhibit very high thrust loads that cannot be accommodated by rolling element bearings. Hydrodynamic bearings, usually with tilting, self-leveling thrust pads, are used for very high thrust loads. These bearings are sometimes referred to as "Kingsbury-type" in recognition of the original manufacturer of this bearing type. This type of bearing is oil-lubricated from a self-contained oil sump or an external pressurized pumping system, depending on size and rating.

## **MOTOR INSULATION**

---

Insulation systems must be used in a motor to electrically insulate the windings from the mechanical parts of the motor as well as to insulate the phase winding conductors from one another. Extra insulation is also required between any adjacent phase windings for 230 or higher voltage motors. In general, the higher the operating voltage, the better the insulation system must be.

All NEMA-designed electric motors are manufactured with cord laced end turns to assure that they are positioned so they cannot touch any mechanical parts. In addition, the phase windings are nearly always impregnated with a varnish by either dipping or trickling into the heated end turns. The purpose of this is to secure the conductors to prevent them from vibrating between one another, which would wear through the wire insulation

and cause turn-to-turn shorts. This stator varnish also provides some additional insulation protection to the system. For example, this coating makes the windings resistant to ambient conditions such as moisture. Consequently, a motor insulation system is very complex, utilizing several different materials, parts, and processes to effectively insulate the windings. The parts considered in an insulation system include slot cells, phase barriers, conductor insulation, slot wedges, end turn supports, tie material, and winding impregnation material.

Since the introduction of PWM inverters for use with all types of variable speed drives, such as ac induction, PM brushless and switched reluctance brushless, a new insulation system failure mode has emerged. This is a most significant problem in installations where the inverter is located 50 ft (15 m) or more away from the motor. The long motor lead cables used in these applications cause very high voltage spikes not present at the inverter end of the lead cables. These voltage spikes across the first turns of each phase winding result in the degradation of the wire insulation due to the corona insulation failure. Special magnet wire insulation and motor manufacturing methods are available to overcome this problem. Therefore, if an inverter is to be used to drive a pump motor with long connection cables, an “inverter duty” motor should be specified.

There are four basic classes of insulating materials currently recognized by the motor industry. Each differs according to its physical properties and can withstand a certain maximum operating temperature (frequently termed total *temperature* or *hot-spot temperature*) and provide a practical and useful insulation life. The insulation classes and their maximum operating temperatures are

Class A	90°C
Class B	130°C
Class F	155°C
Class H	180°C

Those factors that contribute to the maximum operating temperature of a motor insulation system are the ambient temperature, the temperature rise in the motor winding caused by motor losses, and any overload allowance designed into the motor (service factor).

The current standard for motors within the range of NEMA ratings (frames 140T to 449T) requires nameplate marking for the maximum allowance ambient temperature, the power rating, the associated line current needed to develop this power, the class of insulation used, and the service factor provided. Motors larger and smaller than NEMA frame sizes have nameplate marking for maximum allowable ambient temperature, temperature rise in degrees Celsius either by thermometer or resistance measurement, power rating, line current needed to develop this rating, and any service factor provided.

In addition to ambient temperature, there are several additional environmental conditions that must be considered when applying an electric motor. In applications where chemical fume or moisture levels are abnormal and can cause decomposition of an insulation system, standard insulation will be inadequate. These applications require a motor with a premium insulation system that will incorporate highly resistant components and may include special impregnation techniques. Chemical fumes and moisture can also be destructive to the mechanical parts of a motor, and special protective treatment should be provided to these parts. NEMA frame-size motors have a special motor for chemical industry applications that has standard features to resist these environmental factors. For example, these motors usually contain shafts made from stainless steel.

Applications with excessive vibration can destroy a winding and damage the mechanical parts of a motor. In such cases, it is advisable to provide (1) extra treatment for the winding to ensure that it is rigid and will not vibrate and chafe the insulating materials and (2) a mechanical construction that will have the strength to withstand the above.

If abrasive dust is present, the motor insulation should be protected with a resilient surface coating to withstand the impact of the abrasive particles.

Because all insulation systems employ components that can in some degree support fungus growth in tropical locations, motors applied in such areas should incorporate fungus-proofing treatment on the insulation.

Obviously, applications exhibiting a combination of any or all of the environmental conditions discussed should have special protection for each condition. Applications in unusual environmental conditions may require special protection and should be discussed with the motor manufacturer or distributor.

## COUPLING METHODS FOR PUMP APPLICATIONS

---

**Direct Coupling** Pumps are frequently directly coupled to motors, and where the pump is not close-coupled, it is usually coupled by means of a flexible coupling. The use of a flexible coupling permits minor misalignment (angular and parallel) between motor and pump shafts. The use of some older style flexible or solid couplings could cause severe radial and axial loads on the motor bearings. Since the development of the flexible disk couplings, the earlier coupling designs have largely disappeared, as have the severe loads resulting from misalignment. The flexible disk coupling is capable of transmitting very high torque for its size, with minimum radial and axial forces on the shafts resulting from misalignment. [See Subsection 6.3.1.]

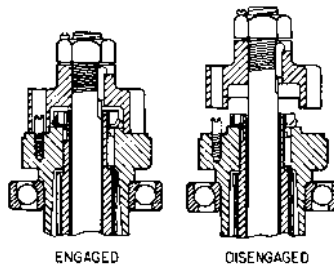
**Close-Coupling** Close-coupled pumps have become very popular for certain applications. In this arrangement, no coupling is provided between the pump and motor shafts and the pump housing is flange-mounted between close-tolerance fits on both the motor and the pump flanges. The pump impeller is mounted directly on the motor shaft. Care must be taken in this arrangement to ensure that the motor shaft runout or axial movement plus machine tolerances do not cause interference between the pump housing and its rotor. This is usually not a problem if properly fitted ball bearings are used in the motor. The motor shaft material must be compatible with the fluid being pumped, and if the pump impeller is held in place by a nut, the threat must respect the rotation of the motor. High-pressure close-coupled pumps of a nonbalanced design can cause excessive shaft thrust, which may be incorporated in the motor bearing capacity. It is always good practice with close-coupled pumps to provide some form of flinger on the motor shaft to prevent liquids that leak past the pump seal from entering the motor bearing.

**Flanged Motors** Flanged motors allow an easy means of aligning pump housings with motors. This construction is usually in the form of a vertical mounting in which the motor is set on top of the pump and the pump supports the motor weight. The pump and motor shafts are normally coupled, and those comments made under the subject of direct-coupling methods are applicable. Also, as in the case of coupled pumps, this construction permits thrust forces that must be considered when selecting a motor if the pump does not have a thrust bearing.

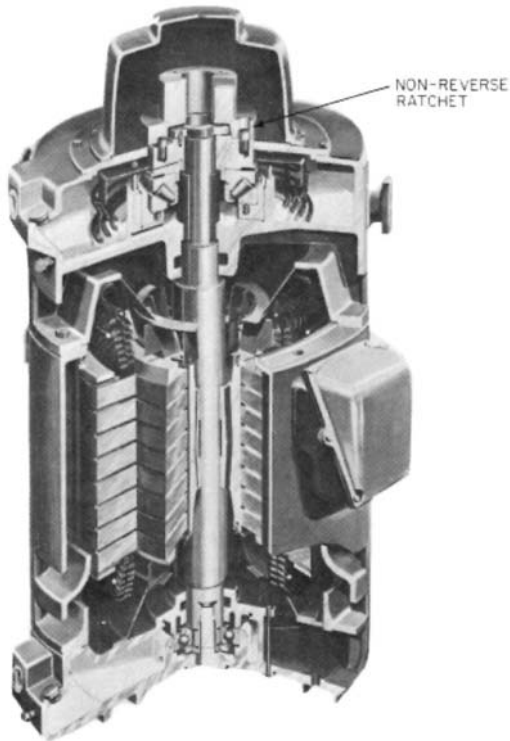
A further extension of flange motors includes the vertical hollow-shaft motor. With this design, a variable length of shafting connects the pump and motor. The pump shaft passes through the center of the motor bore, and the motor torque is imparted to the pump shaft by a suitable coupling at the top of the motor. The weight of the shaft and the pump impeller and the force of the hydraulic thrust are assumed by the motor bearings.

The coupling on the motor can be made a *self-release coupling* (Figure 17) to prevent the motor from delivering torque to the shaft in the event the motor is started in the wrong direction and to prevent reversed motor rotation from unscrewing the threaded joints between lengths of pump shafting.

Another modification to a coupling is a nonreverse *ratchet* (Figure 18), which prevents the remaining head of liquid in a pump from rotating the pump in the reverse direction when the pump is stopped. This prevents possible overspeeding of the pump and motor when the pump is connected to a large reservoir and most of the total pump head is static. This also prevents a pump with a long discharge column pipe from running in reverse with no liquid in the upper portion of the pipe to lubricate the line shaft bearings. Starting a pump capable of back spinning is also prevented.



**FIGURE 17** Self-release coupling connecting pump head shaft to hollow shaft of vertical motor disengages as a result of pump shaft couplings unscrewing (U.S. Electrical Motors).



**FIGURE 18** Section of vertical hollow shaft motor showing nonreverse ratchet. Spring-loaded pins ride on ratchet plate in one direction only (General Electric).

## PERFORMANCE

---

Ac induction motors are designed to produce their rated power at a certain speed at a specific line voltage, line frequency, and ambient temperature. These motors will also operate at a specific efficiency and power factor when all of these conditions are met. The normal operating conditions of a motor are stipulated on its nameplate with values for power,

speed, ambient temperature, and frequency. If the operating conditions are different from the nameplate ratings, the motor performance will be altered. Many of the newer PM and SR brushless motors are designed to produce their rated output power over a wide speed range. A high efficiency ac induction motor can also perform similarly if a Flux Vector Inverter is used for control.

**Voltage** Ac motors are designed to operate satisfactorily at their nameplate voltage rating with a  $\pm 10\%$  variation from nameplate voltage when operating at rated nameplate frequency. This dictates that the motor will develop rated power and speed to a pump and will operate at a safe insulation temperature over the range of voltage. The motor torque will vary directly with the square of the applied voltage divided by the nameplate voltage. This affects the peak torque of the motor and will cause the motor speed-torque curve as shown in Figure 2 to be altered. Within the  $\pm 10\%$  voltage band, a motor can be expected to accelerate and operate a pump safely and continuously. A motor should never be expected to operate continuously beyond the  $\pm 10\%$  band. If the voltage varies more than  $\pm 10\%$ , the pump and motor may not operate satisfactorily.

For example, assume a pump is operated by a NEMA design B motor (refer to Figure 2) that will produce 200% pull-out torque at rated voltage. If the line voltage were to fall to 70% of the rated name-plate voltage, the motor would produce only 49% of its peak torque value. The pull-out torque of the motor would then become  $0.49 \times 200 = 98\%$  of rated torque. It then becomes very doubtful whether the motor will be able to sustain the pump load, and the motor can be expected to lose speed, stall, or become overloaded. Certainly, it will also heat up, which will shorten the expected life of the bearing lubrication and winding insulation system.

In a similar sense, a motor may be unable to accelerate a pump if low line voltage exists. In the example previously discussed, this same motor develops 150% of rated torque when started at zero speed and rated voltage. If the line voltage is again 70% of nameplate voltage, the motor will develop  $0.49 \times 150 = 73\%$  of rated torque. This may be a problem with certain types of pumps, such as a constant displacement pump. It is conceivable that this would not be a problem in starting a centrifugal pump because of its square-law speed-torque characteristics. If the motor voltage never increased beyond 70%, the centrifugal pump would not reach normal operating speed. An exception to this rule is the commutating ac motor, for which a  $\pm 6\%$  voltage variation is allowable.

Varying motor voltage from nameplate rated voltage will also affect the motor operating speed, power factor, and efficiency established for rated voltage and load. Most polyphase ac induction motors will operate at several rpm faster than nameplate speed at 10% over voltage and several rpm below nameplate speed at 10% under voltage. The speed of a synchronous motor is determined by the line frequency of the alternating voltage not the voltage level. Therefore, voltage variation has no effect on the speed of a synchronous motor. However, voltage variation does effect maximum torque output of a synchronous motor.

Dc motors can also be operated over a  $\pm 10\%$  voltage range from nameplate rated voltage. However, it should be recognized that different types of dc motors will have different speed and torque characteristics over the voltage range. This should be taken into account when meeting pump performance requirements.

One of the most common applications for dc motors has been for metering pumps because of their ease of setting the speed to precisely meter the fluid being pumped. Although a voltage variation would change the pump speed, it is customary to include a speed control loop with the dc supply to maintain constant speed in spite of line voltage variations.

**Frequency** Ac induction motors will operate satisfactorily at rated load and voltage with a frequency variation up to  $\pm 5\%$  from rated nameplate frequency. However, the speed of the motor will vary almost directly with the line frequency. The speed of a synchronous motor will vary directly with applied frequency. The combined variation of voltage and frequency must not be more than  $\pm 10\%$  from rated nameplate voltage and frequency, provided the frequency variation does not exceed  $\pm 5\%$  from rated nameplate frequency. The reason is that frequency variation from the nameplate frequency will cause motors to



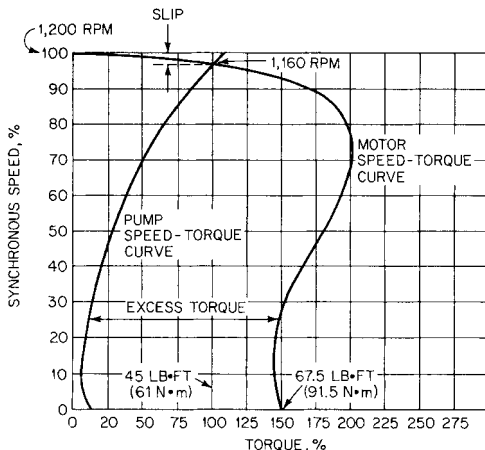
operate at a power factor and efficiency other than those established for rated frequency. Any electric motor such as PM or SR brushless and even ac induction, which is powered from an inverter, is unaffected by frequency variations.

**Speed and Speed Range** Synchronous and induction motors were originally expected to be operated at one specific speed when powered from line voltage and frequency. However, with the availability of inverters, this is no longer the case. In fact, the use of inverters for driving induction motors is expanding at a fast pace as the merits and benefits of adjustable speed are being realized. The use of speed controlled PM and SR brushless motors along with their inverters and controllers allow the pump application to take advantage of the usefulness of adjustable speed. Using the inverter with any of these types of motors eliminates any difficulties from speed variations from the past. This is because most inverters have a speed control loop that will automatically maintain the set speed.

**Acceleration** A motor must be capable of accelerating as well as driving a pump at rated speed and power. The acceleration can be analyzed by examining a typical pump-motor combination involving a centrifugal pump driven by a six-pole squirrel-cage induction motor rated 10 hp (7.46 kW) with NEMA design B torque characteristics. The curve in Figure 19 demonstrates this combination when the pump is loaded and the motor is operating at nameplate frequency and voltage. It will be noted that the torque produced by the motor at any speed must be greater than the torque required by the pump when up to speed. The excess torque at any speed is available to accelerate the motor, coupling, and pump rotating parts.

NEMA has provided a handbook for motion control that outlines the fundamental equations for the required torque calculations to accelerate any inertial loads to a predetermined speed. For the use of ac induction motors that are line-fed with constant voltage and frequency, the formulas are used to calculate the time to the motor slip from synchronous speed for a given total rotating inertia. For the use of inverter-fed ac induction, PM or SR brushless motors, the formulas are used to determine the torque required to accelerate the total rotating inertial load to the desired speed in the desired time.

The fundamental equations for motion, which include torque, inertia, time and acceleration relationships, are given below. They can be used for motor selection analysis for pumps. For example, if the torque available from an induction motor is known, the equation can be solved for the acceleration time of the system inertia (from NEMA "Programmable Motion Control Handbook").



**FIGURE 19** Typical speed-torque characteristic curves for a centrifugal pump and a squirrel-cage induction, NEMA design B motor. Excess torque accelerates pump.



$T_{TOTAL} = T_A + T_C$ : Total torque = Acceleration torque + constant torque

$T_A = J_{TOTAL} \times \alpha$ : Acceleration torque = Inertia  $\times$  Angular acceleration

$\alpha = \frac{\omega_{max}}{t_a} \times 2\pi$ : Angular acceleration = Max RPM/acceleration time

$T_C$  = Torque from all other constant forces, friction, windage, preload, and so on.

NOTE: Use consistent units depending on whether U.S. Customary or SI. The time to accelerate the pump is equal to

$$\text{in USCS units} \quad t = \frac{WK^2 \times \Delta\text{rpm}}{308T}$$

$$\text{in SI units} \quad t = \frac{MK^2 \times \Delta\text{rpm}}{9.55T}$$

where  $t$  = time, s

$WK^2$  = total weight (force) moment of inertia, lb  $\cdot$  ft<sup>2</sup>

$\Delta\text{rpm}$  = change in speed

$T$  = torque, lb  $\cdot$  ft ( $N \cdot m$ )

$MK^2$  = total mass moment of inertia, kg  $\cdot$  m

Because the difference in torque is not uniform over the speed range, the curve (Figure 19) can be analyzed by assuming discrete changes in speed and an average torque over this change in speed. A time period can be calculated for each discrete speed change, and all time values can be totaled to obtain the complete acceleration time.

Increasing the inertia of the pump, the operating speed of the pump and motor, or the torque required by the pump at any speed will result in a longer acceleration time, which may not be possible for the motor. Each motor can operate at a reduced speed and at a torque in excess of rated torque for a given time. Beyond this time, the windings and/or rotor can be damaged. The use of an inverter-driven ac induction SR or PM brushless motor eliminates all of these problems associated with the use of line-fed ac induction motors. This is due to the torque control capability of the inverter/motor drive system using current control. The limit on the ability of the adjustable speed drive to control acceleration is a function of the current capability of the inverter (as long as the thermal limit of the motor has not been exceeded).

When an application is analyzed and found to present an acceleration-time problem, consideration should be given to

1. Unloading the pump during acceleration
2. Reducing the inertia of the rotating parts
3. Selecting a larger motor
4. Considering an adjustable speed motor and drive

When very large pumps are started, the line voltage will sometimes drop because of the high starting current, which causes the motor torque to be reduced by the square of the voltage ratio. Naturally, the acceleration time is greater because of the reduced torque produced by the motor. This will not hamper the ability of the motor to accelerate the pump as long as the motor develops more torque than is required to drive the pump at any speed over the accelerating range. The use of SR or PM brushless induction motors eliminates this problem because these motors do not draw high inrush currents. In fact, the starting current is controlled very precisely.

A similar analysis can be made for synchronous motors after the accelerating speed-torque curve for the motor is known. It should be recognized that a synchronous motor operates as a squirrel-cage induction motor up to the moment of synchronization. At that time, the synchronous motor must have an additional capability of synchronizing torque,

frequently called *pull-in torque*, to accelerate the motor from subsynchronous to synchronous speed. If the motor cannot develop enough torque at its synchronous speed, it will pull out or stall. When this type of motor is used for a pump, it is advisable to unload the pump during acceleration operation to reduce the torque required from the motor for acceleration.

When using a synchronous motor, attention should always be given to the breakaway torque that is required to start the pump from zero speed. This is particularly important with constant displacement pumps, where the pump will operate at a constant torque over the entire accelerating speed range. Again, a better selection might be an inverter-driven ac induction motor, SR or a PM brushless motor.

**Service Factor** Motors are available with service factor ratings that range from 1.0 to as high as 1.5. A service factor implies that a motor has a built-in thermal capacity to operate at the nameplate power times the service factor stamped on the nameplate. It should be noted, however, that when the motor is operated at the service factor power, the motor will operate at what is termed a *safe temperature*. This means that the motor will operate at a total temperature that is greater than the temperature for a motor designed for the same power with a 1.0 service factor. Consequently, it is not advisable to apply a motor with a service factor larger than 1.0 where the continuous power requirements will be greater than the normal power.

A service factor rating on a motor is to provide an increased power capacity beyond nominal nameplate capacity for occasional overload conditions. Also, the speed-torque characteristics are related to the nominal power rating and not the service factor power. When adjustable speed motor/drive systems are selected, the old service factor ratings are not useful. The supplier of the drive system will assist in selecting a thermally rated system that will satisfy the pumping operation. All inverters are equipped with thermal safety protection for both the motor and the drive so the system cannot be overloaded to minimize overheating. This is a very useful feature for many pump applications.

**Efficiency** Motors are designed to operate with an efficiency expressed in percent at rated voltage, frequency, and power. Efficiency is defined as

$$\text{Efficiency \%} = \frac{\text{shaft output power} \times 100}{\text{electrical input power}}$$

The efficiency of a given motor design will vary slightly from unit to unit because of manufacturing tolerances and variations in materials. For this reason, guaranteed efficiencies are usually lower than actual efficiencies. When motors are operated at reduced powers, the tendency is for the efficiency to decrease because the losses tend to be fixed.

Several other factors have an effect on motor efficiency. Increasing the applied voltage and operating a motor at its rated power will increase efficiency very slightly, whereas decreasing applied voltage will decrease the efficiency noticeably. Also, increasing the frequency will cause a very slight increase in efficiency, and decreasing the applied frequency will cause a slight decrease in efficiency.

Inverter-fed ac induction and PM or SR brushless motors are not subject to changes in their efficiencies due to changes in line voltage or frequency because the ac line voltage is rectified into a dc voltage before the regeneration of the power to the motor. The dc voltage is always reasonably constant and unaffected by changes in the line power. This of course assumes that there is sufficient voltage and power headroom in the design.

Dynamometers are used to determine efficiency for small motor ratings—up to approximately 500 hp (373 kW)—and standard methods and formulas are used for calculating efficiency for large motors. For the latter, efficiency values can vary, depending upon which “standard” procedure is used. Several suppliers market torque and power analyzers for induction motors that base their output on these formulas using current data measured from the motor. These methods are accurate enough to be acceptable. They have been reasonably verified by applying the method to smaller motors that have been tested on a

dynamometer. NEMA has established one method, but some suppliers use different methods, depending upon their national standards or established practices.

Higher efficiencies have been designed into most new motors by selecting materials and proportions that reduce losses, but such design choices usually make the motor more costly. This also includes filling the stator slots with more copper of a larger wire gage to reduce ohmic losses. These new motors designed for higher efficiencies offer improvements from 2% to as high as 7% depending upon the size and manufacturer.

Motor operating efficiency in a typical application often may not be that described by the manufacturer. Quoted efficiencies are always at rated power output, rated frequency, and rated voltage. However, it is almost universal in application that a motor is oversized for its applied load and frequently operates at other-than-normal voltage. Both of these variables can greatly reduce the efficiency of a motor. However, when a motor is inverter-driven, the efficiency of the system can be much better controlled.

**Power Factor** The power factor of a motor is expressed as

$$PF = 100 \cos \theta$$

where  $\theta$  is the angle between voltage and current at motor terminals (leading or lagging).

The power factor at which a motor operates is dependent on the design of the motor and is established at rated voltage, frequency, and power output.

For induction motors, the power factor can never be 100% leading. A number of factors will influence the power factor of an induction motor:

Condition	Effect on power factor
Increase applied voltage	Decrease
Decrease applied voltage	Increase
Increase load	Increase
Decrease load	Decrease
Increase applied frequency	Slight increase
Decrease applied frequency	Slight increase

In synchronous motors, it is usual to use two varieties of motors, the 100 (unity) and 80% leading motors. The power factor of a synchronous motor operated at rated voltage and frequency is fixed by its field excitation and its power output. At a given power output, the power factor can be adjusted over a range by adjusting the field excitation. Increasing the field excitation will cause the motor to operate at a more leading power factor, and, conversely, reducing the field excitation will make the power factor lag.

Varying the power output of a synchronous motor with a constant field excitation will vary the operating power factor. A decrease in power output will cause a more leading power factor; conversely, increasing the power output will induce operation at a lagging power factor. Consequently, to operate the motor at rated power factor with a varying output power, it is necessary to adjust the field excitation. However, this is not normally done because a synchronous motor is frequently used for improving the power factor and the more leading power factor is used to accommodate power factor improvement. When a synchronous motor is overloaded and operates at a more lagging power factor, it is not usual to increase the excitation beyond its rated excitation because of the extra heating this will develop in the motor. In this case, the more lagging power factor is simply accepted.

The power factor is not of much concern for SR and PM brushless motors driven by inverters because of the control capabilities for these systems. The PM machine exhibits the best power factor of any known motor under nearly all operating speeds and power levels except if excessive field weakening or phase advance is used.

## TYPES OF CONTROLS

---

In order to use an electric motor to drive a pump, a means of starting and stopping the motor is required. The devices used for this purpose can be called controls. Only small—perhaps up to two or three hp (kW)—motors can be controlled with a simple on-off switch (starting from full rated line voltage). This is because when a motor is first started it produces no back EMF and will draw very high starting currents. If the load inertia is very high, the motor can overheat during the long acceleration time. In addition, the high starting current peaks can cause heavy dips in the line voltage. Therefore, for larger motors, these line voltage dips must be minimized by the use of starters. There are four basic ways to start ac induction motors:

1. Direct online starting
2. Low voltage starting
3. Rotor resistance starting
4. Low frequency starting

Other devices used to control motors such as *soft starters*, *adjustable frequency controls*, and *vector drives* are discussed along with the inverters and controls for other motor types such as dc motors, SR and PM brushless in Subsection 6.2.2.

### Alternating-Current Motor Starters

**MANUAL STARTERS** Manual motor starters are designed to provide positive overload protection and start and stop control of single-phase and polyphase motors up to about 3 HP (2.5 kW). A single manual toggle switch or a push button switch is used for “on,” “off,” and “tripped” states. These types of starters use full line voltage applied to the motor.

**MAGNETIC STARTERS** Magnetic motor starters cost more and are more reliable than manual starters. They are designed to control a motor by incorporating a magnetically operated contactor to apply power to the motor terminals rather than allowing full current to pass through the contacts.

An overload relay is incorporated to protect the motor from overloading. Magnetic starters are available for reversing and nonreversing service and are also made as non-combination or combination types. The non-combination starter combines only the motor contactor and overload relay. The combination starter combines these parts along with either a circuit breaker or a fused switch to provide shortcircuit protection.

**REDUCED-VOLTAGE STARTERS** Reduced-voltage starters are available in several types and are basically magnetic starters with additional features to provide reduced voltage, which in turn provides for reduced motor-starting current or torque. These starters include the types discussed in the following paragraphs.

**Primary-Resistor Starters** Primary-resistor starters, sometimes known as *cushion-type* starters, will reduce the motor torque and starting inrush current to produce a smooth, cushioned acceleration with closed transition. Although not as efficient as other methods of reduced-voltage starting, primary-resistor starters are ideally suited to applications where reduction of starting torque is of prime consideration. A typical diagram for this type of starter is shown in Figure 20.

**Autotransformer Starters** Autotransformer starters are widely used reduced-voltage starters because of their efficiency and flexibility. All power taken from the line, except

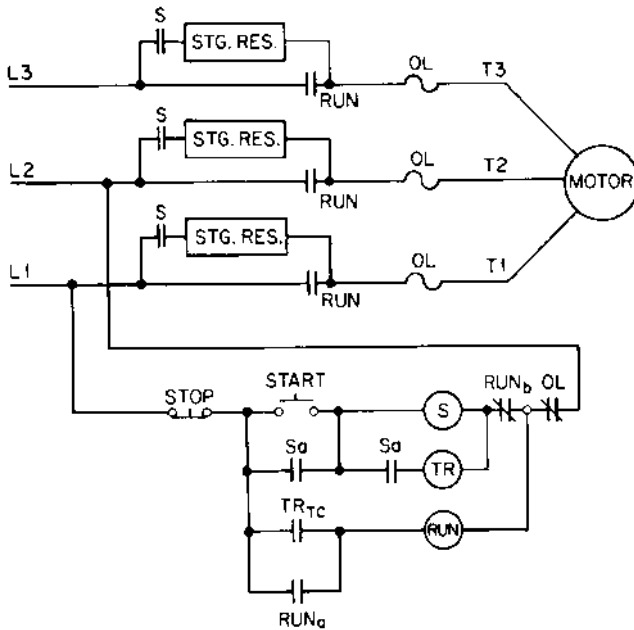


FIGURE 20 Typical primary-resistor, reduced-voltage starter wiring diagram (Westinghouse Electric)

transformer losses, is transmitted to the motor to accelerate the load. Taps on the transformer allow adjustment of the starting torque and inrush to meet the requirements of most applications. The following characteristics are produced by the three voltage taps:

Tap, %	Starting torque, % locked torque	Line inrush, % locked current
50	25	28
65	42	45
80	64	67

A typical diagram for this type of starter is shown in Figure 21.

*Part-winding starting* provides convenient, economical, one-step acceleration at reduced current where the power company specifies a maximum or limits the increments of current drawn from the line. These starters can be used with standard dual-voltage motors on the lower voltage and with special part-winding motors designed for any voltage. When used with standard dual-voltage motors, it should be established that the torque produced by the first half-winding will accelerate the load sufficiently so as not to produce a second undesirable inrush when the second half-winding is connected to the line. Most motors will produce a starting torque equal to between one-half and two-thirds of NEMA standard values with half the winding energized and draw about two-thirds of normal line-current inrush. A typical diagram is shown in Figure 22.

*Star-delta starters* have been applied extensively to starting motors driving high-inertia loads with resulting long acceleration times. They are not, however, limited to this application. When 6 or 12 lead delta-connected motors are started star-connected, approximately 58% of full-line voltage is applied to each winding and the motor develops 33% of full-voltage starting torque and draws 33% of normal locked rotor current from the line.

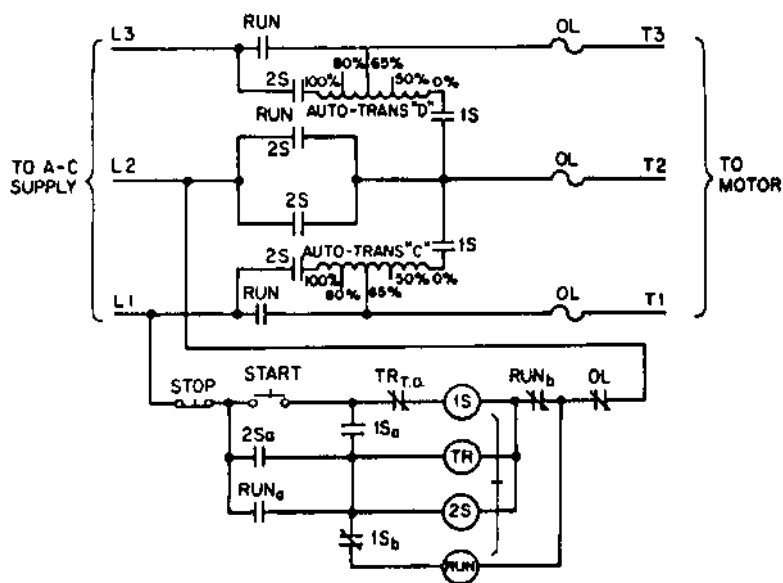


FIGURE 21 Typical autotransformer, reduced voltage starter wiring diagram (Westinghouse Electric)

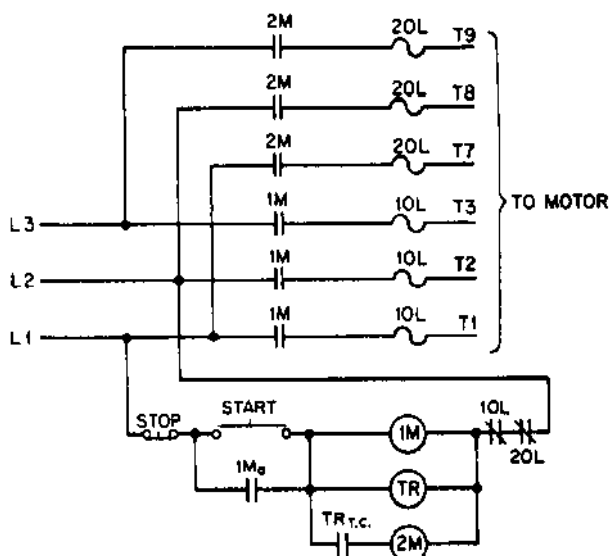


FIGURE 22 Typical part-winding starter wiring diagram (Westinghouse Electric)

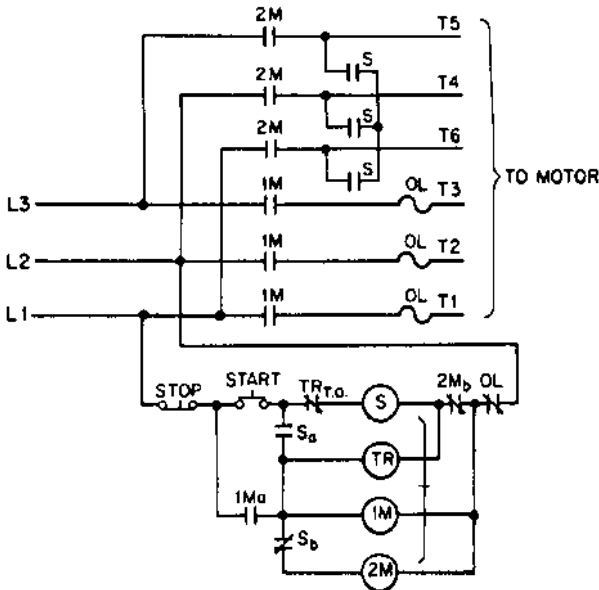


FIGURE 23 Typical star-delta, reduced-voltage starter wiring diagram (Westinghouse Electric)

When the motor has accelerated, it is reconnected for normal delta operation. A typical diagram is shown in Figure 23.

**Wound Rotor Motor Starters** These magnetic motor starters are used for starting, accelerating, and controlling the speed of wound-rotor motors. The primary control includes overload protection and low-voltage protection or low-voltage release, depending on the type of pilot device. Disconnect switches, circuit breakers, and reversing can be added to the primary circuit when required. Reversing starters are not designed for plugging.

The secondary circuit contains the NEMA recommended number of accelerating or running contactors and resistors to allow approximately 150% of motor full-load torque on first point of acceleration. Additional accelerating points can be added for high-inertia loads or exceptionally smooth starts. Adjustable timing relays permit field adjustment. Standard starting duty NEMA 135 resistors allow 10 s starting out of every 80 s. A typical diagram is shown in Figure 24.

**Synchronous-Motor Starter** Synchronous, magnetic, full-voltage starters provide reliable automatic starting of synchronous motors. They can be used whenever full-voltage starting is permissible. Automatic synchronization is provided by field relay, which assures application of the field at the proper motor speed and at a favorable angular position of stator and rotor poles. As a result, line disturbance resulting from synchronization is reduced and effective motor pull-in torque is increased. A typical diagram is shown in Figure 25.

Brushless synchronous-motor starters require special consideration inasmuch as all brushless synchronous motors are not constructed in the same way. The usual starter incorporates a low-power adjustable dc excitation source to energize and control the output of an integral shaft-connected exciter.

In addition, a pull-out relay and a timing relay are incorporated to initiate synchronization and stop the motor in event of pull-out.

**Direct-Current Motor Starters** Direct-current motor starters are designed to apply normal voltage to the motor field and, by means of a resistor, reduce voltage to the armature.

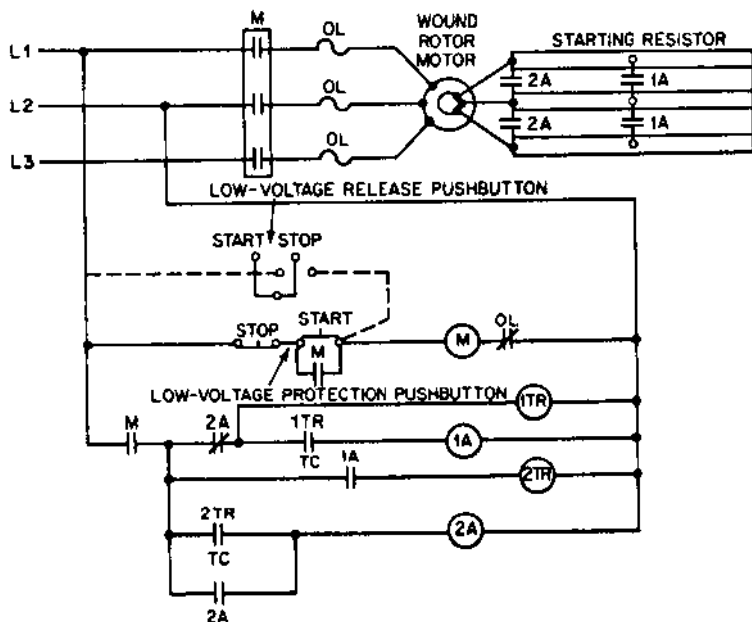


FIGURE 24 Typical wound-rotor motor starter wiring diagram (Westinghouse Electric)

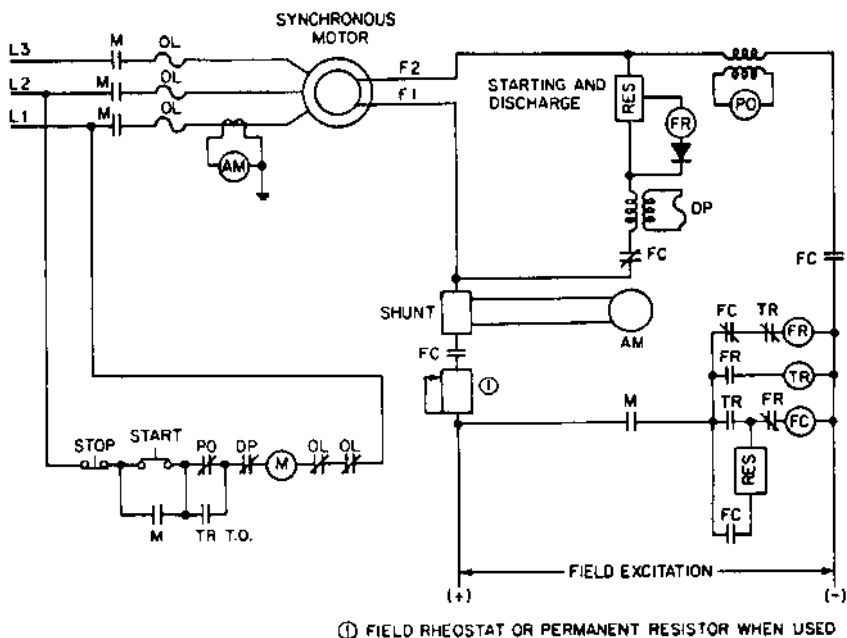


FIGURE 25 Typical synchronous-motor starter wiring diagram (Westinghouse Electric)



Timing relays and contractors progressively short out the resistor until full voltage is on the armature.

If the motor is equipped with a field rheostat for field-range speed adjustment, the starter will apply the preset field voltage as adjusted by the field rheostat after full voltage is applied to the armature.

These starters incorporate a field failure relay to deenergize in the event of field failure and overload relays to protect the motor against overspeed.

The use of dc drives or SCR voltage controllers includes the facilities for all required types of starting conditions for using dc motors for pump applications. Some of these issues are covered in Subsection 6.2.2.

## **SEALLESS PUMP MOTORS**

---

Various centrifugal pump designs are available that require no shaft sealing; that is, no packing or mechanical seal. These pumps are completely leakproof, and some are submersible. Such pumps are used when leakage cannot be tolerated or when pumping conditions such as pressure and/or temperature make conventional sealing difficult, if not impossible.

The shaft seal is eliminated by joining the pump and motor housings together to create a single leakproof unit. The impeller and motor rotor are mounted on a single shaft. Most designs permit the pumped liquid to circulate through the motor rotor and motor bearings. However, there are designs where either circulation is also through the stator or the stator is sealed and filled with dielectric oil. See Subsection 2.2.7.2.

Another popular method used for smaller pumps is to separate the pump shaft completely from the motor shaft. A permanent magnet coupling is provided to transmit the motor torque to the pump shaft through a nonmagnetic shell or section of the pump housing. The pump and motor can be integrated in these designs. See Subsection 6.3.2 and 2.2.7.1.

Figure 26 classifies various motor designs and references other places in the handbook where the special features and applications of these units are described in more detail.

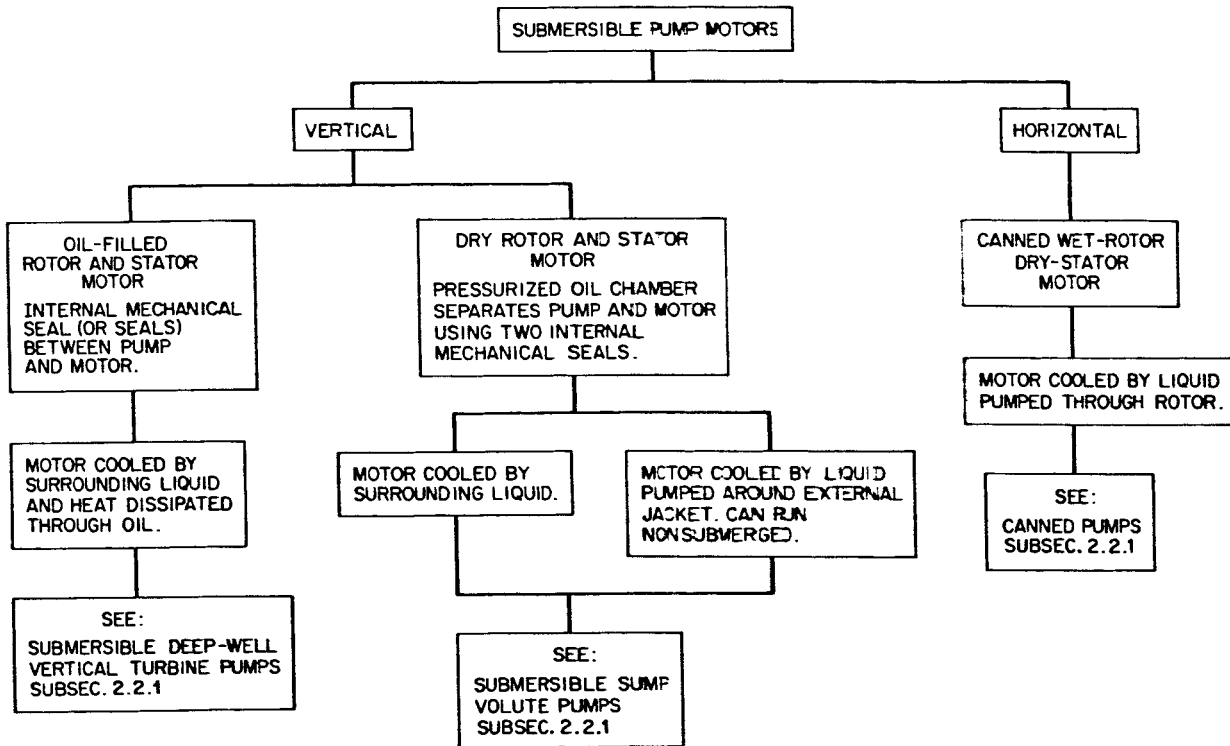


FIGURE 26A Pump motors for sealless centrifugal pumps: Submersible pumps

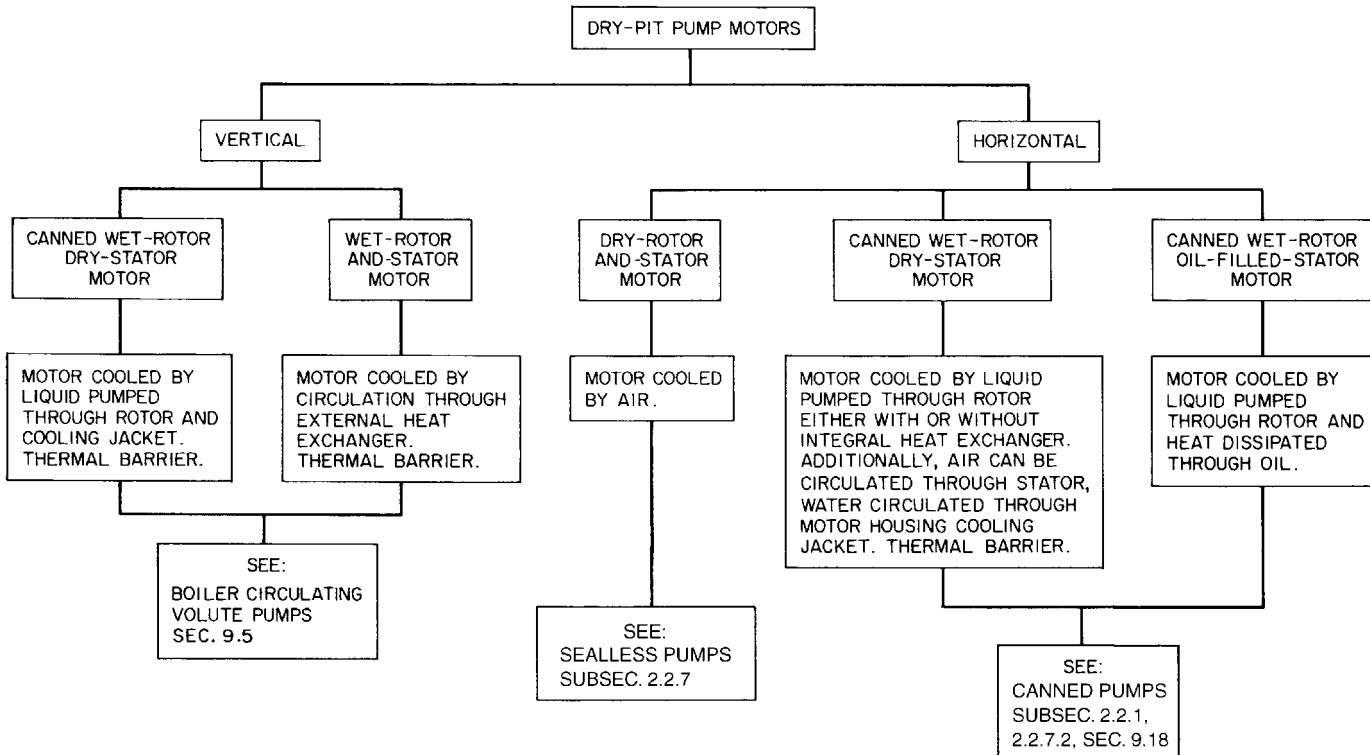


FIGURE 26B Pump motors for sealless centrifugal pumps: Dry pit pumps

**REFERENCES**

---

1. Sloteman, D. P., and Piercy, M. "Developing Sealless Integral Motor Pumps Using Axial Field, Permanent Magnet Disk Motors." *Proceedings of the 17th International Pump Users Symposium*, Texas A&M University, College Station, TX, March 2000, pp. 53–67.

# 6.1.2 STEAM TURBINES

WALLACE L. BERGERON

## **DEFINITIONS**

---

“A steam turbine may be defined as a form of heat engine in which the energy of the steam is transformed into kinetic energy by means of expansion through nozzles, and the kinetic energy of the resulting jet is in turn converted into force doing work on rings of blading mounted on a rotating part.”<sup>1</sup>

This definition may be restated:

“A steam turbine is a prime mover which converts the thermal energy of steam directly into mechanical energy of rotation.”<sup>2</sup>

## **REASONS FOR USING STEAM TURBINES**

---

Steam turbines are used to drive pumps for a variety of reasons:

1. The economical generation of steam often requires boiler steam pressures and temperatures that are considerably in excess of those at which the steam is utilized. Steam may also be used at two or more pressure levels in the same plant. Pressure reduction can be accomplished through valves, pressure-reducing stations, or use of a steam turbine.

Pressure reduction by using a steam turbine and thereby developing power to drive a pump permits lower utility costs. The incremental increase in steam flow and consequently in fuel costs for the same lower pressure steam heating load is in most instances less than the cost of purchased power for a motor-driven pump.

2. A pump driven by a steam turbine may be operated over a wide speed range, utilizing the turbine governor system or a separately controlled valve in the turbine or in the steam line to the turbine. Operation at variable speeds is an inherent characteristic

of steam turbines and does not require the use of special speed-changing devices, as is the case with other prime movers.

The overall efficiency of the turbine and pump unit can be optimized by operating at reduced speeds and at the resultant reduced power ratings. Pump performance can be controlled by reducing the speed of the pump rather than throttling it. Although the turbine efficiency normally declines when operating at a reduced speed, the steam flow will still be less than when the pump is throttled.

Operation at reduced power but at constant speed is also permitted by the speed governor, which throttles the steam to the nozzles as the power is reduced. Efficiency may be improved by equipping the turbine with auxiliary steam valves that are closed for reduced power operation. Closing these valves reduces the available nozzle area and reduces the pressure drop across the governor valve.

When the turbine is operated with the auxiliary steam valve closed, the steam flow will approximate that for the same turbine designed for the reduced rating.

3. The use of a steam turbine driver permits the driven pump to operate essentially independent of the electric power or distribution system. The steam turbine is not affected by electric power stoppages or interruptions and is therefore ideal for critical pumping operations.
4. A turbine may be used as a secondary driver for a pump; it may also drive an independent standby or emergency pump. The particular plant design may not afford sufficient steam for the pump to be normally driven by the steam turbine. However, in the event of an electric power failure or power system disturbance, a steam turbine may be employed as a dual drive or to drive a separate pump to assure continued operation of the plant until the electric power system is again operable.
5. The steam turbine controls—governor system and overspeed trip system—are inherently sparkproof. Consequently, steam turbines can be readily applied to drive centrifugal pumps in a wide variety of hazardous atmospheres without entailing additional cost for explosionproof or sparkproof construction.
6. Steam turbines can normally be readily altered to accommodate an increase in rating for increased pump output or for new pump applications. This inherent flexibility of a steam turbine also permits it to be readily altered to accommodate changes in the initial steam pressure and temperature and in the exhaust steam pressure at which the turbine operates.
7. Steam turbines have a starting, or breakaway, torque of approximately 150 to 180% of the rated torque. Additional starting torque can be readily furnished by designing the turbine for the additional required steam flow—and without reducing the efficiency at the normal operating rating by using an auxiliary steam valve. The additional starting torque can often be obtained without increasing the turbine frame size.
8. Steam turbines can be used to drive all types of pumps.
9. Steam turbines are inherently self-limiting with respect to the power developed. Special protective devices do not have to be furnished to prevent damage to the turbine because of overload conditions. The maximum power that can be developed by a turbine is a function of the flow areas provided in the design of the nozzle ring and governor valve. Application of a load greater than that which can be developed by the turbine causes the turbine to slow down to a speed at which the torque generated by the turbine matches that required by the pump.
10. When the pump application requires the driver to be designed with excess power or to permit operation of the pump “at the end of the curve,” the steam turbine can be designed for the corresponding rating without reducing the turbine efficiency when operating at the normal rating. Closing an auxiliary steam valve furnished for operation at the normal rating preserves efficiency because the turbine governor valve is not throttling to obtain the power rating.
11. With respect to the operation of the various types of pump drivers and their supporting systems, steam turbines afford minimum maintenance, low vibration, and a quiet installation.

## TYPES OF STEAM TURBINES

---

**Single-Stage Turbines** A single-stage steam turbine is one in which the conversion of the kinetic energy to mechanical work occurs with a single expansion of the steam in the turbine—from inlet steam pressure to exhaust steam pressure.

A single-stage turbine may have one or more rows of rotating buckets that absorb the velocity energy of the steam resulting from the single expansion of the steam.

Single-stage turbines are available in wheel diameters of 9 to 28 in (22 to 71 cm). The overall efficiency of a turbine for a particular operating speed and steam conditions is normally dependent on the wheel diameter. The efficiency will generally increase with an increase in wheel size, and therefore the steam rate will be less (for the more usual speeds and steam conditions).

The larger-wheel-diameter steam turbines can be furnished with more nozzles to provide increased steam flow capacity and consequently greater power capabilities. The larger-wheel-diameter turbines are therefore furnished with larger steam connections, valves, shafts, bearings, and so on. Consequently the size of the turbine will generally increase with increases in power rating.

**Multiple-Stage Turbines** A multiple-stage turbine is one in which the conversion of the energy occurs with two or more expansions of the steam in the turbine. The number of stages (steam expansions) is a function of three basic parameters: thermodynamics, mechanical design, and cost. The thermodynamic considerations include the available energy and speed. The mechanical considerations include speed, steam pressure, steam temperature, and so on, most of which are material limits. Cost considerations include the number, type, and size of the stages; the number of governor-controlled valves; the cost of steam; and the number of years used as a basis for the cost evaluation.

The two factors generally used in selecting multistage turbines are initial cost and steam rate. Because these two factors are a function of the total number of stages, the application becomes a factor of stage selection. The initial cost increases with the number of stages, but the steam rate generally improves.

Multiple-stage turbines are normally used to drive pumps when the cost of steam or the available supply of steam requires turbine efficiencies greater than these available with a single-stage turbine, or when the steam flow required to develop the desired rating exceeds the capability of single-stage turbines.

Multiple-stage turbines can be furnished with a single or multiple governor valves. A single governor valve is often of the same design whether used in a single-stage or multiple-stage turbine and generally has the same maximum steam flow, pressure, and temperature parameters. Multiple valves are used when the parameters for a single valve are exceeded or to obtain improved efficiency, particularly at reduced power outputs.

**Shaft Orientation** Some steam turbines, particularly single-stage turbines, can be furnished with vertical downward shaft extensions. The application of such turbines can require considerable coordination between the pump and the turbine manufacturer to assure an adequate thrust bearing in the turbine, shaft length and details, mounting flange dimensions, and even shaft runout.

Vertical shaft pumps are frequently driven by horizontal turbines through a right-angle speed-reduction gear unit.

**Direct-Connected and Geared Turbines** Steam turbines can be directly connected to the pump shaft so the turbine operates at the pump speed or can drive the pump through a speed-reduction (and even speed-increase) gear unit, in order to permit the turbine to operate at a more efficient speed.

**Turbine Stages** The two types of turbine stages are impulse and reaction. The turbines discussed in this subsection employ impulse stages because steam turbines driving pumps normally have impulse-type stages.

In the ideal impulse stage, the steam expands only in the fixed nozzles and the kinetic energy is transferred to the rotating buckets as the steam impinges on the buckets while

flowing through the passages between them. The steam pressure is constant, and the steam velocity relative to the bucket decreases in the bucket passages.

In a reaction stage, the steam expands in both the fixed nozzles and the rotating buckets. The kinetic energy is transferred to the rotating buckets by the expansion of the steam in the passages between the buckets. The steam pressure decreases as the steam velocity relative to the buckets increases in the bucket passages.

In an impulse stage, the steam can exert an axial force on the buckets as it flows through the blade passages. Although this force is usually referred to as a reaction, the use of the term does not imply a reaction-type stage.

The larger buckets used in the last stages of an impulse-type multistage turbine can be of a free-vortex design—twisted and tapered. Such a bucket is ideally subjected to a nearly pure impulse force at its root and a nearly pure reaction force at its tip, but, in reality, this bucket is a high reaction-design bucket compared with a normal impulse-stage bucket. A steam turbine stage with such a bucket design is still referred to as an impulse stage because the primary conversion of kinetic energy is by a reduction rather than an increase in relative steam velocity.

A reaction turbine has more stages than an impulse turbine for the same application because of the small amount of kinetic energy absorbed per stage, and requires a larger thrust bearing or a balancing piston because of the pressure drop across the moving blades. The small pressure drop per stage and the pressure drop across the moving blades require that the steam-leakage losses be minimized by elaborate sealing between the tips of the nozzle blades and the rotor, and the tips of the moving blades and the casing.

The small pressure differential across the rotating blades of an impulse stage results in smaller thrust bearings and no close blade-tip clearances. Consequently impulse turbines can be started more quickly without thermal-expansion damage, and their stage efficiencies remain relatively constant over the life of the turbine.

## CONSTRUCTION DETAILS

**Component Parts** The main components of a single-stage steam turbine are shown in Figure 1.

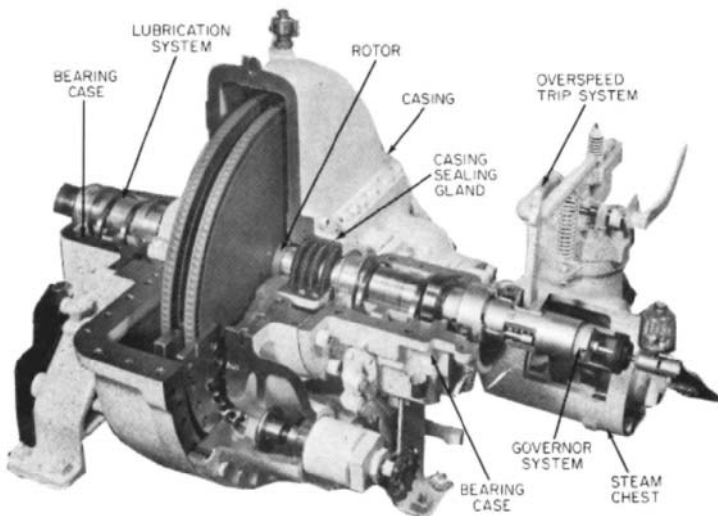


FIGURE 1 Component parts of steam turbines (Elliott)



**Function and Operation—Single-Stage Turbine** The *steam chest* and the *casing* contain the steam furnished to the turbine, being connected to the higher-pressure steam supply line and the lower-pressure steam exhaust line, respectively. The steam chest, which is connected to the casing, houses the governor valve and the overspeed trip valve. The casing contains the rotor and the nozzles through which the steam is expanded and directed against the rotating buckets.

The *rotor* consists of the shaft and disk assemblies with buckets. The shaft extends beyond the casing and through the bearing cases. One end of the shaft is used for coupling to the driven pump. The other end serves the speed governor and the overspeed trip systems.

The *bearing cases* support the rotor and the assembled casing and steam chest. The bearing cases contain the journal bearings and the rotating oil seals, which prevent outward oil leakage and the entrance of water, dust, and steam. The steam end bearing case also contains the rotor positioning bearing and the rotating components of the overspeed trip system. An extension of the steam end bearing housing encloses the rotating components of the speed governor system.

The *casing sealing glands* seal the casing and the shaft with spring-backed segmented carbon rings (supplemented by a spring-backed labyrinth section for the higher exhaust steam pressures).

The *governor system* commonly consists of spring-opposed rotating weights, a steam valve, and an interconnecting linkage or servomotor system. Changes in the turbine inlet and exhaust steam conditions, and the power required by the pump will cause the turbine speed to change. The change in speed results in a repositioning of the rotating governor weights and subsequently of the governor valve.

The *overspeed trip system* usually consists of a spring-loaded pin or weight mounted in the turbine shaft or on a collar, a quick-closing valve that is separate from the governor valve, and interconnecting linkage. The centrifugal force created by rotation of the pin in the turbine shaft exceeds the spring loading at a preset speed. The resultant movement of the trip pin causes knife edges in the linkage to separate and permit the spring-loaded trip valve to close.

The trip valve may be closed by disengaging the knife edges manually, by an electric or pneumatic signal, by low oil pressure, or by high turbine exhaust steam pressure.

The two usual types of lubrication systems are oil-ring and pressure. The *oil-ring* lubrication system employs an oil ring(s) that rotates on the shaft with the lower portion submerged in the oil contained in the bearing case. The rotating ring(s) transfers oil from the oil reservoir to the turbine shaft journal bearing and rotor-locating bearing. The oil in the bearing case reservoirs is cooled by water flowing in cooling water chambers or tubular heat exchangers.

A *pressure* lubrication system consists of an oil pump driven from the turbine shaft, an oil reservoir, a tubular oil cooler, an oil filter, and interconnecting piping. Oil is supplied to the bearing cases under pressure. The oil rings may be retained in this system to provide oil to the bearings during startup and shutdown when the operating speed and bearing design permit.

Typical sectional drawings are shown in Figures 2, 3, and 4.

## GOVERNORS AND CONTROLS

---

Governor systems are typically speed-sensitive control systems. The turbine speed is controlled by varying the steam flow through the turbine by positioning the governor valve. Variations in the power required by the pump and changes in steam inlet or exhaust conditions alter the speed of the turbine, causing the governor system to respond to correct the operating speed.

Control systems, unlike governor systems, are not directly speed-sensitive but respond to changes in pump or pump-system pressures and then reposition the turbine “governor” valve to maintain the preset pressure. Consequently, changes in turbine steam conditions or in the power required by the pump result in a repositioning of the turbine governor

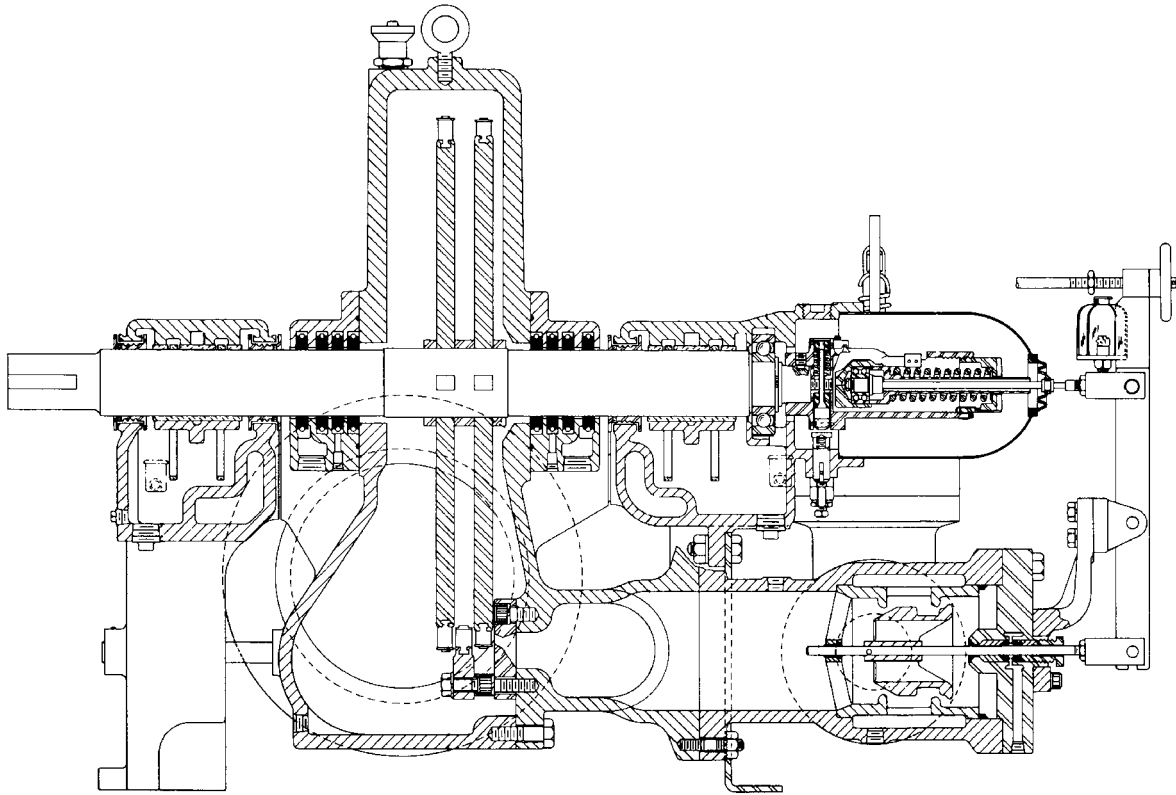


FIGURE 2 Section of single-stage turbine and governor system (Elliott)

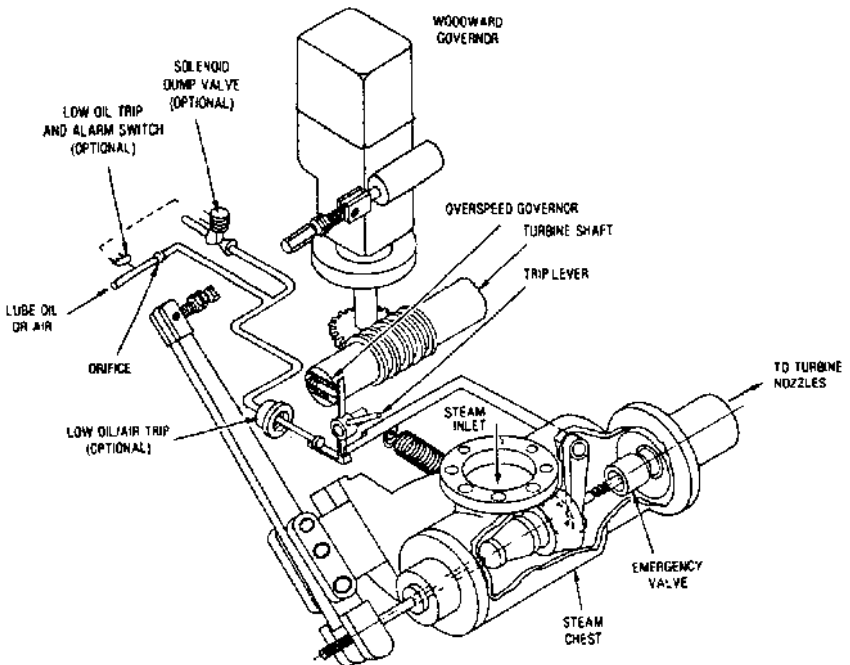


FIGURE 3 Typical turbine overspeed trip arrangement (Dresser-Rand).

valve or of a separate steam valve only after the pressure being sensed by the controller has changed.

Even when a control system is furnished, a speed governor is also normally furnished. The speed governor is set for a speed slightly higher than the desired operating speed in order to function as a pre-emergency governor; that is, prevent the turbine from reaching the trip speed when the controller causes the turbine to operate at a speed above rated speed.

Governor systems are defined by their performance as follows:<sup>2</sup>

Class of governor system	Speed range, % (as specified)	Maximum speed regulation, %	Maximum speed variation, %, ±	Maximum speed rise, %
A	10–65	10	0.75	13
B	10–80	6	0.50	7
C	10–80	4	0.25	7
D	10–90	0.50	0.25	7

*Speed range* is the percentage below rated speed for which the governor speed setting may be adjusted. For example, a turbine with 4000 rpm rated speed and a governor system having a 30% range can be operated at a minimum speed of 2800 rpm:

$$4000 - \frac{30 \times 4000}{100} = 2800$$

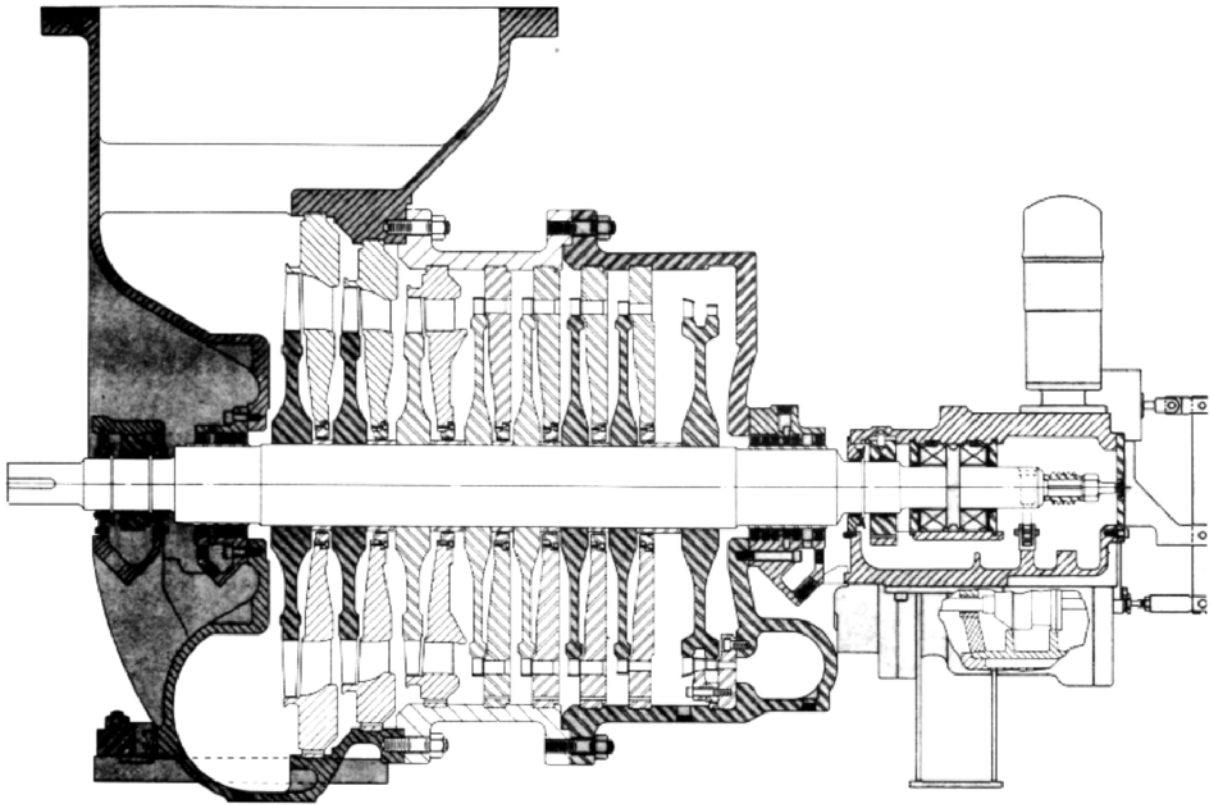


FIGURE 4 Section of multistage turbine (Elliot)

If the speed range had been specified as plus 5% and minus 25%, for example, the maximum and minimum speeds would be 4200 and 3000 rpm.

*Steady-state speed regulation* is the change in speed required for the governor system to close the governor valve when the load is gradually reduced from rated load to no load with turbine steam conditions constant. Regulation is always expressed as a percentage of rated speed and calculated as follows:

$$\frac{\text{No-load speed} - \text{rated speed}}{\text{Rated speed}} \times 100 = \% \text{ regulation}$$

Therefore

$$\text{No-load speed} = \text{rated speed} \left( 1 + \frac{\% \text{ regulation}}{100} \right)$$

A turbine with 4000 rpm rated speed and equipped with a NEMA A speed governor system would have 4400 rpm maximum no-load speed:

$$4000 \times \left( 1 + \frac{10}{100} \right) = 4400 \text{ rpm}$$

Consequently, whenever the turbine is developing less than rated power, the operating speed will be greater than rated speed, as required for the governor system to reposition the governor valve.

*Speed variation*, expressed as a percentage, is the total magnitude of the fluctuations from the set speed permitted by the governor system when the turbine is normally operating at rated speed, power, and steam conditions. This is the “insensitivity” of the governor system. The speed variation equation is

$$\frac{\text{Maximum speed} - \text{minimum speed}}{\text{Rated speed} \times 2} \times 100 = \pm \% \text{ speed variation}$$

A turbine with 4000 rpm rated speed and NEMA A governor system would have  $\pm 30$  rpm maximum speed variation:

$$4000 \times \frac{\pm 0.75}{100} = \pm 30 \text{ rpm}$$

*Maximum speed rise* represents the momentary increase in speed when the load is suddenly reduced from rated power to no-load power with the pump still coupled to the turbine shaft. Shortly after the sudden loss of load, the governor system will cause the turbine speed to be reduced to the no-load speed.

Maximum speed rise is also expressed as a percentage of rated speed and calculated as follows:

$$\frac{\text{Maximum speed} - \text{rated speed}}{\text{Rated speed}} \times 100 = \% \text{ speed rise}$$

Therefore

$$\text{Maximum speed} = \text{rated speed} + \frac{\text{rated speed} \times \% \text{ speed rise}}{100}$$

A turbine with 4000 rpm rated speed and equipped with a NEMA A governor will have a maximum speed rise to

$$4000 + \frac{4000 \times 13}{100} = 4520 \text{ rpm}$$

The setting of the *overspeed trip* is a function of the maximum speed rise of the governor system—it must be higher than the maximum speed rise. The recommended settings are

Class of governor system	Overspeed trip setting, (% of rated speed)
A	115
B	110
C	110
D	110

The overspeed trip system for a turbine with 4000 rpm rated speed and equipped with a NEMA A governor is set for operation at

$$4000 \times \frac{115}{100} = 4600 \text{ rpm}$$

The speed-sensitive portion of the speed governor system is usually a set of spring-loaded rotating weights. Movement of the weights caused by a change in turbine speed positions the governor valve through a suitable linkage.

The speed-sensitive element can also be other devices that are speed-responsive, such as a positive displacement oil pump, electric generator, or a magnetic impulse signal generator.

The rotating-weight governor system is a direct-acting type and is classified as a NEMA A governor. *Direct-acting* designates a governor system in which the speed-sensitive element also provides the power for positioning the governor valve.

The NEMA B, C, and D governor systems have speed-sensitive elements that position the governor valve through a relay or servomotor system instead of actuating the valve directly. The speed-sensitive element can therefore be more precise and sensitive, as required for the improved governor system performance.

Electronic governors with pneumatic/hydraulic actuators are also available that offer more control, flexibility, and speed adjustment as well as other operating modes.

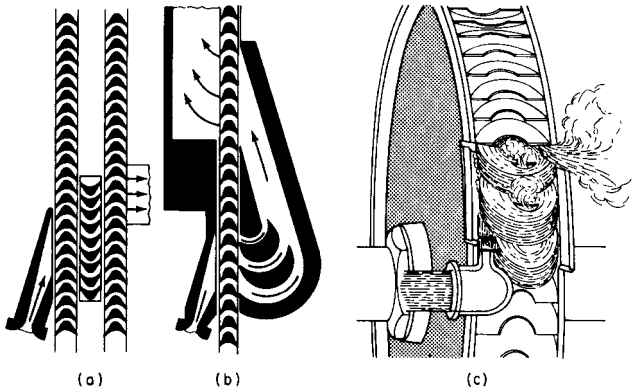
## THEORY

A steam turbine develops mechanical work by converting to work the available heat energy in the steam expansion. Heat and mechanical work, being two forms of energy, can be converted from one to the other.

The heat energy is converted in two steps. The steam expands in nozzles and discharges at a high velocity, converting the available heat energy to velocity (kinetic) energy. The high-velocity steam strikes moving blades, converting the velocity energy to work. Because the total heat energy available in the steam is converted to velocity (kinetic) energy, the magnitude of the steam velocity is dependent upon the available energy.

The mechanical work that is developed in the turbine by the high-velocity steam striking the buckets is a function of the speed of the buckets. Maximum work occurs when the bucket velocity is approximately one-half the steam jet velocity for an impulse stage and one-fourth the steam jet velocity for a velocity-compounded impulse stage. Although the steam jet velocity is fixed by the available heat energy, the bucket velocity is fixed by the speed of the turbine and the diameter of the turbine wheel on which the buckets are mounted. The work developed, or the efficiency of the turbine, ignoring losses in the turbine, is therefore determined by the size of the turbine and the turbine (pump) speed for a fixed amount of available heat energy.

The most common single-stage turbine is the velocity-compounded (Curtis) type. The complete expansion from inlet to exhaust pressure occurs in one step. The Curtis stage,



**FIGURE 5** Velocity-compounded stages: (a) Curtis stage; steam flows once through moving buckets; (b) re-entry stage; steam flows twice through moving buckets; (c) re-entry stage; steam flows three times through moving buckets (reprinted with permission from *Power*, June 1962)

with two rows of rotating buckets, and two re-entry-type velocity-compounded stages are illustrated in Figure 5.

Single-stage turbines are available with a wide range of efficiencies because they are manufactured with a variety of wheel diameters: 9 to 28 in (22 to 71 cm).

Multistage turbines are manufactured with a more limited variety of wheel sizes. The efficiency of multistage turbines is varied primarily by varying the number of stages. When the total available energy of the steam results in a steam velocity greater than twice the bucket velocity (using convenient wheel sizes), a multistage turbine will be more efficient. In a multistage turbine, the total steam expansion is divided among the various impulse stages to produce the desired steam velocity for each row of buckets.

A steam turbine is normally evaluated using *steam rate*—the amount of steam required by the turbine to produce the specified power per hour at the specified speed—rather than *efficiency*. The steam rate is a direct function of the turbine efficiency.

The steam consumption can be expressed either as steam rate, pounds of steam per horsepower-hour (kilograms per kilowatt-hour) or as steam flow, pounds of steam per hour (kilograms per hour). The higher the efficiency, the lower the steam rate or steam flow, and vice versa.

The total available energy of the steam is that available from an isentropic expansion. For given initial steam pressure and temperature and exhaust pressure, the available energy in British thermal units per pound (kilojoules per kilogram) of steam can be obtained from the tables or the Mollier chart in Reference 3.

The available energy can be converted to power units and expressed as the theoretical steam rate—pounds per horsepower-hour or pounds per kilowatt-hour (kilograms per kilowatt-hour). The theoretical steam rate is the steam rate for a 100% efficient turbine and therefore can be used more conveniently than energy in British thermal units per pound (kilojoules per kilogram) for the calculation of turbine steam rates. Theoretical steam rates can be obtained directly from theoretical steam rate tables (ASME) or from the polar Mollier chart (Elliott Company).

The actual steam rate for a turbine is greater than the theoretical steam rate because of the losses that occur in the turbine when the available energy is converted to mechanical work and because of the ratio of the steam velocity to bucket velocity. The energy remaining in the steam exhausting from the turbine is greater than that after an isentropic expansion, as illustrated in Mollier diagram shown in Figure 6, where

- 1 = energy in steam at initial steam pressure and temperature
- 2 = energy in steam at exhaust pressure for an isentropic expansion
- 3 = actual energy in steam at exhaust pressure

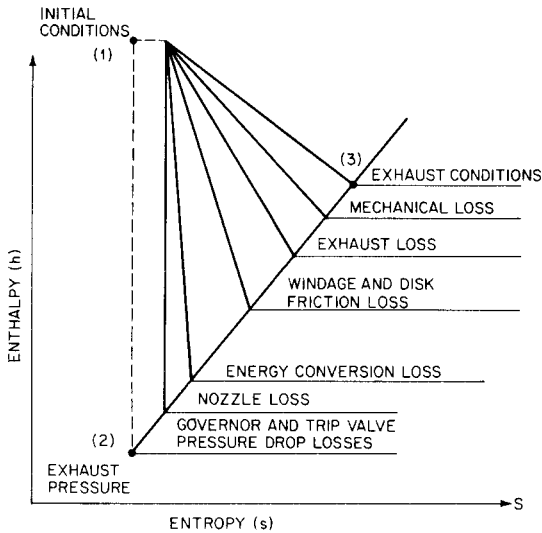


FIGURE 6 Mollier diagram with energy losses

The efficiency of the turbine is

$$\frac{h_1 - h_3}{h_1 - h_2} \quad \text{or} \quad \frac{\text{theoretical steam rate}}{\text{actual steam rate}}$$

The governor and trip valve pressure drop losses are a function of the sizes of these two valves and the steam flow. The governor valve pressure drop will vary more than the trip valve pressure drop because of changes in valve position with power required by the driven pump, speed variations, and changes in inlet and exhaust steam conditions.

The nozzle loss is due to friction in the nozzles as the steam expands. The efficiency of the nozzles is a function of the ratio of the actual and ideal exit steam velocities squared. The efficiency is usually between 95 and 99%.

The windage and disk friction losses are due to the friction between the stream and the disks and the blades fanning the steam. This loss varies inversely with the specific volume of the steam, increases with exhaust pressure, and increases with the diameter of the wheel and the length of the blades.

The use of a larger-diameter wheel may increase the efficiency, but the windage and disk friction losses will reduce the improvement and may even cause a net loss in overall efficiency.

The exhaust losses represent the kinetic energy remaining in the steam as a result of the velocity of the steam leaving the bucket and the pressure drop in the steam as it passes out the exhaust connection.

The energy conversion loss is due to the nonideal conversion of the steam velocity energy to mechanical work in the buckets as a function of the steam velocity and bucket velocity, plus nonideal nozzle and bucket angles, friction in the system, and so on.

The performance that can be expected from a single-stage Curtis-type turbine may be obtained from Figures 7, 8, and 9, and Table 1 after determining the theoretical steam rate.

$$\text{Steam rate} = \frac{\text{base steam rate}}{\text{superheat correction factor}} \times \frac{\text{power} + \text{power loss}}{\text{power}}$$

To obtain superheat, subtract temperature given in Table 1 from total initial temperature.



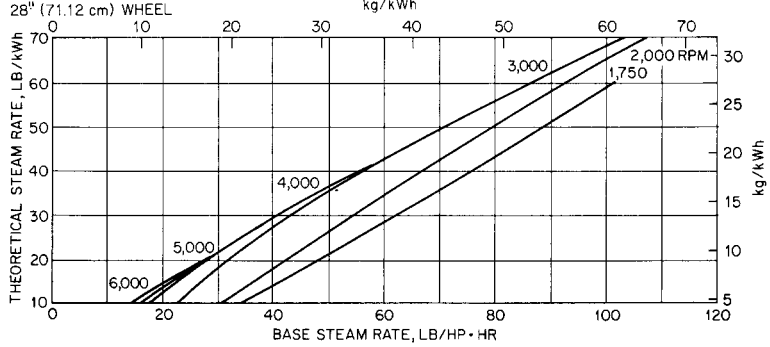
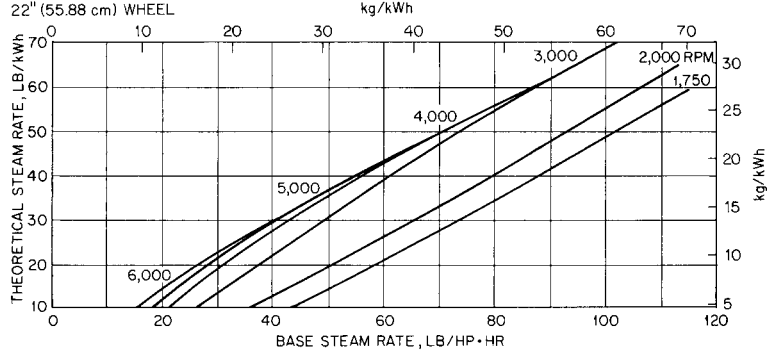
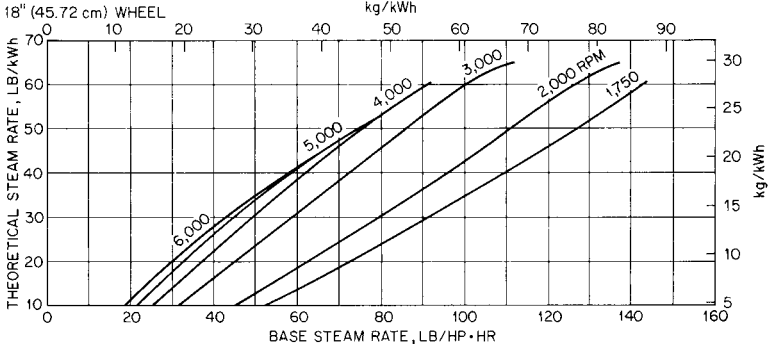
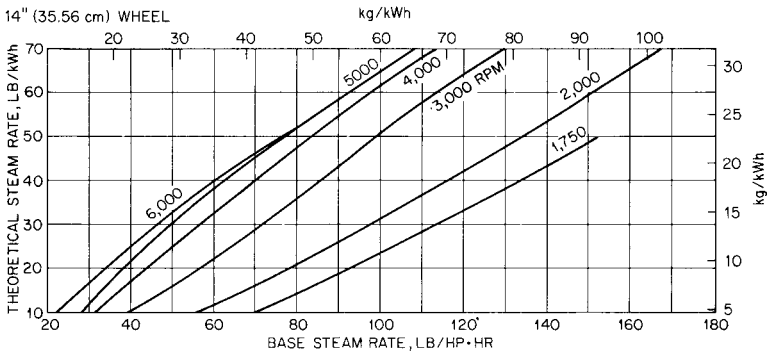


FIGURE 7 Base steam rates (Elliott)

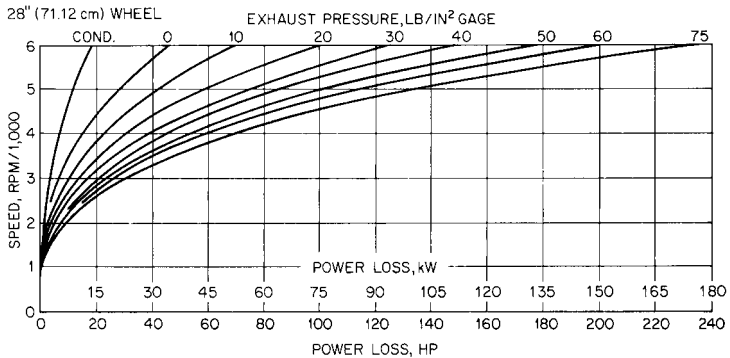
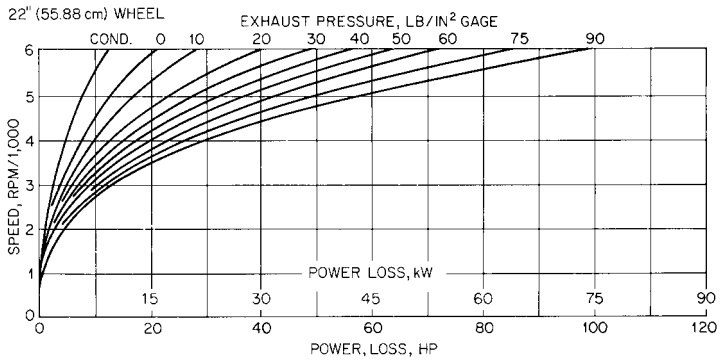
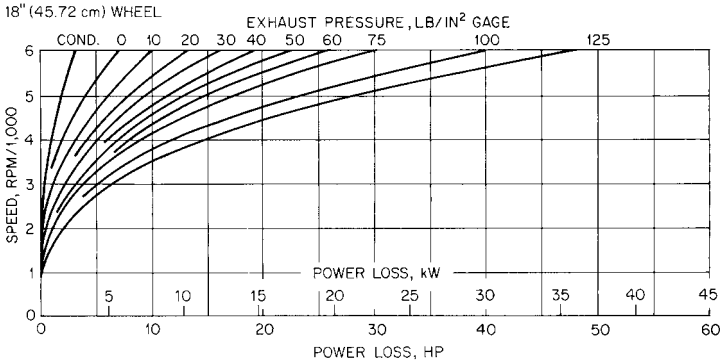
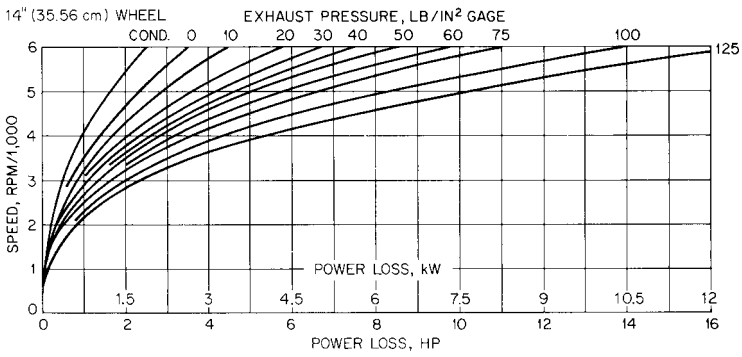


FIGURE 8 Power loss (lb/in<sup>2</sup> × 6.895 = kPa) (Elliott)

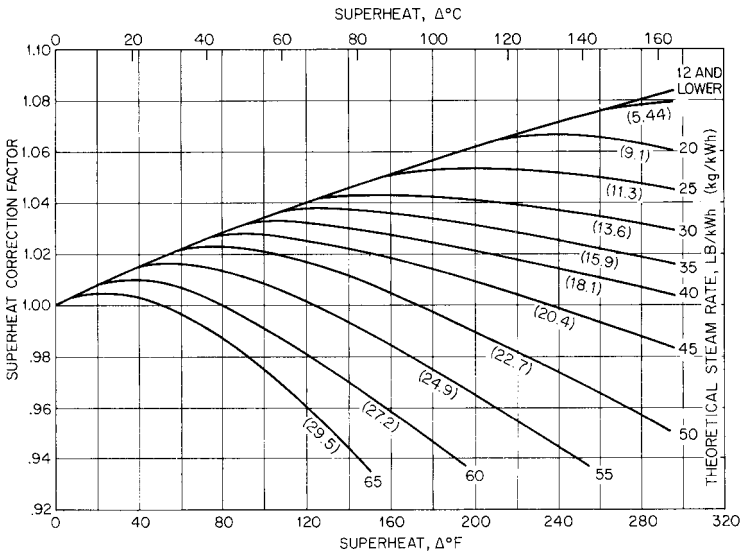


FIGURE 9 Superheat correction factor (Elliott)

### SAMPLE CALCULATION

STEAM CONDITIONS 250 lb/in<sup>2</sup> (1724 kPa) gage inlet, 575°F (302°C) inlet, and 50 lb/in<sup>2</sup> (345 kPa) gage exhaust.

DESIGN CONDITIONS turbine to develop 500 hp (373 kW) at 4000 rpm.

1. Theoretical steam rate = 26.07 lb/kWh (11.82 kg/kWh)
2. Base steam rate for 28-in (71.12-cm) wheel (Figure 7) = 36 lb/hp · h (22 kg/kWh)
3. Power loss for 28-in (71.12-cm) wheel (Figure 8) = 55 hp (41 kW)
4. Temperature of dry and saturated inlet steam (Table 1) = 406°F (208°C)
5. Superheat (Table 1) = 575 – 406 = 169Δ°F (302 – 208 = 94Δ°C)
6. Superheat corrections factor (Figure 9) = 1.052
7. Steam rate =

$$\text{In USCS units} \quad \frac{36}{1.052} \times \frac{500 + 55}{500} = 38.0 \text{ lb/hp} \cdot \text{h}$$

$$\text{In SI units} \quad \frac{21.89}{1.052} \times \frac{373 + 41}{373} = 23.1 \text{ kg/kWh}$$

The ability of a particular size turbine to develop the required power is determined primarily by

1. The flow capacity of the inlet and exhaust connection from Figures 10 and 11, where steam flow = power × steam rate
2. The flow capacity of the nozzles available in a particular turbine (the number and size of the nozzles vary considerably with each design of turbine manufactured, and thus a meaningful plot cannot be included here).

**TABLE 1** Temperature of dry and saturated steam

Lb/in <sup>2</sup> gage	Saturation temp., °F	Lb/in <sup>2</sup> gage	Saturation temp., °F	Lb/in <sup>2</sup> gage	Saturation temp., °F	Lb/in <sup>2</sup> gage	Saturation temp., °F
0	213	150	366	300	422	450	460
5	228	155	368	305	423	455	461
10	240	160	371	310	425	460	462
15	250	165	373	315	426	465	463
20	259	170	375	320	428	470	464
25	267	175	378	325	429	475	465
30	274	180	380	330	431	480	466
35	281	185	382	335	432	485	467
40	287	190	384	340	433	490	468
45	293	195	386	345	434	495	469
50	298	200	388	350	436	500	470
55	303	205	390	355	437	510	472
60	308	210	392	360	438	520	474
65	312	215	394	365	440	530	476
70	316	220	396	370	441	540	478
75	320	225	397	375	442	550	480
80	328	230	399	380	444	560	482
85	328	235	401	385	445	570	483
90	331	240	403	390	446	580	485
95	335	245	404	395	447	590	487
100	338	250	406	400	448	600	489
105	341	255	408	405	449	610	491
110	344	260	410	410	451	620	492
115	347	265	411	415	452	630	494
120	350	270	413	420	453	640	496
125	353	275	414	425	454	650	497
130	356	280	416	430	455	660	499
135	358	285	417	435	456	670	501
140	361	290	419	440	457	680	502
145	364	295	420	445	458	690	504

To obtain superheat, subtract temperature given above from total initial temperature. Pressure in kPa =  $6.895 \times \text{lb/in}^2$ . Temperature in °C =  $(\text{°F} - 32) \div 1.8$ .

## EVALUATION OF COSTS

The economical selection of a turbine considers the initial cost of the turbine and the operating costs. A lower-steam-rate (more efficient) turbine generally has a higher initial cost than a turbine with a higher steam rate. The operating costs are the cost of the steam for the number of years upon which the evaluation is to be based:

$$\text{Total cost} = \text{initial cost} + \left( \text{power} \times \frac{\text{steam rate}}{\text{rate}} \times \frac{\text{steam cost}}{\text{cost}} \times \frac{\text{operating hours}}{\text{per year}} \times \frac{\text{number}}{\text{of years}} \right)$$

The cost of installation—foundation, steam piping, and cooling water service (also electric service if required)—is not normally considered unless there are significant differences between the turbines: single-stage versus multistage, direct-connected versus turbine and gear, vertical turbine versus horizontal turbine with a right-angle gear, and so on.

The economical selection of a steam turbine versus an electric motor, diesel engine, gas engine, gas turbine, and so on, must include an evaluation of all installation costs, costs of

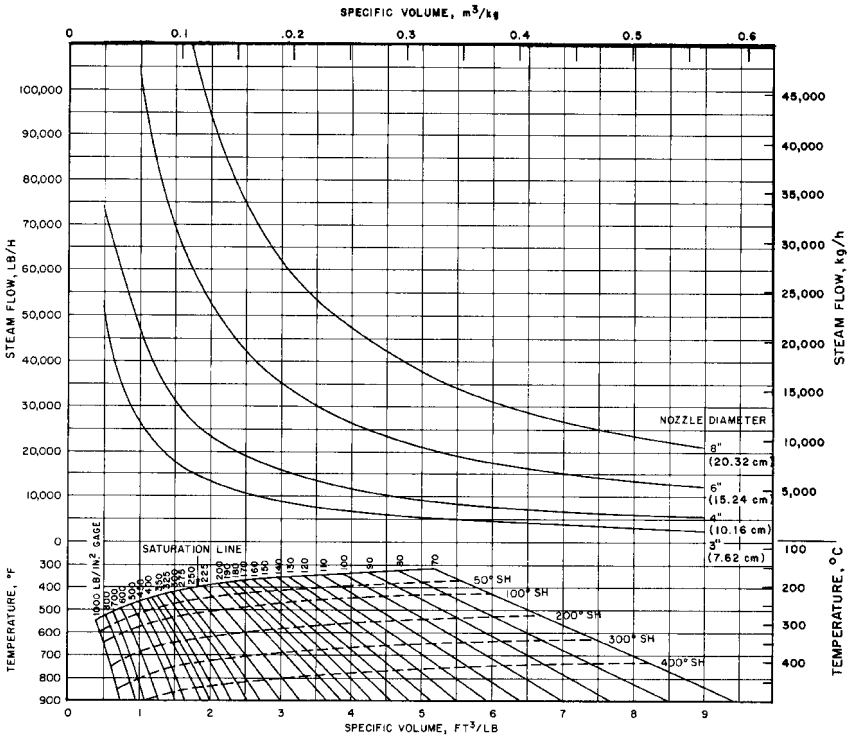


FIGURE 10 Nominal inlet flow capacity. Read inlet nozzle size required to pass maximum flow, based on 150-ft/s (45.7-m/s) steam velocity ( $lb/in^2 \times 6.895 = kPa$ ;  $^{\circ}F_{SH} \times 0.555 = ^{\circ}C_{SH}$ )

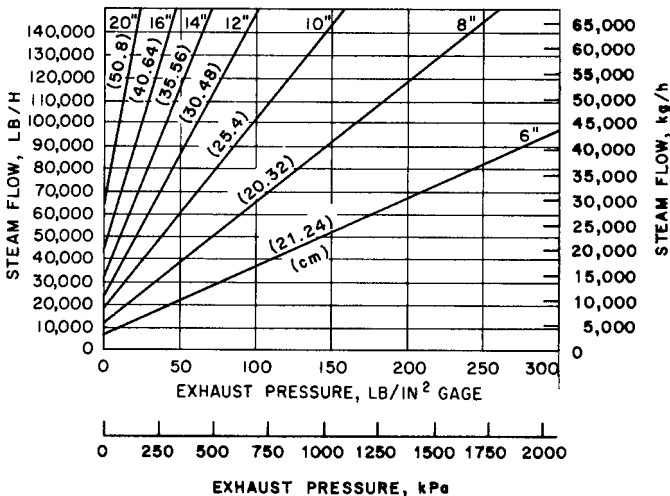
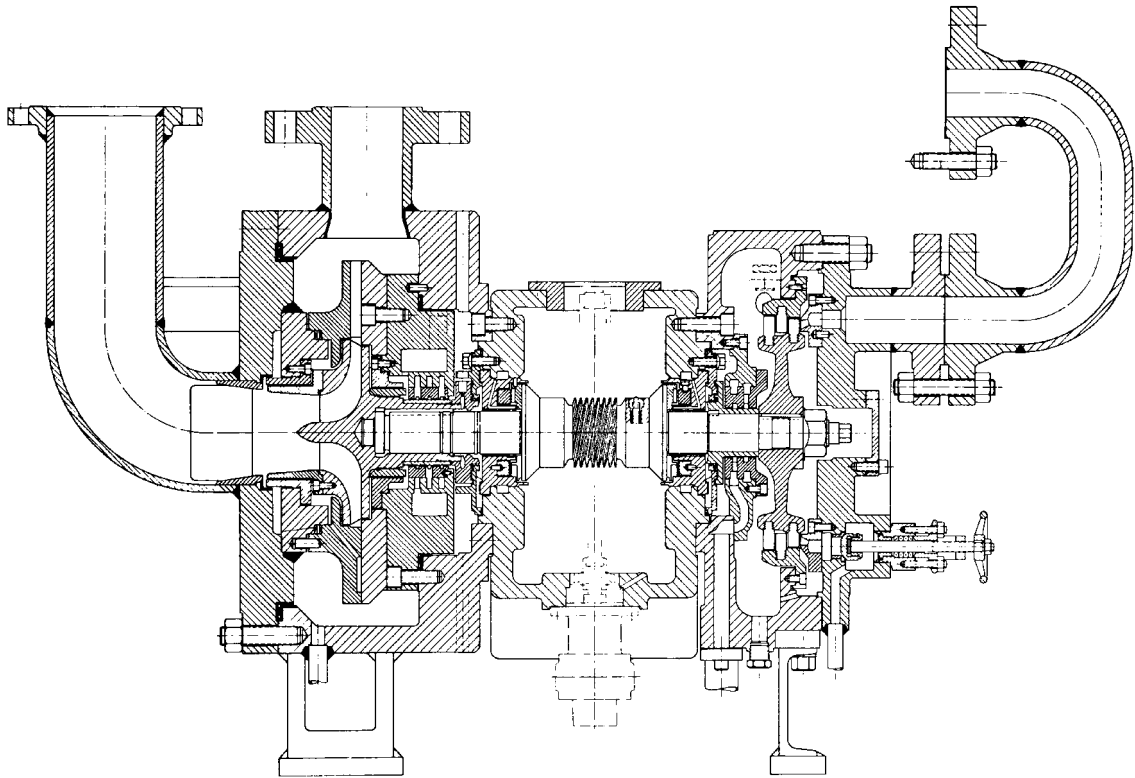


FIGURE 11 Nominal exhaust flow capacity. Noncondensing exhaust nozzles, based on 200-ft/s (61 m/s) steam velocity



**FIGURE 12** High-speed centrifugal pump and single-stage steam turbine mounted on a common shaft. Package is designed for boiler feed in marine, industrial, and process steam plants (Flowsolve Corporation).

supporting equipment (starters, switch gear, fuel-supply system, and so on), operating costs, and the initial costs of the various drivers being considered.

## REFERENCES

---

1. Church, E. F. *Steam Turbines*. McGraw-Hill, New York, 1950.
2. "Single-Stage Steam Turbines for Mechanical Drive Service." NEMA pub. SM22-1970, 1970.
3. Keenan, J. H., and Keyes, F. G. "Thermodynamic Properties of Steam." John Wiley & Sons, Inc., New York, 1936.

## FURTHER READING

---

- Bergeron, W. L. "Governors and Controls: Each Has Specific Operation." *Sugar J.*, March 1965.
- "Multistage Steam Turbines for Mechanical Drive Service." NEMA pub. SM21-1970, 1970.
- Skrotzki, B. G. A. "Steam Turbines." *Power* special report, 1962.
- Steen-Johnsen, H. "Here's What You Should Know Before You Specify Control Systems for Mechanical Drive Steam Turbines." *Power Eng.*, February–March 1966.
- Steen-Johnsen, H. "How to Estimate the Size and Cost of Mechanical Drive Steam Turbines." *Hydrocarbon Processing*, October 1967.
- Steen-Johnsen, H. "Mechanical Drive Turbines." *Oil Gas Equip.*, March, April, May, 1967.
- Steen-Johnsen, H. "Selecting the Right Steam Turbine for Industrial Use." *Power Eng.*, April 1965.
- "Theoretical Steam Rate Tables." ASME, 1969.

# 6.1.3 ENGINES

F. J. GUNTHER

## **ENGINE SELECTION AND APPLICATION**

---

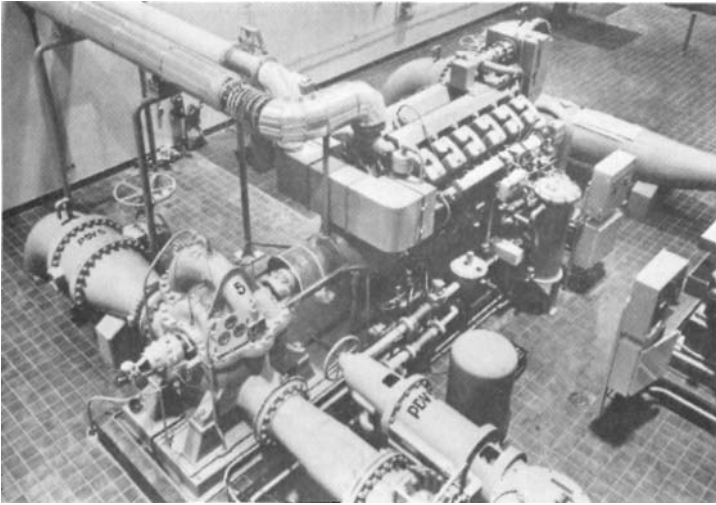
The internal combustion engine is used extensively as a driver for centrifugal and displacement pumps. Depending on the application, the engine fuel may be gasoline, natural gas, liquid petroleum gas (LPG), sewage gas, or diesel fuel. It may be either liquid- or air-cooled.

**Basic Design Variations** The basic design of the engine may vary. The cylinder block construction is vertical or horizontal, in-line or V-type. The number of cylinders ranges from 1 to 20. The engine cycle is either four (one power stroke in two revolutions of the crankshaft) or two (one power stroke in one revolution of the crankshaft). The combustion chamber and cylinder head design are classed as L-head (valves in the cylinder block) or valve-in head. In the diesel engine, the combustion chamber may be of the precombustion chamber design, where an ante chamber is used to initiate combustion, or of the direct injection design, where the fuel is injected directly into the cylinder. The piston design action may be vertical, horizontal, at an angle as in the V-type engine, or opposed piston (two pistons operating in the same cylinder).

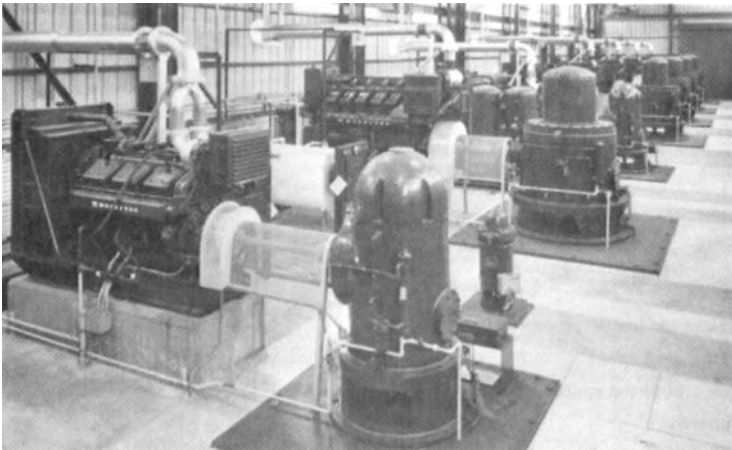
**Power Ratings** The power range of engines in current production, depending on displacement, number of cylinders, and speed, is as follows:

1. Air-cooled gasoline, natural gas, and diesel: 1.0 to 75 hp (0.75 to 56 kW)
2. Liquid-cooled gasoline: 10 to 300 hp (75 to 224 kW)
3. Liquid-cooled natural gas, LPG, and sewage gas: 10 to 15,000 hp (75 to 11,200 kW)
4. Liquid-cooled diesel: 10 to 50,000 hp (75 to 37,300 kW)
5. Dual fuel, natural gas, LPG, and diesel: 150 to 25,000 hp (112 to 18,700 kW)





**FIGURE 1** Natural gas engine driving a horizontal water pump for Winnipeg, Canada, water utility (Waukesha Motor)



**FIGURE 2** Diesel engine driving pumps for flood-control station in Seattle (Waukesha Motor)

Typical engine driver applications are represented in Figures 1 and 2.

The rating of the internal combustion engine is the most important consideration in making the proper selection. The general practice is to rate engines according to the severity of the duty to be performed. The most common rating classifications are maximum, standby or intermittent, and continuous.

The maximum output is based on dynamometer tests that are corrected to standard atmospheric conditions for temperature and barometric pressure. In applications, this power rating is reduced by accessories such as cooling fans, air cleaners, and starting systems.

Standby, or intermittent, and continuous ratings are arrived at by applying a percentage factor to the net maximum power rating. For example, 75 to 80% is used for continuous and 90% for intermittent.

*Duty cycle* is a term used to describe the load pattern imposed on the engine. If the load factor (ratio of average load to maximum capabilities) is low, we call the duty cycle “light,” but if it is high, we classify the cycle “heavy.” Continuous, or heavy-duty, service is generally considered to be 24 h/day, with little variation in load or speed. Intermittent service is classified as duty where an engine is called upon to operate in emergencies or at reduced loads at frequent intervals.

In analyzing power problems when selecting a proper engine, certain terms are used in the industry:

**DISPLACEMENT** The displacement in cubic inches (cubic centimeters) of an engine cylinder is

In USCS units,  $D = \text{bore (in)}^2 \times 0.7854 \times \text{stroke (in)} \times \text{no. of cylinders}$

In SI units  $D = \text{bore (cm)}^2 \times 0.7854 \times \text{stroke (cm)} \times \text{no. of cylinders}$

**Torque** The twisting effort of the engine in pound-feet (Newton-meters) is

In USCS units  $T = 5252 \times \frac{\text{bhp}}{\text{rpm}}$

In SI units  $T = 9545 \times \frac{\text{bkW}}{\text{rpm}}$

**ENGINE POWER** This is a measure of the theoretical characteristics of an engine. Brake horsepower (bkW) is the measurable power after the deduction for frictional losses:

In USCS units  $\text{bhp} = T \times \frac{\text{rpm}}{5252}$

In SI units  $\text{bkW} = T \times \frac{\text{rpm}}{9545}$

**BRAKE MEAN EFFECTIVE PRESSURE** The average cylinder pressure to give a resultant torque at the flywheel in pounds per square inch (kilopascals)

In USCS units  $\text{bmeP} = \frac{792,000 \times \text{bhp}}{\text{rpm} \times D}$  (four-cycle)

$$\text{bmeP} = \frac{396,000 \times \text{bhp}}{\text{rpm} \times D}$$
 (two cycle)

In SI units  $\text{bmeP} = \frac{120 \times 10^6 \times \text{bkW}}{\text{rpm} \times D}$  (four-cycle)

$$\text{bmeP} = \frac{60 \times 10^6 \times \text{bkW}}{\text{rpm} \times D}$$
 (two cycle)

**PISTON SPEED** At a given speed, the average velocity of piston in feet per minute (centimeters per minute) is

In USCS units  $\text{Piston speed} = \text{stroke (in)} \times 2 \times \frac{\text{rpm}}{12}$

In SI units  $\text{Piston speed} = \text{stroke (cm)} \times 2 \times \frac{\text{rpm}}{6000}$

In selecting an engine for a particular application, the following variables should be considered:

- Altitude
- Ambient air temperature

- Rotation and speed
- Bmep and piston speed
- Maintenance
- Type of fuel
- Operating atmosphere (dust and dirt)
- Vibrations and torsionals
- Engine pollutants

The observed power is that produced by an engine at the existing altitude and temperature. All engine manufacturers publish power ratings corrected to certain conditions; for conditions other than these, it is necessary to correct by applying a percentage factor for altitude and temperature. Generally this is  $3\frac{1}{2}\%$  per thousand feet (305 m) above sea level and 1% for every  $10^{\circ}\text{F}$  ( $5.6^{\circ}\text{C}$ ) above  $60^{\circ}\text{F}$  ( $50.4^{\circ}\text{C}$ ). In a turbocharged engine, there is no established standard and the engine manufacturer should be consulted.

The basic rotation of engines in current production is counterclockwise when viewed from the flywheel end of the engine, although many of the larger engines are available in both counterclockwise and clockwise rotation. The speed of the engine is generally fixed by the equipment being driven. Through the use of speed-increasing or -reducing gear boxes, the proper engine for a given application may be selected. A gear box may also be used to correct a rotation problem.

Speed ranges for engines generally fall into three categories:

- High—above 1500 rpm
- Medium—700 to 1500 rpm
- Low—below 700 rpm

High-speed engines generally offer weight and size advantages as well as cost savings and thus are used for standby applications. On the other hand, medium- or low-speed engines, although heavier and larger, offer a gain in service life and lower maintenance costs.

The speed flexibility of an engine drive is important when the engine is to be used to drive a pump that must move variable quantities of liquid. The engine speed may be changed very simply either manually or through the use of liquid or pressure controls.

Bmep is generally a measure of load, and piston speed a measure of potential wear and maintenance. Although the introduction of the turbocharged and intercooled engine has somewhat changed the consideration given these factors, it is still important to consider them in selecting engines where long life is a factor.

Maintenance of engines has been considered by some as objectionable and more costly than electric power. A recent innovation of engine manufacturers, in the form of a service contract for installations where trained personnel are not available or desirable for economic reasons, can eliminate these objections and costs. The complete maintenance of the engine is done on a fixed-fee basis for a designated period of time.

The exhaust gases of spark ignition and compression ignition (diesel) engines contain pollutants that for many engine applications are increasingly the subject of legislation restricting the quantity of pollutants the engine can emit. Examples of pollutants are carbon monoxide (CO), oxides of nitrogen (NO<sub>x</sub>), unburned hydrocarbons (HC), and, for diesels, particulates in the form of carbon soot. Pollutants can be measured on a specific basis, such as g/bhp-hr and ppm (parts per millions by volume), or on a site basis, such as lb/hr or tons/year. Engine manufacturers are designing “clean” engines that incorporate features to minimize the formation of pollutants during combustion and may include catalytic converters and particulate fibers in the exhaust system to further reduce the pollutants emitted in the exhaust gases.

The remaining conditions listed previously will be discussed in detail later.

## FUEL SYSTEMS

**Gasoline** Gasoline is used primarily with standby pumping units. Inasmuch as the spark ignition system first introduced the internal combustion engine to power applications, gasoline was used as the primary fuel. Commercial gasoline has an average heating value of 19,000 Btu/lb (44.2 MJ/kg). It is easy to transport and handle and, unlike gaseous fuels, does not require pressure storage and regulating equipment. The starting capabilities of a gasoline engine are satisfactory, provided the engine is in good operating condition. With the high-power engine of today, refinery control can produce a fuel matched to the operating conditions.

Gasoline does have some disadvantages that are reducing its use as an engine fuel. In small-volume usage, it is safe and easily handled. In larger volumes, it becomes expensive and hazardous. Because it is not entirely stable, it will deteriorate when exposed to gums and resins in storage over a period of time. There is also the possibility of condensation of water in the fuel, which is detrimental to good operation. The danger of fire is always present because of leaks in the system. Finally, the increased production and distribution of gasoline have made it a target of increasing taxation, making it economically prohibitive in many installations.

**Gas** A gaseous fuel system using natural gas, LPG, or sewage gas may be a simple manually controlled system, such as a gasoline engine, or a carefully engineered automatic system. The basic gas carburetion system consists of a carburetor and pressure regulator mounted on the engine. A gas distribution system, like a water supply system, must be at some designated pressure and flow, and so a field pressure regulator is required. The characteristics of this regulator will depend upon the gas analysis, the displacement of the engine, the speed range, and local regulations. A typical schematic of a gas fuel system is shown in Figure 3. The location of the regulator is generally under the jurisdiction of the gas utility that supplies it. In most cases, a single field regulator is all that is required, but at times this can cause problems. For example, subsequent installation of gas-burning equipment used intermittently may cause gas pressure regulation not compatible with the small amount required for pilot lighting. A single regulator installed some distance from the engine could result in hard starting because the engine vacuum is not sufficient for a full gas flow. To eliminate this problem, the initial regulator is set at a higher pressure in order to give a readily available supply of fuel for all devices.

Natural gas has an average heating value of 800 to 1000 Btu/ft<sup>3</sup> (29.8 to 37.3 MJ/m<sup>3</sup>). Commercial butane has a value of 2950 Btu/ft<sup>3</sup> (110 MJ/m<sup>3</sup>), and propane a value of 3370 Btu/ft<sup>3</sup> (126 MJ/m<sup>3</sup>). Commercial LPG fuel, which is a mixture of butane and propane, varies in both amount and corresponding heating value.

LPG fuel is produced by mechanical and compression processes, and the methods of distribution and handling must meet regulations. Natural gas is usually supplied under moderate pressures, seldom exceeding 50 lb/in (345 kpa), whereas LPG fuel is supplied as

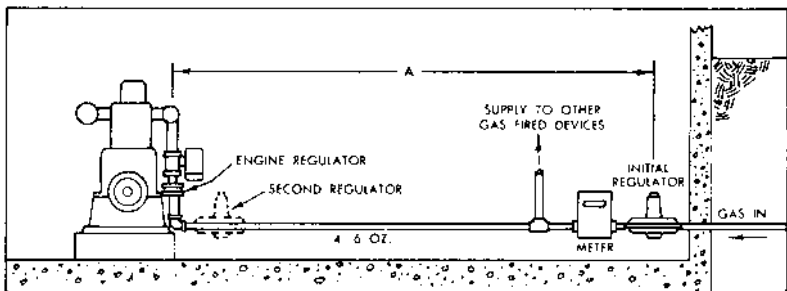


FIGURE 3 Typical natural gas fuel system (Waukesha Motor)

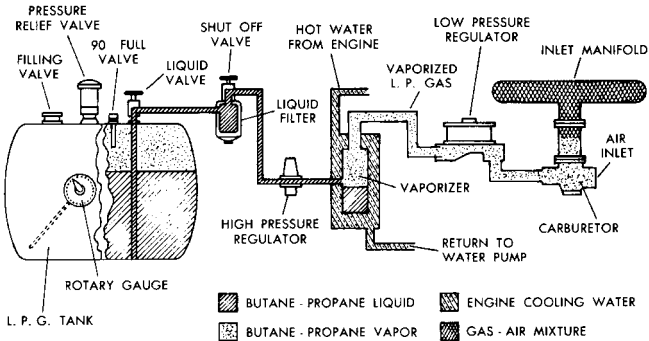


FIGURE 4 Typical LPG fuel system (Waukesha Motor)

a liquid under pressures as high as  $200 \text{ lb/in}^2$  ( $1380 \text{ kPa}$ ) in warm weather. As a result, natural gas will readily mix with air and burn, whereas LPG fuel must be changed from a liquid to a vapor with the addition of heat, as shown in Figure 4.

As a natural process in the modern waste-treatment plant, sewage gas may be produced in the sewage digester. This gas has the same basic qualities as natural gas and is composed of about 65 to 70% methane. It has a heating value of 550 to 700 Btu/ft<sup>3</sup> ( $20.5$  to  $26.1 \text{ MJ/m}^3$ ). The same basic carburetion system used for natural gas is used. Sewage gas contains inert substances, particularly hydrogen sulfide or free sulfur, which in the presence of free moisture or moisture resulting from combustion will form sulfurous acid, which is corrosive and thus damaging to the valves, pistons, and cylinder walls of an engine. An engine can tolerate from 10 to 30 g of sulfur per 100 ft<sup>3</sup> ( $350$  to  $1100 \text{ g per } 100 \text{ m}^3$ ). Beyond this, a filtering system to remove the sulfur and moisture is advisable.

**Diesel** The diesel engine over the years has been used for larger power systems. The initial cost of the system is justified to an extent by lower cost of the fuel. The better fuel economy of the diesel engine and its torque characteristics also are important factors in the selection of this fuel for many applications. Diesel fuel has one distinct advantage: it does not form the dangerous fuel vapors that other fuels do. It does require, however, a good fuel-filtering system because of contaminants in the fuel that can create problems for the precision design of the fuel-injection system.

Commercial diesel fuels are the residue that remains after the more volatile fractions of crude oil have been removed. The heating value is generally about 19,000 Btu/lb ( $44 \text{ MJ/kg}$ ). In the diesel engine, the fuel is injected into the cylinder at the end of the compression stroke in an atomized form. The compression stroke results in a temperature sufficient to ignite the fuel without the use of any ignition device. Although fuel systems from different engine manufacturers vary, the basic components are the same.

The larger diesel engines may be designed to operate on a dual fuel system. The engine operates on five gaseous fuels with a pilot injection of diesel fuel for ignition. In case of a loss of the gaseous fuel supply, the engine will convert to 100% diesel fuel.

**Relative Performance Curves** Typical performance curves comparing power, torque, and part-load fuel economy are shown in Figure 5.

## COOLING SYSTEMS

Cooling is essential in all internal combustion engines because only a small portion of the total heat energy of any fuel is converted to useful energy. The remainder is dissipated into

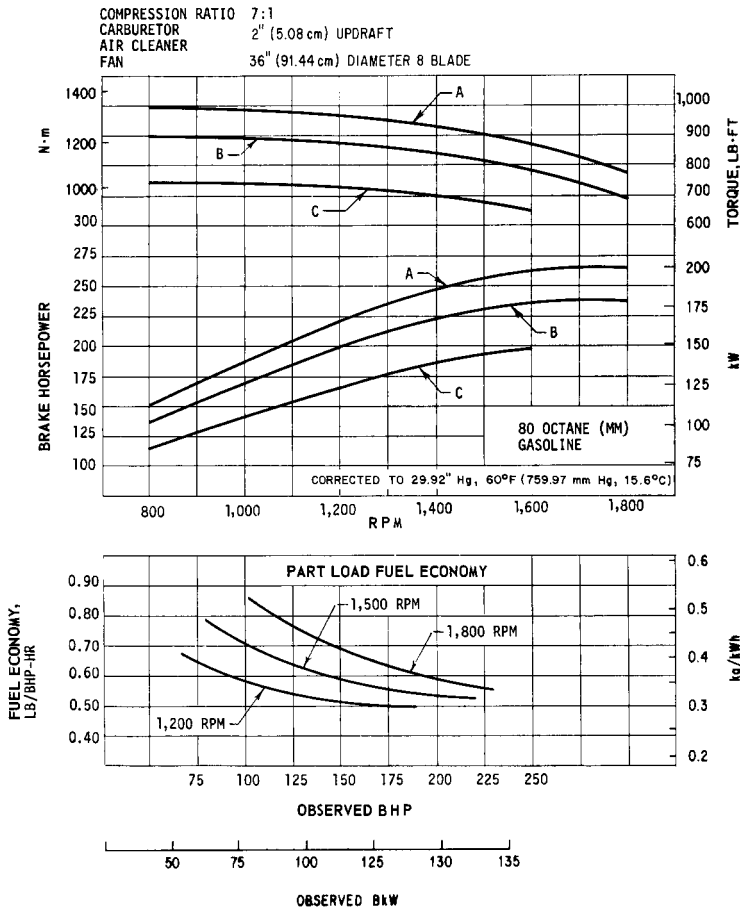


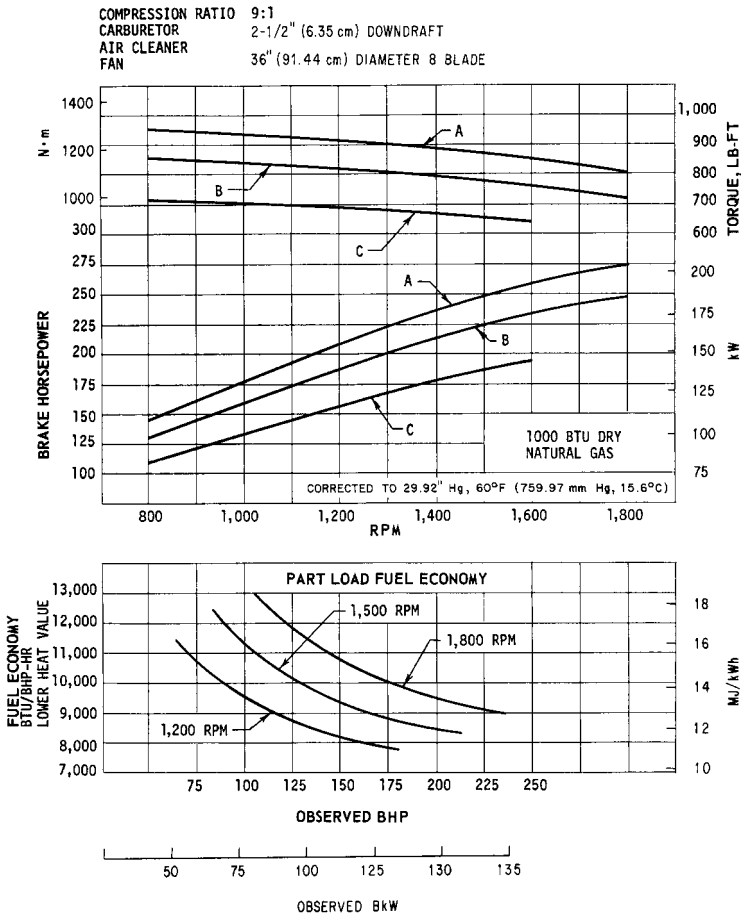
FIGURE 5A Gasoline engine performance curves: (A) maximum, (B) intermittent, (C) continuous ratings of engines with accessories (Waukesha Motor)

the coolant, exhaust, and lubricating oil and by radiation. A hypothetical heat balance is shown in Figure 6.

Specific data and recommendations on cooling requirements vary from one manufacturer to another. In general, the heat rejection to an engine cooling system will range between 30 to 60 Btu/hp · min (25 to 51 MJ/kWh) for diesel engines and up to 70 Btu/hp · min (59 MJ/kWh) for natural gas and gasoline engines. This heat must be transferred to some form of heat-exchange medium.

In designing any cooling system, certain factors must be considered:

- Additional heat from driven equipment, such as the cooling of speed-reducing or -increasing gears where the engine coolant is the medium
- Water-cooled exhaust manifolds on the engines or water-cooled exhaust turbochargers or after-coolers
- High ambient temperatures or heat from nearby equipment

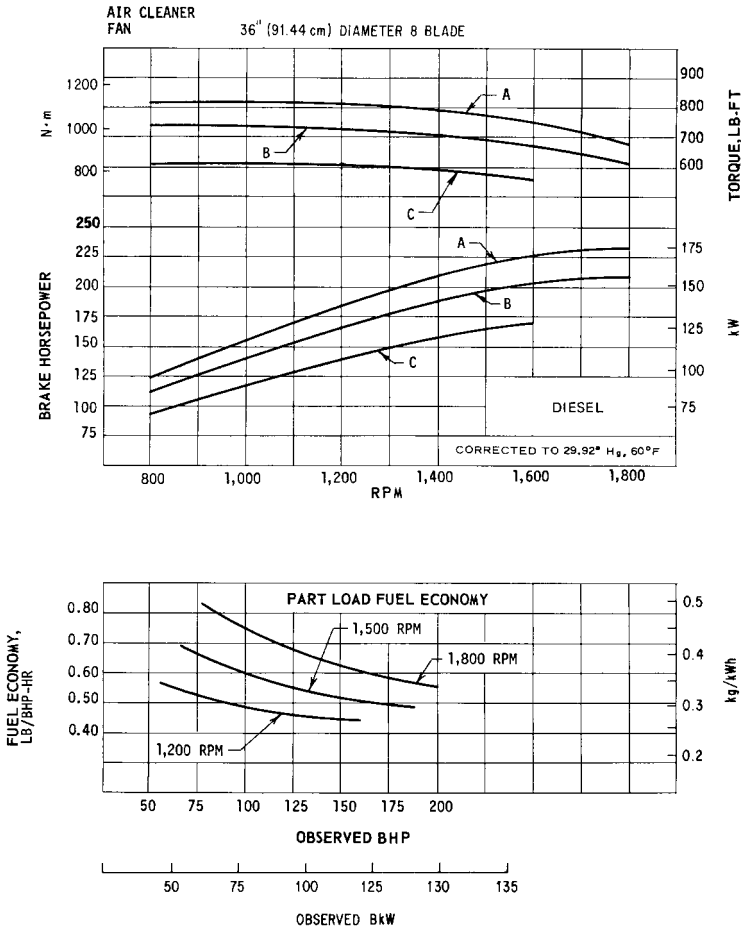


**FIGURE 5B** Gas engine performance curves: (A) maximum, (B) intermittent, (C) continuous ratings of engines with accessories (Waukesha Motor)

- Variation in the heat-exchanger coolant temperature
- Entrapment of substantial quantities of air in the coolant water
- Inability to maintain a clean cooling system

With any cooling system, one of the most important factors of design is the temperature drop across the engine. Most engine manufacturers desire a temperature differential of no more than 10 to 12°F (5.6 to 6.7°C), and closer values are desirable. A jacket-water temperature across the engine of 170°F (77°C) is preferred, and in high-temperature or waste-heat-recovery systems, temperatures of 200°F (93°C) or more are common and not harmful.

**Radiator** The radiator cooling system is perhaps the most common and best understood method of cooling. It is based on a closed system of tubes through which the jacket water passes. The heat is dissipated by a fan, creating a stream of moving air passing through



**FIGURE 5C** Diesel engine performance curves: (A) maximum, (B) intermittent, (C) continuous ratings of engines with accessories (Waukesha Motor)

the tubes. The fan is driven either by the engine or by an auxiliary source of power (Figure 7).

An engine in a fixed outside installation can be cooled without much difficulty. Certain factors must be considered, such as ambient temperature, direction of the prevailing wind, and presence of foreign airborne materials. In high temperatures (usually above 110°F [48°C]), a larger radiator is required. If the prevailing winds are extremely high, the unit can be located to offset normal fan flow. Screening can be used to prevent the clogging of the air passes in the radiator where the atmosphere tends to contain foreign airborne material, such as dust.

Radiator cooling may be used in an inside installation, but there are certain problems which, unless properly anticipated, limit this system. The recirculation of cooling air and the radiation of exhaust heat from the engine create a problem. As was previously pointed out, every 10°F (5.6°C) rise above 60°F (15.6°C) results in a 1% loss in power. When 5 to 10% of the total heat put into an engine is radiated, some means of power ventilation must



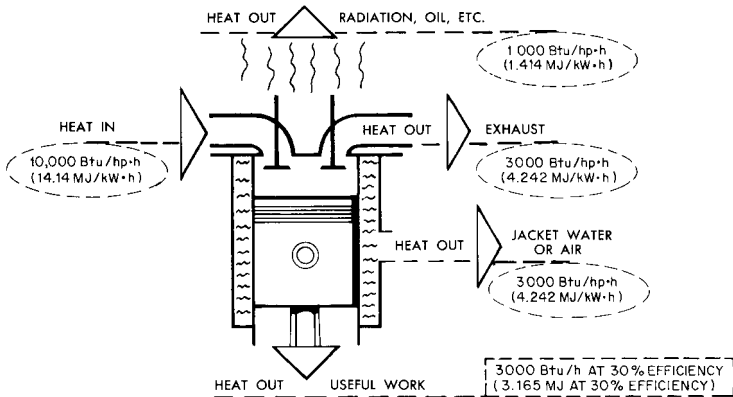


FIGURE 6 Hypothetical heat balance (Waukesha Motor)

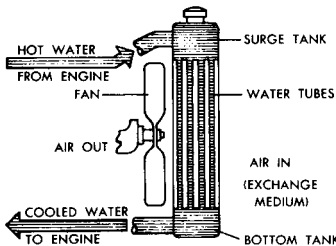


FIGURE 7 Radiator cooling system (Waukesha Motor)

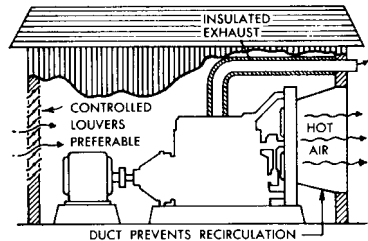


FIGURE 8 Radiator cooling system for an inside installation (Waukesha Motor)

be provided to remove this heat through ducts, louvers, or forced ventilation with a separate fan. An installation of this type is illustrated in Figure 8.

**Heat Exchanger** The heat exchanger cooling system (Figure 9) is the best system for a stationary engine installation. Using a tube bundle in a closed shell, the cooling exchange medium is water (often called raw water). This water may be plant or process water; it may be recirculated or, in standby installations, allowed to pass to waste. The system has the advantage of the radiator cooling system in that it is self-contained: the quantity and quality of the water in the engine can be controlled. It has the further advantage of not being affected by the flow of heat to air movement if the heat of radiation is taken into account in the design of the system. On the other hand, the cooling medium, unless used in a plant system, is a disadvantage because it is costly. A separate pump is required to provide the necessary water for cooling unless city water or process water is under sufficient pressure.

**City Water and Standpipe** City water cooling is designed to take water directly from the city main or from the pump the engine is driving. It is used on some emergency or standby installation. It is simple and inexpensive, gives unlimited cooling for moderate-size engines, is easily understood, and will operate instantly in an emergency. On the negative side, the cooling water is wasted, corrosive elements may be introduced into the engine jacket water system, and it may create excessive temperature changes across the engine jacket.

Standpipe cooling (Figure 10) is basically the same as city water cooling except that a thermostatic valve is employed to admit makeup water as required. The vertical pipe is a

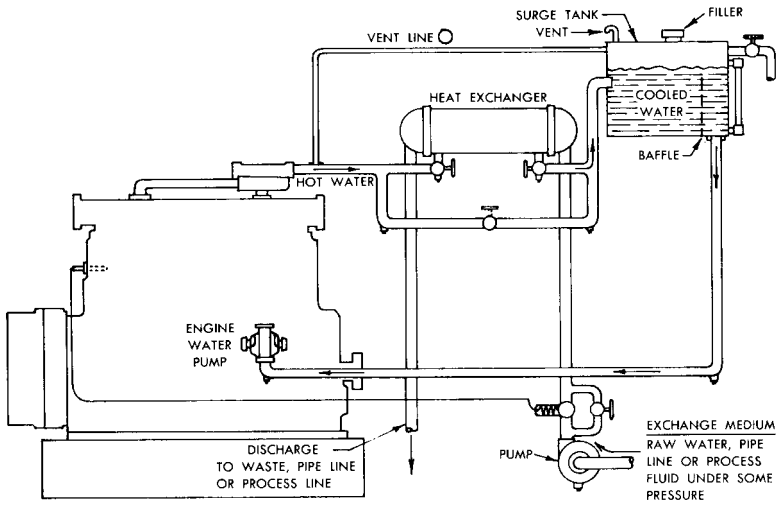


FIGURE 9 Heat exchanger cooling system (Waukesha Motor)

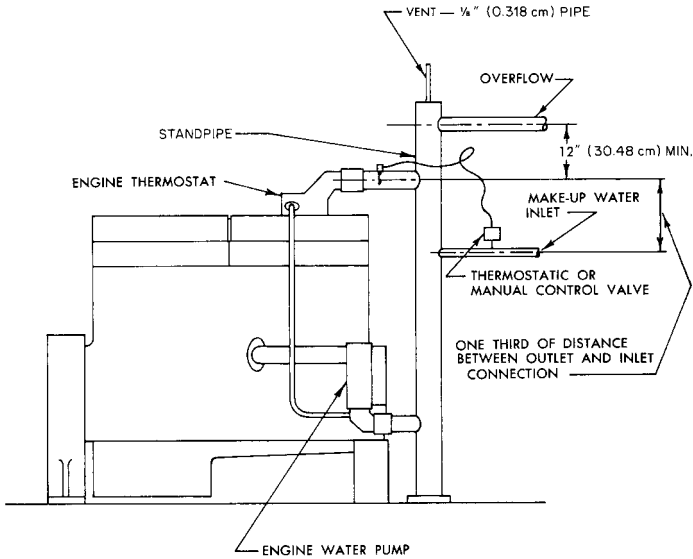


FIGURE 10 Standpipe cooling system (Waukesha Motor)

blending tank into which city water is introduced only in the amount necessary for makeup. The standpipe system is inexpensive and simple to operate.

**Ebullition** In installations where heat is required for process equipment, a method of high-temperature, or ebullition, cooling is being used as a very economical method, particularly with larger installations. This system has been termed *steam cooling, high-temperature, or Vapor-phase* (a registered trademark). In this system, the coolant leaves

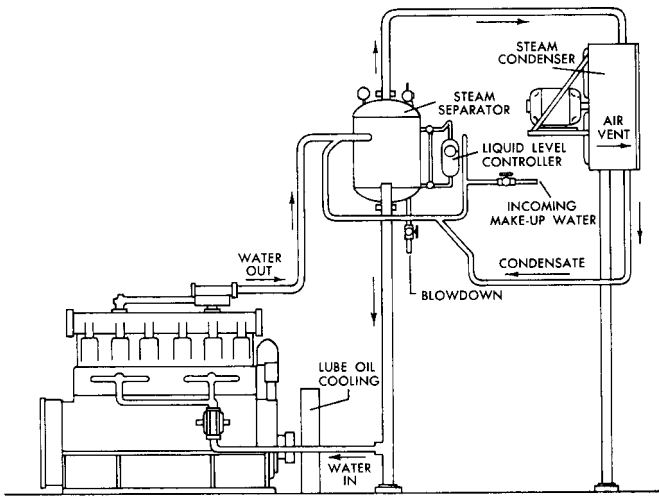


FIGURE 11 High-temperature cooling system (Waukesha Motor)

the engine at a temperature equal to or above its atmospheric boiling point and under sufficient pressure to remain liquid until discharged from the engine into a flash chamber, where a drop in pressure causes the formation of steam, which is condensed and returned to the engine at very near the discharge temperature. A schematic of this system is shown in Figure 11. This system has the advantages of a very small temperature differential across the engine, which minimizes distortion of all working parts, and a constant working temperature regardless of load. Because of the higher working temperatures, the combustion area and crankcase of the engine have fewer liquid by-products of combustion and corrosive materials. Of prime importance is the waste heat that can be recovered for plant process with a very small amount of makeup water for cooling.

**Cooling Tower** Cooling towers are used in some large or multiple-engine installations. Through the use of a current of air, produced either by a natural draft or by mechanical means, a tower causes a sensible heat flow from the cooling water to the air. Atmospheric, or natural, draft towers depend upon natural wind velocities and thus can vary widely. Mechanical draft towers, where the air supply can be controlled, can be put in any area, but the limit to their cooling capacity is the power required to operate them. As the water volume increases, the volume of air required and the pressure the fan has to operate against increase. A point is reached where the cost of installation and operation becomes prohibitive. A diagram of a system that combines components of the cooling systems mentioned plus the waste-heat recovery system silencer, to be mentioned later, is shown in Figure 12.

## AIR-INTAKE SYSTEMS

A most important consideration in the application of an engine to any pump drive is the engine's ability to "breathe." As air is required for combustion, the design engineers of any project must take into account the necessary provisions for this air. The environment, the service, the speed range of the engine, the duty cycle, and the location from which the combustion air is to be taken are of vital importance.

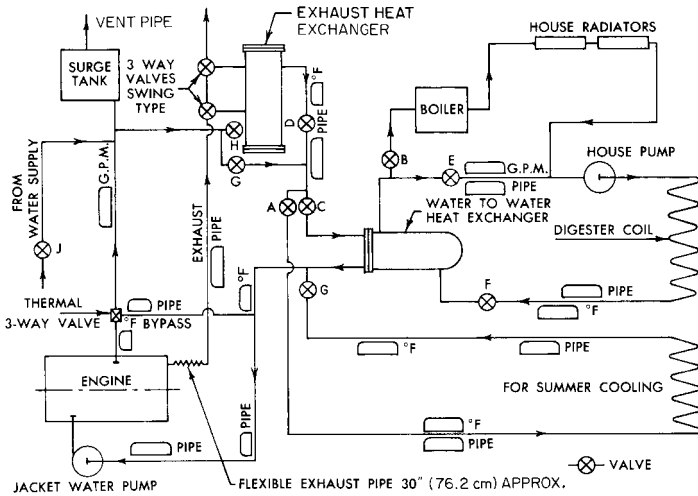


FIGURE 12 Complete cooling system, including waste-heat recovery (Waukesha Motor)

The first step in the selection of any intake system is to determine the volume of air, in cubic feet per minute (cubic meters per second) required for combustion, which may be calculated by the formula:

$$V_{\text{ideal}} = \frac{B^2 \times S \times \text{rpm} \times N}{C \times K}$$

where  $B$  = cylinder bore, in (cm)

$S$  = piston stroke, in (cm)

rpm = engine speed, revs/minute

$N$  = number of cylinders

$C$  = 2,200 for  $V_{\text{ideal}}$  in CFM or  $76.39 \times 10^6$  for  $V_{\text{ideal}}$  in  $\text{m}^3/\text{s}$

$K$  = 1 for two-stroke cycle and 2 for four-stroke cycle

Volumetric efficiency, defined as the ratio of actual air flow to ideal air flow, will vary with engine design, but an average of 80% may be used to determine the air cleaner size. Two-stroke cycle engines will require approximately 140% air flow calculated by the above equation. For supercharged and turbocharged engines, the air flow requirements should be obtained from the manufacturer.

The two basic cleaners available are wet and dry. The wet, or oil-bath, cleaner consists of either an oil wire mesh or an oil bath through which the air must pass. A dry cleaner uses a paper or cloth filter that traps dust, lint, and so on but allows the air to pass through.

The installation of a suitable air cleaner is important. In cases where adequate air can be supplied through proper ventilation of the area surrounding the engine, it is best to mount the cleaner on the engine. If it is necessary to bring air to the engine from outside the area of the building, certain design factors must be considered. The pipe connections from an outside cleaner should be tight and mechanically strong, and fabric hose should not be used unless the length is relatively short. The air to the engine should not be heated by close proximity to the engine or any other heating device because, as previously mentioned, power loss occurs with air temperatures above 60°F (15.6°C). To avoid restrictions

in the system, there should be no sharp bends in the piping. Finally, any outside air cleaner must be designed so moisture such as rain or snow cannot enter the system.

The air cleaner system on a turbocharged engine must be able to remove any impurities in the air that would be detrimental to the efficiency of the turbocharger. Because of the increased air requirements, a larger air-cleaner system must be used on such units.

## **EXHAUST SYSTEMS**

---

An engine consumes a large volume of air for combustion, and that volume must be removed after combustion. It is necessary that the exhaust back pressure be kept at a minimum while this volume is being removed. The exhaust piping should be properly sized, and long sweep elbows should be employed if necessary. Unless the back pressure is kept low, the following conditions can result:

- Loss of power
- Poor fuel economy
- High combustion temperatures with increased maintenance
- High jacket water temperatures
- Crankcase sludging with resulting corrosion and bearing wear

All internal combustion engines create noise. Depending upon the location of the engine, this noise can be a problem. Normally, when measured from a distance of about 10 ft (3 m), an unmuffled engine creates a decibel noise level ranging from 100 for the small- and medium-size engine to 125 for the larger engine. Thus most engine installations incorporate some form of exhaust silencer, or muffler. Depending upon the degree of silencing, a muffler will reduce the unmuffled decibel reading by 30 to 35 dB. Various types are manufactured to meet the required conditions and are classified as follows:

- Standard or industrial
- Semiresidential (high-degree)
- Residential or hospital (supercritical)

The basic exhaust silencer is designed as either a dry type or wet type. The latter is used in installations such as sewage or water treatment plants, where the recovery of heat for plant processes is important. Basically this type may be classified as a low-pressure boiler. Water is admitted to the silencer through tubes or coils to pick up the heat from the exhaust. As shown in Figure 6, approximately 30% of the total heat input into the engine is exhausted. The wet-type silencer is designed to regain about 60 to 70% of this heat. This silencer has an advantage in its ability to operate either wet or dry. Thus when heat is not required, it may be operated dry and vice versa.

## **STARTING SYSTEMS**

---

Starting methods for engines fall into two broad categories: direct and auxiliary.

**Direct** The direct system, used primarily with large engines, employs some means of exerting a rotating force on the crankshaft, such as the introduction of high-pressure air directly into the cylinders of the engine. A direct system on small air- or water-cooled engines using either a rope or a hand crank has to a large extent been discarded in favor of an auxiliary method.

**Auxiliary** The auxiliary system employs a small gear that meshes with a larger gear (ring gear) on the engine flywheel. The ratio of the number of gear teeth on the large gear

to those on the small gear is called the *cranking ratio*. Generally, the larger the ratio, the better the cranking performance. The auxiliary system uses several means to drive the small gear:

- Electric motor
- Air motor
- Hydraulic motor
- Auxiliary engine

**ELECTRIC MOTOR** The electric motor may be either dc or ac. The dc motor most commonly used is available in 6, 12, 24, or 32 V. The voltage size will depend upon the size of the engine, the ambient temperature, and the desired cranking speed of the engine. The dc system requires a source of outside power, usually in the form of a storage battery. To assure prompt starting, a charging system for the battery is required in the form of either a charging generator driven by the engine or an ac-powered battery trickle charger. The latter is recommended for standby installations where an engine-driven charging generator functions only when the engine is operating. During idle periods, the battery will lose its charge unless maintained by a trickle charger. In recent years, there has been a trend toward the use of an ac generator, or alternator, which has the advantages of small size, higher voltage and amperage, competitive price, and good charging ability under idle speed conditions.

Another type of electric motor is a line voltage starter available in 110, 220, or 440V ac. It has the advantages of faster and more powerful cranking, the elimination of the battery and charging system, less maintenance, and sustained cranking through unlimited available electric power. Its disadvantages are a higher initial cost, the requirement of high line voltage at the site, the danger to personnel due to the high voltage, and the requirement to conform to existing wiring and installation codes.

**AIR MOTOR** The air motor, which is usually of the rotary-vane type, uses high-pressure air in the range of 50 to 150 lb/in<sup>2</sup> (340 to 1030 kPa) to turn it in starting the engine. It is mounted on the engine flywheel housing to mesh with the gear on the flywheel in the same manner as the electric motor. An outside source of air from an air compressor, usually with a 250-lb/in<sup>2</sup> (1720-kPa) capacity, is required. A pressure-reducing valve is installed in the line to the engine. The high-pressure air stored in an adequate receiver is sufficient for several starting cycles. This starting system has the advantages of faster cranking, sustained cranking as long as the air supply lasts, suitability in hazardous locations where an electric system might be dangerous, and ability to operate on either compressed air or high-pressure natural gas. Its disadvantages include a higher initial cost, the requirement of an air-compressor system, and, finally, a shutdown condition if the air supply is depleted before the engine starts.

**HYDRAULIC MOTOR** The hydraulic motor system consists of the motor, an oil reservoir, an accumulator, and some means of charging the accumulator. The accumulator, which is a simple cylinder with a piston, is charged on one side with nitrogen gas. As the hydraulic fluid, usually oil, is pumped into the other side, the gas is compressed to a very high pressure. When released, the fluid turns the motor, which in turn rotates the engine. The system can be charged by hand, with an engine-driven pump, or with an electric motor-driven pump. Generally, an engine-driven or electric-motor-driven pump is used in conjunction with the hand pump in case of an engine or electrical failure. This system has the same basic advantages of the air motor except that there is no prolonged starting. If the engine is in good operating condition, the cranking is fast and a start is instantaneous, but, if not, it is necessary to recharge the system before another start can be made.

**AUXILIARY ENGINE** A small auxiliary air-cooled or water-cooled engine is sometimes employed for starting. It may be mounted on the engine in the same manner as the other systems, or a belt drive may be employed. Some form of speed reduction is required to reduce the higher speed of the auxiliary engine to that required for proper cranking. The

principal advantage of such a system is a complete independence from outside sources of power, such as batteries, air, or pumps, but this is offset by a higher initial cost and the required regular maintenance of the engine.

## IGNITION SYSTEMS

---

The internal combustion engine requires some means of igniting the combustible charge in the cylinder at the proper time. Today's high-compression gasoline and gas engines demand a system that will produce a high-tension spark across a short gap in the combustion chamber for the ignition of the charge. It is obvious that the design of the combustion chamber must be such that this combustible mixture of fuel and air is present between the discharge gap when the spark occurs; otherwise, ignition will not take place.

Ignition systems for gasoline or gas engines are considered high or low tension. The energy system for the high-tension system is either an electric generator and battery or a magneto. The generator and battery produce a direct current at 6 to 12 V potential, and the magneto produces an alternating current with higher peak voltages. With either energy source, this system has a primary circuit for the low-voltage current and a secondary circuit for the high-voltage current.

The primary circuit consists of the battery, an ammeter, an ignition switch, a primary coil, and breaker points and a condenser in the distributor. When the ignition switch and the breaker points close, a current flows through the circuit and builds up a magnetic field in the primary coil. Opening the breaker points breaks this circuit, causing the magnetic field to start collapsing. As the field collapses, it produces a current that flows in the same direction in the primary circuit and charges the condenser plates. The condenser builds up a potential opposing flow, which discharges back through the current. This results in a sudden collapse of the remaining magnetic field and the induction of a high voltage into the secondary winding of the coil. The breaker points are opened and closed by a cam which is engine-driven, usually at half engine speed.

The secondary circuit consists of the secondary coil winding, the lead to the distributor rotor, the distributor, the spark plug leads or wires, and the spark plug. A magneto eliminates the battery, but includes in its construction the balance of both primary and secondary circuits. It may have either a rotating coil and stationary permanent magnets or a stationary coil and rotating magnets. The relative movement of the primary coil winding and the magnets induces an alternating current in the primary circuit, the breaking of which induces a high-voltage current in the secondary circuit.

The development of the modern engine has required many refinements in spark plug design, but basically a spark plug consists of two electrodes, one grounded through the shell of the plug and the other insulated with porcelain or mica. The insulated electrode is exposed to the combustion. The heat flow occurs from this electrode to the spark plug shell through the grounded electrode.

Recent developments in ignition systems have produced the low-tension and breakerless systems. The breakerless system has eliminated most of the moving parts in the distributor system. The breaker points in the distributor system are actually a switch that opens and closes the primary circuit of an ignition coil. In the breakerless system, the use of solid-state devices provides a switch with no moving parts to wear or require adjustment.

The low-tension magneto system has been developed to reduce electrical stresses in the ignition circuit. The secondary coil has been removed from the magneto proper and relocated near each spark plug. The low voltage generated by the magneto is transmitted through the wiring harness to secondary coils, which then step up to the voltage to be transmitted through short leads to the spark plug. These leads may be insulated to withstand the stresses imposed upon them. This results in a minimum of electrical stresses with a resulting longer life of all components of the system.

As was mentioned previously under fuel systems, the diesel engine used the heat of compression for ignition; thus no auxiliary systems, such as the systems mentioned above, are required. The fuel is injected into the combustion chamber under relatively high pressure through the use of a fuel pump and injection nozzle. This system may be either an

individual pump and nozzle for each cylinder, commonly called a *unit injection*, or a multicylinder pump that maintains a high pressure in a common fuel line connected to each injection nozzle. The latter is normally called the *common rail system*.

## ENGINE INSTALLATIONS

**Foundation** The correct foundation, mounting, vibration isolation, and alignment are most important to the success of any engine installation. All stationary engines require a foundation or mounting base. There are many variations, but all basically serve to isolate the engine from the surrounding structures and absorb or inhibit vibrations. Such a base also provides a permanent and accurate surface upon which the engine and usually the pump may be mounted.

To meet these requirements, the foundation must be suitable in size and mass, rest on an adequate bearing surface, provide an accurately finished mounting surface, and be equipped with the necessary anchor bolts.

The size and mass of the foundation will depend upon the dimensions and weight of the engine and the pump (if a common base is considered). The following minimum standards should be followed:

1. Width should exceed the equipment width and length by a minimum of 1 ft (0.3 m).
2. The depth should be sufficient to provide a weight equal to 1.3 to 1.5 times the weight of the equipment. This depth may be determined by the following formula:

$$\text{In USCS units} \quad H = \frac{(1.3 - 1.5)W}{L \times B \times 135}$$

$$\text{In SI units} \quad H = \frac{(1.3 - 1.5)W}{L \times B \times 2162}$$

where  $H$  = depth of foundation, ft (m)

$W$  = weight (mass) of equipment, lb (kg)

$L$  = length of foundation, ft (m)

$B$  = width of foundation, ft (m)

135 = density of concrete, lb/ft<sup>3</sup> (2162 kg/m<sup>3</sup>)

The soil-bearing load in pounds per square foot (kilograms per square meter) should not exceed the building standard codes. It may be calculated by the formula

$$\text{Bearing load} = \frac{(2.3 - 2.5)W}{B \times L}$$

Foundation or anchor bolts used to hold the equipment in place should be of SAE grade No. 5 bolt material or equivalent. The diameter, of course, is determined by the mounting holes of the equipment. The length should be equivalent to a minimum embedded length of 30 times the diameter plus the necessary length for either a J or an L hook. An additional 5 to 6 in (13 to 15 cm) should be provided above the top surface of the foundation for grout, sole plate, chocks, shims, equipment base washers, and nuts, plus small variations in the surface level. Around the bolts, it is a good practice to place a sleeve of iron pipe or plastic tubing to allow some bending of the bolts to conform with the mounting hole locations. This sleeve should be about two-thirds the length of the bolt, with its top slightly above the top surface of the foundation to prevent concrete from spilling into the sleeve.

Sole plates running the length of the equipment are recommended for mounting directly to the foundation. Made of at least  $\frac{3}{4}$ -in (19-mm) hot- or cold-rolled steel and a



width equivalent to the base-foot mounting of the equipment, they will provide a level means of mounting and will avoid variations in the level of the concrete. These plates should be drilled for the mounting holes and drilled and tapped for leveling screws, which will permit the plates to be leveled and held during the pouring of grout.

**Alignment** Although the alignment will vary with the type of engine and the pumping equipment, the basic objective remains the same. The driven shaft should be concentric with the driver shaft, and the centerlines of the two shafts should be parallel to each other. Rough alignment should be made through the use of chocks and shims. A dial indicator should be used to check deflection by loosening or tightening the anchor bolt nuts until there is less than a 0.005-in (0.13 mm) reading at each bolt. Shims should be added or removed to arrive at this point. A final check should be made with all the conditions "hot," as the engine and its driven equipment expand at the rate of  $0.000006 \text{ in}/^\circ\text{F}$  ( $0.27 \mu\text{m}/^\circ\text{C}$ ) above ambient hot to cold. Although the coupling, or driving member between the engine and the pump is not discussed in this section, it must be considered in the final alignment.

**Vibration Isolation** It is desirable to isolate the engine, and at times the pumping equipment, from the building structure because of vibrations. Cork (Figure 13) is used in the larger and heavier installations. A combination of cork and rubber pads may be used at each mounting hole on small- or medium-size installations, and spring isolators may be used on a complete installation if flexible hoses are used for fuel, water, and air connections where required. The manufacturer of the engine and the pumping equipment should be consulted in the use of any isolating material or device.

Vibrations are closely associated with the driving and driven equipment, couplings, and other connections. These linear vibrations may be caused by improper supports of the unbalanced parts, which produce a *torsional* vibration. An understanding of this vibration is important because its elimination is the responsibility of the engine and the driven-equipment manufacturer. It is complex and cannot be detected without the use of calculations and special instruments.

The basic concept involves an elastic element, such as an engine crankshaft, which tends to twist when any firing impulses are applied. When these forces are removed, the elastic body will try to return to its original position. The driven mass and the connecting elements tend to resist these external impulses. The natural elasticity of the crankshaft and its connecting system allows a small amount of torsional deflection and tends to

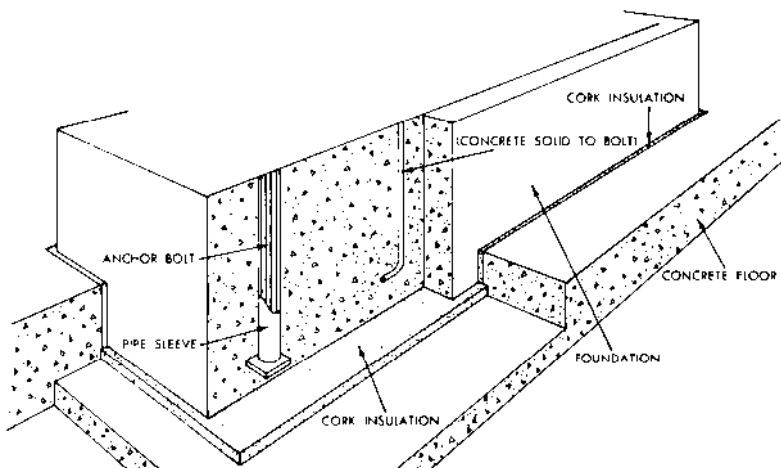


FIGURE 13 Engine foundation installation (Waukesha Motor)

reduce the deflection as the external impulses reduce in force. Other reciprocating forces in the engine and external forces in the driven equipment may excite vibrations in the entire system. When all these forces come into resonance with the natural frequency of the entire system, torsional vibration will occur. This vibration may or may not be serious but, being complex, cannot be solved hastily.

The engine and pump manufacturer designs and constructs the product so critical harmonic vibrations will not be present under normal speeds and loads. However, there is no way to control the combination. An analysis of the complete system should be made. This requires a study of the mass elastic system of the combination, involving the mass weight and radius of gyration of all rotating parts. This study should be made either by the engine or pump manufacturer or by a torsional-analysis specialist.

#### **FURTHER READING**

---

Gunther, F. J. "Gas Engine Power for Water and Wastewater Facilities." *Water & Sewerage Works*, **112** and **113** (November 1965 to July 1966).

# 6.1.4 HYDRAULIC TURBINES

WARREN G. WHIPPEN  
HOWARD A. MAYO, JR.  
DONALD R. WEBB

## **PUMPING APPLICATIONS**

---

In many pumping applications, the liquid remains at a high pressure after it has completed its cycle. It is often economically desirable to recover some of the energy, which will otherwise have to be dissipated when the liquid is brought back to a lower pressure. Instead of running the liquid through a pressure-reducing valve to destroy the energy, a hydraulic turbine may be installed. This turbine can therefore assist in driving the process pumps. There are many such applications in use. Among these are the use of turbine-driven pumps in gas-cleaning operations. Here the solutions from scrubber towers are passed through turbines that in turn drive pumps. Some of the solutions involved in such a process are water saturated with carbon dioxide at a temperature of 40 to 70°F (4 to 21°C) and potassium carbonate containing dissolved carbon dioxide at a specific gravity of 1.31. A liquid at the much lower specific gravity of 0.84 has been used in power-recovery turbines in a glycol-ethylene hydration process.

One of the oldest applications of turbine-driven pumps was for fire-fighting equipment in mills having a natural head of water. The large volume of low head water was routed through a hydraulic turbine that drove the pump to pressurize a sprinkler system or provide high-pressure water to the fire-hose connections. Today, hydraulic turbines are used to drive pumps that generate fire-fighting foam.

At thermal power plants, cooling water returning from the cooling towers has been used to drive a hydraulic turbine directly connected to a pump that provides part of the cooling water. Naturally, in such an application, the power from the turbine alone is not enough to maintain the pumping system. Therefore an auxiliary power source is also required.

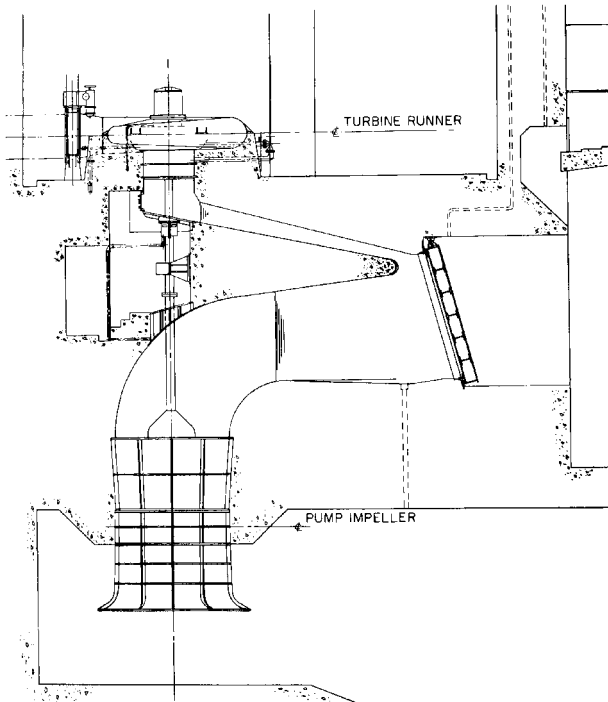
Turbines using oil pressure have been employed at thermal power plants. Large steam turbines obtain bearing oil and control oil pressure from a main feed pump that is directly connected to the steam turbine shaft. A small amount of the oil at this high pressure is used for the relay control, with the majority of the oil going to the bearings at a lower pressure. To reduce the oil pressure from that required by the relays to that needed by the

bearings, the oil is passed through a turbine driving a booster pump that pressurizes the oil at the intake of the main pump. At locations with high flood levels, it is preferable to locate pumps and electrical equipment above flood level. Some recent steam power plant installations have used the return from the condenser to the river (normally an appreciable drop in head) to drive a hydraulic turbine, which in turn may assist in driving the condensate pumps. Also, effluent from sewage treatment plants may have a significant discharge head.

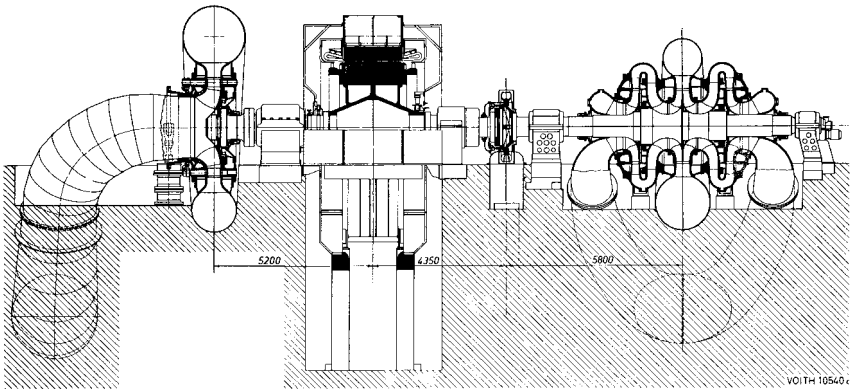
It is often economical to use a small volume of water at a high head to move a large volume of water at a low head. Of course, the reverse application can also be accomplished. The former procedure is employed at hydroelectric projects where it is necessary to operate fishways to enable migrating fish to continue traveling upstream over the dam. The large volume of water is used both to attract the fish to the fish flume and to transport the fish to the fish ladders. An example of such an installation can be seen in Figure 1.

Turbines have also been used to start large pumping units when the hydraulic conditions are suitable. The impulse turbine, which develops maximum torque at zero speed, is especially useful for this application. The power required on such a starting turbine would be less than the power required on a starting motor to do the same job. Many electric controls can be eliminated when starting with a turbine. An illustration of this application is shown in Figure 2.

Desalination plants have been built wherein salt is removed from seawater by pumping it through a membrane at high pressure. Only pure water goes through the membrane, with most of the sea water being used to carry away the salt. This excess high-pressure sea water is then put through a power-recovery turbine that helps to drive the high-pressure pumps.



**FIGURE 1** Turbine-driven fishway pumps. High head, low volume Francis-type turbine drives a low head, high-volume propeller pump at Rocky Reach, Washington.

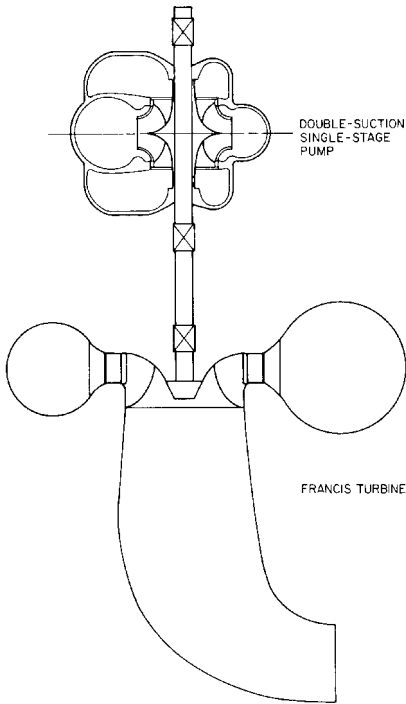


**FIGURE 2** Impulse runner used to start a large pump. Left to right: Francis turbine, generator motor, starting impulse turbine, and two-stage double-suction storage pump (Adapted from Voith Publication 1429, J. M. Voith GmbH, Heidenheim, Germany).

It is often desirable to have the turbine and pump running at different speeds, and this has been accomplished by means of a variable-speed coupling between turbine and pump. Reliable low-speed gear increasers or reducers of up to 35,000 hp (26,000 kW) are being built by many manufacturers. In applications such as starting a pump by means of a turbine, a mechanism may be needed to disengage the turbine after the pump has been started, in order to minimize windage and friction. Disengaging couplings may be hydraulic or mechanical and may be actuated when the unit is stationary or rotating, depending on the application. However, it is possible to allow the turbine to spin in air with the pump after the pump has been started. Figure 3 is an illustration of a turbine-drive pump arrangement.

## TYPES OF TURBINES

Three types of turbines will be discussed: propeller (fixed and adjustable blades), Francis, and impulse. Figures 4 to 7 are illustrations of these turbine runners. Figure 8 shows a complete Francis turbine unit. The fixed- and adjustable-blade propellers and runners are essentially the same, with the exception that the adjustable is suited to a much wider range of loading conditions. This versatility is reflected in a higher manufacturing cost for the adjustable blade. The Francis runner is much like a centrifugal pump impeller running backward. The impulse runner (or Pelton wheel) is for high-head applications. The water is first channeled through a nozzle that directs a jet of water into the bowl-shaped runner buckets. This jet then discharges into the atmosphere. When a high back pressure is present in the housing, the impulse wheel cannot discharge properly. The performance drops off rapidly as the back pressure is increased. However, it is sometimes possible to admit low air pressure into the impulse runner housing to lower the level of the liquid surface to below the level of the runner. When the high turbine back pressure cannot be eliminated, a Francis turbine will perform much better than an impulse turbine. Figure 9 illustrates the relative efficiencies of the different types of runners. The fixed-blade propeller and Francis runners operate most efficiently in a range near full load, and operating time should be limited at low loads. The impulse and adjustable-blade runners, however, are designed for high efficiencies over a large load range. The adjustable-blade propeller accomplishes this by changing the angle of its blades by means of linkage in the hub of the runner. With the impulse runner, the size of the jet is controlled by the nozzle needle, which enables the runner to maintain high efficiencies at low loads.



**FIGURE 3** Double-suction single-stage pump driven by a Francis turbine (Voith Siemens Hydro)



**FIGURE 4** Mixed flow propeller runner (Voith Siemens Hydro)

## **TURBINE ARRANGEMENTS**

As is typical with pumps, hydraulic turbines are usually arranged with their power shafts either vertical or horizontal. In recent years, several low head installations have had inclined shafts to reduce excavation costs. The large (above 10,000 hp or 7,000 kW) vertical propeller turbines with concrete water passages have not been used with pumps. This is also true with very large, high head Francis turbines with steel-lined spiral shaped water passages. Mid-size and small hydraulic turbines of all three types may have vertical or horizontal shafts and usually steel water passages when used with pumps. Horizontal shaft arrangements have the advantage of better access to each piece of equipment. They usually require a greater floor area but lower power/pump house. For low heads (under 30' or 10 meters), propeller turbine installations have used inclined shafts with Bulb and Pit generator housings. TUBE turbines with a nearly straight draft tube have also been arranged with inclined shafts. For very low heads (under 15' or 5 meters), water wheels extending the width of a spillway are being considered where conventional hydraulic turbines are too costly.

Each project or site is likely to have special conditions, which will influence selection of the optimum turbine and pump arrangement.

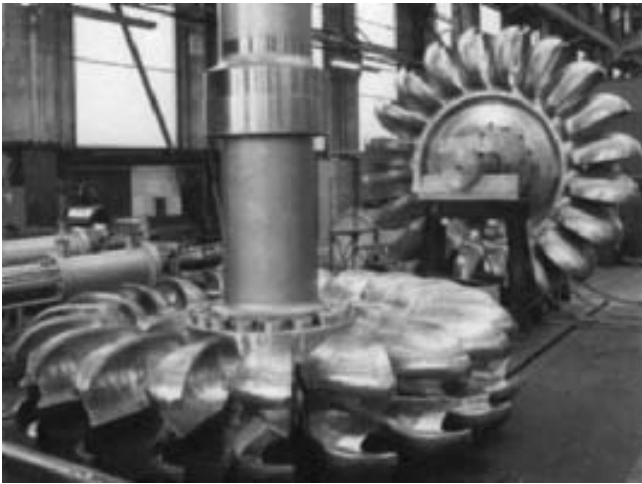
**Flow Units** The size of hydraulic turbines has become so large that the earlier conventional flow quantity of cubic feet/minute (cfm) is today cubic feet/second (cfs) or cubic meters per second (cms). The following conversions are therefore useful:



**FIGURE 5** Adjustable-blade propeller runner. “Kaplan” turbines have adjustable blades coordinated with adjustable wicket gates (Voith Siemens Hydro)



**FIGURE 6** Francis runner has shorter buckets than a centrifugal pump impeller (Voith Siemens Hydro)



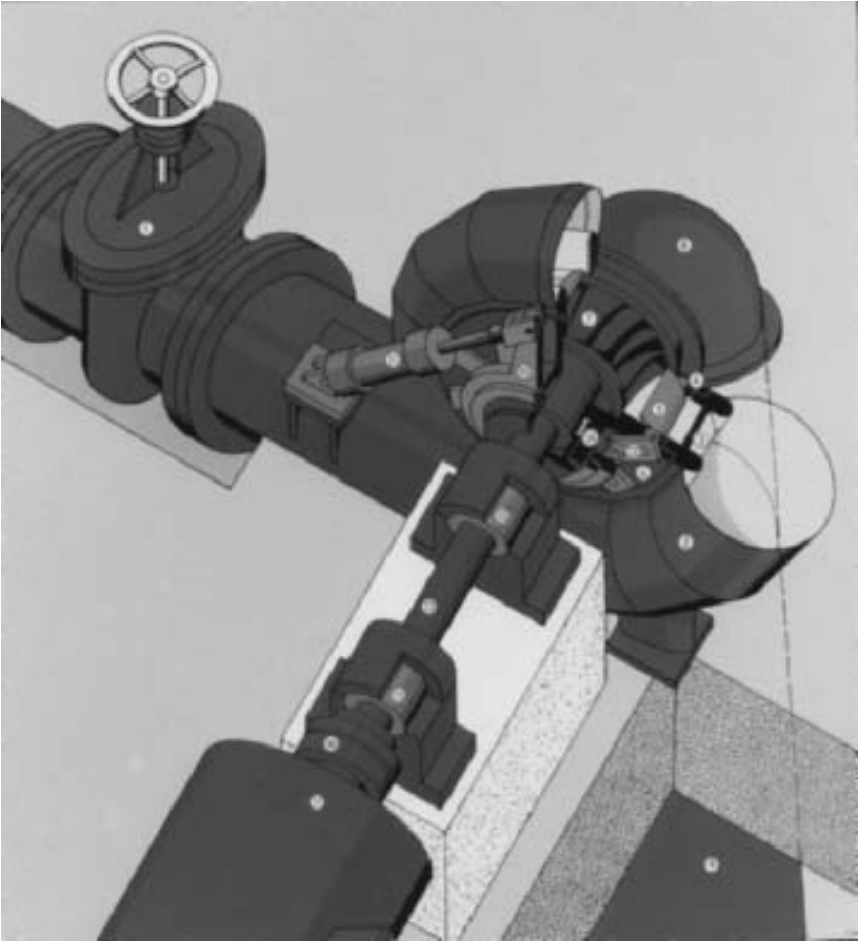
**FIGURE 7** Impulse (or Pelton) runners (Voith Siemens Hydro)

1 cfs = 449 gpm or 1.077 mgd

1 cubic foot = 7.48 US gallons

British imperial gallon = 1.2009 US gallon

1 cms = 35.3 cfs



**FIGURE 8** Complete standard Francis turbine unit with spiral case and elbow draft tube: 1) Shut-off valve, 2) Spiral case, 3) Stay ring, 4) Curb ring, 5) Guide vane, 6) Turbine cover, 7) Runner, 8) Draft tube elbow, 9) Draft tube, 10) Operating ring, 11) Servomotor, 12) Lever, 13) Turbine shaft, 14) Shaft seal, 15) Bearing, 16) Flexible coupling, 17) Generator (Voith Siemens Hydro)

**Specific speed** This is the speed at which a runner will rotate if the runner diameter is such that, under 1 ft (1 m) net head, it will develop 1 hp (1 kW):

$$\text{In USCS units} \quad N_s = \frac{\text{rpm} \times \text{hp}^{1/2}}{\text{ft}^{5/4}}$$

$$\text{In SI units} \quad N_s = \frac{\text{rpm} \times \text{kW}^{1/2}}{\text{m}^{5/4}}$$

The specific speed is an important factor governing the selection of the type of runner best suited for a given operating range. The impulse wheels have very low specific speeds



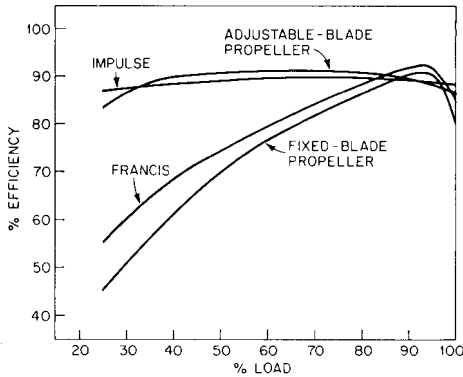


FIGURE 9 Efficiency versus load for different runner types

relative to propellers, and the specific speed of a Francis turbine lies between the impulse and propeller. Table 1 shows some statistics for existing units.\*

## SIZES AND RATINGS

Although power-recovery turbines are relatively small, there are much larger turbines in existence that could be used to drive pumps. Turbines of the following sizes do exist: propeller, 405.5-in (10.3-dm) diameter; Francis, 288-in (7.3-m) diameter; and impulse, 176-in (4.5-m) diameter. The extreme range of power, head, and speed is shown in Table 2.

## GENERAL CHARACTERISTICS

**Sigma** As in pumps, the problem of cavitation also exists in turbines. Sigma is defined as follows:

$$\sigma = \frac{H_a - H_s}{H}$$

where  $H_a$  = feet (meters) of atmospheric pressure minus vapor pressure

$H_s$  = distance in feet (meters) the centerline of the blades is above tailwater for vertical units or distance in feet (meters) the highest point of the blade is above tailwater for horizontal units

$H$  = feet (meters) of elevation between inlet head water surface and tailwater surface elevation

Critical sigma is defined as that point at which cavitation begins to affect the performance of the turbine. Figure 10 shows the relationship between critical sigma and specific speed and also shows which type of runner is best for a given specific speed. The impulse

\*Universal specific speed  $\Omega_u$  (defined in Chapter 1 and Section 2.1) is found from these turbine  $N_s$ -values as follows:

$$\Omega_u = \frac{N_s(USCS)}{4.344\sqrt{\eta_t \times \text{sp. gr.}}} = \frac{N_s(SI)}{16.564\sqrt{\eta_t \times \text{sp. gr.}}}$$

where  $\eta_t$  is the turbine efficiency in percent.

**TABLE 1** Turbine statistics of existing units

Speed, rpm	Power, hp <sup>a</sup>	Head, ft <sup>b</sup>	$N_s$ , USCS <sup>c</sup>	Type <sup>d</sup>	Use <sup>e</sup>	Supplier <sup>f</sup>
450	2,000	925	3.94	I	SUP	BLH
450	450	485	4.19	I	SUP	BLH
750	170	575	3.47	I	SUP	BLH
340	570	485	3.57	I	SUP	BLH
1,775	264	1,085	4.63	I	SUP	BLH
437.5	425	405	4.97	I	SUP	BLH
1,770	640	960	8.38	I	SUP	BLH
1,775	230	1,085	4.32	I	SUP	BLH
720	885	460	10.05	I	SUP	BLH
900	640	866	4.85	I	SUP	BLH
3,550	85	1,920	2.58	I	SUP	BLH
690	535	86.5	60.50	F	FW	BLH
126	670	80	13.63	F	FW	BLH
450	2,600	118	58.90	F	SUP	LEF
525	1,050	83.5	67.39	F	SUP	LEF
900	750	123	60.18	F	SUP	LEF
1,000	375	96	64.43	F	SUP	LEF
700	53	150	9.71	I	SUP	LEF
750	160	30	135.13	P	SUP	LEF
882	128	70	49.26	F	SUP	LEF
1,750	145	135	45.78	F	SUP	LEF
1,750	220	135	56.39	F	SUP	LEF
280	200	14	146.20	P	SUP	A-C
550	400	35	129.21	P	IR	A-C
3,450	7.5	196	12.89	I	PP	A-C
1,775	353	1,085	5.36	I	ST	A-C
1,185	280	231	22.01	I	ST	A-C
1,775	300	1,510	3.27	I	CH	A-C
1,300	1.6	150	3.13	I	PP	A-C
700	1,760	798	6.92	I	ST	A-C
600	392	460	5.58	I	SUP	A-C
122	973	65	20.61	F	FW	A-C
108	1,200	75	16.95	F	FW	A-C

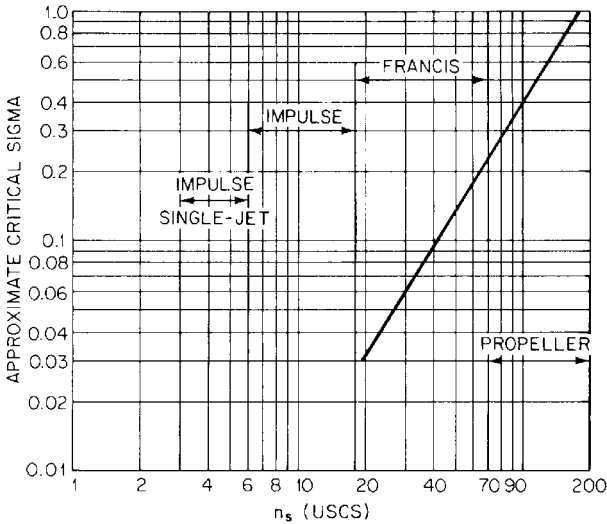
<sup>a</sup>kW = 0.746 hp<sup>b</sup>m = 0.3048 ft<sup>c</sup> $N_s$  (SI) = 3.814  $N_s$  (USCS)<sup>d</sup>I = impulse, P = propeller, F = Francis<sup>e</sup>SUP = supplement electric motor to drive pump, FW = drives fishway pumps, ST = scrubber-tower application, PP = turbine drives petroleum pumps, CH = power recovery in chemical plant, IR = irrigation project.<sup>f</sup>BLH = Baldwin-Lima-Hamilton Corp., LEF = The James Leffel Co., A-C = Allis-Chalmers Corporation, since 1986 Voith Hydro, Inc., also American Hydro Corp.

wheel is not affected by sigma because it is a free jet action and therefore not subject to low-pressure areas.

**Affinity Laws** The relationships between head, discharge, speed, power, and diameter can be seen in the following equations, where  $Q$  = rate of discharge,  $H$  = head,  $N$  = speed,  $P$  = power,  $D$  = diameter, and subscripts denote two geometrically similar units with the same specific speed:

**TABLE 2** Range of power, head, discharge, and speed of existing units of one manufacturer

	Propeller		Francis		Impulse	
	Low	High	Low	High	Low	High
Power hp <sup>a</sup>	82.5	268,000	1.2	820,000	1.6	330,000
Head ft <sup>b</sup>	6.0	180	4.0	2,204	75.0	5,790
Speed, rpm	50	750	56.4	3,500	180	3,600

<sup>a</sup>kW = 0.746 hp<sup>b</sup>m = 0.3048 ft**FIGURE 10** Critical sigma versus  $N_s$ . Specific speed  $N_s$  (SI) = 3.814  $N_s$  (USCS)

$$\frac{Q_1}{N_1 D_1^3} = \frac{Q_2}{N_2 D_2^3}$$

$$\frac{Q_1^2}{H_1 D_1^4} = \frac{Q_2^2}{H_2 D_2^4}$$

$$\frac{N_1^2 D_1^2}{H_1} = \frac{N_2^2 D_2^2}{H_2}$$

$$\frac{P_1}{N_1^3 D_1^5} = \frac{P_2}{N_2^3 D_2^5}$$

Most designs used are tested as exact homologous models, and performance is stepped up from the model by the normal affinity laws given above. Because of difficulties in measuring large flows at the field installation, only approximate or relative flow metering is normally done.

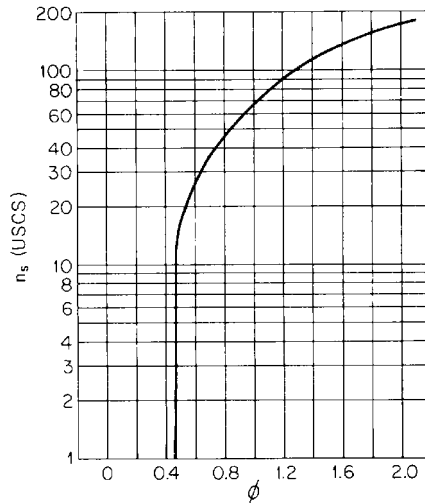


FIGURE 11 Specific speed versus  $\phi$ . Specific speed  $N_s$  (SI) =  $3.814N_s$  (USCS)

**Speed Characteristic** This is defined as the peripheral speed of the runner divided by the spouting or free discharge velocity of the water:

$$\phi = \frac{u}{(2gH)^{1/2}}$$

where  $\phi$  = speed characteristic

$u$  = peripheral speed of runner, ft/s (m/s)

$H$  = head, ft (m)

$g = 32.2 \text{ ft/s}^2$  ( $9.807 \text{ m/s}^2$ )

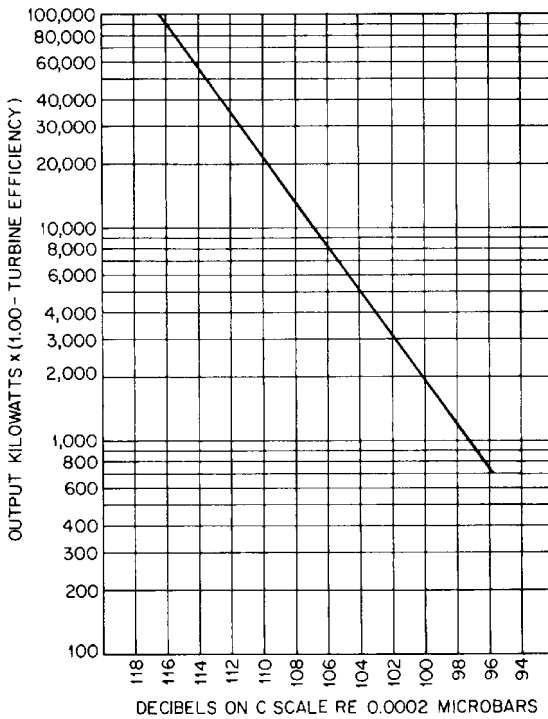
A plot of  $\phi$  versus speed can be seen in Figure 11, which shows that  $\phi$  becomes constant after the specific speed has dropped into the impulse-runner region. Theoretically, for maximum energy conversion,  $\phi$  should equal 0.5 for impulse runners. However, because of small losses in the runner, this value is set at approximately 0.46. Control of the hydraulic turbine can be accomplished by means of a governor or a flow or load control system.

**Torque** All hydraulic turbines have maximum torque at zero speed; therefore, they have ideal starting characteristics. The pump can be accelerated to design speed by gradually opening the turbine gates or inlet valve while keeping within the limitations of hydraulic transients.

#### DATA REQUIRED FOR TURBINE SELECTION \_\_\_\_\_

The turbine supplier should have the following information in order to select the best combination of size and type runner:

1. Head available, head range, and head duration.
2. Power and speed required to drive pump.



**FIGURE 12** Sound level readings taken 3 ft (0.9 m) from main shaft. Hydraulic losses are approximated output in kilowatts  $\times$  (1.00 - turbine efficiency). (From L. F. Henry: "Selection of Reversible Pump/Turbine Specific Speeds." Paper presented at meeting on pumped-storage development and its environmental effects, University of Wisconsin, September 1971.)

3. Description of fluid to be handled, including chemical composition and specific gravity.
4. Possibility of adding air to system. Turbine will operate satisfactorily without air, but air may be added to system to reduce pressure fluctuations (normally one-third of rpm in frequency) at part load and possibly to smooth unit operation at full load.
5. If corrosive fluid is to be handled, description of the materials required.
6. Controls from pumping process that will affect turbine operation. If speed is a controlling factor, the possibility of using a speed-varying device should be considered.
7. Back pressure on the turbine.
8. Noise-level trends for the turbine. Figure 12 illustrates noise levels recorded on some rather large turbine units. Ear protection is required for noise levels above 85 db.

### FURTHER READING

ASME Hydro Power Technical Committee. "The Guide to Hydropower Mechanical Design." HCI Publications, Inc., 1996.

Daugherty, R. U, and Ingersoll, A. C. *Fluid Mechanics*. McGraw-Hill, New York, 1954.

Henry, L. F. "Selection of Reversible Pump/Turbine Specific Speeds." Paper presented at meeting on pumped-storage development and its environmental effects, University of Wisconsin, September 1971.

Roth, H. H., and Armbruster, T. F. "Starting Large Pumping Units." *Allis-Chalmers Eng. Rev.* 31 (3)(1966).

Schlichting, H. *Boundary Layer Theory*. McGraw-Hill, New York, 1960.

Stepanoff, A. J. *Centrifugal and Axial Flow Pumps, 2nd edition*. Krieger Publishing, Malabar, Florida, 1957.

Warnick, C. C. "Hydropower Engineering." Prentice Hall, New Jersey, 1984.

Wilson, P. N. "Turbines for Unusual Duties." *Water Power*. June 1971.

# 6.1.5 GAS TURBINES

RICHARD G. OLSON

## THERMODYNAMIC PRINCIPLE AND CLASSIFICATIONS

---

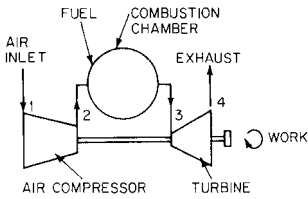
The gas turbine is an internal combustion engine differing in many respects from the standard reciprocating model. In the first place, the process by which a gas turbine operates involves steady flow; hence pistons and cylinders are eliminated. Secondly, each part of the thermodynamic cycle is carried out in a separate apparatus. The basic process involves compression of air in a compressor, introduction of the compressed air and fuel into the combustion chamber(s), and finally expansion of the gaseous combustion products in a power turbine. Figure 1 illustrates a simple gas turbine.

**The Brayton, or Joule, Cycle** Figure 2 shows an ideal Brayton, or Joule, cycle illustrated in  $PV$  and  $TS$  diagrams. This cycle is commonly used in the analysis of gas turbines.

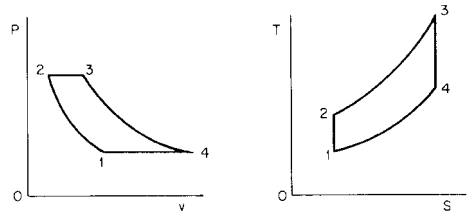
The inlet air is compressed isentropically from point 1 to point 2, heat is added at an assumed constant pressure from point 2 to point 3, the air is then expanded isentropically in the power turbine from point 3 to point 4, and finally heat is rejected at an assumed constant pressure from point 4 to point 1. From Figure 2, the compressor work is  $h_2 - h_1$ , the turbine work is  $h_3 - h_4$ , and the difference is the net work output. The heat input is  $h_3 - h_2$ . One can then derive an expression for thermal efficiency as follows:

$$\eta = \frac{(h_3 - h_4) - (h_2 - h_1)}{h_3 - h_2}$$

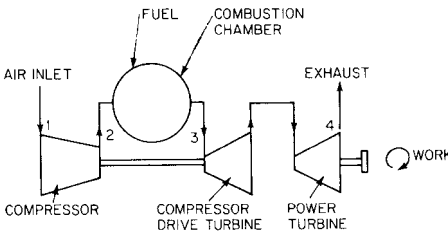
In reality, the cycle is irreversible and the efficiency of the compression, combustion, and expansion must be taken into account. However, an examination of the thermal efficiency equation shows the need of high compressor and turbine efficiencies in order to produce an acceptable amount of work output. The importance of  $h_3$  is also readily apparent.



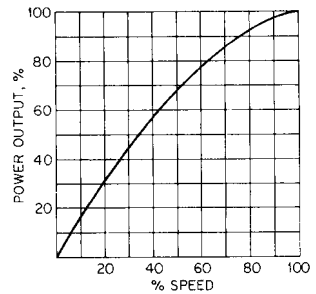
**FIGURE 1** Components of simple gas turbine



**FIGURE 2** PV and TS diagrams for an ideal Brayton, or Joule, cycle



**FIGURE 3** Components of a split-shaft gas turbine



**FIGURE 4** Typical curve of power output versus shaft speed for a split-shaft gas turbine

In noting that  $h_3$  is directly proportional to temperature, one can appreciate why continuous emphasis is being placed on the development of materials and techniques that permit higher combustion temperatures and correspondingly higher turbine inlet temperatures.

**Classifications** In an *open-cycle* gas turbine, the inlet air mixes directly with the combustion products and is exhausted to the atmosphere after passing through the power turbine. The *closed-cycle* gas turbine uses a heat exchanger to transfer heat to the working fluid, which is continuously recirculated in a closed loop. A *combined cycle* uses the principles of both the open and closed cycles. In current practice, the combined cycle uses an open cycle to provide shaft work while the heat from the exhaust is partially recovered in a waste-heat boiler. The heat recovered then proceeds through a standard steam power cycle until heat is rejected to the most readily available low-temperature reservoir.

Of the above configurations, the open-cycle gas turbine is most extensively used today for driving centrifugal pumps. This is probably due to the important consideration of minimum capital investment for each power output.

Two distinct types of open-cycle gas turbines have evolved: the *single-shaft* and *split-shaft* versions. The single-shaft gas turbine was developed primarily for the electric power industry and uses a compressor and a power turbine integrated on a common shaft. As the unit is used continuously at a single rotational speed, the compressor and power turbine efficiency can be optimized.

The split-shaft gas turbine was developed primarily for mechanical drive applications where output power and speed might be expected to vary. Figure 3 illustrates such a turbine. A typical curve of power output versus shaft speed is illustrated in Figure 4.

Split-shaft gas turbines are available in *conventional* and *aircraft-derivative* versions. The conventional gas turbine evolved from steam turbine technology and is illustrated in



Figure 5. Figure 6 shows a modified jet engine used as a source of hot gas to a power turbine. Note that the jet engine combines the compression, combustion, and power turbine necessary to drive the compressor.

## RATINGS

---

In the evolution of the gas turbine as a prime mover, various organizations have put forth standard conditions of inlet temperature and elevation to allow direct comparison of various gas turbines.

Four common standards exist:

*ISO* (International Standards Organization): sea level and 59°F (15°C)

*NEMA* (National Electrical Manufacturers Association): 1000 ft (304.8 m) above sea level and 80°F (27°C)

*CIMAC* (Congres International des Machines a Combustion): sea level and 59°F (15°C)

*Site*: actual elevation and design temperature at installation site

With the evolution of higher combustion temperatures and with the greater need for power over relatively short daily periods, new ratings have developed: emergency (maximum intermittent), peaking (intermittent), and base load. These classifications are based on the number of hours per unit of time that a gas turbine is operated and are related to the material used in the power turbine blading. A common standard is to use materials suitable for 100,000 h of continuous operation. Higher temperatures are permitted, but at the sacrifice of the life of the material and an increase in maintenance costs.

In a pump-driving application, the cycle of operations should be considered in specifying a gas turbine driver. A typical curve of gas turbine output as a function of inlet temperature (Figure 7) clearly indicates the necessity of specifying an accurate design temperature. Figure 8 is a typical correction curve for altitude.

## FUELS

---

A wide range of fuels, from natural gas to the bunker oils, may be burned in simple-cycle gas turbines. In most cases, units can operate on gas or liquid fuels, and some turbines have automatic switchover capability while under load.

Although it would appear advantageous to choose the cheapest fuel available, there may be disadvantages in such a choice: impurities such as vanadium, sulfur, and sodium definitely result in high-temperature corrosion; solid impurities and a high ash content will lead to erosion problems. One is therefore often faced with a trade-off between the cost of treating a fuel and the higher original cost.

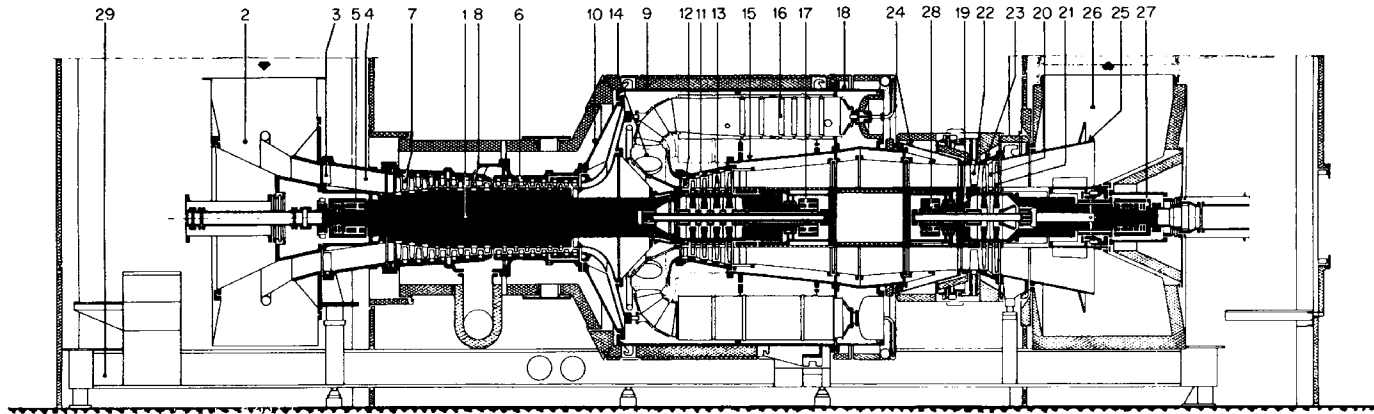
With ever-increasing firing temperatures, research is continuing in the field of high-temperature corrosion with or without accompanying erosion problems. Present approaches to the problem include the use of inhibitors in the fuel as well as coatings for power turbine blades. Another solution that has been used on some crude oil pipelines is the topping unit. This is a small still that removes a specific fraction of the crude oil for burning as gas turbine fuel. It is good practice to include a detailed fuel analysis as part of any request for bids.

## ENVIRONMENTAL CONSIDERATIONS

---

Legislation at both the federal and state levels has been concerned with the protection of our environment. An engineer must now consider the effects of the project on the environment.

**Noise** Any piece of dynamic mechanical equipment will emit airborne sounds that, depending on frequency and level, may be classified as noise.



**FIGURE 5** Gas turbine cross section: (1) gas generator turbine rotor, (2) inlet air casing, (3) compressor inlet guide vanes, (4) conical inlet casing with bearing support, (5) compressor radial-axial bearing, (6) compressor stator, (7) compressor stator blades, (8) compressor rotor blades, (9) combustion chamber main casing, (10) intermediate conical casing with diffuser, (11) gas generator turbine stator blade carrier, (12) gas generator turbine stator blades, (13) gas generator turbine rotor blades, (14) hot gas casing, (15) intermediate casing, (16) nine incorporated combustion chambers, (17) compressor radial bearing, (18) central casing, (19) power turbine rotor, (20) power turbine stator blades, (21) power turbine rotor blades, (22) power turbine adjustable rotor blades, (23) power turbine stator blade carrier, (24) conical intermediate piece, (25) outlet diffuser, (26) outlet casing, (27) power turbine radial-axial bearing, (28) power turbine radial bearing, (29) metallic foundation (Turbodyne)

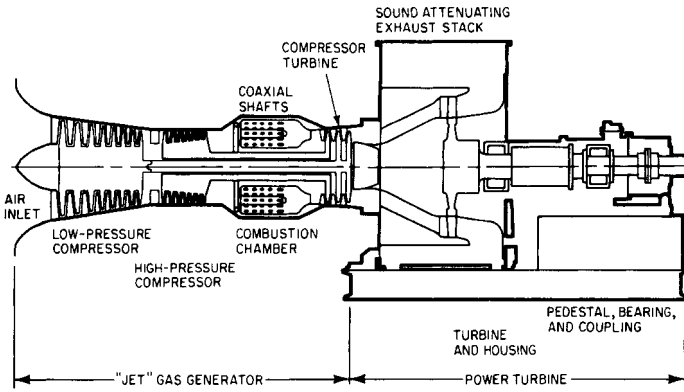


FIGURE 6 Cross section of aircraft-derivative gas turbine driver (Turbodyne)

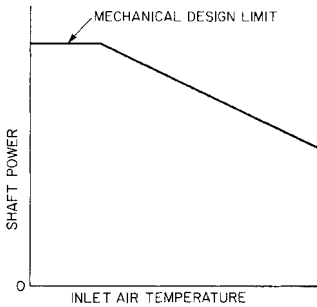


FIGURE 7 Typical curve of gas turbine output versus inlet temperature

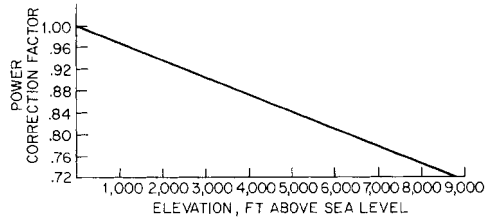


FIGURE 8 Typical curve of gas turbine power correction versus altitude (ft  $\times$  0.3048 = m)

The primary sources of noise in the gas turbine are the turbine inlet and exhaust and the accessories and support systems, such as fin fan lubrication oil coolers, auxiliary air blowers and fans, starting devices, and auxiliary lubrication oil pumps. It is common practice for manufacturers to provide inlet and exhaust silencers as well as some form of acoustic treatment for auxiliaries.

In considering the degree of acoustic treatment necessary for each installation, the practicing engineer must consider the following parameters:

1. Federal law (Walsh-Healy Act) limiting the time a worker may spend in a noisy environment
2. Local codes and their interpretation
3. Plant location and existing noise level at site
4. Site topography, including any noise-reflective surfaces
5. Applicable ASME standards and other relevant standards

**Emissions** The federal air quality acts require each state to develop a plan for achieving satisfactory air quality. Specifically, goals have been put forth to limit suspended particulate temperature matter and oxides of sulfur and nitrogen. Therefore,

the engineer must investigate existing regulations during the planning stage of a pump installation.

In general, gas turbines have low particulate emissions. The amount of sulfur oxides exhausted to the atmosphere is in direct proportion to the content of sulfur in the fuel, and current practice calls for elimination at the source. The formation of oxides of nitrogen is a direct result of combustion. Manufacturers are currently committing a considerable amount of resources to the investigation and solution of this problem.

## **GAS TURBINE SUPPORT SYSTEMS**

---

**Starting Systems** A form of mechanical cranking is necessary to bring a gas turbine up to its self-sustaining speed. The amount of energy necessary will depend on each manufacturer's design. Available systems include electric motors, diesel engines, and gas-expander turbines.

**Lubrication** The gas turbine manufacturer normally provides a combined pump-turbine lubrication oil system. A main lubrication oil pump of sufficient capacity for the combined system is necessary, in addition to a standby pump in the event of failure of the main pump. A reservoir sized for a retention time of at least four minutes is usually specified. Filtration to 10- $\mu$ m particle size should be adequate for most gas turbines and pumps.

Lubrication oil can be cooled by various means, the selection of which depends upon local conditions. The simplest and cheapest method uses a shell-and-tube heat exchanger with water as the cooling medium. In arid regions, a fin fan cooler with direct air-to-water cooling is commonly used.

**Inlet Air Filtration** The degree of inlet air filtration needed is primarily a function of the size and number of particles in the atmosphere surrounding the installation. In most cases, a simple tortuous-path precipitator will suffice. For dirtier atmospheres or in arid regions where sandstorms occur, inertial separators followed by a rolling-media filter should be considered.

Any filtration will result in a loss in performance because of the pressure drop across the inlet filter. Conservative design practice calls for a face velocity of 500 ft/min (150 m/min) for a rolling-media filter and 1700 ft/min (520 m/min) for a tortuous-path precipitator.

**Control** Most manufacturers offer control packages which provide proper sequencing for automatic start-up, operation, and shutdown. During automatic start-up, the sequencer receives signals from various transmitters to ensure that auxiliaries are functioning properly and, with the aid of timers, brings the unit on line through a planned sequence of events.

Key operating parameters—for example, output speed, gas turbine compressor speed, turbine inlet temperature, lubrication oil temperature and pressure—are continually monitored during normal operation. Signals from a pump discharge-pressure transmitter can be fed into a speed and fuel controller to cause the unit to respond to changes in speed and output.

As with start-up, normal and emergency shutdowns are accomplished through the sequencer. Most standard control packages are easily adaptable to remote control by means of cable or microwave.

## **APPLICATION TO PUMPS**

---

Gas turbines are available to drive centrifugal pumps in a wide range of speeds and sizes, from 40 hp (30 kW) to over 20,000 hp (15,000 kW). It is not practical to list here all the avail-

able units because they are too numerous and are continually being upgraded and added to. A listing can be found in *Sawyer's Gas Turbine Catalog*, which is published annually.

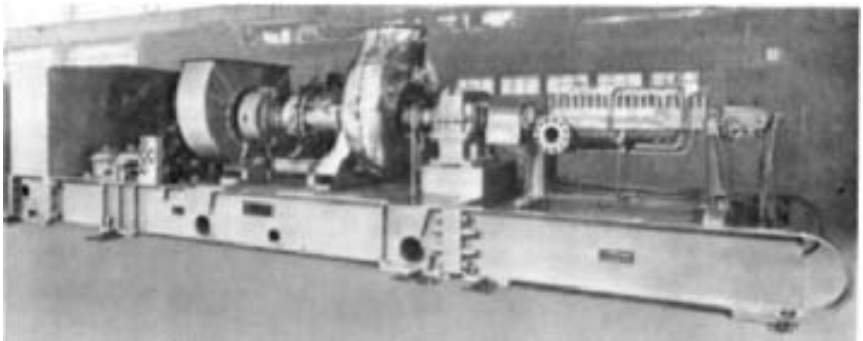
**Pipeline Service** Crude oil pipeline service has seen a tremendous growth in the use of gas turbine drivers since the mid-1950s, and this trend will continue as crude oil production becomes more and more remote from its markets. The advantages of the gas turbine for this application are as follows:

1. Installed cost is usually lower than that of a corresponding reciprocating engine.
2. Variable-speed operation allows maintenance of a specific discharge pressure under a wide range of operating conditions, thus achieving maximum flexibility.
3. Normal gas turbine control system is easily adapted to unattended operation and remote control.
4. Operating experience has proved the gas turbine to have a high degree of reliability.
5. Gas turbines can be packaged into modules for ease of transportation and erection.

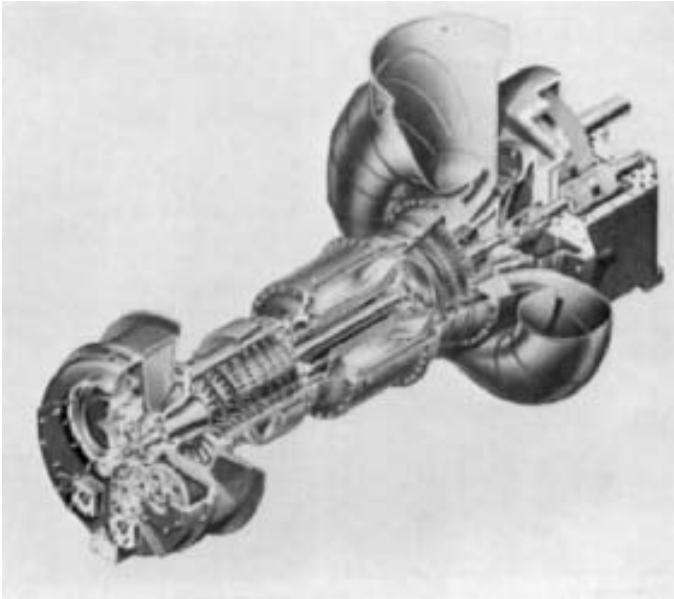
**Water Flooding** An important aspect of oil production is the use of secondary recovery methods to increase the output of crude oil reservoirs whose pressure does not allow the crude to flow freely to the surface. Flooding the reservoir with high-pressure water has been a primary technique for years. The development of high-pressure centrifugal pumps has allowed increased water flow into oil fields.

As most oil production is located in remote areas, the packaged gas turbine driver has become increasingly popular. Figure 9 shows a typical 3300-bhp (2460-brake kW) split-shaft gas-turbine-driven centrifugal water flood pump package. A cutaway view of a typical 1100-hhp (820-brake kW) gas turbine is shown in Figure 10; note the reduction gearing at the exhaust end for direct driving of a pump. Supporting systems, such as starter, lubrication oil pumps, governor, and fuel oil pumps, are driven off the accessory pods located at the air inlet end. Offshore platform installations require drivers with a minimum vibration as well as small, unbalanced inertial forces. The gas turbine fits both of these descriptions very well.

**Cargo Loading** Another interesting application of this prime mover is in the field of cargo loading, where units are currently in operation charging tankers with crude oil. Selection of a gas turbine pumping unit with critical speeds above the normal operating range allows great flexibility of operation, particularly during final topping operations.



**FIGURE 9** A 3300-bhp (2460-bkW) gas turbine-driven waterflood package (Solar Division of International Harvester)



**FIGURE 10** Cutaway view of 1100-bbp (820-bkW) split-shaft gas turbine driver (Solar Division of International Harvester)

**Application Considerations** The application of gas turbine drivers can vary from a simple driver for one pump operating at constant flow and discharge pressure to a multiplicity of units operating at variable speed on a pipeline. For the purposes of this discussion, it is assumed that the pumping system has been analyzed, a pump selection has been made, and all possible operating conditions have been analyzed so brake horsepower (brake kilowatt) and speed requirements are known.

The brake horsepower (brake kilowatt) output of the gas turbine must equal or exceed that required by the pump. This output can be determined by the use of specific performance curves similar to Figure 7 as corrected for elevation (Figure 8). Gear losses as necessary are added to the brake horsepower (brake kilowatt) required by the pump. Intermediate brake horsepower (brake kilowatt) and speed requirements should then be checked against a gas turbine output versus speed curve (Figure 4).

A torsional analysis of the combined unit is made (usually by the gas turbine manufacturer) to ensure the absence of any critical speeds in the operating range. Table 1 is a typical data sheet recommended for use when purchasing a gas turbine to drive a centrifugal pump.

**TABLE 1** Typical data sheet for gas turbine driven centrifugal pump

Information from purchaser	Information from manufacturer		
<b>Pumping requirements</b>	<b>Pumping requirements</b>		
Service _____	Service _____		
Liquid _____	Liquid _____		
Pumping temp. _____	Pumping temp. _____		
Capacity (total) normal/max _____/_____	Capacity (total) normal/max _____/_____		
No. pumps operating _____	No. pumps operating _____		
Specific gravity at pump temp. _____	Specific gravity at pump temp. _____		
Viscosity at pumping temp. _____	Viscosity at pumping temp. _____		
Total head _____	Total head _____		
NPSH available _____	NPSH available _____		
<b>Pump type, materials, and accessories</b>	<b>Bhp (brake W)</b>		
	required	normal	max
	Speed, rpm	normal	max
	Efficiency	normal	max
<b>Site conditions</b>	<b>Pump type, materials, and accessories</b>		
Elevation, ft (m) _____	<b>Gas turbine excluding gear</b>		
Range of site ambient temperature	Design	Max	Min
	Dry bulb		
	Wet bulb		
Design, °F (°C) _____			
Maximum, °F (°C) _____			
Minimum, °F (°C) _____			
<b>Atmospheric air</b>	<b>Dry bulb temp., °F (°C)</b>		
Dust below 10 $\mu\text{m}$ , ppm _____	Output, hp (kW)		
10 $\mu\text{m}$ and above, ppm _____	Heat rate,		
Corrosive constituents:	Btu/hp · h		
Sulfur, ammonia, ammonium salts,	(J/kWh) (LHV)		
salt or seacoast, other _____	Output shaft		
	speed, rpm		
	Turbine inlet		
	temp., °F (°C)		
	Gear loss		
	Net hp (kW)		
<b>Noise specifications</b>	<b>Total utility consumption</b>		
City, state, federal, other _____	Cooling water, gpm (l/s)		
	Electric power, kW ac/dc		
	Steam, lb/h (kg/h)		
	Compressed air, standard		
	ft <sup>3</sup> /min (m <sup>3</sup> /min)		
<b>Emission specifications</b>	<b>Shipping data</b>		
City, state, federal, other _____		Turbine	Aux.
		items	
	Shipping wt, tons (kg)		
	Max erection wt, tons (kg)		
	Max maint. wt, tons (kg)		
	Length, ft-in (m)		
	Width, ft-in (m)		
	Height, ft-in (m)		
<b>Utilities available at site</b>			
Steam: Pressure, lb/in <sup>2</sup>			
(kPa) gage _____			
Temp., °F (°C) _____			
Quantity, lb/h (kg/h) _____			
<b>Electricity</b>			
V	Phase	Cycles	
ac _____			
dc _____			
<b>Cooling water</b>			
Source _____ quality _____			
Supply temp. _____ min _____ max			
Supply press, lb/in <sup>2</sup>			
(kPa) gage _____			
Max return, °F (°C) _____			

**TABLE 1** Continued.

Information from purchaser	Information from manufacturer	
Fuel Gas _____ liquid _____	Accessories included (as required by purchaser)	
Analysis attached	Inlet air filter	___yes ___no
Accessory items required (see list in right-hand column)	Inlet air silencer	___ ___
	Exhaust silencer	___ ___
	Exhaust duct	___ ___
	Starting equipment	___ ___
	Load gear (if required)	___ ___
	Driven pump	___ ___
	Coupling	___ ___
	Fire protection system	___ ___
	Equipment enclosure	___ ___
	Baseplate or soleplates	___ ___
	Combined turbine-pump	___ ___
	Lub. oil system	___ ___
	Main lube pump	___ ___
	Auxiliary lub. pump	___ ___
	Lub. reservoir	___ ___
	Lub. filter	___ ___
	Lub. oil cooler	___ ___
Unit control panel	___ ___	
Auxiliary motor	___ ___	
Control center	___ ___	

Source. Adapted from API Standard 616.

### **FURTHER READING**

Baumeister, T., and Marks, L. *Standard Handbook for Mechanical Engineers*. 8th ed. McGraw-Hill, New York, 1978.

Combustion Gas Turbines for General Refinery Services, API Standard 616, 1982.

Dacy, I. R. "Gas Turbines Used on Arctic Pipelines." *Oil Gas J.* 200:26, 1973.

Proposed Gas Turbine Procurement Standard, ASME.

Sawyer, J. W., ed. *Sawyer's Gas Turbine Engineering Handbook*. 3rd ed. Gas Turbine Publications, Stamford, CT, 1985.

Schiefer, R. B. "The Combustion of Heavy Distillate Fuels in Heavy Duty Gas Turbines." *ASME* 71-GT-56, 1971.

Shepherd, D. G. *Introduction to the Gas Turbine*. 2nd ed. Van Nostrand, Princeton, NJ, 1960.



---

# SECTION 6.2

---

# SPEED-VARYING DEVICES

---

## 6.2.1 EDDY-CURRENT COUPLINGS

W. J. BIRGEL  
S. A. MOLL

---

### **DESCRIPTION**

---

The eddy-current coupling is an electromechanical torque-transmitting device installed between a constant-speed prime mover and a load to obtain adjustable-speed operation. Generally ac motors are the most commonly used pump drives, and they inherently operate at a fixed speed. Insertion of an eddy-current slip coupling into the drive train will allow desired adjustments of load speeds.

In most cases, the eddy-current coupling has an appearance very similar to that of its driving motor except that the coupling has two shaft extensions. One shaft, which operates at constant speed, is connected to the motor, whereas the other shaft, providing the adjustable-speed output, is connected to the load. A typical self-contained air-cooled eddy-current slip coupling is shown in Figure 1.

The input and output members are mechanically independent, with the output magnet member revolving freely within the input ring or drum member. An air gap separates the two members, and a pair of antifriction bearings maintain their proper relative position. The magnet member has a field winding that is excited by direct current, usually from a static power supply. Application of this field current to the magnet induces eddy currents in the ring. The interaction between these currents and magnetic flux develops a tangential force tending to turn the magnet in the same direction as the rotating ring. The net result is a torque available at the output shaft for driving a load. An increase or decrease in field current will change the value of torque developed, thereby allowing adjustment of the load speed. Field current, output torque, and load speed are usually not proportional. Therefore load torque characteristics and speed range must be known for proper adjustable-speed drive size selection.

Most eddy-current couplings have load speed control. An integral part of this system is a magnetic pickup that provides an indication of exact output speed and enables control of load speeds within relatively close tolerances regardless of reasonable variations in load

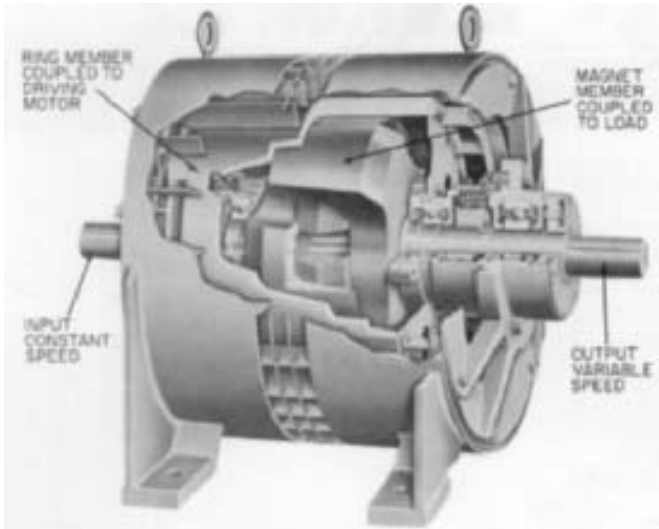


FIGURE 1 Cutaway of an Ampli-Speed eddy-current slip coupling (Electric Machinery Mfg.)

torque requirements. Slip-type adjustable-speed drives without load speed control will experience fluctuations in load speed when load torque requirements vary.

## FUNDAMENTALS

The eddy-current coupling, like many other adjustable-speed drives, operates on the slip principle and is classified as a torque transmitter. This means that the input and output torques are essentially equal, disregarding frictional and windage losses. The motor input power is equal to the sum of load power and what is known as slip loss. This slip loss is the product of slip speed, which is the difference between motor and load speed, and the transmitted torque.

The various relationships may be expressed as follows:

$$\text{In USCS units} \quad \text{Motor hp} = \frac{\text{rpm}_1 \times T}{5250}$$

$$\text{In SI units} \quad \text{Motor kW} = \frac{\text{rpm}_1 \times T}{9545}$$

$$\text{In USCS units} \quad \text{Load hp} = \frac{\text{rpm}_2 \times T}{5250}$$

$$\text{In SI units} \quad \text{Load kW} = \frac{\text{rpm}_2 \times T}{9545}$$

$$\text{In USCS units} \quad \text{Slip loss (hp)} = \frac{(\text{rpm}_1 - \text{rpm}_2) \times T}{5250} = \frac{\text{rpm}_3 \times T}{5250}$$

$$\text{In SI units} \quad \text{Slip loss (kW)} = \frac{\text{rpm}_3 \times T}{9545}$$

This may be further expressed as follows:

$$\text{In USCS units} \quad \text{Slip loss (hp)} = \frac{\text{rpm}_3}{\text{rpm}_2} \times \text{load hp}$$

$$\text{In SI units} \quad \text{Slip loss (kW)} = \frac{\text{rpm}_3}{\text{rpm}_2} \times \text{load kW}$$

Or

$$\text{In USCS units} \quad \text{Slip loss (hp)} = \frac{\text{rpm}_3}{\text{rpm}_1} \times \text{motor hp}$$

$$\text{In SI units} \quad \text{Slip loss (kW)} = \frac{\text{rpm}_3}{\text{rpm}_1} \times \text{motor kW}$$

where  $\text{rpm}_1$  = motor speed at designated load

$\text{rpm}_2$  = load speed at designated load

$\text{rpm}_3$  = slip speed at designated load

$T$  = load torque, ft · lb ( $N \cdot m$ )

An eddy-current coupling must slip in order to transmit torque. The normal minimum value of slip for a centrifugal pump application is usually 3%, but values from 1 to 4% are common. The above formulas hold true regardless of the type of load involved.

The efficiency of an eddy-current coupling can never be numerically greater than the percentage that the output speed is of the input motor speed. This effectively takes into consideration only the slip losses, and a true efficiency value must also include frictional, windage, and plus excitation losses. The frictional and windage losses are constant for a fixed motor speed and therefore increase in significance with speed reduction. Excitation losses, on the other hand, decrease with reduction in output speed. The overall effect of these losses is an efficiency versus speed relationship that is somewhat linear with efficiency values anywhere from 1 to 4 points less than the output speed percentage.

## LOAD CHARACTERISTICS

---

In the application of slip couplings for continuous pump loads, both variable- and constant-torque requirements are encountered.

**Variable-Torque Loads** Variable-torque loads are those where the torque increases with the speed and varies approximately as the square of the speed while the load power varies approximately as the speed cubed. The centrifugal pump fits into this classification. To be specific, the above torque-power-speed relationship exists only where the friction head is the total system head, as would be the case if a centrifugal pump were pumping from and to reservoirs having the same liquid levels or in a closed loop.

The various relationships of load power, motor power, and slip loss applying to a typical variable-torque load are shown in Figure 2—again frictional and windage losses have been disregarded.

Static heads, which usually exist in centrifugal pump systems, do not significantly affect the selection of a suitable slip coupling for a specific requirement. Pump efficiency, on the other hand, can be quite an important factor when it decreases significantly with speed reduction. Pumps with relatively flat efficiency curves are most desirable for adjustable-speed duty.

Centrifugal pumps usually operate against some static head. This causes the pump torque to follow a closed discharge characteristic until sufficient speed is reached to cause the resultant discharge head to equal or exceed the static head. This is equivalent to a closed discharge or normally unloaded condition. The pump load then follows a different curve to the full-load condition at minimum slip. These characteristics are illustrated in Figure 3. Curve *OAB* indicates the closed discharge power. At point *A* the static head is overcome, and

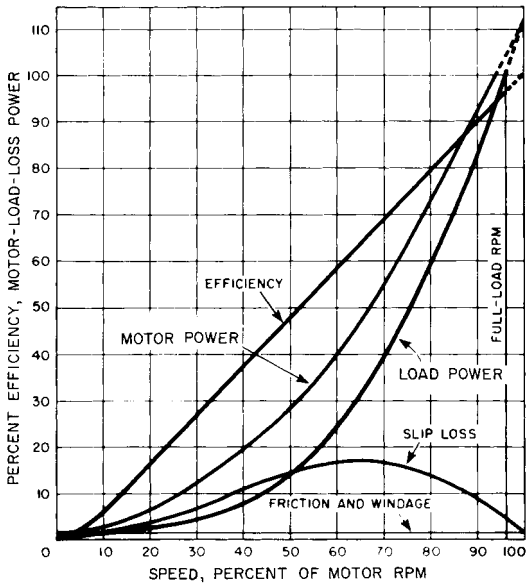


FIGURE 2 Load, power, and slip characteristics for a friction-only pumping system

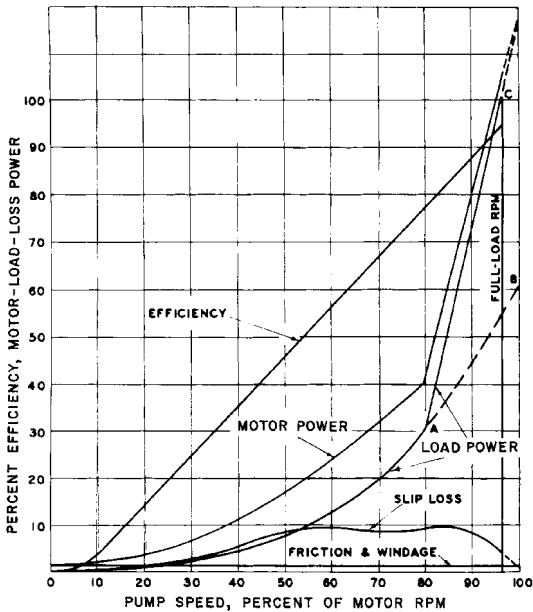


FIGURE 3 Percent efficiency, motor load loss power versus pump speed in percent of motor speed for a static head and friction pumping system

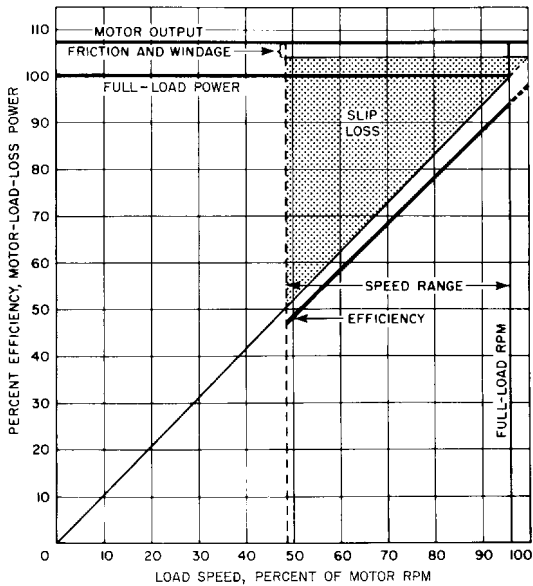


FIGURE 4 Power, torque, and losses for a constant-torque load

the pump load then rises along curve *AC*; this causes a significant difference in slip loss as shown. Under conditions as indicated, where static head is not exceeded and water does not start to flow until 80% of full speed is reached, the slip loss never exceeds 10% of the full-load rating. In general, this is true of a pump with high static head.

**Constant-Torque Loads** Constant-torque loads are those requiring essentially constant torque input regardless of operating speed. Positive displacement pumps generally are of this type. The load characteristics showing the division between slip loss and load power are illustrated in Figure 4. Note that the driving motor output does not change, regardless of load speed and power.

The slip loss characteristics make slip couplings undesirable for large power loads if any appreciable speed range is required. However, in relatively small units, the simplicity and ease of speed control will frequently justify the use of slip couplings instead of more efficient but more complex speed-control systems.

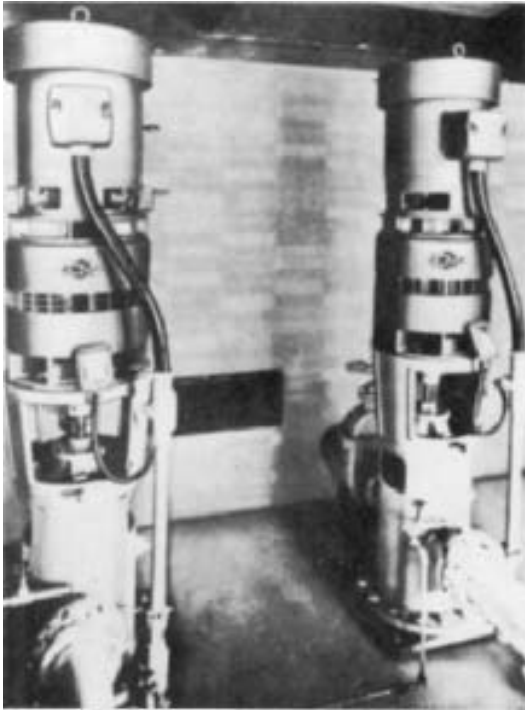
The constant-torque-load capacity of a slip coupling is largely limited by slip loss and, to a lesser degree, by breakaway torque and minimum slip. Because slip loss is directly proportional to slip, the desired speed range will definitely limit the torque, and therefore the power, that can be transmitted. In some cases, breakaway torque is important as the static friction may be quite high. It is usually recommended that at least 150% of starting torque be available for any constant-torque load.

## CONSTRUCTION

Eddy-current couplings are available in both horizontal (Figure 5) and vertical (Figure 6) configurations as might be required for any pump mechanical arrangement. Horizontal machines in smaller sizes are frequently close-coupled to the drive motor in what is known as *integral construction*. Larger sizes are usually flexibly coupled to the drive motor and pump load.



**FIGURE 5** Horizontal centrifugal pump driven by a 1000-hp (746-kW), 1780-rpm induction motor through a stepup gear and an eddy-current coupling (Electric Machinery)



**FIGURE 6** Vertical centrifugal pumps driven by 40-hp (30-kW), 1750-rpm induction motors and eddy-current couplings (Electric Machinery)

Vertical motors and slip couplings are close-coupled to limit overall height and to prevent vibration problems. Pump hydraulic thrust requirements can be accommodated, when necessary, in much the same way as in constant-speed motor applications. Because of mechanical limitations, thrust bearings are frequently located in the bottom of the adjustable-speed drive.

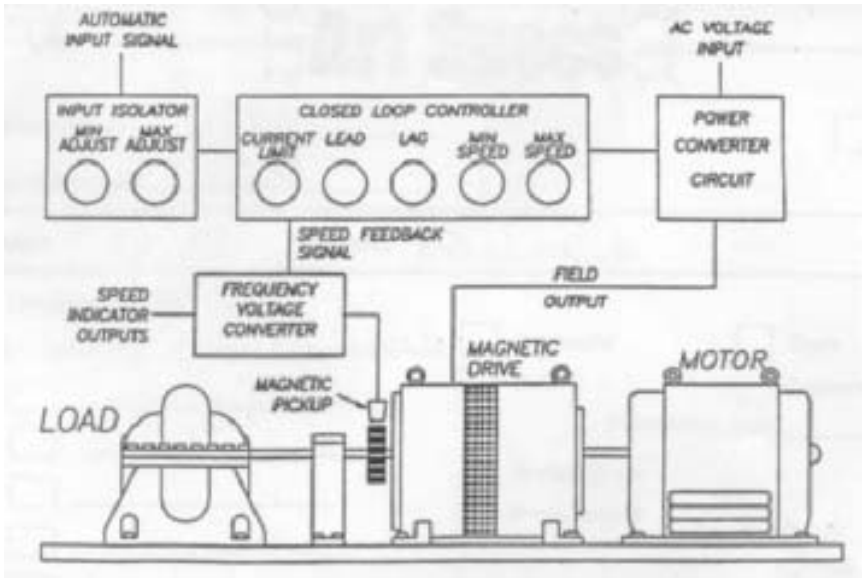


FIGURE 7 Interconnection block diagram of eddy-current clutch and speed control

Enclosures available will vary depending on the type of cooling involved. Obviously water-cooled types need little if any enclosure adaptation for virtually any installation. However, caution should be exercised in outdoor use where freezing can occur. Also, vertical installations utilizing water cooling may require special considerations.

Air-cooled couplings are more universally used for centrifugal pump loads but do require attention on enclosure design. Indoor installations in clean atmospheres need only open or drip-proof enclosures where heat rejection is not a problem. In some cases, intake and discharge covers for connection to ductwork may be necessary for environmental isolation.

Weather-protected enclosures are available for outdoor installations, A NEMA Type I rating is normally adequate because of the slip coupling's inherent mechanical design and relatively low field winding voltage levels.

## CONTROLS

The speed control is designed to operate with a magnetic drive equipped with a magnetic pickup. The controller contains a signal isolator to allow precise speed adjustment from an automatic 4–20 ma (milliamperes) of 0–10 VDC (volts DC) control signal. The control has a closed loop control circuit, field firing circuit, current feedback loop, and SCR (silicon-controlled rectifier) power stage for controlling the output speed of the magnetic drive. The control also has an acceleration/deceleration ramp circuit that is an integral part of the control circuit for smooth acceleration of the load—especially important for many types of pump loads.

The input signal is fed through an isolation circuit or from the manual speed adjustment pot to the controller circuit. The controller circuit outputs a regulated voltage and current to the field firing circuit. This voltage/current output is also regulated by the current feedback sensed by the resistor network and the speed signal from the magnetic pickup to assure precise speed regulation. The field firing circuit regulates the firing timing of the SCRs. By using multiple loopback feedback circuits, speed regulation is held with .2% of the set speed.

The controller circuit has a current limiting adjustment that controls the maximum current from the SCR circuit to the drive field to eliminate any excess current in the drive coils. This protects from overpowering the drive and causing unnecessary heating.

The controller power circuits convert 120–480 VAC (volts AC) into DC voltage. The DC voltage is converted to the required voltage of the drive field by the SCR firing circuit using pulse width modulation. The circuits are protected by circuit breakers and metal oxide varistors.

## **APPLICATIONS**

---

Slip couplings are applied to centrifugal pumps for water and waste-water pumping in municipal installations, for boiler-feed pumping, for circulating water and condensate pumping in power plants, for fan and stock pumping in paper mills, and for reciprocating pumping in a multitude of applications and industries.

In the water and waste-water fields, slip couplings are used extensively for raw- and finished-water pumping, lift-station pumping, raw-sewage pumping, and effluent and sludge pumping. Almost any pumping problem, where cyclic constant-speed pumping or throttling or other means of flow control are alternate considerations, can be conveniently solved with the use of an eddy-current slip coupling as the adjustable-speed flow controlling device.

Potable water treatment and distribution facilities are continually confronted with substantial fluctuations in demand through daily, weekly, and even seasonal periods. Distribution systems that depend on direct pumping usually must utilize total or partial adjustable speed operation for high-service and booster requirements. The quick response of eddy-current slip couplings makes them extremely well suited for this duty.

Waste-water collection systems, where inflow conditions to lift stations and treatment plants vary widely throughout the day, can realize many advantages when designs are based on adjustable speed with eddy-current slip couplings.

## **RATINGS AND SIZES**

---

Eddy-current couplings are available in a wide range of ratings and sizes, from fractional power units up through 10,000 hp (7500 kW) and beyond. The type of cooling employed is an important consideration; some manufacturers use either water or air exclusively and others use a combination of the two. In addition, the type of load is a factor because thermal capability will vary significantly between water- and air-cooled units.

Centrifugal pump variable-torque loads are usually best handled by air-cooled couplings having high-torque capabilities at low slip values and limited heat-dissipating capabilities. The selection chart shown in Table 1 is representative of one manufacturer's line of couplings designed specifically for centrifugal pump loads. Where full-torque capabilities are realized at 3% slip below motor speed, thermal loads at two-thirds of motor speed will be 16.2% of rated speed load power. Sizes starting at 3 to 5 hp (2.2 to 3.7 kW) and extending up through 3000 to 5000 hp (2240 to 3730 kW) are generally available.

Eddy-current couplings for pump loads requiring constant-torque drives have rather limited usage. In small sizes where thermal capabilities are proportionately greater than the 6:1 ratio encountered on large units, constant-torque loads can be adequately handled by air-cooled couplings. Beyond 100 hp (75 kW), air-cooled units can be impractical because of thermal and starting-torque requirements.

Water-cooled eddy-current couplings have somewhat different characteristics, making them more suitable for constant-torque and large-power variable-torque loading. High starting torque, high minimum slip, and high thermal capabilities all tend to lead to those conclusions. Thermal capabilities are frequently equal to or greater than full-load power ratings. The starting torque is usually the maximum torque, and as a result low slip values are limited.



**TABLE 1** Eddy-current coupling selection chart for centrifugal pumps, horsepower output (1hp = 0.746 kW)

Drive motor input speed, rpm	Unit Size	Percent of motor full-load speed			
		99	98	97	96
1750	S209	370	420	405	395
	S238	630	610	597	579
	S276	820	800	775	750
	S326	1150	1100	1065	1030
	S376	1800	1750	1700	1650
1150	S209	160	290	305	295
	S239	400	470	455	442
	S276	440	615	600	580
	S326	910	870	844	818
	S376	1300	1270	1230	1190
870	S209	100	170	225	240
	S239	250	336	375	364
	S276	300	355	490	480
	S326	650	718	696	675
	S376	1100	1080	1050	1000
700	S209			160	185
	S238			200	210
	S239	170	250	316	316
	S276	250	310	365	375
	S326	420	580	597	579
	S376	950	920	900	860
	S209			110	135
585	S238			140	160
	S239			223	270
	S276		240	270	280
	S326	300	510	520	507
	S376	430	610	600	576
	S209				100
	S238				135
495	S239				200
	S276			205	235
	S326	220	380	410	460
	S376	740	710	700	670
	S209				80
	S238				115
	S239				167
435	S276				190
	S326	170	310	330	390
	S376	640	670	650	630
	S209				150
	S326			275	320
	S376	530	600	585	565
	S448	650	950	1000	980
385	S529	1650	1790	1750	1680

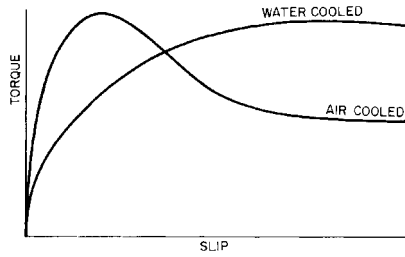


FIGURE 8 Speed-torque curves for variable-torque air-cooled and constant-torque water-cooled couplings

TABLE 2 Typical eddy-current coupling downthrust capabilities, lb<sup>a</sup>

Unit size	Motor speed, rpm					
	1,750	1,150	870	700	585	495
S209	2,920	3,530	4,080	4,580	4,860	5,180
S239	2,240	2,860	3,410	3,910	4,190	4,500
S276		3,900	4,605	5,170	5,670	6,150
S326		2,545	3,260	3,810	4,290	4,780

<sup>a</sup>1 lb = 4.45 N.

Figure 8 illustrates the differences in the speed-torque curves of variable-torque air-cooled and constant-torque water-cooled couplings.

### THRUST CAPABILITIES FOR VERTICAL UNITS

Most vertical eddy-current couplings have limited external downthrust load capabilities when provided with standard bearing arrangements. Typical values are listed in Table 2 for the sizes listed in Table 1. Bearing life is an important factor, and the values shown are based on a minimum life of five years in accordance with manufacturer's standards at an average output speed of 85% of input speed. Bearings are angular-contact ball type with grease lubrication. Where higher thrust values are encountered or where longer bearing life or adherence to ABMA life standards must be met, spherical roller bearings or plate-type hydrodynamic thrust bearings with oil lubrication can be furnished.

## 6.2.2

# SINGLE-UNIT ADJUSTABLE-SPEED ELECTRIC DRIVES

E. O. POTTHOFF  
J. R. HENDERSHOT

In past years, the electric motor industry has been dominated by the use of essentially single and constant speed motors when line fed. There were many mechanical methods used to achieve adjustable speed using a single-speed prime mover. There was also widespread use of dc motors for adjustable speed over the last century because only the voltage must be adjusted for speed change. Although operation at speeds well below synchronous can be accomplished through adjustment of the secondary resistance in wound-rotor induction motors, the ubiquitous squirrel-cage ac induction motor requires the adjustment of the frequency to change speed. This was not so easily accomplished until the recent utilization of pulse width modulation (PWM) inverters with insulated gate bipolar transistors (IGBTs) for power transistors plus microprocessors.

Electric drives are available featuring a single rotating element and some associated control for performing the adjustable-speed driving function. The use of a single rotating element differentiates this type of drive from the eddy-current coupling motor, hydraulic coupling motor combinations, and adjustable-speed belt drives, all of which are tandem drives.

The speed of the single-unit adjustable-speed drive is controlled through the interaction of the control and the motor. For this reason, one must consider these two elements as a drive and not consider the motor alone.

Subsection 6.1.1 described motors that will be further discussed in this subsection. Previous discussions of control were limited to that required for starting and protection; this subsection will also describe specific controls required for speed control. The discussion will cover the following types of drives:

- Ac adjustable-voltage drives
- Wound-rotor induction motors with several different types of secondary controls
- Adjustable-frequency drives

- Modified Kraemer drives
- Dc motors with silicon-controlled rectifier (SCR) power supplies

All have physical features, operating characteristics, or prices that make them particularly valuable in some specific segment of the pump driver spectrum.

### ALTERNATING-CURRENT ADJUSTABLE-VOLTAGE DRIVES

This drive consists primarily of an adjustable voltage, constant frequency control, and a motor (M) conveniently configured as shown in Figure 1. The motor must possess high slip characteristics and other characteristics that allow it to work successfully with the associated control. The motor is designed for operation and tested with its associated control. Because the motor has high slip characteristics, insulation is of Class F rating.

The fundamental parts of the control are a circuit protective device, such as a circuit breaker, an SCR assembly, and firing circuitry, identified as FC in Figure 1. Other parts are required to complete the control but serve as auxiliaries. The main function of this control is to provide a voltage to the motor at a level that will ensure a desired motor speed. The control also protects the motor under abnormal operating conditions and the motor cable under short-circuit conditions and provides a current-limit function so the motor draws a maximum of some preselected value, such as 150% of normal, under all operating conditions.

The SCR receives impressed voltage, usually at 60 Hz. The SCR can be turned on (or become conducting) by means of current pulses received from the firing circuits that energize the circuits at different points on the sinusoidal wave. After conductance starts, it continues until voltage disappears at the end of the half-cycle. The SCR must be pulsed again in order to become conducting. This occurs while the voltage is in the negative phase of its sinusoidal generation and is performed by an SCR connected in parallel to the first and having reverse polarity. The negative loop conductance continues until the voltage again returns to zero. The firing controls are designed to turn the SCR on repetitively sometime during each voltage half-cycle. Figure 1A shows the shape of the applied voltage between the SCR and the motor for the wave illustration shown. In this case, the SCR is turned on at the beginning of each half-cycle.

By delaying the firing, or turning on, of the SCR until later in voltage generation, shorter intervals of applied voltage and lower levels of voltage appear across the motor. The solid line of Figure 1B illustrates applied motor voltage when the voltage half-wave is half-completed. Figure 1C illustrates the motor-applied voltage when the half-waves are approximately 75% completed. Notice in these illustrations that the frequency of the voltage applied to the motor does not vary; only the voltage magnitude does.

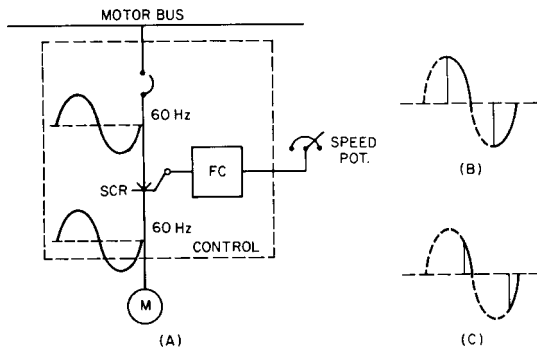


FIGURE 1A through C Block diagram for ac adjustable-voltage drive (General Electric)

The exact point in the half-wave when firing occurs is controlled by a low-energy electronic signal that may come from a potentiometer, as in Figure 1A, or from some process instrument signal. By increasing the signal level, voltage applied to the motor increases; on the other hand, a decrease in signal level decreases the voltage level.

Figure 1A shows the SCR on the utility side of the motor as a convenience in illustration. In reality, the SCR is generally placed at the motor neutral point. This reduces voltage from the SCR to ground and allows the motor impedance to protect the SCR somewhat from damage caused by transient voltage spikes entering from the electric utility line. However, placing the SCR at the motor neutral point does require the use of six motor conductors instead of the conventional three.

Figure 2 illustrates representative motor speed-torque curves at rated and other voltages as well as a pump speed-torque curve varying as the square of the speed. The motor possesses approximately 10% slip under rated torque and voltage conditions. Note that motor torque does not break down at speeds lower than breakdown torque speed. These various characteristics help to identify the motor as one designed to operate specifically for this application. Note that by reducing applied motor voltage, motor torque decreases, causing the pump to operate at lower speed.

Ratings of these drives are limited essentially to low power levels. Figure 3 provides a guide to those available in open construction only. All ratings with maximum rated speeds existing within the solid envelope are available. Some, but very few, are available outside of this envelope. Totally enclosed motors are more restricted in supply than open motors and are limited to approximately 40 hp (30 kW) maximum. In addition to these restrictions, load torques must not exceed values varying as the square of the speed; thus this drive is not a candidate for driving a constant-torque load. Table 1 gives some pertinent application information.

## WOUND-ROTOR INDUCTION MOTORS

**Liquid Rheostat Controls** This form of drive consists primarily of a full-voltage, non-reversing (FVNR) starter, a wound-rotor induction motor, and a liquid rheostat, all of which integrate into a configuration as illustrated in Figure 4. The FVNR starter switches power to and from the motor stator as well as provides generally accepted protection to

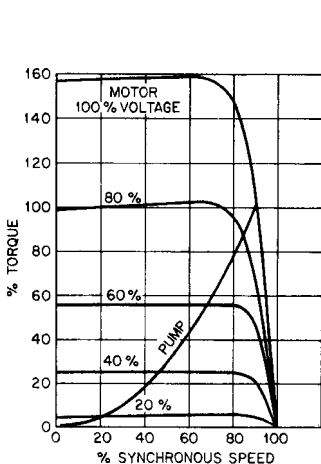


FIGURE 2 Torque versus speed for ac, adjustable-voltage drive (General Electric)

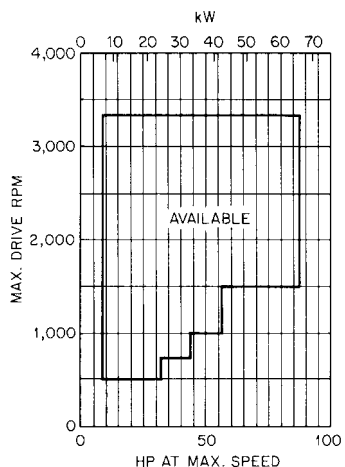
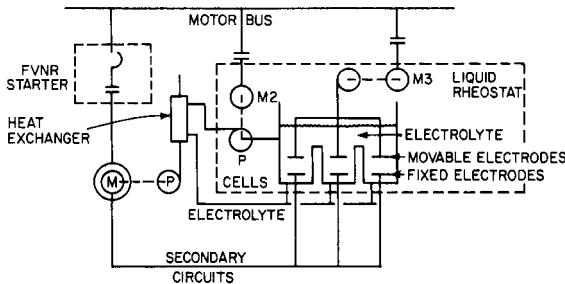


FIGURE 3 Availability of ac adjustable-voltage drives

**TABLE 1** Alternating-current adjustable-voltage drive data

Drive element	Power rating <sup>a</sup>	Voltage rating	Max rated speed, rpm	Speed range, %	Enclosure	Mounting	No. of speed points
Motor	See Figure 3 for open frame ratings; limited availability outside these limits	200	1640	100	Vertical: shielded drip-proof; TEFC not generally available	Vert. or horiz.	Infinite
		230	1095	820			
		460	655	545 & others			
	Totally enclosed ratings limited as shown under Enclosure				Horizontal: drip-proof, TEFC to 40 hp (30 kW) approx.		
Control	5–150 hp (3.7–112 kW)	200	...	...	NEMA 1	Wall or floor	Infinite
		230			NEMA 12		
		460					

<sup>a</sup>Drive is capable of operating with power varying as the cube of speed maximum. Specifically, these ratings are not suitable for constant-torque applications.



**FIGURE 4** Block diagram for wound-rotor induction motor with liquid rheostat secondary power (General Electric)

the motor from short circuits, overloads, and so on. Secondary cables connect the motor rotor and fixed electrodes in the liquid rheostat. The fixed electrodes exist in separate cells of the rheostat, one for each phase. Movable electrodes, one located in each cell, are suspended from a horizontal bar, and this bar, the vertical-electrode suspension bars, the movable electrodes, and the electrolyte filling the cells complete the Y, or common point in the external motor rotor circuit. When the upper electrodes are moved up or down, the secondary circuit resistance of the drive varies and this causes a change in the motor speed-torque characteristic.

As already pointed out, the motor starter provides the normal protective functions for the motor. Control circuitry allows the motor to be started with maximum secondary resistance in the rotor circuit, thus drawing minimum motor current from the power supply.

Figure 4 illustrates a motor (M3) operating a pulley that changes the position of the movable electrode. This motor could be controlled manually by a push button or automatically through a controller position providing either a raise-lower or modulated voltage signal. If desired, a pneumatic cylinder may substitute for motor M3 to provide power to move the electrodes.

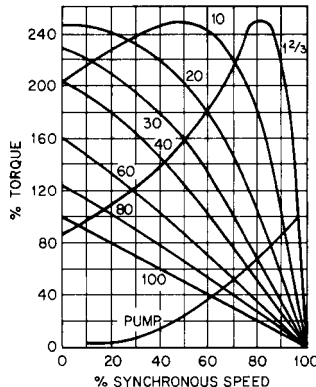
The electrolyte receives the drive slip losses dissipated in each of the cells, and of course this heat must be removed into some heat sink capable of dissipating it. In some installations, an electrolyte pump driven by motor M2 circulates the electrolyte through a heat exchanger before returning it to the individual cells. Returning cooled electrolyte re-enters the cells under the fixed electrodes and passes through holes in the electrodes before passing vertically through the cells. The heat exchanger primary coolant can be tap water or mill water, which provides a good means of passing drive slip losses as heat directly out of the station, or it can be the pump discharge water, which conveys heat directly away from the building, as illustrated in Figure 4.

The liquid rheostat is factory-assembled with the rheostat, electrolyte pump, and its motor and electrode-positioning assembly packaged in a single steel enclosure suitable for control lineups except for ratings above 700 hp (522 kW). The heat exchanger may be of the sleeve (or wrap-around) type, as illustrated in Figure 4, and comes as a separate device to be attached to station effluent piping. Other forms of exchangers, such as liquid-to-air or shell- and-tube heat exchangers, are available.

Changing the position of the movable electrode results in a change in motor speed-torque relations, as shown in Figure 5. Each curve shown (except the pump curve) represents a motor characteristic for a discrete secondary resistance. Notice the number associated with each curve; it represents the percentage of secondary resistance external to the motor rotor; 100% ohms provide 100% motor torque at zero speed. In examining individual curves, note that as the percent resistance increases, the slope of the motor speed-torque curve decreases, thus allowing the motor to slide down the pump speed-torque curve and assume a lower speed.

This drive utilizes resistance only in the motor secondary circuit as a means of controlling speed. Reactance is available as a substitute for resistance in other forms of secondary controllers, but its use reduces the drive power factor and thereby increases motor current, reduces efficiency, and increases motor heating. As a further effect, the additional motor current may require the use of a larger motor frame to accommodate it.

Figures 6A, B, and D provide clues to the availability of enclosed vertical and horizontal wound-rotor induction motors. Figure 6A illustrates the point that vertical, totally enclosed wound-rotor induction motors are not generally available but may be available in random powers and speeds. Totally enclosed water-to-air-cooled (TEWAC) construction becomes available at some minimum point as illustrated. In large ratings, shown on the right, TEWAC construction becomes very important as it provides a convenient way of capturing motor losses and expelling them in cooling water external to the building. Both curves of Figure 6A terminate at 1800 rpm synchronous speed because higher speed ratings are generally unavailable.



**FIGURE 5** Torque versus speed for wound-rotor induction motor with variable secondary resistance (General Electric)

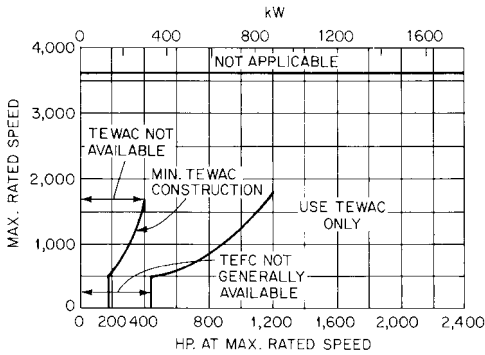


FIGURE 6A Approximate availability of totally enclosed vertical wound-rotor induction motors (General Electric)

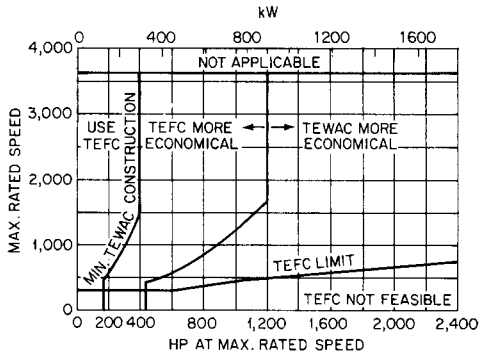


FIGURE 6B Approximate availability of totally enclosed horizontal and vertical squirrel-cage induction motors and horizontal wound-rotor induction motors. Wound-rotor induction motor speeds limited to 1800 rpm maximum (General Electric).

Figure 6B delineates the left side, where totally enclosed fan-cooled (TEFC) construction should be used for horizontal wound-rotor induction motors because it is the only one available, the middle area, where TEFC construction should be used because it is less expensive than TEWAC construction, and, finally, the right side, where TEWAC construction is less expensive than TEFC construction. Again, motor speeds are limited to 1800 rpm synchronous.

Vertical wound-rotor induction motors are not available in explosion-proof construction, as their omission from Figure 6C implies.

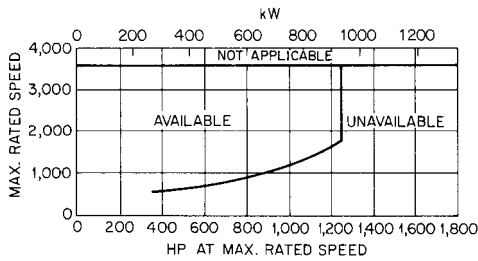
Finally, the areas of availability and unavailability are delineated in Figure 6D for horizontal wound-rotor induction motors in explosion-proof construction. Again, the curve terminates at 1800 rpm synchronous speed for reasons already expressed.

Delineation of motor availability is an important criterion in drive selections. Table 2 presents significant data useful in drive selection.

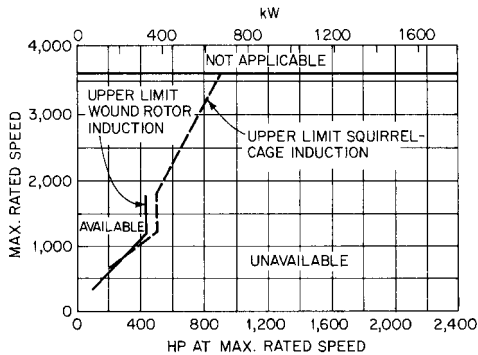
**Tirastat II\* Secondary Controls** This drive utilizes the same wound-rotor induction motor and FVNR starter as the preceding, but substitutes a Tirastat II controller for the

\*Trademark of General Electric Co.





**FIGURE 6C** Approximate availability of explosion-proof vertical squirrel-cage induction motors (General Electric)

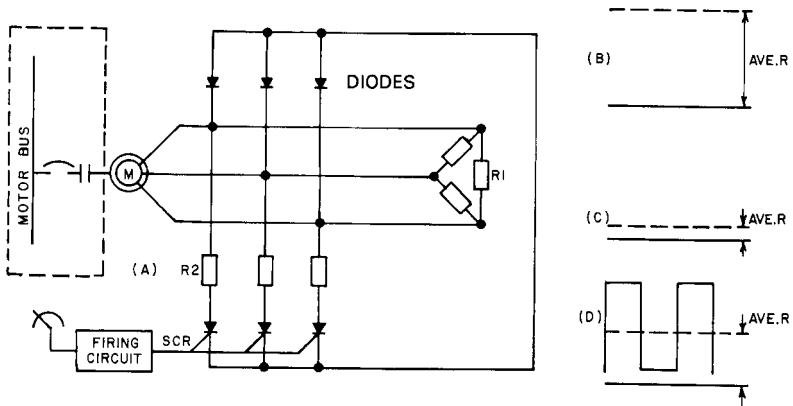


**FIGURE 6D** Approximate availability of explosion-proof horizontal squirrel-cage and wound-rotor induction motors (General Electric)

**TABLE 2** Wound-rotor induction motor with liquid rheostat drive data

Drive element	Power rating <sup>a</sup>	Voltage rating	Max rated speed, rpm	Speed range, %	Enclosure	Mounting	No. of speed points
Motor	No limits for open motors; see Figure 6A, B, D for restrictions by enclosure	Any NEMA standard	All established by number of motor poles and supply frequency	60	Vertical: shielded dripproof, TEFC generally not TEWAC available per Figure 6A Horizontal: dripproof, TEFC, explosion-proof per Figure 6D	Vert. and horiz.	Infinite
Control	25 hp (18.7 kW) min; no stated max	For any motor secondary voltage	...	60	NEMA 1	Lineup or singly Floor only	Infinite

<sup>a</sup>Drive may be designed for constant torque or for torque varying at the square of the speed.



**FIGURE 7** Block diagram for wound-rotor induction motor with Tirastat II secondary control power (General Electric).

liquid rheostat. Figure 7A shows the configuration with the wound-rotor induction motor and starter identical to those of Figure 4.

The Tirastat controller in its simplest form consists of the components shown in Figure 7A. Resistors identified as R1 are permanently connected across the motor secondary phases. Additional resistors (R2) are connected across motor phases through SCR and diodes. The SCR are individually turned on (become conducting) by minute current pulses generated by the firing circuit. As the voltage loop across any SCR drops to zero, the SCR shuts off and does not turn on again until the firing circuit refires it. The diodes allow return of the current to the motor but block out current reversals to the SCR.

Drive speed varies as a function of changing controller average resistance. Thus, resistance can be varied by adjusting time on-time off ratios in the SCR to give the desired average resistance. Figure 7B shows controller secondary resistance with the SCR not firing (conducting). In this condition, the controller resistance value equals the resistance of R1. Figure 7C shows controller resistance with all SCR firing continuously. The decrease in resistance is due to additional resistance placed in parallel with resistor R1. Figure 7D shows controller resistance varying from maximum to minimum in approximately equal time periods. The average resistance value then approximates half of the sum of R1 and R2. The time on-time off of the SCR can be varied automatically by the controller to provide the average resistance in the motor circuit necessary to give the desired motor speed.

The motor starter provides normal motor protective functions as well as short-circuit protection of the motor cables and starter. The Tirastat II controller monitors motor current and limits it to some preselected value, such as 150% of normal, under all conditions.

Packaging of the secondary controller is of particular interest. Both packaging and configuration lend themselves to mounting the resistors on or near the control enclosure or removing them some distance from the enclosure. By placing the resistors outdoors or at some indoor location away from the operations, heat losses can be released to the environment with impunity to operators.

The speed-torque ability of this drive would be very close to that illustrated by Figure 5. The comments contained in the text describing that figure apply equally well here. Table 3 presents significant data useful in drive selection.

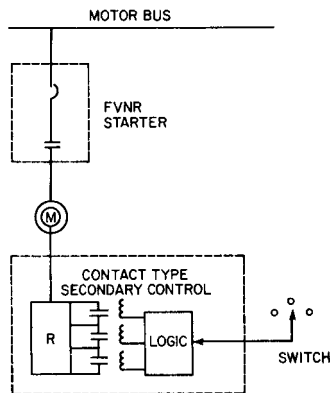
**Contact Secondary Controls** Many pump drives utilize a very simple combination of FVNR starter, wound-rotor induction motor, and a form of contact making secondary control. Figure 8 shows the configuration with a motor and FVNR starter identical with those of Figures 4 and 7A.

The main difference between this drive and the two described previously lies in the construction of the secondary controller and the characteristics of the drive. Resistor R in

**TABLE 3** Wound-rotor induction motor with Tirastat II controller drive data

Drive element	Power rating <sup>a</sup>	Voltage rating	Max rated speed, rpm	Speed range, %	Enclosure	Mounting	No. of speed points
Motor	No limits for open motors; see Figure 6A, B, D for restrictions by enclosure	Any NEMA standard	All established by number of motor poles and supply frequency	60	Vertical; shielded drip-proof, TEFC generally not available, TEWAC available per Figure 6A. Horizontal drip-proof, TEFC, explosion-proof per Figure 6D.	Vert. and horiz.	Infinite
Control	5 hp (3.7 kW) min. 600 hp (448 kW) max.	For any motor secondary voltage	...	50 70	NEMA 1, NEMA 12	Lineup or singly	Infinite

<sup>a</sup>Drive may be designed for constant torque or for torque varying as the square of the speed.



**FIGURE 8** Block diagram for wound-rotor induction motor with magnetic secondary control power (General Electric)

Figure 8 is a three-phase resistor connected across the slip rings of the motor. Its resistance rating is selected to provide minimum motor torque at standstill or adequate torque at minimum speed. Contacts in the form of magnetic contactors, drum, cam, or dial switches are closed by a logic device (generally magnetic) to short-circuit part or all of the resistor. Thus, instead of a modulated or infinitely variable resistor as encountered with the other two drives, this drive modifies secondary resistance in discrete steps, providing discrete speed-torque curves instead of an infinite family. The number of speed-torque curves the control generates will depend directly on the number of contacts provided in the secondary-control circuit.

Either a manual switch or some automatic contact-making device actuated by the process can be utilized to actuate the control logic.

Secondary controls are normally packaged in the factory with resistors and contact-making secondary controller integrally assembled.

**TABLE 4** Wound-rotor inductions motor with contact-type secondary control drive data

Drive element	Power rating <sup>a</sup>	Voltage rating	Max rated speed, rpm	Speed range, %	Enclosure	Mounting	No. of speed points
Motor	No limits for open motors; see Figure 6A, B, D for restrictions by enclosure	Any NEMA standard	All established by number of motor poles and supply frequency	60	Vertical; shielded dripproof, TEFC generally not available, TEWAC available per Figure 6A. Horizontal dripproof, TEFC, explosion-proof per Figure 6D.	Vert. and horiz.	
Control	No limits	For any motor secondary voltage	...	75	NEMA 1	Lineup or singly	Discrete only

<sup>a</sup>Drive may be designed for constant torque or for torque varying as the square of the speed.

The speed-torque capability of this drive would be very close to that illustrated in Figure 5, with the exact number of curves determined by the number of contacts of the contact-making secondary controller and the shape of the curves determined by the resistance selected. Table 4 presents significant data useful in drive selection.

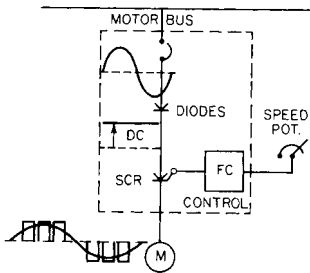
## ADJUSTABLE-FREQUENCY DRIVES

Until recently, the most significant step in the improvement of adjustable drives was to replace the autotransformer and rectified variable voltage power supply with SCR drives. Although dc motors are seldom used for pump drives, except in automotive applications and other special cases, the SCR and PWM adjustable speed dc drives are very highly developed and available from a number of suppliers.

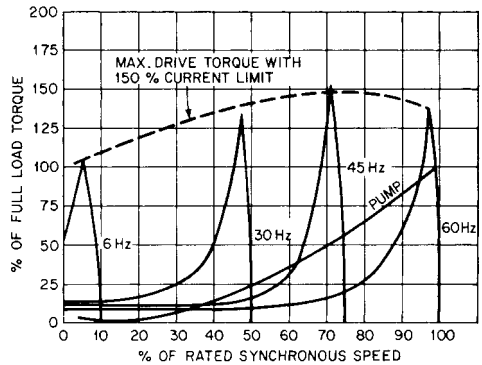
**Pulse Width Modulation Frequency Inverters** Adjustable-frequency drives consist of an adjustable-frequency inverter control and a constant-speed motor, as shown in Figure 9. The inverter control has generally been built in either pulse width modulation or square wave construction. An inverter control consists fundamentally of a circuit-protective device, a diode bridge, and an inverter section having an SCR and a firing-control (FC) section for the SCR, all packaged in a steel enclosure. Special power supplies, motor protective devices, and electrical protective devices complete the package.

Only low voltages are used to energize the motor bus. A diode bridge rectifies voltage and an inverter inverts the direct current into an adjustable-frequency adjustable voltage that varies linearly with frequency. This voltage is not necessarily sinusoidal; it can also consist of a number of dc pulses of positive or negative polarity, as shown between the inverter and the motor in Figure 9. The firing controls modulate the width of the pulses and the number of pulses per half cycle to vary the apparent frequency and to maintain motor voltage at a constant volts-per-cycle. The firing controls automatically introduce additional pulses or withdraw pulses as bandwidths reach their limits.

Firing circuits composed of solid-state devices trigger the SCR in accordance with logic controlled by the setting adjustment of a speed potentiometer (Figure 9) or the signal from the process. The control provides normal protection of the motor as well as short-circuit protection of the control, motor, and cables. Also, the control monitors and limits current drawn by the motor under all conditions to a preadjusted value, such as 150% of normal.



**FIGURE 9** Block diagram for ac adjustable-frequency drive (General Electric)



**FIGURE 10** Torque versus synchronous speed for adjustable-frequency drive (General Electric)

**TABLE 5** Adjustable-Frequency Drive Data

Drive element	Power rating <sup>a</sup>	Voltage rating	Max rated speed, rpm	Speed range, %	Enclosure	Mounting	No. of speed points
Motor	All NEMA ratings for open motors; see Figure 6B, C, D for restrictions by enclosures	460 or 230	All established by number of motor poles and supply frequency	100 plus limited over-speed	Vertical shielded drip-proof, TEFC per Figure 6B, explosion-proof per Figure 6C. Horizontal: drip-proof, TEFC per Figure 6B explosion-proof per Figure 6D.	Vert. or horiz.	Infinite
Control	Up through 800 hp (597 kW); higher ratings available as custom-built units	460 or 230	Capable of producing 150% of rated frequency but at reduced torque	150	NEMA 1 or NEMA 12	Floor	Infinite

<sup>a</sup>Drive may be designed for constant torque or for torque varying as the square of the speed.

Figure 10 displays some representative speed-torque characteristics of the drive utilizing a squirrel-cage induction motor and a representative centrifugal pump. Note that each characteristic intersects the zero-torque point at a different speed value. This differs from those of other drives, illustrated in Figures 2 and 5. The steepness of the slope of each characteristic as it rises from its zero-torque value indicates its low-speed regulation and provides a clue as to its ability to maintain speed with little fluctuation as load torque varies slightly. Motor speed is a function of frequency adjustment; the voltage is adjusted only to accommodate moderate changes in motor impedance. Table 5 lists significant application data.

**Solid State Adjustable Frequency Inverters** The opportunity for adjustable speed for ac induction motors has been realized by the development of the adjustable frequency control as well as the more recent vector drives. Similar adjustable speed drives are now

available for the control of switched reluctance (SR) and permanent magnet (PM) brushless motors. These three technologies are well suited for pump applications that can benefit from adjustable speed.

There are many manufacturers that offer variable frequency with constant or variable voltage IGBT-driven PWM inverters for reliable and performance programmable adjustable speed control of ac induction motors. These drives are available in power up to the hundreds of horsepower (kilowatts). They offer many standard features that can be useful for driving pumps. Some of these are summarized as follows:

- Wide input voltage range allowing standardization of motors.
- Dual frequency operation (50 or 60 Hz)
- PWM output for sine wave voltage at selected output frequency
- Constant or variable torque
- High starting torque at programmable linear acceleration/deceleration
- Over-current protection
- Phase to phase and phase to ground short circuit protection
- Maximum output frequency of 120 Hz for double motor speed
- External contacts for other uses
- Analog speed output proportional to frequency

The use of these types of adjustable speed drives provides pump speed ranges up to nearly twice the base speed of the ac motor. The details of an actual selection of a system should be discussed with an application from a supplier in order to select the right product and size for the pump. An example of a low-power ac inverter is shown in Figure 11.

These classes of solid state adjustable ac motor drives take the 50 or 60 Hz ac line voltage from the grid (wide voltage tolerance range OK) and first rectify it into a dc voltage. Some filter capacitors are sometimes used to attain a smooth dc voltage. Then the dc is converted into sine waves, one for each phase, at a frequency that is selectable to achieve the speed of the motor and pump according to the number of poles in the motor. The drive



**FIGURE 11** Low-power AC inverter (motor controller) for three phase motors with sine wave outputs and an output frequency range from 1 to 120 Hz (courtesy of Leeson Electric Corp.)

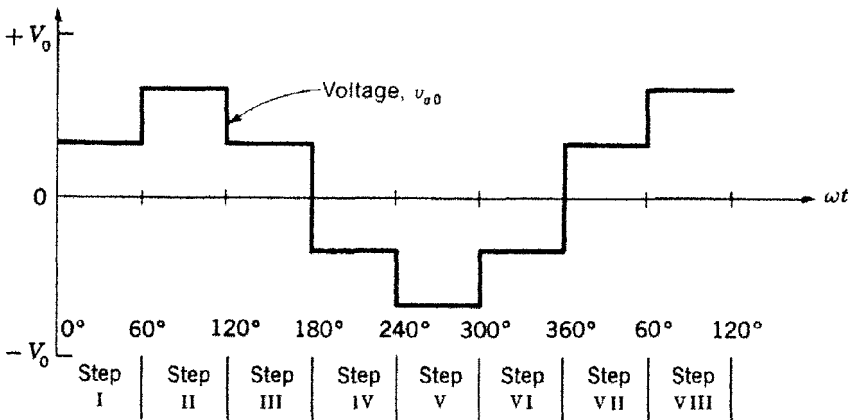


FIGURE 12 AC inverter (6) step simulated sine wave shown for one phase

is designed to maintain a constant volts/Hz relationship. Speed can be controlled to about 10% by inputting the frequency setting. The sine waves can be approximated, as shown in Figure 12, by the use of a simple six-step transistor switching method. Alternatively, they can be very precisely generated using a PWM switching topology at a high carrier frequency to achieve a very low-distortion sine wave. The dynamic response of these systems is sufficient for many pump applications. However, if there are sudden load changes and speed must be accurately maintained, such as for metering pumps, a higher dynamic response will probably be needed. For applications that require high acceleration, the constant volts/Hz algorithm will not allow a fast enough dynamic response because the system bandwidth will likely be too low.

Another problem with these drives is that they usually need a voltage boost at low speeds because of the low frequency. This would be a problem only for metering pumps run over a wide speed range, which is very rare.

**Flux Vector Drives** The highest performance class of solid-state adjustable speed drives for ac induction motors are known as *flux vector drives*. The rectification requirement of the incoming ac power is the same as is the regeneration of sinusoidal currents for each of the three phases to power the motor. The very important difference between them is that the phases are controlled in a closed loop fashion. The control block of the flux vector drive must receive rotor pole angular position feedback information. With this information, the inverter driven ac induction motor can be made to operate like a servomotor. Most flux vector drives utilize a digital signal processor (DSP) for all of the control functions using the software commands programmed by the supplier (user or supplier can modify). These include the various control loops such as speed (within 0.5% if required), acceleration (linear or to a function), current, torque, power, and several more over a very wide speed range. Drives of this type are available for high power with output frequencies of 800 Hz from several suppliers and up to 3 kHz from a few suppliers.

Flux vector drives can achieve a dynamic response in the 10-millisecond range and very smooth speed regulation, down to zero with ordinary induction motors. The concept of the vector control is to observe the present position of the rotor poles and formulate the control to achieve a dc servomotor performance. The control scheme synthesizes the two currents in the motor. If the calculation is done correctly, one of the synthesized currents controls the flux in the motor and the other controls the torque. In other words, one current vector in the stator phases lies along the vector of the rotor flux and the other current vector lies in quadrature or at  $90^\circ$  out of phase. The DSP constantly receives rotor pole position information and constantly recalculates this relationship at all speeds in spite of load changes.

An important feature of flux vector drives is that with simple and minor software modifications they can easily be used to drive PM brushless motors. The drive has transistor gate drivers controlled by the commands from the DSP that receives shaft angle position information from a shaft sensor such as an encoder, resolver, or hall sensors. The poles on the rotor do not move with respect to the shaft and rotor current (true synchronous operation without "slip") as do the poles in the induction motor. It is actually much easier to use this vector flux vector inverter for a PM brushless than for an ac induction motor. This is because there are seldom any calculations to be required to run the brushless motor unless phase advance is needed. However, for pump drives, this requirement seems unlikely.

## MODIFIED KRAEMER DRIVES

Kraemer drives have been used as heavy industrial drives for many years. Although functioning very successfully, each has three rotating units requiring maintenance, and each has significant losses.

In recent years, the advance of semiconductors has simplified the drive configuration to that of Figure 13, which involves an FVNR starter, a wound-rotor induction motor, a solid-state converter, and an acceleration section. The acceleration section and contactors 1 and 2 can be omitted if the converter rating is large. The FVNR starter switches power to the motor and protects both the motor and the converter. Contactor C2, if provided, serves as a synchronizing contactor between converter and power line and is closed only when converter and line frequencies and voltages are compatible. This contactor may be placed on either side of the converter unit.

Under running conditions, rotor slip energy of low voltage and frequency (Figure 13B) flows to the low-frequency side of the converter. The converter unit inverts this voltage to a fixed line frequency. Thus all motor rotor slip energy except converter unit losses are returned to the power source, thereby improving drive efficiency.

Under starting conditions, acceleration occurs with contactor C2 open and C1 closed. Accelerating contactors progressively and automatically short-circuit the resistor H to allow the motor to accelerate to some preselected speed. When converter output voltage and frequency match line values, contactor C2 closes and C1 opens automatically. The drive then operates as already described.

The converter generally consists of a diode bridge and SCRs with their firing circuitry for inverting. Required auxiliaries, such as special power supplies, complete the package.

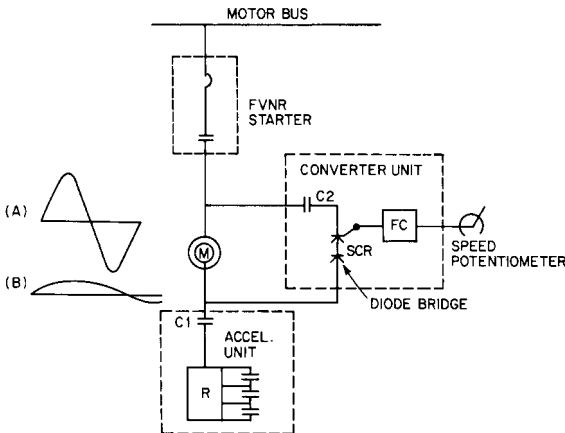


FIGURE 13 Block diagram for modified Kraemer drive



Generally all control materials are packaged in a single lineup to facilitate building and installation.

The motor starter provides normal protection of the motor as well as short-circuit protection of control, motor, cables, and converter. In addition, the converter monitors and limits current drawn from the line under all conditions to a preadjusted value, such as 150% of normal.

### **DIRECT-CURRENT MOTOR WITH SCR POWER-SUPPLY DRIVES**

General industries use many dc motors with SCR power supplies. These drives perform very well in the exacting circumstances they normally face. Some of these drives are used to drive pumps. They are configured as shown in Figure 14 and consist of a dc shunt wound motor and an SCR power supply.

The dc power supply unit rectifies motor bus voltage to an adjustable dc voltage level, which in turn energizes the armature of the motor. The second function of the power supply unit is to rectify motor bus voltage and apply this constant dc voltage to the motor shunt field. By adjusting the dc voltage to the motor armature, the speed of the motor can be adjusted to a desired value.

The SCR power supply unit consists primarily of a short-circuit protective device, a switching contactor, SCR power modules, firing circuitry, a speed regulator, and a shunt field rectifier. The firing circuitry responds to a low-energy-level speed potentiometer or some process variable. The SCRs in turn respond to the firing circuitry and translate those signals into the correct dc voltage to be applied to the armature of the motor. Control circuitry is included to monitor motor current and limit it to a preselected value, such as 150% of normal.

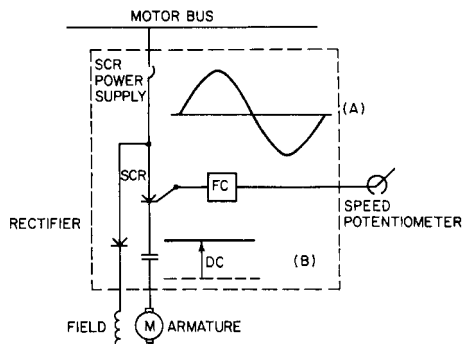
The SCR power supply unit comes packaged for easy installation in the field.

Speed-torque curves for the drive and for a representative centrifugal pump are shown in Figure 15. The steepness of the motor torque provides a clue to its stiffness; that is, its ability to resist speed change because of a change in load torque. Motor torques are limited to some ceiling, such as 150% of normal, by the current limit circuitry of the drive. Table 6 provides significant data useful for drive selection.

### **DRIVE COMPARISONS**

When comparing drives, factors to be considered include the following:

- *Drive costs—both initial and operating cost.* Cost considerations must include not only initial (installed) cost but also drive efficiency and power factor effects. Power factor may



**FIGURE 14** Block diagram for dc motor with SCR power supply

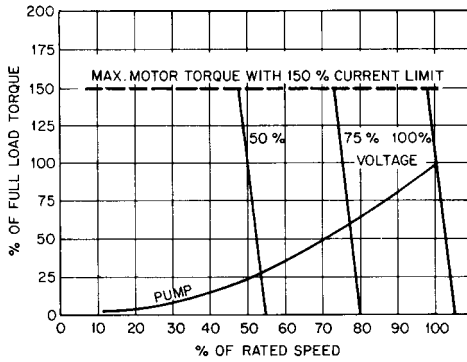


FIGURE 15 Torque versus speed for dc motor with SCR power supply

TABLE 6 Direct-current motor with SCR power-supply drive data

Drive element	Power rating <sup>a</sup>	Voltage rating	Max rated speed, rpm	Speed range, %	Enclosure	Mounting	No. of speed points
Motor	Open horizontal machines can be built at least up to 1500 hp (1120 kW); see Enclosure for other limits	240 500 550	Rating increases inversely with power rating; can match almost all pump speed requirements	At least 95	Vertical: open/dripproof, upthrough 300 hp, (224 kW) totally enclosed up through 200 hp (149 kW) Horizontal: open/dripproof, totally enclosed up through 200 hp (149 kW)	Vert. or horiz.	Infinite
SCR power supply	Can be built at least up to 1500 hp (1120 kW)	Any NEMA ac input voltage; will match motor voltage	...	At least 95	NEMA 1; NEMA 12	Floor	Infinite

<sup>a</sup>Drive can power either constant-torque loads or those varying as the square of the speed.

be of critical importance in influencing total costs highly dependent on the terms of the rate structure applied by the power supplier.

- *Operating characteristics.* All the drives discussed in this section compare favorably and all are considered generally suitable to perform functionally as pump drives.
- *Mechanical features* include enclosure, mounting, bearing capabilities, and arrangement (horizontal, vertical). Features are highly application related.
- *Mechanical simplicity* is one of most importance to operations personnel. It can consist of the number of wear points (parts) in rotating and control equipment. The rationale is

based on the concept that parts subject to wear are the eventual causes of failure; the smaller the number of parts, the less cause for failure.

- *Heat emission—removal requirements* can be critical depending on where the equipment is to be located. Heat can be emitted by both the equipment and the drive. If they are located in an enclosed area or building, heat emission can be an important issue.

In the final analysis, no simple routine can be suggested for drive selection. Each drive must be reviewed in the light of the application and its requirements. By reviewing the capabilities and features of the various drives, one has a starting point leading to successful drive selection.

The relative importance of these factors seldom remains stable but changes as application circumstances change.

# 6.2.3 FLUID COUPLINGS

CONRAD L. ARNOLD

## **TYPES OF FLUID COUPLINGS**

---

The term *fluid coupling* can be loosely used to describe any device utilizing a fluid to transmit power. The fluid is invariably a natural or synthetic oil because oil is capable of transmitting power, is a lubricant, and is able to absorb and dissipate heat. Manufacturers have tried water as the fluid in fluid couplings, but sealing problems (keeping water out of the bearings and oil out of the water) and corrosion have prevented its use in any standard catalog drive.

All fluid couplings may be broken down in four categories:

1. Hydrokinetic
2. Hydrodynamic
3. Hydroviscous
4. Hydrostatic

## **HYDROKINETIC DRIVES**

---

Although all types of fluid couplings are used in starting and controlling pumps, the one most commonly used is the hydrokinetic machine (Figure 1).

**Basic Principle** In the hydrokinetic drive, commonly known as a fluid drive or hydraulic coupling, oil fluid particles are accelerated in the impeller (driving member) and then decelerated as they impinge on the blades of the runner (driven member). Thus, power is delivered in accordance with the basic law of kinetic energy:

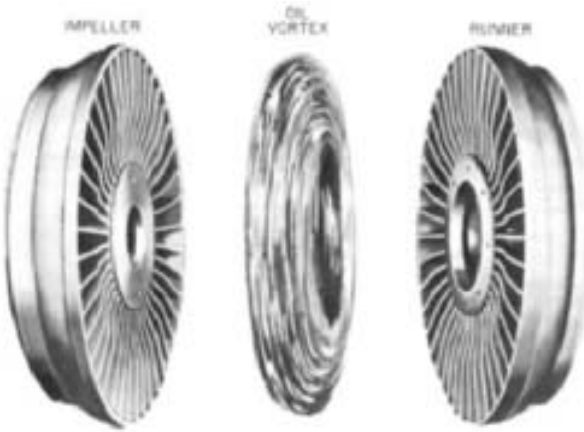


FIGURE 1 Power-transmitting elements of a hydrokinetic coupling (American Davidson)

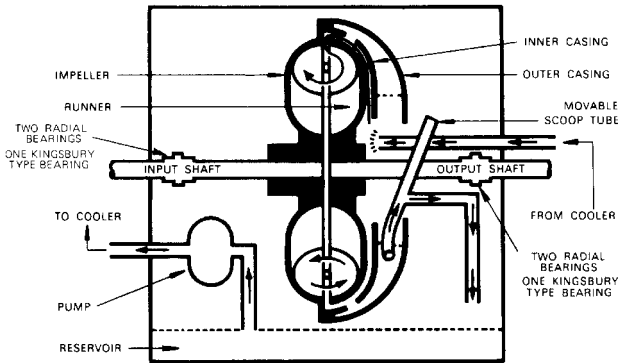


FIGURE 2 Hydrokinetic coupling, scoop-trimming type (American Davidson)

$$E = \frac{1}{2}M(V_1^2 - V_2^2)$$

where  $F$  represents energy,  $M$  is the mass of the working fluid,  $V$  is the velocity of the oil particles before impingement, and  $V^2$  is the velocity after impingement on the runner blades.

This principle is used in traction units and, with modification, in torque converters. Neither of these offers controlled variable speed.

In variable-speed units, the mass of the working fluid can be changed while the machine is operating and infinitely variable output speed is achieved. Variation of oil quantity can be accomplished in four ways: scoop-trimming couplings, leakoff couplings, scoop-control couplings, and put-and-take couplings (Figures 2 to 5).

**Components** The following components are common to all the above types with few exceptions.

The housing of the fluid drive serves four purposes—as a reservoir for the nonworking oil, as a support for the bearings and scoop tube, as a guard to surround the moving parts, and as a container for oil particles and vapors that prevents their escape to the atmos-

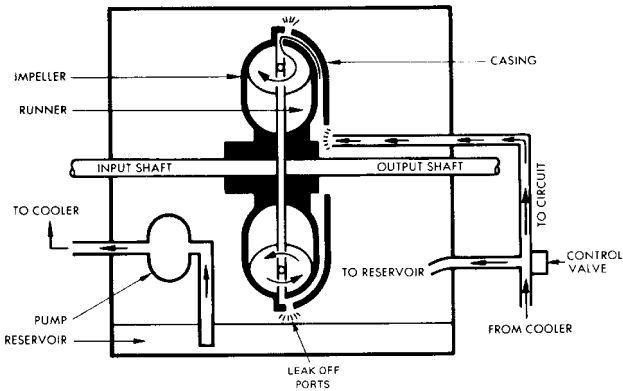


FIGURE 3 Hydrokinetic coupling, leakoff type (American Davidson)

phere. It also supports the oil pump when an internal pump is used. On small units, the housing is of end-bell construction; all others are split on the horizontal centerline to facilitate inspection and maintenance.

Bearings are used to support the shafts radially and axially. In the case of smaller industrial units, ball or roller bearings are usually used; larger machinery utilizes babbitt radial bearings and Kingsbury thrust bearings. Input sleeve bearing pillow blocks often support the internal oil pump driving and driven gears. In most cases, the thrust bearings are designed to handle only the internal thrust of the fluid drive. Thrust developed by sleeve bearing driving motors can be accepted by the hydraulic couplings, but driven machines must usually have provisions to absorb their own thrust.

*Shafts* support the rotors and transmit driving torque to and from them. In some cases, shafts are hollow and are used to supply oil to the bearings and to the working circuit (Figures 2 to 5).

*Rotors* are often compared to halves of grapefruit after the meat has been removed and may be fabricated in three ways. The lightest-duty units are equipped with die-cast rotors of SAE 356 aluminum. Heavier-duty units have rotors that are machined out of 4130 or 4340 aircraft-quality steel forgings.

Inner and outer *casings* are bowl-shaped members that bolt to the front of the impeller to contain the oil in two connected areas known as the *working circuit* (Figure 2). One chamber is formed by the impeller and inner casings. The other is formed between the inner and outer casings and can be called the scoop-tube chamber. Ports in the inner casing permit oil to flow from one chamber to the other.

The *scoop tube* (Figure 2) can be moved radially or rotated inside the scoop tube chamber and is supported by sleeve or antifriction bearings. The pickup end of the tube is between the two casings facing the direction of oil rotation. Linkages permit the tube to be moved from outside the housing, and seals prevent the leakage of oil or vapors at this penetration.

An *oil pump* is provided that may be an internally mounted gear pump driven from the input shaft or an externally mounted positive displacement motor-driven pump. In cases where extreme reliability is required, emergency standby ac- or dc-driven pumps may be furnished. These pumps furnish light turbine oil to lubricate, transmit power, and remove heat from the fluid drive. In many cases, they supply lubrication to the driver, the intermediate gear boxes, and the driven machine.

*Oil coolers* are required on all drives rated above 3 hp (2.2 kw). These coolers remove heat dissipated by the fluid drive and other machines for which they furnish lubrication. Shell-and-tube water-to-oil exchangers are normally supplied, although finned-tube air-to-oil exchangers are utilized where water is not available or economical. On pipeline work, it is common to use in-line coolers. The product of the pipeline is put through one side of the cooler to remove heat from the fluid-drive oil system.

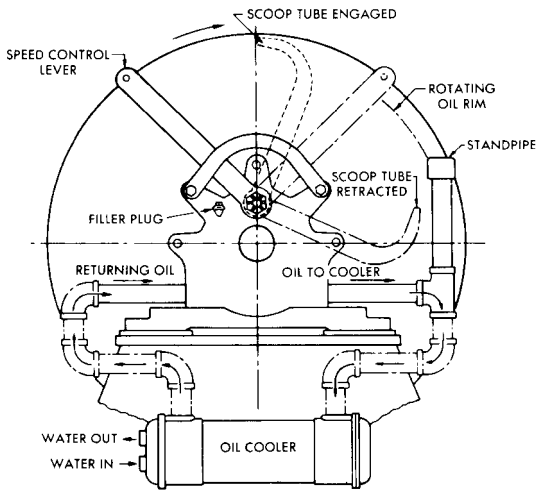
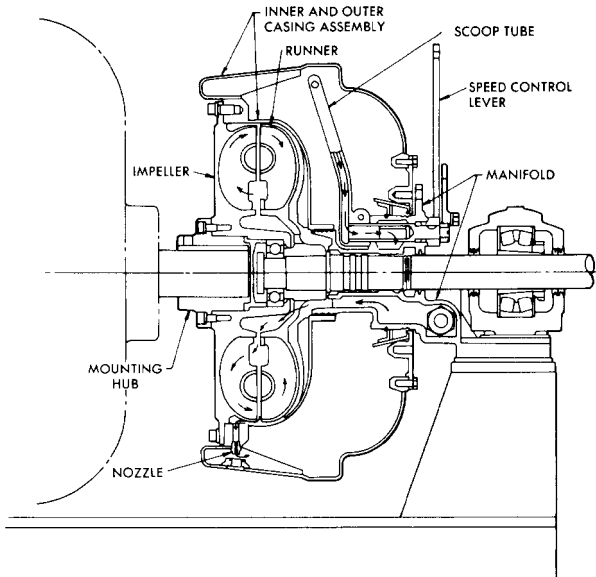


FIGURE 4 Hydrokinetic coupling, scoop-control type

*Manifolds* are usually used on scoop-controlled couplings in lieu of housings. They provide passages to permit oil flow to and from the working circuit and support the scoop tube and, sometimes, one bearing on the output shaft.

**Operation** The flow of oil in the *scoop-trimming* fluid drive is begun by the circulating pump, which is driven at constant speed by the input shaft, or external motor driver. The circulating pump moves the oil from the reservoir at the bottom of the housing to an external oil cooler (if used) and then to the rotating elements. Oil entering the rotating casing is acted upon by centrifugal force caused by the casings rotating at the input speed. This

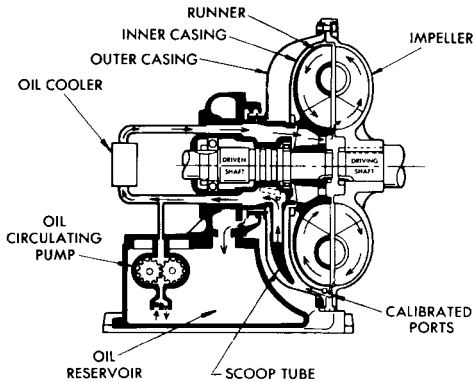


FIGURE 5 Hydrokinetic coupling, put-and-take type (American Davidson)

centrifugal force throws the oil outward against the side of the casing and into the impeller and runner, or working circuit, where it takes the form of an annular ring. Communication ports in the inner casing permit the oil level to equalize in the two chambers.

The amount of oil in the working circuit is regulated by the scoop tube acting as a sliding weir. The scoop tube removes the oil from the casing and empties it into the oil reservoir at the bottom of the housing, where it is ready to begin the cycle once more.

By either manual or automatic control, the scoop tube is moved in the casing. This, in turn, sets the level of the oil in the working circuit because the oil tends to seek the same level in the entire assembly. The scoop tube is designed to give fast response for both increase and decrease of output speed as required. In the *leakoff* type of fluid drive (Figure 3), the scoop tube and outer casings are not used. Oil flow is initiated by a pump, usually of the viscous or centrifugal type, driven by the input shaft, through a heat exchanger (if required) and to a two-way control valve. This control valve modulates between the two extreme positions: all oil to the working circuit and all oil dumped back to the reservoir. Oil in the working circuit is thrown out through orifices called *leakoff ports*. Flow is created by centrifugal head, which varies with the depth of oil in the coupling.

If oil is added to the coupling faster than it is thrown out of the orifices, the quantity of oil in the unit and the output speed increase. Obviously the converse is true as well, and if oil is put into the working circuit at exactly the same rate that it is "leaked off," the unit runs at constant speed. This type of unit lends itself well to closed-loop automatic control, which compensates for the differential flow through the leakoff ports. Manual control is questionable because oil must be added at *exactly* the rate it is discharged or output speed will drift.

In the scoop-control fluid drive, the communication ports in the inner casing are closed to form orifices and the scoop tube casing is sealed at the shaft. This breaks the unit into two separate chambers, the working circuit between the impeller and inner casing and the rotating reservoir between the inner and outer casings. The two are connected only by the orifices, or leakoff ports. Usually the housing, three bearings, and input shaft are omitted. In this configuration, the input rotor and casings are supported by the driving motor. In some cases, the mounting is accomplished through a solid hub as shown in Figure 4, and in others through a disk capable of flexing to absorb slight misalignment. The runner and output shaft are supported either by a pilot bearing and an outboard bearing or by a pilot bearing and the driven machine through a piloted flexible coupling.

Oil flow is initiated by the scoop in the reservoir acting as a pump. This flow is directed out through the manifold to the oil cooler, back to the manifold, and into the working circuit.

A portion of the oil constantly flows through calibrated nozzles in the inner casing to the outer casing, where it is held in an annular ring against the outer casing by centrifugal force. The fluid drive is initially charged with just enough oil to fill the impeller and



runner and the cooler circuit so the idle oil in the outer casing is a subtraction from the working circuit. The movable scoop tube adjusts the oil quantity in the outer casing and thus regulates the oil quantity in the working circuit. The scoop tube can be fully engaged, where it skims off all the oil in the casing and thus fills the working circuit. Otherwise, it can be retracted completely so all the oil lies idle in the outer casing and the unit is "declutched." Intermediate positions regulate torque and speed of the drive.

*Put-and-take couplings* (Figure 5) have not been manufactured in recent years. There was, in the design of such couplings, a variation of the scoop control coupling wherein the position of the scoop tube was fixed; thus, the tube provided circulation only between working circuit and cooler. The amount of oil in the coupling itself was regulated by a gear-type pump that was operated in one direction to pump oil from a reservoir into a unit, stopped to maintain constant coupling speed, or reversed to remove oil from the drive and pump it into the reservoir. This created very unwieldy control systems having very poor response characteristics with some bunting, and the design became obsolete.

Reversibility can be obtained by reversing the driving motor, provided that the unit incorporates oil pumps that are not affected by input shaft rotations. In addition, units utilizing scoop tubes must have dual tips that can accept the flow of oil from either side.

In all fluid drives, the same fluid is utilized to transmit power, to remove absorbed heat, and to lubricate. Thus there is no requirement for internal seals, or slingers, and positive lubrication is assured. Because the power-transmitting medium is the heat-absorbing medium, there are no problems of heat transfer encountered in units utilizing oil pumps. This type of unit can be selected with the capability of dissipating 100% or more of the driving-motor rated power.

## HYDRODYNAMIC DRIVES

This type of fluid coupling is occasionally used to drive pumping equipment, usually in the portable pump field (Figure 6).

**Basic Principle** In the most common forms of hydrodynamic drives, planetary gear trains utilize some components as oil pumps. Throttling the discharge of these pumps creates back pressure and increases drive torque.

**Components** The input shaft, supported by a bearing either on an independent bearing pedestal or on a packaged subbase assembly, drives the housing, endplate, manifold, and planetary gear shafts. These planet gears are partially surrounded by the manifold, which forms a pump cavity. The sun gear drives the output shaft. The control yoke moves the internal valve.

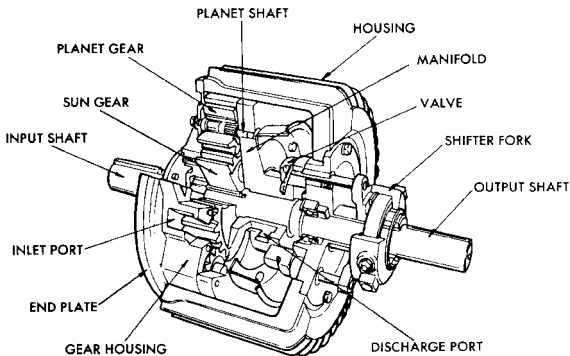


FIGURE 6 Hydrodynamic coupling (American Davidson)

**Operation** When the driver is started, oil flow is initiated by planet gears rotating against the sun gear. With the control yoke in the low-speed position, the mixing valve is positioned to admit air mixed with oil, the pump discharge valve ports are wide open, and the pump-developed head is approaching zero. The force on the pump gear teeth approaches zero, and the output speed is minimum. As the control yoke is moved, the pump discharge valves begin to close, less air is admitted, and the discharge pressure rises. This develops resistance to pump rotation and imparts a force on the sun gear, and the output shaft begins to rotate. If the oil discharge ports are closed, theoretically the pump pressure will rise until the pump gear is locked to the sun gear. This would rotate the output shaft at exactly input speed. In practice, leakage permits the pump to rotate and the output shaft turns at a slightly lower speed than the input shaft. Reversibility can be achieved simply by reversing the driving motor.

## HYDROVISCIOUS DRIVES

Hydroviscous drives are relatively new in commercial use. There are several manufacturers in the United States who are marketing this type of drive for a wide range of pump applications (Figure 7).

**Basic Principle** Hydroviscous drives operate on the basic principle that oil has viscosity and energy is required to shear it. More energy is required to shear a thin film than a thick one. The hydroviscous drive varies its torque capability by varying the film thickness between driving and driven members.

**Components** The following components are common to all hydroviscous drives. The primary variations from one manufacturer to another are in the mechanics of control, the numbers of disks, and the support of the rotors.

The *housing* serves the same purpose as in other fluid drives, supporting bearings, guarding moving parts, and containing oil and vapors. In addition, one manufacturer uses

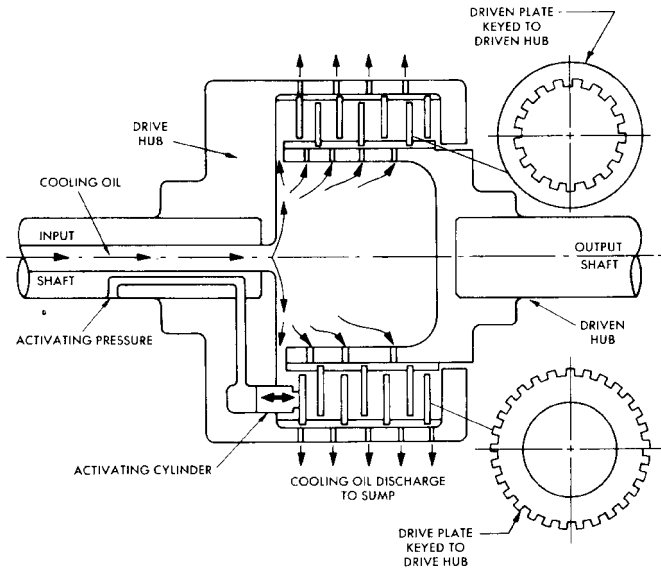


FIGURE 7 Hydroviscous coupling (American Davidson)

cored passages in the housing to introduce water to remove heat from the working fluid. Bearings are usually of the antifriction type in small machines, with sleeve and Kingsbury bearings available in large units. Shafts support rotors, transmit driving torque, and, in most cases, are hollow to supply cooling oil and control oil.

The *rotors* have the driving hub keyed on the inside to driving disks and the driven hub keyed at its inner diameter to the driven disks.

The *disks* are made of various materials and are usually grooved with some type of pattern to direct cooling oil flow.

*Pistons* are hydraulic. When moved by control hydraulic oil, they force the disk stack closer together.

*Oil pumps* are usually motor-driven, but sometimes are driven by the input shaft of the coupling. It is not uncommon to have two separate pumping systems, one providing high-pressure control oil and the other lower-pressure cooling oil.

*Oil coolers* are usually shell-and-tube water-to-oil heat exchangers, although air-to-oil exchangers can be furnished and, as mentioned earlier, cored housings can sometimes be used.

**Operation** Oil flow is initiated by the oil pumps, which force cooling oil through the disk stack, draining into the sump. With the control set at minimum speed, the disks are at maximum spacing and the coupling transmits minimum torque. As pressure is applied to the piston, the disks are forced together. This decrease in film thickness between disks increases the force transmitted from one plate to the next. At maximum piston pressure, the spacing between plates is zero and the output shaft is driven at input shaft speed. In the full-speed condition, this device is actually a lockup mechanical clutch; at reduced speeds, it is an oil shear coupling; and in a narrow band between these two points of operation, it must be looked upon as an oil-cooled mechanical clutch. Reversibility can be accomplished by reversing the driving motor if oil pumps are driven by separate motors.

---

## HYDROSTATIC DRIVES

**Basic Principle** There are many variations of hydrostatic variable-speed drives, but in one form or another they invariably use positive displacement hydraulic pumps in conjunction with positive displacement hydraulic motors.

In some cases, varying amounts of fluid are bypassed from the pump discharge back to the pump suction. This provides a controllable variable flow to the positive displacement motor and therefore a variable output speed. This system has no particular advantages over the more common variable-speed drives. The higher-than-average first costs and above-average maintenance required explain why this type of hydrostatic system is seldom used.

In other cases, the hydrostatic drive system uses variable-flow positive displacement pumps that may be of the sliding vane type or axial piston type (Figure 8). Reducing the discharge flow on the hydraulic pump reduces output speed; increasing pump flow increases output speed. This type of variable-speed drive is offered in package form with pump, piping, and motor mounted in a common housing. It offers the capability of torque multiplication, maintains a relatively constant efficiency regardless of speed, has excellent control characteristics, and is widely used in the machine tool and other industries. The output shaft can be reversed by valving (without changing motor rotation). This design has inherently high first cost and maintenance requirements, precluding significant use as a pump driver.

---

## CAPACITY

**Hydrokinetic Drive** Being centrifugal machines, fluid drives follow very familiar laws: power varies as speed raised to the third power (Figure 9), as diameter to the second power, and directly as the density of the working fluid.

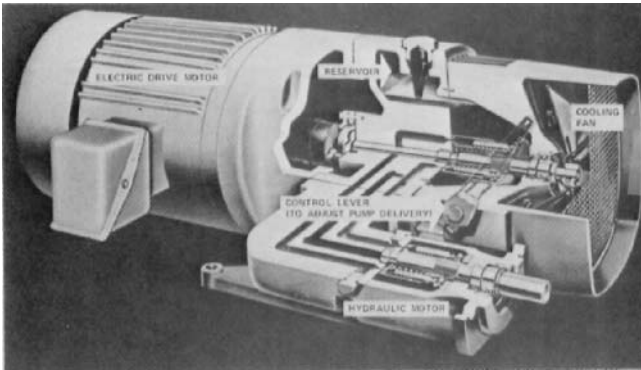


FIGURE 8 Typical package hydrostatic drive (Sperry Vickers)

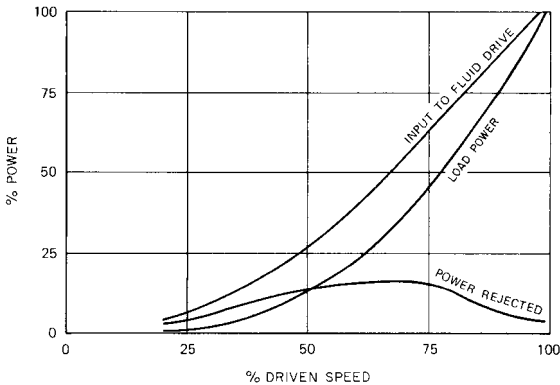


FIGURE 9 Load power varies as speed cubed. This figure represents a pump operating in a system where all the head is frictional, or where head varies as flow squared. In this system, the driven pump operates at only one point on its characteristic curve, and therefore the shape of the pump curve is academic. Although the rapid loss of hydraulic coupling efficiency at reduced speeds is quite obvious, the dramatic decrease in pump power requirements results in a total system power that is most acceptable. Note that the heat rejection requirements in the fluid drive are maximum at about 18% of the total load power.

Thus hydraulic capacity is governed by speed, diameter, and operating fluid; mechanical capability is governed by the structural design of housing, bearings, shafts, rotors, and casings; thermal capacity is limited by the capacity of the oil pumps, the specific heat and thermal conductivity of the oil, and the ability of the heat exchanger to dissipate heat.

It should be noted that in scoop-trimming couplings, the oil pumps are usually sized solely for heat dissipation. In the leakoff coupling, the orifices are sized to permit enough oil flow to dissipate heat, and the pumps must handle this plus enough to fill the coupling in a reasonable time. The scoop-control coupling has limited flow and pressure because both are generated by the scoop tube. This may preclude its uses in certain positive displacement pumping applications or where installation of coolers at a remote location is required.

**Hydrodynamic Drive** This type of coupling varies so much in configuration that it is impossible to establish similar laws. Because any given machine has a definable torque limitation, we can state that power varies directly with speed.

Because standard units have no provision for removal and replacement of the working fluid, all cooling must be provided on the exterior surfaces of the rotating housing. This becomes a decided limitation if the unit is to be used with constant-torque loads and has limited the available sizes to some degree.

**Hydroviscous Drive** As would be expected, this device also follows the centrifugal laws: power varies as speed raised to the third power and as diameter raised to the second. However, the density of the working fluid has little or no effect; instead, capacity varies directly with viscosity. Thus, hydraulic capacity varies with speed, diameter, and viscosity. Mechanical capability is a relatively simple matter of structural design. However, thermal design is critical. Because power-transmitting capability varies with viscosity, which in turn varies with temperature, disk design is most important. Free area available for cooling oil flow varies with disk spacing, output speed, and heat load.

## REGULATION

---

The output speed of all fluid couplings (hydrostatic drives are not being considered) is affected, to some degree, by changes in load. Although this may be significant in cases of single-cylinder, low-speed reciprocating pumps, it is insignificant on multicylinder reciprocating and all centrifugal pumps. In these cases, 1% speed regulation is considered normal. In special cases, regulation has been guaranteed at 0.3%.

## TURNDOWN

---

Standard catalog hydrokinetic and hydroviscous units offer the regulation described above over a 5-to-1 turndown on centrifugal machines and 4-to-1 turndown when driving positive displacement pumps on constant-pressure systems. Specially designed fluid drives have been sold that give stable control at 10-to-1 turndown. Hydrodynamic units are limited primarily by heat dissipation capabilities and range from turndown values of 100 to 1 to 1.2 to 1.

Figure 10 is typical of a boiler-feed pump where a high percentage of the developed head is relatively constant. In this case, this fixed head is the boiler pressure. The figure demonstrates the savings in pressure and power realized when this system is used rather than a feedwater regulating valve.

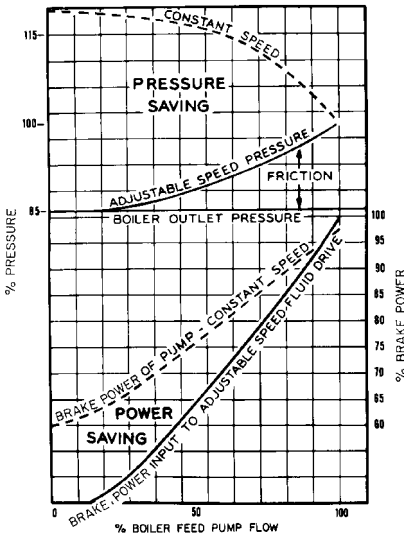
Figure 11 assumes that a positive displacement pump is working on a system where pressure is constant. Although this type of system is seldom found, it is shown here to demonstrate that the rapid reduction in fluid drive efficiency does not require overmotoring the pump. Although system efficiency is much poorer than that of a bypass valve, fluid drives are used to provide no-load starting, isolation of torsional vibrations in reciprocating pumps, and elimination of the bypass valve in slurry systems where erosion is severe.

**Response** It must be recognized that all fluid couplings being discussed here are slip devices. Thus, any demand speed change cannot be accomplished in microseconds or milliseconds. However, the time required to change the torque applied varies from one type of unit to another.

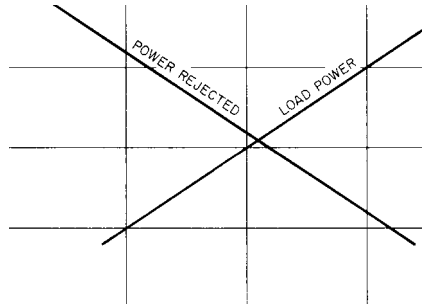
**Hydrokinetic Drive** In the scoop-trimming fluid drive, response speed is affected by many factors. The speed with which oil can be added to the working circuit (a factor of the size of the oil pumps) or removed from it (a factor of the size of the scoop tube) influences response capability.

In the leakoff unit, the size of the leakoff ports determines how quickly the unit will empty. However, the oil pumps must be sized to replace this oil and have additional capacity to fill the coupling in a reasonably short time.

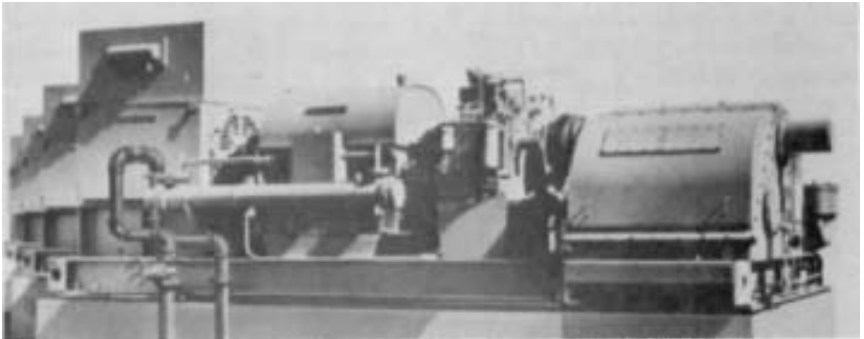
Scoop-control units are limited by the ability of the scoop tube to pump oil from the reservoir into the working circuit and by the ability of the leakoff ports to return it to the



**FIGURE 10** Comparison of adjustable-speed and constant-speed pressure and power characteristics for a typical centrifugal boiler-feed pump



**FIGURE 11** Positive displacement pump with constant discharge head



**FIGURE 12** Thirteen fluid drives driving reciprocating pumps on a coal pipeline. The fluid drive absorbs a large percentage of the pulsations created by the reciprocating pumps and controls their speed to provide proper pipeline flow (American Davidson).

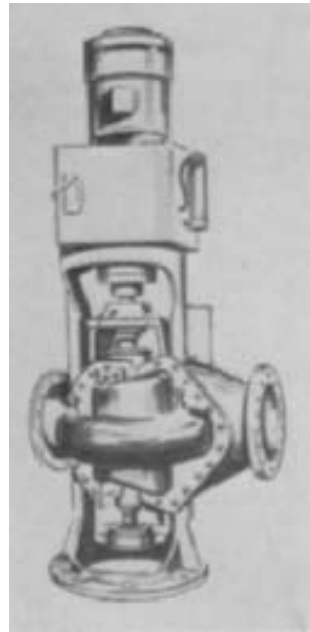
reservoir. Some special marine couplings utilize quick-dumping valves, but these are seldom, if ever, used with pump drives.

Obviously the speed at which the scoop tube is moved is also significant. Large polar moments of inertia ( $WK^2$  values) of the driven equipment will increase response time.

The scoop-trimming coupling offers the best overall response characteristics of the hydrokinetic drives, and standard catalog machines have normal fill times ranging from 10 to 15 s. They will accomplish 90% of a 10% step speed change in the 40 to 100% speed



**FIGURE 13** Cutaway view of vertical fluid drive suitable for operation with vertical pumps. Note the NEMA P pump flange and output shaft (American Davidson)



**FIGURE 14** Fluid drive of Figure 13 mounted on a vertical-shaft pump (American Davidson)

range in 7 to 20 s if coupled to a “normal load inertia.” Special units are in operation where this change is accomplished in 2 to 6 s.

**Hydrodynamic and Hydroviscous Drive** Both hydrodynamic and hydroviscous couplings respond very quickly to a change in demand for torque output. Both require a mechanical motion (change in valve position or change in spacing between disks) followed immediately by a change in pressure or in film thickness.

In most cases, the torque available for speed change and the  $WK^2$  values involved are of such a magnitude that the major portion of the response time is caused by inertial effects rather than by the time required to change torque. This is particularly true in the deceleration of centrifugal pumps. Unless auxiliary brakes are built-in, none of the hydrokinetic, hydrodynamic, or hydroviscous drives can provide dynamic braking. On a demand to decrease speed, they can at best reduce driving torque to zero. Under these circumstances, the only retarding force to slow the inertia of the driven machine is the load it developed. In the case of centrifugal pumps on fixed systems, this load would fall off as the cube of speed, and below 40% of full speed, such pumps have an almost insignificant braking effect.

## **EFFICIENCY**

---

There are two kinds of losses present in hydrokinetic, hydrodynamic, and hydroviscous couplings. First, we will consider what are termed circulation losses. They are made up of

bearing friction, windage, and the power required to accelerate the oil in the rotor. On internal pump units, the power required to drive the oil pump is included. As an average, these losses represent approximately 1.5% of the unit rating, and for most purposes these losses may be considered as being constant, regardless of output speed.

Second are *slip losses*. As is the case on similar slip machines such as mechanical clutches and eddy-current couplings, the torque on the input shaft equals the torque on the output shaft. Therefore any reduction in the speed of the output shaft has a directly related power loss inside the machine. In other words,

$$\text{Slip efficiency} = \frac{\text{output speed}}{\text{input speed}} \times 100$$

The total fluid drive losses are the sum of the two inefficiencies. The complete energy formula is

In USCS units

$$\text{Fluid drive input horsepower} = \frac{\text{output horsepower}}{\text{output speed/input speed}} + \left( \begin{array}{l} \text{circulation horse-} \\ \text{power losses} \end{array} \right)$$

In SI units

$$\text{Fluid drive input kilowatts} = \frac{\text{output kilowatts}}{\text{output speed/input speed}} + \left( \begin{array}{l} \text{circulation} \\ \text{kilowatt losses} \end{array} \right)$$

At maximum designed operating speed (which is usually about 98% of driven speed), the total coupling efficiency is approximately 96.5%, with 1.5% of the losses being circulation losses and 2% being slip losses. The hydroviscous unit can be operated at 100% driven speed, but under these conditions it is not a fluid coupling.

Because the circulation losses become relatively insignificant at reduced speeds, approximate calculations may be made using the formula

$$\text{Efficiency} = \frac{\text{output speed}}{\text{input speed}}$$

## CONTROLLERS

---

Of the hydrokinetic devices, the scoop-trimming and scoop-control units require that a mechanical motion be imparted to the scoop tubes for control, and some device must be furnished to provide this motion. This may be a hand crank on a manual control system. Simple mechanical systems are often used—a typical example is a weighted float with a rope connected to the scoop tube, controlling level in a tank. However, most installations utilize electric, electrohydraulic, hydraulic, or pneumatic actuating devices. It is not surprising that the pipeline and refinery industries use electrohydraulic actuators similar to those used on valves. The electric utility industry prefers pneumatic or electric damper operators. The only criterion for actuator selection is compatibility with the other elements of the control system.

The leakoff devices require a signal to the control valve. At present, this is standardized as a hydraulic-pressure signal, although special transducers would permit the use of other types of signals. The hydrodynamic devices are available with manual level control (which could be adapted to actuators) or with closed-loop constant-pressure or constant-temperature systems. All hydroviscous drives utilize oil pressure applied to a piston to “clamp” or vary the spacing of the disks. This hydraulic pressure may be varied by almost any type of signal, provided that the proper servos are utilized. Thus the signal may be electric, hydraulic, or pneumatic.



## CAPACITIES AVAILABLE

Standard catalog variable-speed fluid couplings are available from one or more manufacturers in the speeds and powers shown in Table 1. Special designs are available for higher power ratings.

## DIMENSIONS

To give some idea of physical dimensions, Table 2 lists approximate dimensions for hydrokinetic drives of one U.S. manufacturer. These feature a scoop-trimming coupling and are probably the largest unit for a given speed and power.

## SELECTION AND PRICING

Because of variations in fluid coupling design for different sizes and speeds, it is virtually impossible to develop rule-of-thumb methods of estimating costs. The price list of one major fluid drive manufacturer indicates that prices can range from \$60 per horsepower for sophisticated machines down to \$25 per horsepower for others (in 1984 dollars). Fluid couplings prices can be increased dramatically by specific requirements for exotic controls, backup pumps and heat exchanger equipment, and other accessories. Because of this fact, it is recommended that the manufacturers be contacted to obtain even budget prices.

**TABLE 1** Variable-speed coupling capacities

Hydrokinetic				
Input speed, rpm	Min/max input hp for horizontal-shaft units <sup>a</sup>	Max input hp for vertical-shaft units <sup>a</sup>	Hydrodynamic min/max input hp <sup>b</sup>	Hydroviscous min/max input hp <sup>b</sup>
720	40,000–45,000	....	....	3,000–8,000
900	1,000–7,500	6,000	1–25	3,000–10,000
1,200	1,000–14,000	17,000	1–30	3,000–15,000
1,800	1,000–14,000	18,000	1–60	3,000–20,000
3,600	1,000–30,000	29,000	....	3,000–20,000

<sup>a</sup>1 hp = 0.746kW

<sup>b</sup>Horsepowers apply to either horizontal or vertical units.

**TABLE 2** Hydrokinetic drive dimensions

Power at 1800 rpm, input hp (kW)	Length, in (cm)	Width, in (cm)	Shaft height, in (cm)
5 (3.73)	24 (61.0)	15 (38.1)	11½ (29.2)
20 (14.9)	39 (99.1)	18 (45.7)	12½ (31.7)
50 (37.3)	38 (96.5)	28 (71.1)	19 (48.3)
100 (74.6)	38 (96.5)	28 (71.1)	19 (48.3)
1000 (746)	74 (188)	50 (127)	30 (76.2)
4000 (29811)	102 (259)	62 (157)	42 (107)

The basic information required by the manufacturer for selection and pricing is as follows:

1. Speed and type of driver
2. Power required by the driven machine at, or at least, one operating point
3. Character of driven machine—smooth or pulsating load; how torque requirements change with speed
4. Cooling medium available and temperature of medium
5. Control type
6. Accessories
7. Special specification requirements

Reasonable budget figures can usually be obtained with items 1 to 3 only.

## **CONCLUSION**

---

Fluid couplings are utilized to drive pumps in virtually all pump applications requiring variable flow or pressure. They are used primarily to improve efficiency and controllability, to permit no-load starting, and to reduce pump and system wear. They are standardized to the degree that units are available to handle most pumping applications. Most manufacturers stand ready to develop new designs as the requirements of the marketplace change.

# 6.2.4 GEARS

H. O. KRON  
F. L. VAN LANINGHAM

## **USE OF GEARS WITH PUMP DRIVES**

---

The main use of gearing in pump drives is to reduce the speed of the prime mover (a motor or an engine) to the level applicable to the pump. In some cases, however, the gears are employed to step up the speed because the pump must operate at a speed higher than that of the prime mover.

There are other jobs that gear drives must perform with pump units. For instance, a vertical pump may be combined with a prime mover that must operate horizontally (as in the case of a diesel engine). A right-angle gear set (Figures 1 and 4) can be incorporated into the drive of such a combination to transmit the power “around the corner” even if the gears are of a 1:1 ratio and no speed change is involved. See a word of caution concerning even ratio gears, “Minimizing Gear Noise,” item 9.

At times, too, a gear drive must combine the power shafts of two prime movers; for example, an electric motor and a diesel engine. This combination is desirable where there is a need for emergency power in cases of electric power failure. The motor is used ordinarily and the diesel is reserved for emergencies. In such an arrangement, the motor may be mounted vertically on top of the gear drive to drive right through the shaft, whereas the diesel is geared at right angles to the motor.

Gear drives are also used to vary the speed of a pump. Change gear arrangements (Figure 2) may be used to vary the gear ratio. Also, numerous types of variable-speed devices, such as variable-speed pulley belts, friction rollers, hydraulic couplings, hydrostatic and hydroviscous drives, eddy-current and electric drives, are often utilized.

## **TYPES OF GEARS**

---

The gears generally used for pump applications are parallel-shaft helical or herringbone gears and right-angle spiral-bevel gears. Spur gears are used on occasion, particularly in



**FIGURE 1** Spiral-bevel gear, right-angle vertical pump drive



**FIGURE 2** Four-speed change gear, variable-speed drive

low-power, low-speed pump drives. Straight bevel and hypoid gears are also occasionally used in right-angle drives. As in the case of spur gears, straight-bevel gears are limited in power and speed. Hypoid gears are employed only infrequently for pumps because they are generally more costly than the other right-angle types. Worm gears, too, are employed only on occasion, in cases where an overall package requires a compact gear arrangement or when a high ratio of speeds is called for. Worm gears are limited in power capacity, and the efficiency of this type of drive is lower than that of other types. Figure 3 shows the various types of gears.

**Parallel-Shaft Gearing** A high-speed parallel-shaft gear drive is shown in Figure 5.

**HELICAL VERSUS SPUR GEARS** Spur gears transmit power between parallel shafts without end thrust. They are simple and economical to manufacture and do not require thrust bearings, but they are generally used only on moderate-speed drives.

One of the first decisions that must be made when considering a parallel-shaft gear reducer or power transmission drive is whether the gears should be spur or helical and, if helical, whether they should be single or double. It is generally acknowledged that helical gears offer better performance characteristics than do spur gears, but because helical gears, size for size, often are somewhat more expensive, some users have shied away from them to keep the cost of the gear drive to a minimum. However, cost studies that compared similar size spur and helical gears found that helical gears are actually a better buy.

The geometries of spur and helical gears are both the involute tooth form. Slice a helical gear at right angles to its shaft axis and you have the typical spur gear profile. Typical of a spur gear, however, is that, when driving another spur, its teeth make contact with the teeth of the mating gear along the full length of the face. The load is transferred in sequence from tooth to tooth.

A more gradual contact between mating gears is obtained by slanting the teeth in a way to form helices that make a constant angle—a helix angle with the shaft axis. Tooth contact between the teeth of mating helical gears is gradual, starting at one end and moving along the teeth so, at any instant, the line of contact runs diagonally across the teeth.

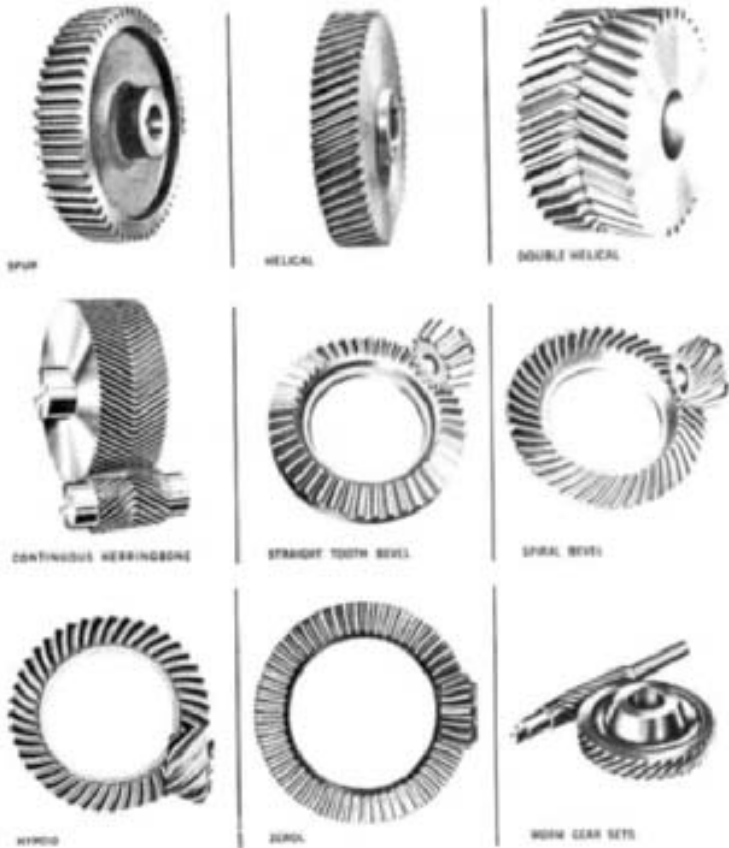


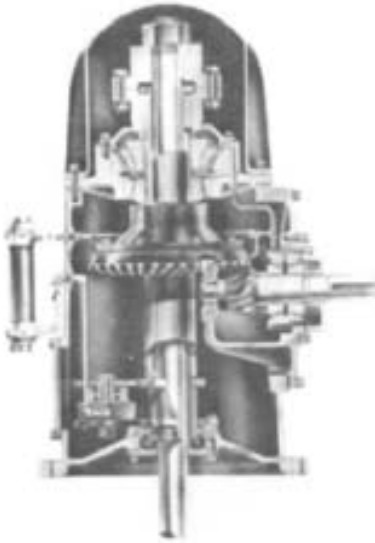
FIGURE 3 Types of gears

The effect of the tooth helix is to give multiple tooth contact at any time. Gear geometry can be arranged to give from two to six or more teeth at any time.

Because of the greater number of teeth in contact, a helical gear has a greater effective face width (up to 75% more) than an equivalent spur gear. Also, the effect of the tooth helix on the profile geometry in the plane of rotation is to make the pinion equivalent to a pinion with a greater number of teeth, thereby increasing its power capacity. A helical gear is capable of transmitting up to 100% more power than an equivalent spur gear. Furthermore, a helical gear set will give smoother, quieter operation.

The recommended upper limit of pitch line velocity for commercial spur gears is around 1000 ft/min (300 m/min). The upper limit for equivalent helical gears is about five times that, or 5000 ft/min (1500 m/min). Of course, as precision goes up, so do the permissible operating speeds for both spur and helical gears. Velocities in the 30,000-ft/min (9100-m/min) range are not uncommon for helical gears.

In addition to the normal radial loads produced by spur gears, helical gearing also produces an end thrust along the axis of rotation. The end thrust is a function of the helix angle: the larger the helix angle, the greater the thrust produced. Mounting assemblies and bearings for helical gearing must be designed to receive this thrust load.



**FIGURE 4** Cross section of spiral-bevel vertical pump drive



**FIGURE 5** High-speed parallel-shaft gear drive

**DOUBLE HELICAL GEARS** Gears of this type have two sets of opposed helical teeth. Each set of teeth has the same helix angle and pitch, but the helices have opposing hands of cut. Thus, the thrust loads in two sets of teeth counterbalance each other and no thrust is transmitted to shaft and bearings. Also, because end thrust is eliminated, it is possible to cut the teeth with greater helix angles than is generally used in helical gears. Tooth overlap is greater, producing a stronger and smoother tooth action.

The advantages attributed to helical gears are also applicable to double helical gears. Double helical gearing finds application in high-speed pump applications where a large helix angle must be combined with tooth sharing and elimination of end thrust for extremely smooth gear action.

Single helical gears, however, have some attractive advantages over double helical gears, the most significant being that, in the former, the external thrust loads do not affect gear tooth action. With a double helical gearing, a thrust load on the member with a thrust bearing tends to unload one of the helices and overload the opposite one. See transmission of external thrust forces in Section 6.3.1, "Pump Couplings and Intermediate Shafting."

Furthermore, the gear face for a single helical gear can be made narrower than for a double helical gear because the need for a groove between the two helices is eliminated. This leads to the use of a narrower, stiffer pinion with less tooth deflection and torsional windup and, generally, to a more favorable critical speed condition.

An axial vibration of the pinion, without a thrust bearing on a double helical gear set, is sometimes referred to as apex runout. This vibration can be caused by pitch circle runout where one helix is out of phase with the other. This tends to unload one helix cyclically and induce the vibration. The vibration will generally be the pinion because it has no thrust bearing, but it will be at the frequency of the member with the thrust runout problem.

When pitch circle runout, tooth spacing errors or lead errors are present in an element of a single helical gear set, the vibration will, when loaded, be radial because each member has a thrust bearing to restrain its axial movement.

**CONTINUOUS-TOOTH HERRINGBONE GEARS** Gears of this type are double helical gears cut without a groove separating the two rows of teeth. Because of the arched construction of

these gears, they are often known as “the gears with a backbone.” Continuous-tooth herringbone gears are used for the transmission of heavy loads at moderate speeds where continuous service is required, where shock and vibration are present, or where a high reduction ratio is necessary in a single train. Because of the absence of a groove between opposing teeth, a herringbone gear has greater active face width than the hobbled double helical gear and therefore is stronger. There is also no end thrust, as the opposing helices counterbalance one another. The bearing arrangement of herringbone gears is usually the same as double helix in that the pinion does not usually have a thrust bearing. See transmission of external forces under Section 6.3.1.

Much of the success of the continuous-tooth herringbone gear is due to the greater number of teeth in contact and to the continuity of tooth action, which is an outgrowth of the larger helix angle. These larger helix angles can be fully utilized without creating bearing thrust loads. Continuous-tooth herringbone gears normally are furnished with a helix angle of 30°. Herringbone gears are generally of a lower American Gear Manufacturers Association (AGMA) quality level than hobbled or ground gears.

### **Crossed-Axis Gearing**

**STRAIGHT-BEVEL GEARS** Gears of this type transmit power between two shafts usually at right angles to each other. However, shafts other than 90° can be used. The speed ratio between shafts can be decreased or increased by varying the number of teeth on pinion and gear. These gears are designed to operate at speeds up to 1000 ft/min (300 m/min) and are more economical than spiral-bevel gears for right-angle power transmission where operating conditions do not warrant the superior characteristics of spiral-bevel gearing. When shafts are at right angles and both shafts turn at the same speed, the two bevel gears can be alike and are called *miter gears*.

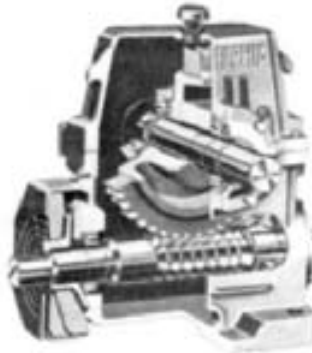
**SPIRAL-BEVEL GEARS** Spiral-bevel gear teeth and straight-bevel gear teeth are both cut on cones. They differ in that the cutters for straight-bevel teeth travel in a straight line, resulting in straight teeth, whereas the cutters for spiral-bevel gear teeth travel in the arc of a circle, resulting in teeth that are curved and are called spiral. Figure 4 shows a cross section of a spiral-bevel vertical pump drive.

Spiral-bevel gearing is superior to straight-bevel in that, in the former, loading is always distributed over two or more teeth in any given instant. Recommended maximum pitch line velocity for spiral bevels is about 8000 ft/min (2400 m/min). Spiral bevels are also smoother and quieter in action because the teeth mesh gradually. Because of the curved teeth, spiral-bevel pinions may be designed with fewer teeth than straight-bevel pinions of comparable size. Thrust loads are greater for spiral-bevel gearing than for straight-tooth bevels, however, and vary in axial direction with the direction of rotation and hand of cut of the pinion and gear. Where possible, the hand of spiral should be selected such that the pinion tends to move out of mesh. To assure that the pinion thrust is away from the cone center, out of mesh, the following applies:

<b>Driving Member</b>	<b>Hand of Spiral</b>	<b>Rotation Direction</b>
Pinion	Left Hand	CW
Pinion	Right Hand	CCW
Gear	Right Hand	CCW
Gear	Left Hand	CW

Reversing the direction of rotation should be avoided.

**ZEROL GEARS** Zerol-bevel gears are cut on conical gear blanks and have curved teeth similar to the spiral bevels, but the teeth are cut with a circular cutter that does not pass through the cone apex. Thus, these are spiral-bevel gears with zero spiral angle (hence the name). Furthermore, the tooth bearing is localized as in spiral-bevel gearing; thus stress concentration at the tips of the gear teeth is eliminated. Zerol-bevel gears are replacing straight-bevel gearing in many installations because their operation is



**FIGURE 6** Fan-cooled worm gear drive

smoother and quieter as a result of their curvature and their operating life is longer. Like straight-bevel gears, zero gears have the advantage of no inward axial thrust under any conditions. The zero spiral angle produces thrust loads equivalent to those in straight-bevel gears.

**HYPOID GEARS** Hypoid-bevel gears have the general appearance of spiral-bevel gears but differ in that the shafts supporting the gears are not intersecting. The pinion shaft is offset to pass the gear shaft. The pinion and gear are cut on a hyperboloid of revolution, the name being shortened to *hypoid*. Hypoid gears can be made to provide higher ratios than spiral-bevel gears. They are also stronger and operate even more smoothly and quietly. The fact that two supporting shafts can pass each other, with bearings mounted on opposite sides of the gear, provides the ultimate rigidity in mounting.

**WORM GEARS** In operation, the teeth on the worm of a worm gear set (Figure 6) slide against the gear teeth and at the same time produce a rolling action similar to that of a rack against a spur constant output speed completely free of pulsations. Worm gearing is particularly adaptable to service where heavy shock loading is encountered.

Worm gearing is extremely compact, considering load-carrying capacity. Much higher reduction ratios can be attained through a worm gear set on a given center distance than through any other type of gearing. Thus, the number of moving parts in a speed-reduction set is reduced to the absolute minimum. However, worm gearing is limited in power capacity and has lower efficiencies than parallel-shaft and bevel-gear types. Extremely high worm thrust loads are generated by worm gearing. Therefore, never reverse the rotation unless the unit is specifically designed for operation in both directions.

## **GEAR MATERIALS AND HEAT TREATMENT**

---

Two of the most important factors in dictating the success or failure of a gear set are the choice of material and heat treatment. This is especially true for gears designed for higher power. American Gear Manufacturers Association (AGMA) ratings for gear strength and durability are dependent on the choice of material and heat treatment. It is often possible to reduce the size of the gear box substantially by simply changing from low-hardened or medium-hardened gears (about 300 Brinell) to full-hardened gears (about 55 to 60 Rockwell C). Generally used methods for hardening gear sets are

1. Through hardening
2. Nitriding



3. Induction hardening
4. Carburizing and hardening
5. Flame hardening

The use of high-hardness, heat-treated steels permits smaller gears for given loads. Also, hardening can increase service life up to 10 times without increasing size or weight. After hardening, however, the gear must have at least the accuracy associated with softer gears and, for maximum service life, even greater precision. Furthermore, carburizing and ground gears must be aligned within their housings to a higher degree of accuracy than through-hardened gears. This is because their ability to “comply with” misalignment is less, although they are capable of transmitting much higher loads and longer life when properly aligned.

**Through Hardening** Suitable steels for medium to deep hardening are 4140 and 4340. These steels, as well as other alloy steels with proper hardenability characteristics and carbon content of 0.35 to 0.50, are suitable for gears requiring maximum wear resistance and high load-carrying capacity. Relatively shallow-hardening carbon steel gear materials, types 1040, 1050, 1137, and 1340, cannot be deep hardened and are suitable for gears requiring only a moderate degree of strength and impact resistance. A 4140 steel will produce a hardness of 300 to 350 Brinell. For heavy sections and applications requiring greater hardness, a 4340 steel will provide 350 to 400 Brinell. Cutting of gears in the 380 to 400 Brinell range, although practical, is generally difficult and slow.

**Nitriding** Nitriding is especially valuable when distortion must be held to a minimum. It is done at a low temperature (975 to 1050°F, 524 to 566°C) and without quenching—eliminating the causes of distortion common to other methods of hardening and often necessary for finish machining after hardening. Nitrided case depths are relatively shallow so nitriding is generally restricted to finer pitch gears (four-diameter pitch or finer). However, double-nitriding procedures have been developed for nitriding gears with as coarse as two diametral pitch.

Any of the steel alloys that contain nitride-forming elements, such as chromium, vanadium, or molybdenum, can be nitrided. Steels commonly nitrided are 4140, 4340, 6140, and 8740. It is possible with these steels to obtain core hardnesses of 300 to 340 Brinell and case hardnesses of 47 to 52 Rockwell C. Where harder cases are required, one of the Nitralloy steels may be used. These steels develop a case hardness of 65 to 70 Rockwell C with a core hardness of 300 to 340 Brinell. The depth of case in a 4140 or 4340 steel varies as the length of time in the nitriding furnace. A single nitride cycle will produce a case depth of 0.025 to 0.030 in (0.64 to 0.76 mm) in 72 h. Doubling the time will produce a case depth of 0.045 to 0.050 in (1.14 to 1.27 mm). For the majority of applications, the case depth obtained from a single cycle is ample.

Case depth for Nitralloy steels is somewhat less than the depths obtainable for other alloy steels. In general, alloy steels 4140 and 4340 give up to 50% deeper case than Nitralloy steels for the same furnace time. These cases are tougher but less hard.

**Induction Hardening** Two basic types of induction hardening are used by gear manufacturers: coil and tooth-to-tooth. The coil method consists of rotating the work piece inside a coil producing high-frequency electric current. The current causes the work piece to be heated. It is then immediately quenched in oil or water to produce the desired surface hardness. Hardnesses produced by this method range from 50 to 58 Rockwell C, depending on the material. The coil method hardens the entire tooth area to below the root.

Tooth-to-tooth full-contour induction hardening is an economical and effective method for surface hardening larger spur, helical, and herringbone gearing. In this process, an inductor passes along the contour of the tooth, producing a continuous hardened area from one tooth flank around the root and up the adjacent flank. The extremely high localized heat allows small sections to come to hardening temperature while the balance of the gear dissipates heat. Thus major distortions are eliminated. The 4140 and 4340 alloy steels are widely used for tooth-to-tooth induction hardening. The hardness of the case produced by

this method ranges from 50 to 58 Rockwell C, and the flanks may be hardened to a depth of 0.160 in (4.06 mm). These steels are air-quenched in the hardening process. Plain carbon steels, such as 1040 and 1045, may be used for induction hardening, but they must be water-quenched.

**Carburizing** Carburizing with subsequent surface hardening offers the best way to obtain the very high hardness needed for optimum gear life. It also produces the strongest gear, one that has excellent bending strength and high resistance to wear, pitting, and fatigue. The residual compressive stresses inherent in the carburized case substantially improve the fatigue characteristics of this heat-treated material. Normal case depths range from approximately 0.030 to 0.250 in (0.76 to 6.3 mm). Case hardnesses range from 55 to 62 Rockwell C, and core hardness from 250 to 320 Brinell. Recommended carburizing-grade steels are 4620, 4320, 3310, and 9310. The main limitation to carburizing and hardening is that the process tends to distort the gear. Techniques have been developed to minimize this distortion, but generally after carburizing and hardening, it is necessary to grind or lap the gear to maintain the required tooth tolerances.

**Flame Hardening** In tooth-to-tooth progressive flame hardening, an oxyacetylene flame is applied to the flanks of the gear teeth. After the surface has been heated to the proper temperature, it is air- or water-quenched. This method has some limitations; because the case does not extend into the root of the tooth, the durability is improved but the overall strength of the gear is not necessarily. In fact, stresses built up at the junction of a hardened soft material may actually weaken the tooth.

Many times it is desirable to use different heat treatments for the pinion and gears. Heat-treatment combinations used for pinions and gears are here listed in order of preference for optimum gear design.

1. Carburized pinion, carburized gear
2. Carburized pinion, through-hardened gear
3. Carburized pinion/nitrided gear
4. Nitrided pinion/nitrided gear
5. Nitrided pinion/through-hardened gear
6. Induction-hardened pinion/through-hardened gear
7. Carburized pinion/induction-hardened gear
8. Induction-hardened pinion/induction-hardened gear
9. Through-hardened pinion/through-hardened gear

## OPTIMIZING THE GEARING

---

The most important factor influencing the durability of a gear set, and hence the gear size, is the hardness of the gear teeth. It is often possible to reduce considerably—sometimes by as much as half—the overall dimensions of a gear set by changing from medium-hardened gears (about 300 Brinell) to full-hardened gears (about 55 to 60 Rockwell C).

Other factors play a role in minimizing the dimensions of a gear set; for example, the ratio between face width and pitch diameter and the proper pressure angle and pitch of teeth. Thus, when it comes to deciding between a set of standard catalog gears and gears designed specifically to meet the requirements of the application, the question of cost versus optimizing comes to bear. In general, where there is only a limited number of units to be made, the catalog gears are much less expensive and also much more readily available. There are many applications that call for critical power, speed, or space requirements,

however, and it may pay in these applications to select gears that are designed for that application.

**Minimizing Gear Noise** Specifying or designing a gear set to produce low noise and vibration levels frequently leads to choices that are the opposite of those for optimizing the gears for strength and size. Generally, a parallel-shaft gearing rather than right-angle gearing is preferred for quiet operation because of greater geometric control, inherent ability to maintain tight manufacturing tolerances, and minimum friction during tooth contact. Helical gears, in particular, can have more than one tooth in contact (helical overlap), and some experience has shown as much as a 12-dB reduction in noise using helical instead of spur gears. Double helical or herringbone gearing has the problem of manufacturing the two helices with precisely the same phase and accuracy. Helical gearing must have thrust bearings or collars on each element and so produce an overturning moment. The overturning moment is more pronounced with single stage high ratio units such as large diameter, narrow face-width gears, and small diameter pinions. These problems concerning double and single helical units are easily handled with proper design and manufacturing.

For quiet, smooth operation, the gears should be designed with some or all of the following properties:

1. Select the finest pitch allowable under load considerations.
2. Employ the lowest pressure angle:  $14\frac{1}{2}^\circ$  and  $20^\circ$  are most commonly used.
3. Modify the involute profile to include tip and root relief with a crowned flank to ensure smooth sliding into and out of contact without knocking and to compensate for small misalignments.
4. Allow adequate backlash (clearance) for thermal and centrifugal expansion, but not so much as to prevent proper contact.
5. Specify the higher AGMA quality levels, which will reduce the total dynamic load. Generally, AGMA quality 12 or better is required for smooth, quiet operation.
6. Maintain surface finishes of at least 20 microinches Ra (surface roughness average value).
7. Maintain rotor alignments and runouts accurately.
8. Limit rotor unbalance per plane to less than
 
$$U_{\max} = 3 W/N \text{ in US units, and } U_{\max} = 4760 W/N \text{ in SI units, where}$$

$$U_{\max} = \text{residual unbalance, oz} \cdot \text{in (g} \cdot \text{mm)}$$

$$W = \text{static weight on the journal, lb (kg)}$$

$$N = \text{maximum continuous speed, rpm}$$
9. Provide a nonintegral ratio (“hunting tooth”) to prevent a tooth on the pinion from periodically contacting the same teeth on the mating gear.
10. Have resonances of rotating system members (critical speeds) at least 30% away from operating speed, multiples of rotating speeds, and tooth-mesh frequencies.
11. Have resonances of gear cases and other supporting members 20% away from operating speeds, multiples, and tooth-mesh frequencies.
12. Specify the highest-viscosity lubricant consistent with design and application.
13. Select rolling element bearings to minimize noise generation. Generally, hydrodynamic sleeve bearings are quieter than antifriction types but are more difficult to apply.
14. Because housing design is another area where noise and vibration reductions can be obtained, select an acoustically absorbent material for the housing or design the housing with built-in isolation mounts to cut down any vibration attenuation.
15. For parallel shaft gearing, it is recommended that speed increasers be up meshed and speed reducers be down meshed to prevent rotor instability.

## PACKAGED GEAR DRIVES

---

In many cases, it is preferable to select a packaged gear drive rather than a set of open gears that must be mounted and housed.

The relative merits of a packaged drive, or “gear reducer,” versus open gearing are many. The packaged drive consists essentially of gears, housing, bearings, shafts, oil seals, and a positive means of lubrication. Frequently, reducers also include any or all of the following: electric motor and accessories, bedplates or motor supports, outboard bearings, a mechanical or electric device providing overload protection, a means of preventing reverse rotation, and other special features as specified.

The advantages of packaged gear drives have been well established and should be given consideration when selecting the type of gear drive for the application:

1. *Power conservation.* Because of accurate gear design, quality construction, proper bearings, and adequate lubrication, minimum loss between applied and delivered power is assured.
2. *Low maintenance.* If the correct design and power capacity for the requirements are selected and the recommended operating instructions are followed, low maintenance costs will result.
3. *Operating safety.* All gears, bearings, and shafts are enclosed in oil-tight, strongly built cast iron or steel housings.
4. *Low noise and vibration level.* Precision gearing is carefully balanced and mounted on accurate bearings. The transmitting motion is uniform and shock-free. The entire mechanism is tightly sealed in sound-damping rigid housing. Noise and vibration are reduced to a minimum.
5. *Space conservation.* Units are entirely self-contained and extremely compact; therefore, they require a small space. This also enables them to be installed in out-of-the-way locations.
6. *Adverse operating conditions.* Enclosure designs have been developed to protect the mechanism from dirt, dust, soot, abrasive substances, moisture, or acid fumes.
7. *Economy.* Units permit the use of high-speed prime movers directly connected to low applied speeds.
8. *Life expectancy.* The life of a unit can be predetermined by design and made unlimited if it is correctly aligned and properly maintained.
9. *Power and ratios.* Units are available in almost all desired ratios and for all practical power requirements.
10. *Cooling systems.* Greater attention to sump capacity for oil and the use of fan air cooling have allowed higher powers to be transmitted through smaller units without overheating.
11. *Appearance.* Housings have been streamlined for eye appeal as well as for reduction of weight and space.
12. *Rugged capabilities.* The ruggedness of steel-constructed welded housings and modern housings produces higher reliability and service life.

**Types of Gear Packages** Gear packages are used in multiple combinations to produce the ratio desired in the unit. Units are available in single-, double-, and triple-reduction configurations. Three stages of reduction are generally the maximum number used in standard reducers, although it is possible to use four or even more stages. Units for increasing the output speed generally have only one gear set, although at times two-stage units have been used successfully as speed increasers. Gear packages may be assembled with shaft arrangements that are right-handed or left-handed (Figure 7).

**ALLOWABLE SPEEDS OF GEAR REDUCERS** The maximum speed of a gear reducer is limited by the accuracy of the machined gear teeth, the balance of the rotating parts, the allowable

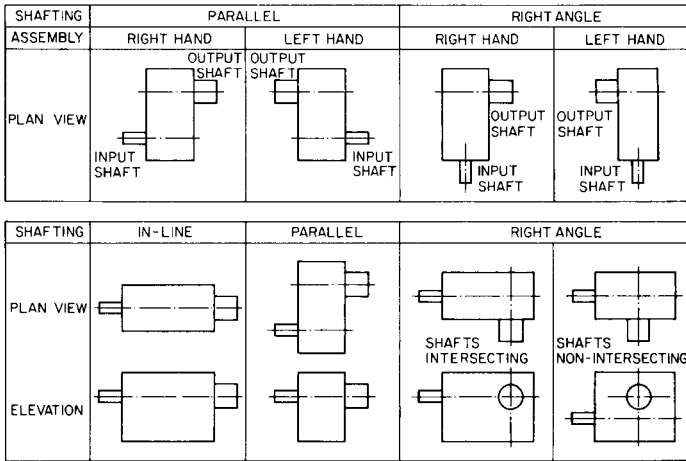


FIGURE 7 Shaft arrangements for gear drives

noise and vibration, the allowable maximum speed of the bearings, the pumping and churning of the lubricating oil, the friction of the oil seals, and the heat generated in the unit.

At high speeds, it is possible for inaccuracies in the gear teeth to produce failure even though no power is being transmitted. Gear reducers built in accordance with AGMA specifications are recommended to operate at speeds given in Table 1.

**POWER RANGE OF GEAR REDUCERS** The power-transmitting capacity of a reduction gear unit is a function of the output torque and the speed of the reducers. Some types of reducers, such as worm gear reducers, are more satisfactory for high torques and low speeds, whereas others, such as helical herringbone (or double helical), are suitable for high torques and also high speeds. Therefore the range of powers suitable for various units is considerable. A listing of this range obtainable in standard types of reducers is given in Table 1, with a brief explanation of why the range indicated is maintained. These powers are not fixed at the values given because they are continually changing. Although the values given are general, there are many special reducers available outside this range.

**RATIOS AND EFFICIENCIES** The ratio of a gear reducer is defined as the ratio of the input shaft speed to the output shaft speed. Different types of gearing allow different ratios per gear stage. Spur gears usually are used with a ratio range of 1:1 to 6:1; helical, double helical, and herringbone with ratios of 1:1 to 10:1; straight-bevel with ratios of 1:1 to 4:1; spiral-bevel (also zerols and hypoids) with ratios of 1:1 to 9:1; and worm gears with ratios of  $3\frac{1}{2}$ :1 to 90:1. Planetary gear arrangements allow ratios of 4:1 to 10:1 per gear stage.

Factors influencing the efficiency of a gear reducer are

1. Frictional loss in bearings
2. Losses due to pumping lubricating oil
3. Windage losses due to rotation of reducer parts
4. Frictional losses in gear tooth action

It is not uncommon in many types of reducers to have the combined losses due to items 1, 2, and 3 greater than the loss due to item 4. For this reason, in some cases the power lost in the reducer remains practically constant regardless of the power transmitted. Therefore, it must be realized that the efficiency specified for a reducer applies only when the

**TABLE 1** Guide for gear selection and design (reflecting generally accepted design criteria)

	Spur gearing		Helical gearing	
	External	Internal	External	Internal
Shaft arrangement	Parallel axis	Parallel axis	Parallel axis	Parallel axis
Ratio range	1:1 to 10:1	1½:1 to 10:1	1:1 to 15:1	2:1 to 15:1 (generally feasible) Ratio depends on pinion gear tooth combination because of clearance requirements
Size availability (including maximum face widths)	Up to 150-in (381-cm) OD, 30-in (76.2-cm) face width. Larger segmental gears can be produced with special processing and tooling	Up to 100-in (254-cm) OD, 16-in (406-cm) face width	Up to 150-in (381-cm) OD, 30-in (76.2-cm) face width	Up to 100 in (254 cm), depending on blank configuration; 16-in (406-cm) maximum face width
Gear tolerances (quality requirements)	See footnote.	See footnote.	See footnote.	See footnote.
Finishing methods (singly or in combination)	Cast: rotary cut, shaped; hobbed: shaved, ground	Same as external spurs	Shaped, bobbed, shaved, ground	Shaped, bobbed, shaved, honed, lapped, ground
Power range, hp (kW)	Commercial: less than 1000 (750)		Commercial: generally up to 50,000 (37,000) However, power limited only by maximum size capacity of design	Same as external helical gearing
Speed range, pitch line velocity	Commercial: normal up to 1000 (300); special precision up to 20,000 (6100)	Commercial, standard manufacture: up to 1000 (300); precision manufacture: up to 20,000 (6100)	To 30,000 (9100)	

**TABLE 1** Continued.

	Spur gearing		Helical gearing	
	External	Internal	External	Internal
Gear efficiency, %	Commercial: 95 to 98		97 to 99	
Quietness of operation	Commercial: quiet under 500 ft/min (150 m/min); noise increases with increasing pitch-line velocity		Noise level depends on quality of gear. Higher pitch line velocity (above 5000 ft/min (1500 m/min)) requires higher precision gear. Gears operating 30,000 ft/min (9100 m/min) have been made with overall noise level below 90 dB. Quieter than spur gears.	
Load imposed on bearings	Radial only		Radial and thrust	Radial and thrust
	External double helical gearing		Continuous-tooth herringbone gearing	
Shaft arrangement	Parallel axis		Parallel axis	
Ratio range	1:1 to 15:1		1:1 to 10:1	
Size availability (including maximum face widths)	Up to 150-in (381-cm) OD, 30-in (76.2-cm) face width		Up to 150-in (381-cm) OD, 30-in (76.2-cm) face width	
Gear tolerances (quality requirements)	See footnote.		See footnote.	
Finishing methods (singly or in combination)	Same as helical gearing		Shaped, shaved	

**TABLE 1** Continued.

	External double helical gearing		Continuous-tooth herringbone gearing	
Power range, hp (kW)	Same as helical gearing		Up to 2000 (1500)	
Speed range pitch line velocity, ft/min (m/min)	Same as helical gearing		Commercial: up to 5000 (1500)	
Gear efficiency, %	Same as helical gearing		96 to 98	
Quietness of operation	Same as helical gearing		Quiet operation up to 5000 ft/min (1500 m/min). Not generally used at extremely high pitch line velocity, over 20,000 ft/min (6100 m/min).	
Load imposed on bearings	Radial only		Radial only	
	Straight-bevel gearing	Spiral-bevel gearing	Zerol-bevel gearing	Hypoid gearing
Shaft arrangement	Intersecting axis	Intersecting axis	Intersecting axis	Nonintersecting, nonparallel axis
Ratio range	1:1 to 6:1	1:1 to 10:1	1:1 to 10:1	1:1 to 10:1
Size availability (including maximum face widths)	Up to 102-in (55-cm) OD, 12-in (30.5-cm) face width	Up to 102-in (55-cm) OD, 12-in (30.5-cm) face width	102-in (55-cm) OD, 12-in (30.5-cm) face	102-in (55-cm) OD, 12-in (30.5-cm) face
Gear tolerances (quality requirements)	See footnote.	See footnote.	See footnote.	
Finishing methods (singly or in combination)	Cast, generated, planed	Generated, planed, ground	Generated, planed, ground	Generated, planed, ground
Power range, hp (kW)	Up to 1,500 (1120)	Up to 20,000 (15,000), depending on speed	Same as straight bevel gears	Same as spiral bevel gears, with use of EP lubricants



**TABLE 1** Continued.

	Straight-bevel gearing	Spiral-bevel gearing	Zerol-bevel gearing	Hypoid gearing
Speed range pitch line velocity, ft/min (m/min)	Same as spur gearing	Commercial, normal: up to 5,000 (1500); special precision; up to 15,000 (4500)	Up to 15,000 (4500) for ground gears	6,000 (1800) to 10,000 (3000), depending on offset
Gear efficiency, %	Same as spur gearing	96 to 98 (commercial)	94 to 98	85 to 98, depending on offset
Quietness of operation	Same as spur gearing	Noise level depends on quality of gear. Higher pitch line velocity—above 5,000 ft/min (1500 m/min)—requires higher precision gear.	Quieter than straight-bevel gears	Quiet
Load imposed on bearings	Radial and thrust	Radial and thrust	Radial and thrust	Radial and thrust
	Worm gearing			
	Cylindrical		Double-enveloping cone-drive gears	
Shaft arrangement	Nonintersecting, nonparallel axis		Right angle in single-reduction units	
Ratio range	$3\frac{1}{2}$ :1 to 100:1		5:1 to 70:1	
Size availability (including maximum face widths)	300-in (762-cm) OD, 4-in (10.2-cm) circular pitch		2- to 24-in (5.1- to 61-cm) center distance. For special requirements, larger and smaller sizes are available.	
Gear tolerances (quality requirements)	Worm gear tolerances given in AGMA Standard: Inspection of Course-Pitch Cylindrical Works and Worm Gears, Standard No. 234.01		Standard AGMA commercial tolerances. Closer tolerances available for special applications	

**TABLE 1** Continued.

	Worm gearing	
	Cylindrical	Double-enveloping cone-drive gears
Finishing methods (singly or in combination)	Worm gears: hobbed, worm-milled, and ground	Worms: threads generated with cutter and finished by polishing. Gears: hobbed. Both members then lapped and matched together
Power range, hp (kW)	Up to 400 (300)	Fractional to 1,430 (1070) dependent on ratio, center distance, and speed
Speed range pitch line velocity, ft/min (m/min)	Up to 6000 (1830)	0 to 2400 rpm, or 2000 (610) rubbing speed with splash lubrication. Higher speeds permissible with special combinations.
Gear efficiency, %	From 25 to 95, depending on ratio	52 to 94, depending on ratio and speed
Quietness of operation	Relatively quiet operation up to 6000 ft/min (1830 m/min)	Smooth and quiet up to 2000 ft/min (610 m/min); can run quietly at higher speeds with special attention to lubrication, mounting, materials, balancing, and so on.
Load imposed on bearings	Radial and thrust	Radial and thrust

Gear tolerances are dependent on method of manufacture, application, load requirements, and speeds. For spur, helical, and herringbone gears, ANSI/AGMA Gear Classification Manual 2000 A-88 lists quality numbers from 3 to 15 for coarse-pitch gears and 5 to 16 for fine-pitch gears, quality increasing as quality number increases. The general range of quality for gears now being manufactured is from quality numbers 5 to 14. Quality numbers relate to runout, tooth-to-tooth, spacing, profile, total composite, and lead tolerances. Bevel and hypoid gear tolerances range from 3 to 13.

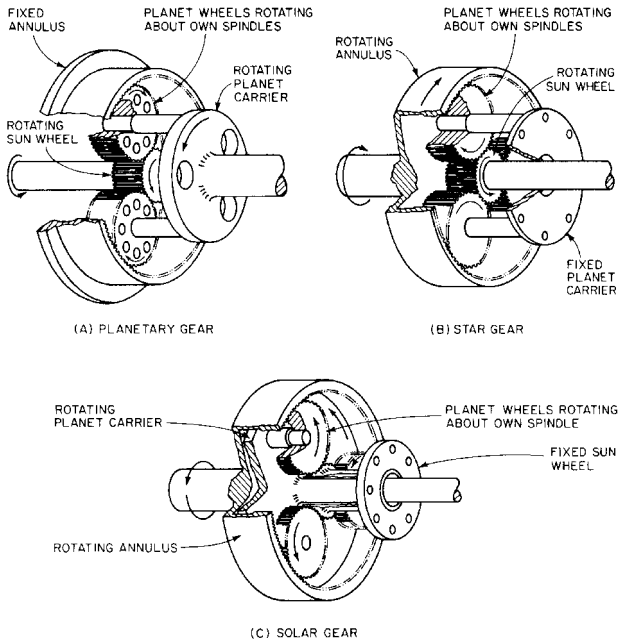


FIGURE 8 Single epicyclic gear drives

unit is transmitting its rated power because when no power is being transmitted through the reducer, all the input power (small as it may be) is used in friction and the efficiency is zero.

Ratios available in standard reducers and efficiencies to be expected when units are transmitting rated power are given in Table 1.

**Epicyclic Gear Units** Epicyclic gear units are sometimes used for pump drive applications. The important advantages are compact configuration, coaxial shafts, and light weight.

The most common types of epicyclic arrangements are planetary, star, and solar (Figure 8). The planetary configuration (with the planet carriers integral with the output shaft) is the most commonly used arrangement. It is simple and rugged and gives the maximum ratio for the size of gears. The star arrangement (where the planet carrier is fixed and the internal gear rotates integrally with the output shaft) is used for higher-speed applications because centrifugal loads of the planet gears are eliminated with nonrotating planet carrier. The solar arrangement (where the pinion is fixed and the planet carrier is integral with the output shaft) has the input through the internal gear. This arrangement gives epicyclic advantages but allows a low ratio, generally less than 2:1. Higher ratios (in the range of 8:1 to 60:1) can be obtained utilizing double-reduction or compound-planetary arrangements.

## INSTALLATION

The basic gear unit is generally shipped from the factory completely assembled. Mating gears and pinions are carefully assembled at the factory to provide proper tooth contact. Nothing should be done to disturb this setting.

**Solid Foundation** The reducer foundation should be rigid enough to maintain correct alignment with connected machinery. The foundation should have a flat mounting surface in order to assure uniform support for the unit. If the unit is mounted on a surface other than horizontal, consult the factory to ensure that the design provides for proper tooth contact and adequate lubrication.

The design of fabricated pedestals or baseplates for mounting speed reducers should be carefully analyzed to determine that they are sufficiently rigid to withstand operating vibrations. Vibration dampening materials may be used under the baseplate to minimize the effect of vibrations.

When mounting a drive on structural steel, the use of a rigid baseplate is strongly recommended. Bolt unit and baseplate securely to steel supports with proper shimming to ensure a level surface.

If a drive is mounted on a concrete foundation, allow the concrete to set firmly before bolting down the unit. For the best mounting, grout structural steel mounting pads into the concrete base rather than grouting the gear unit directly into the concrete.

The gear unit inspection covers should be removed and a tooth contact check be performed using a color transfer material to ensure that the contact in the field is the same as when checked in the manufacturer's shop during assembly. This should be done regardless of whether the gear unit was mounted in the field or received on a bedplate.

**Leveling** If shims are employed to level or align the unit, they should be distributed evenly around the base under all mounting pads to equalize the support load and to avoid distortion of the housing and highly localized stresses. All pads must be squarely supported to prevent distortion of the housing when the unit is bolted down.

**Alignment** If the equipment is received mounted on a bedplate, it has been aligned at the factory. However, it may have become misaligned in transit. During field mounting of the complete assembly, it is always necessary to check alignment by breaking the coupling connection and shimming the bedplate under the mounting pads until the equipment is properly aligned. All bolting to the bedplate and foundation must be pulled up tight. After satisfactory alignment is obtained, close up the coupling.

**Couplings** Drive shafts should be connected with flexible couplings. The couplings should be aligned as closely as possible following the manufacturer's instructions. However, many of the coupling manufacturers publish catalog values that are actually "jam angles." A coupling aligned to within four (4) minutes of a degree at operating temperature will operate satisfactorily in nearly any combination of torque and speed within its design limits. Four (4) minutes of a degree is about 0.0006 in/in (0.0006 mm/mm) of engagement separation.

Thrust from the connected equipment can be transmitted across the coupling to the gear. Caution should be exercised to assure that the proper shaft to shaft end spacing is maintained to minimize external thrust force.

**Alignment and Bolting** The gear unit, together with the prime mover and the driven machine, should be correctly aligned. After precise alignment, each member must be securely bolted and doweled in place. Coupling alignment instructions should be carefully followed. Prior to initial operation, each member must be shallow doweled in place. After the system has been checked at operating temperature, the dowels should be sunk to their proper depth.

## LUBRICATION

---

**Types of Lubricant** The recommended types of oil for use in gear units are either straight mineral oil or extreme-pressure (EP) oil. In general, the straight mineral oil should be a high grade, well-refined petroleum oil within the recommended viscosity range. It must be neutral in reaction and not corrosive to gears and ball or roller bear-

ings. It should have good defoaming properties and good resistance to oxidation for high operating temperatures.

Gear drives that are subject to heavy shock, impact loading, or extremely heavy duty should use an EP lubricant. EP gear lubricants are petroleum-based lubricants containing special chemical additives. The ones most recommended contain sulfur-phosphorous additives. Sulfur-phosphorous EP oils may be used to a maximum sump temperature of 180°F (82°C).

In general, if units are subjected to unusually high ambient temperatures (100°F, 38°C or higher), extreme humidity, or atmospheric contaminants, use the straight mineral oil recommended.

**Grease Lubrication** The lubricant should be high-grade, nonseparating, ball bearing grease suitable for operating temperatures to 180°F (82°C). Grease should be NLGI No. 2 consistency.

The grease lubricant must be noncorrosive to ball or roller bearings and must be neutral in reaction. It should contain no grit, abrasive, or fillers; it should not precipitate sediment; it should not separate at temperatures up to 300°F (149°C); and it should have moisture-resistant characteristics and good resistance to oxidation.

**Grease Lubrication of Bearings** Pressure fittings are often supplied in gear units for the application of grease to bearings that are shielded from the oil. Although a film or grease over the rollers and races of the bearing is sufficient lubrication, drives are generally designed with ample reservoirs at each grease point.

Greased bearings should be lubricated at definite intervals. Usually one-month intervals are satisfactory unless experience indicates that regreasing should occur at shorter or longer intervals.

**Oil Seals** Oil seals require a small amount of lubricant to prevent frictional heat and subsequent destruction when the shaft is rotating. Normally when a single seal is utilized, sufficient lubricant is provided by spray or splash. Certain design or application requirements dictate that double seals be used at some sealing points. When this is the case, a grease fitting and relief plug are located in the seal retainer to provide lubricant to the outer seal. Grease must periodically be applied between the seals by pumping through the fitting until overflow is noted by the relief plug. The greases recommended for bearings may also be used for seals.

## TROUBLESHOOTING TIPS

---

Improper lubrication causes a high percentage of gear reduction unit failures. Too frequently, speed reducers are started up without any lubricant at all. Conversely, units are sometimes filled to a higher oil level than specified in the mistaken belief that better lubrication is obtained. This higher oil level usually results in more of the input power going into churning the oil, creating excessive temperatures with detrimental results to the bearings and gearing. Insufficient lubrication gives the same results.

Gear failure due to overload is a broad and varied area of misapplication. The nature of the load (input torque, output torque, duration of operating cycle, shocks, speed, acceleration, and so on) determines the gear unit size and other design criteria. Frequently, a gear drive must be larger than the torque output capability of the severity of application conditions by providing a higher nominal power that in effect increases the size of the gear unit. If there is any question in the user's mind that the actual service conditions may be more severe than originally anticipated, it is recommended that this information be communicated to the gear manufacturer before start-up. Often there are remedies that can be suggested before a gear unit is damaged by overload, but none are effective after severe damage.

Motors and other prime movers should be analyzed while driving the gear unit under fully loaded conditions to determine that the prime mover is not overloaded and

thus putting out more than the rated torque. If it is determined that overload does exist, the unit should be stopped and steps taken either to remove the overload or to contact the manufacturer to determine suitability of the gear drive under the observed conditions.

Table 2 is an extensive troubleshooting chart that should be consulted whenever necessary.

**TABLE 2** Troubleshooting chart

Trouble	What to inspect	Action
Overheating	1. Unit overload	Reduce loading or replace with drive of sufficient capacity.
	2. Oil-cooler operation	Check coolant and oil flow. Vent system of air. Oil temperatures into unit should be approximately 110°F (43°C). Check cooler internally for build-up of deposits from coolant water.
	3. Oil level	Check oil level indicator to see that housing is accurately filled with lubricant to the specified level.
	4. Bearings adjustment	Bearings must not be pinched. Adjustable tapered bearings must be set at proper bearing lateral clearance. All shafts should spin freely when disconnected from load.
	5. Oil seals or stuffing box	Oil seals should be greased on those units having grease fitting for this purpose. Otherwise, apply small quantity of oil externally at the lip until seal is run in. Stuffing box should be gradually tightened to avoid overheating. Packing should be self-lubricating braided-type.
	6. Breather	Breather should be open and clean. Clean breather regularly in a solvent.
	7. Grade of oil	Oil must be of grade specified in lubrication instructions. If not, clean unit and refill with correct grade.
	8. Condition of oil	Check to see if oil is oxidized, dirty, or of high sludge content; change oil and clean filter.
	9. Forced-feed lubrication system	Make sure oil pump is functioning. Check that oil passages are clear and permit free flow of lubricant. Inspect oil line pressure regulators, nozzles, and filters to be sure they are free of obstructions. Make sure pump suction is not sucking air.
	10. Coupling alignment	Disconnect couplings and check alignment. Realign as required.
	11. Coupling lateral float	Adjust spacing between drive motor, and so on, to eliminate end pressure on shafts. Replace flexible coupling with type allowing required lateral float.
	12. Speed of unit	Reduce speed or replace with drive suitable for speed.

TABLE 2 Continued.

Trouble	What to inspect	Action
Shaft failure	1. Type of coupling used	Rigid couplings can cause shaft failure. Replace with coupling that provides required flexibility and lateral float.
	2. Coupling alignment	Realign equipment as required.
	3. Overhung load	Reduce overhung load. Use outboard bearing or replace with unit having sufficient capacity.
	4. Unit overload	Reduce loading or replace with drive of sufficient capacity.
	5. Presence of high-energy loads or extreme repetitive shocks	Apply couplings capable of absorbing shocks and, if necessary, replace with drive of sufficient capacity to withstand shock loads.
	6. Torsional or lateral vibration condition	These vibrations can occur through a particular speed range. Reduce speed to at least 25% below critical speed. System mass elastic characteristics can be adjusted to control critical speed location. If necessary, adjust coupling weight, as well as shaft stiffness, length, and diameter. For specific recommendations, contact factory.
	7. Alignment of outboard bearing	Realign bearing as required.
Bearing failure	1. Unit overload	See "Overheating" (item 1). Abnormal loading results in flaking, cracks, and fractures of the bearing.
	2. Overhung load	See "Shaft Failures" (item 3).
	3. Bearing speed	See "Overheating" (item 12).
	4. Coupling alignment	See "Overheating" (item 10).
	5. Coupling lateral float	See "Overheating" (item 11).
	6. Bearings adjustment	See "Overheating" (item 4). If bearing is too free or not square with axis, erratic wear pattern will appear in bearing races.
	7. Bearings lubrication	See "Overheating" (items 2, 3, 7, 8, 9). Improper lubrication causes excessive wear and discoloration of bearing.
	8. Rust formation due to entrance of water or humidity	Make necessary provisions to prevent entrance of water. Use lubricant with good rust-inhibiting properties. Make sure bearings are covered with sufficient lubricant. Turn over gear unit more frequently during prolonged shutdown periods.

TABLE 2 Continued.

Trouble	What to inspect	Action
	9. Bearing exposure to abrasive substance	Abrasive substance will cause excessive wear, evidenced by dulled balls, rollers, and raceways. Make necessary provision to prevent entrance of abrasive substance. Clean and flush drive thoroughly and add new oil.
	10. Damage due to improper storage or prolonged shutdown	Prolonged periods of storage in moist air and at ambient temperatures will cause destructive rusting of bearings and gears. When these conditions are found to have existed, the unit must be disassembled and inspected and damaged parts either thoroughly cleaned of rust or replaced.
Oil leakage	1. Oil	Check through level indicator that oil level is precisely at level indicated on housing.
	2. Open breather	Breather should be open and clean.
	3. Open oil drains	Check that all oil drain locations are clean and permit free flow. Drains are normally drilled in the housing between bearings and bearing cap where shafts extend through caps.
	4. Oil seals	Check oil seals and replace if worn. Check condition of shaft under seal and polish if necessary. Slight leakage normal, required to minimize friction and heat.
	5. Stuffing boxes	Adjust or replace packing. Tighten packing gradually to break in. Check condition of shaft and polish if necessary.
	6. Force-feed lubrication to bearing	Reduce flow of lubricant to bearing by adjusting orifices. Refer to factory.
	7. Plugs at drains, levels, and so on, and standard	Apply pipe joint sealant and tighten fittings.
	8. Compression-type pipe fittings	Tighten fitting or disassemble and check that collar is properly gripping tube.
	9. Housing and caps	Tighten cap screws or bolts. If not entirely effective, remove housing cover and caps. Clean mating surfaces and apply new sealing compound (Permatex #2 or equal). Reassemble. Check compression joints by tightening fasteners firmly.
Gear wear	1. Backlash	Gear set must be adjusted to give proper backlash. Refer to factory.
	2. Misalignment of gears	Make sure that contact pattern is above approximately 75% of race, preferably in center area. Check condition of bearings.
	3. Twisted or distorted housing	Check shimming and stiffness of foundation.



**TABLE 2** Continued.

Trouble	What to inspect	Action
	4. Unit overload	See "Overheating" (item 1).
	5. Oil level	See "Overheating" (item 3).
	6. Bearings adjustment	See "Overheating" (item 4).
	7. Grade of oil	See "Overheating" (item 7).
	8. Condition of oil	See "Overheating" (item 8).
	9. Forced-feed lubrication	See "Overheating" (item 9).
	10. Coupling alignment	See "Overheating" (item 10).
	11. Coupling lateral float	See "Overheating" (item 11).
	12. Excessive speeds	See "Overheating" (item 12).
	13. Torsional or lateral vibration	"See Shaft Failure" (item 6).
	14. Rust formation due to entrance of water or humidity	See "Bearing Failure" (item 8).
	15. Gears exposure to abrasive substance	See "Bearing Failure" (item 9).

**FURTHER READING**

AGMA: *AGMA Standards and Technical Publications Index*, AGMA 000-67, 1500 King Street, Suite 201, Alexandria, VA 22314.

Dudley, D. W. *Handbook of Practical Gear Design*. McGraw-Hill, New York, 1984.

"Gear Drives." *Design News*, January 19, 1968.

Hamilton, J. M. "Are You Paying Too Much for Gears?" *Mach. Design*, October 19, 1972.

Kron, H. O. "Optimum Design of Parallel Shaft Gearing." *Trans. ASME*, 72PTG-17, Oct. 1972.

Philadelphia Gear Corporation. *Philadelphia Application Engineered Gearing Catalog*, G-76, King of Prussia, PA, 1976.

Rosaler, R. C., and Rice, J. O. *Standard Handbook of Plant Engineering*. McGraw-Hill, New York, 1983.

# 6.2.5 ADJUSTABLE-SPEED BELT DRIVES

MILTON B. SNYDER

Mechanical adjustable-speed drives for pump applications are generally of the compound adjustable-pitch-sheave and rubber-belt variety, as illustrated in Figures 1 and 2. The integrated drive package converts constant input speed to an output that is steplessly variable within a certain range. The drive packages are usually driven by constant-speed ac induction motors and usually contains built-in gear reducers to obtain low output speeds.

Drive packages may be mounted horizontally, vertically, or on a 45° angle and are available in standard open or totally enclosed designs. Some of the possible mounting arrangements are illustrated by Figure 3. Speed ranges of 10:1 to 2:1 can be obtained with most units. A typical distribution of available output speeds is 4550 to 1.4 rpm, including drives with and without reducer gearing. Increaser gearing (offered as an integrally mounted package) provides speeds to 16,000 rpm.

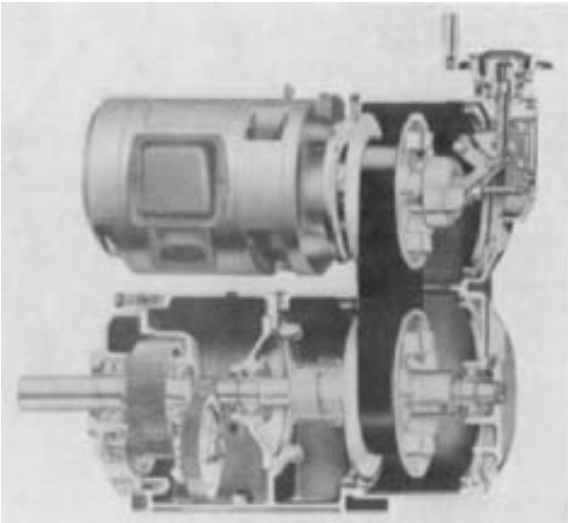
Alternating-current induction-drive motors used with mechanical adjustable-speed drives usually operate at a speed of 1750 or 1160 rpm. The electric design characteristics of these motors comply with the standards if the National Electrical Manufacturers Association (NEMA). The NEMA design B motor with normal torque and normal slip characteristics is standard. NEMA design C (high torque low starting current) and NEMA design D (high torque, high slip) motors may be used when their specific characteristics are dictated by the application.

The mechanical mounting characteristics of the drive motors for mechanical adjustable-speed drives vary from one manufacturer to another. Motors of round body, footless, NEMA C-face construction are commonly used. Sometimes standard foot-mounted motors are supplied as an option in conjunction with a scoop support by some manufacturers or as standard practice by others until others may supply mechanically special partial motor frames with their drives.

For a given power rating, many manufacturers will supply drive motors with increased service-factor power. This increased power of the drive motor compensates for and overcomes the inherent mechanical losses of the drive. This in turn causes full-rated power to



**FIGURE 1** Pump application utilizing typical mechanical adjustable-speed belt drives (Reliance Electric)



**FIGURE 2** Cutaway view of typical mechanical adjustable-speed drive (Reliance Electric)

be developed at the output shaft of the mechanical adjustable-speed drive. Drive output power ratings are more fully discussed under "Rating Basis."

The input speed of the mechanical adjustable-speed drive is typically 1750 or 1160 rpm, as defined by the speed of the drive motor. The output speed of the internal adjustable-speed belt section goes above and below the drive motor speed. A maximum speed of 4200 rpm or greater is not uncommon for fractional and small-integral power drives. The need for stages of output gearing to obtain final output speeds that are usable for pump or other applications is therefore readily apparent.



**FIGURE 3** Mechanical adjustable-speed drive mounting and special enclosures

Parallel-shaft or right-angle-shaft reducer gearing, at the option of the design engineer or user, may be incorporated as an integral part of the mechanical adjustable-speed drive package. Generally speaking, gear reduction is required when drive maximum output speed must be lower than 1750 rpm or drive minimum output speed lower than 583 rpm.

The American Gear Manufacturers Association (AGMA) does not define standards for reducers used in adjustable-speed applications. However, most all drive manufacturers produce reducers for these drives in accordance with accepted AGMA standards for constant-speed reducers.

Where infinite, or stepless, adjustment over a specific finite speed range is necessary, stepless mechanical adjustable-speed drives are generally most economical for standard pump application requirements. Initial costs are usually lower than for comparable electric or hydraulic systems, and the mechanical systems are easier to operate and maintain.

Reliability and accuracy of speed control are advantages of the mechanical adjustable-speed belt drive package. Construction details, size, and mounting dimensions are not

standardized and vary with the manufacturer but all employ dual adjustable-pitch sheaves mounted on parallel shafts at a fixed center distance and a special wide-section rubber V belt to provide a compact assembly. Most of the designs utilize spring-loaded sheaves for control of belt tension.

A high degree of control and flexibility in application is offered by mechanical adjustable-speed belt drive power packages. Capacities range from fractional to 100 hp (75 kW), with maximum speed ratios of 10:1 in the fractional power sizes, decreasing to 6:1 at 30 hp (22 kW) and 3: 1 in the largest sizes. Multiple-belt drive arrangements are usually required for capacities over 50 hp (37 kW). Again, depending on capacity, speeds ranging from a maximum of 16,000 to a minimum of 1.4 rpm are possible, although most of the standard units are within the 2 to 5000 rpm range.

### OPERATING PRINCIPLE

In Figure 4, the upper disk assembly is the input assembly driven directly by the shaft of the ac induction motor at a constant speed. This constant-speed disk assembly has one stationary disk member on the *left* and one movable, or sliding, disk member on the *right*. The sliding member is mechanically attached to a positive shifting linkage arrangement consisting of a thrust bearing, bearing housing, and shifting yoke. This linkage is actuated by a control hand-wheel or some other speed-changing device.

In the same view, the lower disk assembly is the output assembly, whose speed is adjustable. In this adjustable-speed disk assembly, the sliding member is next to the spring cartridge on the *left* and the stationary member is on the *right*. Note that this arrangement is just the opposite of that for the upper, or constant-speed, disk assembly. This adjustable-speed output shaft of the drive. A flexible, wide-section, rubber V belt connects the two disk assemblies.

Assuming the minimum speed belt position as a starting point, the positive shifting linkage or the sliding member of the constant-speed disk assembly is moved to the left toward the fixed member. This positive change forces the wide-section V belt to a larger diameter in the constant-speed disk assembly. Simultaneously, the belt forces the sliding member on the adjustable-speed disk assembly against its spring so the belt assumes a smaller running, or pitch, diameter in this disk assembly. The speed of the output shaft increases in stepless increments, whereas the drive motor speed remains constant. Reversing the previous procedures reduces the output shaft speed.

When the V belt is at this maximum diameter in the constant-speed disk assembly, it is at a minimum diameter in the adjustable-speed disk assembly and the output shaft speed is at maximum. Conversely, when the V belt is at its minimum diameter in the constant-speed disk assembly, it is at a maximum diameter in the adjustable speed disk assembly and the output shaft speed is at minimum.

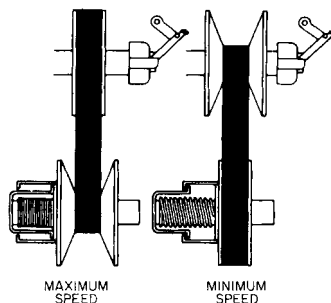


FIGURE 4 Functional diagram for a mechanical adjustable-speed drive belt section (Reliance Electric)

Because one member of each disk assembly is fixed on its shaft, the V belt must move axially as well as along the inclined surface of the disk to assume different diameters and cause the speed to change. Centrifugal force makes this composite movement of the belt effortless when the drive is in operation, but the speed setting of the drive must never be changed while the drive is not operating and motionless. If speed-setting change is attempted while the drive is motionless, destructive, crushing forces are imposed on the belt. These same forces may also damage the positive shifting linkage of the otherwise rugged mechanical adjustable-speed drive.

## **OTHER BELT DRIVES**

---

Other drives of the mechanical adjustable-speed type, such as the single adjustable-motor-sheave or pulley and the wood block or metal-chain-belt type transmission, are only mentioned briefly here because of their rather limited application as pump drives.

The motor sheave, or pulley, illustrated in Figure 5, is a simple, single, adjustable-pitch device mounted on a motor shaft. It drives by way of a standard or wide-section V belt to a companion fixed-diameter, flat-face pulley, or V sheave. Driving and driven shafts are parallel but must be arranged so their center distance is adjustable; this is generally accomplished by means of a sliding motor base. The entire base assembly is usually operated as an open belt drive.

The wood-block or metal-chain belt transmission uses the original mechanical adjustable-speed belt drive operating principle. This drive utilizes a special wide-section wood-block belt or laminated-metal-chain belt driven by two pairs of positively controlled variable-pitch sheaves. Movement of the sheave flanges is synchronized by a positive linkage arrangement.

The transmission-type drive is generally thought of as a low-speed, high-torque device that can withstand severe overload and abuse for long periods of time.

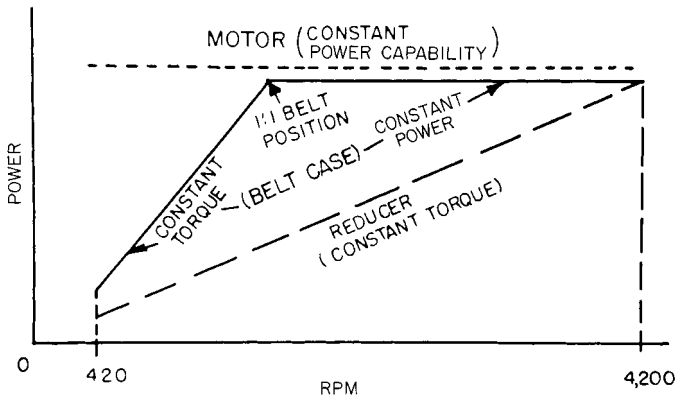
## **RATING BASIS**

---

The mechanical adjustable-speed drive package is usually rated as a constant-torque, variable-power device. The power rating is based upon the capacity of the whole unit at maximum speed setting. When operating at any output speed below this maximum, the power capacity is reduced in direct proportion.



**FIGURE 5** Typical motor pulley belt drive with adjustable center distance between driving and driven shafts (Reliance Electric)



**FIGURE 6** Power versus output speed relationship for the motor, belt section, and reducer section of a mechanical adjustable-speed belt drive

A drive unit is made up of three major components, each of which has its own individual torque or power output characteristics. For example, the ac induction-drive motor or prime mover develops constant power at a constant rotational speed.

The adjustable-speed belt section has an output torque characteristic that is a mixture of both constant torque and variable torque over its speed range. This section has a constant-power, variable-torque characteristic when operating above a 1:1 belt position and a constant-torque variable-power characteristic when operating below a 1:1 belt position. Finally, a parallel-shaft or right-angle gear reducer section has a constant-torque, variable-power characteristic. Figure 6 graphically illustrates these relationships.

Because the gear reducer section has a constant-torque characteristic, this section defines the output characteristic for the entire mechanical adjustable-speed drive.

It should be noted that virtually all manufacturers rate parallel-shaft drives using output shaft power as a base, whereas right-angle output shaft drives are rated on the basis of input power to the reducer minus reducer efficiency.

Because of the relatively low efficiency of the right-angle worm gear reducers and right-angle combination worm and helical gear reducers, the power transmission industry follows the practice of rating these units in terms of power at the input shaft. From the earlier discussion on operating principle, you will note that the adjustable-speed output shaft of the belt section of the drive becomes the input shaft of the reducer section of the same drive.

One or more sections of a drive, usually the belt and reducer sections, may be service-factored by frame or case oversizing to permit the rating of these sections for constant power over all or a portion of their speed range. Because the drive motor is a constant-power device, as already mentioned, oversizing of its frame is unnecessary.

## SERVICE FACTORING

Service factoring of a mechanical adjustable-speed belt drive is common practice when the normal operating requirements for steady constant-torque loads running 8 hours/day, 5 days/week are to be exceeded.

Drives to be used other-than-normal service as previously described must be selected by use of modifying factors that will provide correct service capacity. Some unusual service requirements are moderate to heavy shock loads, 24 hours/day continuous operation, and constant-power demands over a wide speed range.

Other unusual service conditions may be suggested by the following information check list. This list itemizes required information data that should be furnished to the variable-speed drive manufacturer for those applications calling for unusual service.

1. Speed and torque required for the application
2. Value and frequency of peak-load conditions
3. Hours of operation per day or week
4. Frequency of starts and stops
5. Inertia ( $WK^2$ ) of the load
6. Frequency of reversals of rotation direction
7. Electric and mechanical overload protection provisions
8. Method used to connect drive output shaft to driven load
9. Any unusual environment or other operating condition

### **METHODS OF CONTROL**

---

A variety of control systems have been developed for use with mechanical adjustable-speed drives. For the majority of pump applications, speed is controlled manually through a lever, handwheel, or knob attachment. Remote semiautomatic and automatic control methods in mechanical, pneumatic, or electric forms are also being used.

For manual operation, vernier attachments are often useful to increase the accuracy of speed adjustment. Cams are occasionally employed, mounted externally or internally, to assure a prescribed pattern of output characteristics.

Remote control is usually obtained by means of a positioning motor, which is a fractional-power motor connected to the drive control shifting screw through reduction gearing. The output speed of the drive is then adjusted from a station at a remote location.

For semiautomatic or automatic operation, control systems usually consist of three elements: a sensing unit, a receiver, and a positioning actuator. The sensing unit detects changes in the process being controlled and transmits a signal to the receiver. At the receiver, the signal is analyzed, amplified, and transmitted to the positioning actuator, which adjusts the speed of the mechanical adjustable-speed drive accordingly.

If the process or load requirements can be adapted to produce a signal, there should be a suitable control system that can be used for speed adjustment. The only limitation is that the load requirements must follow a specific pattern of some type, regardless of whether the pattern is based on direct, inverse, or proportional relationships.

The pneumatic actuators used for speed adjustment are usually responsive to a 3 to 15-lb/in<sup>2</sup> (20- to 100-kPa) air signal pressure. These pneumatic positioning devices are actually analog piloted servovalve positioning devices that can be used in a great variety of open- and closed-loop process control applications. They can be used to cause a mechanical adjustable-speed drive to either flow or maintain a given process signal from variables such as liquid level, pressure, flow rate, or any other measurable value. The adjustable-speed drive thus becomes the final control element in a closed-loop process control system. Figure 7 is a typical drive equipped with a pneumatic actuator for speed changing.

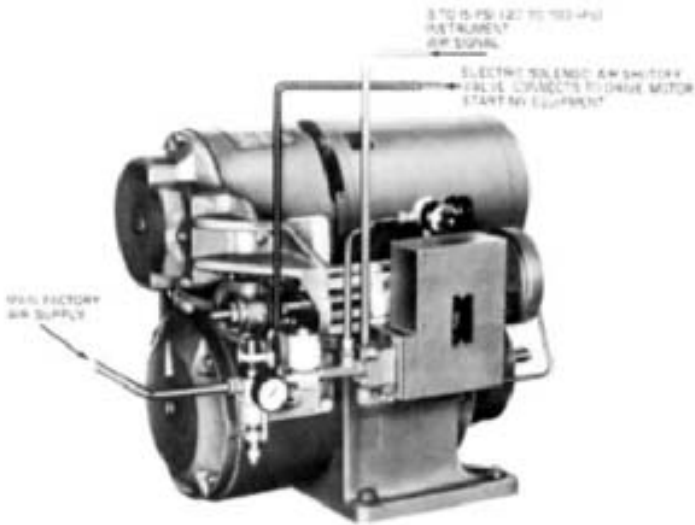
### **APPLICATION GUIDELINES**

---

The following is a listing of the more common items to consider when specifying a mechanical adjustable-speed belt drive for a specific application:

1. Manufacturer's size designation of the drive
2. Range of speed variation and actual output speeds





**FIGURE 7** Mechanical adjustable-speed drive with pneumatic actuator for automatic speed changing (Reliance Electric)

3. Motor specifications: power rating, electric current (single or polyphase, frequency, and voltage), type of enclosure, and other special electric or mechanical modifications
4. Special drive output shaft extension
5. Type of control: handwheel, electric remote, mechanical automatic, pneumatic, and so on
6. Manufacturer's assembly configuration designation and type of mounting, whether standard floor type, trunnion, ceiling, sidewall, or flange
7. Accessory equipment, such as tachometer, magnetic brake
8. Power rating based on constant torque and maximum output speed
9. Type of case enclosure

---

# SECTION 6.3

---

# POWER TRANSMISSION DEVICES

---

## 6.3.1 PUMP COUPLINGS AND INTERMEDIATE SHAFTING

FRED K. LANDON  
DONALD B. CUTLER

### **COUPLING TYPES USED IN PUMP DRIVE SYSTEMS**

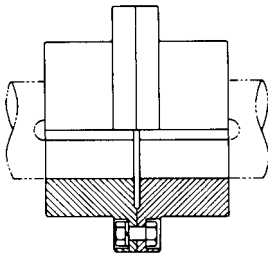
---

A coupling is used wherever there is a need to connect a prime mover to a piece of driven machinery. The principal purpose of a coupling is to transmit rotary motion and torque from one piece of equipment to another. Couplings may perform other secondary functions, such as accommodating misalignment between shafts, compensating for axial shaft movement, and helping to isolate vibration, heat, and electrical eddy currents from one shaft to another.

**Rigid Couplings** Rigid couplings are used to connect machines where it is desired to maintain shafts in precise alignment. They are also used where the rotor of one machine is used to support and position the other rotor in a drive train. Because a rigid coupling cannot accommodate misalignment between shafts, precise alignment of machinery is necessary when one is used.

**TYPES** There are two commonly used types of rigid couplings. One type consists of two flanged rigid members, each mounted on one of the connected shafts (Figure 1). The flanges are provided with a number of bolt holes for the purpose of connecting the two half-couplings. Through proper design and installation of the coupling, it is possible to transmit the torque load entirely through friction from one flange to the other, which assures that the flange bolts do not experience a shearing stress. This type of arrangement is especially desirable for driving systems where torque oscillations occur, as it avoids subjecting the flange bolts to a shearing stress.

A second type of rigid coupling, known as the *split rigid*, is split along its horizontal centerline (Figure 2). The two halves are clamped together by a series of bolts arranged axially along the coupling. The rigid coupling and machine shafts may be equipped with conventional keyways, which are in turn fitted with keys to transmit the torque load, or in



**FIGURE 1** Flanged rigid coupling (Kop-Flex)



**FIGURE 2** Split rigid coupling (Dodge Manufacturing Division, Reliance Electric)

certain cases the frictional clamping force may be sufficient to permit transmitting the torque by means of friction between shaft and rigid coupling. This type of coupling is commonly used to connect sections of line shafting in a drive train.

A variation to the flanged rigid coupling is known as the adjustable rigid coupling (Figure 3). This coupling is designed along the lines of conventional rigid couplings, except that a threaded adjusting ring is placed between the two flanges. This ring engages a threaded extension on one of the shaft ends. By means of this ring, it is possible to position the pump shaft axially with respect to the driver.

**APPLICATIONS** A common application for rigid couplings in the pump industry is in vertical drives, where the prime mover (generally an electric motor) is positioned above the pump. In such cases, both machines can employ a common thrust bearing, which is generally located in the motor. The coupling flange bolts must be capable of transmitting any down thrust from the pump to the motor. In applications where the thrust from the pump is toward the motor, it is common practice to provide shoulders on the shafts to transmit the axial force.

Many pump drive systems require a rigid coupling that is capable of providing axial adjustment to compensate for wear in the pump impeller or impellers. The adjustable rigid coupling is used for this purpose. The threaded adjusting ring attached to a mating threaded extension of the pump shaft permits vertical positioning of the impeller or impellers. The hub, which is mounted on the pump shaft, is equipped with a clearance fit and feathered key that permit the hub to slide with respect to the shaft. The load capacity of a coupling of this type is generally limited by the pressure on the pump shaft key because there is no possibility of load being transmitted by interference fit.

A few words of caution should be noted about the use of rigid couplings. First, precise alignment of machine bearings is absolute necessary because there is no flexibility in the coupling to accommodate misalignment between shafts. Secondly, accuracy of manufacture is extremely important. The coupling surfaces that interface between driving and driven shafts must be manufactured with high degrees of concentricity and squareness, to avoid the transmittal of eccentric motion from one machine to the other.

**Flexible Couplings** Flexible couplings accomplish the primary purpose of any coupling; that is, to transmit a driving torque between prime mover and driven machine. In addition, they perform a second important function: they accommodate unavoidable misalignment between shafts. A proliferation of designs exists for flexible couplings, which may be classified into two types: mechanically flexible and materially flexible.

**MECHANICALLY FLEXIBLE COUPLINGS** Mechanically flexible couplings compensate for misalignment between two connected shafts by means of clearances incorporated in the design of the coupling. The most commonly used type of mechanically flexible coupling is the gear, or dental, coupling (Figure 4). This coupling essentially consists of two pair of clearance fit splines. In the most common configuration, the two machine shafts are

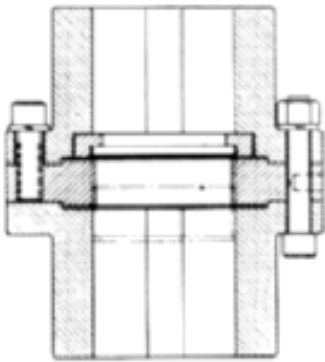


FIGURE 3 Adjustable flanged rigid coupling (Kop-Flex)



FIGURE 4 Gear-type mechanically flexible coupling (Kop-Flex)

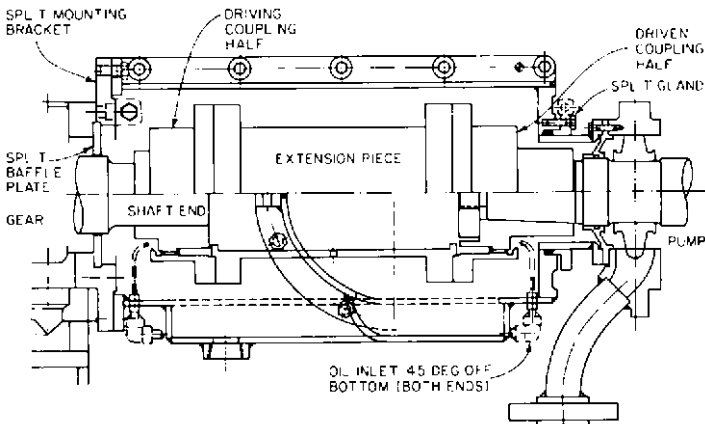


FIGURE 5 Continuously lubricated coupling (Kop-Flex)

equipped with hub members having external splines cut integrally on the hubs. The two hubs are connected by a sleeve member having mating internal gear teeth. Backlash is intentionally built into the spline connection, and it is this backlash that compensates for shaft misalignment. Sliding motion occurs in a coupling of this type, and so a supply of clean lubricant (grease or oil, depending on the design) is necessary to prevent wear of the rubbing surfaces.

If operation cannot be interrupted to lubricate the couplings, constantly lubricated couplings are used, as shown in Figure 5. These consist of an oiltight enclosure bolted at one end to the stationary portion of either the driving or driven piece of equipment. The other end of the enclosure has a slip fit inside a cover that is bolted to the other piece of equipment. Some form of packing is used to prevent loss of lubricant at the slip joint. Oil under pressure is brought through the enclosure and impinges upon the meshing gear teeth of the coupling, the excess being collected at the bottom of the enclosure and returned to the oil reservoir.

A second type of mechanically flexible coupling that sees wide usage, especially in low-cost drive systems, is known as the roller-chain flexible coupling (Figure 6). This coupling

employs two sprocket-like members mounted one on each of the two machine shafts and connected by an annulus of roller chain. The clearance between sprocket and roller and, in some cases, the crowning of the rollers provide mechanical flexibility for misalignment. This type of coupling is generally limited to low-speed machinery.

**MATERIAL-FLEXIBLE COUPLINGS** These couplings rely on flexing of the coupling element to compensate for shaft misalignment. The flexing element may be of any suitable material (metal, elastomer, or plastic) that has sufficient resistance to fatigue failure to provide acceptable life. Some materials, such as steel, have a finite fatigue limit. A coupling made of such material must be operated under conditions of load and misalignment that assure that the stress developed in the coupling element is within that limit. Other materials, such as elastomers, generally do not have a well-defined fatigue limit. In these cases, however, heat developed in the material when the coupling flexes can cause failure if excessive.

One type of material-flexible coupling is the metal-disk coupling (Figure 7). This coupling consists of two sets of thin sheet-metal disks bolted to the driving and driven hub members. Each set of disks is made up of a number of thin laminations that are individually flexible and compensate for shaft misalignment by means of this flexibility. These disks may be stacked together as required to obtain the desired torque transmission capability. This type of coupling requires no lubrication; however, alignment of the equipment must be maintained within acceptable limits so as not to exceed the fatigue limit of the material.

Another example of an all-metal material-flexible coupling is the flexible diaphragm coupling, shown in Figure 8. This coupling is similar in function to the metal-disk coupling in that the disk flexes to accommodate misalignment. However, the diaphragm type consists of a single element with a hyperbolic contour that is designed to produce uniform stress in the member from inner to outer diameter. By more efficiently utilizing the material, the weight is reduced correspondingly, thus making this coupling suitable for high-speed applications.

Material-flexible couplings employing elastomer materials are numerous and their designs are varied. By definition, an elastomer is a material that has a high degree of elasticity and resiliency and will return to its original shape after undergoing large-amplitude deformations. One example of an elastomer coupling is the pin-and-bushing coupling (Figure 9). This design comprises two flanged hub members, one mounted on each machine shaft. The flange of one hub is fitted with pins that extend axially toward the adjacent shaft. The other flange is equipped with rubber bushings, which generally have a metal



**FIGURE 6** Roller-chain mechanically flexible coupling (Dodge Division, Reliance Electric)



**FIGURE 7** Spacer metal disk coupling (Thomas Coupling Div./Rexnord)



**FIGURE 8** Diaphragm material-flexible coupling (Fluid Power Division, Bendix)



**FIGURE 9** Pin-and-bushing elastomer coupling (Ajax Flexible Coupling)



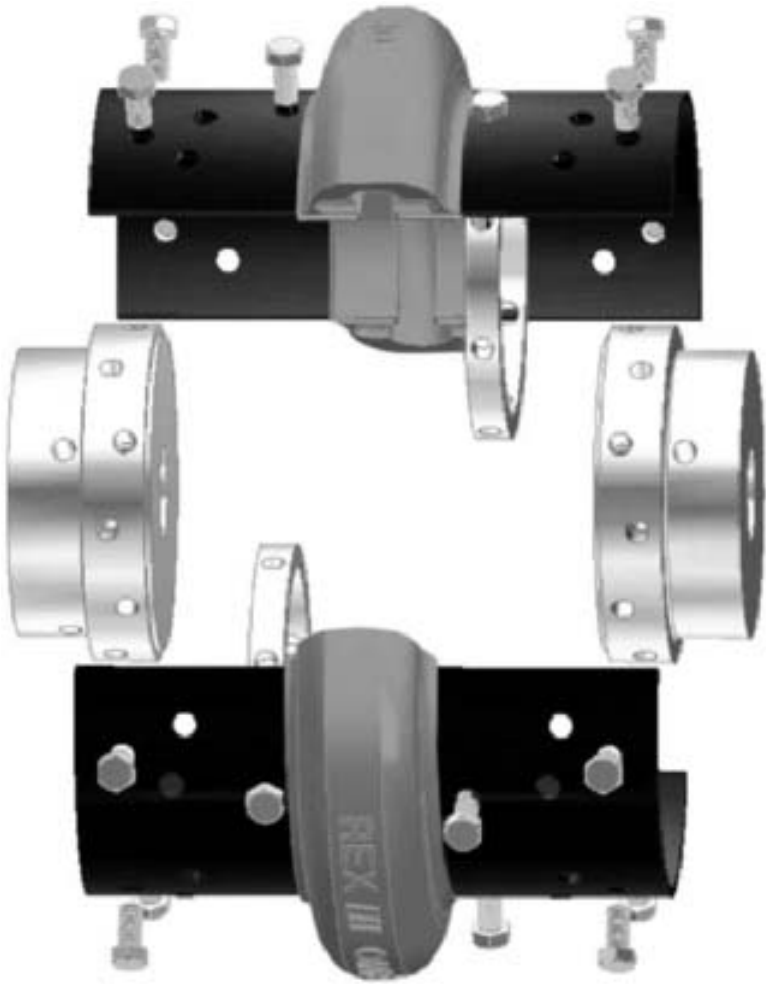
**FIGURE 10** Sleeve-type elastomer coupling (T B. Woods)

sleeve at the center. The pins fit into these sleeves and provide transmission of torque through the bushings. Because the bushings are made of flexible material, they can accept slight angularity or offset conditions between the two flanges.

A second group of elastomer couplings employs a sleeve-like element that is connected to a hub member on each shaft and transmits torque through shearing of the flexible element. The flexible element may be attached to the machine hubs by a number of different means: it may be chemically bonded, it may be mechanically connected by means of loose-fitting splines (Figure 10), or it may be clamped to the hubs and held in place by friction (Figure 11). Misalignment between shafts is accommodated through flexing of the elastomer sleeve.

A third group of couplings utilizes an elastomer member that is loaded in compression to transmit load from one shaft to the other. The elastomer material is placed loosely into cavities formed by members rigidly mounted onto the two shafts (Figure 12). Again, the elastomer material deflects to compensate for shaft misalignment, and is usually used when torsional damping is required.

Another type of elastomer coupling that is commonly used on low-power drive systems is the rubber jaw coupling (Figure 13). The heart of this coupling is a “spider” member, having a plurality (usually three) of segments extending radially from a central section. The



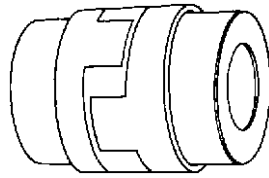
**FIGURE 11** Spacer elastomer coupling (Omega Coupling Div./Rexnord)

hubs, which are mounted on driving and driven shafts, each have a set of jaws corresponding to the number of spiders on the flexible element. The spider fits between the two sets of jaws and provides a flexible “cushion” between them. This cushion transmits the torque load as well as compensating for misalignment.

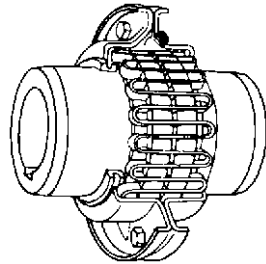
**SPRING-GRID COUPLING** There is a type of commercially available flexible coupling that combines the characteristics of mechanically flexible and material-flexible couplings. This is the spring-grid coupling (Figure 14). This design has two hubs, one mounted on each machine shaft. Each hub has a raised portion on which toothlike slots are cut. A spring steel grid member is fitted, or woven, between the slots on the two hubs. The grid element can slide in the slots to accommodate shaft misalignment and flexes like a leaf spring to transmit torque from one machine to the other. Unlike most material-flexible couplings, this design requires periodic lubrication to prevent excessive wear of the grid member.



**FIGURE 12** Compression-loaded, loosely fitted elastomer coupling (Kop-Flex)



**FIGURE 13** Rubber jaw coupling (Lovejoy)



**FIGURE 14** Spring-grid coupling (Falk Division, Sundstrand Corp.)

**APPLICATIONS** The type of flexible coupling most suitable for a particular application depends upon a number of factors, including power, speed of rotation, shaft separation, amount of misalignment, cost, and reliability. In the design of a system, it is the goal of the designer to use the least expensive coupling that will do the job. In low-cost systems, cost alone may be the most important criterion, and the least expensive coupling that transmits the rated power and accepts some small degree of misalignment is generally the choice, albeit at some sacrifice of reliability and durability. On the other hand, high-power, high-speed machinery generally represents a critical piece of equipment for a power station, sewage plant, or other vital process, and in these cases a coupling should be selected that will not compromise the overall reliability of the system.

Low-power pumps (up to about 200 hp, 150 kW) driven by electric motors can usually be coupled successfully by any of the couplings described here. Selection procedures vary from manufacturer to manufacturer, but generally the following data are required: power rating, speed, anticipated misalignment, and type of pump (reciprocating, vane, centrifugal, and so on).

Pumps of the same power range are very often driven by reciprocating engines (diesel, gasoline, natural gas). This is quite common in remote areas, such as at pipeline pumping stations, where a source of electric power is not available. Because this type of prime mover produces a pulsating type of power, it is often necessary to perform a torsional vibration analysis of the drive system to ensure that the normal operating speed is well removed from a speed that may produce a torsional resonant vibration. Such an analysis requires that the torsional stiffness of the coupling be known. It is quite often possible to tune the drive system to avoid operating at a resonant condition by selecting the proper coupling stiffness. The selection data required for a system of this type are the same as listed above. Most coupling manufacturers will, however, assign a higher service factor to an application involving a reciprocating prime mover, to compensate for fatigue effects due to torque fluctuations. In addition, the remote location of many engine-driven pumps indicates a special need to ensure a high degree of reliability of the system.

Another commonly employed prime mover is a steam turbine. These machines, which range from about 100 hp (75 kW) to well over 50,000 hp (37,000 kW) for pump drives, operate very efficiently and economically, providing there is a source of steam



available at the installation. Any flexible coupling employed on a machine driven by a steam turbine must be capable of accepting the thermal gradient at the turbine shaft and must also accommodate the axial growths of the turbine shaft as it warms up to operating speed.

Steam turbines are generally high-speed machines (4,000 to as high as 10,000 to 15,000 rpm in some cases) and as such require a relatively high degree of system balance to avoid critical vibration. Elastomer couplings have occasionally been applied successfully to steam turbine drives, but because of the high speeds involved, all-metal couplings are usually employed. The metal coupling most commonly used on this type of drive is the gear (mechanically flexible) design. High-speed machinery requires that the weight of rotating components be minimized to decrease shaft deflections and hence increase the lateral critical speed of the system. The gear coupling is an efficient design for transmitting large amounts of power at high speeds and with minimum weight. However, disk/diaphragm coupling designs that are light, flexible, and do not require lubrication are becoming more popular, especially for higher speed applications.

Where coupling weight and torsional stiffness are critical values to the overall system, special designs may be created that provide the specific values required for satisfactory system operation.

**BALANCE** For higher speed, higher power applications, coupling balance (or residual unbalance) is an important factor to consider. Elastomeric couplings may have a considerable amount of residual unbalance because of their construction, and they don't lend themselves to balancing. The amount of residual unbalance in metal couplings may be controlled largely by the level of precision to which they are manufactured. When pumps operate at speeds exceeding four-pole motor speeds and low equipment vibration levels are critical to service life, elastomeric couplings may not be a good choice. Such requirements are important to certain pump types, like those required for API Standard 610: "Centrifugal Pumps for Refinery, Heavy Duty Chemical, and Gas Industry Services." For more information on coupling manufacturing and balance classes and requirements, the reader is referred to the API and AGMA standards listed at the end of this section.

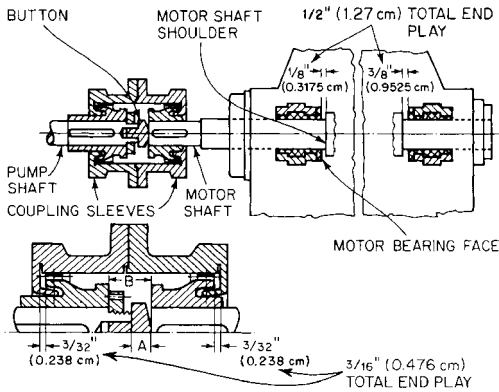
**LIMITED END FLOAT** Many horizontal motor-driven pump systems utilize motors that are equipped with journal, or sleeve-type, bearings. These bearings are intended only to absorb the transient thrust created by the motor rotor during acceleration and deceleration. The coupling for this type of drive should be equipped with suitable provisions for limiting the axial float of the motor rotor to some fraction of its total float. This may be done by positioning the motor in the center of its axial travel and then employing a coupling having a total float that is less than the float of the motor. Any motor thrust is taken by the pump bearing. Gear coupling total float can be limited by inserting a button between shaft ends, as shown in Figure 15. This type of coupling prevents the motor rotor from ever contacting the thrust shoulders on the shaft bearings. Certain types of elastomer and disk couplings having inherent float-restricting characteristics provide centering without any additional modifications (Figures 16 and 17).

**VERTICAL OPERATIONS** As previously noted, rigid couplings are commonly used on vertical-drive systems where the system characteristics warrant such a coupling. However, many vertical-drive systems require a flexible coupling to accommodate shaft misalignment. It is generally possible to use a nonlubricated coupling, such as one of the many elastomer designs, in a vertical position without modification, provided the shafts are supported in their own bearings and the coupling does not have to transmit a thrust force. Lubricated designs, such as the gear and spring-grid types, usually require some modification to make certain that lubricant is retained in both halves of the coupling.

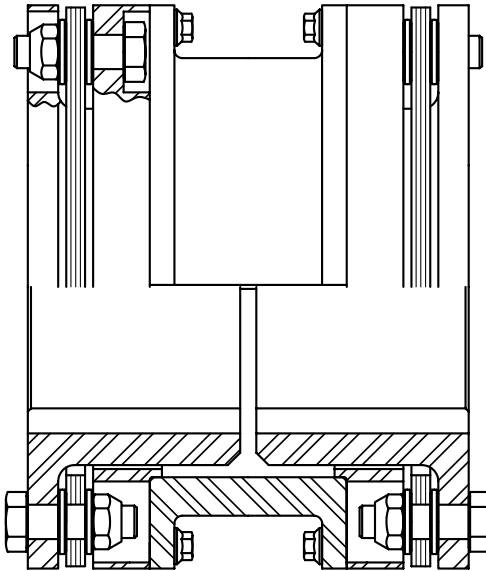
## **PUMP DRIVE SHAFT SYSTEMS**

---

Pump drive system arrangements may be classified in one of two categories: those that are close-coupled, having a shaft separation of a fraction of an inch (not to be confused with



**FIGURE 15** Motor-driven coupling end float limited by insertion of button between shaft end (Flowserve Corporation)



**FIGURE 16** Metal disk coupling with flanged, tubular spacer (Thomas Coupling Div/Rexnord)

integral motor pumps not having a flexible coupling) and those that, for one or more reasons, have the prime mover located a substantial distance from the pump. These latter types of systems require a modification to the basic flexible coupling designs previously described.

**Spacers** One means of accommodating shaft separation in excess of the normal amount provided in a standard coupling is to employ a flanged tubular spacer between the two coupling halves (Figure 18). These components are lightweight and are commonly used with end-suction pumps, where it is possible to remove the pump impeller while the pump

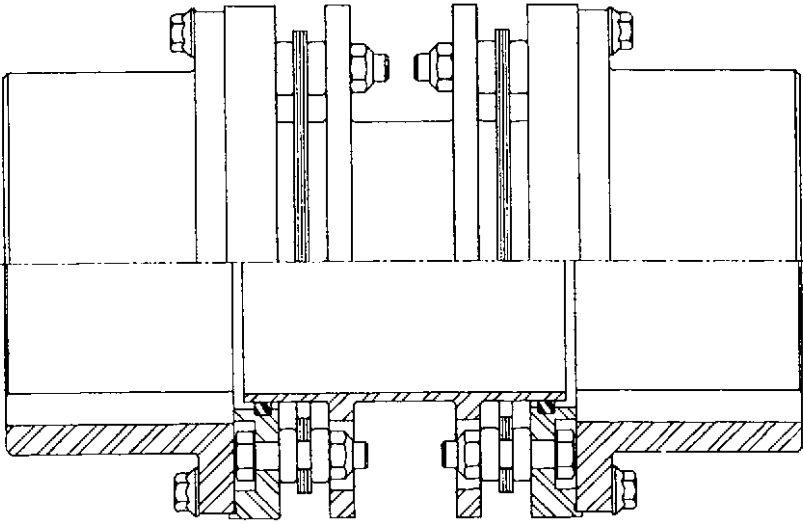


FIGURE 17 Vertical double-engagement gear coupling (Koppers)

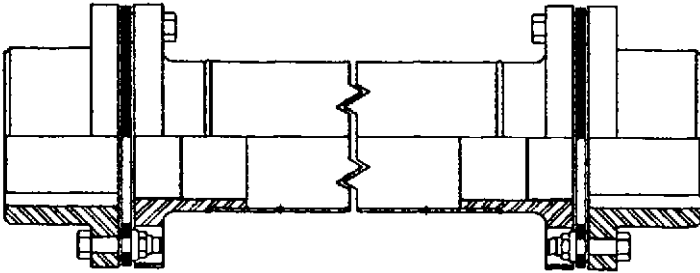
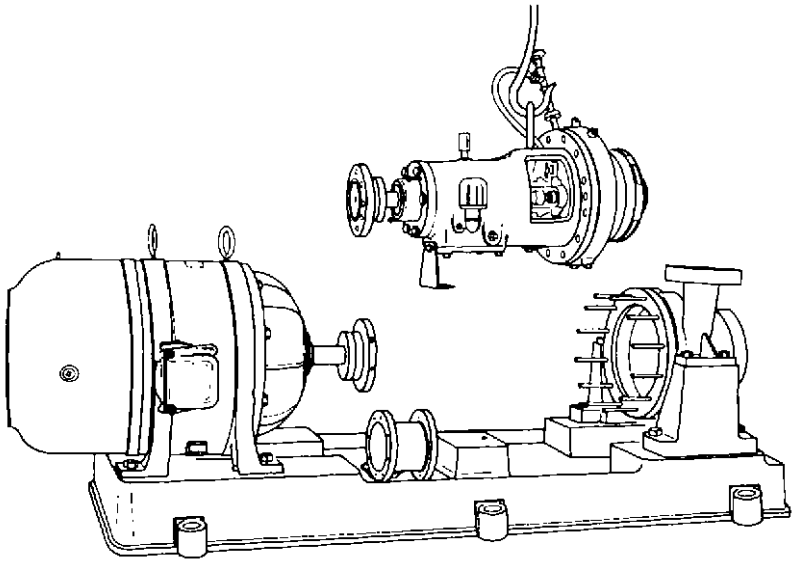


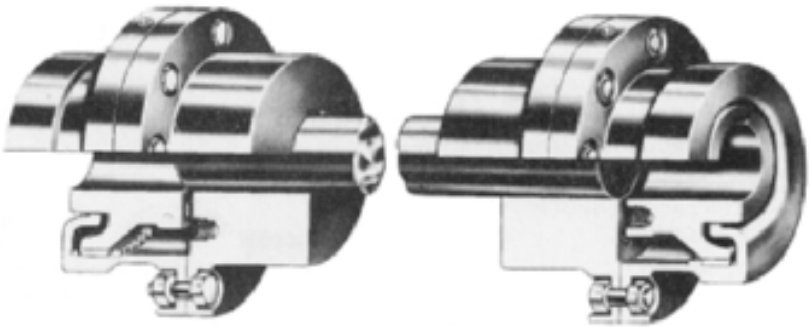
FIGURE 18 Tubular spacer coupling (Koppers).

housing and piping, as well as the prime mover, remain in place (Figure 19). For high-speed drive systems, a lightweight spacer is usually the only practical means of achieving the goal. This spacer may be used to tune the system torsionally (as previously discussed) by varying the body diameter and wall thickness. Spacers can be manufactured in lengths up to several feet, but the cost generally restricts its usage to shorter lengths, except where no other means is suitable.

**Floating Shafts** Floating shaft couplings have a purpose similar to that of spacer couplings; namely, to connect two widely separated shafts. The basic difference is in the construction of the component. Whereas spacers are normally made with the body having an integrally formed flange to connect the two coupling halves, a floating shaft usually is made by attaching a flange to a piece of solid or tubular shafting by means of mechanical keys or by welding (Figure 20). This type of construction is generally less expensive than a one-piece spacer, especially when very large shaft separations must be spanned. Graphite composite center members are also being used. This material has the advantage of being much lighter and stiffer than standard metal components, allowing longer spans between bearing supports without adding mass.



**FIGURE 19** Spacer coupling enables end-suction pump to be dismantled without moving piping, pump casing, or driver (Worthington Pump).



**FIGURE 20** Section of floating shaft and couplings (Kop-Flex)

Floating shaft arrangements are widely used on horizontal pump applications of all types and are especially common on vertical pump applications, such as in water pumping and sewage treatment stations. In these latter applications, the pump may be submerged in a pit usually 30 to 50 ft (9 to 15 m) below ground level, whereas the motor (to prevent damage during flooding) is mounted at ground level. Settings as deep as 100 ft (30 m) have been constructed. Such systems require long floating shafts, which are generally made in sections and supported by line bearings at intermediate supports or floors.

**Rigid Shafts** Vertical centrifugal pumps can be designed to contain their own thrust and line bearings. These pumps employ a flexible coupling at the pump shaft. When vertical intermediate shafting is used, the shaft need be designed only to transmit torque. Some pumps are designed to contain only a single line bearing. These pumps require a rigid coupling at the pump shaft so axial thrust can be carried by the thrust bearing in

the driver or gear located above. The constructions of a single oil-lubricated line-bearing pump is shown in Figure 109 of Subsection 2.2.1. In order to carry thrust, the drive shaft, if made in sections, must use rigid intermediate couplings and the coupling at the driver or gear must also be rigid. Intermediate bearings used with rigid shafting must be designed to provide only lateral support, thereby assuring that all the axial thrust is carried by the driver or gear. An intermediate oil-lubricated sleeve-type guide bearing is shown in Figure 108 of Subsection 2.2.1. Pump and intermediate shaft sleeve guide bearings can be either grease- or oil-lubricated, and they can also be antifriction if preferred.

A rigid intermediate shaft connected to a pump provided with a rigid coupling must be designed to carry its own weight, the axial thrust from the pump, and a bending load. Volute-type centrifugal pumps produce a radial reaction on the pump shaft that in turn is transmitted to the vertical shafting through the rigid pump coupling. Intermediate bearings then act as line bearings. The bearing supports must also be designed to resist this bending force. The pump shaft and bearing, intermediate shafts and line bearings, and the driver or gear shaft and bearings must be treated as a single shaft supported at each bearing when analyzing the critical speed of the entire rotor system. If the intermediate line bearing supports are assumed to be nodes in the critical speed calculation, these supports must be absolutely rigid. The supplier of the shafting should, however, confirm what flexibility will be allowed at these supports and give the design forces. The support for the guide bearings must also be designed not to have a natural frequency of vibration within the operating speed range of the pump.

**Flexible Drive Shafts** Universal joints with tubular shafting (Figure 21) can be substituted for flexible couplings whenever it is necessary to (a) eliminate the need for critical alignment, (b) provide wider latitude in placement of pump and driver, and (c) permit large amounts of relative motion between pump and driver. This type of shafting can be used horizontally as well as vertically to provide a short spacer arrangement or a large separation between pump and driver, such as that required for deep settings (Figure 22).

Flanges are furnished to fit pump and driver shafts to the universal joints, which are splined to allow movement of the shaft. An intermediate steady bearing is required at each joint, which must also support the weight of a section of shafting (Figure 23). Because of the spline, pump thrust cannot be taken by the driver, and it is necessary to use a combination pump thrust and line bearing. Because of the universal joint, the intermediate bearing or bearings take no radial load from the pumps and therefore act only as a steady bearing or bearings for the shaft.

The shaft must be selected to transmit the required torque and be of a length and diameter that will have a critical speed well removed from the operating speed range of the pump. The support for the guide bearing must not have a natural frequency of vibration within the speed range. Shafts of this type are often pre-engineered and stocked. Selection charts are available from the manufacturer to make a proper size and length selection. Standard tubular, flexible drive shafts have limited torque-carrying capacity.

### Design Criteria

**TORSIONAL STRESS** The torsional stress in the shafting may be calculated by the following equations:

$$S_s = \frac{16T}{\pi D_o^3} \quad \text{for solid shafting}$$

$$S_s = \frac{16T}{\pi D_o^3 \left(1 - \frac{D^4}{D_o^4}\right)} \quad \text{for tubular shafting}$$

where  $S_s$  = torsional shear stress, lb/in<sup>2</sup> (N/m<sup>2</sup>)

$T$  = transmitted torque, in · lb (N · m)



**FIGURE 21** Tubular intermediate shafting and universal units (H. S. Watson)



**FIGURE 22** Sections of flexible shafts and intermediate guide bearings used to transmit torque from motor located above flood elevation to pump located below ground (Flowsolve Corporation)

$D_o$  = shaft outer diameter, in (m)

$D$  = shaft inner diameter (tubular shaft only), in (m)

The allowable shear stress depends upon the material being used and whether it is subjected to other loads, such as bending or compression. The design safety factor on the shafting should be equal to or greater than those of the other components in the drive train.

**CRITICAL SPEED** The critical speed of a drive shaft is determined by the deflection, or “sag,” of the shaft in a horizontal position under its own weight. The less the sag, the higher the critical speed. In practical terms, a long, slender shaft will have a low critical speed and a short, large-diameter shaft will have a very high critical speed. The deflection of a simply supported shaft is calculated as follows:

$$y = \frac{5wL^4}{384EI} = \text{shaft deflection, in (m)}$$

noting that

$$I = \frac{\pi D_o^4}{64} \quad \text{for solid shafting}$$

$$I = \frac{\pi(D_o^4 - D^4)}{64} \quad \text{for tubular shafting}$$

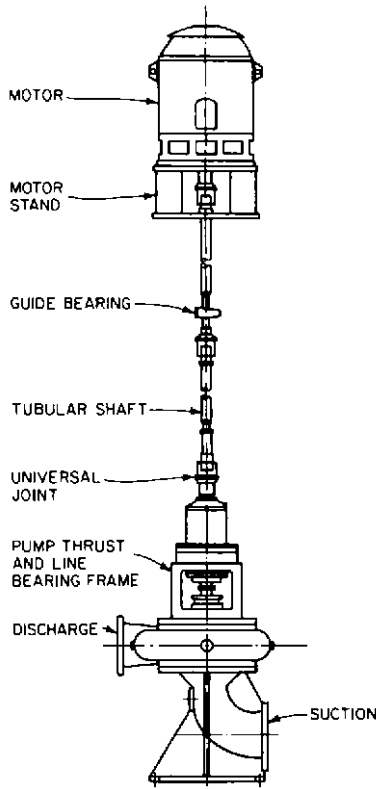


FIGURE 23 Vertical pump with flexible shafting (Flowserve Corporation)

where  $w$  = weight (force) of shaft per unit length, lb/in ( $N/m$ )

$L$  = length between bearing supports, in (m)

$E$  = Young's modulus, lb/in<sup>2</sup> ( $N/m^2$ )

$I$  = moment of inertia, in<sup>4</sup> ( $m^4$ )

Knowing the natural deflection of the shaft, it is possible to calculate the first critical speed from the equation:

$$N_{\text{crit}} = 187.7 \sqrt{\frac{1}{y \text{ (in inches)}}} = 946 \sqrt{\frac{1}{y \text{ (in millimeters)}}}$$

which expresses critical speed directly in revolutions per minute of the rotating shaft.

In practice, the critical speed should be placed well away from the operating speed of the shaft. Actual operating conditions, such as imbalance and clearance in bearings and couplings, tend to reduce the critical speed from its theoretical value. The designer has several options from which to choose to attain the desired critical speed: (1) vary the shaft diameter, (2) use tubular shafting to increase stiffness and reduce deflection, and (3) vary the bearing span.

Varying the diameter of the shaft has a dramatic effect on shaft deflection because the deflection decreases inversely with the cube of the diameter. The weight of the shaft will

increase proportionately to the square of the diameter and may consequently impose excessive loads on hearings. When this is the case, tubular shafting may be substituted for solid shafting. The ratio  $l/w$  is much higher for a tubular shaft than for a solid shaft of the same diameter, so the shaft deflection is again reduced and critical speed increased.

The bearing span may be varied when the size and weight of a single length is broken into sections, with a single engagement coupling used to connect each section and acting as a hinge joint. A self-aligning bearing is placed on each section immediately adjacent to the coupling. Each section may then be treated as an individual shaft, which will result in a substantial reduction in shaft size. The rigidity of the support at each hearing must be taken into consideration when calculating the critical speed of the shaft.

*Dynamic Balance* Drive systems that operate at high speeds and connect two widely separated shafts must be given special consideration with regard to dynamic imbalance. Care must be taken to ensure that the long, slender shaft used in such systems is not bent, either in manufacture or in installation. These systems quite often require shafting that has been dynamically balanced after manufacture to compensate for these normal errors.

## REFERENCES AND FURTHER READING

---

1. American Gear Manufacturers Association, ANSI/AGMA 9000. "Flexible Couplings—Potential Unbalance Classification." 1500 King Street, Suite 201, Alexandria, VA, 22314.
2. American Petroleum Institute Standard 610. "Centrifugal Pumps for Refinery, Heavy Duty Chemical, and Gas Industry Services." 8th ed., 1220 L Street, Washington, DC 20005, 1995.
3. American Petroleum Institute Standard 671. "Special Purpose Couplings for Petroleum, Chemical, and Gas Industry Services." 3rd ed., 1220 L Street, Washington, DC 20005, October, 1998.



# 6.3.2 HYDRAULIC PUMP AND MOTOR POWER TRANSMISSION SYSTEMS

DAVID ELLER

The use of fluid (hydraulic pump and motor) power transmission systems to drive water pumps is a relatively recent development. The first units of any size were first marketed in the late 1960s and early 1970s and were utilized primarily for construction dewatering purposes because they can be driven by diesel engines or electric motors located well away from construction site cave-ins without the inconveniences of priming and suction hoses and with no limitation on suction lift or capacity (Figure 1).

## **COMPONENTS**

---

A typical unit consists of a submersible axial-flow water pump with a hydraulic motor mounted in the pump bowl (Figure 2). The thrust bearings, shaft, and hydraulic motor are all sealed to operate under water. The hydraulic motor is driven by oil fed from a hydraulic pump under a pressure of approximately 2500 lb/in<sup>2</sup> (170 bar<sup>1</sup>). Water flowing past the hydraulic motor acts as a heat exchanger and keeps the system cool. Plumbing extends from the hydraulic motor out through the pump bowl and connects to the hydraulic oil conduits leading to the hydraulic pump driver. Quick-coupling hose connections are generally supplied on each end of the hydraulic hoses. The quick couplings contain spring-loaded ball valves that prevent the oil from leaking from either side when the couplings are disconnected (Figure 3).

The hydraulic pump is driven by the prime mover, which is generally a diesel engine or electric motor. The hydraulic conduits may be steel-reinforced rubber hoses or steel pipe or a combination of both (Figure 4). Sometimes it is desirable to utilize a combination of steel pipe and flexible hose as the conduits. This is particularly true when the drive units

<sup>1</sup>1 bar = 10<sup>5</sup> Pa.

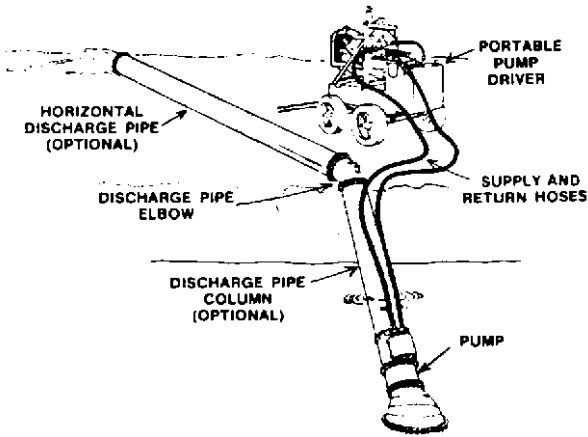


FIGURE 1 Typical portable hydraulically driven water pump with diesel prime mover (M & W Pump)

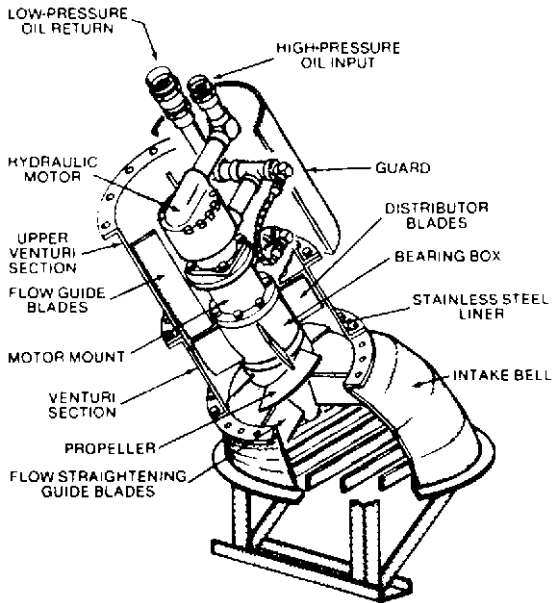


FIGURE 2 Interior of a hydraulically driven axial-flow water pump (M & W Pump U.S. Patent No. 3, 907, 463, other patents pending)

are to be located a considerable distance from the water pump. When steel pipe is used, it is highly desirable to weld all joints. After welding, the pipes should be thoroughly cleaned and tested up to maximum expected operating pressures and inspected for leaks. The pipes should then be painted with an asphalt-base enamel or epoxy, depending upon the surrounding environment.

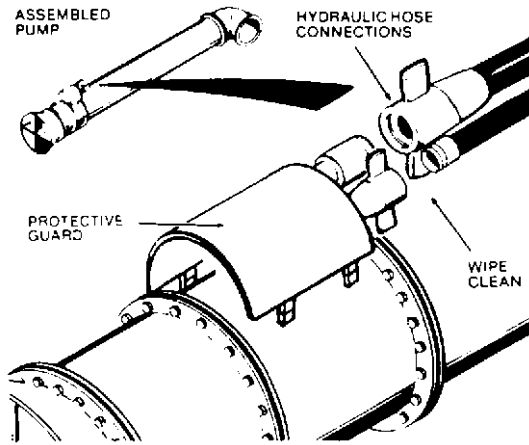


FIGURE 3 Quick couplings are used to fasten hydraulic hoses to the water pump

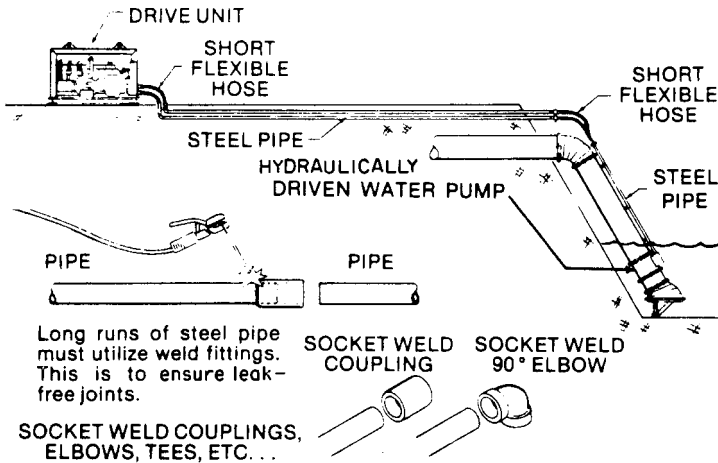


FIGURE 4 For permanent installation, steel pipes with welded joints are generally used for the hydraulic oil conduits instead of hoses.

Hydraulic pump and motor drives can be adapted to centrifugal volute pumps. Figure 5 illustrates a portable nonclogging-impeller trash or sewage pump so driven.

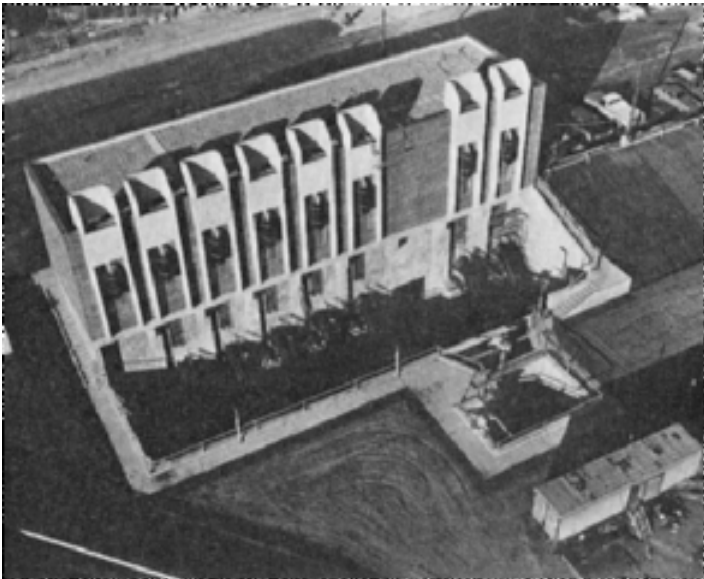
## ADVANTAGES

Although the original users of hydraulically driven water pumps were contractors, farmers, and open pit miners using mostly portable pumps, the system described here offers the advantage of permanent pump stations, such as might be used for municipal storm drainage (Figure 6) or massive irrigation or drainage works.

The system is very simple. The power source can be located close to the pump or in a more accessible or protected area. Other advantages include the ability to vary the speed



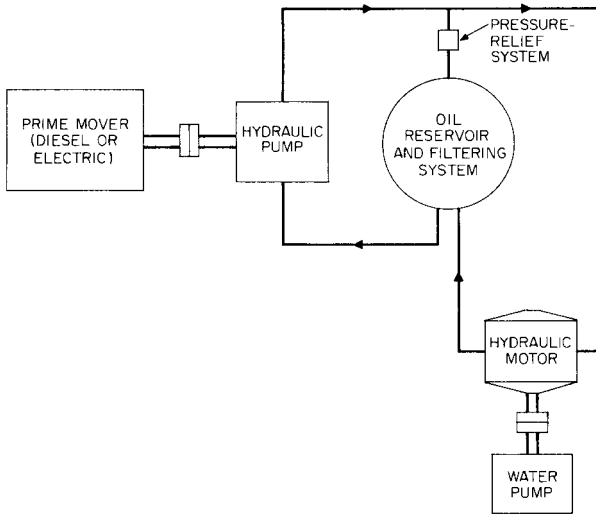
**FIGURE 5** Portable centrifugal volute trash pump driven by hydraulic motor (M & W Pump)



**FIGURE 6** A 350,000-gpm (79,500-m<sup>3</sup>/h) municipal pump station for combination storm drainage and final sewage effluent (M & W Pump)



**FIGURE 7** Five 42-in (107-cm) double-staged hydraulically driven water pumps with design flows automatically varying from 0 to 50,000 gpm (0 to 11,550 m<sup>3</sup>/h) (M & W Pump)



**FIGURE 8** Hydraulic drives are much simpler than other types of electromechanical equipment and provide a wide speed range, variable-speed and reversing capability, and shock resistance at a relatively low cost.

of the water pump by regulating the amount of hydraulic oil sent to the motor, the ease of automation for automatic or remote control, and safety because there is no high-voltage electricity in the water (Figures 7 and 8).

### **FIXED VERSUS VARIABLE FLOWS**

A fixed displacement hydraulic pump is used to drive the fixed-displacement hydraulic motor when a fixed water pump flow is desired. The drive shaft of a fixed-displacement vane pump (see Figure 9) is keyed to a rotor and revolves with it. Rectangular vanes fit into slots in the rotor. As the rotor turns, the vanes are forced out by centrifugal force to

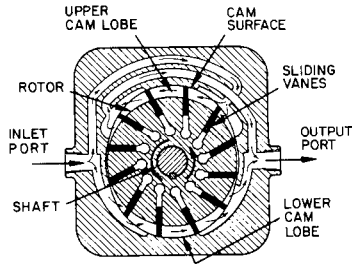


FIGURE 9 Principle of fixed-displacement balanced-vane pump

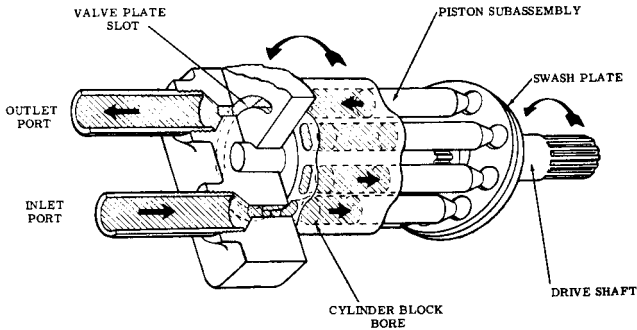


FIGURE 10 Principle of variable-displacement piston pump

make continuous contact with the cam surface. Because of the kidney shape of the cam surface, the space between a vane passing top dead center and the vane ahead of it starts closing down, increasing pressure and forcing oil out through the outlet port. Simultaneously, the vanes on the pump inlet side are passing through the cam kidney-shaped area, which is increasing in size, thus creating a vacuum that pulls oil in through the pump inlet.

When it is desirable (as for final sewage effluent pumping), water pump flow rate can be easily varied through a large range by regulating the amount of oil going to the hydraulic motor in the water pump bowl. Because the hydraulic motor has a fixed displacement, its speed is a direct function of the amount of oil supplied to it by the hydraulic pump connected to the prime mover. Assuming a constant-speed prime mover, the rate of oil flow can be changed easily by utilizing a variable-displacement piston hydraulic pump (Figure 10). In this type of pump, the pistons are moved into and out of the cylinder block by a swashplate rotating cam whose angle can be changed either manually or automatically. When the cam is set at zero angle, the piston does not move and no oil is pumped. As the cam angle is increased, the pistons begin to reciprocate and oil is pumped. The amount of oil pumped is directly related to the angle of the swashplate. For automatic systems, the swashplate angle can be regulated by a servo-control valve attached to the hydraulic pump. This valve is simply an apparatus that converts an electric signal to a mechanical force. A typical system would utilize a 0- to 20-mA signal coming from a sensor in the pump sump.

The sensor could be a sonic, air bubbler, or float device measuring the wet-well sump level and sending a proportional electric signal back to the servo-control valve on the hydraulic pump. If the sump level is rising, for instance, the electric signal may increase, which would cause the servo to stroke the hydraulic pump swashplate to a greater angle, increasing the amount of oil being pumped. This in turn would speed up the hydraulic motor and the water pump propeller, and the water pump flow would increase. Thus a rel-

atively small water-pump sump can be utilized, and pumped water outflows can be regulated to match highly varying gravity inflows.

## EFFICIENCY

The main criticism of hydraulic power transmission systems for water pumps is that power is lost through the hydraulic system. There is obviously a power loss in the hydraulic pump, the hydraulic motor, and the plumbing. However, when evaluating efficiencies against those of other types of power transmission systems, such as gears, belts and pulleys, and direct-connected shafts, it is important to make meaningful comparisons.

Water pump manufacturers typically publish performance curves for their wet-pit pump bowls *only*, and these curves do not include power losses for *any* type of power transmission system. This is done because the pump manufacturer does not know the shaft lengths for all possible extended-shaft pumps. Therefore, there is no way the manufacturer can include the losses for the shaft, bushing and bearing supports, couplings, and other transmission parts. Consequently, a user must add to the evaluation the losses resulting from the extended shafting and other transmission parts.

For example, a typical extended-shaft pump may have a column shaft 30 ft (9 m) long. An additional power requirement of 10 to 15% above that of the pump alone would not be unusual for an extended-shaft pump with a gear or belt drive. By comparison, a hydraulically powered pump would typically have a power transmission loss of 20 to 25%—or in other words, would require 10 to 15% more power than an equivalent extended-shaft pump. Thus, a hydraulically powered pump may require, for example, a 30-hp (22-kW) motor rather than a 25-hp (19-kW) motor or diesel prime mover. However, the additional cost of this larger motor should be weighed against the savings in civil works costs and engineering and installation time and the savings resulting from the versatility and automatic operation possible with the hydraulic system.

## AVAILABLE SIZES

Hydraulic pump and motor transmission systems are available for almost any speed output, from 100 to 3000 rpm for power outputs up to 500 hp (370 kW). For larger power drives, speed selection is more limited.

Table 1 illustrates readily available standard pump and hydraulic drive sizes from one manufacturer.

**TABLE 1** Standard pump sizes readily available with hydraulic drives

Discharge diameter, in (cm)	Capacity range, gpm (m <sup>3</sup> /h)		Total head range, ft (m) <sup>a</sup>
4 (10)	475–1,025	(110–280)	8–10 (2–12)
6 (14)	700–1,450	(160–330)	18–50 (5–15)
8 (20)	1,400–2,300	(820–520)	5–23 (1.5–7)
12 (89)	2,500–4,000	(570–910)	5–45 (1.5–14)
16 (41)	4,000–8,000	(910–1,800)	5–28 (1.5–7)
18 (46)	5,000–9,000	(1,100–2,000)	18–45 (5–14)
20 (51)	7,000–12,000	(1,600–2,700)	5–20 (1.5–6)
24 (61)	12,000–17,000	(2,700–3,900)	5–22 (1.5–7)
30 (76)	23,000–27,000	(5,200–6,100)	5–22 (1.5–7)
36 (91)	24,000–35,000	(5,400–7,900)	5–19 (1.5–6)
42 (107)	45,000–53,000	(10,000–12,000)	5–16 (1.5–5)
60 (152)	100,000–120,000	(23,000–27,000)	5–16 (1.5–5)

<sup>a</sup>Most units can be double-staged to accomplish twice the heads shown.

**PUMP  
CONTROLS  
AND  
VALVES**

**W. O'Keefe**



## CONTROLS

---

Pump control in the broadest sense gives the pump user (1) the flow rate, pressure or liquid level desired, (2) protection for the pump and system against damage from the pumped liquid, and (3) administrative freedom in decisions on operations and maintenance.

**Control System Types** Pump control systems range in complexity from single hand-operated valves to highly advanced, automatic flow control or pump speed control systems. Pump type and drive type are factors in control system choice. For centrifugal pumps, either change of speed or change of valve setting can control the desired variable. For positive displacement pumps, whether reciprocating, rotary, screw, or other type, control is by change in speed, change in setting of bypass valve, or change in displacement. The last-mentioned method is found in metering and hydraulic drive pumps. Although this chapter considers only control systems having valves as final control elements, the sensing elements discussed also serve in pump speed control systems.

Pump control systems divide readily into two types: on-off and modulating. The on-off system provides only two conditions: a given flow (or pressure) value or a zero value. A valve is therefore either open or closed, and a pump driver is running or not. The modulating system, on the other hand, adjusts valve setting or speed to the needs of the moment. Either type of system can be automatic or manual.

**System Essentials** All control systems have

1. A sensing or measuring element
2. A means of comparing the measured value with a desired value
3. A final control element (a valve) to produce the needed change in the measured variable
4. An actuator to move the final control element to its desired position
5. Relaying or force-building means to enable a weak sensing signal to release enough force to power the actuator

The sensing or measuring element is often physically separated from the comparison and relaying means, which are usually housed together and called the *controller*. The actuator and valve are physically connected and may be at a distance from the controller.

In a very simple control action, such as one based on an administrative decision to shut down temporarily one of several small parallel pumps in service, some of the five essentials may be supplied by the operator who turns the valve handwheels and pushes the motor stop button. Nevertheless, the essentials must always be present in some form.

**EFFECT OF RATE OF CHANGE** The nature of the rate of change of the measured variable or desired value with time gives a convenient guideline in pump control. The chief types of change are

1. Slow change (practically steady state)
2. Sudden change from one steady state to another (either a nearly instantaneous step change or a high-rate ramp change)
3. Fluctuation at varying rates and in varying amounts

Slow change involves questions of the ability of the control system to hold the desired value accurately and not lag unnecessarily during the change. Equal accuracy when approaching the new value from above or below is also desired.

Sudden change involves additional questions of whether the system will be excited into amplification of some types of fluctuations and go totally out of control. Systems involving fluctuation changes are the most difficult to design and operate; such factors as the inertia of the control elements, amount of liquid in the system, and dynamic behavior of each element and of the elements together must be considered.

**OPEN-LOOP CONTROL** The simplest mode of automatic control is open-loop control, in which the pump speed (or displacement in some pump types) or the control valve setting is

adjusted to and held at a desired value calculated or calibrated to produce the required output of flow, level, or pressure. The calculation can result in a cam for the controller or positioner or a particular characterization of a valve plug. In operation, only the deviation of the input variable from its desired value is measured and the control system adjusts the input variable to eliminate the deviation. Because the output variable is not measured, a change in the conditions on which calculation or calibration was based will introduce output errors. Change of input variable can be done manually or by another control system. For example, a pump may be speeded up by a rheostat, or the air pressure to a valve actuator may be changed by changing a pneumatic pressure control valve setting. Open-loop systems are also called feedforward systems, in contrast to feedback, or closed-loop systems. Open-loop systems are stable, simple, and quick in response, but they tend to err as downstream conditions change.

**CLOSED-LOOP CONTROL** A closed-loop control system eliminates much of the error of the open-loop system. In the basic closed-loop, or feedback, system, the output variable is measured and the value compared with an arbitrary desired or set value. If the comparison reveals an error, the pump speed or control valve setting is changed to correct the error. Large-capacity water tanks or lag in the control system can introduce delays in establishment of the new output value, and the system can therefore overcorrect and oscillate back and forth unless design prevents this.

**ON-OFF CONTROL** The simplest closed-loop systems operate on-off between fixed limits, such as water level or pressure. The on-off action is at the extremes of a wide or narrow band that can be set at any point in the range. For example, a tank level control may work in an on-off band of 1 in (2.54 cm) or 10 in (25.4 cm) at any level in a tank that is 5 ft (1.5 m) deep.

**PROPORTIONAL CONTROL** This is the basic type of closed-loop control. Within a wide or narrow band of output variable values, the controller input, such as actuator air pressure, is proportional to the deviation from the set point, or desired value, at the band center. If the band is very narrow, for example, 1 in (2.54 cm) of level in a 60-in (1.5-m) tank, the controller will apply full air pressure to the valve actuator at a  $\frac{1}{2}$ -in (1.27-cm) deviation from the set level in one direction and minimum air pressure at a  $\frac{1}{2}$ -in (1.27-cm) deviation in the other direction. This is close to the effect of an on-off control. If the band is wider, say 20 in (50.8 cm) of level in the 60-in (1.5-m) tank, the air pressure will vary from minimum to full pressure over the 20-in (50.8-cm) band and the system will be less sensitive and apply less correction for a given small change in output variable. The lower sensitivity can make the system less likely to overshoot or hunt. Because a given controller output corresponds to every value of deviation from the set point, the simple proportional system will not come back to its set point if the output variable changes as a result of changed demand, such as for more water from the tank. The difference between set point and actual new equilibrium value of level is called *offset*. Narrowing the band will reduce the offset but may cause intolerable oscillations or hunting.

To improve response and stability and to achieve very high accuracy, however, several refinements may be needed. Addition of reset to a simple proportional controller will eliminate offset. This is the proportional-plus-reset or proportional-plus-integral system. In terms of the proportional band, reset means that the band is shifted in such a way as to produce slightly more correction and return the output variable back to what is desired. The reset feature may impair stability, however, because of the added control action.

Derivative action is an added refinement to improve stability and response. In this, the rate of change of the measured output variable is what determines the controller output. A step or sudden change in measured output variable will cause a momentary large increase in controller output that will initiate response. When the derivative action fades, the basic proportional-plus-reset action takes over to restore conditions.

The open-loop system, sensing a change in input variable and therefore giving rapid response, is exploited by adding it to the closed-loop system. An example of a feedforward-feedback system in pump flow control is the three-element boiler feedwater regulator.

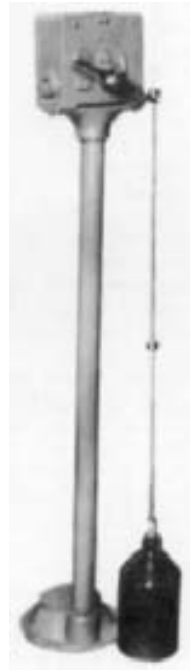
**Sensing and Measuring Elements** In automatic control of a pump, these elements detect values of and changes in liquid level, pressure, flow rate, chemical concentration, and temperature. The signal emitted by the element often needs amplification or conversion to another medium, which is done in a transducer. Air pressure to electric voltage or current and rotary motion to electric voltage are common transformations.

**LIQUID-LEVEL SENSORS** The simplest of several types of sensors is the float in the main tank (or boiler drum) or in a separate float chamber connected at top and bottom to the tank or drum (Figure 1). The float can be a pivoted type, with motion transmitted outside the chamber by a small-diameter rotating shaft or translational rod attached to the lever arm near its pivot to obtain mechanical advantage. A rod of the latter type can actuate the stem of a balanced valve to control liquid flow and thus liquid level in the supplied tank.

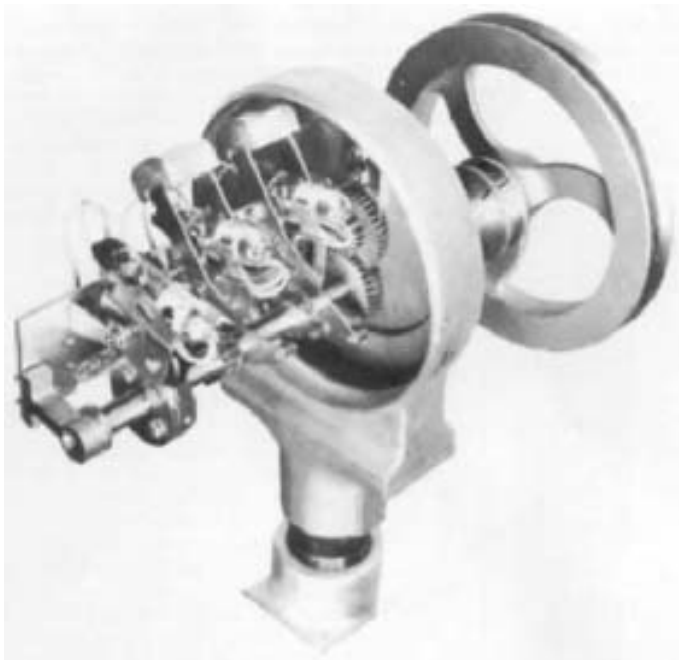
Floats on vertical rods can actuate switches outside and above the float chamber (Figure 2). Depths can vary from less than 1 to more than 50 ft (0.3 to 15 m), with rod guides often necessary at the greater depths. In some cases, the floats slide on the vertical rod at the desired control levels and trip the switch above. In a displacer-type arrangement for open tanks, a ceramic displacer is suspended from one end of a stainless steel tape that passes over a pulley and down again to a counterweight. The counterweight compensates for part of the ceramic displacer weight, so it floats in the liquid. The extended pulley shaft drives through a reducing gear to a shaft that carries mercury switches controlling as many as four circuits (Figure 3). The gearing allows the displacer to travel as far as 30 ft (9 m), with level adjustment between 2 and 27 ft (0.6 to 8 m). A weighted overcenter mechanism in the switches gives quick make and break.



**FIGURE 1** Low-water cutoff and alarm are purposes of this liquid level sensor (McDonnell & Miller).



**FIGURE 2** Adjustable tops on rod actuate lever arm to tilt mercury switches as float moves (Autocon Industries)



**FIGURE 3** Mercury switches in liquid level sensor head are tripped by adjustable cams (Autocon Industries).

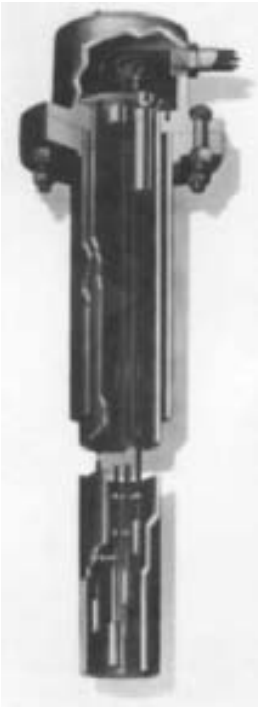
In other applications of the displacer, porcelain bodies on a cable are suspended from the armature of a magnetic head control. In one form, a spring partly supports the weight of the displacers. As liquid rises to the displacers in succession, their apparent weight decreases and the spring can move the cable and armature upward to actuate snap-action switches. The displacers can be moved up and down the cable to initiate action at the desired levels. Three displacers can be mounted on a cable for such applications as one pump actuated by the center displacer, a second pump by either the top or bottom displacer, and an alarm by the third displacer. Displacers are advantageous for dirty or viscous liquids that are still. Levels covered are from 1 to more than 10 ft (0.3 to 3 m).

The pulley shaft of the tape suspended displacer can also drive a potentiometer. The potentiometer output can be applied to solid-state control equipment handling recording, pump start and stop, and alarms.

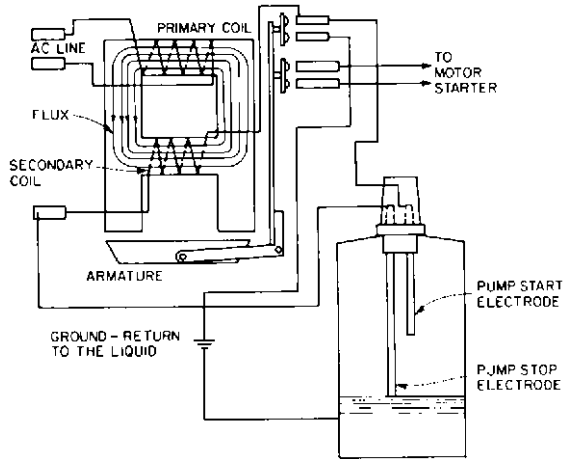
The connection between float and switch need not be mechanical. An armature can be attached to the top of the float rod sliding in a tube. Outside the nonmagnetic tube is mounted the control switch, with a permanent magnet attached to it and set close to the tube. When the level rises, the armature passes the permanent magnet and attracts it, so the switch is actuated. A spring retracts the magnet when the level falls enough, and the switch is reactivated. A float arrangement of this kind, although limited in range, finds use as a low-water cutoff for boilers to 600 lb/in<sup>2</sup> (40 bar\*) gage pressure. Switches are dry-contact or mercury type. Two of these units can be placed at different levels to give both high- and low-limit control.

Liquid level control systems without floats operate on several principles. If the liquid is at all conductive, probes can be used. The electrode probes are fixed, usually mounted in the same holder, and extend down into the tank (Figure 4). Two or three electrodes are

\*1 bar = 10<sup>5</sup> Pa.



**FIGURE 4** Electrodes suspended on cables sense tank water level below ice (B/W Controls).



**FIGURE 5** Induction relay: when liquid reaches pump start electrode, current flows in secondary coil and diverts flux to lift armature and close motor contacts (B/W Controls).

most common. Inductive or electronic relays are also part of the control system and actuate pumps or valves.

In a tank filled by a pump, a drop-in level below the lower electrode breaks the circuit to allow a relay to start a pump or open a valve. When the liquid rises to the high-level electrode, the direct electric circuit between electrodes is established and a relay stops the pump or closes the valve. In an induction relay (Figure 5), the line voltage is separated from the control circuit by a primary and secondary coil arrangement. The relay depends on the specific resistance of the liquid, which can vary from that of metallic circuits to that of demineralized water. Electronic relays have low potential and low electrode current.

Fixed probes usually do not exceed 6 ft (1.8 m) in length, but suspension electrodes are available for deeper tanks or higher level differences. Pressure-tight electrode holders capable of operating at 10,000 lb/in<sup>2</sup> (690 bar) are available. Temperatures are generally limited to 450°F (232°C). For tanks where icing is a problem, a pipe sleeve in which the probes are suspended can be supplied (Figure 4). An immersion heater near the sleeve bottom warms the water when the pump is not in operation.

Bubble sensors measure liquid level by determining the air pressure required to force a small stream of air bubbles through the lower end of a tube extending to the bottom of an open tank. The air flow tends to keep the tube and tube end clear in liquids that contain solids. Floats and probes are eliminated in this method, and only the air flow regulator and pressure switch are exposed to corrosive effects. The air stream flow rate can vary over a range without affecting air pressure. The specific gravity of the liquid must be

known to allow the instrument to be calibrated. Because the measured variable is air pressure, the other instrumentation can be set at distances of 250 ft (76 m) horizontally or vertically. The range of liquid level is 6 in (15.2 cm) to about 32 ft (9.8 m). Sewage, industrial processes, and water supply are some applications.

Notwithstanding the low air pressure involved, the differential sensitivity of pressure switches for bubbler sensors is about 0.5% of maximum operating range. Air consumption is about  $1\frac{1}{2}$  ft<sup>3</sup>/hr (0.042 m<sup>3</sup>/h) when the air flow regulator is set for 60 to 80 bubbles/min. The effects of air pressure failure can be prevented by providing a cylinder of carbon dioxide gas; a pressure switch and solenoid valve will introduce the gas to the system if the compressor fails.

**PRESSURE SENSORS** Pressure controllers of the simple on-off variety may have a single-pole double-throw mercury switch actuated by a bourdon tube. A typical differential value is 2% of maximum scale reading. Adjustment to desired cutin (low) pressure is made by a knob on the case. Pressure ratings go to 5000 lb/in<sup>2</sup> (345 bar) for these devices. Proportional control can be added to controllers of this type by incorporating a slidewire potentiometer (Figure 6).

In other types of pressure sensors, one sensor is provided for pump start and one for pump stop. Adjustable time delay prevents surging or waterhammer from giving a spurious start or stop signal. Increasing liquid pressure transmitted through tubing to an air chamber acts on a bellows and, overcoming adjustable spring tension, trips a mercury switch. The differential sensitivity of the bellows-type sensors is 0.5% of maximum operating range. Maximum pressure is about 175 lb/in<sup>2</sup> (12 bar) gage because the systems are intended for use on open tanks. Sensors, timers, and relays can be mounted in a cabinet located near the tank or even near the pump.

Air trapped in a bell and pressurized by rising water is the actuating mechanism for another alarm switch (Figures 7 and 8). A synthetic rubber diaphragm in the switch body mounted above the bell and connected to it by a small pipe is caused to tilt a mercury switch and thus give the alarm. A rise in level of about  $1\frac{1}{4}$  in (3.2 cm) above the bell mouth will activate the switch.

**ALTERNATORS** An alternator may be installed to achieve regular use and equal wear of each pump in multipump installations. The simplest versions serve on two-pump systems, but more advanced designs can rotate starting sequences of as many as 12 pumps. In one version of the two-pump alternator, a solenoid plunger picks up and causes a four-pole double-throw switch to take alternate positions, maintaining a position after the solenoid is de-energized. If one pump leads with the other coming into service only to augment it, the switching compensates accordingly.

If starting sequence is to be rotated for more than two pumps, a motor-driven rotor can be advanced a given number of degrees each time a pump motor operates. The rotor contacts are connected together in pairs to provide circuits between pairs of stator contacts. Other control variations available in this regard are a change in sequence after a timed interval and an option of starting the pump that has been idle longest and stopping the pump that has run longest. Although many alternators operate on the same voltage as the loads, variants are available for operation from the low voltage and current ratings of control equipment.

**TRANSDUCERS AND TRANSMITTERS** The variable that is most convenient or advantageous to measure is rarely the one best suited for direct use in the control system or for actuation of the final control element. A small differential pressure in a liquid level or flow control system can scarcely open a large valve. Conversion of measured variable values to another signal medium is therefore necessary and is the task of transducers and transmitters. These two terms are used interchangeably to some extent, although the transducer usually converts a signal to an electric current and the output of the transmitter is usually an air pressure.

A pressure-to-voltage transducer is especially useful in pump control. In one design, a bellows subjected to the pressure of the liquid transmits force to a pivoted beam that

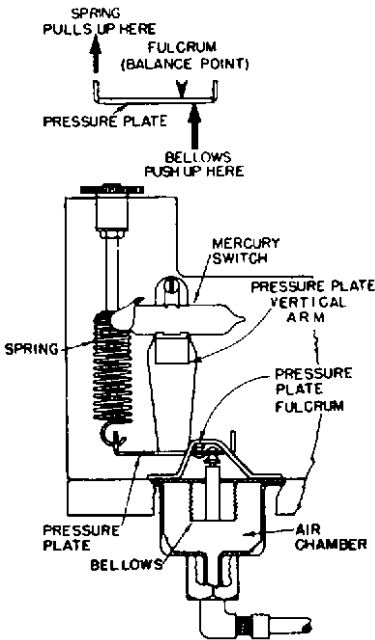


FIGURE 6 Pressure trip point is adjustable in this pressure switch (Autocon Industries).

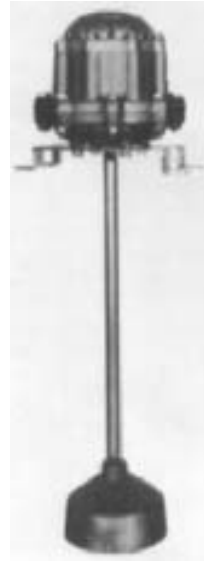


FIGURE 7 Alarm for level rise has bell connected to switch mechanism by 1-ft (0.3-m) pipe (Autocon Industries).

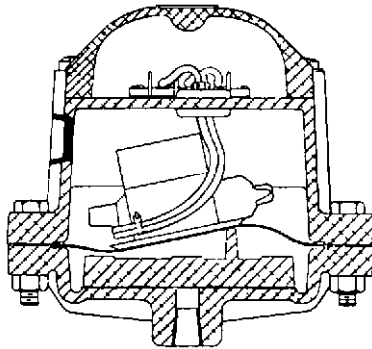


FIGURE 8 Switch assembly for level rise alarm (Autocon Industries)

moves a core in a differential transformer or motion transducer to produce a 3- to 5-V output. The beam is balanced by a spring, and another spring allows the minimum pressure for voltage output to be set, which is equivalent to zero suppression. Zero suppression here can go as high as 95%.

Differential pressure transducers may operate on a force balance principle with a very small motion of the bellows. The motion is converted to rotary motion in a ram or shaft,

which then moves a differential transformer core to give an output signal that can vary from  $-2.5$  to  $+2.5$  V dc.

A transmitter is a device that can sense pressure, temperature, flow, liquid level, or differential pressure and convert the signal to a pneumatic pressure for transmission to receiving instruments several hundred feet distant. The pressure-sensing transmitter can span ranges to  $80,000$  lb/in<sup>2</sup> (5500 bar). The differential pressure type allows low differences in air or liquid pressures, such as a flow orifice develops, to be amplified through linkage and force balance mechanisms. An air pressure of 3 to 15 lb/in<sup>2</sup> (0.2 to 1 bar) in the air line from the transmitter is the result. Differential pressure transmitter designs are available to withstand primary system pressures to 6000 lb/in<sup>2</sup> gage (400 bar), whereas the differential pressures span ranges between 5 to 25 and 200 to 850 in (13 to 64 and 508 to 2160 cm) water.

**TELEMETRY SYSTEMS** When pump control must be exercised over distances greater than the few hundred feet over which most pneumatic control equipment can operate, telemetry systems find application. In some of these systems, the sensor's output is converted to a proportionally variable 3- to 15-V dc voltage at the transmitter input. The transmitter then converts the dc voltage to a square-wave pulse with duration varying in proportion to the input signal. The resultant pulse width modulation (PWM) signal is sent directly over transmission lines or via tone carrier in microwave, VHF, or UHF systems. Transmitting the bipolar PWM signal alone requires direct wiring with less than 500 ohms resistance. This means as much as 24 miles (37 km) on direct telephone lines. The PWM signal eliminates loss of information from signal amplitude variations, and the bipolarity of pulses reduces line capacitance effects.

With tone transmission, either amplitude modulation or frequency shift is used.

The receiver converts the pulse signal back to a variable 3- to 15-V dc signal identical to the transmitter input signal and capable of use for indication or control. If transmission is not received for a certain time period, an alarm can be actuated and the pumps started or stopped.

**Constant Speed Control** Where pump speed control is economically justified, it is a preferred method of obtaining the desired output parameter, such as flow rate, head, or liquid level. If the pump operates at constant speed, there are four common control means:

1. On-off
2. Throttling by valve
3. Bypass by valve
4. Submergence

The on-off method with a single pump largely focuses on liquid level or temperature range control. Centrifugal and positive displacement pumps can be controlled by this method. If an accumulator is installed downstream, the method can be extended to head control. With multiple pumps in parallel, flexibility is slightly greater and a coarse control over flow rate is possible.

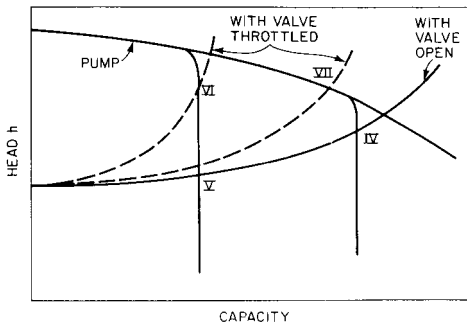
The simplest mechanism for on-off control of constant-speed pumps is the push button switch and starter for across-the-line start of small pumps. For large pumps, reduced-voltage starting is customary. Number of starts per hour is restricted in all cases to prevent overheating. The electric impulse to start or stop the motor can originate in any of the sensors or switches described above.

Throttling by valve is very common and can provide refined control under difficult conditions where rapid response and outstanding dynamic stability are sought, as in boiler feedwater control. Positive displacement pumps cannot use this method.

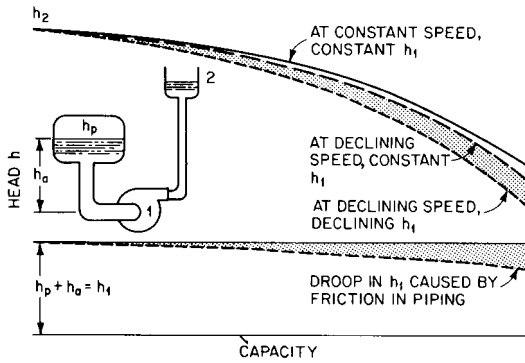
Bypass by valve is an occasional variation of valve control based on the bleedoff of discharge liquid to reduce the flow rate at a downstream point or to allow a cooling flow to pass through a constant-speed pump when its discharge has been blocked. The method can serve both centrifugal and positive displacement pumps.

Submergence control, for centrifugal pumps, relies on a temporary decrease in available *NPSH* to reduce the pump flow rate to the value at which liquid is entering the sump





**FIGURE 9** In submergence control, operation can be at points where restricted-capacity curve intersects piping characteristic (IV, V, VI) or on regular pump characteristic (VII).



**FIGURE 10** The centrifugal pump characteristics changes depending on speed and head at inlet.

(Figure 9). The method services for condensate, and design precautions prevent rapid cavitation damage.

**VALVE-THROTTLING CONTROL** The chief elements of centrifugal pump performance are shown in Figure 10. At any given flow rate (capacity), a centrifugal pump produces a discharge head consisting of the static head on the pump inlet and the dynamic head imparted by the pump. At higher flow rates, speed usually declines slightly, lowering the characteristic curve as shown. In addition, the higher flow rates produce more frictional head loss in the inlet piping so the pump senses an inlet head slightly less than the static head developed by the weight of the liquid column and the effect of compressed gas or upstream pumps.

The pump can deliver any flow rate along the curve. What determines the actual flow rate at any instant is the characteristic curve of the downstream piping (system curve), as shown in Figure 11. Under zero-flow conditions, there is a gravity head of liquid and perhaps a pressure in a container, such as a boiler drum. When liquid flows, piping friction head is added. Piping friction causes the system curve to turn upward, roughly parabolically. If a downstream control valve, previously wide open, is throttled, a new and more rapidly rising system curve is established. The intersection of a pump curve and system curve plotted on a single chart (Figure 12) indicates conditions at the pump discharge. The combined plot also shows that the flow rate or discharge head will be modified by a change in other parameters besides throttle valve setting. For example, an increase in pump speed

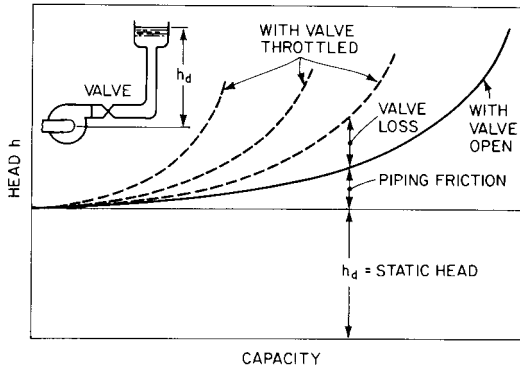


FIGURE 11 Static head, piping friction, and valve loss determine the piping characteristic downstream of pump.

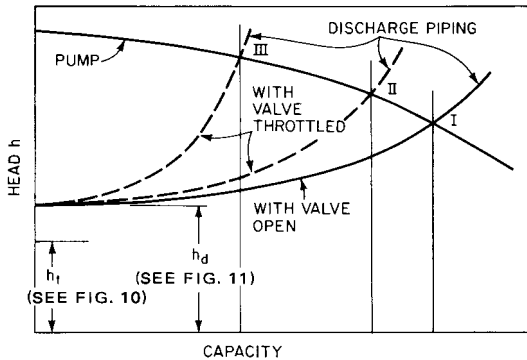
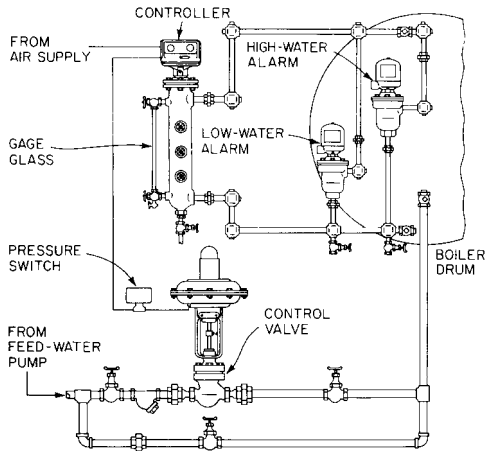


FIGURE 12 Intersection of combined pump and piping characteristics is operating point (I, II, III).

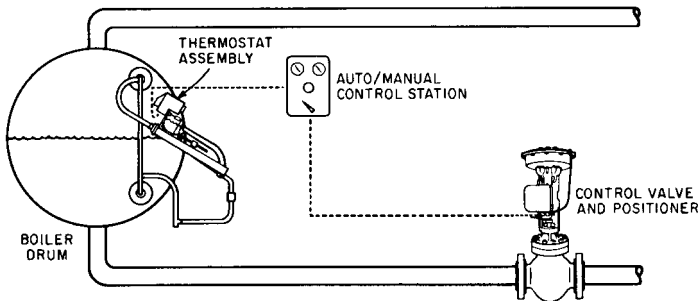
will lift the entire pump curve up and move the intersection point to higher flow rate and head. Decreased pressure in a boiler drum will lower the entire system curve and move the intersection point to higher flow rate and lower head. Throttling the inlet line to the pump will reduce the inlet head and cause the pump curve to start at the same point, but slope downward at a faster rate. The pump curve will then intersect the unchanged (downstream) system curve at lower head and flow rate.

**BOILER FEEDWATER CONTROL** In its original and simplest form, this control maintained the water level in a boiler drum (Figure 13). Although this is still the primary objective in many boilers, in other applications, a balance of steam flow rate against feedwater flow rate is the primary objective, with level maintenance a secondary factor unless it exceeds preset limits. In steam generators operating above the critical pressure of 3206 lb/in<sup>2</sup> (221 bar) abs, the feedwater turns to steam without a water level being visible, so temperature and flow rates are the variables to be controlled.

Both on-off and modulating control are used in feedwater control systems. One classification of boiler feedwater control systems is based on whether the system is electric or pneumatic. Another classification gives the number of variables sensed to determine control valve position: a single-element regulator senses water level alone, a two-element regulator also senses steam flow, and a three-element regulator adds feedwater flow sensing.



**FIGURE 13** Boiler water level control system. In the controller, an external magnet senses position of displacer (Magnetrol).



**FIGURE 14** Single-element boiler feedwater regulator system (Copes-Vulcan)

For low-pressure boilers operating on moderate loads at no higher than 600 lb/in<sup>2</sup> (41 bar) gage and usually far below, on-off control of constant-speed pumps is sometimes used. The control can be similar to a low-water cutoff device actuated by float, but it has two switches: the switch at the higher water level is for level control, and the one below is for low-water cutoff of fuel and for alarm. Level differences of 1 to 3 in (2.5 to 7.6 cm) start the pump. This type of control can have a third switch, installed to give a separate alarm for low water before the fuel cutoff. With fire-tube boilers, the third switch can give a separate high-water alarm if the pump does not stop when the pump cutoff switch is actuated.

Regulators directly actuated by float are also in use. Valves for these regulators are usually two-seated to reduce the thrust required of the float and linkage mechanism. Boiler pressures are low for this method, below 250 lb/in<sup>2</sup> (17 bar), although the regulators can be built to withstand 600 lb/in<sup>2</sup> gage (41 bar). Capacities go to more than 400,000 lb/h (180,000 kg/h) at pressure drops of 100 lb/in<sup>2</sup> (7 bar) across the valve.

For more demanding service, modulating control by means of an amplified signal applied to a valve actuator is necessary. The simplest type of modulating control of this kind is a single-element regulator, serving for fairly constant loads and pressures (Figures 13 and 14). In the pneumatic system, a change of water level in the boiler drum provides a pneumatic output signal that is transmitted to a controller supplying air pressure to the

diaphragm or piston actuator of a control valve in the discharge line from the feedwater pump. A sensing thermostat for drum water level may be designed as a proportional controller, with gain changing in proportion to deviation from the set point. Linkage transfers the elongation of the sensing element to the pneumatic transmitter. Torque tubes or magnetic couplings (Figure 13) may also convert the water level sensing of a float or displacer to a pneumatic signal, in any of the standard pressure ranges. The air pressure required for the feedwater control valves must usually be at least 50 lb/in<sup>2</sup> gage (3.4 bar), and up to 125 lb/in<sup>2</sup> (8.6 bar) gage may be necessary. Balanced-trim valves do not require as high air pressures as do the unbalanced-plug type, and the small amount of leakage is not harmful.

In some single-element systems, the sensing element directly actuates the valve. In one system of this type, a high enough vapor pressure is produced in an enclosed tube to operate the feedwater control valve directly. The vapor pressure generator consists of a slanting inner tube mounted beside the boiler drum, with ends connected on top and bottom of the drum. A finned outer tube, filled with a liquid and connected only to the control valve actuator, envelops the inner tube. A decrease in water level brings more heating steam into the inner tube to warm the liquid in the outer tube and increase its vapor pressure. The vapor pressure is transmitted to the valve actuator to open to the valve.

In an electric control system, the level sensor can emit a signal modified by a slidewire potentiometer. The valve operator is an electric motor. In the larger sizes, the valve actuating speed will be low, so the system cannot respond quickly to rapid change in steaming rate and water level.

Some single-element systems employ a pressure control valve directly upstream of the main feedwater control valve. The upstream valve, called a differential valve, maintains a constant pressure on the feedwater control valve, improving its performance. Pressure control valves of this type have been used on some more advanced systems, too.

Single-element systems are inadequate for a boiler whose steaming rate changes suddenly because of the anomalous behavior of the water level during the change. A sudden demand for steam will reduce pressure in the drum, and steam bubble formation will increase, temporarily raising the water level at precisely the time when a falling level is required to signal for increased feedwater flow. The anomaly is called a rising water level characteristic. If the steaming rate change is gradual, the characteristic can be constant or even lowering.

The two-element regulator (Figure 15) solves this problem by sensing steam flow through an orifice in the steam main. The flow rate signal goes to the controller, and a sudden increase in steam flow will temporarily override the spurious water level signal.

Three-element control (Figure 16) offers a further refinement—it senses feedwater flow rate in addition to water level and steam flow rate. During a rapid and large load swing, the feedwater flow rate can then be adjusted to the steam flow rate, while the water level is simultaneously noted. The feedwater flow rate signal is converted to a linear signal for transmission to a computing relay that can be adjusted for the relative influences

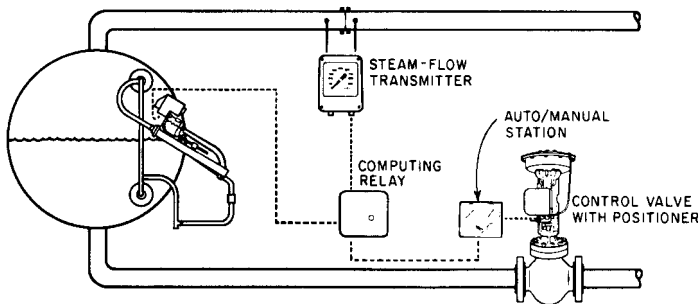
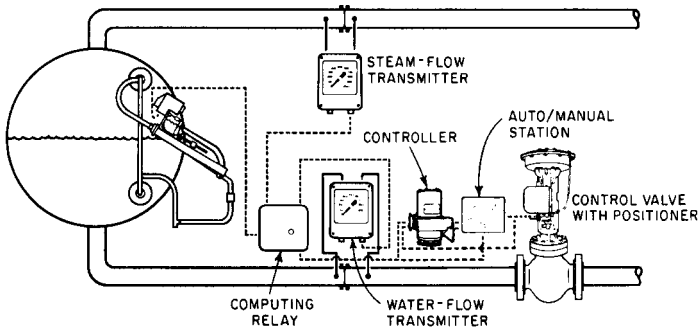


FIGURE 15 Two-element regulator system with steam flow measurement (Copes-Vulcan)



**FIGURE 16** Three-element regulator system action depends on water level, steam flow, and feedwater flow (Copes-Vulcan).

of the three variables. A balanced signal then goes to the drum level controller, whose air output actuates the control valve. Three-element control systems can eliminate the effects of pressure variations upstream of the regulating valve.

**BUILDING-WATER PRESSURE CONTROL** In tall buildings or large industrial, commercial, or housing water systems, water pressure can be maintained in several ways. If elevated or pressure tanks are not desired, a multiple-pump system may be considered. The pumps can be constant-speed or variable-speed. For constant-speed pumps, pressure sensors bring in individual pumps as required to maintain pressure. If a large number of pumps are necessary, means must be provided to prevent all of them from starting simultaneously on restoration of power after a failure. (See Section 9.21.)

Hydropneumatic systems rely on air pressure in the top of a tank into which pumps deliver water intermittently. As water is drawn off, the air expands, reducing its pressure and eventually requiring another pump start. Both pressure and water level are sensed. If the pump liquid does not bring in enough air to the tank to make up for losses, an air compressor or the compressed-air system must supply air. Tank pressure after each level-controlled pumping cycle indicates whether more air is needed or whether air should be bled off. Float or probe sensors can determine liquid level, and various pressure sensors are available.

## VALVES

For the final control element, conventional and traditional valves serve for on-off control in pump systems. They also cover much of the modulation need. In recent years, modulating control in demanding services has required development of special control valves, actuators, and accessories. System dynamic characteristics, corrosion, erosion, noise, and costs have influenced the development.

**Operation and Valve Types** The on-off operation of pump valves serves for

1. Isolation of a pump: protection, maintenance, removal, administrative reasons
2. Bypass or partial isolation: inlet or outlet block for protection, improved flow control, administrative reasons
3. Pressure relief: protection
4. Venting: removal of gases and vapors from the casing
5. Draining: removal of liquids from the casing

The modulating mode of operation services for

1. Control of flow rate to pump or of pressure at inlet
2. Control of delivered flow rate or pressure
3. Control of bypass flow rate

Auxiliary flows in lines to packing boxes, seals, and sensing or measuring elements are controlled by either on-off or modulating valves.

The principal types of valves for on-off and much modulating service are

- Gate (rare for modulating)
- Globe (and angle)
- Butterfly
- Ball
- Eccentric butterfly
- Plug
- Diaphragm

Check valves and relief valves, although possessing design features peculiar to their nature, make use of the essential features of globe and butterfly valves.

Control valves have developed as a special group for demanding services that require wide modulation range, stability, wear resistance, low noise, or a specific flow characteristic. Ingenuity and experience have combined to evolve many unusual but effective designs, each with advantages and drawbacks.

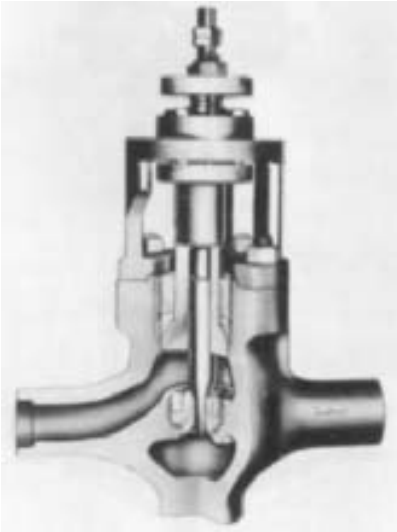
**Control Valves** A control valve is a valve that modulates the flow through it to provide the desired downstream (or upstream) pressure, flow rate, or temperature. Although most types of valves can be partly closed and thus give a degree of control that may be acceptable for many purposes, the term *control valve* has come to mean a specialized type of power-actuated valve designed for good performance under steady-state or dynamic flow conditions.

Before examining various control valves and their reasons for existence, some basic practical concepts must be reviewed. A control valve includes

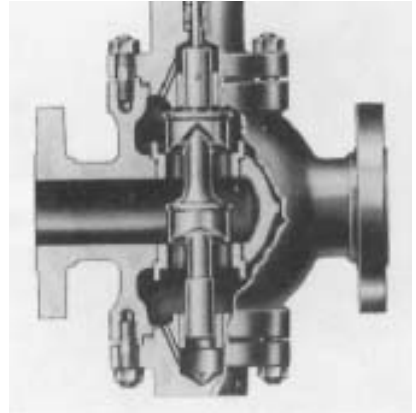
1. A body to contain the pressure, direct the liquid flow, and resist loads from piping and actuation
2. A variable orifice or orifices
3. A stem for positive connection of orifice elements to actuator
4. A piercement through the body wall to allow the stem to pass
5. An actuator to adjust the orifice size

Adaptations of globe valves and angle valves are common. These forms inherently give tight shutoff. High-quality trim helps resist erosion and wear at low flow rates when the orifice is nearly closed. Support is often provided for the stem to prevent vibration and flutter (Figure 17). The plug can be characterized (shaped to give certain rates of flow for given percentages of opening) as desired. The support of the stem is usually on the bonnet side of the orifice rather than opposite, to keep orifice size down. With flow upward (through the orifice, and then past the plug), the actuator must overcome upstream pressure to close the valve. With flow downward (past the plug, and then through the orifice), valve motion becomes unstable when the valve is nearly closed.

The basic globe valve is often modified to put two orifices and plugs on the same stem, with the upstream fluid entering the space between and passing in two opposite flows



**FIGURE 17** This control valve is basically a globe type, with reduced trim and guided tapered plug (Copes-Vulcan).



**FIGURE 18** Double-seated control valve with characterized plugs (Masoneilan International)

through the two orifices. This is the double-seated valve (Figure 18). Actuator force is greatly reduced because fluid pressure tends to open one plug and close the other. The balance is not complete, however, because one orifice is usually larger than the other to permit assembly and because there is a difference in head conversion effects in the orifices at low flow rates.

Addition of an internal diaphragm and a port in the body near one orifice makes the valve a three-way type, able to divide flow between two outlet lines or, with reversed flow direction, combine two flows in a desired ratio. The double-seated valve cannot seal tightly because of manufacturing tolerances and thermal and pressure effects on the valve body.

Butterfly valves can modulate flow (Figure 19). Special vane shapes have been introduced to improve performance. Elastomer or plastomer linings give a tight shutoff on liquids within the temperature range of the materials.

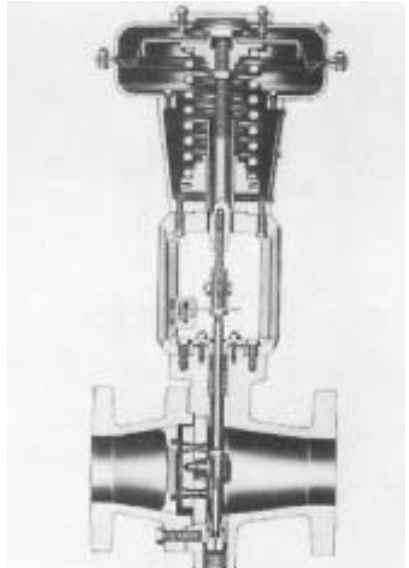
Ball valves as control valves may take conventional form, with an actuator and positioner atop the valve. In other designs, the ball may be merely a fraction of a spherical shell, adequate for sealing on the customary tetrafluoroethylene seat ring but with its edge shaped to develop the required characterized flow as the shell rotates and exposes the orifice. Convex, V-notch, and parabolic edge shapes find use. The conventional ball valve has two variable orifices in series, of course, with a small chamber between them in which some head recovery occurs as fluid momentarily slows.

A specialized form of gate valve can serve as a control valve. This type contains a multiple-orifice plate mounted permanently as a diaphragm perpendicular to the line of flow (Figure 20). The "disk," a plate that also contains two or more slotted orifices, is mounted to slide vertically across the upstream side of the stationary plate. The degree of orifice coincidence determines the flow rate. Actuation is by a pin mounted on the stem and protruding through the stationary plate into a pocket on the sliding plate. Low vibration and straight-through flow are characteristic of this valve. The actuating force is low at all flow rates because of the sliding action of the lapped disk and plate and because of the disk support. Both disk and plate are made of stainless steel or other alloys.

**CAGE VALVES** This type has developed into an entire group of control valves (Figures 21 to 25). The valve body closely resembles that of the globe valve, with a large orifice in a



**FIGURE 19** Butterfly control valve with linkage connecting spindle to diaphragm actuator and positioner (Masonilan International)



**FIGURE 20** Movement of one plate past another opens or closes flow orifices in this control valve (Jordan Valve Division, Richards Industries).

horizontal area of the central diaphragm. The cage is a hollow cylinder that is held between the bonnet and the edge of a hole in the diaphragm. The disk or plug, sliding up and down inside the cage, is guided by it.

In most cage valves, the lower zone of the annular cage is available for flow control orifices, alternately exposed and covered as the plug moves up and down (Figure 21). Tight shutoff at these orifices is impossible, of course, and so the bottom of the cage or a separate seat ring is machined and finished to match a seating surface on the plug.

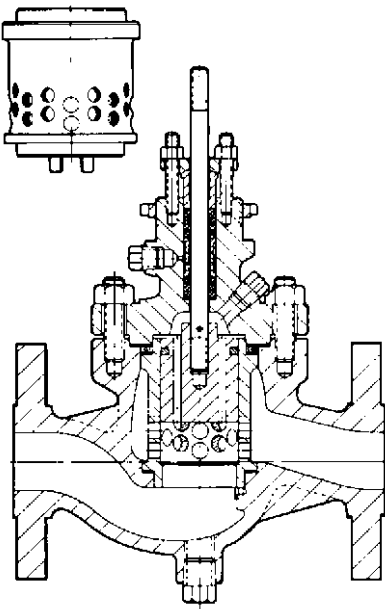
In other cage valves, where the plug may be much smaller than the cage inside diameter (Figure 22), all control action is at the lower seat ring. The plug guiding is then on the stem or in the seat ring orifice, and the holes in the cage are merely passage holes to distribute the liquid evenly around the perimeter.

The seat ring in cage valves is retained by bonnet bolting forces acting through the cage. Gaskets take up tolerances in dimensions and finish, so the seat ring need not be pressed or screwed into the valve diaphragm.

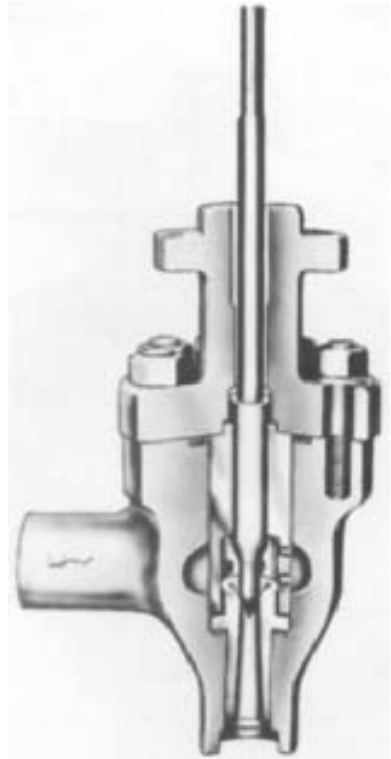
The ordinary cage valve has several advantages. Suitable machining of cage holes can give the valve the desired characteristics. Removal and replacement of internals, such as cage and seat ring, are quick and simple. A vertical hole through the plug makes the valve nearly balanced (Figure 23), although considerable leakage can occur between plug and cage wall if the plug is balanced in this way. Cage wall orifices vary not only in number, size, and cross-sectional form, but also in path and surface roughness.

In one advanced variation of the cage valve, the cage wall is comparatively thick and the many pathways through it are labyrinthine, with several right-angle turns and several orifices and expansion chambers in each pathway (Figure 26). To make the cage practical from a manufacturing standpoint, it consists of a series of thin disks each carrying a pattern of labyrinthine paths in one surface. The opposite surface is flat, so when the disks are stacked into a cage, the paths are sealed from one another. Flow in valves of this type can be from inside or outside the cage. Characterization is possible by such means as a change in the number of orifices per disk at various heights in the stack. As in conventional cage





**FIGURE 21** Hole pattern in cage can reduce noise and cavitation (ITT Hammel Dahl Conoflow).



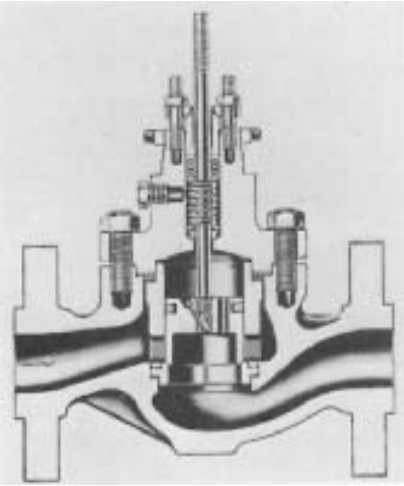
**FIGURE 22** Tapered outlet section improves flow pattern in this cage valve (Copes-Vulcan).

valves, the trim and characterization can be quickly changed after bonnet removal. The bonnet bolting, outside the liquid, holds the cage elements in place.

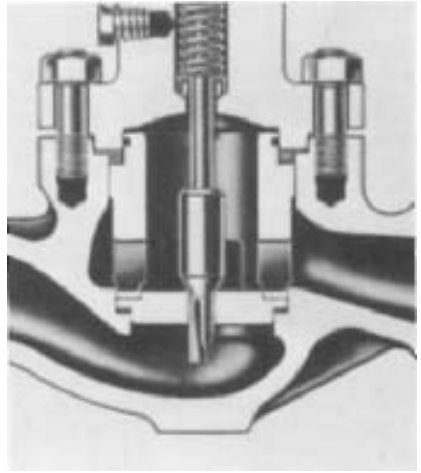
In other cage valves, the passage walls may be wavy, resembling screw threads. This assists in noise reduction in gas valves.

**MULTIPLE ORIFICES IN SERIES** Several valves have orifices in series rather than in parallel; the principle is called *cascading*. In one group, a tapered plug with a series of circumferential serrations moves in a tapered seat that may be either conical or stepped (Figures 27 and 28). In either case, the serrations or steps produce a series of small annular chambers alternating with annular restrictions that serve as orifices. Some alternating change in flow direction also occurs to create the desired head loss.

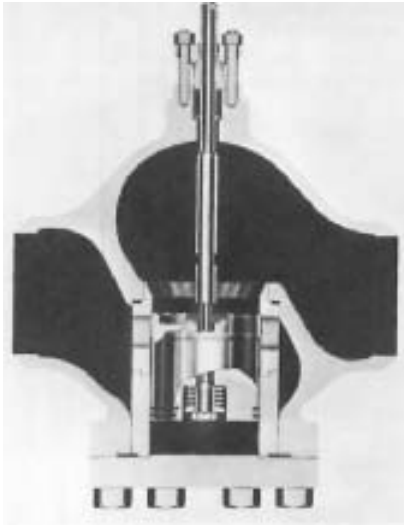
In another group, annular chambers in the wall of a cylindrical cage are separated from one another by ridges that are a close fit with annular ridges on a sliding plug. The orifices narrow as the ridge sets approach one another, whereas the expansion chambers remain nearly constant in size. Repeated change in flow direction and speed produces head loss. In a variation of this type (Figure 29), the chambers on the cylindrical plug are short, steeply angled helical cuts, so the liquid takes a helical path. The purpose is to fling the liquid against the walls of the cage and displace cavitation bubbles toward the center and away from wall contact. Shutoff in these valves cannot rely on the multiple-orifice systems, but instead depends on a separate conventional seat and plug surface, either upstream or downstream of the orifice system.



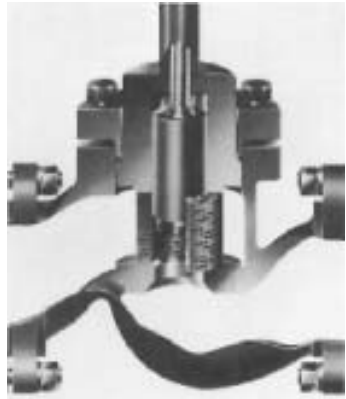
**FIGURE 23** Holes in plug allow pressure balance in this cage valve (Fisher Controls).



**FIGURE 24** An extreme in reduced trim for a cage valve (Fisher Controls)

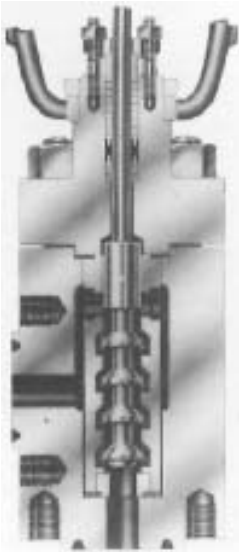


**FIGURE 25** Cage valve with bottom access (Copes-Vulcan)

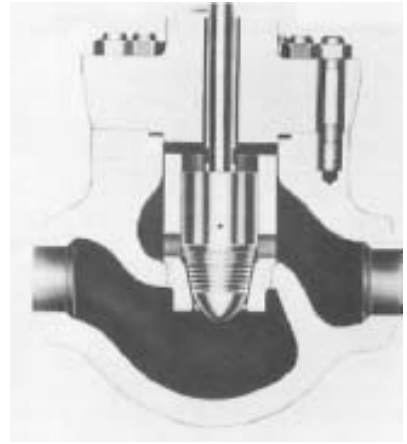


**FIGURE 26** Control valve with flow through labyrinthine orifices in built-up cage (Control Components)

Many of these special valves are very expensive because of the multiplicity of complicated parts and because of the reduction in capacity caused by the advanced design. Larger bodies and overall sizes are required for a given flow rate. In pump control, the valves see service on high-pressure feedwater pump minimum-flow recirculating lines, where pressures go as high as 6000 lb/in<sup>2</sup> (400 bar) and water temperatures range to 500°F (260°C). Tight shutoff over thousands of operating cycles is the goal.



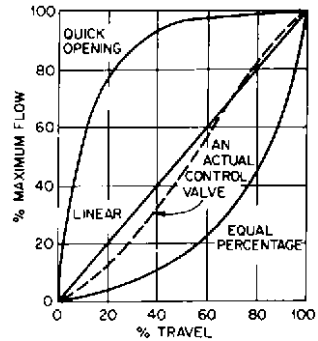
**FIGURE 27** Pressure breakdown occurs across several annular orifices and direction changes in this valve (Masonelan International).



**FIGURE 28** Serrations on large plug give high pressure drop at low flow (Copes-Vulcan).



**FIGURE 29** Pump bypass flow at high pressure drop results when line flow at top ceases and mechanism opens valve at right (Yarway).



**FIGURE 30** Basic control valve characteristics. Valves are designed to approach these.

**FLOW CHARACTERISTICS** An important parameter for valves in modulating control is the flow characteristic of the valve, often called simply the characteristic. The flow characteristic expresses the way in which the flow through the valve depends on percentage of valve stem travel. The latter may be translatory or rotary motion, of course. A plot of percentage of maximum flow at various percentages of stem travel is the usual quantitative way of showing a characteristic (Figure 30). Several types of characteristics have become

common, either because of inherent desirability or because familiar and traditional types of valves have them.

The linear characteristic is a straight line, with flow percentage always equal to stem travel percentage. A quick-opening characteristic, on the other hand, produces proportionately more flow in the early stages of stem travel. An equal-percentage characteristic gives a change that, for a given percentage of lift, is a constant percentage of the flow before the change. A change of 16% of total stem travel will double the flow, so at a stem travel of about 84%, flow will be 50% of maximum.

Although the linear characteristic would seem best because the rate of flow change is uniform for a given stem travel change, incorporation of the valve into a piping system affects the decision. Because resistance to flow in a given piping system is roughly proportional to the square of the flow rate, the curve of the piping system head loss plotted against flow rate will be a parabola, with resistance increasing at a faster rate than flow. If the piping system and valve are considered together and the flow rate in the system plotted against percentage of valve stem travel, the overall system characteristic will differ from the valve characteristic. The overall system characteristic is displaced upward toward the quick-opening valve characteristic but can have points of flexure. The amount of displacement depends on what part of the total system pressure drop is taken by the valve. Only with a very short outlet pipe would the valve take all the pressure drop, and then its characteristic would be that of the system.

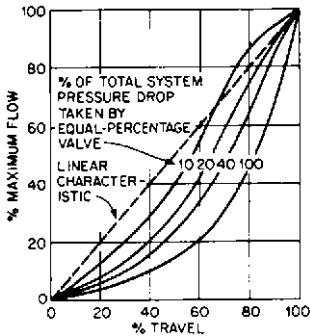
In many systems, the pressure drop across the valve is designed to be from one-tenth to one-third of the total system drop. If the valve in such a system has an equal-percentage characteristic, the characteristic of the overall system will be close to linear as far as the actuator of the valve is concerned (Figure 31).

The equal-percentage characteristic is obtained by such measures as contouring the valve plug, contouring slots in plug skirt or cage, or suitably spacing holes in the cage.

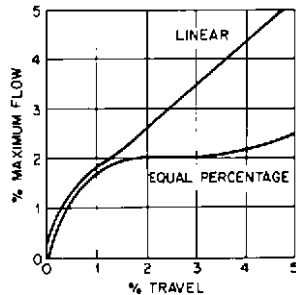
Valves with a characteristic between linear and equal-percentage are also useful in modulating control. Ball, plug, and butterfly valves are examples. Characterized ball and plug valves are examples of modifications for control characteristic purposes.

**RANGEABILITY** Control valve rangeability (Figure 32) can be important in some cases; it is defined as the ratio of maximum flow to minimum flow at which the valve characteristic is still evident and control is possible. A high rangeability value means that a single valve can handle low as well as high flows, so auxiliary valves are unnecessary. The best performance in this regard is about 100:1 for special designs under favorable circumstances, and 25:1 is common for conventional valves and ordinary circumstances.

Connected with rangeability is *valve gain*, which is the slope of the flow characteristic curve at any point. In practical terms, valve gain is the change in flow rate per unit of



**FIGURE 31** For a valve in a system, the overall characteristic depends on valve characteristic and pressure breakdown.



**FIGURE 32** Rangeability of a valve is determined by the point at which valve characteristic is still evident, between 1 and 2% of maximum flow for the two valve characteristics shown here.

change in stem travel. A high gain means that a slight movement of the stem causes a large change in flow rate, so instability occurs more readily. This sets a limit on a valve's rangeability. The quick-opening valve, with a high gain in the nearly closed position, is unsuitable for many modulating tasks.

Valves with approximately an equal-percentage flow characteristic are considered most suitable for the majority of flow control tasks; valves with a linear characteristic are preferred for some applications.

**SIZE** The *size* of a valve is an indefinite concept. In the past, a valve's size was understood to be the pipe size of the line connected to it. Venturi valves with tapered end passages leading to reduced-diameter orifices and valves in which the orifice area is reduced for reasons such as cost-cutting, characterization, and special advantages have forced users to rate valve size in other terms. A statement of maximum orifice area might be a way to express size, but this too would be ambiguous because the head losses in partial recovery after the orifice are not the only losses in the valve. In addition, the valve may have two or more orifices in series, and the geometry of the orifice itself may affect results.

**FLOW COEFFICIENT** The valve flow coefficient  $C_v$  ( $K_v$  in SI units) is now a frequently used parameter for valve size. It is the number of gallons per minute (cubic meters per hour) of 60°F (15.6°C) water that will flow through a valve at a 1-lb/in<sup>2</sup> (1-bar) pressure drop across the valve. The upstream test pressure is also stated. The maximum  $C_v$  ( $K_v$ ), found with the valve fully open, is widely accepted as a measure of valve size. To find the maximum liquid flow rate of a valve at any pressure drop and with a liquid of any specific gravity, the equation is

in USCS units 
$$Q = \frac{C_v}{(G_t/\Delta P)^{1/2}}$$

in SI units 
$$Q = \frac{K_v}{(G_t/\Delta P)^{1/2}}$$

where  $Q$  = flow rate, gpm (m<sup>3</sup>/h)

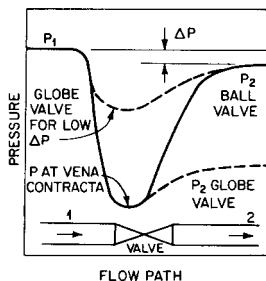
$C_v$  = valve flow coefficient in USCS units

$K_v$  = valve coefficient in SI units

$G_t$  = specific gravity of the liquid

$\Delta P$  = pressure drop across valve, lb/in<sup>2</sup> (bar)

**PRESSURE RECOVERY AND CAVITATION** A drop in liquid pressure upon passing through a valve is recovered to varying extent downstream (Figure 33). The degree of recovery



**FIGURE 33** For a given pressure drop  $\Delta P$  across a valve, the globe will show a higher pressure at the vena contracta, making it more likely that cavitation difficulties will be avoided when the vapor pressure is high.

depends on valve type: ball and butterfly valves have higher recovery percentages than do globe and angle valves. To avoid cavitation, which is the formation of vapor bubbles near the *vena contracta* of the valve, followed by a sudden damaging collapse near the metal, the static pressure at the *vena contracta* must be above the liquid vapor pressure. This is easier to do with a low-recovery valve because the initial pressure drop need not be as high for a given downstream pressure. Several factors have been devised to indicate pressure recovery. One,  $C_p$ , the critical flow factor, is the ratio of pressure recovery, varying for different valve openings. Another,  $K_m$ , the valve recovery coefficient, is the ratio of pressure drop across the valve to pressure drop between valve inlet and *vena contracta* at that instant when flow begins to be choked by bubble formation. Both of these factors will be higher for globe valves than for ball and butterfly valves, and the factors serve to indicate valve suitability for marginal cavitation service.

**ACTUATORS** The motion needed to change the valve orifice area and to close the valve tightly is produced by an actuator. The types of motion of the valve plug or disk are either linear or rotary (Figure 34), the latter being usually  $90^\circ$  but occasionally as low as  $70^\circ$ . These motions can be effected in several ways. The linear translating motion can result from a cylinder or diaphragm actuator working directly or through linkage (Figure 35). A screw thread at the stem top can convert a rotary motion to linear stem motion, or threads at the stem bottom can engage threads in the valve disk so rotation of the stem moves the disk. Geared electric motor drives (Figure 36), cylinders (Figure 37), and diaphragm-and-spring actuators (Figure 38) are common with ball, plug, and butterfly valves. The solenoid valve (Figure 39) relies on an electromagnetic force to move a disk directly or to initiate the piloting action that allows line fluid to open the valve. The piloted solenoid valve (Figure 40) relies on fluid pressures to open the main orifice.

The simplest actuator is the manually powered operator, which is a gear box. It provides enough mechanical advantage to overcome starting friction and to seal the valve tightly. Provision for an impact blow to initiate opening is found in some operators.

The choice of actuator depends first on whether the service is on-off or modulating. For on-off service, the actuator need have only enough force to overcome breakaway force or torque and sufficient stroke to open the valve fully. Speed of operation is rarely critical, and motion limits can be designed into valve or actuator. Pneumatically (Figure 41) and hydraulically powered actuators usually stroke rapidly but can be slowed in either direction by auxiliary valving or controls. On some pneumatic actuators, times to five minutes are possible. Electric-motor-driven actuators are slower than pneumatic or hydraulic types and require limit switches to stop the motor at the end of travel.

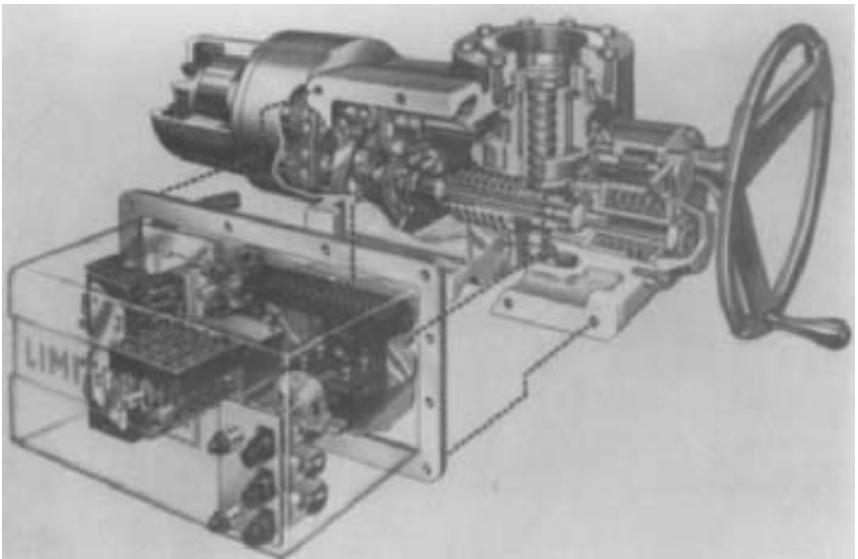
In modulating service, where the actuator must hold a control valve setting, demands are more severe. The speed of movement, expressed as stroking speed, is sometimes an important factor, especially in emergency shutdown or bypass. The stability of an actuator is partly its ability to hold the valve setting under fluctuating or buffeting



FIGURE 34 Rotary actuator with sealed blade (Vomox)



**FIGURE 35** Linkage connects actuator and valve stem (Masoneilan International)



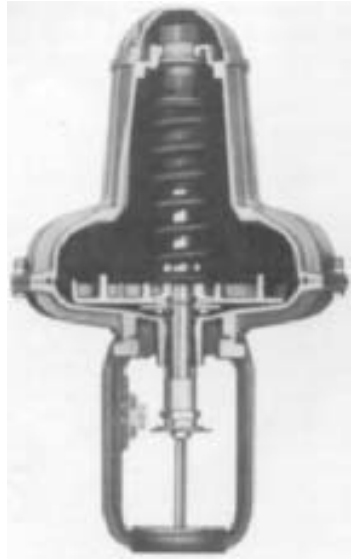
**FIGURE 36** Electric-motor-driven actuator with mechanism for limiting torque (Philadelphia Gear)

loads from the fluid. Damping and high spring rate can help with this. The relation of the natural frequency of the actuator and its adjacent elements to the frequencies encountered in controlling the flow or those experienced from fluid buffeting can also be important.

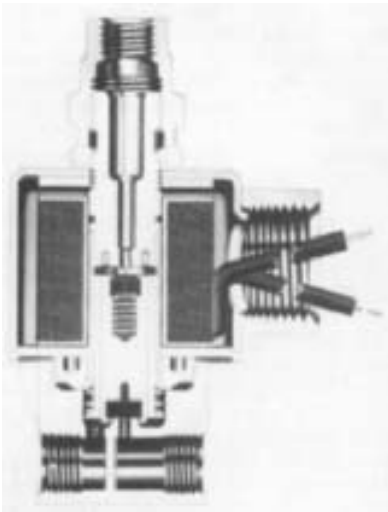
Stroke length is also a factor. Although the disk in a globe valve or similar type need lift only one-quarter of the seat diameter to give adequate area for full flow, this distance in large valves will exceed the 2-in (5-cm) stroke of most diaphragm actuators. If linkage



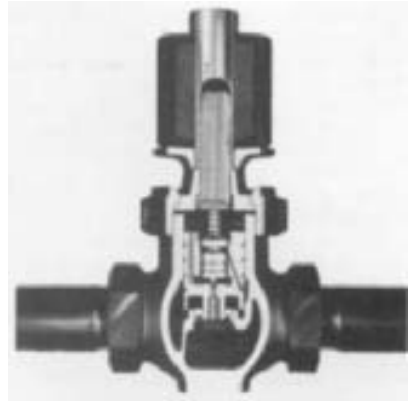
**FIGURE 37** Cylinder actuator and linkage for ball valve (Jamesbury)



**FIGURE 38** Diaphragm-and-spring actuator, reversible type (Foxboro)



**FIGURE 39** Solenoid valve for three-way operation is direct-acting (Skinner Precision Industries).

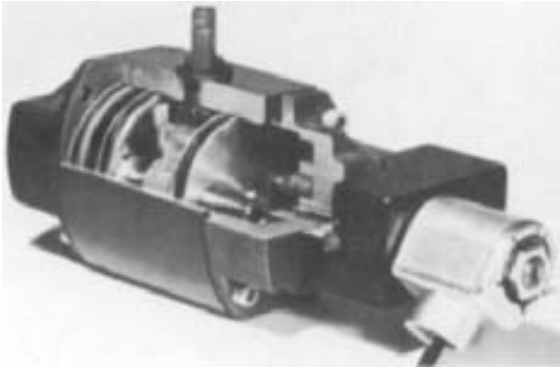


**FIGURE 40** Piloted solenoid valve relies on fluid pressure to open main orifice (Magnetrol Valve).

with its lever advantage is needed to increase thrust, the problem becomes more acute. A cylinder or electric actuator is then necessary.

The source of power for the actuator influences choices too. One standard may be 3- to 25-lb/in<sup>2</sup> (0.2- to 1.7-bar) instrument air pressure, whereas in other cases much higher air or oil pressure is available.





**FIGURE 41** Opposed pistons drive rack-and-gear mechanism for 90° rotation in this pneumatic actuator (Worcester Controls).

The diaphragm-and-spring actuator (Figure 38) is a very common type and has several important advantages. The spring can be pre-loaded to cause the valve to either close or open fully (be fail-safe) if control air fails. The spring also opposes the force generated by the control signal, doing so in a manner giving proportional control. Of course, the spring's opposition negates much of the force available on the diaphragm, but the simplicity and low friction of this actuator have made it very popular. Most modern types are reversing: The fail-safe action can easily be changed from open to close by turning the diaphragm enclosure upside down and reassembling.

**POSITIONERS** With actuators that lack an internal spring, a positioner is needed to adjust the valve position to the desired value. A positioner is a small feedback system that receives an input signal (usually air pressure but sometimes an electric signal) from a controller and adjusts a valve stem position to a prearranged corresponding value. The valve stem position, which is the output, need not vary linearly with input pressure; cams in the mechanism can give a wide range of stem position functions and thus apparently change the characteristic of the valve.

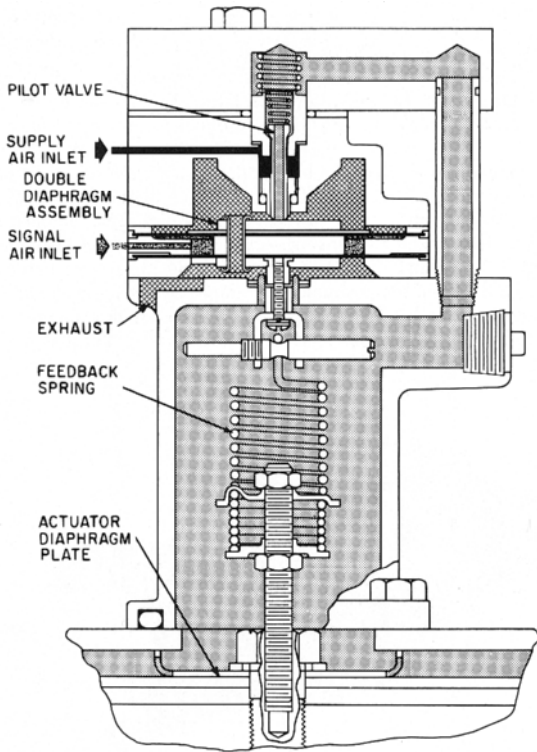
The positioner is a necessity for actuators in which the valve stem position is not a function of the actuator fluid pressure or electric current magnitude. Examples are pneumatic and hydraulic cylinders and electric motors. Even though positioners are not inherently necessary on the diaphragm-and-spring actuator, they are sometimes applied. The reasons for the application hold for other types of actuators, too.

Friction in the actuator diaphragm cylinder or valve stem packing is one reason. The positioner can cut the dead-band from values such as 5 to 15% to less than 0.5% and can give repeatability of 0.1% of full span.

Need for more force to close a single-seat valve tightly is another reason for using a positioner. If loading pressure must be increased above a standard 15 lb/in<sup>2</sup> gage (1-bar) value, the positioner can control air at a higher pressure and thus greatly increase the stem force.

Split-range operation, in which different valves operate over different parts of the controller output pressure range, calls for positioners. Reversal of valve action, too, is easily achieved with positioners. A positioner can also speed up valve response because the low-volume positioner will act faster than the high-volume valve actuator and can open a larger air supply than that in the controller. A pneumatic amplifier or booster is an alternative way to do this. Finally, change in control valve characteristic, such as from linear to equal-percentage, is also possible through a positioner cam.

Because a positioner is another control loop added to a system, its effect under dynamic conditions may worsen overall performance. If changes or oscillations are slow, the positioner and actuator will follow them accurately and correct for them. For rapid changes, however, the effect of the positioner can be harmful. Evidence shows that if the natural fre-



**FIGURE 42** Force-balance positioner with spool and sleeve pilot valve (Masoneilan International)

quency of the complete process control loop is more than 20% of the frequency at which the gain in the positioner-actuator system is attenuated 3 dB, the positioner will impair system performance. Liquid level control systems are more likely to benefit from positioners than are flow or pressure control systems.

Pneumatic positioners may be classified as force-balance or motion-balance types. In the force-balance type, the force in the range spring inside the positioner is balanced against control air pressure inside a bellows or double-diaphragm assembly. In the force-balance positioner of Figure 42, the feedback spring, which can be adjusted for range of pressure and initial actuation pressure, is attached to the actuator diaphragm plate at the bottom and to a double-diaphragm assembly at the top. The upper diaphragm has twice the area of the lower; introduction of signal air from the controller into the space between the two diaphragms forces the assembly upward very slightly but enough to lift a pilot valve at the positioner top and allow supply air pressure to flow through and downward past the feedback spring to press the actuator diaphragm down until forces balance. A reduction in signal pressure allows the double-diaphragm assembly to move downward, first closing the pilot valve and then exposing a hole through the pilot valve stem. Air then bleeds out from the actuator to atmosphere until forces are again in balance.

In the force-balance positioner of Figure 43, flexure strips and a bell crank convert the vertical actuator motion to a horizontal motion in the double-diaphragm assembly at the top left and the supply valve at the right.

A motion-balance positioner showing the application of a cam to impart a characteristic is shown in Figure 44. The cam at the lower right is pivoted and caused to rotate by the

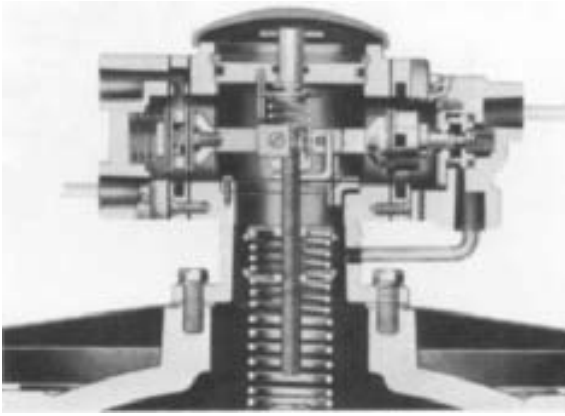


FIGURE 43 Force-balance positioner with flexure linkage (ITT Hammell Dahl Conoflow)

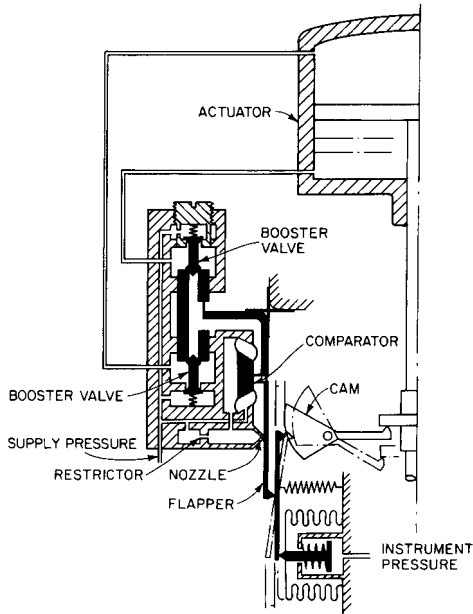


FIGURE 44 Motion-balance positioner with cam and diaphragm comparator (ITT Hammell Dahl Conoflow)

actuator stem motion. Supply pressure enters the valve assembly block at the left and goes to both booster valves. It also bleeds through a restrictor and nozzle at the bottom of the valve assembly block. The position of the flapper before the nozzle determines the pressure in the diaphragm comparator at the right of the valve assembly block. An increase in signal air pressure to the bottom bellows moves one end of a balance beam and pushes the flapper closer to the nozzle. This builds pressure in the diaphragm comparator and moves it to the right. A linkage transforms this motion into a motion that opens the booster valve

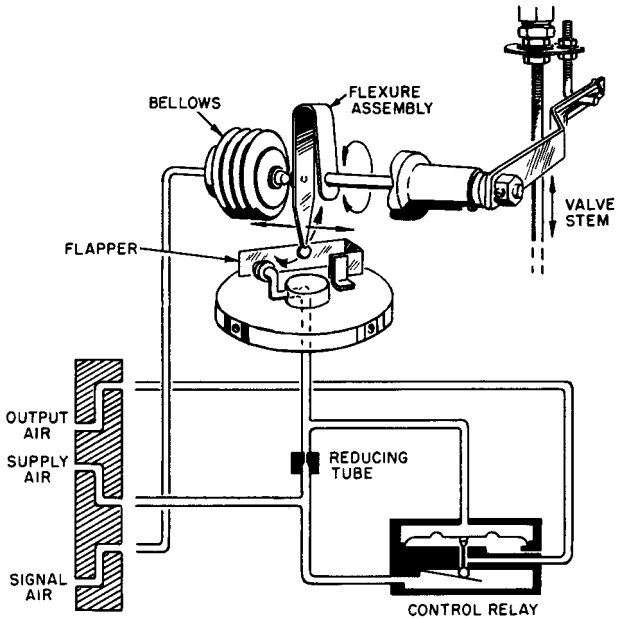


FIGURE 45 Motion-balance positioner with flexure assembly (Foxboro)

to supply air to the cylinder actuator top and permits air to exhaust from the cylinder bottom. The actuator stem moves down until the feedback cam, aided by the comparator linkage, has repositioned the flapper in front of the nozzle.

In another motion-balance positioner (Figure 45), signal air pressure from 3 to 15 lb/in<sup>2</sup> (0.2 to 1 bar) gage in a bellows opposes a flexure assembly on a shaft that is rotated by the valve stem motion. An increase in signal air pressure to the bellows expands it and moves the lower end of the flexure away from a flapper, permitting the flapper to move toward a nozzle. The resultant buildup of air pressure on the diaphragm of the control relay at the lower right closes the exhaust port and opens the supply port to allow air at fully supply pressure to pass to the actuator. The valve stem motion rotates the flexure and thereby shifts the tip touching the flapper. The flapper assumes an equilibrium position proportional to the signal air pressure.

The pneumatic amplifier or booster is a special kind of regulator valve that develops an output air pressure proportional to the input signal pressure. It can be used to boost pressure on an actuator for faster action in cases where the instrument tubing is small-bore and long and the actuator volume is large.

## FURTHER READING

*ISA Handbook of Control Valves*, Instrument Society of America, Pittsburgh, 1971.

# **PUMP SYSTEMS**

---

---

# SECTION 8.1

---

# GENERAL CHARACTERISTICS OF PUMPING SYSTEMS AND SYSTEM-HEAD CURVES

---

J. P. MESSINA

## **SYSTEM CHARACTERISTICS AND PUMP HEAD**

---

A pump is used to deliver a specified rate of flow through a particular system. When a pump is to be purchased, this required capacity must be specified along with the total head necessary to overcome resistance flow and to meet the pressure requirements of the system components. The total head rating of a centrifugal pump is usually measured in feet (meters), and the differential pressure rating of a positive displacement pump is usually measured in pounds per square inch (kilopascals or bar<sup>1</sup>). Both express, in equivalent terms, the work in foot-pounds (newton-meters) the pump is capable of doing on each unit weight (force) of liquid pumped at the rated flow.<sup>2</sup> It is the responsibility of the purchaser to determine the required pump total head so the supplier can make a proper pump selection. Underestimating the total head required will result in a centrifugal pump's delivering less than the desired flow through the system. An underestimate of the differential pressure required will result in a positive displacement pump's using more power than estimated, and the design pressure limit of the pump could be exceeded. Therefore, system pressure and resistance to flow, which are dependent on system characteristics, dictate the required pump head rating.

## **THE PUMPING SYSTEM**

---

The piping and equipment through which the liquid flows to and from the pump constitute the pumping system. Only the length of the piping containing liquid controlled by the

<sup>1</sup>1 bar = 1<sup>5</sup> Pa.

<sup>2</sup>Work per unit weight mass, rather than weight force, is sometimes called *specific delivery work*; it has the units of newton-meters per kilogram and is equal to total head multiplied by *g*, the gravitation constant.

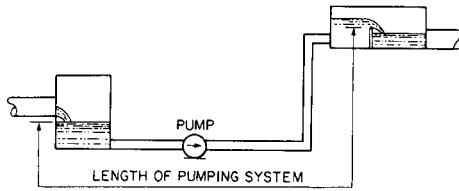


FIGURE 1 Length of system controlled by pump

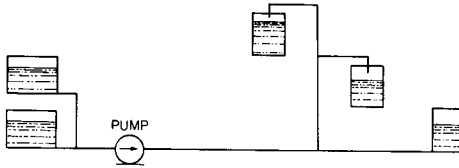


FIGURE 2 Branch-line pumping system

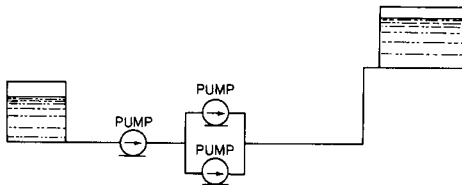


FIGURE 3 Pumps in series and in parallel

action of the pump is considered part of the system. A pump and the limit of its system length are shown in Figure 1.

The pump suction and discharge piping can consist of branch lines, as shown in Figure 2. There can be more than one pump in a pumping system. Several pumps can be piped together in series or in parallel or both, as shown in Figure 3. When there is more than one pump, the flow through the system is determined by the combined performance of all the pumps.

The system through which the liquid is pumped offers resistance to flow for several reasons. Flow through pipes is impeded by friction. If the liquid discharges to a higher elevation or a higher pressure, additional resistance is encountered. The pump must therefore overcome the total system resistance due to friction and, as required, produce an increase in elevation or pressure at the desired rate of flow. System requirements may be such that the pump discharges to a lower elevation or pressure but additional pump head is still required to overcome pipe friction and obtain the desired rate of flow.

### **ENERGY IN AN INCOMPRESSIBLE LIQUID**

The work done by a pump is the difference between the energy level at the point where the liquid leaves the pump and the energy level at the point where the liquid enters the pump. Work is also the amount of energy added to the liquid in the system. The total energy at any point in a pumping system is a relative term and is measured relative to some arbitrarily selected datum plane.

An incompressible liquid can have energy in the form of velocity, pressure, or elevation. Energy in various forms is added to the liquid as it passes through the pump, and the total energy added is constantly increasing with flow. It is appropriate then to speak of the energy added by a pump as the energy added per unit of weight (force) of the liquid pumped, and the units of energy expressed this way are foot-pounds per pound (newton-meters per newton) or just feet (meters). Therefore, when adding together the energies in their various forms at some point, it is necessary to express each quantity in common equivalent units of feet (meters) of *head*.

Liquid flowing in a conduit can undergo changes in energy form. Bernoulli's theorem for an incompressible liquid states that in steady flow, without losses, the energy at any point in the conduit is the sum of the *velocity head*, *pressure head*, and *elevation head* and that this sum is constant along a streamline in the conduit. Therefore, the energy at any point in the system relative to a selected datum plane is

$$H = \frac{V^2}{2g} + \frac{p}{\gamma} + Z \quad (1)$$

where  $H$  = energy (total head) of system, ft · lb/lb or ft (N · m/N or m)

$V$  = velocity, ft/s (m/s)

$g$  = acceleration of gravity, 32.17 ft/s<sup>2</sup> (9.807 m/s<sup>2</sup>)

$p$  = pressure, lb/ft<sup>2</sup> (N/m<sup>2</sup>)

$\gamma$  = specific weight (force) of liquid, lb/ft<sup>3</sup> (N/m<sup>3</sup>)

$Z$  = elevation above (+) or below (-) datum plane, ft (m)

The velocity and pressure at the point of energy measurement are expressed in units of *equivalent head* and are added to the distance  $Z$  that this point is above or below the selected datum plane. If pressure is measured as gage (relative to atmosphere), total head  $H$  is gage; if pressure is measured as absolute, total head  $H$  is absolute. Equation 1 can also be applied to liquid at rest in a vertical column or in a large vessel (or to liquids of various densities) to account for changes in pressure with changes in elevation or vice versa.

The equivalent of velocity and pressure energy heads in feet (meters) can be thought of as the height to which a vessel of liquid of constant density has to be filled, above the point of measurement, to create this same velocity or pressure. This is illustrated in Figure 4 and further explained in the following text.

**Velocity Head** The kinetic energy in a mass of flowing liquid is  $\frac{1}{2} mV^2$  or  $\frac{1}{2} (W/g)V^2$ . The kinetic energy per unit weight (force) of this liquid is  $\frac{1}{2} (WV^2/Wg)$ , or  $V^2/2g$ , measured in feet (meters). This quantity is theoretically equal to the equivalent static head of liquid that is required in a vessel above an opening if the discharge is to have a velocity equal to  $V$ . This is also the theoretical height the jet of liquid would rise if it were discharging vertically upward from an orifice.

A free-falling particle in a vacuum acquires the velocity  $V$  starting from rest after falling a distance  $H$ . Also

$$V = \sqrt{2gH}$$

All liquid particles moving with the same velocity have the same velocity head, regardless of specific weight. The velocity of liquid in pipes and open channels invariably varies across any one section of the conduit. However, when calculating system resistance it is sufficiently accurate to use the average velocity, computed by dividing the flow rate by the cross-sectional area of the conduit, when substituting in the term  $V^2/2g$ .

**Pressure Head** The pressure head, or flow work, in a liquid is  $p/\gamma$ , with units in feet (meters). A liquid, having pressure, is capable of doing work, for example, on a piston having an area  $A$  and stroke  $L$ . The quantity of liquid required to complete one stroke is  $\gamma AL$ . The work (force × stroke) per unit weight (force) is  $pAL/\gamma AL$ , or  $p/\gamma$ . The work a pump



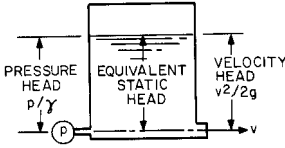


FIGURE 4 Equivalent static head

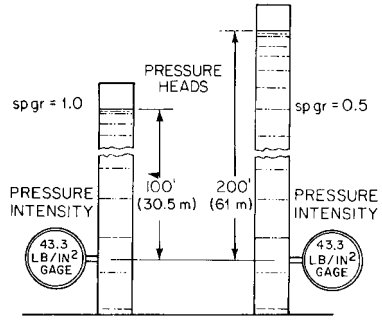


FIGURE 5 Liquids of different specific weights (also specific gravities) require different column heights or pressure heads to produce the same pressure intensity (43.3 lb/in<sup>2</sup> = 298.5 kPa).

must do to produce pressure intensity in liquids having different specific weights varies inversely with the specific weight or specific gravity of the liquid. Figure 5 illustrates this point for liquids having specific gravities of 1.0 and 0.5. The less dense liquid must be raised to a higher column height to produce the same pressure as the denser liquid. The pressure at the bottom of each liquid column  $H$  is the weight of the liquid above the point of pressure measurement divided by the cross-sectional area  $A$  at the same point,  $AH\gamma/A$ , which is simply  $H\gamma$ . Note that in this discussion  $A$  is in square feet (square meters) and  $L$  and  $H$  are in feet (meters).

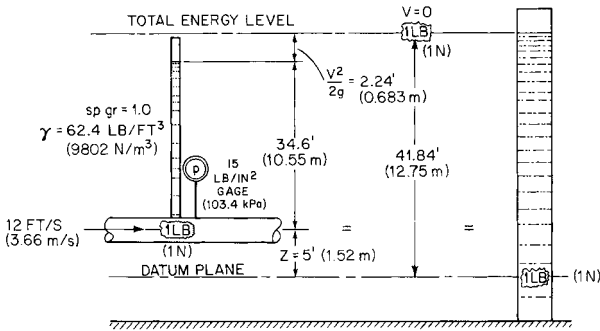
The height of the liquid column in feet (meters) above the point of pressure measurement, if the column is of constant density, is equivalent pressure static head. When pressure intensity  $AH\gamma/A$  is substituted for  $p$  in  $p/\gamma$ , it can be seen that the pressure head  $H$  is the liquid column height. Therefore, at the base of equal columns containing different liquids (with equal surface pressures), the pressure heads in feet (meters) are the same but the intensities in pounds per square foot (newtons per square meter) are different. For this reason, it is necessary to identify the liquids when comparing pressure heads.

**Elevation Head** The elevation energy, or potential energy, in a liquid is the distance  $Z$  in feet (meters) measured vertically above or below an arbitrarily selected horizontal datum plane. Liquid above a reference datum plane has positive potential energy because it can fall a distance  $Z$  and acquire kinetic energy or vertical head equal to  $Z$ . Also, it requires  $WZ$  ft · lb ( $N \cdot m$ ) of work to raise  $W$  lb ( $N$ ) of liquid above the datum plane. The work per unit weight (force) of liquid is therefore  $WZ/W$ , or  $Z$  ft (m). In a pumping system, the energy required to raise a liquid above a reference datum plane can be thought of as being provided by a pump located at the datum elevation and producing a pressure that will support the total weight of the liquid in a pipe between the pump discharge and the point in the pipe to which the liquid is to be raised. This pressure is  $AZ\gamma/A$ , or simply  $Z\gamma$  lb/ft<sup>2</sup> ( $N/m^2$ ) or  $Z\gamma/144$  lb/in<sup>2</sup>. Because head is equal to pressure divided by specific weight, elevation head is  $Z\gamma/\gamma$ , or  $Z$  ft.

Liquid below the reference datum plane has negative elevation head.

**Total Head** Figure 6 illustrates a liquid under pressure in a pipe. To determine the total head at the pressure gage connection and relative to the datum plane, Eq. 1 may be used (assume that the gage is at the pipe centerline):

$$H = \frac{V^2}{2g} + \frac{p}{\gamma} + Z$$



**FIGURE 6** The total head, or energy, in foot-pounds per pound (newtonmeters per newton) is equal to the sum of the velocity, pressure, and elevation heads relative to a datum place. A unit weight (force) of the same liquid or any liquid raised to rest at the height shown, or under a column of liquid of this same height, has the same head as the unit weight (force) of liquid shown flowing in the pipe.

In USCS units

$$H = \frac{12^2}{2 \times 32.17} + \frac{144 \times 15}{62.4} + 5$$

$$= 2.24 + 34.6 + 5$$

$$= 41.84 \text{ ft} \cdot \text{lb/lb, or ft}$$

In SI units

$$H = \frac{3.66^2}{2 \times 9.807} + \frac{103.4 \times 1000}{9802} + 1.52$$

$$= 0.683 + 10.55 + 1.52$$

$$= 12.75 \text{ N} \cdot \text{m/N, or m}$$

The total head may also be calculated using the expression

$$H = \frac{V^2}{2g} + \text{manometer height} + Z$$

In USCS units

$$H = 2.24 + 34.6 + 5$$

$$= 41.84 \text{ ft} \cdot \text{lb/lb, or ft}$$

In SI units

$$H = 0.683 + 10.55 + 1.52$$

$$= 12.75 \text{ N} \cdot \text{m/N, or m}$$

The total head of 41.84 ft (12.75 m) is equivalent to 1 lb (N) of the liquid raised 41.84 ft (12.75 m) above the datum plane (zero velocity) or the pressure head of 1 lb (N) of the liquid under a column height of 41.84 ft (12.75 m) measured at the datum plane.

The gage pressure  $p$ , and consequently the pressure head, are measured relative to atmospheric pressure. Gage pressure head can therefore be a positive or a negative quantity. The pressure may also be expressed as an absolute pressure (measured from complete vacuum). Therefore, when velocity, pressure, and elevation heads are combined to obtain the total energy at a point, it should be clearly stated that the total head is either feet (meters) gage or feet (meters) absolute with respect to the datum plane.

The pressure or velocity of a liquid may at times be given as a pressure head of a liquid having a density different from the density of the liquid being pumped. In the total head, that is, the sum of the pressure, velocity, and elevation heads, the components must be corrected to be equal to the head of the liquid being pumped. For example, if the pressure is measured by a manometer to be 24 in (61 cm) of mercury (sp. gr. = 13.6) absolute,

the pressure head, or energy, in foot-pounds per pound (newton-meters per newton) of water pumped at 60°F (15.6°C) is found as follows.

Let subscripts 1 and 2 denote different liquids or, in this example, mercury and water, respectively:

$$h_1 = \frac{p_1}{\gamma_1}$$

$$p_1 = h_1 \gamma_1 = p_2$$

$$h_2 = \frac{p_2}{\gamma_2} = \frac{h_1 \gamma_1}{\gamma_2}$$

$$= \frac{\gamma_1}{\gamma_2} h_1 \quad (2)$$

$$= \frac{\text{sp. gr.}_1}{\text{sp. gr.}_2} h_1 \quad (3)$$

Therefore

in USCS units 
$$h_2 = \frac{13.6}{1} \times \frac{24}{12} = 27.2 \text{ ft abs}$$

in SI units 
$$h_2 = \frac{13.6}{1} \times \frac{61}{100} = 8.3 \text{ m abs}$$

Also,  $h_2 = (27.2 - 13.6) \left(\frac{30}{12}\right) = -6.8 \text{ ft}$  [ $(8.3 - 13.6) \left(\frac{76}{100}\right) = -2.04 \text{ m}$ ] gage if corrected to a standard barometer of 30 in (76 cm) of mercury.

## PUMP TOTAL HEAD

The total head of a pump is the difference between the energy level at the pump discharge (point 2) and that at the pump suction (point 1), as shown in Figures 7 and 8. Applying Bernoulli's equation (Eq. 1) at each point, the pump total head  $TH$  in feet (meters) becomes

$$TH = H_d - H_s = \left( \frac{V_d^2}{2g} + \frac{p_d}{\gamma_d} + Z_d \right) - \left( \frac{V_s^2}{2g} + \frac{p_s}{\gamma_s} + Z_s \right) \quad (4)$$

The equation for pump differential pressure  $P_\Delta$  in pounds per square foot (newtons per square meter) is

$$P_\Delta = P_d - P_s = \left[ p_d + \gamma_d \left( Z_d + \frac{V_d^2}{2g} \right) \right] - \left[ p_s + \gamma_s \left( Z_s + \frac{V_s^2}{2g} \right) \right] \quad (5)$$

$$P_\Delta \text{ in lb/in}^2 = P_\Delta \text{ in lb/ft}^2 \div 144$$

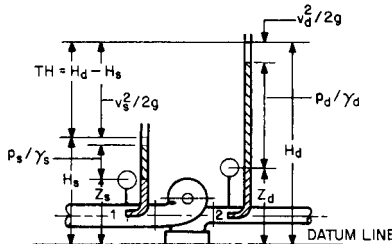


FIGURE 7 Centrifugal pump total head

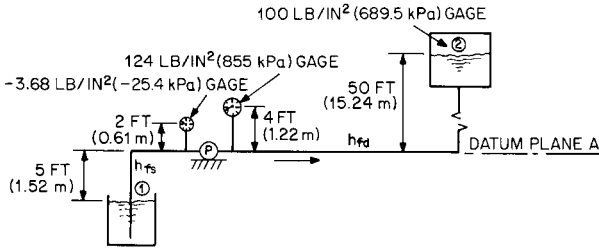


FIGURE 8 Example 1

where the subscripts  $d$  and  $s$  denote discharge and suction, respectively, and

$H$  = total head of system, (+) or (-) ft (m) gage or (+) ft (m) abs

$P$  = total pressure of system, (+) or (-) lb/ft<sup>2</sup> (N/m<sup>2</sup>) gage or (+) lb/ft<sup>2</sup> (N/m<sup>2</sup>) abs

$V$  = velocity, ft/s (m/s)

$p$  = pressure, (+) or (-) lb/ft<sup>2</sup> (N/m<sup>2</sup>) gage or (+) lb/ft<sup>2</sup> (N/m<sup>2</sup>) abs

$Z$  = elevation above (+) or below (-) datum plane, ft (m)

$\gamma$  = specific weight (force) of liquid, lb/ft<sup>3</sup> (N/m<sup>3</sup>)

$g$  = acceleration of gravity, 32.17 ft/s<sup>2</sup> (9.807 m/s<sup>2</sup>)

Pump total head  $TH$  and pump differential pressure  $P_{\Delta}$  are always absolute quantities because either gage pressures or absolute pressures but not both are used at the discharge and suction connections of the pump and a common datum plane is selected.

Pump total head in feet (meters) and pump differential pressure in pounds per square foot (newtons per square meter) are related to each other as

$$TH = \frac{P_{\Delta}}{\gamma} \quad (6)$$

It is very important to note that, if the rated total head of a centrifugal pump is given in feet (meters), this head can be imparted to *all* individual liquids pumped at the rated capacity and speed, regardless of the specific weight (force) of the liquids as long as their viscosities are approximately the same. A pump handling different liquids of approximately the same viscosity will generate the same total head but will not produce the same differential pressure, nor will the power required to drive the pump be the same. On the other hand, a centrifugal pump rated in pressure units would have to have a different pressure rating for each liquid of different specific weight (force). In this section, pump total head will be expressed in feet (meters), the usual way of rating centrifugal pumps. For an explanation of positive displacement pump differential pressure, its use and relationship to pump total head, see Chapter 3.

Pump total head can be measured by installing gages at the pump suction and discharge connections and then substituting these gage readings into Eq. 4. Pump total head may also be found by measuring the energy difference between any two points in the pumping system, one on each side of the pump, providing all losses (other than pump losses) between these points are credited to the pump and added to the energy head difference. Therefore, between any two points in a pumping system where the energy is added only by the pump and the specific weight (force) of the liquid does not change (for example, as a result of temperature), the following general equation for determining pump total head applies:

$$\begin{aligned} TH &= (H_2 - H_1) + \Sigma h_{f(1-2)} \\ &= \left( \frac{V_2^2}{2g} + \frac{p_2}{\gamma} + Z_2 \right) - \left( \frac{V_1^2}{2g} + \frac{p_1}{\gamma} + Z_1 \right) + \Sigma h_{f(1-2)} \end{aligned} \quad (7)$$

where the subscripts 1 and 2 denote points in the pumping system anyplace upstream and downstream from the pump, respectively, and

$H$  = total head of system, (+) or (-) ft (m) gage or (+) ft (m) abs

$V$  = velocity, ft/s (m/s)

$p$  = pressure, (+) or (-) lb/in<sup>2</sup> (N/m<sup>2</sup>) gage or (+) lb/in<sup>2</sup> (N/m<sup>2</sup>) abs

$Z$  = elevation above (+) or below (-) datum plane, ft (m)

$\gamma$  = specific weight (force) of liquid (assumed the same between points), lb/ft<sup>3</sup> (N/m<sup>3</sup>)

$g$  = acceleration of gravity, 32.17 ft/s<sup>2</sup> (9.807 m/s<sup>2</sup>)

$\Sigma h_f$  = sum of piping losses between points, ft (m)

When the specific gravity of the liquid is known, the pressure head may be calculated from the following relationships:

$$\text{In feet} \quad \frac{p}{\gamma} = \frac{0.016 \text{ lb/ft}^2}{\text{sp. gr.}} \text{ or } \frac{2.3 \text{ lb/in}^2}{\text{sp. gr.}} \quad (8a)$$

$$\text{In meters} \quad \frac{p}{\gamma} = \frac{0.102 \text{ kPa}}{\text{sp. gr.}} \text{ or } \frac{1.02 \times 10^{-3} \text{ bar}}{\text{sp. gr.}} \quad (8b)$$

The velocity in a pipe may be calculated as follows:

$$\text{In feet per second} \quad V = \frac{(\text{gm})(0.408)}{(\text{pipe ID in inches})^2} \quad (9a)$$

$$\text{In meters per second} \quad V = \frac{(\text{m}^3/\text{h})(3.54)}{(\text{pipe ID in cm})^2} \text{ or } \frac{(\text{liters/s})(12.7)}{(\text{pipe ID in cm})^2} \quad (9b)$$

The following example illustrates the use of Eqs. 4 and 7 for determining pump total head.

**EXAMPLE 1** A centrifugal pump delivers 1000 gpm (227 m<sup>3</sup>/hr) of liquid of specific gravity 0.8 from the suction tank to the discharge tank through the piping shown in Figure 8. (a) Calculate pump total head using gages and the datum plane selected. (b) Calculate total head using the pressures at points 1 and 2 and the same datum plane as (a).

*Given:* Suction pipe ID = 8 in (203 mm), discharge pipe ID = 6 in (152 mm),  $h_f$  = pipe, valve, and fitting losses,  $h_{fs} = 3$  ft (0.91 m),  $h_{fd} = 25$  ft (7.62 m).

$$\text{In USCS units} \quad \text{Calculated pipe velocity} = \frac{(\text{gpm})(0.408)}{(\text{ID in inches})^2}$$

$$V_s = \frac{1000 \times 0.408}{8^2} = 6.38 \text{ ft/s}$$

$$V_d = \frac{1000 \times 0.408}{6^2} = 11.33 \text{ ft/s}$$

$$\text{In SI units} \quad \text{Calculated pipe velocity} = \frac{(\text{m}^3/\text{h})(3.54)}{(\text{ID in cm})^2}$$

$$V_s = \frac{227 \times 3.54}{20.3^2} = 1.95 \text{ m/s}$$

$$V_d = \frac{227 \times 3.54}{15.2^2} = 3.48 \text{ m/s}$$

(a) From Eq. 4,

$$TH = \left( \frac{V_d^2}{2g} + \frac{p_d}{\gamma_d} + Z_d \right) - \left( \frac{V_s^2}{2g} + \frac{p_s}{\gamma_s} + Z_s \right)$$

and Eq. 8,

$$\text{in USCS units} \quad \frac{p}{\gamma} = \frac{2.31 \text{ lb/in}^2}{\text{sp. gr.}}$$

$$\text{in SI units} \quad \frac{p}{\gamma} = \frac{0.102 \text{ kPa}}{\text{sp. gr.}}$$

Therefore,

in USCS units

$$\begin{aligned} TH &= \left( \frac{11.33^2}{2 \times 32.3} + \frac{2.31 \times 124}{0.8} + 4 \right) - \left( \frac{638^2}{2 \times 32.2} + \frac{2.31(-3.68)}{0.8} + 2 \right) \\ &= 364 - (-8) = 372 \text{ ft} \cdot \text{lb/lb, or ft} \end{aligned}$$

In SI units

$$\begin{aligned} TH &= \left( \frac{3.48^2}{2 \times 9.807} + \frac{0.102 \times 855}{0.8} + 1.22 \right) - \left( \frac{195^2}{2 \times 9.807} + \frac{0.102(-25.4)}{0.8} + 2 \right) \\ &= 110.9 - (-2.43) = 113.3 \text{ N} \cdot \text{m/N, or m} \end{aligned}$$

(b) from Eq. 7,

$$TH = \left( \frac{V_2^2}{2g} + \frac{p_2}{\gamma} + Z_2 \right) - \left( \frac{V_1^2}{2g} + \frac{p_1}{\gamma} + Z_1 \right) + \Sigma h_{f(1-2)}$$

and Eq. 8,

$$\text{in USCS units} \quad \frac{p}{\gamma} = \frac{2.31 \text{ lb/in}^2}{\text{sp. gr.}}$$

$$\text{in SI units} \quad \frac{p}{\gamma} = \frac{0.102 \text{ kPa}}{\text{sp. gr.}}$$

Therefore

$$\begin{aligned} \text{in USCS units} \quad TH &= \left( 0 + \frac{2.31 \times 100}{0.8} + 50 \right) - (0 + 0 - 5) + (3 + 25) \\ &= 399 - (-5) + 28 = 372 \text{ ft} \cdot \text{lb/lb, or ft} \end{aligned}$$

in SI units

$$\begin{aligned}
 TH &= \left( 0 + \frac{0.102 \times 689.5}{0.8} + 15.24 \right) - (0 + 0 - 1.52) + (0.91 + 7.62) \\
 &= 103.2 - (-1.52) + 8.53 = 113.3 \text{ N} \cdot \text{m/N, or m}
 \end{aligned}$$

## ENERGY AND HYDRAULIC GRADIENT

The total energy at any point in a pumping system may be calculated for a particular rate of flow using Bernoulli's equation (Eq. 1). If some convenient datum plane is selected and the total energy, or head, at various locations along the system is plotted to scale, the line drawn through these points is called the *energy gradient*. Figure 9 shows the variation in total energy  $H$  measured in feet (meters) from the suction liquid surface point 3 to the discharge liquid surface point 4. A horizontal energy gradient indicates no loss of head.

The line drawn through the sum of the pressure and elevation heads at various points represents the pressure variation in flow measured above the datum plane. It also represents the height the liquid would rise in vertical columns relative to the datum plane when the columns are placed at various locations along pipes having positive pressure anywhere in the system. This line, shown dotted in Figure 9, is called the *hydraulic gradient*. The difference between the energy gradient line and the hydraulic gradient line is the velocity head in the pipe at that point.

The pump total head is the algebraic difference between the total energy at the pump discharge (point 2) and the total energy at the pump suction (point 1).

## SYSTEM-HEAD CURVES

A pumping system may consist of piping, valves, fittings, open channels, vessels, nozzles, weirs, meters, process equipment, and other liquid-handling conduits through which flow is required for various reasons. When a particular system is being analyzed for the pur-

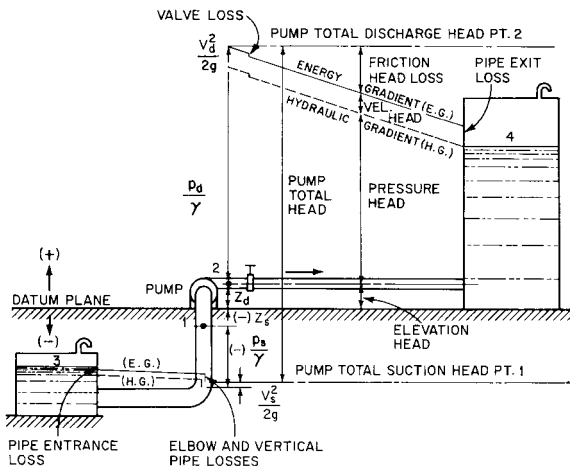


FIGURE 9 Energy and hydraulic gradients

pose of selecting a pump or pumps, the resistance to flow of the liquid through these various components must be calculated. It will be explained in more detail later in this section that the resistance increases with flow at a rate approximately equal to the square of the flow through the system. In addition to overcoming flow resistance, it may be necessary to add head to raise the liquid from suction level to a higher discharge level. In some systems the pressure at the discharge liquid surface may be higher than the pressure at the suction liquid surface, a condition that requires more pumping head. The latter two heads are *fixed system heads*, as they do not vary with rate of flow. Fixed system heads can also be negative, as would be the case if the discharge level elevation or the pressure above that level were lower than suction elevation or pressure. Fixed system heads are also called *static heads*.

A system-head curve is a plot of total system resistance, variable plus fixed, for various flow rates. It has many uses in centrifugal pump applications. It is preferable to express system head in feet (meters) rather than in pressure units because centrifugal pumps are rated in feet (meters), as previously explained. System-head curves usually show flow in gallons per minute, but when large quantities are involved, the units of cubic feet per second or million gallons per day are used. Although the standard SI units for volumetric flow are cubic meters per second, the units of cubic meters per hour are more common.

When the system head is required for several flows or when the pump flow is to be determined, a system-head curve is constructed using the following procedure. Define the pumping system and its length. Calculate (or measure) the fixed system head, which is the net change in total energy from the beginning to the end of the system due to elevation or pressure head differences. An increase in head in the direction of flow is a positive quantity. Next, calculate, for several flow rates, the variable system total head loss through all piping, valves fittings, and equipment in the system. As an example, see Figure 10, in which the pumping system is defined as starting at point 1 and ending at point 2. The fixed system head is the net change in total energy. The total head at point 1 is  $p_s/\gamma$ , and that at point 2 is  $p_d/\gamma + Z$ . The pressure and liquid levels do not vary with flow. The variable system head is pipe friction (including valves and fittings). The fixed head and variable heads for several flow rates are added together, resulting in a curve of total system head versus flow.

The flow produced by a centrifugal pump varies with the system head, whereas the flow of a positive displacement pump is independent of the system head. By superimposing the head-capacity characteristic curve of a centrifugal pump on a system-head curve, as shown in Figure 10, the flow of a pump can be determined. The curves will intersect at the flow rate of the pump, as this is the point at which the pump head is equal to the required system

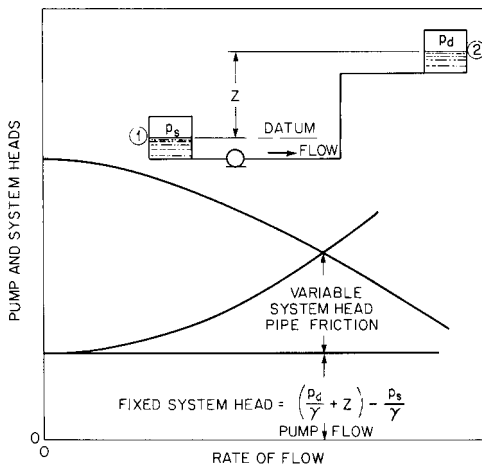


FIGURE 10 Construction of system total-head curve



head for the same flow. When a pump is being purchased, it should be specified that the pump head-capacity curve intersect the system-head curve at the desired flow rate. This intersection should be at the pump's best efficiency capacity or very close to it.

The system-head curve for Example 1 is shown in Figure 11. This assumes that the suction and discharge liquid levels are 5 ft (1.5 m) below and 50 ft (15 m) above the datum plane, respectively, and do not vary with flow. The pressure in the discharge tank is also independent of flow and is 100 lb/in<sup>2</sup> (689.5 kPa) gage. These values are therefore fixed system heads. The pipe and fitting losses are assumed to vary with flow as a square function. The length of the pumping system is from point 1 to point 2. The difference in heads at these points plus the frictional losses at various flow rates are the total system head and the head required by a pump for the different flows. It is necessary to calculate the total system head for only one flow rate—say, design—which in this example is 1000 gpm (227 m<sup>3</sup>/h). The total head at other flow conditions is the fixed system head plus the variable system head multiplied by  $(\text{gpm}/1000)^2$  ( $\text{m}^3/\text{h} \div 227$ )<sup>2</sup>. If Example 1 is an existing system, the total head may be calculated by using gages at the pump suction and discharge connections. The total head measured will then be the head at the intersection of the pump and system curves, as shown in Figure 11. In this example, a correctly purchased pump would produce a total head of 372 ft (113 m) at the design flow of 1000 gpm (227 m<sup>3</sup>/h).

In systems that are open-ended and in which there is a decrease in elevation from inlet to outlet, a portion of the system-head curve will be negative (Figure 12). In this example, the pump is used to increase gravity flow. Without a pump in the system, the negative resistance, or static head, is the driving head that moves the liquid through the system. Steady-state gravity flow is sustained at the flow rate corresponding to zero total system head (negative static head plus system resistance equals zero). If a flow is required at any rate greater than that which gravity can produce, a pump is required to overcome the additional system resistance.

For additional information concerning the construction of system-head curves for flow in branch lines, refer to Section 8.2.

## VARIANTS IN PUMPING SYSTEMS

For a fixed set of conditions in a pumping system, there is just one total head for each flow rate. Consequently, a centrifugal pump operating at a constant speed can deliver just one flow. In practice, however, conditions in a system vary as a result of either controllable or uncontrollable changes. Changes in the valve opening in the pump discharge or bypass line, changes in the suction or discharge liquid level, changes in the pressures at these levels, the aging of pipes, changes in the process, changes in the number of pumps pumping

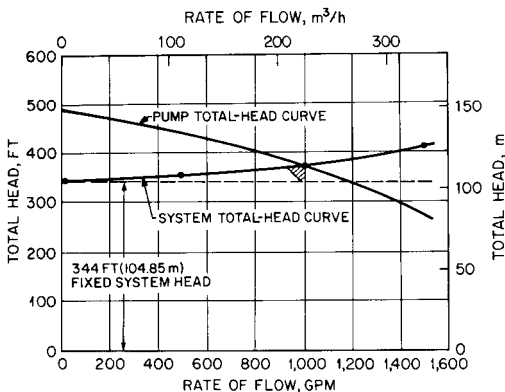


FIGURE 11 System total-head curve for Example 1

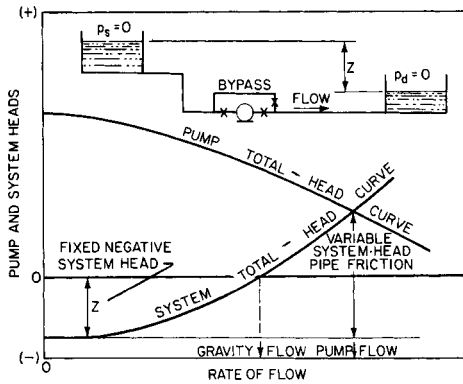


FIGURE 12 Construction of system total-head curve to determine gravity flow and centrifugal pump flow

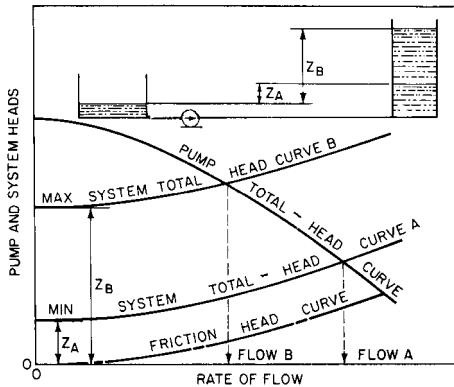


FIGURE 13 Construction of system total-head curves for a pumping system having variable static head

into a common header, changes in the size, length, or number of pipes are all examples of either controllable or uncontrollable system changes. These changes in system conditions alter the shape of the system-head curve and, in turn, affect pump flow.

Methods of constructing system-head curves and determining the resultant pump flows for two of the more common of these variants are explained here.

**Variable Static Head** In a system where a pump is taking suction from one reservoir and filling another, the capacity of a centrifugal pump will decrease with an increase in static head. The system-head curve is constructed by plotting the variable system friction head versus flow for the piping. To this is added the anticipated minimum and maximum static heads (difference in discharge and suction levels). The resulting two curves are the total system heads for each condition. The flow rate of the pump is the point of intersection of the pump head-capacity curve with either one of the latter two system-head curves or with any intermediate system-head curve for other level conditions. A typical head versus flow curve for a varying static head system is shown in Figure 13.

If it is desired to maintain a constant pump flow for different static head conditions, the pump speed can be varied to adjust for an increase or decrease in the total system head. A typical variable-speed centrifugal pump operating in a varying static head system can have a constant flow, as shown in Figure 14.

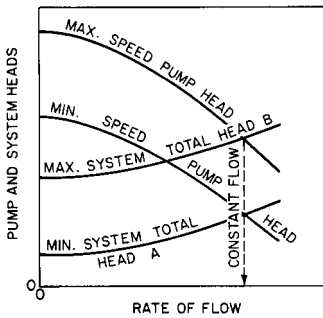


FIGURE 14 Varying centrifugal pump speed to maintain constant flow for the different reservoir levels shown in Figure 13

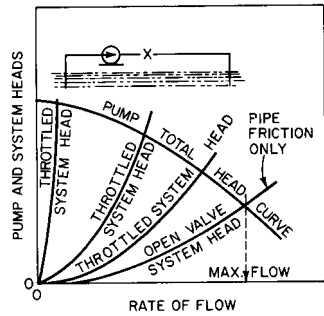


FIGURE 15 Construction of system total-head curves for various valve openings

It is important to select a pump that will have its best efficiency within the operating range of the system and preferably at the condition at which the pump will operate most often.

**Variable System Resistance** A valve or valves in the discharge line of a centrifugal pump alter the variable frictional head portion of the total system-head curve and consequently the pump flow. Figure 15, for example, illustrates the use of a discharge valve to change the system head for the purpose of varying pump flow during a shop performance test. The maximum flow is obtained with a completely open valve, and the only resistance to flow is the friction in the piping, fittings, and flowmeter. A closed valve results in the pump's operating at shutoff conditions and produces maximum head. Any flow between maximum and shutoff can be obtained by proper adjustment of the valve opening.

### ***DIVIDING TOTAL HEAD AND SYSTEM-HEAD CURVES FOR CENTRIFUGAL PUMPS IN SERIES***

Pump limitations or system component requirements may determine that two or more pumps must be used in series. There are practical limitations as to the maximum head that can be developed in a single pump, even if multistaged. When pumping through several system components, there may be pressure limitations that prevent using a single pump to develop all of the head required at the beginning of the system. If several pumps are to be used in series, how should the total head be divided among them?

The sum of the total heads of the pumps must be equal to the required total system head at the design flow. Although mathematically any division of the total head among the pumps to be used is possible (at long as the sum of the pump heads is equal to the total system head), the actual pressure required at various locations along the system flow path determines how the pumping heads are to be divided. An energy or pressure gradient should be drawn for the system. The number of pumps, their locations, and their total heads should be selected to produce the desired pressures (or range of pressures) at critical locations along the system. In addition to considering the pressure loss through components to overcome resistance to flow, consideration should also be given to the minimum pressures required to prevent flashing in piping, cavitation at pump inlets, and so on, as well as the maximum working pressures for different parts of the system.

If preferred, the total system can be divided into subsystems, one for each pump (or group of pumps). The end of one subsystem and the beginning of another can be selected anywhere between pumps in series because the pump total head will be unaffected by the division line. Consequently, several system-head curves can be drawn for specification and

purchasing purposes—for example, primary condensate pump system, secondary condensate pump system, feed pump system, in a total power plant system.

## TRANSIENTS IN SYSTEM HEADS

---

During the starting of a centrifugal pump and prior to the time normal flow is reached, certain transient conditions can produce or require heads and consequently torques much higher than design. In some cases, the selection of the driver and the pump must be based on starting rather than normal flow conditions.

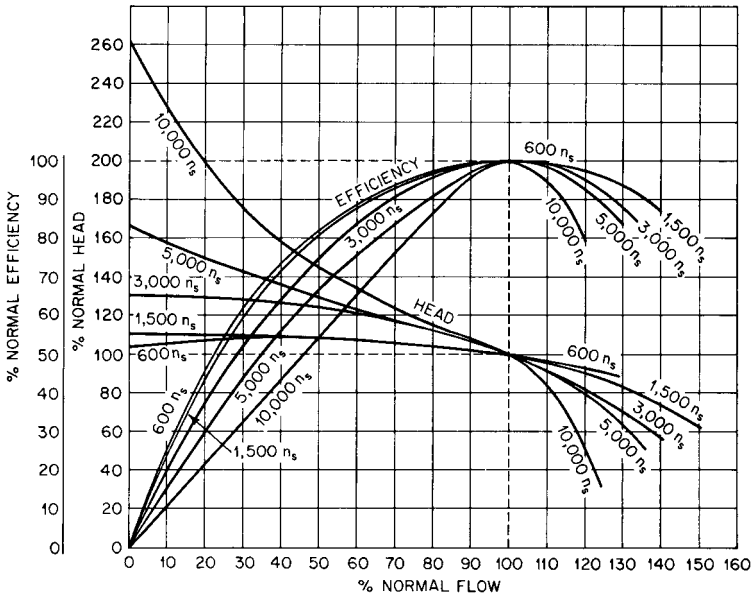
Low- and medium-specific-speed pumps of the radial- and mixed-flow types (less than approximately 5000 specific speed, rpm, gpm, ft units) have favorable starting characteristics. The pump head at shutoff is not significantly higher than that at normal flow, and the shutoff torque is less than that at normal flow. High-specific-speed pumps of the mixed- and axial-flow types (greater than approximately 5000 specific speed) develop relatively high shutoff heads, and their shutoff torque is greater than that at normal flow. These characteristics of high-specific-speed pumps require special attention during the starting period. Characteristics of pumps of different specific speeds are shown in Figures 16a and 16b.

**Starting Against a Closed Valve** When any centrifugal pump is started against a closed discharge valve, the pump head will be higher than normal. The shutoff head will vary with pump specific speed. As shown in Figure 16a, the higher the specific speed, the higher the shutoff head in percent of normal pump head. As a pump is accelerated from rest to full speed against a closed valve, the head on the pump at any speed is equal to the square of the ratio of the speed to the full speed times the shutoff head at full speed. Therefore, during starting, the head will vary from point *A* to point *E* in Figure 17. Points *B*, *C*, and *D* represent intermediate heads at intermediate speeds. The pump, the discharge valve, and any intermediate piping must be designed for maximum head at point *E*.

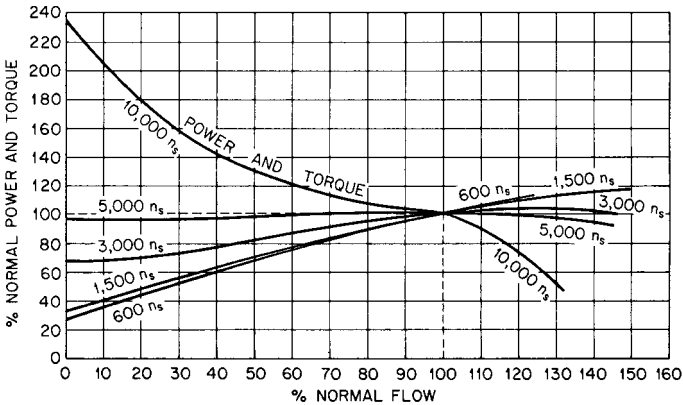
Pumps requiring less shutoff power and torque than at normal flow condition are usually started against a closed discharge valve. To prevent backflow from a static discharge head prior to starting, either a discharge shutoff valve, a check valve, or a broken siphon is required. When pumps are operated in parallel and are connected to a common discharge header that would permit flow from an operating pump to circulate back through an idle pump, a discharge valve or check valve must be used.

Figure 18 is a typical characteristic curve for a low-specific-speed pump. Figure 19 illustrates the variation of torque with pump speed when the pump is started against a closed discharge valve. The torque under shutoff conditions varies as the square of the ratio of speeds, similar to the variation in shutoff head, and is shown as curve *ABC*. At zero speed, the pump torque is not zero as a result of static friction in the pump bearings and stuffing box or boxes. This static friction is greater than the sum of running friction and power input to the impeller at very low speeds, which explains the dip in the pump torque curve between 0 and 10% speed. Also shown in Figure 19 is the speed-torque curve of a typical squirrel-cage induction motor. Note that the difference between motor and pump torque is the excess torque available to accelerate the pump from rest to full speed. During acceleration, the pump shaft must transmit not only the pump torque (curve *ABC*) but also the excess torque available in the motor. Therefore pump shaft torque follows the motor speed-torque curve less the torque required to accelerate the mass inertia ( $WK^2$ ) of the motor's rotor.

High-specific-speed pumps, especially propeller pumps, requiring more than normal torque at shutoff are not normally started with a closed discharge valve because larger and more expensive drivers would be required. These pumps will also produce relatively high pressures in the pump and in the system between pump and discharge valve. Figure 20 is a typical characteristic curve for a high-specific-speed pump. Curve *ABC* of Figure 21 illustrates the variation of torque with speed when this pump is started against a closed discharge valve. A typical speed-torque curve of a squirrel-cage induction motor sized for normal pump torque is also shown. Note that the motor has insufficient torque to accelerate to full speed and would remain overloaded at point *C* until the discharge valve on the

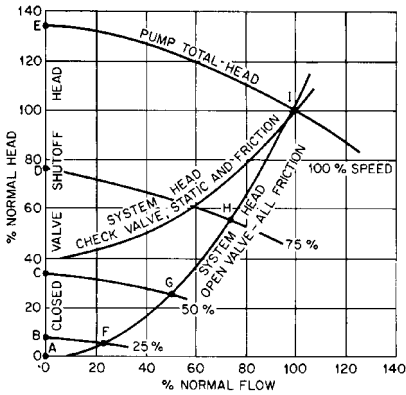


**FIGURE 16A** Approximate comparison of head and efficiency versus flow for impellers of different specific speeds in single-stage volute pumps. Specific speed  $n_s = \text{rpm} \sqrt{\text{gpm}/\text{TH}}$  in  $\text{ft}^{3/4}$   
 To convert to other units using  
 rpm,  $\text{m}^3/\text{s}$ , m: multiply by 0.01936; rpm,  $\text{m}^3/\text{h}$ , m: multiply by 1.163; rpm, L/s, m: multiply by 0.6123  
 To convert to the universal specific speed  $\Omega_s$  (defined in Section 2.1) divide  $n_s$  by 2733.

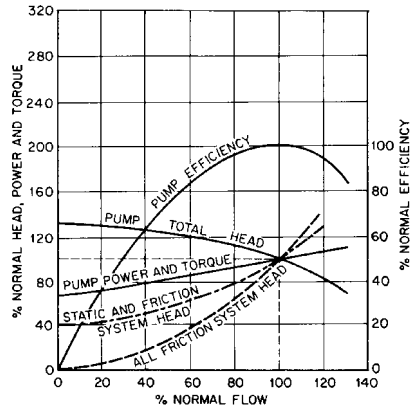


**FIGURE 16B** Approximate comparison of power and torque versus flow for impellers of different specific speeds in single-stage volute pumps

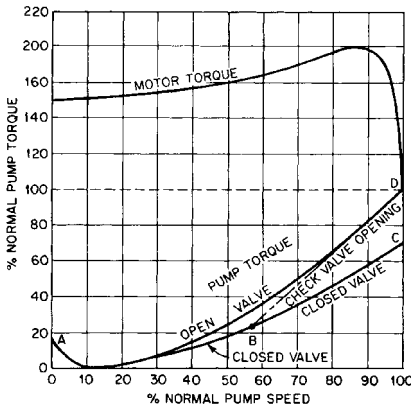
pump was opened. To avoid this situation, the discharge valve should be timed to open sufficiently to keep the motor from overloading when the pump reaches full speed. To accomplish this timing, it may be necessary to start opening the valve in advance of energizing the motor. Care should be taken not to start opening the discharge valve too soon because



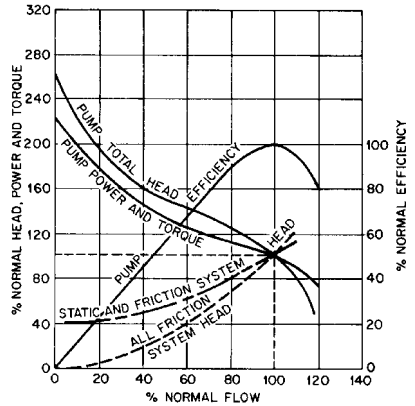
**FIGURE 17** Variation of head when a centrifugal pump is started with a closed valve, an open valve, and a check valve



**FIGURE 18** Typical constant-speed characteristic curves for a low-specific-speed pump



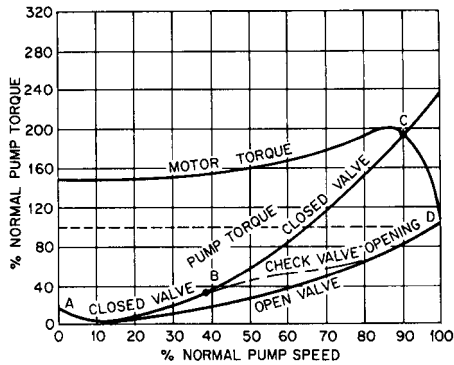
**FIGURE 19** Variation of torque during start-up of a low-specific-speed pump with a closed valve, an open valve, and a check valve. See Figure 18 for pump characteristics.



**FIGURE 20** Typical constant-speed characteristic curves for a high-specific-speed pump

this would cause excessive reverse flow through the pump and require the motor to start under adverse reverse-speed conditions. If the driver is a synchronous motor, additional torque at pull-in speed is required, over and above that needed to overcome system head and accelerate the pump and driver rotors from rest. At the critical pull-in point, sufficient torque must be available to pull the load into synchronism in the prescribed time. A synchronous motor is started on low-torque squirrel-cage windings prior to excitation of the field windings at the pull-in speed. The low starting torque, the torque required at pull-in, and possible voltage drop, which will lower the motor torque (varies as the square of the voltage), must all be taken into consideration when selecting a synchronous motor to start a high-specific-speed pump against a closed valve.

If a high-specific-speed pump is to be started against a closed discharge valve, high starting torques can also be avoided by the use of a bypass valve (see Section 8.2) or by an adjustable-blade pump.<sup>1</sup>



**FIGURE 21** Variation of torque during start-up of a high-specific-speed pump with a closed valve, an open valve, and a check valve. See Figure 20 for pump characteristics.

**Starting Against a Check Valve** A check valve can be used to prevent reverse flow from static head or head from other pumps in the system. The check valve will open automatically when the head from the pump exceeds system head. When a centrifugal pump is started against a check valve, pump head and torque follow shutoff values until a speed is reached at which shutoff head exceeds system head. As the valve opens, the pump head continues to increase, and, at any flow, the head will be that necessary to overcome system static head or head from other pumps, frictional head, valve head loss, and the inertia of the liquid being pumped.

Figure 19, curve *ABD*, illustrates speed-torque variation when a low-specific-speed pump is started against a check valve with static head and system friction as shown in Figure 18. Figure 21, curve *ABD*, illustrates speed-torque variation for a high-specific-speed pump started against a check valve with static head and system friction as shown in Figure 20. The use of a quick-opening check valve with high-specific-speed pumps eliminates starting against higher than full-open valve shutoff heads and torques.

The speed-torque curves shown for the period during the acceleration of the liquid in the system have been drawn with the assumption that the head required to accelerate the liquid and overcome inertia is insignificant. Acceleration head is discussed in more detail later.

**Starting Against an Open Valve** If a centrifugal pump is to take suction from a reservoir and discharge to another reservoir having the same liquid elevation or the same equivalent total pressure, it can be started without a shutoff discharge valve or check valve. The system-head curve is essentially all frictional plus the head required to accelerate the liquid in the system during the starting period. Neglecting liquid inertia, the pump head would not be greater than normal at any speed during the starting period, as shown in curve *AFGHI* of Figure 17. Pump torque would not be greater than normal at any speed during the starting period, as shown in Figures 19 and 21, curves *AD*. Pump head and torque at any speed are equal to their values at normal condition times the square of the ratio of the speed to full speed, whereas the capacity varies directly with this ratio.

**Starting a Pump Running in Reverse** When a centrifugal pump discharges against a static head or into a common discharge header with other pumps and is then stopped, the flow will reverse through the pump unless the discharge valve is closed or unless there is a check valve in the system or a broken siphon in a siphon system. If the pump does not have a nonreversing device, it will turn in the reverse direction. A pump that discharges against a static head through a siphon system without a valve will have reverse flow and speed when the siphon is being primed prior to starting.

Figures 22 and 23 illustrate typical reverse-speed-torque characteristics for a low- and a high-specific-speed pump. When flow reverses through a pump and the driver offers very

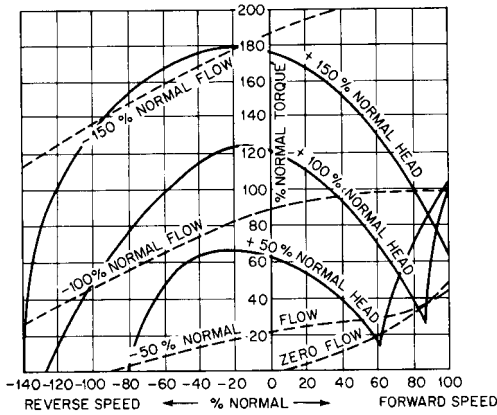


FIGURE 22 Typical reverse-speed-torque characteristics of a low-specific-speed, radial-flow, double-suction pump

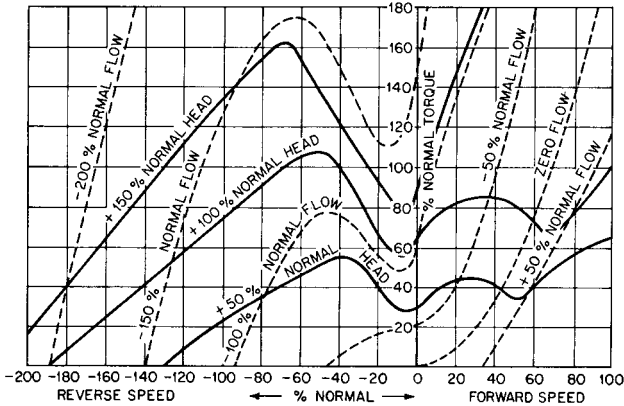


FIGURE 23 Typical reverse-speed-torque characteristics of a high-specific-speed, axial-flow, diffuser pump

little or no torque resistance, the pump will reach higher than normal forward speed in the reverse direction. This runaway speed will increase with specific speed and system head. Shown in Figures 22 and 23 are speed, torque, head, and flow, all expressed as a percentage of the pump design conditions for the normal forward speed. When a pump is running in reverse as a turbine under no load, the head on the pump will be static head (or head from other pumps) minus head loss as a result of friction due to the reverse flow.

If an attempt is made to start the pump while it is running in reverse, an electric motor must apply positive torque to the pump while the motor is initially running in a negative direction. Figures 22 and 23 show, for the two pumps, the torques required to decelerate, momentarily stop, and then accelerate the pump to normal speed. If either of these pumps were pumping into an all-static-head system, starting it in reverse would require overcoming 100% normal head, and it can be seen that a torque in excess of normal would be required by the driver while the driver is running in reverse. In addition to overcoming positive head, the driver must add additional torque to the pump to change the direction of the liquid. This could result in a prolonged starting time under higher than normal current demand. Characteristics of the motor, pump, and system must be analyzed together

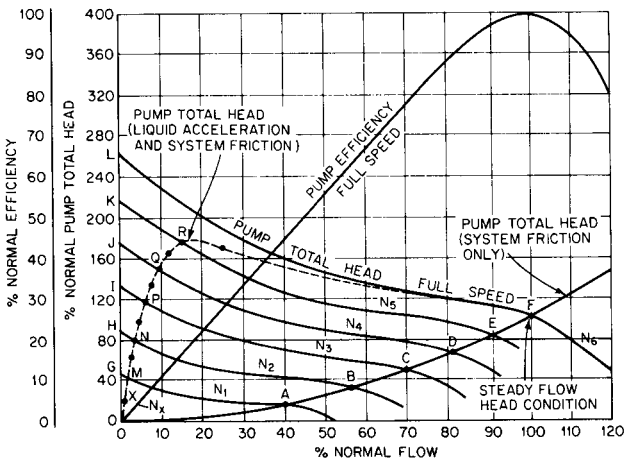


to determine actual operating conditions during this transient period. Starting torques requiring running in reverse become less severe when the system head is partly or all friction head.

**Inertial Head** If the system contains an appreciable amount of liquid, the inertia of the liquid mass could offer a significant resistance to any sudden change in velocity. Upon starting a primed pump and system without a valve, all the liquid in the system must accelerate from rest to a final condition of steady flow. Figure 24 illustrates a typical system head resistance that could be produced by a propeller pump pumping through a friction system when accelerated from rest to full speed. If the pump were accelerated very slowly, it would produce an all-friction resistance with zero liquid acceleration varying with flow approaching curve *OABCDEF*. Individual points on this curve represent system resistance at various constant pump speeds. If the pump were accelerated very rapidly, it would produce a system resistance approaching curve *OGHIJKL*. This is a shutoff condition that cannot be realized unless infinite driver torque is available. Individual points on this curve represent a system resistance at various constant speeds with no flow, which is the same as operating with a closed discharge valve. Curve *LF* represents the maximum total head the pump can produce as a result of both system friction and inertia at 100% speed. Head variation from *L* to *F* is a result of flow through the system, increasing at a decreasing rate of acceleration and increasing friction to the normal operating point *F*, where all the head is frictional. The actual total system-head resistance curve for any flow condition will be, therefore, the sum of the frictional resistance in feet (meters) for that steady-flow rate plus the inertial resistance, also expressed in feet (meters). The inertial resistance at any flow is dependent on the mass of liquid and the instantaneous rate of change of velocity at the flow condition. A typical total system resistance for a motor-driven propeller pump is shown as *OMNPQRF* in Figure 24. For a particular pump and system, different driver-speed-torque characteristics will result in a family of curves in the area *OLF*.

The added inertial system head produced momentarily when high-specific-speed pumps are started is important when considering the duration of high driver torques and currents, the pressure rise in the system, and the effect on the pump of operation at high heads and low flows. The approximate acceleration head  $h_a$  required to change the velocity of a mass of liquid at a uniform rate and cross section is

$$h_a = \frac{L \Delta V}{g \Delta t} \quad (10)$$



**FIGURE 24** Transient system head as a result of liquid acceleration and system friction when a propeller pump is started with an open valve

where  $L$  = length of constant-cross-section conduit, ft (m)

$\Delta V$  = velocity change, ft/s (m/s)

$g$  = acceleration of gravity, 32.17 ft/s<sup>2</sup> (9.807 m/s<sup>2</sup>)

$\Delta t$  = time interval, s

To calculate the time to accelerate a centrifugal pump from rest or from some initial speed to a final speed, and to estimate the pump head variation during this interim, a trial-and-error solution may be used. Divide the speed change into several increments of equal no-flow heads, such as *OGHIKL* in Figure 24. For the first incremental speed change, point *O* to point  $N_1$ , estimate the total system head, point *M*, between *G* and *A*. Next estimate the total system head, point *X*, at the average speed for this first incremental speed change. These points are shown in Figure 24. Calculate the time in seconds for this incremental speed change to take place using the equation

$$\text{in USCS units} \quad \Delta t = \frac{\Sigma WK^2 \Delta N}{307(T_D - T_P)} \quad (11a)$$

where  $\Sigma WK^2$  = total pump and motor rotor weight moment of inertia,  $W$  = weight (force),  $K$  = radius of gyration, lb · ft<sup>2</sup>

$\Delta N$  = incremental speed change, rpm

$T_D$  = motor torque at average speed, ft · lb

$T_P$  = pump torque at average speed, ft · lb

$$\text{in SI units} \quad \Delta t = \frac{\Sigma MK^2 \Delta N}{9.55(T_D - T_P)} \quad (11b)$$

where  $\Sigma MK^2$  = total pump and motor rotor mass moment of inertia,  $M$  = weight (mass),  $K$  = radius of gyration, kg · m<sup>2</sup>

$\Delta N$  = incremental speed change, rpm

$T_D$  = motor torque at average speed, N · m

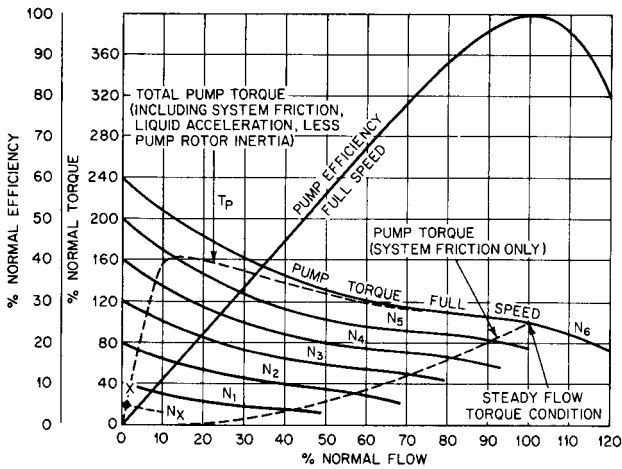
$T_P$  = pump torque at average speed, N · m

In SI units, when diameter of gyration  $D$  is used rather than radius of gyration  $K$ , and  $MD^2 = 4MK^2$ , then

$$\Delta t = \frac{\Sigma MD^2 \Delta N}{38.2(T_D - T_P)} \quad (11c)$$

Calculate the acceleration head required to change the flow in the system from point *O* to point *M* using Eq. 10 and time from Eq. 11. Add acceleration head to frictional head at the assumed average flow, and if this value is correct, it will fall on the average pump head-capacity curve, point *X*. Adjust points *M* and *X* until these assumed flows result in the total acceleration and frictional heads agreeing with flow *X* at the average speed. Repeat this procedure for other increments of speed change, adding incremental times to get total accelerating time to bring the pump up to its final speed. Plot system head versus average flow for each incremental speed change during this transient period, as shown in Figure 24.

Figures 25 and 26 illustrate how driver and pump torques can be determined from their respective speed-torque curves. Figure 25 is a family of curves that represents the torques required to produce flow against different heads without acceleration of the liquid or pump for the various speeds selected. Pump torque for any reduced speed can be calculated from the full-speed curve using the relation that torque varies as the second power and flow varies as the first power of the speed ratio. Point *X* is the torque at the average speed and the trial average flow during the first incremental speed change,



**FIGURE 25** Transient total pump torque as a result of liquid acceleration and system friction when a propeller pump is started with an open valve. Pump head characteristics are shown in Figure 24.

which is adjusted for different assumed conditions. Figure 26 shows a typical squirrel-cage induction motor speed-torque curve, and, for the purpose of illustration, it has been selected to have the same torque rating as the pump requires at full speed (approximately 97% synchronous speed). Point *X* in this figure is the motor torque at the average speed during the first incremental speed change. In Figure 26, the developed torque curve for the different speeds shown in Figure 25 is redrawn as the total frictional and inertial pump torque  $T_p$ . For the conditions used in this example, and as shown in Figure 26, after approximately 88% synchronous speed, very little excess torque ( $T_d - T_p$ ) is available for accelerating the pump and motor rotor inertia. However, as long as an induction motor has adequate torque to drive the pump at the normal condition, full speed will be reached providing the time-current demand can be tolerated. A synchronous motor, on the other hand, may not have sufficient torque to pull into step. Liquid acceleration decreases as motor torque decreases, adjusting to the available excess motor torque. The pump speed changes very slowly during the final period. Figure 26 also shows the motor current for the different speeds and torques.

A motor having a higher than normal pump torque rating or a motor having high starting torque characteristics will reduce the starting time, but higher heads will be produced during the acceleration period. Note, however, that heads produced cannot exceed shutoff at any speed. The total torque input to the pump shaft is equal to the sum of the torques required to overcome system friction, liquid inertia, and pump rotor inertia during acceleration. Torque at the pump shaft will therefore follow the motor speed-torque curve less the torque required to overcome the motor's rotor inertia. To reduce the starting inertial pump head to an acceptable amount, if desired, other alternative starting schemes can be used. A short bypass line from the pump discharge back to the suction can be provided to divert flow from the main system. The bypass valve is closed slowly after the motor reaches full speed. A variable-speed or a two-speed motor will reduce the inertial head by controlling motor torque and speed, thereby increasing the accelerating time.

This procedure for developing the actual system head and pump torque, including liquid inertia, becomes more complex if the pump must employ a discharge valve. To avoid high pump starting heads and torques, the discharge valve must be partially open on starting and then opened a sufficient amount before full speed is reached. The valve resistance must be added to the system friction and inertia curves if an exact solution is required.

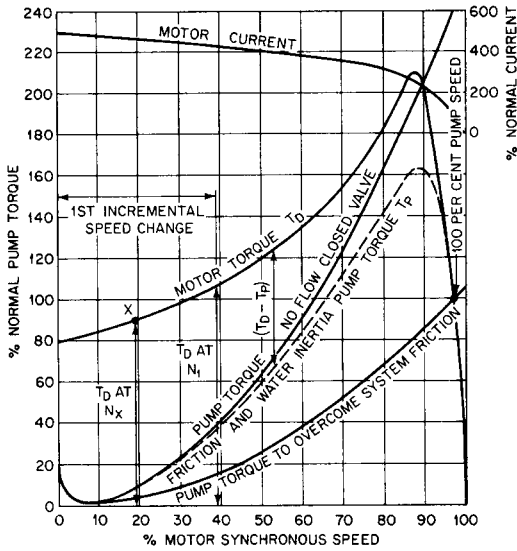


FIGURE 26 Propeller pump and motor speed-torque curves, showing effect of accelerating the liquid in the system during the starting period

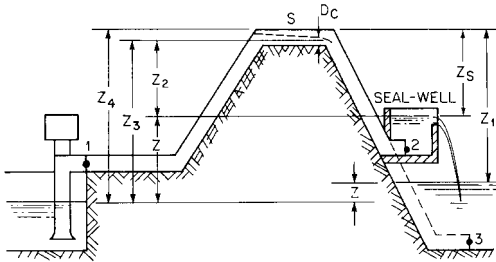


FIGURE 27 Pumping system using a siphon for head recovery

**Siphon Head** Between any two points having the same elevation in a pumping system, no head is lost because of piping elevation changes because the net change in elevation is zero. If the net change in elevation between two points is not zero, additional pump head is required if there is an increase in elevation and less head is required if there is a decrease in elevation.

When piping is laid over and under obstacles with no net change in elevation, no pumping head is required to sustain flow other than that needed to overcome frictional and minor losses. As the piping rises, the liquid pressure head is transformed to elevation head, and the reverse takes place as the piping falls. A pipe or other closed conduit that rises and falls is called a *siphon*, and one that falls and rises is called an *inverted siphon*. The siphon principle is valid provided the conduit flows full and free of liquid vapor and air so the densities of the liquid columns are alike. It is this requirement that determines the limiting height of a siphon for complete recovery because the liquid can vaporize under certain conditions.

Pressure in a siphon is minimum at the summit, or just downstream from it, and Bernoulli's equation can be used to determine if the liquid pressure is above or below vapor pressure. Referring to Figure 27, observe the following. The absolute pressure head  $H_s$  in feet (meters) at the top of the siphon is

$$H_S = H_B - Z_S + h_{f(S-2)} - \frac{V_S^2}{2g} \quad (12)$$

where  $H_B$  = barometric pressure head of liquid pumped, ft (m)

$Z_S$  = siphon height to top of conduit (=  $Z_1$  if no seal well is used), ft (m)

$h_{f(S-2)}$  = frictional and minor losses from  $S$  to 2 (or 3 if no seal well is used), including exit velocity head loss at 2 (or 3), ft (m)

$V_S^2/2g$  = velocity head at summit, ft (m)

The absolute pressure head at the summit can also be calculated using conditions in the up leg by adding the barometric pressure head to the pump head ( $TH$ ) and deducting the distance from suction level to the top of the conduit ( $Z_4$ ), the frictional loss in the up leg ( $h_{f(1-S)}$ ), and the velocity head at the summit. If the suction level is higher than the discharge level and flow is by gravity, the absolute pressure head at the summit is found as above and  $TH = 0$ .

Whenever  $Z_1$  in Figure 27 is so high that it exceeds the maximum siphon capability, a seal well is necessary to increase the pressure at the top of the siphon above vapor pressure. Note  $Z_1 - Z_S$  represents an unrecoverable head and increases the pumping head. Water has a vapor pressure of 0.77 ft (23.5 cm) at 68°F (20°C) and theoretically a 33.23-ft-high (10.13-m) siphon is possible with a 34-ft (10.36-m) water barometer. In practice, higher water temperatures and lower barometric pressures limit the height of siphons used in condenser cooling water systems to 26 to 28 ft (8 to 8.5 m). The siphon height can be found by using Eq. 12 and letting  $H_S$  equal the vapor pressure in feet (meters).

In addition to recovering head in systems such as condenser cooling water, thermal dilution, and levees, siphons are also used to prevent reverse flow after pumping is stopped by use of an automatic vacuum breaker located in the summit. Often siphons are used solely to eliminate the need for valves or flap gates.

In open-ended pumping systems, siphons can be primed by external means of air removal. Unless the siphon is primed initially upon starting, a pump must fill the system and provide a minimum flow to induce siphon action. During this filling period and until the siphon is primed, the siphon head curve must include this additional siphon filling head, which must be provided by the pump. Pumps in siphon systems are usually low-head, and they may not be capable of filling the system to the top of the siphon or of filling it with adequate flow. Low-head pumps are high-specific-speed and require more power at reduced flows than during normal pumping. Figure 28 illustrates the performance of a typical propeller pump when priming a siphon system and during normal operation.

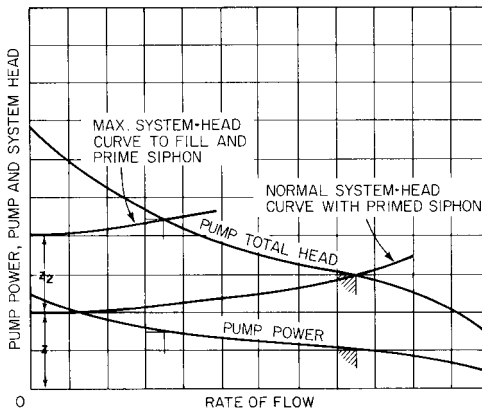


FIGURE 28 Transient system total head priming a siphon

When a pump and driver are to be selected to prime a siphon system, it is necessary to estimate the pump head and the power required to produce the minimum flow needed to start the siphon.

The minimum flow required increases with the length and the diameter and decreases with the slope of the down-leg pipe.<sup>2</sup> Prior to the removal of all the air in the system, the pump is required to provide head to raise the liquid up to and over the siphon crest. Head above the crest is required to produce a minimum flow similar to flow over a broad-crested weir. This weir head may be an appreciable part of the total pump head if the pump is low-head and large-capacity. A conservative estimate of the pump head would include a full conduit above the siphon crest. In reality, the down leg must flow partially empty before it can flow full, and it is accurate enough to estimate that the depth of liquid above the siphon crest is at critical depth for the cross section. Table 1 can be used to estimate critical depth in circular pipes, and Figure 29 can be used to calculate the cross-sectional area of the filled pipe to determine the velocity at the siphon crest.

Until all the air is removed and all the piping becomes filled, the down leg is not part of the pumping system, and its frictional and minor losses are not to be added to the maximum system-head curve to fill and prime the siphon shown in Figure 28. The total head  $TH$  in feet (meters) to be produced by the pump in Figure 27 until the siphon is primed is

$$TH = Z_3 + h_{f(1-s)} + \frac{V_c^2}{2g} \quad (13)$$

where  $Z_3$  = distance between suction level and centerline liquid at siphon crest, ft (m)

$h_{f(1-s)}$  = frictional and minor losses from 1 to  $S$ , ft (m)

$V_c^2/2g$  = velocity head at crest using actual liquid depth, approx. critical depth, ft (m)

Use of Eq. 13 permits plotting the maximum system-head curve to fill and prime the siphon for different flow rates. The pump priming flow is the intersection of the pump total head curve and this system-head curve. The pump selected must have a driver with power as shown in Figure 28 to prime the system during this transient condition.

For the pumping system shown in Figure 27, after the system is primed, the pump total head reduces to

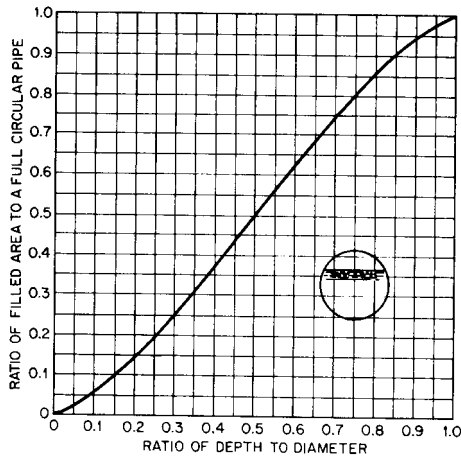
$$TH = Z + h_{f(1-2)} \quad (14)$$

**TABLE 1** Values for determining pipe-diameter ratio versus  $(ft^3/s)/d^{5/2}$  in circular pipes

$\frac{D_{crit}}{d}$	0.00	0.01	0.02	0.03	0.04	0.05	0.06	0.07	0.08	0.09
0.0	...	0.0006	0.0025	0.0055	0.0098	0.0153	0.0220	0.0298	0.0389	0.0491
0.1	0.0605	0.0731	0.0868	0.1016	0.1176	0.1347	0.1530	0.1724	0.1928	0.2144
0.2	0.2371	0.2609	0.2857	0.3116	0.3386	0.3666	0.3957	0.4259	0.4571	0.4893
0.3	0.523	0.557	0.592	0.628	0.666	0.704	0.743	0.784	0.825	0.867
0.4	0.910	0.955	1.000	1.046	1.093	1.141	1.190	1.240	1.291	1.343
0.5	1.396	1.449	1.504	1.560	1.616	1.674	1.733	1.792	1.853	1.915
0.6	1.977	2.041	2.106	2.172	2.239	2.307	2.376	2.446	2.518	2.591
0.7	2.666	2.741	2.819	2.898	2.978	3.061	3.145	3.231	3.320	3.411
0.8	3.505	3.602	3.702	3.806	3.914	4.023	4.147	4.272	4.406	4.549
0.9	4.70	4.87	5.06	5.27	5.52	5.81	6.18	6.67	7.41	8.83

All tabulated values are in units of  $(ft^3/s)/d^{5/2}$ ;  $d$  = diameter, ft;  $D_{crit}$  = critical depth, ft. For SI units, multiply  $(m^3/h)/m^{5/2}$  by  $5.03 \times 10^{-4}$  to obtain  $(ft^3/s)/ft^{5/2}$ . Examples 2, 3, and 4 illustrate the use of this table.

Source: Reference 13.



**FIGURE 29** Area versus depth for a circular pipe

In SI units:  $R = \frac{\rho VD}{\mu}$  ( $\rho$  in  $\text{kg/m}^3$ ,  $V$  in  $\text{m/s}$ ,  $D$  in  $\text{m}$ ,  $\mu$  in  $\text{N}\cdot\text{s/m}^2$ )

1 meter = 3.28 feet

1  $VD$  ( $V$  in  $\text{m/s}$ ,  $D$  in  $\text{m}$ ) = 129.2  $VD''$  ( $V$  in  $\text{ft/s}$ ,  $D''$  in inches)

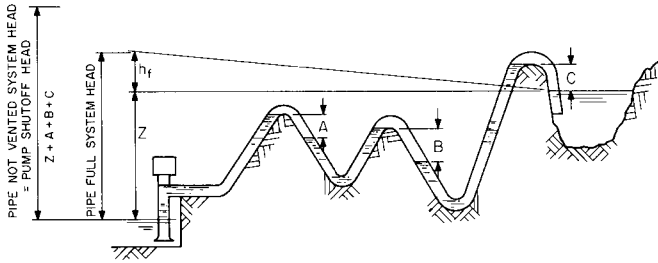
where  $Z$  = distance between suction and seal well levels (or discharge pool level if no seal well is used), ft (m)

$h_{f(1-2)}$  = frictional and minor losses from 1 to 2 (or 3 if no seal well is used), including exit velocity head loss at 2 (or 3), ft (m)

Use of Eq. 14 permits plotting of the normal system-head curve with a primed siphon, shown in Figure 28, for different flow rates. The normal pump flow is the intersection of the pump total head curve and the normal system-head curve.

If the pump cannot provide sufficient flow to prime the siphon, or if the driver does not have adequate power, the system must be primed externally by a vacuum or jet pump. An auxiliary priming pump can also be used to continuously vent the system because it is necessary that this be done to maintain full siphon recovery. In some systems, the water pumped is saturated with air, and as the liquid flows through the system, the pressure is reduced (and in cooling systems the temperature is increased). Both these conditions cause the release of some of the entrained air. Air will accumulate at the top of the siphon and in the upper parts of the down leg. The siphon works on the principle that an increase in elevation in the up leg produces a decrease in pressure and an equal decrease in elevation in the down leg resulting in recovery of this pressure. This cannot occur if the density of the liquid in the down leg is decreased as a result of the formation of air pockets. These air pockets also restrict the flow area. A release of entrained air and air leakage into the system through pipe joints and fittings will result in a centrifugal pump's delivering less than design flow, as the head will be higher than estimated. Also, high-specific-speed pumps with rising power curves toward shutoff can become overloaded. In order to maintain full head recovery, it is necessary to continuously vent the siphon at the top and at several points along the down leg, especially at the beginning of a change in slope.<sup>3</sup> These venting points can be manifolded together and connected to a single downward venting system.

Some piping systems may contain several up and down legs; that is, several siphons in series. Each down leg, as in a single siphon, is vulnerable to air or vapor binding. The likelihood of flow reduction, and conceivably in some cases complete flow shutoff, is increased in a multiple siphon system.<sup>3</sup> As shown in Figure 30, system static head is increased if



**FIGURE 30** Multiple siphon system ( $Z$  = normal system static head when pipe is flowing full). Pump flow is stopped when normal static head plus sum of air pocket heights equals pump shutoff head.

proper venting is not provided at the top of each siphon. Normally the static head is the difference between outlet and inlet elevations. If air pockets exist, head cannot be recovered and the normal static head is increased by the sum of the heights of all the intermediate liquidless pockets. Flow will stop when the total static head equals the pump shutoff head.

The following examples illustrate the use of Eqs. 3, 9, 12, 13, and 14, Table 1, and Figure 29.

**EXAMPLE 2** A pump is required to produce a flow of 70,000 gpm (15,900 m<sup>3</sup>/h) through the system shown in Figure 27. Calculate the system total head from point 1 to point 3 (no seal well) under the following conditions:

Specific gravity = 0.998 for 80°F (26.7°C) water

Barometric pressure = 29 in (73.7 cm) mercury abs (sp. gr. 13.6)

Suction and discharge water levels are equal,  $Z = 0$

$Z_1 = 40$  ft (12.2 m)

$H_{f(1-3)} = 3$  ft (0.91 m) up-leg frictional head

$h_{f(S-3)} = 3.3$  ft (1 m) down-leg frictional head, including exit loss

Pipe diameter = 48 in (121.9 cm) ID

Water vapor pressure = 0.507 lb/in<sup>2</sup> (3.5 kPa) abs at 80°F (26.7°C)

The maximum siphon height may be found from Eq. 12:

$$Z_s = H_B + h_{f(S-3)} - H_S + \frac{V_S^2}{2g}$$

From Eq. 3

$H_B$  = barometric pressure head in feet (meters) of liquid pumped

In USCS units  $\frac{\text{sp. gr.}_1}{\text{sp. gr.}_2} h_1 = \frac{13.6}{0.998} \times \frac{29}{12} = 32.9$  ft abs

$$H_S = \frac{p}{\gamma} = \frac{144 \times 0.507}{62.19} = 1.17$$
 ft abs

In SI units  $\frac{\text{sp. gr.}_1}{\text{sp. gr.}_2} h_1 = \frac{13.6}{0.998} \times \frac{73.7}{100} = 10$  m abs

$$H_S = \frac{p}{\gamma} = \frac{3.5 \times 1000}{9769} = 0.358$$
 m abs



From Eqs. 9 and 12,

$$\text{in USCS units } V_s = \frac{\text{gpm}}{(\text{pipe ID in inches})^2} \times 0.408 = \frac{70,000}{48^2} \times 0.408 = 12.4 \text{ ft/s}$$

$$Z_s = 32.9 + 3.3 - 1.17 - \frac{12.4^2}{2 \times 32.17} = 32.63 \text{ ft}$$

$$\text{in SI units } V_s = \frac{\text{m}^3/\text{h}}{(\text{pipe ID in cm})^2} \times 3.54 = \frac{15,900}{121.9^2} \times 3.54 = 3.79 \text{ m/s}$$

$$Z_s = 10 + 1 - 0.358 - \frac{3.79^2}{2 \times 9.807} = 9.1 \text{ m}$$

Because the maximum height is exceeded ( $Z_1 > Z_s$ ), siphon recovery is not possible. The system total head is therefore found from Eq. 13:

$$TH = Z_3 + h_{f(1-s)} + \frac{V_c^2}{2g}$$

The critical depth  $D_{\text{crit}}$  is found using Table 1:

$$\text{In USCS units } \text{ft}^3/\text{s} = \frac{70,000}{7.481 \times 60} = 156$$

$$\frac{\text{ft}^3/\text{s}}{d^{5/2}} = \frac{156}{4^{5/2}} = 4.88$$

$$\frac{D_{\text{crit}}}{d} = 0.901$$

$$D_{\text{crit}} = 0.901 \times 4 = 3.6 \text{ ft}$$

$$\text{In SI units } \frac{\text{m}^3/\text{h}}{d^{5/2}} = \frac{15,900}{1.219^{5/2}} = 9695$$

Convert to USCS units (see footnote to Table 1):

$$\frac{\text{ft}^3/\text{s}}{\text{ft}^{5/2}} = 9695 \times 5.03 \times 10^{-4} = 4.88$$

$$\frac{D_{\text{crit}}}{d} = 0.901$$

$$D_{\text{crit}} = 0.901 \times 1.219 = 1.1 \text{ m}$$

To calculate the water velocity at the siphon crest, determine the area of the filled pipe. From Figure 29, ratio of filled area to area of a full pipe is 0.95 for a depth-to-diameter ratio of 0.901:

$$\text{In USCS units } V_c = \frac{\text{gpm}}{0.95(\text{ID in inches})^2} \times 0.408 = \frac{70,000}{0.95 \times 48^2} \times 0.408 = 13.0 \text{ ft/s}$$

$$Z_3 = 40 - 4 + \frac{3.6}{2} = 37.8 \text{ ft}$$

$$\text{From Eq. 13 } TH = 37.8 + 3 + \frac{13.0^2}{2 \times 32.17} = 43.43 \text{ ft}$$

$$\text{In SI units } V_c = \frac{\text{m}^3/\text{h}}{0.95(\text{ID in cm})^2} \times 3.54 = \frac{15,900}{0.95 \times 121.9^2} \times 3.54 = 3.99 \text{ m/s}$$

$$Z_3 = 12.2 - 1.219 + \frac{1.1}{2} = 11.53 \text{ m}$$

From Eq. 13  $TH = 11.53 + 0.91 + \frac{3.99^2}{2 \times 9.807} = 13.25 \text{ m}$

EXAMPLE 3 Calculate the minimum total system head using conditions in Example 2 and a seal well, as shown in Figure 27. Use 2.8 ft (0.853 m) for the frictional head loss  $h_{f(s-2)}$ .

The maximum siphon height  $Z_s$  in Example 2 was found to be 32.63 ft (9.95 m). Therefore from Eq. 14 the total system head after priming is

$$TH = Z + h_{f(1-2)}$$

In USCS units  $h_{f(1-2)} = h_{f(1-s)} + h_{f(s-2)} = 3 + 2.8 = 5.8 \text{ ft}$

$$Z = Z_1 - Z_s = 40 - 32.63 = 7.37 \text{ ft}$$

In SI units  $h_{f(1-2)} = h_{f(1-s)} + h_{f(s-2)} = 0.91 + 0.853 = 1.763 \text{ ft}$

$$Z = Z_1 - Z_s = 12.2 - 9.95 = 2.25 \text{ m}$$

Note that the seal well elevation is above discharge level. Therefore

in USCS units  $TH = 7.37 + 5.8 = 13.17 \text{ ft}$

in SI units  $TH = 2.25 + 1.763 = 4.01 \text{ m}$

EXAMPLE 4 The dimensions of the down leg in Example 3 require a minimum velocity of 5 ft/s (1.52 m/s) flowing full to purge air from the system and start the siphon. Calculate the system head the pump must overcome to prime the siphon.

In USCS units  $\text{gpm} = \frac{V(\text{pipe ID in inches})^2}{0.408} = \frac{5 \times 48^2}{0.408} = 28,200$

$$\text{ft}^3/\text{s} = 28,200 \div 449 = 62.8$$

In SI units  $\text{m}^3/\text{h} = \frac{V(\text{pipe ID in cm})^2}{3.54} = \frac{1.52 \times 121.9^2}{3.54} = 6400$

The critical depth is found from Table 1:

In USCS units  $\frac{\text{ft}^3/\text{s}}{d^{5/2}} = \frac{62.8}{4^{5/2}} = 1.97$

$$\frac{D_{\text{crit}}}{d} = 0.6$$

$$D_{\text{crit}} = 0.6 \times 4 = 2.4 \text{ ft}$$

In SI units  $\frac{\text{m}^3/\text{h}}{d^{5/2}} = \frac{6400}{1.219^{5/2}} = 3902$

Convert to USCS units (see footnote to Table 1):

$$\frac{\text{ft}^3/\text{s}}{d^{5/2}} = 3902 \times 5.03 \times 10^{-4} = 1.97$$

$$\frac{D_{\text{crit}}}{d} = 0.6$$

$$D_{\text{crit}} = 0.6 \times 1.219 = 0.73 \text{ m}$$

From Figure 29, the ratio of the filled area to the area of a full pipe is 0.625 for a depth-to-diameter ratio of 0.60:

$$\text{In USCS units} \quad V_c = \frac{5}{0.625} = 8.0 \text{ ft/s}$$

$$\text{In SI units} \quad V_c = \frac{1.52}{0.625} = 2.4 \text{ m/s}$$

$$\text{From Eq. 13} \quad TH = Z_3 + h_{f(1-S)} + \frac{V_c^2}{2g}$$

$$\text{In USCS units} \quad Z_2 = Z_S - 4 + \frac{D_{\text{crit}}}{2} = 32.63 - 4 + \frac{2.4}{2} = 29.83 \text{ ft}$$

$$Z = 7.37 \text{ ft (from Example 3)}$$

$$h_{f(1-S)} \text{ at } 28,200 \text{ gpm} = \left( \frac{28,200}{70,000} \right)^2 \times 3 = 0.49 \text{ ft}$$

$$TH = (7.37 + 29.83) + 0.49 + \frac{8^2}{2 \times 32.17} = 38.68 \text{ ft}$$

$$\text{In SI units} \quad Z_2 = Z_S - 1.219 + \frac{D_{\text{crit}}}{2} = 9.95 - 1.219 + \frac{0.73}{2} = 9.1 \text{ m}$$

$$Z = 2.25 \text{ m (from Example 3)}$$

$$h_{f(1-S)} \text{ at } 6400 \text{ m}^3/\text{h} = \left( \frac{6400}{15,900} \right)^2 \times 0.91 = 0.15 \text{ m}$$

$$TH = (2.25 + 9.1) + 0.15 + \frac{2.4^2}{2 \times 9.807} = 11.79 \text{ m}$$

If the system is not externally primed, the centrifugal pump selected must be able to deliver at least 28,000 gpm (6400 m<sup>3</sup>/h) at 38.68 ft (11.79 m) total head and must be provided with a driver having adequate power for this condition. After the system is primed, the pump must be capable of delivering at least 70,000 gpm (15,900 m<sup>3</sup>/h) at 13.17 ft (4.01 m) (see Figure 28).

## HEAD LOSSES IN SYSTEM COMPONENTS

**Pressure Pipes** Resistance to flow through a pipe is caused by viscous shear stresses in the liquid and by turbulence at the pipe walls. *Laminar* flow occurs in a pipe when the average velocity is relatively low and the energy head is lost mainly as a result of viscosity. In laminar flow, liquid particles have no motion next to the pipe walls and flow occurs as a result of the movement of particles in parallel lines with velocity increasing toward the center. The movement of concentric cylinders past each other causes viscous shear stresses, more commonly called *friction*. As flow increases, the flow pattern changes, the average velocity becomes more uniform, and there is less viscous shear. As the laminar film decreases in thickness at the pipe walls and as the flow increases, the pipe roughness becomes important because it causes turbulence. *Turbulent* flow occurs when average pipe velocity is relatively high and energy head is lost predominantly because of turbulence caused by the wall roughness. The average velocity at which the flow changes from laminar to turbulent is not definite, and there is a critical zone in which either laminar or turbulent flow can occur.

Viscosity can be visualized as follows. If the space between two planar surfaces is filled with a liquid, a force will be required to move one surface at a constant velocity relative to the other. The velocity of the liquid will vary linearly between the surfaces. The ratio of the force per unit area, called *shear stress*, to the velocity per unit distance between surfaces, called *shear* or *deformation rate*, is a measure of a liquid's *dynamic* or *absolute viscosity*.

Liquids such as water and mineral oil, which exhibit shear stresses proportional to shear rates, have a constant viscosity for a particular temperature and pressure and are called *Newtonian* or *true liquids*. In the normal pumping range, however, the viscosity of true liquids may be considered independent of pressure. For these liquids, the viscosity remains constant because the rate of deformation is directly proportional to the shearing stress. The viscosity and resistance to flow, however, increase with decreasing temperature.

Liquids such as molasses, grease, starch, paint, asphalt, and tar behave differently from Newtonian liquids. The viscosity of the former does not remain constant and their shear, or deformation, rate increases more than the stress increases. These liquids, called *thixotropic*, exhibit lower viscosity as they are agitated at a constant temperature.

Still other liquids, such as mineral slurries, show an increase in viscosity as the shear rate is increased and are called *dilatant*.

In USCS units, dynamic (absolute) viscosity is measured in pound-seconds per square foot or slugs per foot-second. In SI measure, the units are newton-seconds per square meter or pascal-seconds. Usually dynamic viscosity is measured in *poises* ( $1 \text{ P} = 0.1 \text{ Pa} \cdot \text{s}$ ) or in *centipoises* ( $1 \text{ cP} = \frac{1}{100} \text{ P}$ ):

$$1 \text{ lb} \cdot \text{s}/\text{ft}^2 = 47.8801 \text{ Pa} \cdot \text{s} = 47,880.1 \text{ cP}$$

The viscous property of a liquid is also sometimes expressed as *kinematic viscosity*. This is the dynamic viscosity divided by the mass density (specific weight/ $g$ ). In USCS units, kinematic viscosity is measured in square feet per second. In SI measure, the units are square meters per second. Usually kinematic viscosity is measured in *stokes* ( $1 \text{ St} = 0.0001 \text{ m}^2/\text{s}$ ) or in *centistokes* ( $1 \text{ cSt} = \frac{1}{100} \text{ St}$ ):

$$1 \text{ ft}^2/\text{s} = 0.0929034 \text{ m}^2/\text{s} = 92,903.4 \text{ cSt}$$

A common unit of kinematic viscosity in the United States is Saybolt seconds universal (SSU) for liquids of medium viscosity and Saybolt seconds Furol (SSF) for liquids of high viscosity. Viscosities measured in these units are determined by using an instrument that measures the length of time needed to discharge a standard volume of the sample. Water at 60°F (15.6°C) has a kinematic viscosity of approximately 31 SSU (1.0 cSt). For values of 70 cSt and above,

$$\text{cSt} = 0.216 \text{ SSU}$$

$$\text{SSU} = 10 \text{ SSF}$$

The dimensionless Reynolds number  $Re$  is used to describe the type of flow in a pipe flowing full and can be expressed as follows:

$$Re = \frac{VD}{\nu} = \frac{\rho VD}{\mu} \quad (15)$$

where  $V$  = average pipe velocity, ft/s (m/s)

$D$  = inside pipe diameter, ft (m)

$\nu$  = liquid kinematic viscosity, ft<sup>2</sup>/s (m<sup>2</sup>/s)

$\rho$  = liquid density, slugs/ft<sup>3</sup> (kg/m<sup>3</sup>)

$\mu$  = liquid dynamic (or absolute) viscosity slug/ft · s (N · s/m<sup>2</sup>)

*Note:* The dimensionless Reynolds number is the same in both USCS and SI units.

When the Reynolds number is 2000 or less, the flow is generally laminar, and when it is greater than 4000, the flow is generally turbulent. The Reynolds number for the flow of water in pipes is usually well above 4000, and therefore the flow is almost always turbulent.

The Darcy-Weisbach formula is the one most often used to calculate pipe friction. This formula recognizes that friction increases with pipe wall roughness, with wetted surface area, with velocity to a power, and with viscosity and decreases with pipe diameter to a power and with density. Specifically, the frictional head loss  $h_f$  in feet (meters) is

$$h_f = f \frac{L}{D} \frac{V^2}{2g} \quad (16)$$

where  $f$  = friction factor

$L$  = pipe length, ft (m)

$D$  = inside pipe diameter, ft (m)

$V$  = average pipe velocity, ft/s (m/s)

$g$  = acceleration of gravity, 32.17 ft/s<sup>2</sup> (9.807 m/s<sup>2</sup>)

For laminar flow, the friction factor  $f$  is equal to  $64/Re$  and is independent of pipe wall roughness. For turbulent flow,  $f$  for all incompressible fluids can be determined from the well-known Moody diagram, shown in Figure 31. To determine  $f$ , it is required that the Reynolds number and the relative pipe roughness be known. Values of relative roughness  $\epsilon/D$ , where  $\epsilon$  is a measure of pipe wall roughness height in feet (meters), can be obtained from Figure 32 for different pipe diameters and materials. Figure 32 also gives values for  $f$  for the flow of 60°F (15.6°C) water in rough pipes with complete turbulence. Values of kinematic viscosity and Reynolds numbers for a number of different liquids at various temperatures are given in Figure 33. The Reynolds numbers of 60°F (15.6°C) water for various velocities and pipe diameters may be found by using the  $VD''$  scale in Figure 31.

There are many empirical formulas for calculating pipe friction for water flowing under turbulent conditions. The most widely used is the Hazen-Williams formula:

$$\text{In USCS units} \quad V = 1.318C_r^{0.63} S^{0.54} \quad (17a)$$

$$\text{In SI units} \quad V = 0.8492C_r^{0.63} S^{0.54} \quad (17b)$$

where  $V$  = average pipe velocity, ft/s (m/s)

$C$  = friction factor for this formula, which depends on roughness only

$r$  = hydraulic radius (liquid area divided by wetted perimeter) or  $D/4$  for a full pipe, ft (m)

$S$  = hydraulic gradient or frictional head loss per unit length of pipe, ft/ft (m/m)

The effect of age on a pipe should be taken into consideration when estimating the frictional loss. A lower  $C$  value should be used, depending on the expected life of the system. Table 2 gives recommended friction factors for new and old pipes. A value of  $C$  of 150 may be used for plastic pipe. Figure 34 is a nomogram that can be used in conjunction with Table 2 for a solution to the Hazen-Williams formula.

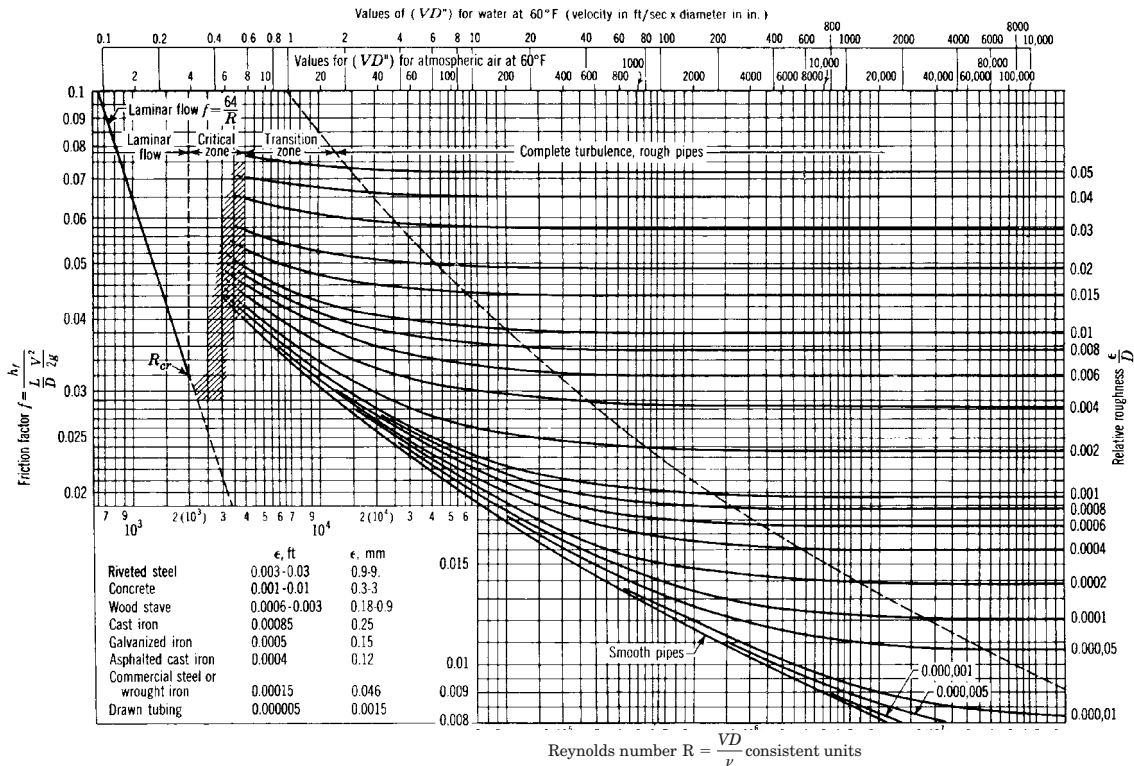
The frictional head loss in pressure pipes can be found by using either the Darcy-Weisbach formula (Eq. 16) or the Hazen-Williams formula (Eq. 17). Tables in the appendix give Darcy-Weisbach friction values for Schedule 40 new steel pipe carrying water. Tables are also provided for losses in old cast iron piping based on the Hazen-Williams formula with  $C = 100$ . In addition, values of  $C$  for various pipe materials, conditions, and years of service can also be found in the appendix.

The following examples illustrate how Figures 31, 32, and 33 and Table 2 may be used.

**EXAMPLE 5** Calculate the Reynolds number for 175°F (79.4°C) kerosene flowing through 4-in (10.16-cm), Schedule 40, 3.426-in (8.70-cm) ID, seamless steel pipe at a velocity of 14.6 ft/s (4.45 m/s).

$$\text{In USCS units} \quad VD'' = 14.6 \times 3.426 = 50 \text{ ft/s} \times \text{in}$$

$$\text{In SI units} \quad VD = 4.45 \times 0.087 = 0.387 \text{ m/s} \times \text{m} = 0.387 \times 129.2 = 50 \text{ ft/s} \times \text{in}$$



**FIGURE 31** Moody diagram. (Reference 14) In SI units:  $R = \frac{\rho VD}{\mu}$  ( $\rho$  in  $\text{kg/m}^3$ ,  $V$  in  $\text{m/s}$ ,  $D$  in  $\text{m}$ ,  $\mu$  in  $\text{N} \cdot \text{s/m}^2$ ). 1 meter = 3.28 ft;  $1VD$  ( $V$  in  $\text{m/s}$ ,  $D$  in  $\text{m}$ ) = 129.2  $VD^*$  ( $V$  in  $\text{ft/s}$ ,  $D^*$  in inches).

**TABLE 2** Values of friction factor  $C$  to be used with the Hazen-Williams formula in Figure 34

Type of pipe	Age	Size, in <sup>a</sup>	$C$
Cast iron	New	All sizes	130
		12 and over	120
	5 years old	8	119
		4	118
		24 and over	113
		12	111
	10 years old	4	107
		24 and over	100
		12	96
	20 years old	4	89
		30 and over	
		16	87
	30 years old	4	75
		30 and over	83
		16	80
40 years old	4	64	
	77		
	24	74	
40 and over	4	55	
Welded steel	Any age, any size		Same as for cast iron pipe
Riveted steel	Any age, any size		5 years old Same as cast iron pipe
			10 years older
Wood-stave	Average value, regardless of age and size		120
Concrete or concrete-lined	Large sizes, good workmanship, steel forms		140
	Large sizes, good workmanship, wooden forms		120
	Centrifugally spun		135
Vitrified	In good condition		110

<sup>a</sup>In  $\times$  25.4 = mm

Source: Adapted From Reference 15.

Follow the tracer lines in Figure 33 and read directly:

$$Re = 3.5 \times 10^5$$

**EXAMPLE 6** Calculate the frictional head loss for 100 ft (30.48 m) of 20-in (50.8-cm), Schedule 20, 19.350-in (49.15-cm) ID, seamless steel pipe for 109°F (42.8°C) water flowing at a rate of 11,500 gpm (2612 m<sup>3</sup>/h). Use the Darcy-Weisbach formula.

In USCS Units

$$V = \frac{\text{gpm}}{(\text{pipe ID in inches})^2} \times 0.408 = \frac{11,500}{19.35^2} \times 0.408 = 12.53 \text{ ft/s}$$

$$VD'' = 12.53 \times 19.35 = 242 \text{ ft/s} \times \text{in}$$

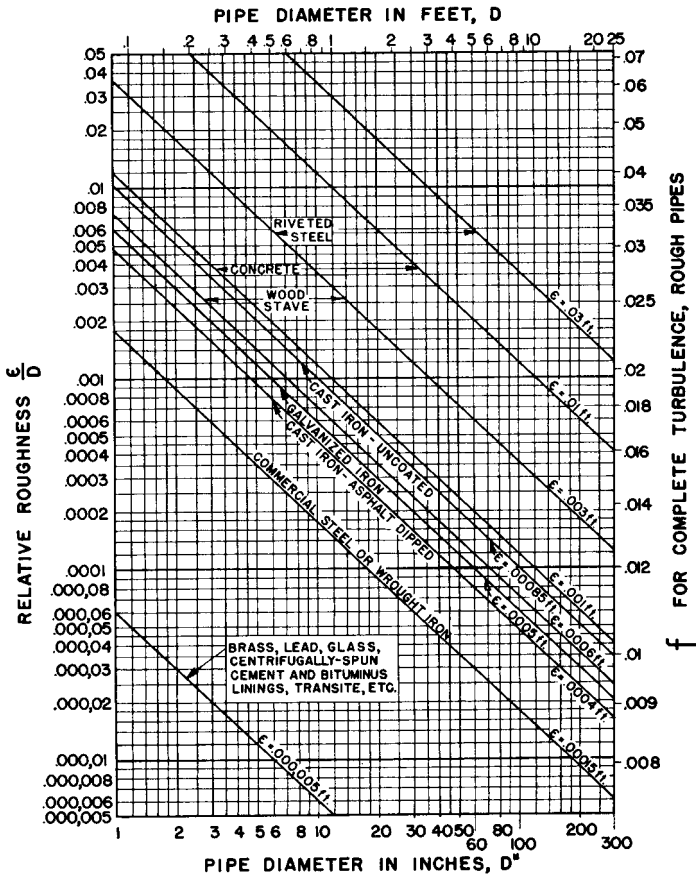


FIGURE 32 Relative roughness and friction factors for new, clean pipes for flow of 60°F (15.6°C) water (Hydraulic Institute Engineering Data Book, Reference 5) (1 meter 39.37 in = 3.28 ft).

In SI units

$$V = \frac{\text{m}^3/\text{h}}{(\text{pipe ID in cm})} \times 3.54 = \frac{2612}{49.15^2} \times 3.54 = 3.83 \text{ m/s}$$

$$VD = 3.83 \times 0.4915 = 1.88 \text{ m/s} \times \text{m} = 1.88 \times 129.2 = 242 \text{ ft/s} \times \text{in}$$

From Figure 33

$$Re = 3 \times 10^6$$

From Figure 32

$$\frac{\epsilon}{D} = 0.00009$$

From Figure 31

$$f = 0.012$$

Using Eq. 16,

In USCS units

$$D = \frac{19.35}{12} = 1.61 \text{ ft}$$



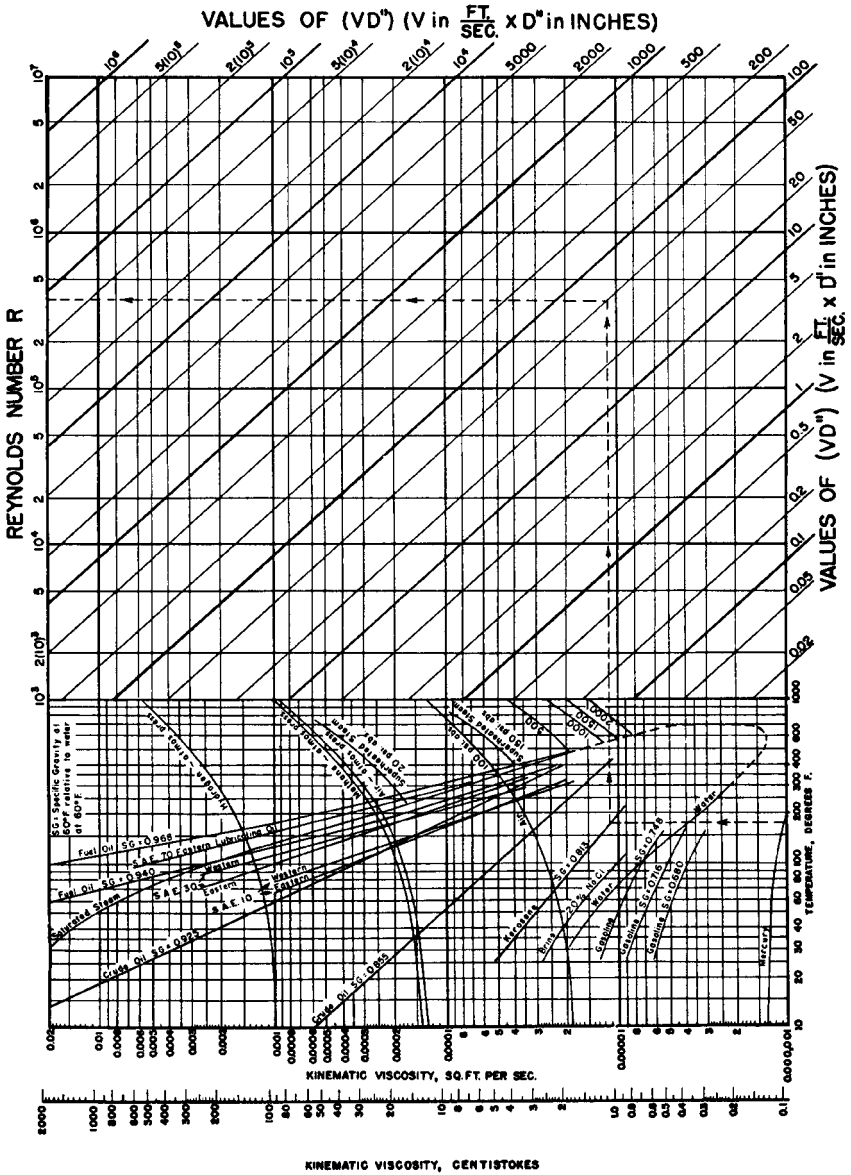


FIGURE 33 Kinematic viscosity and Reynolds number. (Hydraulic Institute Engineering Data Book, Reference 5) [1 ft<sup>2</sup>/s = 0.0929 m<sup>2</sup>/s; 1 cSt = 1.0 × 10<sup>-6</sup> m<sup>2</sup>/s; 1VD (m/s × m) = 129.2 VD" (ft/s × in); °F = (°C + 18) 1.8]

$$h_f = f \frac{L}{d} \frac{V^2}{2g} = 0.012 \frac{100}{1.61} \times \frac{12.53^2}{2 \times 32.17} = 1.82 \text{ ft}$$

$$\text{In SI units} \quad h_f = f \frac{L}{D} \frac{V^2}{2g} = 0.012 \frac{30.48}{0.4915} \times \frac{3.83^2}{2 \times 9.807} = 0.556 \text{ m}$$

EXAMPLE 7 The flow in Example 6 is increased until complete turbulence results. Determine the friction factor  $f$  and flow.

From Figure 31, follow the relative roughness curve  $\epsilon/D = 0.00009$  to the beginning of the zone marked "complete turbulence, rough pipes" and read

$$f = 0.0119 \quad \text{at } Re = 2 \times 10^7$$

The problem may also be solved using Figure 32. Enter relative roughness  $\epsilon/D = 0.00009$  and read directly across to

$$f = 0.0119$$

An increase in  $Re$  from  $3 \times 10^6$  to  $2 \times 10^7$  would require an increase in flow to

$$\text{in USCS units} \quad \frac{2 \times 10^7}{3 \times 10^6} \times 11,500 = 76,700 \text{ gpm}$$

$$\text{in SI units} \quad \frac{2 \times 10^7}{3 \times 10^6} \times 2612 = 17,413 \text{ m}^3/\text{h}$$

EXAMPLE 8 The liquid in Example 6 is changed to water at 60°F (15.6°C). Determine  $Re$ ,  $f$ , and the frictional head loss per 100 ft (100 m) of pipe.

$$VD'' = 242 \text{ ft/s} \times \text{in} \quad (\text{as in Example 6})$$

Because the liquid is 60°F (15.6°C) water, enter Figure 31 and read directly downward from  $VD''$  to

$$Re = 1.8 \times 10^6$$

Where the line  $VD''$  to  $Re$  crosses  $\epsilon/D = 0.00009$  in Figure 31, read

$$f = 0.013$$

Water at 60°F (15.6°C) is more viscous than 109°F (42.8°C) water, and this accounts for the fact that  $Re$  decreases and  $f$  increases. Using Eq. 16, it can be calculated that the frictional head loss increases to

$$\text{in USCS units} \quad h_f = f \frac{L}{D} \frac{V^2}{2g} = 0.013 \frac{100}{1.61} \times \frac{12.53^2}{2 \times 32.17} = 1.97 \text{ ft}$$

$$\text{in SI units} \quad h_f = f \frac{L}{D} \frac{V^2}{2g} = 0.013 \frac{100}{0.4915} \times \frac{3.83^2}{2 \times 9.807} = 1.97 \text{ m}$$

EXAMPLE 9 A 102-in (259-cm) ID welded steel pipe is to be used to convey water at a velocity of 11.9 ft/s (3.63 m/s). Calculate the expected loss of head due to friction per 1000 ft and per 1000 m of pipe after 20 years. Use the empirical Hazen-Williams formula.

From Table 2,  $C = 100$ .

$$\text{In USCS units} \quad r = \frac{D}{4} = \frac{102}{(4 \times 12)} = 2.13 \text{ ft}$$

$$\text{In SI units} \quad r = \frac{D}{4} = \frac{2.59}{4} = 0.648 \text{ m}$$

Substituting in Eq. 17,

in USCS units  $S^{0.54} = \frac{V}{1.318Cr^{0.63}} = \frac{11.9}{1.318 \times 100 \times 2.13^{0.63}} = 0.0557$

$S = (0.0557)^{1/0.54} = 0.0048 \text{ ft/ft}$

$h_f = 1000 \times 0.0048 = 4.8 \text{ ft}$

in SI units  $S^{0.54} = \frac{V}{0.8492Cr^{0.63}} = \frac{3.63}{0.8492 \times 100 \times 0.648^{0.63}} = 0.0562$

$S = (0.0562)^{1/0.54} = 0.0048 \text{ m/m}$

$h_f = 1000 \times 0.0048 = 4.8 \text{ m}$

The problem may also be solved by using Figure 34, following the trace lines:

$h_f \approx 5 \text{ ft (m)}$

**Frictional Loss for Viscous Liquids** Table 3 gives the frictional loss for viscous liquids flowing in new Schedule 40 steel pipe. Values of pressure loss are given for both laminar and turbulent flows.

For laminar flow, the pressure loss is directly proportional to the viscosity and the velocity of flow and inversely proportional to the pipe diameter to the fourth power. Therefore, for intermediate values of viscosity and flow, obtain the pressure loss by direct inter-

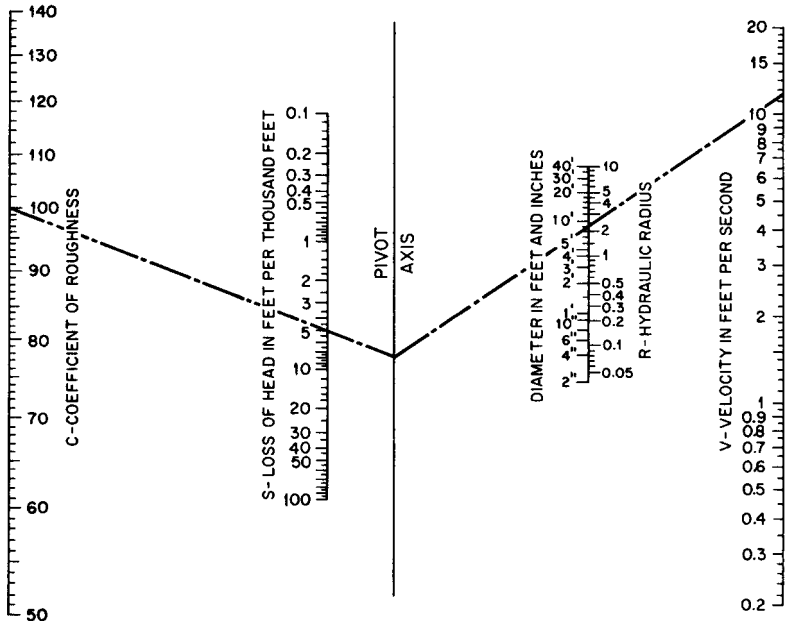


FIGURE 34 Nomogram for the solution of the the Hazen-Williams formula. Obtain values for C from Table 2. (Reference 15) (1 m/s = 3.28 ft/s; 1 m = 39.37 in)

polation. For pipe sizes not shown, multiply the fourth power of the ratio of any tabulated diameter to the pipe diameter wanted by the tabulated loss shown. The flow rate and viscosity must be the same for both diameters.

For turbulent flow and for rates of flow and pipe sizes not tabulated, the following procedures may be followed. For the viscosity and pipe size required, an intermediate flow loss is found by selecting the pressure loss for the next lower flow and multiplying by the square of the ratio of actual to tabulated flow rates. For the viscosity and flow required, an intermediate pipe diameter flow loss is found by selecting the pressure loss for the next smaller diameter and multiplying by the fifth power of the ratio of tabulated to actual inside diameters.

The viscosity of various common liquids can be found in tables in the appendix.

**Partially Full Pipes and Open Channels** Another popular empirical equation applicable to the flow of water in pipes flowing full or partially full or in open channels is the Manning formula:

$$\text{In USCS units} \quad V = \frac{1.486}{n} r^{2/3} S^{1/2} \quad (18a)$$

$$\text{In SI units} \quad V = \frac{r^{2/3} S^{1/2}}{n} \quad (18b)$$

where  $V$  = average velocity, ft/s (m/s)

$n$  = friction factor for this formula, which depends on roughness only

$r$  = hydraulic radius (liquid area divided by wetted perimeter), ft (m)

$S$  = hydraulic gradient or frictional head loss per unit length of conduit, ft/ft (m/m)

The Manning formula nomogram shown in Figure 35 can be used to determine the flow or frictional head loss in open or closed conduits. Note that the hydraulic gradient  $S$  in Figure 35 is plotted in feet per 100 ft of conduit length. Values of friction factor  $n$  are given in Table 4.

If the conduit is flowing partially full, computing the hydraulic radius is sometimes difficult. When the problem to be solved deals with a pipe that is not flowing full, Figure 36 may be used to obtain multipliers for correcting the flow and velocity of a full pipe to the values needed for the actual fill condition. If the flow in a partially full pipe is known and the frictional head loss is to be determined, Figure 36 is first used to correct the flow to what it would be if the pipe were full. Then Eq. 18 or Figure 35 is used to determine the frictional head loss (which is also the hydraulic gradient and the slope of the pipe). The problem is solved in reverse if the hydraulic gradient is known and the flow is to be determined.

For full or partially full flow in conduits that are not circular in cross section, an alternate solution to using Eq. 18 is to calculate an equivalent diameter equal to four times the hydraulic radius. If the conduit is extremely narrow and width is small relative to length (annular or elongated sections), the hydraulic radius is one-half the width of the section.<sup>4</sup> After the equivalent diameter has been determined, the problem may be solved by using the Darcy-Weisbach formula (Eq. 16).

The hydraulic gradient in a uniform open channel is synonymous with frictional head loss in a pressure pipe. The hydraulic gradient of an open channel or of a pipe flowing partially full is the slope of the free liquid surface. In the reach of the channel where the flow is uniform, the hydraulic gradient is parallel to the slope of the channel bottom. Figure 37 shows that, in a pressure pipe of uniform cross section, the slope of both the energy and hydraulic gradients is a measure of the frictional head loss per foot (meter) of pipe between points 1 and 2. Figure 38 illustrates the flow in an open channel of varying slope. Between points 1 and 2, the flow is uniform and the liquid surface (hydraulic gradient) and channel bottom are both parallel and their slope is the frictional head loss per foot (meter) of channel length.

**TABLE 3** Frictional loss for viscous liquids (Hydraulic Institute Engineering Data Book, Reference 5)

gpm	Pipe size	Viscosity, SSU							
		100	200	300	400	500	1000	1500	2000
3	$\frac{1}{2}$	11.2	23.6	35.3	47.1	59	118	177	236
	$\frac{3}{4}$	3.7	7.6	11.5	15.3	19.1	38.2	57	76
	1	1.4	2.9	4.4	5.8	7.3	14.5	21.8	29.1
5	$\frac{3}{4}$	6.1	12.7	19.1	25.5	31.9	61	96	127
	1	2.3	4.9	7.3	9.7	12.1	21.2	36.3	48.5
	$1\frac{1}{4}$	0.77	1.6	2.4	3.3	4.1	8.1	12.2	16.2
7	$\frac{3}{4}$	8.5	17.9	26.8	35.7	44.6	89	134	178
	1	3.2	6.8	10.2	13.6	17	33.9	51	68
	$1\frac{1}{4}$	1.1	2.3	3.4	4.5	5.7	11.4	17	22.7
10	1	4.9	9.7	14.5	19.4	24.2	48.5	73	97
	$1\frac{1}{4}$	1.6	3.3	4.9	6.5	8.1	16.2	24.3	32.5
	$1\frac{1}{2}$	0.84	1.8	2.6	3.5	4.4	8.8	13.1	17.5
15	1	11	14.5	21.8	29.1	36.3	73	109	145
	$1\frac{1}{4}$	2.8	4.9	7.3	9.7	12.2	24.3	36.5	48.7
	$1\frac{1}{2}$	1.3	2.6	3.9	5.3	6.6	13.1	19.7	26.3
20	1	18	18	29.1	38.8	48.5	97	145	194
	$1\frac{1}{4}$	4.9	6.4	9.7	13	16.2	32.5	48.7	65
	$1\frac{1}{2}$	2.3	3.5	5.3	7	8.8	17.5	26.3	35
	2	0.64	1.3	1.9	2.6	3.2	6.4	9.6	12.9
25	$1\frac{1}{2}$	3.5	4.4	6.6	8.8	11	21.9	32.8	43.8
	2	1	1.6	2.4	3.2	4	8	12.1	16.1
	$2\frac{1}{2}$	0.4	0.79	1.2	1.6	2	4	5.9	7.9
30	$1\frac{1}{2}$	5	5.3	7.9	10.5	13.1	26.3	39.4	53
	2	1.4	1.9	2.9	3.9	4.8	9.6	14.5	19.3
	$2\frac{1}{2}$	0.6	0.95	1.4	1.9	2.4	4.7	7.1	9.5
40	$1\frac{1}{2}$	8.5	9	10.5	14	17.5	35	53	70
	2	2.5	2.5	3.9	5.1	6.4	12.9	19.3	25.7
	$2\frac{1}{2}$	1.1	1.3	1.9	2.5	3.2	6.3	9.5	12.6
50	$1\frac{1}{2}$	12.5	14	14	17.5	21.9	43.8	66	88
	2	3.7	4	4.8	6.4	8	16.1	24.1	32.1
	$2\frac{1}{2}$	1.6	1.7	2.4	3.2	4	7.9	11.8	15.8
60	2	5	5.8	5.8	7.7	9.6	19.3	28.9	38.5
	$2\frac{1}{2}$	2.2	2.4	2.8	3.8	4.7	9.5	14.2	19
	3	0.8	0.8	1.2	1.6	2	4	6	8
70	$2\frac{1}{2}$	2.8	3.2	3.4	4.4	5.5	11.1	16.6	22.1
	3	1	1.1	1.4	1.9	2.3	4.6	7	9.3
	4	0.27	0.31	0.47	0.63	0.78	1.6	2.4	3.1
80	$2\frac{1}{2}$	3.6	4.2	4.2	5.1	6.3	12.6	19	25.3
	3	1.3	1.4	1.6	2.1	2.7	5.3	8	10.6
	4	0.36	0.36	0.54	0.72	0.89	1.8	2.7	3.6
100	$2\frac{1}{2}$	5.3	6.1	6.4	6.4	8	15.8	23.7	31.6
	3	1.9	2.2	2.2	2.7	3.3	6.6	9.9	13.3
	4	0.52	0.57	0.67	0.89	1.1	2.2	3.4	4.5

← TURBULENT FLOW → ← LAMINAR FLOW →

Loss in pounds per square inch per 100 ft of new Schedule 40 steel pipe based on specific gravity of 1.00 of that liquid. For commercial installations, it is recommended that 15% be added to the values in this table.

TABLE 3 Continued.

Viscosity, SSU									
2500	3000	4000	5000	6000	7000	8000	9000	10,000	15,000
294	353	471	589	706	824	942	...	...	...
96	115	153	191	229	268	306	344	382	573
36.3	43.6	58	73	87	101	116	131	145	218
159	191	255	319	382	446	510	573	637	956
61	73	97	121	145	170	194	218	242	363
20.3	24.3	32.5	40.6	48.7	57	65	73	81	122
223	268	357	416	535	624	713	803	892	...
85	102	136	170	203	237	271	305	339	509
28.4	34.1	45.4	57	68	80	91	102	114	170
121	145	194	242	291	339	388	436	485	727
40.6	48.7	65	81	97	114	130	146	162	243
21.9	26.3	35	43.8	53	61	70	79	88	131
182	218	291	363	436	509	581	654	727	...
61	73	97	122	146	170	195	219	243	365
32.8	39.4	53	66	79	92	105	118	131	197
242	291	388	485	581	678	775	872	...	...
81	97	130	162	195	227	260	292	325	487
43.8	53	70	88	105	123	140	158	175	263
16.1	19.3	25.7	32.1	38.5	45	51	58	64	96
55	66	88	110	131	153	176	197	219	328
20.1	24.1	32.1	40.2	48.2	56	61	72	80	121
9.9	11.8	15.8	19.7	23.7	27.6	31.6	35.5	39.5	59
66	79	105	131	158	184	210	237	263	394
24.1	28.9	38.5	48.2	58	67	77	87	96	145
11.8	14.2	19	23.7	28.4	33.2	37.9	42.6	47.4	71
88	105	140	175	210	245	280	315	350	526
32.1	38.5	51	64	77	90	103	116	129	193
15.8	19	25.3	31.6	37.9	44.2	51	57	63	95
110	131	175	219	263	307	350	394	438	657
40.2	48.2	64	80	96	112	129	145	161	241
19.7	23.7	31.6	39.5	47.4	55	63	71	79	118
48.2	58	77	96	116	135	154	173	193	289
23.7	28.4	37.9	47.4	57	66	76	85	95	142
9.9	11.9	15.9	19.9	23.9	27.9	31.8	35.8	39.8	60
27.6	33.2	44.2	55	66	77	88	100	111	166
11.6	13.9	18.6	23.2	27.8	32.5	37.1	41.7	46.4	70
3.9	4.7	6.3	7.8	9.4	11	12.5	14.1	15.6	23.5
31.6	37.9	51	63	76	88	101	114	126	190
13.3	15.9	21.2	26.5	31.8	37.1	42.4	47.7	53	80
4.5	5.4	7.2	8.9	10.7	12.5	14.3	16.1	17.9	26.8
39.5	47.4	63	79	95	111	127	142	158	237
16.6	19.9	26.5	33.1	39.8	46.4	53	60	66	99
5.6	6.7	8.9	11.2	13.4	15.6	17.9	20.1	22.3	33.5

← LAMINAR FLOW →

For a liquid having a specific gravity other than 1.00, multiply the value from the table by the specific gravity. No allowance for aging of pipe is included.

TABLE 3 Continued.

gpm	Pipe size	Viscosity, SSU							
		100	200	300	400	500	1000	1500	2000
120	3	2.7	3.1	3.2	3.2	4	8	11.9	15.9
	4	0.73	0.81	0.81	1.1	1.3	2.7	4	5.4
	6	0.98	0.11	0.16	0.21	0.26	0.52	0.78	1.0
140	3	3.4	4	4.3	4.3	4.6	9.3	13.9	18.6
	4	0.95	1.1	1.1	1.3	1.6	3.1	4.7	6.3
	6	0.17	0.18	0.21	0.28	0.35	0.69	1.0	1.4
160	3	4.4	5	5.7	5.7	5.7	10.6	15.9	21.2
	4	1.2	1.4	1.4	1.4	1.8	3.6	5.4	7.2
	6	0.17	0.18	0.21	0.28	0.35	0.69	1.0	1.4
180	3	5.3	6.3	7	7	7	11.9	17.9	23.9
	4	1.5	1.8	1.8	1.8	2	4	6	8
	6	0.2	0.24	0.24	0.31	0.39	0.78	1.2	1.6
200	3	6.5	7.7	8.8	8.8	8.8	13.3	19.9	26.5
	4	1.8	2.2	2.2	2.2	2.2	4.5	6.7	8.9
	6	0.25	0.3	0.3	0.35	0.43	0.87	1.3	1.7
250	4	2.6	3.2	3.5	3.5	3.5	5.6	8.4	11.2
	6	0.36	0.43	0.45	0.45	0.51	1.1	1.6	2.2
	8	0.95	0.12	0.12	0.15	0.18	0.36	0.54	0.72
300	4	3.7	4.3	5	5	5	6.7	10.1	13.4
	6	0.5	0.6	0.65	0.65	0.65	1.3	2	2.6
	8	0.13	0.17	0.17	0.18	0.22	0.43	0.65	0.87
400	6	0.82	1	1.1	1.2	1.2	1.7	2.6	3.5
	8	0.23	0.27	0.29	0.29	0.29	0.58	0.87	1.2
	10	0.08	0.09	0.1	0.1	0.12	0.23	0.35	0.47
500	6	1.2	1.5	1.6	1.8	1.8	2.2	3.2	4.3
	8	0.33	0.39	0.44	0.47	0.47	0.72	1.1	1.5
	10	0.11	0.14	0.15	0.15	0.15	0.29	0.44	0.58
600	6	1.8	2.2	2.3	2.4	2.6	2.7	3.9	5.2
	8	0.47	0.57	0.62	0.67	0.67	0.87	1.3	1.7
	10	0.16	0.18	0.2	0.22	0.22	0.35	0.52	0.07
700	6	2.3	2.7	3	3.2	3.5	3.6	4.6	6.1
	8	0.6	0.74	0.82	0.89	0.93	1	1.5	2
	10	0.2	0.25	0.27	0.3	0.3	0.41	0.61	0.82
800	6	2.8	3.5	3.7	4	4.2	4.8	5.2	6.9
	8	0.78	0.94	1	1.1	1.2	1.2	1.7	2.3
	10	0.26	0.3	0.34	0.38	0.4	0.47	0.7	0.92
900	6	3.5	4.3	4.6	5.0	5.2	6	6	7.8
	8	0.95	1.1	1.3	1.4	1.5	1.5	2	2.6
	10	0.32	0.37	0.43	0.46	0.5	0.52	0.79	1.1
1000	8	1.1	1.4	1.5	1.6	1.8	1.9	2.2	2.9
	10	0.38	0.45	0.5	0.55	0.6	0.6	0.87	1.2
	12	0.17	0.2	0.22	0.24	0.25	0.29	0.43	0.58

← TURBULENT FLOW → ← LAMINAR FLOW →

TABLE 3 Continued.

Viscosity, SSU									
2500	3000	4000	5000	6000	7000	8000	9000	10,000	15,000
19.9	23.9	31.8	39.8	47.7	56	61	72	80	119
6.7	8	10.7	13.4	16.1	18.8	21.4	24.1	26.8	40.2
1.3	1.6	2.1	2.6	3.1	3.6	4.2	4.7	5.2	7.8
23.2	27.8	37.1	46.4	56	65	74	84	93	139
7.8	9.4	12.5	15.6	18.8	21.9	25	28.2	31.3	46.9
1.5	1.8	2.4	3.0	3.6	4.2	4.9	5.5	6.0	9.1
26.5	31.8	42.4	53	64	74	85	95	106	159
8.9	10.7	14.3	17.9	21.5	25	28.6	32.2	35.7	54
1.7	2.1	2.8	3.5	4.2	4.9	5.5	6.2	6.9	10.4
29.8	35.8	47.7	60	72	84	95	107	119	179
10.1	12.1	16.1	20.1	24.1	28.1	32.2	36.2	40.2	60
2	2.3	3.1	3.9	4.7	5.5	6.2	7	7.8	11.7
33.1	39.8	53	66	80	93	106	119	133	199
11.2	13.4	17.9	22.3	26.8	31.3	35.7	40.2	44.7	67
2.2	2.6	3.5	4.3	5.2	6.1	6.9	7.8	8.7	13
14	16.8	22.3	27.9	33.5	39.1	44.7	50	56	84
2.7	3.3	4.3	5.4	6.5	7.6	8.7	9.8	10.8	16.3
0.9	1.1	1.5	1.8	2.2	2.5	2.9	3.3	3.6	5.4
16.8	20.1	26.8	33.5	40.2	47	54	60	67	101
3.3	3.9	5.2	6.5	7.8	9.1	10.4	11.7	13	19.5
1.0	1.3	1.7	2.2	2.6	3	3.5	3.9	4.3	6.5
4.3	5.2	6.9	8.7	10.4	12.1	13.9	15.6	17.3	26
1.5	1.7	2.3	2.9	3.5	4.1	4.6	5.2	5.8	8.7
0.58	0.7	0.93	1.2	1.4	1.6	1.9	2.1	2.3	3.5
5.4	6.5	8.7	10.8	13	15.2	17.3	19.5	21.7	32.5
1.8	2.2	2.9	3.6	4.3	5.1	5.8	6.5	7.2	10.8
0.73	0.87	1.2	1.5	1.8	2	2.3	2.6	2.9	4.4
6.5	7.8	10.4	13	16	18.2	20.8	23.4	26	39
2.2	2.6	3.5	4.3	5.2	6.1	6.9	7.8	8.7	13
0.87	1.1	1.4	1.8	2.1	2.4	2.8	3.3	3.5	5.2
7.6	9.1	12.1	15.2	18.4	21.2	24.3	27.3	30.3	45.5
2.5	3	4.1	5.1	6.1	7.1	8.1	9.1	10.1	15.2
1	1.2	1.6	2	2.4	2.9	3.3	3.7	4.1	6.1
8.7	10.4	13.9	17.3	20.8	24.3	27.7	31.2	34.7	52
2.9	3.5	4.6	5.8	6.9	8.1	9.3	10.4	11.6	17.3
1.2	1.4	1.9	2.3	2.8	3.3	3.7	4.2	4.7	7
9.8	11.7	15.6	19.5	23.4	27.3	31.2	35.1	39	58.5
3.3	3.9	5.2	6.5	7.8	9.1	10.4	11.7	13	19.5
1.3	1.6	2.1	2.6	3.1	3.7	4.2	4.7	5.2	7.9
3.6	4.3	5.8	7.2	8.7	10.1	11.6	13	14.5	21.7
1.5	1.8	2.3	2.9	3.5	4.1	4.7	5.2	5.8	8.7
0.72	0.87	1.2	1.5	1.7	2	2.3	2.6	2.9	4.3

← LAMINAR FLOW →



TABLE 3 Continued.

gpm	Pipe size	Viscosity, SSU					
		20,000	25,000	30,000	40,000	50,000	60,000
3	2	19.3	24.1	28.9	38.5	48.2	58
	2½	9.5	11.8	14.2	19	23.7	28.4
	3	4	5	6	8	9.9	11.9
5	2	32	40	48.2	64	80	96
	2½	15.8	19.7	23.7	31.6	39.5	47.4
	3	6.6	8.3	9.9	13.3	16.6	9.9
7	2	45	56	67	90	112	135
	2½	22.1	27.6	33.2	44.2	55	66
	3	9.3	10.6	13.9	18.6	23.2	27.8
10	2½	31.6	39.5	47.4	63	79	95
	3	13.3	16.6	19.9	26.5	33.1	39.8
	4	4.5	5.6	6.7	8.9	11.2	13.4
15	2½	47.4	59	71	95	118	142
	3	19.9	24.9	29.8	39.8	49.7	60
	4	6.7	8.4	10.1	13.4	16.8	20.1
20	3	26.5	33.1	39.8	53	66	80
	4	8.9	11.2	13.4	17.9	22.3	26.8
	6	1.7	2.2	2.6	3.5	4.3	5.2
25	3	33.1	41.4	49.7	66	83	99
	4	11.2	14	16.8	22.3	27.9	33.5
	6	2.2	2.7	3.3	4.3	5.4	6.5
30	3	39.8	49.7	60	80	99	119
	4	13.4	16.8	20.1	26.8	33.5	40.2
	6	2.6	3.3	3.9	5.2	6.5	7.8
40	3	53	66	80	106	133	160
	4	17.9	22.3	26.8	35.7	44.7	54
	6	3.5	4.3	5.2	6.9	8.7	10.4
50	4	22.3	27.9	33.5	44.7	56	67
	6	4.3	5.4	6.5	8.7	10.8	13
	8	1.5	1.8	2.7	2.9	3.6	4.3
60	4	26.8	33.5	40.2	54	67	80
	6	5.2	6.5	7.8	10.4	13	16
	8	1.7	2.2	2.6	3.5	4.3	5.2
70	4	31.3	39.1	46.9	63	78	94
	6	6.1	7.6	9.1	12.1	15.2	18.4
	8	2	2.5	3	4.1	5.1	6.1
80	6	6.9	8.7	10.4	13.9	17.3	20.8
	8	2.3	2.9	3.5	4.6	5.8	6.9
	10	0.93	1.2	1.4	1.9	2.3	2.8
90	6	7.8	9.8	11.7	15.6	19.5	23.4
	8	2.6	3.3	3.9	5.2	6.5	7.8
	10	1.1	1.3	1.6	2.1	2.6	3.1

← LAMINAR FLOW →

TABLE 3 Continued.

Viscosity, SSU								
70,000	80,000	90,000	100,000	125,000	150,000	175,000	200,000	500,000
67	77	87	96	120	145	169	193	482
332	37.9	42.6	47.4	59	71	83	95	237
13.9	15.9	17.9	19.9	24.9	29.8	34.8	39.8	99
112	129	145	161	200	241	281	321	803
55	63	71	79	99	118	138	158	395
23.2	26.5	29.8	33	41.4	49.7	58	66	166
157	180	202	225	281	337	393	450	...
77	88	100	111	138	166	194	221	553
32.5	37.1	40.7	46.4	58	70	81	93	232
111	126	142	158	197	237	276	316	790
46.4	53	60	66	83	99	116	133	331
15.6	17.9	20.1	22.3	27.9	33.5	39.1	44.7	112
166	190	213	237	296	355	415	474	...
70	80	89	99	124	149	174	199	497
23.5	26.8	30.2	33.5	41.9	50	59	67	168
93	106	119	133	166	199	232	265	663
31.3	35.7	40.2	44.7	56	67	78	89	223
6.1	6.9	7.8	8.7	10.8	13	15.2	17.3	43.3
116	133	149	166	207	49	290	331	828
39.1	44.7	50	56	70	84	98	112	279
7.6	8.7	9.8	10.8	13.5	16.3	19	21.7	54
139	159	179	199	249	298	348	398	...
46.9	54	60	67	84	101	117	134	335
9.1	10.4	11.7	13	16.3	19.5	22.7	26	65
186	212	239	265	331	398	464	532	...
63	72	80	89	112	134	156	179	447
12.1	13.9	15.6	17.3	21.7	26	30.3	34.7	87
78	89	101	112	140	168	196	223	559
15.2	17.3	19.5	21.7	27.1	32.5	37.9	43.3	107
5.1	5.8	6.5	7.2	9	10.8	12.6	14.5	36.1
94	107	121	134	168	201	235	268	670
18.2	20.8	23.4	26	32.5	39	45.5	52	130
6.1	6.9	7.8	8.7	10.8	13	15.2	17.3	43.4
110	125	141	156	196	235	274	313	782
21.2	24.3	27.3	30.3	37.9	45.5	53	61	152
7.1	8.1	9.1	10.1	12.6	15.2	17.7	20.2	51
24.3	27.7	31.2	34.7	43.3	52	61	69	173
8.1	9.3	10.4	11.6	14.5	17.3	20.2	23.1	58
3.3	3.7	4.2	4.7	5.8	7	8.2	9.3	23.3
27.3	31.2	35.1	39	48.7	59	68	78	195
9.1	10.4	11.7	13	16.3	19.5	22.8	26	65
3.7	4.2	4.7	5.2	6.6	7.9	9.2	10.5	26.2

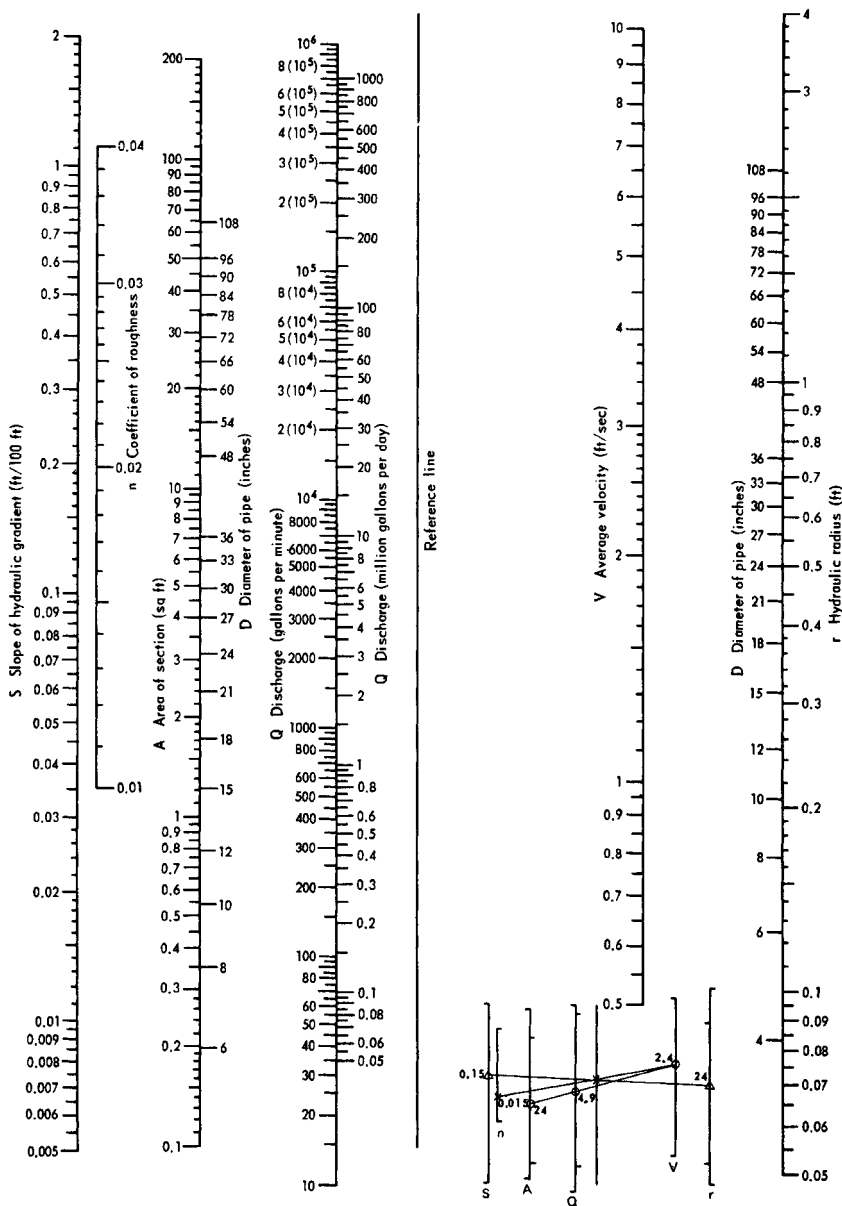
← LAMINAR FLOW →

TABLE 3 Continued.

gpm	Pipe size	Viscosity, SSU					
		20,000	25,000	30,000	40,000	50,000	60,000
100	6	8.7	10.8	13	17.3	21.7	26
	8	2.9	3.6	4.3	5.8	7.2	8.7
	10	1.2	1.5	1.8	2.3	2.9	3.5
120	6	10.4	13	15.6	20.8	26	31.2
	8	3.5	4.3	5.2	6.9	8.7	10.4
	10	1.4	1.8	2.1	2.8	3.5	4.2
140	6	12.1	15.2	18.2	24.3	30.3	36.4
	8	4	5.1	6.1	8.1	10.1	12.1
	10	1.7	2	2.4	3.3	4.1	4.9
160	6	13.9	17.3	20.8	27.7	34.7	41.6
	8	4.6	5.8	6.9	9.3	11.6	13.8
	10	1.9	2.3	2.8	3.7	4.7	5.6
180	6	15.6	19.5	23.4	31.2	39	46.8
	8	5.2	6.5	7.8	10.4	13	15.6
	10	2.1	2.6	3.1	4.2	5.2	6.3
200	8	5.8	7.2	8.7	11.6	14.5	17.3
	10	2.3	2.9	3.5	4.7	5.8	7
	12	1.2	1.5	1.7	2.3	2.9	3.5
250	8	7.2	9	10.8	14.5	18.1	21.7
	10	2.9	3.6	4.4	5.8	7.3	8.7
	12	1.5	1.8	2.2	2.9	3.6	4.3
300	8	8.7	10.8	13	17.3	21.7	26
	10	3.5	4.4	5.2	7	8.7	10.5
	12	1.7	2.2	2.6	3.5	4.3	5.2
400	8	11.6	14.5	17.3	23	28.9	34.7
	10	4.7	5.8	7	9.3	11.6	14
	12	2.3	2.9	3.5	4.6	5.8	7
500	8	14.5	18.1	21.7	28.9	36.1	43.4
	10	5.8	7.3	8.7	11.6	14.6	17.5
	12	2.9	3.6	4.3	5.8	7.2	8.7
600	8	17.3	21.7	26	34.7	43.4	52
	10	7	8.7	10.5	14	17.5	21
	12	3.5	4.3	5.2	7	8.7	10.4
700	8	20.2	25.3	30.3	40.5	51	61
	10	8.2	10.2	12.2	16.3	20.4	24.4
	12	4.1	5.1	6.1	8.1	10.1	12.2
800	8	23.1	28.9	34.7	46.2	58	69
	10	9.3	11.6	14	18.6	23.3	27.9
	12	4.6	5.8	7	9.3	11.6	13.9
900	8	26	32.5	39	52	65	78
	10	10.5	13.1	15.7	21	26.2	31.4
	12	5.2	6.5	7.8	10.4	13	15.6
1000	8	28.9	36.1	43.4	58	72	87
	10	11.6	14.6	17.5	23.3	29.1	34.9
	12	5.8	7.2	8.7	11.6	14.5	17.4

TABLE 3 Continued.

Viscosity, SSU								
70,000	80,000	90,000	100,000	125,000	150,000	175,000	200,000	500,000
30.3	34.7	39	43.3	54	65	76	87	217
10.1	11.6	13	14.5	18.1	21.7	25.3	28.9	72
4.2	4.7	5.2	5.8	7.3	8.7	10.2	11.6	29.1
36.4	41.6	46.8	52	65	78	91	104	260
12.1	13.9	15.6	17.3	21.7	26	30.4	34.7	87
4.9	5.6	6.3	7	8.7	10.5	12.2	14	34.9
42.5	48.5	55	61	76	91	106	121	303
14.2	16.2	18.2	20.2	25.3	30.4	35.4	40.5	101
5.7	6.5	7.3	8.1	10.2	12.2	14.3	16.3	40.7
48.5	56	62	69	87	104	121	139	347
16.2	18.5	20.8	23.1	28.9	34.7	40.5	46.2	116
6.5	7.5	8.4	9.3	11.6	14	16.3	18.6	46.6
55	62	70	78	98	117	137	156	390
18.2	20.8	23.4	26	32.5	39	45.5	52	130
7.3	8.4	9.4	10.5	13.1	15.7	18.3	21	52
20.2	23.1	26	28.9	36.1	43.4	51	58	145
8.2	9.3	10.5	11.6	14.6	17.5	20.4	23.3	58
4.1	4.6	5.2	5.8	7.2	8.7	10.1	11.6	28.9
25.3	28.9	32.5	36.1	45.2	54	63	72	181
10.2	11.6	13.1	14.6	18.2	21.8	25.5	29.1	73
5.1	5.8	6.5	7.2	9	10.9	12.7	14.5	36.2
30.4	34.7	39	43.4	54	65	76	87	217
12.2	14	15.7	17.5	21.8	26.2	30.6	34.9	87
6.1	7	7.8	8.7	10.9	13	15.2	17.4	43.4
40.5	46.2	52	58	72	87	101	116	289
16.3	18.6	21	23.3	29.6	34.9	40.7	46.6	116
8.1	9.3	10.4	11.6	14.5	17.4	20.3	23.2	58
51	58	65	72	90	108	126	145	361
20.4	23.3	26.2	29.1	36.4	43.7	51	58	146
10.1	11.6	13	14.5	18.1	21.7	25.3	28.9	72
61	69	78	87	107	130	152	173	434
24.4	27.9	31.4	34.9	43.7	52	61	70	175
12.2	13.9	15.6	17.4	21.7	26.1	30.4	34.7	87
71	81	91	101	126	152	177	202	506
28.5	32.6	36.7	40.7	51	61	71	82	204
14.2	16.2	18.2	20.3	25.3	30.4	35.5	40.5	101
81	93	104	116	145	173	202	231	578
32.6	37.3	41.9	46.6	58	70	82	93	233
16.2	18.5	20.8	23.1	28.9	34.7	40.5	46.3	116
91	104	117	130	163	195	228	260	650
36.7	41.9	47.1	52	66	79	92	105	262
18.2	20.8	23.4	26.1	32.6	39.1	45.6	52	130
101	116	130	145	181	217	253	289	723
40.7	46.6	52	58	72	87	102	116	291
20.3	23.2	26.1	28.9	36.2	43.4	51	58	145



**FIGURE 35** Nonogram for the solution of the Manning formula. Obtain values of  $n$  from Table 4. To solve for  $S$ , align  $A$  with  $Q$  and read  $V$ , align  $V$  and  $n$  intersecting reference line, align  $r$  with reference line intersection, and read  $S$  (1 m = 3.28 ft; 1 m = 39.37 in; 1 m<sup>2</sup> = 1550 in<sup>2</sup>; 1 m<sup>3</sup>/h = 4.4 gpm; 1 m/s = 3.28 ft/s; 1 m/m = 1 ft/ft).

**TABLE 4** Values of friction factor  $n$  to be used with the Manning Formula in Figure 35

Surface	Rest	Good	Fair	Bad
Uncoated cast iron pipe	0.012	0.013	0.014	0.015
Coated cast iron pipe	0.011	0.012 <sup>a</sup>	0.013 <sup>a</sup>	
Commercial wrought iron pipe, black	0.012	0.013	0.014	0.015
Commercial wrought iron pipe, galvanized	0.013	0.014	0.015	0.017
Smooth brass and glass pipe	0.009	0.010	0.011	0.013
Smooth lockbar and welded OD pipe	0.010	0.011 <sup>a</sup>	0.013 <sup>a</sup>	
Riveted and spiral steel pipe	0.013	0.015 <sup>a</sup>	0.017 <sup>a</sup>	
Vitrified sewer pipe	0.010	0.013 <sup>a</sup>	0.015	0.017
	0.011			
Common clay drainage tile	0.011	0.012 <sup>a</sup>	0.014 <sup>a</sup>	0.017
Glazed brickwork	0.011	0.012	0.013 <sup>a</sup>	0.015
Brick in cement mortar; brick sewers	0.012	0.013	0.015 <sup>a</sup>	0.017
Neat cement surfaces	0.010	0.011	0.012	0.013
Cement mortar surfaces	0.011	0.012	0.013 <sup>a</sup>	0.015
Concrete pipe	0.012	0.013	0.015 <sup>a</sup>	0.016
Wood-stave pipe	0.010	0.011	0.012	0.013
Plank flumes:				
Planed	0.010	0.012 <sup>a</sup>	0.013	0.014
Unplaned	0.011	0.013 <sup>a</sup>	0.014	0.015
With battens	0.012	0.015 <sup>a</sup>	0.016	
Concrete-lined channels	0.012	0.014 <sup>a</sup>	0.016 <sup>a</sup>	0.018
Cement-rubble surface	0.017	0.020	0.025	0.030
Dry-rubble surface	0.025	0.030	0.033	0.035
Dressed-ashlar surface	0.013	0.014	0.015	0.017
Semicircular metal flumes, smooth	0.011	0.012	0.013	0.015
Semicircular metal flumes, corrugated	0.0225	0.025	0.0275	0.030
Canals and ditches:				
Earth, straight and uniform	0.017	0.020	0.0225 <sup>a</sup>	0.025
Rock cuts, smooth and uniform	0.025	0.030	0.033 <sup>a</sup>	0.035
Rock cuts, jagged and irregular	0.035	0.040	0.045	
Winding sluggish canals	0.0225	0.025 <sup>a</sup>	0.0275	0.030
Dredged earth channels	0.025	0.0275 <sup>a</sup>	0.030	0.033
Canals with rough stony beds, weeds on earth banks	0.025	0.030	0.035 <sup>a</sup>	0.040
Earth bottom, rubble sides	0.028	0.030 <sup>a</sup>	0.033 <sup>a</sup>	0.035
Natural stream channels:				
(1) Clean, straight bank, full stage, no rifts or deep pools	0.025	0.0275	0.030	0.033
(2) Same as (1), but some weeds and stones	0.030	0.033	0.035	0.040
(3) Winding, some pools and shoals, clean	0.033	0.035	0.040	0.045
(4) Same as (3), lower stages, more ineffective slope and sections	0.040	0.045	0.050	0.055
(5) Same as (3), some 2, eeds and stones	0.035	0.040	0.045	0.050
(6) Same as (4), stony sections	0.045	0.050	0.055	0.060
(7) Sluggish river reaches, rather weedy or with very deep pools	0.050	0.060	0.070	0.080
(8) Very weedy reaches	0.075	0.100	0.125	0.150

<sup>a</sup>Values commonly used in designing.

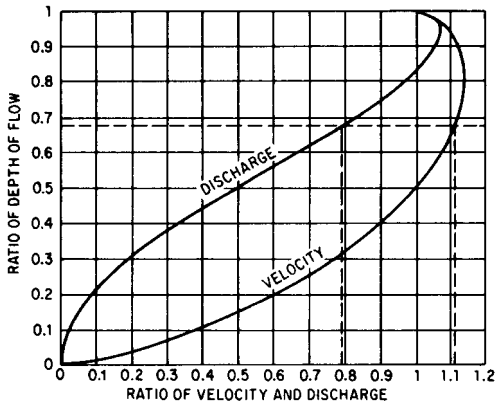


FIGURE 36 Discharge velocity of a partially full circular pipe versus that of a full pipe

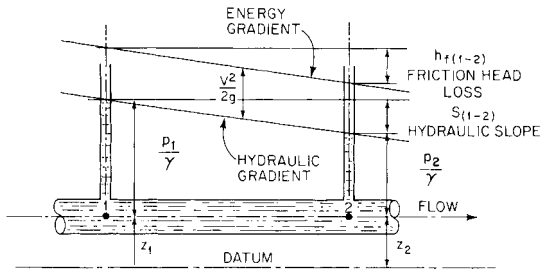


FIGURE 37 Slopes of energy and hydraulic gradients measure frictional head loss ft/ft (m/m) of pipe length

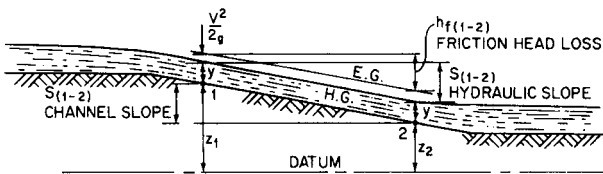


FIGURE 38 In an open channel with uniform flow, slopes of channel bottom, energy, and hydraulic gradients are the same as frictional head loss ft/ft (m/m) of channel length.

A rearrangement of Eq. 18 gives

in USCS units 
$$S = h_f = \left( \frac{Vn}{1.486r^{2/3}} \right)^2 \tag{19a}$$

in SI units 
$$S = h_f = \left( \frac{Vn}{r^{2/3}} \right)^2 \tag{19b}$$

The following examples illustrate the application of the Manning formula (Eq. 19), Figures 35 and 36, and Table 4 to the solution of problems involving the flow of water in open channels.

**EXAMPLE 10** The flow through a 24-in (61.0-cm) ID commercial wrought iron pipe in fair condition is 4.9 mgd (772.7 m<sup>3</sup>/h). Determine the loss of head as a result of friction in feet per 100 ft (meters per 100 m) of pipe and the slope required to maintain a full, uniformly flowing pipe.

$$\text{In USCS units} \quad V = \frac{\text{gpm}}{(\text{pipe ID in inches})^2} \times 0.408 = \frac{4.9 \times 10^6 \times 0.408}{24 \times 60 \times 24^2} = 2.41 \text{ ft/s}$$

$$\text{In SI units} \quad V = \frac{\text{m}^3/\text{h}}{(\text{pipe ID in cm})^2} \times 3.54 = \frac{772.7}{60.96^2} \times 3.54 = 0.736 \text{ m/s}$$

From Table 4,  $n = 0.015$ .

In USCS units

$$r = D/4 = 2/4 = 0.5 \text{ ft} \quad (\text{hydraulic radius})$$

$$S = h_f = \left( \frac{Vn}{1.486r^{2/3}} \right)^2 = \left( \frac{2.41 \times 0.015}{1.486 \times 0.5^{2/3}} \right)^2 \quad (\text{from Eq. 19a})$$

$$= 0.0015 \text{ ft/ft}$$

$$100 \times 0.0015 = 0.15 \text{ ft/100 ft} \quad (\text{slope and frictional head})$$

In SI units

$$r = D/4 = 0.6096/4 = 0.1524 \text{ m} \quad (\text{hydraulic radius})$$

$$S = h_f = \left( \frac{Vn}{r^{2/3}} \right)^2 = \left( \frac{0.736 \times 0.015}{0.1524^{2/3}} \right)^2 \quad (\text{from Eq. 19b})$$

$$= 0.0015 \text{ m/m}$$

$$100 \times 0.0015 = 0.15 \text{ m/100 m} \quad (\text{slope and frictional head})$$

The problem may also be solved by using Figure 35 and following the trace lines:

$$S = h_f = 0.15 \text{ ft/100 ft (m/100 m)}$$

**EXAMPLE 11** Determine what the flow and velocity would be if the pipe in Example 10 were flowing two-thirds full and were laid on the same slope.

Follow the trace lines in Figure 36 and note that the multipliers for discharge and velocity are 0.79 and 1.11, respectively. Therefore

$$\text{in USCS units} \quad \text{Flow} = 0.79 \times 4.9 = 3.87 \text{ mgd}$$

$$\text{Velocity} = 1.11 \times 2.41 = 2.68 \text{ ft/s}$$

$$\text{in SI units} \quad \text{Flow} = 0.79 \times 772.7 = 610 \text{ m}^3/\text{h}$$

$$\text{Velocity} = 1.11 \times 0.736 = 0.817 \text{ m/s}$$

**Pipe Fittings** Invariably, a system containing piping will have connections that change the size or direction of the conduit. These fittings add frictional losses, called *minor losses*, to the system head. Fitting losses are generally the result of changes in velocity or direction. A decreasing velocity results in more loss in head than an increasing velocity, as the former causes energy-dissipating eddies. Experimental results have



indicated that minor losses vary approximately as the square of the velocity through the fittings.

**VALVES AND STANDARD FITTINGS** The resistance to flow through valves and fittings may be found in References 4, 5, 17, and other sources. Losses are usually expressed in terms of a *resistance coefficient*  $K$  and the average velocity head in a pipe having the same diameter as the valve or fitting. The frictional resistance  $h$  in feet (meters) is found from the equation

$$h = K \frac{V^2}{2g} \quad (20)$$

where  $K$  = resistance coefficient, which depends on design and size of valve or fitting

$V$  = average velocity in pipe of corresponding internal diameter, ft/s (m/s)

$g$  = acceleration of gravity, 32.17 ft/s<sup>2</sup> (9.807 m/s<sup>2</sup>)

A comparison of the Darcy-Weisbach equation (Eq. 16) with Eq. 20 suggests that  $K$  equals  $f(L/D)$ , where  $L$  is the equivalent length of pipe in feet (meters) and  $D$  is the inside pipe diameter in feet (meters), to produce the same head loss in a straight pipe as through a valve or fitting. The friction in an “equivalent length of pipe” has been another method used to estimate head loss through valves and fittings. Values of the ratio  $L/D$  have been experimentally determined. This ratio multiplied by the inside diameter of a pipe of specified schedule for the valve or fitting being considered gives the equivalent length of pipe to use to calculate the head lost.



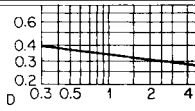


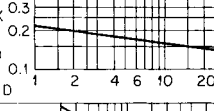


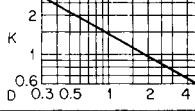

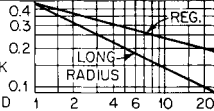


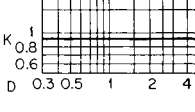


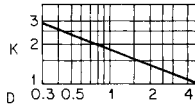


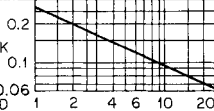


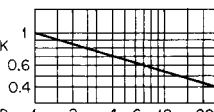
Loss of head in straight pipe depends on the friction factor or Reynolds number. However, with valves and fittings, head is lost primarily because of change in direction of flow, change in cross section, and obstructions in the flow path. For this reason, the resistance coefficient is practically constant for a particular shape of valve or fitting for all flow conditions, including laminar flow. The resistance coefficient would theoretically be constant for all sizes of a particular design of valve or fitting except that all sizes are not geometrically similar. The Crane Company has reported the results of tests that show that the resistance coefficient for a number of lines of valves and fittings decreases with increasing size at flow conditions of equal friction factor and that the equivalent length  $L/D$  tends to be constant for the various sizes at the same flow conditions.

When available, the  $K$  factor furnished by the valve or fitting manufacturer should always be used rather than the value from a general listing. The Hydraulic Institute lists losses in terms of  $K$  through valves and fittings (Tables 5a to 5c); these losses vary with size of the valve or fitting but are independent of friction factor. The Crane Company provides a similar listing of  $K$  values (Tables 6a to 6e). The latter listing of flow coefficients is associated with the velocity head  $V^2/2g$  that would occur through the internal diameter of the schedule pipes for the various ANSI classes of valves and fittings shown in Table 6e. If the connecting pipe is of a different size or schedule, either use the velocity for the pipe shown in Table 6a or use the actual pipe velocity head and correct the resistance coefficient obtained from this table by the multiplier

$$\left( \frac{\text{Actual pipe } ID}{\text{Standard pipe } ID} \right)^4$$

Tables 6 are based on the use of an equivalent length constant for complete turbulent flow for each valve or fitting shown. This constant is shown as the multiplier of the friction factor  $f_T$  for the corresponding clean commercial steel pipe with completely turbulent flow. The product  $(L/D)(f_T)$  is the coefficient  $K$ . The friction factors are given in Table 6a for different pipe sizes, or they can be obtained from Figure 31 or 32. If the valve or fitting has a sudden or gradual contraction, enlargement, or change in direction of flow, appropriate formulas for these conditions are given for the determination of  $K$ . If flow is laminar, valve and fitting resistance coefficients are obtained from Table 6a based on completely turbu-

TABLE 5A Resistance coefficients for  $K$  for valves and fittings

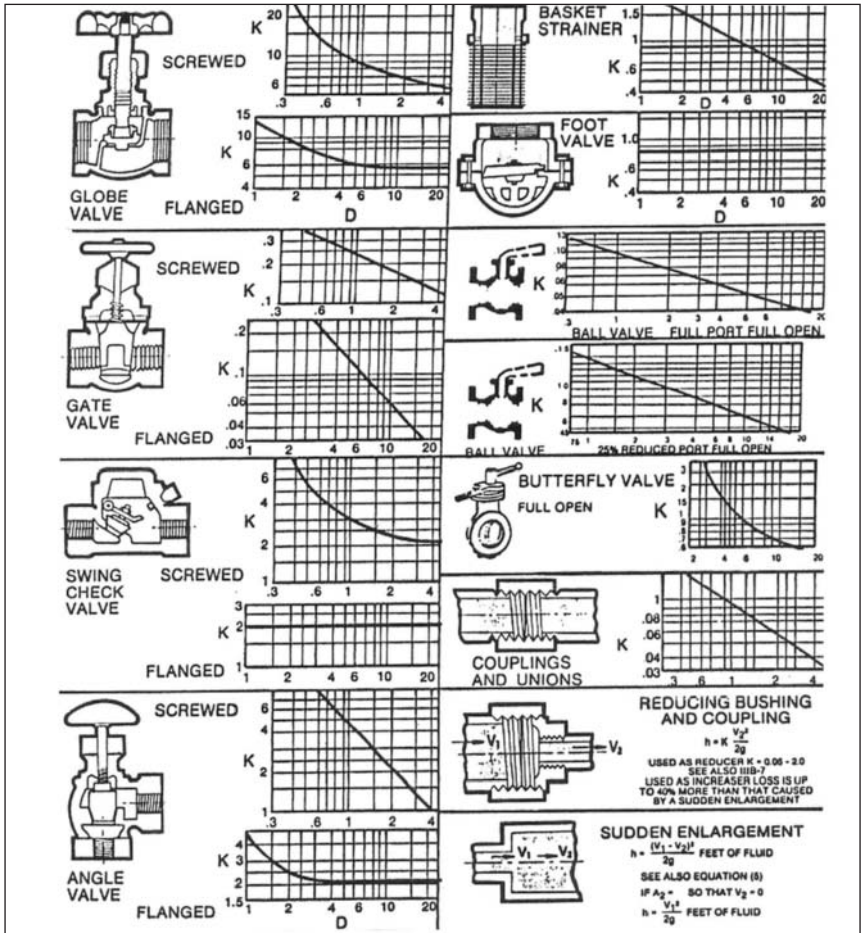
	BELL-MOUTH INLET OR REDUCER $K=0.05$		REGULAR SCREWED 45° ELL	
	SQUARE EDGED INLET $K=0.5$		LONG RADIUS FLANGED 45° ELL	
	INWARD PROJECTING PIPE $K=1.0$		SCREWED RETURN BEND	
NOTE: $K$ DECREASES WITH INCREASING WALL THICKNESS OF PIPE AND ROUNDING OF EDGES			FLANGED RETURN BEND	
	REGULAR SCREWED 90° ELL		LINE FLOW	
	LONG RADIUS SCREWED 90° ELL		SCREWED TEE	
	REGULAR FLANGED 90° ELL		LINE FLOW	
	LONG RADIUS FLANGED 90° ELL		FLANGED TEE	

$$h = K \frac{V^2}{2g} \quad \text{FEET (METERS) OF FLUID}$$

NOTE:  $D$  = nominal iron pipe size in inches ( $\text{in} \times 25.4 = \text{mm}$ ). (Hydraulic Institute Engineering Data Book, Reference 5)

lent flow, but the pipe frictional loss is calculated using the laminar friction factor  $f = 64/Re$  instead of  $f_T$ . Also shown in Tables 6 for check valves is the minimum pipe velocity required for full disk lift for the coefficient of resistance listed ( $\bar{V}$  = liquid specific volume in cubic feet per pound).

Prior to the 15th printing (1976) of the Crane Company Technical Paper 410, and as shown in the first edition of this text, valve and fitting losses were calculated using an equivalent length of pipe rather than the coefficient  $K$ . The Crane Company states that this conceptual change regarding the values of equivalent length  $L/D$  and resistance coefficient  $K$  for valves and fittings relative to the friction factor in pipes has a relatively minor

TABLE 5B Resistance coefficients  $K$  for valves and fittings

effect on most problems dealing with turbulent flow and avoids a significant overstatement of pressure drop in the laminar zone.

**Valve Flow Coefficient** The loss of head through valves, particularly control valves, is often expressed in terms of a *flow coefficient*  $C_v$  in USCS units ( $K_v$  in SI units). The flow of water in gallons per minute (cubic meters per hour) at 60°F (15.6°C) that will pass through a valve with a 1-lb/in<sup>2</sup> (1-bar) pressure drop is defined as the flow coefficient for a particular valve opening. Because loss of head  $h$  is a measure of energy loss per unit weight (force) and because  $h = p/\gamma$  and head loss varies directly with the square of the flow through a certain fixed opening, the formulas for flow coefficient are

**TABLE 5C** Approximate variation for  $K$  listed in Tables 5a and 5b

	Fitting	Range of variation, %
90° elbow	Regular screwed	±20 above 2-in size <sup>a</sup>
	Regular screwed	±40 below 2-in size
	Long radius, screwed	±25
	Regular flanged	±35
45° elbow	Long radius, flanged	±30
	Regular screwed	±10
180° bend	Long radius, flanged	±10
	Regular screwed	±25
	Regular flanged	±35
T	Long radius, flanged	±30
	Screwed, line or branch flow	±25
Globe valve	Flanged, line or branch flow	±35
	Screwed	±25
Gate valve	Flanged	±25
	Screwed	±25
Check valve <sup>b</sup>	Flanged	±50
	Screwed	±30
	Flanged	{ +200 -80
Sleeve check valve	—	Multiply flanged values by 0.2 to 0.5
Tilting check valve	—	Multiply flanged values by 0.13 to 0.19
Drainage gate check	—	Multiply flanged values by 0.03 to 0.07
Angle valve	Screwed	±20
	Flanged	±50
Basket strainer	—	±50
Foot valve <sup>a</sup>	—	±50
Couplings	—	±50
Unions	—	±50
Reducers	—	±50

<sup>a</sup>In 3 25.4 = mm.

<sup>b</sup>For velocities below 15 ft/s (4.6 m/s), check valves and foot valves will be only partially open and will exhibit higher values of  $K$  than shown.

Source: Reference 9.

$$\text{In USCS units} \quad C_v = \text{gpm} \sqrt{\frac{\text{sp. gr.}}{\text{lb/in}^2}} \quad (21a)$$

$$\text{also} \quad C_v = 29.9d^2/\sqrt{K} \quad (22a)$$

$$\text{In SI units} \quad K_v = \text{m}^3/\text{h} \sqrt{\frac{\text{sp. gr.}}{\text{bar}}} \quad (21b)$$

$$\text{also} \quad K_v = 0.04d^2/\sqrt{K} \quad (22b)$$

where  $d$  = internal diameter of pipe corresponding to  $K$  and as shown in Table 6e, in (mm) and 1 bar = 100 kPa. The conversion from the SI flow coefficient to the USCS flow coefficient is

**TABLE 6A** Resistance coefficient  $K$  for valves and fittings

PIPE FRICTION DATA FOR CLEAN COMMERCIAL STEEL PIPE WITH FLOW IN ZONE OF COMPLETE TURBULENCE													
Nominal Size	1/2"	3/4"	1"	1 1/4"	1 1/2"	2"	2 1/2, 3"	4"	5"	6"	8-10"	12-16"	18-24"
Friction Factor ( $f_t$ )	.027	.025	.023	.022	.021	.019	.018	.017	.016	.015	.014	.013	.012

**FORMULAS FOR CALCULATING "K" FACTORS  
FOR VALVES AND FITTINGS WITH REDUCED PORT**

• Formula 1

$$K_2 = \frac{0.8 \sin \frac{\theta}{2} (1 - \beta^2)}{\beta^4} = \frac{K_1}{\beta^4}$$

• Formula 2

$$K_2 = \frac{0.5 (1 - \beta^2) \sqrt{\sin \frac{\theta}{2}}}{\beta^4} = \frac{K_1}{\beta^4}$$

• Formula 3

$$K_2 = \frac{2.6 \sin \frac{\theta}{2} (1 - \beta^2)^2}{\beta^4} = \frac{K_1}{\beta^4}$$

• Formula 4

$$K_2 = \frac{(1 - \beta^2)^2}{\beta^4} = \frac{K_1}{\beta^4}$$

• Formula 5

$$K_2 = \frac{K_1}{\beta^4} + \text{Formula 1} + \text{Formula 3}$$

$$K_2 = \frac{K_1 + \sin \frac{\theta}{2} [0.8 (1 - \beta^2) + 2.6 (1 - \beta^2)^2]}{\beta^4}$$

• Formula 6

$$K_2 = \frac{K_1}{\beta^4} + \text{Formula 2} - \text{Formula 4}$$

$$K_2 = \frac{K_1 + 0.5 \sqrt{\sin \frac{\theta}{2} (1 - \beta^2) + (1 - \beta^2)^2}}{\beta^4}$$

• Formula 7

$$K_2 = \frac{K_1}{\beta^4} + \beta \text{ (Formula 2 + Formula 4) when } \theta = 180^\circ$$

$$K_2 = \frac{K_1 + \beta [0.5 (1 - \beta^2) + (1 - \beta^2)^2]}{\beta^4}$$

NOTES:

$$\beta = \frac{d_1}{d_2}$$

$$\beta^2 = \left(\frac{d_1}{d_2}\right)^2 = \frac{a_1}{a_2}$$

Subscript 1 defines dimensions and coefficients with reference to the smaller diameter.

Subscript 2 refers to the larger diameter.

**SUDDEN AND GRADUAL CONTRACTION**



If:  $\theta \approx 45^\circ \dots \dots \dots K_2 = \text{Formula 1}$

$45^\circ < \theta < 180^\circ \dots \dots \dots K_2 = \text{Formula 2}$

**SUDDEN AND GRADUAL ENLARGEMENT**



If:  $\theta \approx 45^\circ \dots \dots \dots K_2 = \text{Formula 3}$

$45^\circ < \theta < 180^\circ \dots \dots \dots K_2 = \text{Formula 4}$

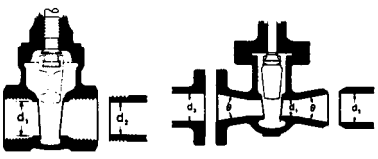
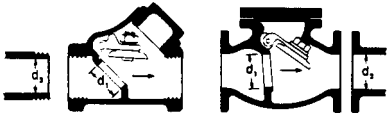
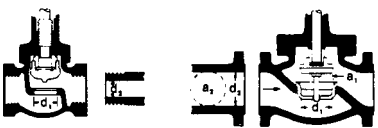
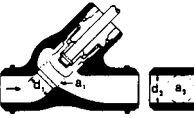
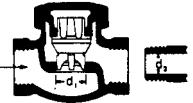
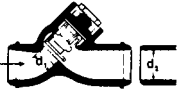
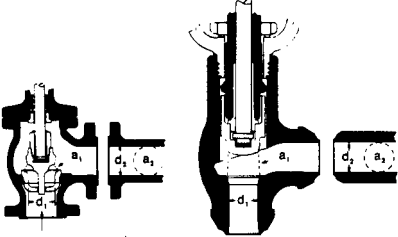
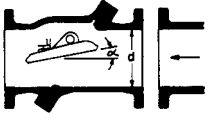
NOTE:  $K$  is based on use of schedule pipe as listed in Table 6e. In  $\times 25.4 = \text{mm}$ .

SOURCE: Reference 4.

$$C_v = 1.156K_v$$

**EXAMPLE 12** A pumping system consists of 20 ft (6.1 m) of 2-in (51-mm) suction pipe and 300 ft (91.5 m) of 1 1/2-in (38-mm) discharge pipe, both Schedule 40 new steel. Also included are a bell mouth inlet, a 90° short radius (SR) suction elbow, a full port suc-

TABLE 6B Resistance coefficient  $K$  for valves and fittings

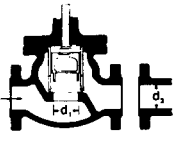
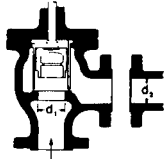

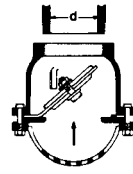
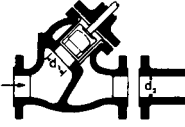
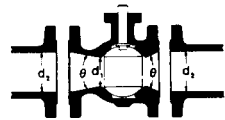

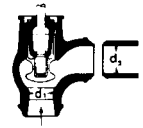
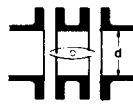
<p><b>GATE VALVES</b> Wedge Disc, Double Disc, or Plug Type</p>  <p>If: <math>\beta = 1, \theta = 0 \dots K_1 = 8 f_T</math>  <math>\beta &lt; 1</math> and <math>\theta \approx 45^\circ \dots K_2 = \text{Formula 5}</math>  <math>\beta &lt; 1</math> and <math>45^\circ &lt; \theta \approx 180^\circ \dots K_2 = \text{Formula 6}</math></p>	<p><b>SWING CHECK VALVES</b></p>  <p><math>K = 100 f_T</math>      <math>K = 50 f_T</math></p> <p>Minimum pipe velocity (fps) for full disc lift = <math>35 \sqrt{V}</math>      Minimum pipe velocity (fps) for full disc lift = <math>48 \sqrt{V}</math></p>															
<p><b>GLOBE AND ANGLE VALVES</b></p>  <p>If: <math>\beta = 1 \dots K_1 = 340 f_T</math></p>  <p>If: <math>\beta = 1 \dots K_1 = 55 f_T</math></p>	<p><b>LIFT CHECK VALVES</b></p>  <p>If: <math>\beta = 1 \dots K_1 = 600 f_T</math>  <math>\beta &lt; 1 \dots K_2 = \text{Formula 7}</math></p> <p>Minimum pipe velocity (fps) for full disc lift = <math>40 \beta^2 \sqrt{V}</math></p>  <p>If: <math>\beta = 1 \dots K_1 = 55 f_T</math>  <math>\beta &lt; 1 \dots K_2 = \text{Formula 7}</math></p> <p>Minimum pipe velocity (fps) for full disc lift = <math>140 \beta^2 \sqrt{V}</math></p>															
<p><b>GLOBE AND ANGLE VALVES (continued)</b></p>  <p>If: <math>\beta = 1 \dots K_1 = 150 f_T</math>      If: <math>\beta = 1 \dots K_1 = 55 f_T</math></p> <p>All globe and angle valves, whether reduced seat or throttled,          If: <math>\beta &lt; 1 \dots K_2 = \text{Formula 7}</math></p>	<p><b>TILTING DISC CHECK VALVES</b></p>  <table border="1" data-bbox="574 1093 947 1236"> <thead> <tr> <th></th> <th><math>\alpha = 5^\circ</math></th> <th><math>\alpha = 15^\circ</math></th> </tr> </thead> <tbody> <tr> <td>Sizes 2 to 8" ... <math>K =</math></td> <td>40 <math>f_T</math></td> <td>120 <math>f_T</math></td> </tr> <tr> <td>Sizes 10 to 14" ... <math>K =</math></td> <td>30 <math>f_T</math></td> <td>90 <math>f_T</math></td> </tr> <tr> <td>Sizes 16 to 48" ... <math>K =</math></td> <td>20 <math>f_T</math></td> <td>60 <math>f_T</math></td> </tr> <tr> <td>Minimum pipe velocity (fps) for full disc lift =</td> <td><math>80 \sqrt{V}</math></td> <td><math>30 \sqrt{V}</math></td> </tr> </tbody> </table>		$\alpha = 5^\circ$	$\alpha = 15^\circ$	Sizes 2 to 8" ... $K =$	40 $f_T$	120 $f_T$	Sizes 10 to 14" ... $K =$	30 $f_T$	90 $f_T$	Sizes 16 to 48" ... $K =$	20 $f_T$	60 $f_T$	Minimum pipe velocity (fps) for full disc lift =	$80 \sqrt{V}$	$30 \sqrt{V}$
	$\alpha = 5^\circ$	$\alpha = 15^\circ$														
Sizes 2 to 8" ... $K =$	40 $f_T$	120 $f_T$														
Sizes 10 to 14" ... $K =$	30 $f_T$	90 $f_T$														
Sizes 16 to 48" ... $K =$	20 $f_T$	60 $f_T$														
Minimum pipe velocity (fps) for full disc lift =	$80 \sqrt{V}$	$30 \sqrt{V}$														

tion gate valve of Class 150 steel, a full port discharge gate valve of Class 400 steel, and a swing check valve. The valves and fittings are screw-connected and the same size as the connecting pipe.

Determine the pipe, valve, and fitting losses when 60°F (15.6°C) oil having a specific gravity of 0.855 is pumped at a rate of 60 gpm (13.6 m³/h). Use resistance coefficients from Tables 5.

The inner diameter of the suction pipe is 2.067 in (52.5mm), and from Figure 32.  $\epsilon/D = 0.00087$ . From Eq. 9,

**TABLE 6C** Resistance coefficient  $K$  for valves and fittings

<b>STOP-CHECK VALVES (Globe and Angle Types)</b>		<b>FOOT VALVES WITH STRAINER</b>	
		<b>Poppet Disc</b> 	<b>Hinged Disc</b> 
If: $\beta = 1 \dots K_1 = 400 f_T$ $\beta < 1 \dots K_2 = \text{Formula 7}$	If: $\beta = 1 \dots K_1 = 200 f_T$ $\beta < 1 \dots K_2 = \text{Formula 7}$	$K = 420 f_T$	$K = 75 f_T$
Minimum pipe velocity for full disc lift $= 55 \beta^2 \sqrt{V}$	Minimum pipe velocity for full disc lift $= 75 \beta^2 \sqrt{V}$	Minimum pipe velocity (fps) for full disc lift $= 15 \sqrt{V}$	Minimum pipe velocity (fps) for full disc lift $= 35 \sqrt{V}$
		<b>BALL VALVES</b> 	
If: $\beta = 1 \dots K_1 = 300 f_T$ $\beta < 1 \dots K_2 = \text{Formula 7}$	If: $\beta = 1 \dots K_1 = 350 f_T$ $\beta < 1 \dots K_2 = \text{Formula 7}$	If: $\beta = 1, \theta = 0 \dots K_1 = 3 f_T$ $\beta < 1$ and $\theta \approx 45^\circ \dots K_2 = \text{Formula 5}$ $\beta < 1$ and $45^\circ < \theta \approx 180^\circ \dots K_2 = \text{Formula 6}$	
Minimum pipe velocity (fps) for full disc lift $= 60 \beta^2 \sqrt{V}$			
		<b>BUTTERFLY VALVES</b> 	
If: $\beta = 1 \dots K_1 = 55 f_T$ $\beta < 1 \dots K_2 = \text{Formula 7}$	If: $\beta = 1 \dots K_1 = 55 f_T$ $\beta < 1 \dots K_2 = \text{Formula 7}$	Sizes 2 to 8" ... $K = 45 f_T$ Sizes 10 to 14" ... $K = 35 f_T$ Sizes 16 to 24" ... $K = 25 f_T$	
Minimum pipe velocity (fps) for full disc lift $= 140 \beta^2 \sqrt{V}$			

In USCS units,  $V = \frac{\text{gpm}}{(\text{pipe ID in inches})^2} \times 0.408 = \frac{60}{2.067^2} \times 0.408 = 5.73 \text{ ft}$

$VD'' = 5.73 \times 2.067 = 11.8 \text{ ft/s} \times \text{in}$

In SI units  $V = \frac{\text{m}^3/\text{h}}{(\text{pipe ID in cm})^2} \times 3.54 = \frac{13.6}{5.25^2} \times 3.54 = 1.75 \text{ m/s}$

TABLE 6D Resistance coefficient  $K$  for valves and fittings

PLUG VALVES AND COCKS			STANDARD ELBOWS																													
<b>Straight-Way</b>	<b>3-Way</b>	<b>View X-X</b>	<b>90°</b>	<b>45°</b>																												
If: $\beta = 1$ , $K_1 = 18 f_T$	If: $\beta = 1$ , $K_1 = 30 f_T$	If: $\beta = 1$ , $K_1 = 90 f_T$	$K = 30 f_T$	$K = 16 f_T$																												
If: $\beta < 1 \dots K_2 = \text{Formula 6}$																																
<b>MITRE BENDS</b>																																
	<table border="1"> <thead> <tr> <th><math>\alpha</math></th> <th><math>K</math></th> </tr> </thead> <tbody> <tr><td>0°</td><td>2 <math>f_T</math></td></tr> <tr><td>15°</td><td>4 <math>f_T</math></td></tr> <tr><td>30°</td><td>8 <math>f_T</math></td></tr> <tr><td>45°</td><td>15 <math>f_T</math></td></tr> <tr><td>60°</td><td>25 <math>f_T</math></td></tr> <tr><td>75°</td><td>40 <math>f_T</math></td></tr> <tr><td>90°</td><td>60 <math>f_T</math></td></tr> </tbody> </table>				$\alpha$	$K$	0°	2 $f_T$	15°	4 $f_T$	30°	8 $f_T$	45°	15 $f_T$	60°	25 $f_T$	75°	40 $f_T$	90°	60 $f_T$												
$\alpha$	$K$																															
0°	2 $f_T$																															
15°	4 $f_T$																															
30°	8 $f_T$																															
45°	15 $f_T$																															
60°	25 $f_T$																															
75°	40 $f_T$																															
90°	60 $f_T$																															
<b>90° PIPE BENDS AND FLANGED OR BUTT-WELDING 90° ELBOWS</b>																																
	<table border="1"> <thead> <tr> <th><math>r/d</math></th> <th><math>K</math></th> <th><math>r/d</math></th> <th><math>K</math></th> </tr> </thead> <tbody> <tr><td>1</td><td>20 <math>f_T</math></td><td>8</td><td>24 <math>f_T</math></td></tr> <tr><td>1.5</td><td>14 <math>f_T</math></td><td>10</td><td>30 <math>f_T</math></td></tr> <tr><td>2</td><td>12 <math>f_T</math></td><td>12</td><td>34 <math>f_T</math></td></tr> <tr><td>3</td><td>12 <math>f_T</math></td><td>14</td><td>38 <math>f_T</math></td></tr> <tr><td>4</td><td>14 <math>f_T</math></td><td>16</td><td>42 <math>f_T</math></td></tr> <tr><td>6</td><td>17 <math>f_T</math></td><td>20</td><td>50 <math>f_T</math></td></tr> </tbody> </table>				$r/d$	$K$	$r/d$	$K$	1	20 $f_T$	8	24 $f_T$	1.5	14 $f_T$	10	30 $f_T$	2	12 $f_T$	12	34 $f_T$	3	12 $f_T$	14	38 $f_T$	4	14 $f_T$	16	42 $f_T$	6	17 $f_T$	20	50 $f_T$
$r/d$	$K$	$r/d$	$K$																													
1	20 $f_T$	8	24 $f_T$																													
1.5	14 $f_T$	10	30 $f_T$																													
2	12 $f_T$	12	34 $f_T$																													
3	12 $f_T$	14	38 $f_T$																													
4	14 $f_T$	16	42 $f_T$																													
6	17 $f_T$	20	50 $f_T$																													
The resistance coefficient, $K_B$ , for pipe bends other than 90° may be determined as follows:																																
$K_B = (n - 1) \left( 0.25 \pi f_T \frac{r}{d} + 0.5 K \right) + K$																																
$n$ = number of 90° bends																																
$K$ = resistance coefficient for one 90° bend (per table)																																
<b>PIPE ENTRANCE</b>																																
<b>Inward Projecting</b>	<table border="1"> <thead> <tr> <th><math>r/d</math></th> <th><math>K</math></th> </tr> </thead> <tbody> <tr><td>0.00°</td><td>0.5</td></tr> <tr><td>0.02</td><td>0.28</td></tr> <tr><td>0.04</td><td>0.24</td></tr> <tr><td>0.06</td><td>0.15</td></tr> <tr><td>0.10</td><td>0.09</td></tr> <tr><td>0.15 &amp; up</td><td>0.04</td></tr> </tbody> </table>			$r/d$	$K$	0.00°	0.5	0.02	0.28	0.04	0.24	0.06	0.15	0.10	0.09	0.15 & up	0.04	<b>Flush</b>														
$r/d$	$K$																															
0.00°	0.5																															
0.02	0.28																															
0.04	0.24																															
0.06	0.15																															
0.10	0.09																															
0.15 & up	0.04																															
	$K = 0.78$																															
*Sharp-edged																																
For $K$ , see table																																
<b>PIPE EXIT</b>																																
<b>Projecting</b>	<b>Sharp-Edged</b>	<b>Rounded</b>																														
$K = 1.0$	$K = 1.0$	$K = 1.0$																														
<b>CLOSE PATTERN RETURN BENDS</b>																																
$K = 50 f_T$																																

$$VD = 1.75 \times 0.0525 = 0.0919 \text{ m/s} \times \text{m}$$

$$(VD'' = 0.0919 \times 129.2 = 11.8 \text{ ft/s} \times \text{in})$$

From Figure 33,  $Re = 1 \times 10^4$ , and from Figure 31,  $f = 0.031$ . From Eq. 16

in USCS units 
$$h_{fs} = 0.031 \frac{20 \times 12}{2.067} \times \frac{5.73^2}{2 \times 32.17} = 1.84 \text{ ft}$$



**TABLE 6E** Pipe schedule for different classes of valves and fittings associated with  $K$  factors used in Tables 6A to 6D

Glass	Schedule
300 and lower	40
400 and 600	80
900	120
1500	160
2500 (Sizes $\frac{1}{2}$ to 6 in) <sup>a</sup>	XXS
2500 (sizes 8 in and up) <sup>a</sup>	160

<sup>a</sup>In  $\times 25.4 =$  mm.  
Source: Reference 4.

$$\text{In SI units} \quad h_{fs} = 0.031 \frac{6.1}{0.0525} \times \frac{1.75^2}{2 \times 9.807} = 0.56 \text{ m}$$

The inner diameter of the discharge pipe is 1.610 in (40.89 mm), and from Figure 32,  $\epsilon/D = 0.0011$ . From Eq. 9

$$\begin{aligned} \text{in USCS units} \quad V &= \frac{60}{1.601^2} \times 0.408 = 9.44 \text{ ft/s} \\ VD'' &= 9.44 \times 1.601 = 15.2 \text{ ft/s} \times \text{in} \end{aligned}$$

$$\begin{aligned} \text{in SI units} \quad V &= \frac{13.6}{4.089^2} \times 3.54 = 2.88 \text{ m/s} \\ VD &= 2.88 \times 0.04089 = 0.118 \text{ m/s} \times \text{m} \\ (VD'' &= 0.118 \times 129.2 = 15.2 \text{ ft/s} \times \text{in}) \end{aligned}$$

From Figure 33,  $Re = 1.5 \times 10^4$ , and from Figure 31,  $f = 0.030$ . From Eq. 16

$$\begin{aligned} \text{in USCS units} \quad h_{fd} &= 0.030 \frac{300 \times 12}{1.610} \times \frac{9.44^2}{2 \times 32.17} = 9.29 \text{ ft} \\ \text{in SI units} \quad h_{fd} &= 0.030 \frac{91.5}{0.04089} \times \frac{2.88^2}{2 \times 9.807} = 28.39 \text{ m} \end{aligned}$$

The valve and fitting losses from Tables 5 and Eq. 20 are 2-in (51-mm) bellmouth,  $K = 0.05$ :

$$\text{In USCS units} \quad h_{f1} = 0.05 \frac{5.73^2}{2 \times 32.17} = 0.026 \text{ ft}$$

$$\text{In SI units} \quad h_{f1} = 0.05 \frac{1.75^2}{2 \times 9.807} = 0.0078 \text{ m}$$

$$\text{2-in (51-mm) SR } 90^\circ \text{ elbow,} \quad K = 0.95 \pm 30\%$$

$$\text{In USCS units} \quad h_{f2} = 0.95 \frac{5.73^2}{2 \times 32.17} = 0.48 \pm 0.14 \text{ ft}$$

$$\text{In SI units} \quad h_{f2} = 0.95 \frac{1.75^2}{2 \times 9.807} = 0.15 \pm 0.044 \text{ m}$$

$$\text{2-in (51-mm) gate valve,} \quad K = 0.16 \pm 25\%$$

$$\text{In USCS units} \quad h_{f3} = 0.16 \frac{5.73^2}{2 \times 32.17} = 0.082 \pm 0.021 \text{ ft}$$

In SI units  $h_{f3} = 0.16 \frac{1.75^2}{2 \times 9.807} = 0.0250 \pm 0.0062 \text{ m}$   
 $1\frac{1}{2}$ -in (38-mm) gate valve,  $K = 0.19 \pm 25\%$

In USCS units  $h_{f4} = 0.19 \frac{9.44^2}{2 \times 32.17} = 2.63 \pm 0.066 \text{ ft}$

In SI units  $h_{f4} = 0.19 \frac{2.88^2}{2 \times 9.807} = 0.0803 \pm 0.02 \text{ m}$

$1\frac{1}{2}$ -in (38-mm) swing check valve,  $K = 2.5 \pm 30\%$

In USCS units  $h_{f5} = 2.5 \frac{9.44^2}{2 \times 32.17} = 3.46 \pm 1.0 \text{ ft}$

In SI units  $h_{f5} = 2.5 \frac{2.88^2}{2 \times 9.807} = 1.06 \pm 0.32 \text{ m}$

The total pipe, valve, and fitting losses are

In USCS units  $\Sigma h_f = h_{fs} + h_{fd} + h_{f1} + h_{f2} + h_{f3} + h_{f4} + h_{f5}$   
 $= 1.84 + 92.9 + 0.026 + 0.48 + 0.082 + 0.263$   
 $+ 3.46 = 99.05 \text{ ft}$

Total variation =  $\pm (0.14 + 0.021 + 0.066 + 1.0) = \pm 1.23 \text{ ft}$

In SI units  $\Sigma h_f = h_{fs} + h_{fd} + h_{f1} + h_{f2} + h_{f3} + h_{f4} + h_{f5}$   
 $= 0.56 + 28.39 + 0.0078 + 0.044 + 0.0250 + 0.0803$   
 $+ 1.06 = 30.17 \text{ m}$

Total variation =  $\pm (0.044 + 0.0062 + 0.02 + 0.32) = \pm 0.39 \text{ m}$

EXAMPLE 13 Solve Example 12 using resistance coefficients from Tables 6.

Suction pipe:

In USCS units  $h_{fs} = 1.84 \text{ ft}$  (same as in Example 12)

In SI units  $h_{fs} = 0.56 \text{ m}$  (same as in Example 12)

Discharge pipe,

In USCS units  $h_{fd} = 92.9 \text{ ft}$  (same as in Example 12)

In SI units  $h_{fd} = 28.39 \text{ m}$  (same as in Example 12)

Valve and fitting losses from Tables 6 and Eq. 20: 2-in (51-mm) bellmouth,  $K = 0.04$

In USCS units  $h_{f1} = 0.04 \frac{5.73^2}{2 \times 32.17} = 0.020 \text{ ft}$

In SI units  $h_{f1} = 0.04 \frac{1.75^2}{2 \times 9.807} = 0.0062 \text{ m}$

2-in (51-mm) SR 90° elbow,  $K = 30 f_T$

$f_T = 0.019$  (from Table 6A)

$K = 30 \times 0.019 = 0.57$

In USCS units  $h_{f2} = 0.57 \frac{5.73^2}{2 \times 32.17} = 0.29 \text{ ft}$

$$\text{In SI units} \quad h_{f2} = 0.57 \frac{1.57^2}{2 \times 9.807} = 0.089 \text{ m}$$

$$\begin{aligned} \text{2-in (51-mm) gate valve,} \quad \beta = 1, \theta = 0, k = 8f_T \quad & \left( \beta = \frac{d_1}{d_2} = 1 \text{ from Table 6A} \right) \\ K = 8 \times 0.019 = 0.15 \end{aligned}$$

$$\text{In USCS units} \quad h_{f3} = 0.15 \frac{5.73^2}{2 \times 32.17} = 0.077 \text{ ft}$$

$$\text{In SI units} \quad h_{f3} = 0.15 \frac{1.75^2}{2 \times 9.807} = 0.023 \text{ m}$$

$$\begin{aligned} \text{1-in (38-mm) gate valve,} \quad \beta = 1, \theta = 0, K = 8f_T \quad & \text{for Schedule 80 (from Table 6E)} \\ K = 8f_T (1.10/1.500)^4 = 10.62f_T \quad & \text{for Schedule 40} \\ f_T = 0.021 \quad & \text{(from Table 6A)} \\ K = 10.62 \times 0.021 = 0.22 \end{aligned}$$

$$\text{In USCS units} \quad h_{f4} = 0.22 \frac{9.44^2}{2 \times 32.17} = 0.30 \text{ ft}$$

$$\text{In SI units} \quad h_{f4} = 0.22 \frac{2.88^2}{2 \times 9.807} = 0.093 \text{ m}$$

$$1\frac{1}{2}\text{-in (38-mm) swing check valve, } K = 100f_T \quad \text{(from Table 6B)}$$

$$\begin{aligned} \text{Minimum pipe velocity for full disk lift} &= 35\sqrt{V} = 35\sqrt{0.0189} = 4.81 \text{ ft/s} < 9.44 \text{ ft/s} \\ K &= 100 \times 0.021 = 2.1 \end{aligned}$$

$$\text{In USCS units} \quad h_{f5} = 2.1 \frac{9.44^2}{2 \times 32.17} = 2.91 \text{ ft}$$

$$\text{In SI units} \quad h_{f5} = 2.1 \frac{2.88^2}{2 \times 9.807} = 0.89 \text{ m}$$

Total pipe, valve, and fitting losses:

$$\begin{aligned} \text{In USCS units} \quad \Sigma h_f &= h_{fs} + h_{fd} + h_{f1} + h_{f2} + h_{f3} + h_{f4} + h_{f5} \\ &= 1.84 + 92.9 + 0.020 + 0.29 + 0.077 + 0.30 + 2.91 \\ &= 98.34 \text{ ft} \end{aligned}$$

$$\begin{aligned} \text{In SI units} \quad \Sigma h_f &= h_{fs} + h_{fd} + h_{f1} + h_{f2} + h_{f3} + h_{f4} + h_{f5} \\ &= 0.56 + 28.39 + 0.062 + 0.089 + 0.023 + 0.093 + 0.89 \\ &= 30.05 \text{ m} \end{aligned}$$

**INCREASERS** The head lost when there is a sudden increase in pipe diameter, with velocity changing from  $V_1$  to  $V_2$  in the direction of flow, can be calculated analytically. Computed results have been confirmed experimentally to be true to within  $\pm 3\%$ . The head loss is expressed as shown, with  $K$  computed to be equal to unity:

$$h = K \frac{(V_1 - V_2)^2}{2g} = K \left[ 1 - \left( \frac{D_1}{D_2} \right)^2 \right]^2 \frac{V_1^2}{2g} = K \left[ \left( \frac{D_2}{D_1} \right)^2 - 1 \right]^2 \frac{V_2^2}{2g} \quad (23)$$

The value of  $K$  is also approximately equal to unity if a pipe discharges into a relatively large reservoir. This indicates that all the kinetic energy  $V_1^2/2g$  is lost and  $V_2$  equals zero.

The loss of head for a gradual increase in pipe diameter when the flow is through a diffuser can be found from Figure 39 and Table 6A. The diffuser converts some of the kinetic

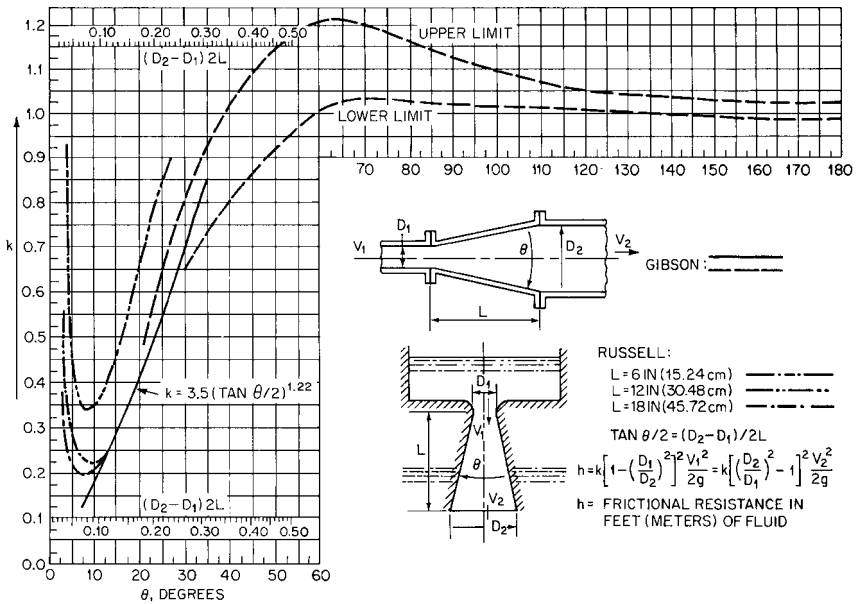


FIGURE 39 Resistance coefficients for increasers and diffusers ( $D =$  in or ft [m];  $V =$  ft/s [m/s]) (Hydraulic Institute Engineering Data Book, Reference 5)

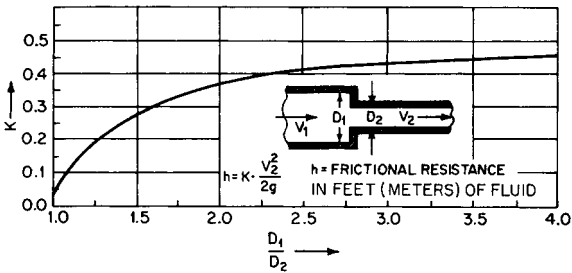
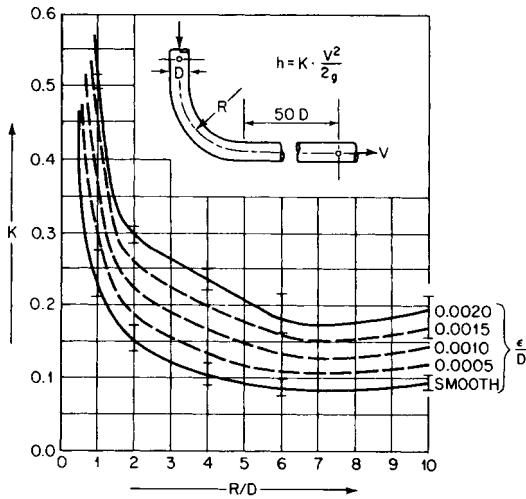


FIGURE 40 Resistance coefficients for reducers (Hydraulic Institute Engineering Data Book, Reference 5)

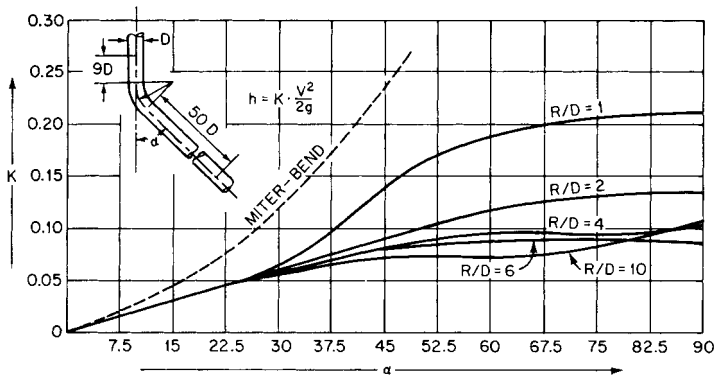
energy to pressure. Values for the coefficient used with Eq. 23 for calculating head loss are shown in Figure 39. The optimum total angle appears to be  $7.5^\circ$ . Angles greater than this result in shorter diffusers and less friction, but separation and turbulence occur. For angles greater than  $50^\circ$ , it is preferable to use a sudden enlargement.

**REDUCERS** Figure 40 and Table 6A give values of the resistance coefficient to be used for sudden reducers.

**BENDS** Figure 41 may be used to determine the resistance coefficient for  $90^\circ$  pipe bends of uniform diameter. Figure 42 gives resistance coefficients for bends that are less than  $90^\circ$  and can be used for surfaces having moderate roughness such as clean steel and cast iron. Figures 41 and 42 are not recommended for elbows with  $R/D$  below 1. Tables 6D and 7 give values of resistance coefficients for miter bends.



**FIGURE 41** Resistance coefficients for 90° bends of uniform diameter (Hydraulic Institute Engineering Data Book, Reference 5)









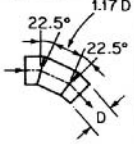
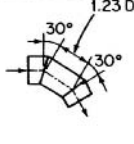
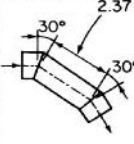
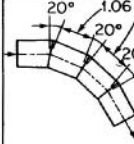
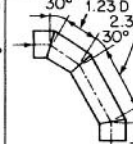
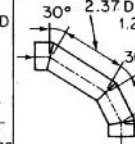
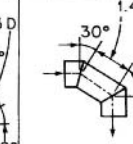
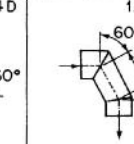
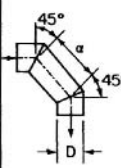
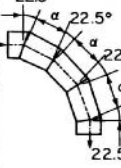
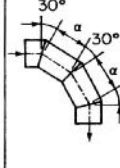
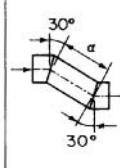


**FIGURE 42** Resistance coefficients for bends of uniform diameter and smooth surface at Reynolds number  $\approx 2.25 \times 10^5$  (Hydraulic Institute Engineering Data Book, Reference 5).

**PUMP SUCTION ELBOWS** Figures 43 and 44 illustrate two typical rectangular to round reducing suction elbows. Elbows of this configuration are sometimes used under dry-pit vertical volute pumps. These elbows are formed in concrete and are designed to require a minimum height, thus permitting a higher pump setting with reduced excavation. Figure 43 shows a long-radius elbow, and Figure 44 a short-radius elbow. The resulting velocity distribution into the impeller eye and the loss of head are shown for these two designs.

**METERS** Orifice, nozzle, and venturi meters (Figures 45–47) are used to measure rate of flow. These meters, however, introduce additional loss of head into the pumping system. Each of these meters is designed to create a pressure differential through the primary element. The magnitude of the pressure differential depends on the velocity and density of the liquid and the design of the element. The primary element restricts the area of flow, increases the velocity, and decreases the pressure. An expanding section following the pri-

**TABLE 7** Resistance coefficients for miter bends at reynolds number  $\approx 2.25 \times 10^5$

 <p><math>K_s = 0.016</math> <math>K_r = 0.024</math></p>	 <p><math>K_s = 0.034</math> <math>K_r = 0.044</math></p>	 <p><math>K_s = 0.042</math> <math>K_r = 0.062</math></p>	 <p><math>K_s = 0.065</math> <math>K_r = 0.154</math></p>	 <p><math>K_s = 0.130</math> <math>K_r = 0.165</math></p>	 <p><math>K_s = 0.236</math> <math>K_r = 0.320</math></p>	 <p><math>K_s = 0.471</math> <math>K_r = 0.684</math></p>	 <p><math>K_s = 1.129</math> <math>K_r = 1.265</math></p>																																																																																																																							
 <p><math>K_s = 0.112</math> <math>K_r = 0.204</math></p>	 <p><math>K_s = 0.150</math> <math>K_r = 0.268</math></p>	 <p><math>K_s = 0.143</math> <math>K_r = 0.227</math></p>	 <p><math>K_s = 0.108</math> <math>K_r = 0.236</math></p>	 <p><math>K_s = 0.188</math> <math>K_r = 0.320</math></p>	 <p><math>K_s = 0.202</math> <math>K_r = 0.323</math></p>	 <p><math>K_s = 0.400</math> <math>K_r = 0.534</math></p>	 <p><math>K_s = 0.400</math> <math>K_r = 0.601</math></p>																																																																																																																							
 <table border="1"> <thead> <tr> <th><math>a/D</math></th> <th><math>K_s</math></th> <th><math>K_r</math></th> </tr> </thead> <tbody> <tr><td>0.71</td><td>0.507</td><td>0.510</td></tr> <tr><td>0.943</td><td>0.230</td><td>0.415</td></tr> <tr><td>1.174</td><td>0.333</td><td>0.384</td></tr> <tr><td>1.42</td><td>0.261</td><td>0.377</td></tr> <tr><td>1.50*</td><td>0.280</td><td>0.376</td></tr> <tr><td>1.88</td><td>0.269</td><td>0.390</td></tr> <tr><td>2.58</td><td>0.338</td><td>0.429</td></tr> <tr><td>3.14</td><td>0.346</td><td>0.426</td></tr> <tr><td>3.72</td><td>0.356</td><td>0.490</td></tr> <tr><td>4.89</td><td>0.389</td><td>0.455</td></tr> <tr><td>5.59</td><td>0.392</td><td>0.444</td></tr> <tr><td>6.29</td><td>0.399</td><td>0.444</td></tr> </tbody> </table>	$a/D$	$K_s$	$K_r$	0.71	0.507	0.510	0.943	0.230	0.415	1.174	0.333	0.384	1.42	0.261	0.377	1.50*	0.280	0.376	1.88	0.269	0.390	2.58	0.338	0.429	3.14	0.346	0.426	3.72	0.356	0.490	4.89	0.389	0.455	5.59	0.392	0.444	6.29	0.399	0.444	 <table border="1"> <thead> <tr> <th><math>a/D</math></th> <th><math>K_s</math></th> <th><math>K_r</math></th> </tr> </thead> <tbody> <tr><td>1.86</td><td>0.120</td><td>0.294</td></tr> <tr><td>1.40</td><td>0.125</td><td>0.252</td></tr> <tr><td>1.50*</td><td>—</td><td>0.250</td></tr> <tr><td>2.25*</td><td>0.163</td><td>0.124</td></tr> <tr><td>1.86</td><td>0.117</td><td>0.272</td></tr> <tr><td>2.325</td><td>0.096</td><td>0.317</td></tr> <tr><td>2.40*</td><td>0.095</td><td>—</td></tr> <tr><td>2.91</td><td>0.108</td><td>0.317</td></tr> <tr><td>3.49</td><td>0.130</td><td>0.318</td></tr> <tr><td>4.65</td><td>0.148</td><td>0.310</td></tr> <tr><td>6.05</td><td>0.142</td><td>0.313</td></tr> </tbody> </table>	$a/D$	$K_s$	$K_r$	1.86	0.120	0.294	1.40	0.125	0.252	1.50*	—	0.250	2.25*	0.163	0.124	1.86	0.117	0.272	2.325	0.096	0.317	2.40*	0.095	—	2.91	0.108	0.317	3.49	0.130	0.318	4.65	0.148	0.310	6.05	0.142	0.313	 <table border="1"> <thead> <tr> <th><math>a/D</math></th> <th><math>K_s</math></th> <th><math>K_r</math></th> </tr> </thead> <tbody> <tr><td>1.23</td><td>0.195</td><td>0.347</td></tr> <tr><td>1.44</td><td>0.196</td><td>0.320</td></tr> <tr><td>1.67</td><td>0.150</td><td>0.300</td></tr> <tr><td>1.70*</td><td>0.149</td><td>0.299</td></tr> <tr><td>1.91</td><td>0.154</td><td>0.312</td></tr> <tr><td>2.37</td><td>0.167</td><td>0.337</td></tr> <tr><td>2.96</td><td>0.172</td><td>0.342</td></tr> <tr><td>4.11</td><td>0.190</td><td>0.354</td></tr> <tr><td>4.70</td><td>0.192</td><td>0.360</td></tr> <tr><td>6.10</td><td>0.201</td><td>0.360</td></tr> </tbody> </table>	$a/D$	$K_s$	$K_r$	1.23	0.195	0.347	1.44	0.196	0.320	1.67	0.150	0.300	1.70*	0.149	0.299	1.91	0.154	0.312	2.37	0.167	0.337	2.96	0.172	0.342	4.11	0.190	0.354	4.70	0.192	0.360	6.10	0.201	0.360	 <table border="1"> <thead> <tr> <th><math>a/D</math></th> <th><math>K_s</math></th> <th><math>K_r</math></th> </tr> </thead> <tbody> <tr><td>1.23</td><td>0.157</td><td>0.300</td></tr> <tr><td>1.67</td><td>0.156</td><td>0.378</td></tr> <tr><td>2.37</td><td>0.143</td><td>0.264</td></tr> <tr><td>3.77</td><td>0.160</td><td>0.242</td></tr> </tbody> </table>	$a/D$	$K_s$	$K_r$	1.23	0.157	0.300	1.67	0.156	0.378	2.37	0.143	0.264	3.77	0.160	0.242
$a/D$	$K_s$	$K_r$																																																																																																																												
0.71	0.507	0.510																																																																																																																												
0.943	0.230	0.415																																																																																																																												
1.174	0.333	0.384																																																																																																																												
1.42	0.261	0.377																																																																																																																												
1.50*	0.280	0.376																																																																																																																												
1.88	0.269	0.390																																																																																																																												
2.58	0.338	0.429																																																																																																																												
3.14	0.346	0.426																																																																																																																												
3.72	0.356	0.490																																																																																																																												
4.89	0.389	0.455																																																																																																																												
5.59	0.392	0.444																																																																																																																												
6.29	0.399	0.444																																																																																																																												
$a/D$	$K_s$	$K_r$																																																																																																																												
1.86	0.120	0.294																																																																																																																												
1.40	0.125	0.252																																																																																																																												
1.50*	—	0.250																																																																																																																												
2.25*	0.163	0.124																																																																																																																												
1.86	0.117	0.272																																																																																																																												
2.325	0.096	0.317																																																																																																																												
2.40*	0.095	—																																																																																																																												
2.91	0.108	0.317																																																																																																																												
3.49	0.130	0.318																																																																																																																												
4.65	0.148	0.310																																																																																																																												
6.05	0.142	0.313																																																																																																																												
$a/D$	$K_s$	$K_r$																																																																																																																												
1.23	0.195	0.347																																																																																																																												
1.44	0.196	0.320																																																																																																																												
1.67	0.150	0.300																																																																																																																												
1.70*	0.149	0.299																																																																																																																												
1.91	0.154	0.312																																																																																																																												
2.37	0.167	0.337																																																																																																																												
2.96	0.172	0.342																																																																																																																												
4.11	0.190	0.354																																																																																																																												
4.70	0.192	0.360																																																																																																																												
6.10	0.201	0.360																																																																																																																												
$a/D$	$K_s$	$K_r$																																																																																																																												
1.23	0.157	0.300																																																																																																																												
1.67	0.156	0.378																																																																																																																												
2.37	0.143	0.264																																																																																																																												
3.77	0.160	0.242																																																																																																																												

$K_s$  = RESISTANCE COEFFICIENT FOR SMOOTH SURFACE  
 $K_r$  = RESISTANCE COEFFICIENT FOR ROUGH SURFACE,  $\frac{\epsilon}{D} \approx 0.0022$

\*OPTIMUM VALUE OF  $\alpha$  INTERPOLATED

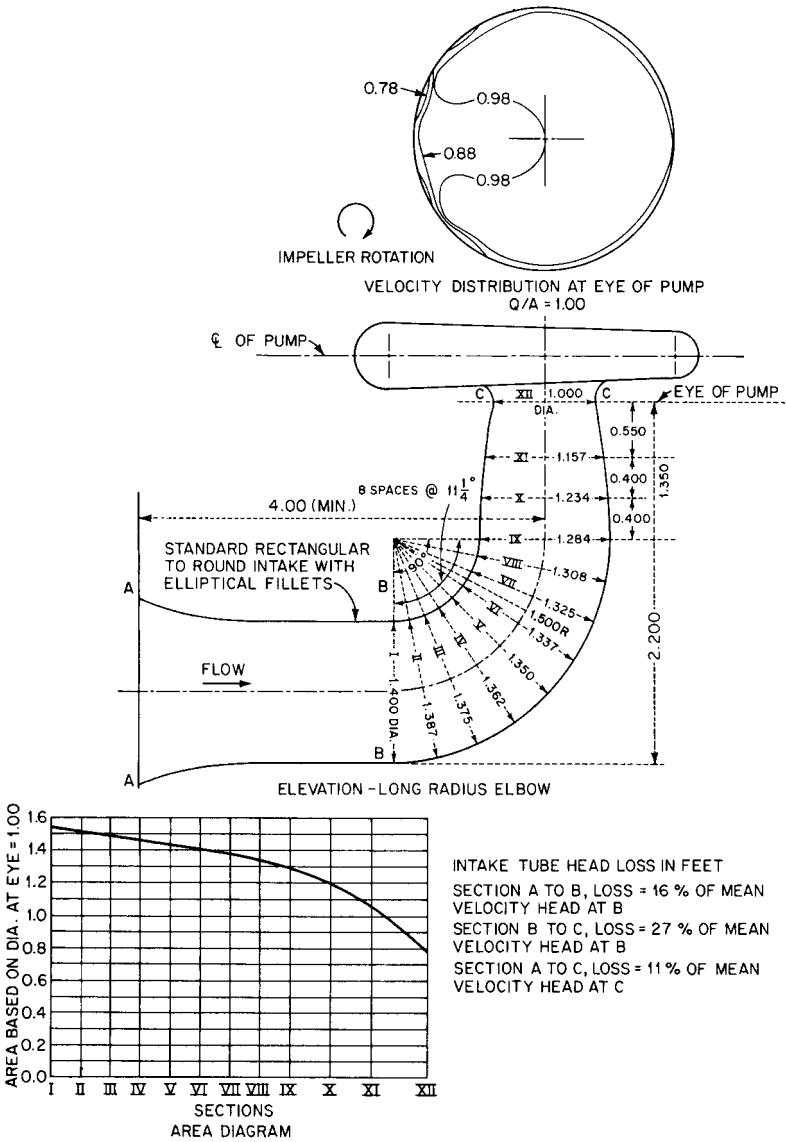


FIGURE 43 Head loss in a long-radius pump suction elbow (in  $\times 25.4 = \text{mm}$ ) (Reference 16)

many element provides pressure head recovery and determines the meter efficiency. The pressure differential between inlet and throat taps measure rate of flow; the pressure differential between inlet and outlet taps measures the meter head loss (an outlet tap is not usually provided). Of the three types, venturi meters offer the least resistance to flow, and orifice meters the most.

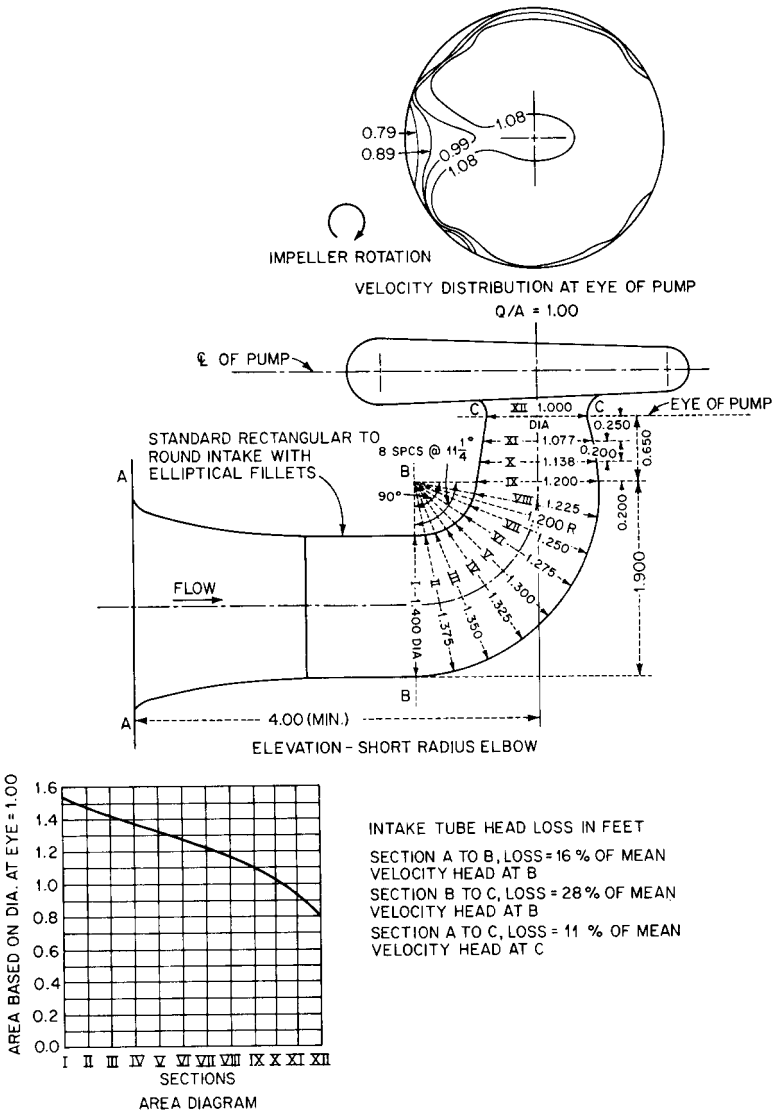


FIGURE 44 Head loss in a short-radius pump suction elbow (in  $\times 25.4 =$  mm) (Reference 16)

When meters are designed and pressure taps located as recommended,<sup>6</sup> Figures 48–50 may be used to estimate the overall pressure loss. In these figures, the loss of pressure is expressed as a percentage of the differential pressure measured at the appropriate taps and values are given for various sizes of meters. This loss of pressure is also the meter total head, or energy loss, because there is no change in velocity head if the pipe inside diameters are the same at the various measuring points. The meter loss of head should be in units of feet (meters) of liquid pumped if other system losses are expressed this way.



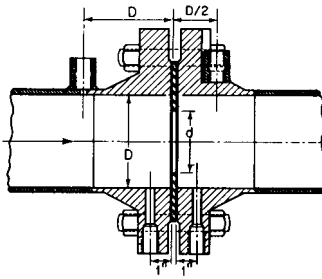


FIGURE 45 Thin-plate, square-edged orifice meter, showing alternate locations of pressure taps (Reference 6)

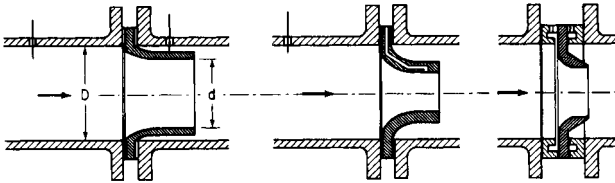


FIGURE 46 Shapes of flow nozzle meters and locations of pressure taps (Reference 6)

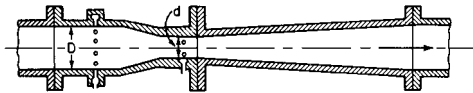


FIGURE 47 Herschel-type venturi meter, showing locations of pressure taps (Reference 6)

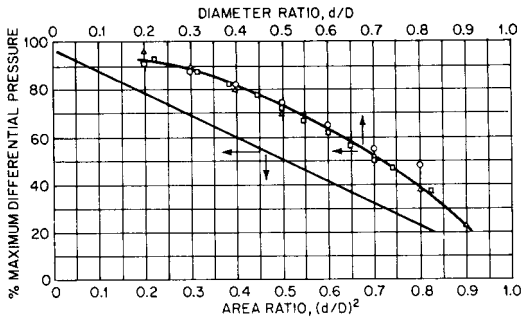


FIGURE 48 Overall pressure loss across thin-plate orifices (Reference 6)

Reference 6 should be consulted for information concerning formulas and coefficients for calculating differential pressure versus rate of flow.

**Screens, Perforated Plates, and Bar Racks** Obstructions to the flow of liquid in the form of multiple orifices uniformly distributed across an open or closed conduit may be used to remove solids, throttle flow, and produce or reduce turbulence. They may be used

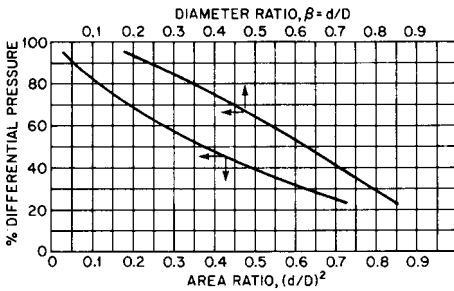


FIGURE 49 Overall pressure loss across flow nozzles (Reference 6)

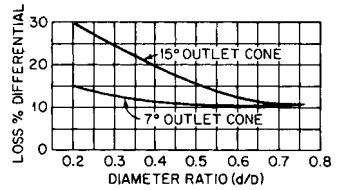


FIGURE 50 Overall pressure loss across venturi tubes (Reference 6)

upstream or downstream from a pump, depending on their purpose, and they therefore introduce a loss of head that must be accounted for. When an obstruction is placed upstream from a pump, a significant reduction in suction pressure and *NPSH* available can result.

The loss of head results from an increase in velocity at the entrance to the openings, friction, and the sudden decrease in velocity following the expansion of the numerous liquid jets. The total head loss is a function of the ratio of the total area of the openings to the area of the conduit before the obstruction, the thickness of the obstruction, the Reynolds number, and the velocities. Various investigators have determined values for resistance coefficients that can be multiplied by the approach velocity head to obtain the loss through these obstructions. According to Idel'chik,<sup>7</sup> loss of head  $h$  in feet (meters) may be calculated from the equation

$$h = K_1 \frac{V_1^2}{2g} \quad (24)$$

where  $K_1$  = resistance coefficient

$V_1$  = average velocity in the conduit approaching the obstruction, ft/s (m/s)

$g$  = acceleration of gravity, 32.17 ft/s<sup>2</sup> (9.807 m/s<sup>2</sup>)

**ROUND-WIRE MESH SCREENS** For flow having Reynolds numbers equal to or greater than 400, the resistance coefficient for flow through a round-wire, plain square mesh screen (Figure 51a) may be estimated as a function of percentage of open area using the equations

$$\text{in USCS units} \quad Re = \frac{V_o W_d}{v_{12}} \geq 400 \quad (25a)$$

$$\text{in SI units} \quad Re = \frac{V_o W_d}{v_{1000}} \geq 400 \quad (25b)$$

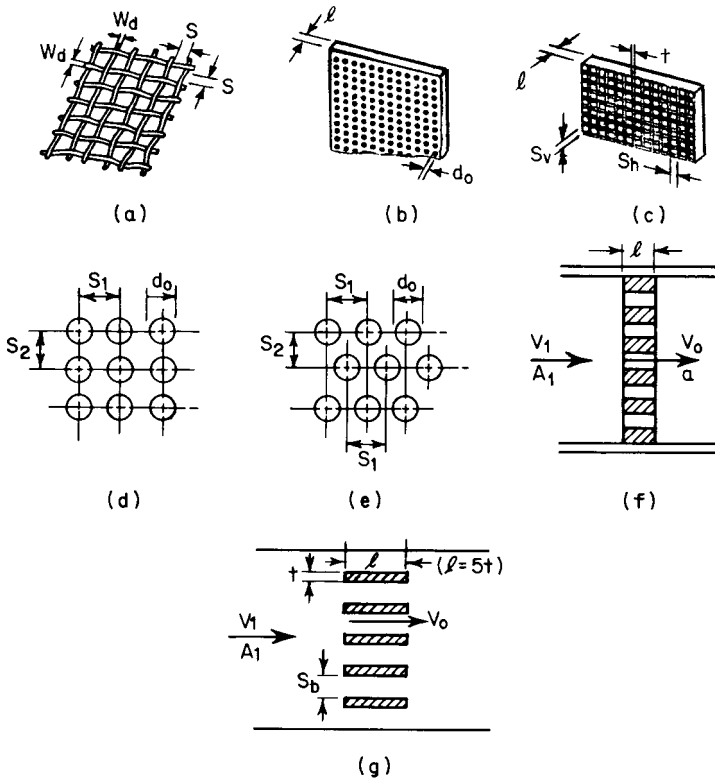
$$K_1 = k_0 \left( 1 - \frac{A_r}{100} \right) + \left( \frac{100}{A_r} - 1 \right)^2 \quad (26)$$

$$A_r = 100 \left( \frac{S}{S + W_d} \right)^2 \quad (27)$$

$$A_r = 100(1 - MW_d)^2 \quad (28)$$

where  $Re$  = screen Reynolds number referred to wire diameter

$V_o$  = velocity through area of rectangular opening =  $100V_1/A_r$ , ft/s (m/s)



**FIGURE 51** Explanation of terms used in Eq. 25–28 and 30–37 and Tables 8 and 9 for calculating resistance coefficient  $K_1$ , (a) round-wire, plain square, mesh screen, (b) round-hole perforated plate, (c) rectangular-grid perforated plate, (d) perforated plate, holes in vertical columns, (e) perforated plate, staggered holes, (f) perforated plate, cross section, (g) rectangular bar rack, cross section

$W_d$  = screen wire diameter, in (mm)

$\nu$  = kinematic viscosity, ft<sup>2</sup>/s (m<sup>2</sup>/s)

$k_0$  = 1.0 for new, perfectly clean screens to 1.3 for normal screens

$A_r$  = percentage of open area

$S$  = square space between wires, in (mm)

$M$  = mesh of screen or number of wires per in (mm)

Using water in a flow range of Reynolds numbers of approximately 60 to 800, Padmanabhan and Vigander<sup>8</sup> experimented with 1.3- to 12.0-mesh screens, 51.4 to 56% open area, and found their results to be comparable with those of other investigators. Values of the coefficient of resistance  $K_1$ , from the Padmanabhan-Vigander tests and others, vary from 2 decreasing asymptotically to 1 with increase in Reynolds number (Eq. 25) up to approximately 1000 for 47 to 56% open area. Smaller percentage open area values have larger coefficients.

Armour and Cannon,<sup>9</sup> using nitrogen as the fluid, tested various types of fine woven wire screens and derived equations for pressure drop in terms of a friction factor and the screen Reynolds number. Approach velocities ranged from 0.1 to 30 ft/s (0.03 to 9 m/s),

**TABLE 8** Plain square screen geometry

Screen mesh size $M$ , in <sup>-1</sup> (mm <sup>-1</sup> )	Wire diameter	Open area $A_r$ , %	Screen constant $C_1$ , ft <sup>-1</sup> × 10 <sup>3</sup> (m <sup>-1</sup> × 10 <sup>3</sup> )	Screen constant $C_2$
	$W_d$ , in × 10 <sup>-4</sup> (mm × 10 <sup>-4</sup> )			
30 × 30 (1.18 × 1.18)	9.45 (240)	94.4	2.553 (8.376)	1.553
150 × 150 (5.91 × 5.91)	2.36 (59.9)	93.0	8.267 (27.12)	2.594
250 × 250 (9.84 × 9.84)	1.69 (42.9)	91.7	16.21 (53.18)	2.934
400 × 400 (15.7 × 15.7)	1.00 (25.4)	92.2	30.68 (100.7)	2.680

Source: Reference 9.

resulting in Reynolds numbers from 350 to 275,000. To simplify calculations, screen geometry constants  $C_1 = (\text{surface area to unit volume ratio})^2 \times (\text{pore diameter})$  and  $C_2 = (\text{screen thickness}) \div (\text{void fraction})^2 \times (\text{pore diameter})$  have been added to the reference authors' equations to obtain the following expression for screen head loss  $h$  in feet (meters):

$$h = C_2 \frac{V_1}{g} (8.61vC_1 + 0.52V_1) \quad (29)$$

where  $V_1 =$  average velocity in the conduit approaching the screen, ft/s (m/s)

Table 8 lists  $C_1$  and  $C_2$  values for a sample of plain square screens tested by Armour and Cannon.

**PERFORATED PLATES AND BAR RACKS** For flow having Reynolds numbers equal to or greater than  $10^5$ , the resistance coefficients for flow through thick, square-edge perforated plates with round (Figure 51b) or rectangular (Figure 51c) openings and racks with rectangular cross-section bars (length = 5 times thickness; Figure 51g) may be calculated using Eq. 24, Table 9, and the following equations:

$$Re = \frac{V_o D_h}{\nu} \geq 10^5 \quad (30)$$

In USCS units 
$$D_h = \frac{a}{3p} \quad \text{or} \quad D_h = \frac{d_o}{12} \quad (31a)$$

In SI units 
$$D_h = 0.004 \frac{a}{\rho} \quad \text{or} \quad D_h = \frac{d_o}{1000} \quad (31b)$$

for plates with round holes 
$$A_r = 100 \left( \frac{0.785d_o^2}{S_1 S_2} \right) \quad (32)$$

for plates with single hole in center 
$$A_r = 100 \left( \frac{d_o}{d_1} \right)^2 \quad (33)$$

for plates with square openings ( $S = S_h = S_v$ ) 
$$A_r = 100 \left( \frac{S}{S + t} \right)^2 \quad (34)$$

for plates with rectangular openings 
$$A_r = 100 \left[ \frac{S_h S_v}{(S_h + t)(S_v + t)} \right] \quad (35)$$

for any plate or bar rack 
$$A_r = 100 \frac{A_o}{A_1} \quad (36)$$

for single vertical or horizontal bar racks 
$$A_r = 100 \left( \frac{S_b}{S_b + t} \right) \quad (37)$$

**TABLE 9** Values of resistance coefficient  $K_1$  for perforated plates and bar racks

$l/Dh$	$A_r/100$ or $A_o/A_1$															
	0.02	0.04	0.06	0.08	0.10	0.15	0.20	0.25	0.30	0.40	0.50	0.60	0.70	0.80	0.90	1.0
0	7000	1670	730	400	245	96.0	51.5	30.0	18.2	8.25	4.00	2.00	0.97	0.42	0.13	0
0.2	6600	1600	687	374	230	94.0	48.0	28.0	17.4	7.70	3.75	1.87	0.91	0.40	0.13	0.01
0.4	6310	1530	660	356	221	89.0	46.0	26.5	16.6	7.40	3.60	1.80	0.88	0.39	0.13	0.01
0.6	5700	1380	590	322	199	81.0	42.0	24.0	15.0	6.60	3.20	1.60	0.80	0.36	0.13	0.01
0.8	4680	1130	486	264	164	66.0	34.0	19.6	12.2	5.50	2.70	1.34	0.66	0.31	0.12	0.02
1.0	4260	1030	443	240	149	60.0	31.0	17.8	11.1	5.00	2.40	1.20	0.61	0.29	0.11	0.02
1.4	3930	950	408	221	137	55.6	28.4	16.4	10.3	4.60	2.25	1.15	0.58	0.28	0.11	0.03
2.0	3770	910	391	212	134	53.0	27.4	15.8	9.90	4.40	2.20	1.13	0.58	0.28	0.12	0.04
3.0	3765	913	392	214	132	53.5	27.5	15.9	10.0	4.50	2.24	1.17	0.61	0.31	0.15	0.06
4.0	3775	930	400	215	132	53.8	27.7	16.2	10.0	4.60	2.25	1.20	0.64	0.35	0.16	0.08
5.0	3850	936	400	220	133	55.5	28.5	16.5	10.5	4.75	2.40	1.28	0.69	0.37	0.19	0.10
6.0	3870	940	400	222	133	55.8	28.5	16.6	10.5	4.80	2.42	1.32	0.70	0.40	0.21	0.12
7.0	4000	950	405	230	135	55.9	29.0	17.0	10.9	5.00	2.50	1.38	0.74	0.43	0.23	0.14
8.0	4000	965	410	236	137	56.0	30.0	17.2	11.1	5.10	2.58	1.45	0.80	0.45	0.25	0.16
9.0	4080	985	420	240	140	57.0	30.0	17.4	11.4	5.30	2.62	1.50	0.82	0.50	0.28	0.18
10	4110	1000	430	245	146	59.7	31.0	18.2	11.5	5.40	2.80	1.57	0.89	0.53	0.32	0.20

Note:  $l$  = thickness of perforated plate or length of bars, ft (m);  $D_h$ ,  $A_r$ ,  $A_o$ , and  $A_1$  are as defined following Eq. 37.

Source: Reference 7.

where  $Re$  = Reynolds number referred to hydraulic diameter

$V_o$  = velocity through area of opening, ft/s (m/s)

$D_h$  = hydraulic diameter (= diameter if openings are round holes), ft (m)

$\nu$  = kinematic viscosity, ft<sup>2</sup>/s (m<sup>2</sup>/s)

$a$  = area of single opening, in<sup>2</sup> (mm<sup>2</sup>)

$p$  = perimeter of single opening, in (mm)

$d_o$  = diameter of hole, in (mm)

$A_r$  = percentage of open area

$S_1$  = horizontal spacing of holes, in (mm)

$S_2$  = vertical spacing of holes, in (mm)

$d_1$  = diameter of approach, in (mm)

$S_h$  = horizontal apace between vertical bars, in (mm)

$S_v$  = vertical space between horizontal bars, in (mm)

$t$  = thickness of plate laths or bars, in (mm)

$A_o$  = total area of openings, ft<sup>2</sup> (m<sup>2</sup>)

$A_1$  = total area of approach, ft<sup>2</sup> (m<sup>2</sup>)

$S_b$  = space between single vertical or horizontal bars, in (mm)

The loss of head through perforated plates may also be calculated by using an *orifice coefficient*  $C$ , as suggested by Smith and Van Winkle<sup>10</sup> and Kolodzie and Van Winkle.<sup>11</sup> Test results using air and other gases with equilateral-triangle pitch perforated plates are shown in Table 10 for Reynolds numbers 400 to 20,000. Using single-orifice relations, the following expression equates flow rate to pressure drop:

$$\omega = CA_o \sqrt{\frac{2g\Delta P}{\gamma \left[ 1 - \left( \frac{A_r}{100} \right)^2 \right]}} \quad (38)$$

where  $\omega$  = flow rate, ft<sup>3</sup>/s (m<sup>3</sup>/s)

$C$  = orifice coefficient from Table 10

$A_o$  = total area of openings, ft<sup>2</sup> (m<sup>2</sup>)

$g$  = acceleration of gravity, 32.17 ft/s<sup>2</sup> (9.807 m/s<sup>2</sup>)

$\Delta P$  = pressure drop, lb/ft<sup>2</sup> (N/m<sup>2</sup>)

$\gamma$  = specific weight (force) of liquid, lb/ft<sup>3</sup> (N/m<sup>3</sup>)

$A_r$  = percentage of open area

The resistance coefficient  $K_1$  and the orifice coefficient  $C$  may be interchanged in Eqs. 24 and 38 for loss through perforated plates:

$$C = \sqrt{\frac{1 - \left( \frac{A_r}{100} \right)^2}{K_1 - \left( \frac{A_r}{100} \right)^2}} \quad (39)$$

$$K_1 = \frac{1 - \left( \frac{A_r}{100} \right)^2}{C^2 \left( \frac{A_r}{100} \right)^2} \quad (40)$$

**TABLE 10** Orifice coefficients  $C$  for equilateral-triangle pitch perforated plates

Pitch/ $D_h$	$Re$	$l/D_h$								
		0.33	0.43	0.50	0.52	0.65	0.75	0.80	1.0	2.0
2.0	400–4000	0.74–0.69	0.75–0.71	0.76–0.74	—	0.79–0.85	0.82–0.86	0.83–0.87	0.84–0.89	0.77–0.92
2.0	4000–20,000	0.69	0.71	0.74	0.77	0.85	0.86	0.87	0.89	0.92
3.0	400–4000	0.70–0.67	0.72–0.68	0.73–0.72	—	0.75–0.81	0.76–0.82	0.77–0.84	0.78–0.85	0.70–0.87
3.0	4000–20,000	0.67	0.68	0.72	0.74	0.81	0.82	0.84	0.85	0.87
4.0	400–4000	0.71–0.66	0.72–0.67	0.72–0.69	—	0.73–0.77	0.74–0.79	0.75–0.81	0.76–0.53	0.69–0.84
4.0	4000–20,000	0.66	0.67	0.69	0.72	0.77	0.79	0.81	0.88	0.84
5.0	400–4000	0.68–0.65	0.69–0.66	0.7–0.68	—	0.72–0.76	0.73–0.77	0.74–0.78	0.75–0.81	0.65–0.82
5.0	4000–20,000	0.65	0.66	0.68	0.71	0.76	0.77	0.78	0.81	0.82

Note: Pitch/ $D_h$  = pitch-to-hole-diameter ratio;  $l/D_h$  = plate-thickness-to-hole diameter ratio;  $Re$  = Reynolds number

Source: References 10 and 11.

**Throttling Orifices** In addition to measuring flow, orifices can be used to (a) reduce flow by adding artificial resistance to increase system head, (b) dissipate energy to provide a desired pressure reduction, and (c) create a high-velocity jet. Orifices for these purposes are called *throttling orifices*. In order to maintain a desired minimum flow to prevent damage to a centrifugal pump, a throttling orifice, or a series of throttling orifices, can be used in the bypass system. The orifice provides additional bypass resistance to maintain the required bypass flow.

A throttling orifice can be fabricated by drilling a hole in a metal plate (or through bar stock) that, when inserted between flanges in a pipe (or threaded to pipe), will create the desired loss of head at the design flow. The resistance coefficient  $K_1$  may be calculated as if the throttling device were a single hole in a perforated plate, using Table 9 and Eqs. 30, 31, and 33, and the loss of head calculated using Eq. 24.

Energy is dissipated through a throttling orifice because pressure head is converted to velocity head and this conversion is followed by an inefficient pressure head recovery. Conditions may exist at the orifice *vena contracta* that could cause vaporization of the high-velocity, low-pressure liquid jet. Care must be taken in selecting the orifice size to avoid excessive cavitation noise or choke flow. An orifice cavitation index used to check the orifice selection is described by Tung and Mikasinovic,<sup>12</sup> who also discuss the use of orifices in series to avoid cavitation.

Although orifices are used to meter flow, accuracy requires that they be fabricated to standard proportions and that pressure taps be precisely located (Reference 6 and Figure 45). A distinction should be made between *meter differential pressure*, which is used to measure flow and is the difference in pressure at the upstream and downstream *vena contracta* taps, and *meter loss of head* calculated using the resistance coefficient  $K_1$ , which is the total overall loss of energy as measured at the upstream tap and past the downstream *vena contracta* tap. The loss of head through a standard orifice meter should be calculated as discussed previously under Meters.

**Water Meters and Backflow Preventors** Tables 11 and 12 from Reference 17 provide indicative values of losses through these devices.

## PUMP FLOW, HEAD, AND POWER IN VARYING TEMPERATURE SYSTEMS \_\_\_\_\_

In a pumping system where the weight of liquid pumped is constant, the volumetric flow rate will vary through system components having different temperatures. An example would be the condensate and feedwater system in a steam power plant. The following equation may be used to calculate volumetric flow rate using the specific gravity corresponding to the temperature of the liquid at the location in the system where flow is required:

$$\text{In USCS units} \quad \text{gpm} = \frac{\text{lb/h}}{500 (\text{sp. gr.})} \quad (41a)$$

$$\text{In SI units} \quad \text{m}^3/\text{h} = \frac{\text{kg/h}}{998 (\text{sp. gr.})} \quad (41b)$$

When calculating the total head required of a pump or pumps to overcome total system component losses, the actual volumetric flow rate and temperature through each component must be used because head loss is a function of velocity and viscosity. Information provided in this chapter permits computing pipe, valve, and fitting losses in  $\text{ft} \cdot \text{lb}/\text{lb}$  or  $\text{ft} (\text{N} \cdot \text{m}/\text{N}$  or  $\text{m})$  of liquid passing through the component. If the pump is at a location in the system where the temperature is different than at the locations where the head losses are calculated, the total head to be produced by the pump cannot be found by simply adding the individual component heads.

The pump head required to produce a specific increase in pressure varies inversely with specific gravity. Therefore, to calculate pump total head, either the component total



**TABLE 11** Pressure losses for turbine-type water meters

Flow Rate, gpm	Pressure Loss, psi, when Meter Size Is:						
	2 in	3 in	4 in	6 in	8 in	10 in	12 in
100	0.8	0.8	0.5				
150	3.5	3.5	1.5				
200	6.5	6.5	3.0				
250	10.0	10.0	4.5				
300		14.0	5.5				
350			7.0				
400			8.0	0.5			
450			9.0	1.0			
500			10.5	1.2	0.5	0.5	
600				2.0	1.0	0.6	
700				3.0	1.1	0.7	
800				4.0	1.4	0.8	
900				5.0	1.7	1.0	
1000				6.0	2.0	1.1	0.6
1500				13.0	4.5	2.0	1.0
2000					8.0	3.0	1.6
2500					13.0	4.0	3.0
3000						6.0	4.5
3500						8.5	6.0
4000						11.0	7.7
5000							11.0
6000							18.0

in  $\times$  25.4 mm      gpm  $\times$  .227 = m<sup>3</sup>/h      psi  $\times$  .069 = bar

SOURCE: Reference 17

heads must be converted to pump equivalent heads and added together, or all component losses must be expressed in pressure units so the total of these pressures can be converted to an equivalent pump head at the pump temperature. From Eqs. 2 and 3, the pump equivalent head is

$$h_2 = \frac{\gamma_1}{\gamma_2} h_1$$

or

$$h_2 = \frac{\text{sp. gr.}_1}{\text{sp. gr.}_2} h_1$$

where the subscript 1 denotes the component and the subscript 2 denotes the pump. From Eq. 6, individual component head losses can be converted to lb/ft<sup>2</sup> (N/m<sup>2</sup>) using

$$p_1 = h_1 \gamma_1$$

Table 12 Pressure losses for backflow preventers

Flow Rate, gpm	Pressure Loss, psi, when Preventer Size Is:					
	2 in	3 in	4 in	6 in	8 in	10 in
100	3.0					
150	5.5	1.5				
200		2.2	3.0			
300		4.0	2.0			
400			2.5	3.5		
500			3.0	2.5		
600			4.0	2.4	4.5	
700			5.0	2.6	3.6	
800				2.8	3.0	
900				3.0	2.8	
1000				3.3	2.5	4.0
1200				3.7	2.0	3.5
1400				4.3	2.0	2.9
1600				5.0	2.4	2.7
1800					2.6	2.6
2000					2.8	2.5
2500					3.5	2.5
3000						3.0
3500						3.6
4000						4.0
4500						5.0

in  $\times$  25.4 mm      gpm  $\times$  .227 = m<sup>3</sup>/h      psi  $\times$  .069 = bar

SOURCE: Reference 17

Also for Eq. 6,

$$TH = \frac{P_{\Delta}}{\gamma_2} = \frac{\sum p_1}{\gamma_2}$$

from which total component losses in lb/ft<sup>2</sup> (N/m<sup>2</sup>) can be converted to an equivalent total pump head in feet (meters) of liquid to be produced at the pumping temperature.

In a varying temperature system, the positive or negative static head required to raise or lower the liquid pumped is not simply a difference in elevation. A pump must produce pressure in a pipe to raise liquid; the pressure required is proportional to the specific weight (force) of the liquid. The static head required at the pump should be found by expressing the suction and discharge elevation heads  $Z$  as pressures at the pump suction and discharge connections (corrected to the reference datum plane, if it is not at the pump centerline elevation) and using actual specific weights (forces) along the pipe. This differential pressure, in lb/ft<sup>2</sup> (N/m<sup>2</sup>), is then converted to an equivalent static head using the specific weight (force) or specific gravity at the pump in the above appropriate equations.

When designing a pumping system, there may be several locations for placing a pump to produce a specified flow rate in lb/h (kg/h) and an increase in pressure in lb/ft<sup>2</sup> (N/m<sup>2</sup>). If the temperature of the liquid varies at the different pump locations being considered (for example, before or after a feedwater heater in a steam power plant), the pump total head in feet (meters) and the volumetric flow rate in gpm (m<sup>3</sup>/h) will vary. Although it is true

that pump power is proportional to the product of volumetric flow  $\times$  head  $\times$  specific gravity, higher pumping temperature (lower specific gravity) will nevertheless result in higher pumping power. For the same conditions of weight (or mass) flow and differential pressure, pump power varies inversely with specific gravity because of the following relationships:

$$\text{Pump power} \propto \text{volumetric flow} \times \text{total head} \times \text{sp. gr.}$$

$$\text{Volumetric flow} \propto \frac{\text{weight or mass flow}}{\text{sp. gr.}}$$

$$\text{Total head} \propto \frac{\text{pressure}}{\text{sp. gr.}}$$

therefore,

$$\text{Pump power} \propto \frac{\text{weight or mass flow}}{\text{sp. gr.}} \times \frac{\text{pressure}}{\text{sp. gr.}} \times \text{sp. gr.}$$

then,

$$\text{Pump power} \propto \frac{(\text{weight or mass flow}) \times \text{pressure}}{\text{sp. gr.}}$$

Following are formulas for calculating pump input power in brake horsepower or brake kilowatts:

$$\text{In USCS units} \quad \text{bhp} = \frac{\text{gpm} \times TH \times \text{sp. gr.}}{3960 \times \text{pump eff.}} \quad (42a)$$

$$= \frac{\text{lb/h} \times \text{lb/in}^2}{858,600 \times \text{pump eff.} \times \text{sp. gr.}} \quad (43a)$$

$$\text{In SI units} \quad \text{bkW} = \frac{\text{m}^3/\text{h} \times \text{m} \times \text{sp. gr.}}{367.7 \times \text{pump eff.}} \quad (42b)$$

$$= \frac{\text{kg/h} \times \text{kPa}}{3,593,000 \times \text{pump eff.} \times \text{sp. gr.}} \quad (43b)$$

## REFERENCES

1. Stepanoff, A. J. *Centrifugal and Axial Flow Pumps*. 2d ed. Wiley, New York, 1948.
2. Moors, J. A. "Criteria for the Development of Siphonic Action in Pumping Plant Discharge Lines." Paper presented at Hydraulic Division, ASCE Annual Convention, New York, October 1957.
3. Richards, R. T. "Air Binding in Water Pipelines." *AWWA. J.* 53, 1962.
4. "Flow of Fluids through Valves, Fittings, and Pipe." Technical Paper 410, 15th printing, Crane, New York, 1980.
5. Hydraulic Institute Engineering Data Book, 2nd Edition, 1990, Hydraulic Institute, Parsippany, NJ [www.pumps.org](http://www.pumps.org).
6. *Fluid Meters*. 6th ed. American Society of Mechanical Engineers, New York, 1971.
7. Idel'chik, I. E. *Handbook of Hydraulic Resistance*. (Translated from Russian.) Israel Program for Scientific Translations, Catalog No. 1505, 1966, available from U.S. Department of Commerce, Washington, D.C.
8. Padmanabhan, M., and Vigander, S. "Pressure Drop Due to Flow through Fine Mesh Screens." *ASCE J. Hydraulics Div.*, 1978, p. 1191.

9. Armour, J. C., and Cannon, J. N. "Fluid Flow Through Woven Screens." *AICHE J.* 14: 415, 1968.
10. Smith, P. L., Jr., and Van Winkle, M. "Discharge Coefficients through Perforated Plates at Reynolds Numbers of 400 to 3000." *AICHE J.* 4(3):266, 1958.
11. Kolodzie, P. A., Jr., and Van Winkle, M. "Discharge Coefficients Through Perforated Plates." *AICHE J.* 3(3):305, 1957.
12. Tung, P. C., and Mikasinovic, M. "Eliminating Cavitation from Pressure-Reducing Orifices." *Chem. Eng.*, December 1983, p. 69.
13. King, H. W., and Brater, E. *Handbook of Hydraulics*. 6th ed. McGraw-Hill, New York, 1976.
14. Streeter, V. L. *Fluid Mechanics*. 5th ed., McGraw-Hill, New York, 1971.
15. Davis, C. V., and Sorensen, K. E. *Handbook of Applied Hydraulics*. 3d ed. McGraw-Hill, New York, 1969.
16. U.S. Department of the Interior. *Bureau of Reclamation: Turbines and Pumps, Design Standard No. 6*, Washington, D.C., 1956.
17. Rishel, J. B. "Matching Pumps to System Requirements." *Plant Engineering*, December 1975, p. 125.

#### **FURTHER READING**

---

- Engineering Data Book*. 2nd ed. Hydraulic Institute, Parsippany, NJ, 1979.
- Flow Meter Engineering Handbook*. 4th ed. Minneapolis-Honeywell Regulator Company, Brown Instrument Division, Philadelphia, 1968.
- Karassik, I. J., and Garter, R. *Centrifugal Pumps*, McGraw-Hill, New York, 1960.
- McNown, J. S. "Mechanics of Manifold Flow." *Proc. Amer. Soc. Civil Eng.* 79(258), August 1953.
- Simpson, L. L. "Sizing Piping for Process Plants." *Chem. Eng.*, June 17, 1968, p. 192

---

# SECTION 8.2

---

# BRANCH-LINE PUMPING SYSTEMS

---

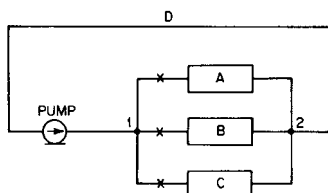
J. P. MESSINA

In some systems, the liquid leaving the pump or pumps will divide into a network of pipes. If the pump is of the centrifugal type, the total pump flow is dependent on the combined system resistance. The total pump flow and flow through each branch can be determined by the following methods. (Review “Pump Total Head and System-Head Curves” in Section 8.1.)

## **BRANCHES IN CLOSED-LOOP SYSTEMS**

---

Figure 1 illustrates a pump and network of piping consisting of three parallel branches in series with common supply and return headers. Junction points 1 and 2 need not be at the same elevation (provided the liquid density remains constant and the pipes flow full and free of vapor) because, in a closed-loop system, the net change in elevation is zero. Figure



**FIGURE 1** Closed loop pumping system with branch lines

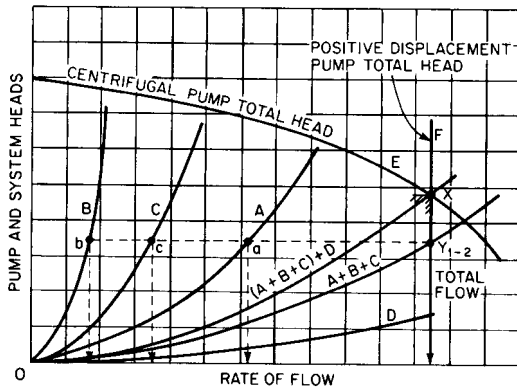


FIGURE 2 System-head curves for pump and branch lines shown in Figure 1 with all valves open

2 shows the system total-head curves for each branch line and header considered independent of the others. These curves are constructed for several flow rates by adding the frictional resistances of the pipes, fittings, and head losses through the equipment serviced from point 1 to point 2. Curves *A*, *B*, *C*, and *D* therefore represent the variation in system resistance in feet (meters) versus flow through each branch and header.

If the valves are open in all branches, the total system resistance, total pump flow, and individual branch flows are found by the following method. First observe that (a) the total flow must be equal to the sum of the branch flows, (b) the head loss or pressure drop across each branch from junction 1 to junction 2 is identical, and (c) the flow divides to produce these identical head losses. Therefore, at several head points, add together the flow through each branch and obtain curve  $A + B + C$ . Header *D* is in series with branches *A*, *B*, and *C*, and their system heads are added together for several flow conditions to obtain curve  $(A + B + C) + D$ . On curve *E*, the head-capacity characteristics of a centrifugal pump, point *X* represents the pump flow because at this point the system total head and pump total head are equal. Point  $Y_{1-2}$  represents the total head across points 1 and 2, and this head determines the flow through each branch; consequently points *a*, *b*, and *c* give individual branch flows. Curve *F* represents the head-capacity characteristics of a positive displacement pump (constant capacity) that would produce the same flow conditions.

If valve *A* is open and valves *B* and *C* are closed, Figure 3 shows the construction of the curves required to determine pump flow point *X'*. Obviously the pump flow and branch *A* flow are the same. Note that the total flow of point *X* is less than when all valves are open as a result of an increase in system head. If all valves were open and the total flow was obtained by a positive displacement pump having a constant capacity curve *F*, closing valves *B* and *C* would not change the flow. The system head would, however, increase to point *X''* and the head would be greater than for a centrifugal pump having curve *E*.

Also shown in Figure 3 are the system total-head curves for different combinations of open valves *A*, *B*, and *C* and the resulting flow caused by a pump having characteristic curve *E*. For these various valve combinations, the head differential across the junction points is found by subtracting the head of the curve *D* from the system total head for the condition investigated, for example, point  $Y'_{1-2}$  for only valve *A* open. The intersection of a horizontal line through point  $Y'_{1-2}$  and the individual branch curves gives the branch flow, as illustrated in Figure 2.

## BRANCHES IN OPEN-ENDED SYSTEMS

Figure 4 illustrates a pump supplying three branch lines that are open-ended and terminate at different elevations. Figure 5 shows the system total-head curves for each branch

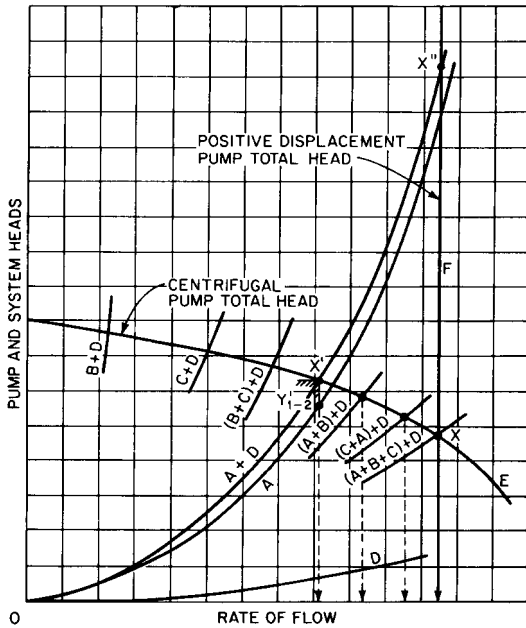


FIGURE 3 System-head curves for pump and branch line shown in Figure 1 with different combinations of open valves

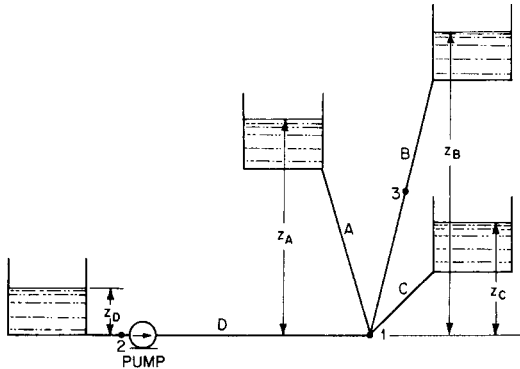


FIGURE 4 Open-ended pumping system with branch lines

line and main supply line considered independently of each other. These curves are constructed by starting at elevation heads  $Z_A$ ,  $Z_B$ ,  $Z_C$  and  $Z_D$  at zero flow. To each of these heads is added the frictional resistances in each line for several flow rates. Frictional losses from the suction tank to junction 1 are included in curve  $D$ . Curves  $A$ ,  $B$ ,  $C$ , and  $D$  therefore represent the variation in system resistance in feet (meters) versus flow through each branch and supply line. Note that  $Z_D$  is negative because in line  $D$  there is a decrease in elevation to point 1.

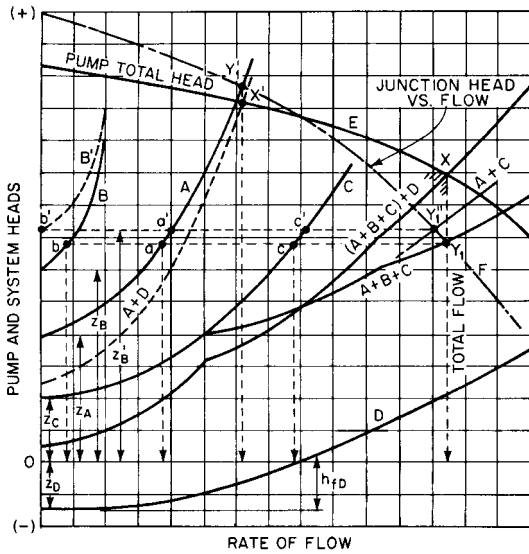


FIGURE 5 System-head curves for pump and branch lines shown in Figure 4

The total head at the junction is the head  $Z_D$  in the suction tank measured above point 1 plus the pump total head less the frictional head loss  $h_{fD}$  in line  $D$ , and it varies with flow, as illustrated by curve  $F$ .

The total system resistance, total pump flow, and individual branch flows are found by the following method. First observe that (a) the total flow must be equal to the sum of the branch flows, (b) the frictional resistance plus the elevation head measured relative junction 1 for each branch is identical and (c) the flow divides to produce these identical total branch heads. Therefore, at several head points, add together the flow of each branch to obtain curve  $A + B + C$ . Supply line  $D$  is in series with branches  $A$ ,  $B$ , and  $C$ , and their system heads are added algebraically for several flow conditions to obtain curve  $(A + B + C) + D$ . If curve  $E$  is the head-capacity characteristics of a centrifugal pump, point  $X$  represents the pump flow because at this point the system total head and pump total head are equal. Point  $Y_1$  represents the total head at junction 1, and this head determines the flow through each branch; consequently points  $a$ ,  $b$ , and  $c$  give individual branch flows.

In this example the pump discharges to all tanks, but this should not be assumed. There is a limiting liquid level elevation for each tank, and, if this level is exceeded, flow will be from the tank into the junction. Therefore it is possible for the lower-level tanks to be fed by the higher-level tank and the pump. The limit for the liquid elevation in tank  $B$  is  $Z'_B$ , and it is found from the intersection of curve  $A + C$  with curve  $F$ , point  $Y'_1$ . The flow in branches  $A$  and  $C$  is at rates  $a'$  and  $c'$  when there is no flow in branch  $B$ . This is also a condition similar to closing a valve in branch  $B$ .

If elevation  $Z_B$  is greater than previously found limiting height  $Z'_B$  flow in branches  $A$  and  $C$  is determined in the following manner. Construct a curve for junction head versus flow by adding heads and flows that result when the pump and suction tank are in a series with each other and tank  $B$  (less line losses) is in parallel with the pump and suction tank. The intersection of this curve with curve  $A + C$  will give the junction head required to determine the individual flows from the pump and tank and the flows to tanks  $A$  and  $C$  (not illustrated).

If flow to branches  $B$  and  $C$  is shut off, Figure 5 illustrates the construction of the curves required to determine the pump flow point  $X'$  and junction head point  $Y'_1$ .



## CENTRIFUGAL PUMP BYPASS

Bypass orifices around centrifugal pumps are often used to maintain a minimum flow recommended by the pump manufacturer because of one or more of the following reasons:

- To limit the temperature rise to prevent seizing and cavitation
- To reduce shaft and bearing loads
- To prevent excessive recirculation in the impeller and casing
- To prevent overloading of driver if pump power increases with decrease in flow

Figure 6 illustrates a system that under certain conditions reduces pump flow below the recommended minimum. The pump delivers its flow to either tank A or tank B. Figure 7 shows the separate system-head curves for flow to tank A and for flow to tank B. Curve E is the head-capacity characteristics of the centrifugal pump. Individual flow rates to each tank are shown as  $Q_A$  and  $Q_B$ . The recommended minimum flow is  $Q_R$ , which is greater than  $Q_B$  by the amount shown. In order to maintain the minimum flow, a bypass orifice with necessary pipe, valves, and fittings is required to pass flow  $Q_C$  at total head  $H_R$  is when the pump discharges to tank B only.

Figure 8, (curve C) shows the construction necessary to determine the required bypass head versus flow characteristics of the orifice and pipe. The bypass system-head curve C includes the pipe, valve, and fitting losses from the pump connection between the suction tank and the end of the bypass piping below the suction water level. These losses must be deducted from the total bypass losses to determine the required orifice head.

Figure 9 illustrates the resultant pump flow with the bypass in operation. Curve C is added to curve B to obtain curve B + C by combining flows through each system at the same heads. Note that flow through the piping from the suction tank to junction 1 is the

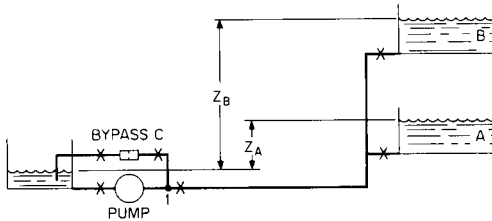


FIGURE 6 Pump with bypass to maintain minimum flow

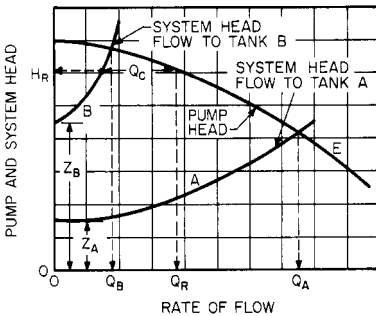


FIGURE 7 System-head curves for pump and tanks shown in Figure 6 with bypass valve closed

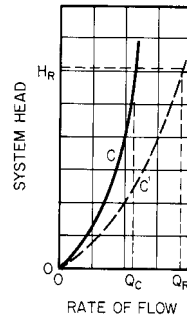


FIGURE 8 Bypass orifice system requirements

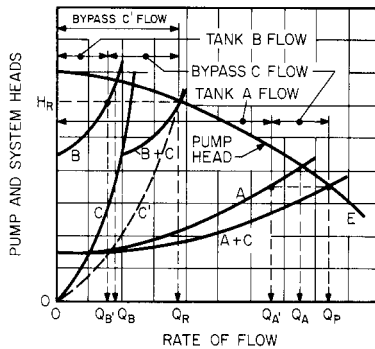


FIGURE 9 System-head curves for pump and tanks shown in Figure 6 with bypass valve open

total from both systems. Therefore, the combined system-head curve  $B + C$  should take this into consideration. Similarly, curve  $C$  is added to curve  $A$  to obtain curve  $A + C$ . Note that when the flow is directed to tank  $B$  with the bypass open, pump flow is increased from  $Q_B$  to  $Q_R$  and tank flow is decreased from  $Q_B$  to  $Q'_B$ . When the flow is directed to tank  $A$  with the bypass open, pump flow is increased from  $Q_A$  to  $Q_P$  and tank flow is decreased from  $Q_A$  to  $Q'_A$ .

If it is desired that there be no reduction in flow or that there be no waste of pumping power when flow is to tank  $A$ , the bypass can be closed either manually or automatically. If pump flow is monitored, this measurement can be used to open, close, or modulate the bypass valve automatically to maintain desired flow. Refer to Subsection 2.3.4 for more detailed information.

If operating procedures require that the pump occasionally be run with a closed valve (at the pump discharge or at tanks  $A$  and  $B$ ), the bypass line must be designed to recirculate all of the minimum required pump flow  $Q_R$ , dissipating head  $H_R$ , shown as curve  $C'$  and Figures 8 and 9.

## FLOW CONTROL THROUGH BRANCHES

The flow through branches  $A$ ,  $B$ , and  $C$  in Figures 1 and 4 is dependent on the individual branch characteristics. When parallel branches are connected to a pump, the resulting division of flow may not satisfy the requirements of the individual lines. If it is desired that the flow to each branch meet or exceed specified individual line requirements, it is necessary only to select a pump to provide the maximum head required by any one branch. In those branches where this head is more than required, the flow will be greater than the desired amount. A throttling valve or other flow-restricting device may be used to reduce the flow in these branches to the desired quantity. If the flow is controlled in this manner, the pump need be selected to produce only the minimum total system flow at a total head required to satisfy the branch needing the highest head at junction 1 in Figures 1 and 4.

The flow through a branch is sometimes dictated by the requirement of a component elsewhere in the system. For example, in the system shown in Figure 10, the required flow through component  $V$  could be greater than the sum of the required flows through components  $A$ ,  $B$ , and  $C$ . An additional branch line and control valve  $F$  around components  $A$ ,  $B$ , and  $C$  may be used to bypass the additional flow needed by component  $D$ . Individual component throttling valves may also be used, if needed, to adjust the flow in each branch.

The following example illustrates how flow through branches may be controlled and how pump total head is calculated.

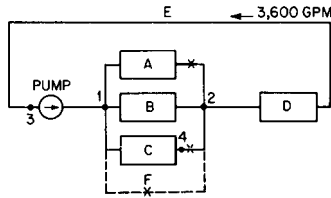


FIGURE 10 Example of a branch-flow pumping system

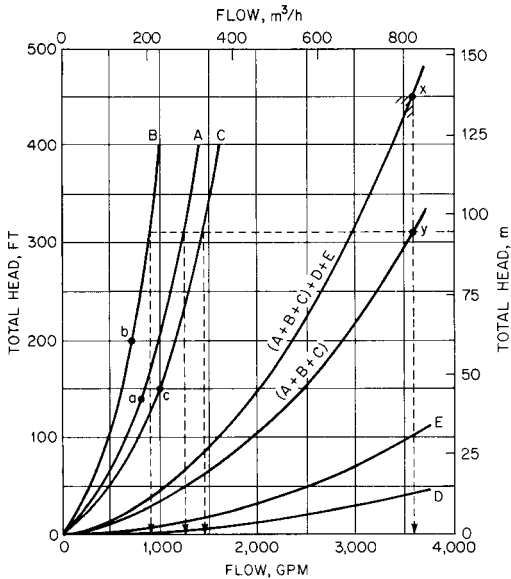


FIGURE 11 System-head curves required for solutions to example problems

**EXAMPLE** A pump is required to circulate water at a rate of 3600 gpm (817 m<sup>3</sup>/h) through the system shown in Figure 10. The head versus flow characteristics of the system components *A*, *B*, *C*, *D*, and *E* (system pipe and fittings) are shown in Figure 11. The branch pipe and fitting losses from point 1 to point 2 are included in the total heads for components *A*, *B*, and *C*. Determine

1. The pump total head required and the individual flows through components *A*, *B*, and *C*
2. The pump total head required if the flow through components *A*, *B*, and *C* need be only 800, 700, and 1000 gpm (182, 159, and 227 m<sup>3</sup>/h), respectively, and a bypass *F* is installed

Calculate the individual throttling valve head drops to achieve a controlled branch flow system.

#### Solution

1. Head versus flow curves *A*, *B*, and *C* of Figure 11 are added together in parallel, giving curve  $(A + B + C)$ . Curves  $(A + B + C)$ , *D*, and *E* are added together in

series, resulting in curve  $(A + B + C) + E + E$ . This latter curve indicates that 450 ft (137 m) total pump head is required at 3600 gpm (817 m<sup>3</sup>/h), point *X*. Curve  $(A + B + C)$  crosses point *Y* at 3600 gpm (817 m<sup>3</sup>/h) flow through the branches, and this condition requires 310 ft (94.5 m) total head, which is the head across branch points 1 and 2. From each individual component curve, the flow through branches *A*, *B*, and *C* can be read as 1250, 900, and 1450 gpm (284, 204, and 329 m<sup>3</sup>/h), respectively.

- Because the total flow through components *A*, *B*, and *C* need be only 2500 gpm  $(800 + 700 + 1000)$  [568 m<sup>3</sup>/h  $(182 + 159 + 227)$ ], the bypass should be designed to pass 1100 gpm (249 m<sup>3</sup>/h). Component *B* requires the maximum head, 200 ft (61 m) differential (point *b*) across points 1 and 2. Throttling valves are needed in components *A* and *C* and bypass *F* to increase the head in each branch to 200 ft (61 m) at the required flows. Branch *A* (point *a*) requires only 140 ft (42.7 m) total head to pass 800 gpm (182 m<sup>3</sup>/h); therefore the throttling valve must be designed for a 60-ft (42.7-m) head loss. Branch *C* (point *c*) requires only 150 ft (45.7 m) total head to pass 1000 gpm (227 m<sup>3</sup>/h), requiring a throttling valve for a 50-ft (15.3-m) head loss. The bypass control valve and piping should be designed to produce a 200-ft (61-m) head drop at 1100 gpm (249 m<sup>3</sup>/h).

At 3600 gpm (817 m<sup>3</sup>/h), the pump is now required to overcome 200 ft (61 m) total head across points 1 and 2, 40 ft (12.2 m) total head through component *D*, and 100 ft (30.1 m) total head through the system pipe and fittings, component *E*, for a total of 340 ft (103.3 m). The reduction in pumping head from 450 to 340 ft (137.1 to 103.6 m), a saving of 110 ft (33.5 m), or 24.4% water power, is the result of decreasing the branch head from 310 to 200 ft (94.5 to 61 m) by bypassing the excess flow.

## PUMP TOTAL HEAD IN BRANCH-LINE SYSTEMS

---

The total head produced is the difference in total heads measured across the suction and discharge connections of a pump. As explained in Section 8.1, the total head is also the difference between the heads at any two points in the pumping system, one on each side of the pump, plus the sum of the head losses between these two points. Confusion sometimes results when the flow through the pump divides into branches in either closed-loop or open-ended systems. The points of head measurement can be in any branch line, upstream or downstream from the pump, regardless of the flow rate in these lines.

In part 2 of the previous example, the pump or system total head could be measured using points 3 and 4 in Figure 10. If the total head measured at the pump suction, point 3, were 25 ft (7.62 m) gage, the head measured at point 4 would be 205 ft (62.48 m) gage above the same reference datum plane, assuming 10 ft (3.05 m) of friction between the pump discharge and point 1. The difference between the head at point 3 and that at point 4 is 180 ft (54.86 m). The loss of head due to friction and the head drop through component *C* is  $10 + 150 = 160$  ft  $(3.05 + 47.5 = 48.75$  m). The pump and system total head at 3600 gpm (817 m<sup>3</sup>/h) is therefore  $180 + 160 = 340$  ft  $(54.86 + 48.75 = 103.63$  m).

Similarly, the pump and system total head for an open-ended system, such as the one shown in Figure 4, could be found by measuring, for example, the difference between the head at point 2 and that at point 3. Each head measurement would be referred to a common datum plane. The total head loss from 2 to 1 plus the head loss from 1 to 3, at the rate of flow in their respective lines, added to the difference between the head at 2 and that at 3, is the pump and system total head.

---

# SECTION 8.3

---

# WATERHAMMER

---

JOHN PARMAKIAN

Waterhammer is a very destructive force that exists in any pumping installation where the rate of flow changes abruptly for various reasons. Most engineers recognize the existence of waterhammer, but few realize its destructive force. Much time and expense have been spent repairing pipelines and pumps damaged by waterhammer. It is thus essential for an engineer to be able to know when to expect waterhammer, how to estimate the possible maximum pressure rise, and, if possible, how to provide means to reduce the maximum pressure rise to a safe limit.

The computational procedures used for the analysis of waterhammer in pump discharge lines with electric-motor-driven pumps have been known for many years, beginning with the basic waterhammer contributions by Joukousky and Allievi. This work was followed in later years by many applications of numeric, graphic, and computer techniques. Although the theory and mechanics of computing waterhammer in pump discharge lines have advanced rapidly in recent years, there are many practical aspects of this subject that are still confusing to engineers. It is the purpose of this section to bring these to the reader's attention. The first and major portion of the section contains a discussion of some practical aspects of waterhammer control devices used in pumping plants; the second indicates the source of various charts that provide ready waterhammer solutions for a variety of these control devices.

## **NOMENCLATURE**

---

The following is a list of variables commonly used in waterhammer computations. The SI conversion factors for these terms are to be found in Table 1.

$a$  = velocity of pressure wave, ft/s

$D$  = inside diameter of conduit, ft

**TABLE 1** SI conversions

To convert	To	Multiply by
$GD^2$ ( $\text{kg} \cdot \text{m}^2$ )	$WR^2$ ( $\text{lb} \cdot \text{ft}^2$ )	23.73
$\text{kg}/\text{m}^2$	$\text{lb}/\text{ft}^2$	0.2048
$\text{kg}/\text{m}^3$	$\text{lb}/\text{ft}^3$	0.06243
m	ft	3.281
m/s	ft/s	3.281
$\text{m}/\text{s}^2$	$\text{ft}/\text{s}^2$	3.281
$\text{m}^3/\text{s}$	$\text{ft}^3/\text{s}$	35.32
mm	ft	$3.281 \times 10^{-3}$

- $e$  = thickness of pipe wall, ft  
 $E$  = Young's modulus for pipe material,  $\text{lb}/\text{ft}^2$   
 $g$  = acceleration of gravity,  $\text{ft}/\text{s}^2$   
 $H_o$  = pumping head for initial steady pumping conditions, ft  
 $H_R$  = rated pumping head, ft  
 $K_1 = 91,600 H_R Q_R / WR^2 N_R^2 S^{-1}$   
 $K$  = volume modulus of liquid,  $\text{lb}/\text{ft}^2$   
 $L$  = total length of conduit, ft  
 $2L/a$  = round-trip wave travel time, s  
 $N_R$  = rated pump speed, rpm  
 $\eta_R$  = pump efficiency at rated speed and head, decimal form  
 $\rho$  = pipe line constant =  $a \bar{V}_o / g H_o$   
 $Q_o$  = initial flow through pump,  $\text{ft}^3/\text{s}$   
 $Q_R$  = rated flow through pump,  $\text{ft}^3/\text{s}$   
 $\mu$  = Poisson's ratio of pipe material  
 $V_o$  = velocity in conduit for initial steady conditions,  $\text{ft}/\text{s}$   
 $w$  = specific weight of water,  $\text{lb}/\text{ft}^3$   
 $WR^2$  = flywheel effect of rotating parts of motor, pump, and entrained water,  $\text{lb}\text{-ft}^2$

## BASIC ASSUMPTIONS

A considerable number of assumptions were made in the derivation of the fundamental water-hammer equations and in the solution of the various hydraulic transients in pumping systems. These assumptions are often overlooked and involve the physical properties of the fluid and pipeline, the kinematics of the flow, and the transient response of the pump as follows:

1. The fluid in the pipe system is elastic, of homogeneous density, and always in the liquid state.
2. The pipe wall material or conduit is homogeneous, isotropic, and elastic.
3. The velocities and pressures in the pipeline, which is always flowing full, are uniformly distributed over any transverse cross-section of the pipe.
4. The velocity head in the pipeline is negligible relative to the pressure changes.

5. At any time during the pump transient, when operation is in the zones of pump operation, energy dissipation, and turbine operation, there is an instantaneous agreement at the pump, as defined by the steady-state complete pump characteristics of the pump speed and torque corresponding to the transient head and flow that exist at that moment at the pump.
6. The length between the inlet and outlet of the pump is so short that waterhammer waves propagate between these two points instantly.
7. Windage effects of the rotating elements of the pump and motor during the transients are negligible.
8. Water levels at the intake and discharge reservoirs do not change during the transient period.

## FACTORS AFFECTING WATERHAMMER

---

**High- and Low-Head Pumping Systems** Waterhammer is of greater significance in low-head pumping systems than in high-head systems. The normal steady water velocities in high-head and low-head pumping systems are usually of about the same order of magnitude. However, the pressure changes are proportional to the rate of change in the velocity of the water in the line. For a given rate of velocity change, however, the pressure changes in the high- and low-head pumping systems are of about the same order of magnitude. Therefore, a given head rise would be a larger proportion of the pumping head in a low-head pumping system than a high-head system.

**Discharge Line Profile** The pump discharge line profile is usually based on economic, topographic, and land right-of-way considerations. However, in selecting the alignment along which a pump discharge line is to be located, there are other considerations that often make one pipeline profile and alignment more favorable than another. For example, upon a power failure at the pump motors, the envelope of the maximum downsurge gradient along the length of the pipeline is a concave curve. Therefore it may be possible to avoid the use of expensive pressure control devices at a pumping plant if the pipeline profile is also concave and is not located above the downsurge gradient curve. In some cases, it may even be economical to lower the profile of the discharge line at the critical locations by deeper excavation. If a surge tank at the pumping plant is definitely required, the most favorable pipeline profile is one with high ground near the pumping plant where the surge tank structure can be placed so its height above the natural ground line will be much less than what would be necessary if there were no high ground near the plant.

**Rigid Water Column Theory** The question is often raised as to whether the rigid water column theory is sufficiently accurate for the computation of waterhammer in pump discharge lines. In the rigid water column theory, the water is assumed to be incompressible and the pipe walls rigid. In the author's experience, the accuracy and limitations of the rigid water column theory are often questionable for most waterhammer problems that occur in pump discharge lines.

**Waterhammer Wave Velocity** From a practical viewpoint, a difference of 15 to 20% in the magnitude of the computed waterhammer wave velocity usually has very little effect on the waterhammer in pump discharge lines. The effect on the waterhammer due to a possible error in the wave velocity can be verified by first computing the wave velocity as accurately as possible and then recomputing the transients for the critical cases with a wave velocity about 20% higher or lower. At installations where alternative materials for the pipeline are being investigated, one waterhammer wave velocity and solution for waterhammer for either alternative will usually suffice regardless of the pipe material finally selected.

**Pipeline Size** The diameter of the pipeline is usually determined from economic consideration based on steady-state pumping conditions. However, the waterhammer effects in a pump discharge line can be reduced by increasing the size of the discharge line because the velocity changes in the larger pipeline will be less. This is usually an expensive method of reducing waterhammer in pump discharge lines, but there are sometimes occasions where an increase in pipe size may be justified to avoid the use of more expensive waterhammer control devices.

**Number of Pumps** The number of pumps connected to each pump discharge line is usually determined from the operational requirements of the installation, availability of pumps, and other economic considerations. However, the number and size of pumps connected to each discharge line have some effect on the waterhammer transients. For pump start-up with pumps equipped with check valves, the greater the number of pumps on each discharge line, the smaller the pressure rise. Moreover, if there is a malfunction at one of the pumps or check valves, a multiple pump installation on each discharge line would be preferable to a single pump installation because the flow changes in the discharge line due to such a malfunction would be less with multiple pumps. When a simultaneous power failure occurs at all of the pump motors, the fewer the number of pumps on a discharge line, the smaller the pressure changes and other hydraulic transients. For a given total flow in the discharge line, a large number of small pumps and motors will have considerably less total kinetic energy in the rotating parts to sustain the flow than a small number of pumps. Consequently, for the same total flow, the velocity changes and waterhammer effects due to a power failure are a minimum when there is only one pump connected to each discharge line.

**Flywheel Effect ( $WR^2$ )** Another method for reducing the waterhammer effects in pump discharge lines is to provide additional flywheel effect ( $WR^2$ ) in the rotating element of the motor. As an average, the motor usually provides about 90% of the combined flywheel effect of the rotating elements of the pump and motor. Upon a power failure at the motor, an increase in the kinetic energy of the rotating parts will reduce the rate of change in the flow of water in the discharge line. In most cases, an increase of 100% in the  $WR^2$  of large motors can usually be obtained at an increased cost of about 20% of the original cost of the motor. Ordinarily, an increase in  $WR^2$  is not an economical method for reducing waterhammer, but it is possible in some marginal cases to eliminate other, more expensive pressure control devices.

**Specific Speed of Pumps** For a given pipeline and initial steady-flow conditions, the maximum head rise that can occur in a discharge line subsequent to a power failure where the reverse flow passes through the pump depends first on the magnitude of the maximum reverse flow that can pass through the pump during the energy-dissipation and turbine-operation zones. Secondly, it depends on the flow that can pass through the pump at runaway speed in reverse. Upon a power failure, the radial-flow (low-specific-speed) pump will produce slightly more downsurge than the axial-flow (high-specific-speed) and mixed-flow pumps.<sup>1</sup> The radial-flow pump will also produce the highest head rise upon a power failure if the reverse flow is permitted to pass through the pump. There is usually very little head rise at mixed-flow and axial-flow pumps when a power failure occurs and if a water column separation does not occur at some other location in the line.

During a power failure with no valves, the highest reverse speed is reached by the axial-flow pump and the lowest by the radial-flow pump. Care must therefore be taken to prevent damage to the motors with the higher-specific-speed pumps because of these higher reverse speeds. Upon pump start-up against an initially closed check valve, the axial-flow pump will produce the highest head rise in the discharge line because it also has the highest shutoff head. On pump start-up, a radial-flow pump will produce a nominal head rise, but an axial-flow pump can produce a head rise of several times the static head.

**Complete Pump Characteristics** In order to determine the transient conditions due to a power failure at the pump motors, the waterhammer wave phenomena in the pipeline, the rotating inertia of the pump and motor, and the complete pump characteristics as well



as other boundary conditions and head losses must be known. In the solution of waterhammer problems with computers, the complete pump characteristics are sometimes approximated by polynomial expressions in which the coefficients of the polynomial are obtained by fitting a representative curve through several points at specific locations on the pump characteristics diagram. Pump manufacturers sometimes provide limited information to determine such coefficients. However, a comparison between the polynomial values and the complete pump characteristics diagram indicates serious discrepancies in some cases, especially in the zone of energy dissipation. To ensure that a serious error does not result in the computation of the hydraulic transients, care must be exercised in the use of an approximate polynomial expression as a substitute for the correct complete pump characteristics.

**Complex Piping Systems** As noted previously in the basic assumptions, the waterhammer theory is strictly applicable for a pipeline of uniform characteristics. However, for waterhammer purposes, a complex piping system can be reduced to a satisfactory equivalent uniform pipe system. The approximations are made by neglecting the wave transmission effects at the junctions and points of discontinuity and by utilizing the rigid water column theory. The pertinent water-hammer equations are then found to be analogous to those used in electric circuits. In practice, the waterhammer analysis with these approximations will usually give more conservative results than those obtained experimentally from the pipe system.<sup>2</sup>

**Available Waterhammer Solutions** The waterhammer solutions for pumping systems with various surge control devices are given in convenient chart form in the references. These include the following:

1. Hydraulic transients at the pump and midlength of the pump discharge lines for radial-flow, mixed-flow, and axial-flow pumps with reverse flow passing through the pumps
2. Surge tanks
3. Air chambers
4. Surge suppressors
5. One-way surge tanks
6. Water column separation

The operation of these surge control devices is described next.

### **Power Failure at Pump Motors**

**PUMPS WITH NO VALVES AT THE PUMP** When the power supply to the pump motors is suddenly cut off, the only energy that is left to drive the pump in the forward direction is the kinetic energy of the rotating elements of the pump and motor. Because this energy is usually relatively small relative to that required to maintain the flow of water against the discharge head, the reduction in the pump speed is very rapid. As the pump speed is reduced, the flow of water in the discharge line is also reduced. As a result of these rapid flow changes, waterhammer waves of increasing subnormal pressure are formed in the discharge line at the pump. These subnormal pressure waves move rapidly up the discharge line to the discharge outlet, where complete wave reflections occur. Soon the speed of the pump is reduced to a point where no water can be delivered against the existing head. If there is no control valve at the pump, the flow through the pump reverses even though the pump may still be rotating in the forward direction. The speed of the pump now drops more rapidly and passes through zero speed. Soon the maximum reverse flow passes through the pump. A short time later the pump, acting as a turbine, reaches runaway speed in reverse. As the pump approaches runaway speed, the reverse flow through the pump is reduced. For radial-flow pumps, this rapid reduction in reverse flow produces a pressure rise at the pump and along the length of the discharge line. The results of a large number of waterhammer solutions for a given set of radial-flow (low-specific-speed)

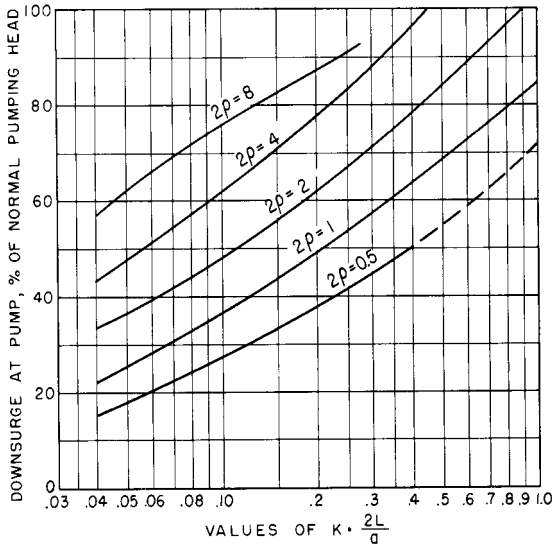


FIGURE 1 Downsurge at pump

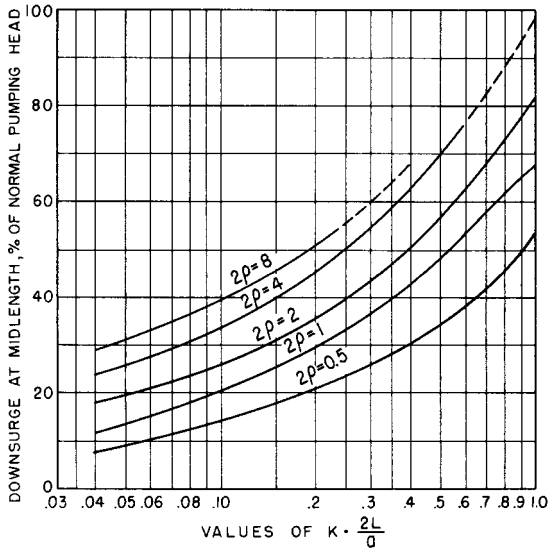


FIGURE 2 Downsurge at midlength

pump characteristics are given in chart form in Figures 1 to 8. These charts furnish a convenient method for obtaining the hydraulic transients at the pump and midlength of the discharge line when no control valves are present at the pump. Although the charts are theoretically applicable to one particular set of radial-flow pump characteristics, they are

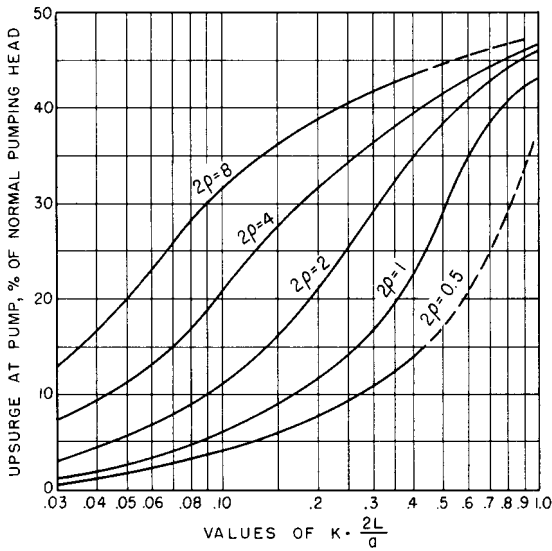


FIGURE 3 Upsurge at pump

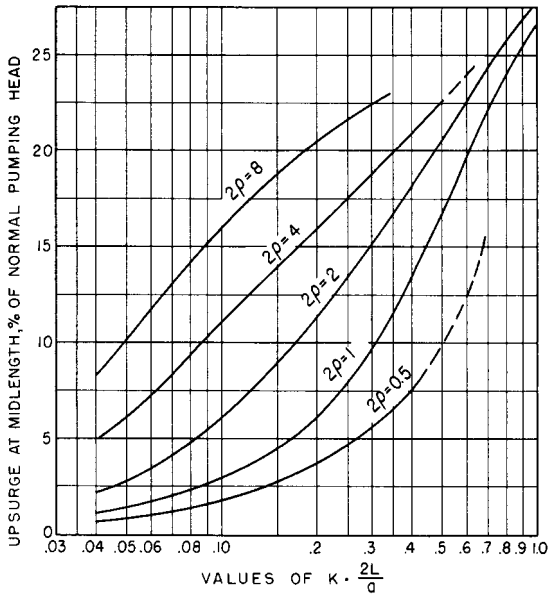


FIGURE 4 Upsurge at midlength

useful for estimating the waterhammer effects in any pump discharge line equipped with radial-flow pumps. The charts are based on two independent parameters:  $\rho$ , the pipeline constant, and  $K(2L/a)$ , a constant that includes the effect of pump and motor inertia and

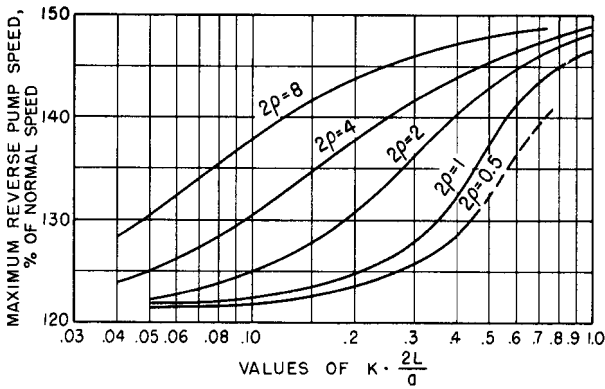


FIGURE 5 Maximum reverse speed

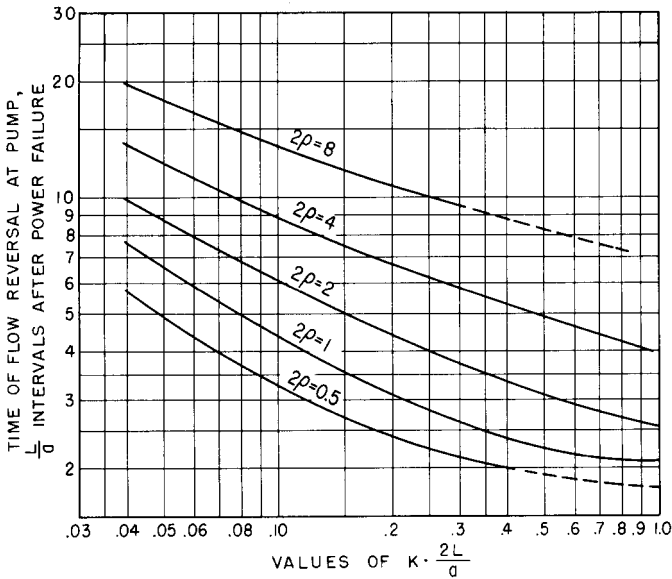


FIGURE 6 Time of flow reversal at pump

the waterhammer wave travel time of the discharge line. If the frictional head in the discharge line during normal operation is more than 25% of the total pumping head and if water column separation does not occur at any point in the line, the maximum head at the pump with reverse flow passing through the pumps will usually not exceed the initial pumping head.<sup>3</sup>

**PUMPS EQUIPPED WITH CHECK VALVES** There are a number of problems associated with the use of check valves in pump discharge lines. Under steady flow conditions, the pump discharge keeps the check valve open. However, when the flow through the pump reverses subsequent to a power failure, the check valve closes very rapidly under the action of the

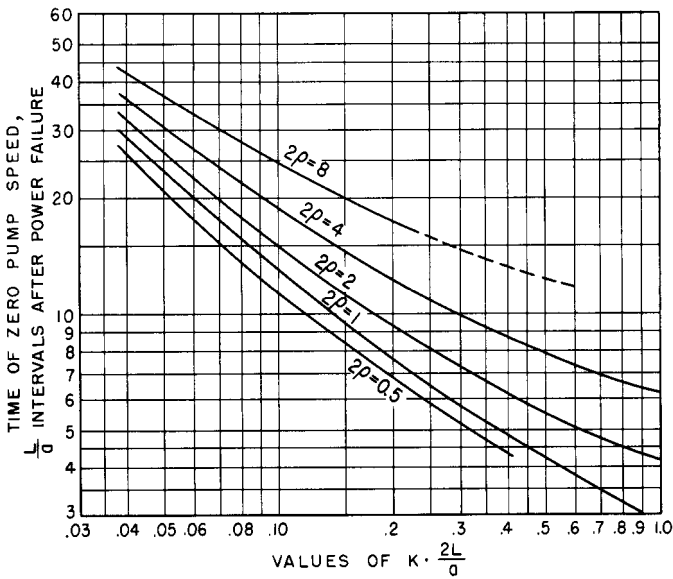


FIGURE 7 Time of zero pump speed

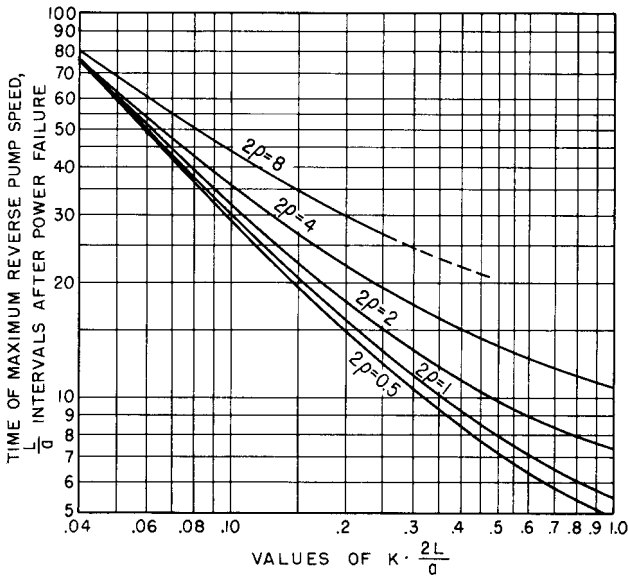


FIGURE 8 Time of maximum reverse pump speed

reverse flow and the resulting dynamic forces on the check valve disk. Under these conditions, neglecting pipeline friction, the head rise in the discharge line at the check valve is about equal to the head drop that existed at the moment of flow reversal. However, if

the check valve closure upon flow reversal is momentarily delayed because of hinge friction, malfunction, or the inertial characteristics of the valve, the maximum head rise in the discharge line at the check valve can be considerably higher. On the other hand, if the check valve closure can be accomplished slightly in advance of flow reversal, the head rise in the pump discharge line at the valve is even lower than that obtained with a check valve that closes at the moment of flow reversal. This feature is utilized by a number of check valve manufacturers, who provide spring-loaded or lever-arm-weighted devices on the check valve hinge pins to assist in closing the valve disk before the flow reverses. With these devices, the hydraulic forces on the valve disk under normal flow conditions must be sufficient to overcome the spring or lever-arm-weight forces in order to keep the check valve disk wide open so the head losses at the valve under steady flow conditions will be a minimum.

Check valves in pump discharge lines may be grouped into two general classes, rapid-closing and slow-closing. From the previous considerations noted, the primary requirement for a check valve upon a power failure is that it should close quickly, before a substantial reverse flow has been established. When this primary requirement for a fast-closing check valve cannot be met because of the flow characteristics of the system and the design of the check valve, an alternative is to provide a device such as a dashpot, which will slow down or cushion the last portion of the check valve closure. This feature has been utilized by a number of check valve manufacturers.

**CONTROLLED VALVE CLOSURE** At most large pumping plant installations, the use of a single-speed discharge valve closure subsequent to a power failure will usually limit the head rise in the discharge line to an acceptable value. However, it will be found that with the optimum single-speed closure, some reverse rotation below the maximum runaway speed of the unit in reverse will occur. If it is desired from other considerations to prevent or to limit the reverse speed of the unit, a two-speed valve closure can be used. In such cases, the discharge valve should close the major portion of its stroke very rapidly up to the moment that the flow reverses at the pump. It should then complete the remainder of its stroke at a lower rate in order to limit the pressure rise in the discharge line to an acceptable value. At pumping plants where there is more than one pump on the same discharge line, a compromise must be obtained on the optimum single-speed and two-speed closure rates for the various combination of pumps that might be in operation at the time of a power failure.

**SURGE SUPPRESSORS** Surge suppressors are sometimes used in pumping plants to control the pressure rise that occurs in pump discharge lines subsequent to power interruptions. A typical surge suppressor consists of a pilot-operated valve that opens quickly after a power interruption either through the loss of power to a solenoid or by a sudden large pressure reduction or pressure increase at the surge suppressor. This valve provides an opening for releasing water from the pump discharge line. The valve is later closed at a lower rate by the action of a dashpot to control the pressure rise as the flow of water is shut off. A properly sized and field-adjusted surge suppressor can reduce the pressure rise in the discharge line to any desired value, provided that water column separation does not occur at other locations in the discharge line. The charts given in Reference 4 can be used to determine the required flow capacity of the surge suppressor.

The proper field adjustment of a surge suppressor is very important. If the suppressor opens too rapidly subsequent to a power failure, the downsurge at the pump and along the discharge line profile will be more than if no surge suppressor is present. As a result, a water column separation may be produced at some locations in the discharge line by the premature opening of the surge suppressor. If the suppressor closes too rapidly after the maximum reverse flow has been established, a large pressure rise will occur.

**WATER COLUMN SEPARATION** Water column separation in a pump discharge line subsequent to a power failure at the pump motors occurs whenever the momentary hydraulic gradient at any location reduces the pressure in the discharge line to the vapor pressure of water. Whenever this condition occurs, the normal waterhammer solution is no longer valid. If the subatmospheric pressure condition inside the pipe persists for a sufficient

period, the water in the discharge line parts and is separated by a section of water and vapor. Whenever possible, water column separation should be avoided because of the potentially high pressure rise that often results when the two water columns rejoin. An approximate waterhammer solution for water column separation in pump discharge lines is given in Reference 5.

**QUICK-OPENING, SLOW-CLOSING VALVES** A quick-opening, dashpot-controlled, slow-closing valve can be used to limit the pressure rise at the high points in the discharge line, where water column separation frequently occurs. When the pressure in the pipeline at the point of water column separation drops below a predetermined value for which the valve is set, the valve opens quickly and a small amount of air is admitted in the pipeline. After the upper water column in the pipeline stops, reverses, and returns to the point of separation near the valve, the valve should be wide open. The air and water mixes and then the clear water discharges through the valve. The open valve then provides a point of relief to reduce the pressure rise caused by the rejoining of the water columns. The valve is later closed slowly under the action of a dashpot so the head rise that occurs in the discharge line at the valve location when the reverse flow is shut off is not objectionable. Whenever these valves are used, precautions should be taken to ensure that they are properly sized, field-adjusted to the proper opening and closing times, and adequately protected against freezing.

**One-Way Surge Tanks** The one-way surge tank, which was introduced by the writer<sup>6</sup> is an effective and economical pressure control device for use at locations where water column separation occurs. A one-way surge tank is a relatively small tank filled with water to a level far below the hydraulic gradient. It is connected to the main pipeline with check valves that are held closed by the discharge line pressure. Upon a power failure, when the pressure in the discharge line at the one-way surge tank drops below the head corresponding to the water level in the tank, the check valve opens quickly and the tank starts to drain, filling the void formed by the separation of the water columns. When the flow in the upper column starts to reverse, the check valves at the one-way tank close before any appreciable reverse flow is established in the discharge line. Thus there is no pressure rise when the water columns rejoin. The initial level of water in the one-way surge tank is usually maintained automatically with float control or altitude valves. It should be noted that the one-way surge tank does not act during the start-up cycle of the pump discharge line and that it must also be protected against freezing.

**AIR CHAMBERS** An effective device for controlling the pressure surges in a long pump discharge line is a hydropneumatic tank or air chamber. The air chamber is usually located at or near the pumping plant. It can be of any desired configuration and may be placed in a vertical, horizontal, or sloping position. The lower portion of the chamber contains water and the upper portion contains compressed air. The desired air and water levels are maintained with float level controls and an air compressor. When the power failure occurs at the pump motor, the head and flow developed by the pump decrease rapidly. The compressed air in the air chamber then expands and forces water out of the bottom of the chamber into the discharge line, thus minimizing the velocity changes and waterhammer effects in the line. When the pump speed is reduced to the point where the pump cannot deliver water against the existing head, which is usually a fraction of a second after a power failure, the check valve at the discharge side of the pump closes rapidly and the pump then slows down to a stop. A short time later, the water in the discharge line slows down to a stop, reverses, and flows back into the air chamber. As the reverse flow enters the chamber, usually through a throttling orifice, the air volume in the chamber decreases and a head rise above the pumping head occurs in the discharge line. The magnitude of this head rise depends on the throttling orifice and on the initial volume of air in the air chamber.

The results of a large number of graphic waterhammer-air chamber solutions are given in Reference 7. Another presentation of air chamber charts using the rigid water column theory is given in Reference 8.

**SURGE TANKS** Because it has no moving parts that can malfunction, a surge tank is one of the most dependable devices that can be used at a pumping plant to reduce waterhammer resulting from rapid changes of flow in the discharge line subsequent to a power failure at the pump motor. Following a power failure, the water in the surge tank provides a nearby source of potential energy that will effectively reduce the rate of change of flow and the waterhammer in the discharge line. The charts given in Reference 7 provide a ready means for calculating the surges in the pipeline due to the sudden starting or stopping of a pump.

One of the disadvantages of a conventional surge tank is that because the top of the tank must extend above the normal hydraulic gradient to avoid spilling, the tank must be quite tall and expensive at high-head pumping installations. In order to obtain the most economical surge tank design, care should be given to the proper sizing of the throttling device at the base of the tank.

**NONREVERSE RATCHETS** Another device occasionally used for reducing waterhammer in a pump discharge line upon a power failure is a nonreverse ratchet on the pump and motor shaft, which prevents the reverse rotation of the pump. This device is effective for controlling waterhammer when there is a power failure because of the large reverse flow that can pass through the stationary impeller. Except on small pumps, experience to date with nonreverse ratchet mechanisms has been very disappointing. At a number of moderate-size pump installations where these devices were used, the shock to the pump and motor shaft system caused by the sudden shaft stoppage created other serious mechanical difficulties.

**Automatic Restart of Motors** At small unattended pumping plants, it is often desirable after a power failure to automatically return the pumps to service as soon as the power is restored. However, it was found that occasionally, after a very short power outage, an induction motor could restart and come quickly up to forward speed while a reverse flow was still passing through the pump. Under these conditions, waterhammer in the discharge line is very objectionable. If the pump motor has the capability of restarting under such transient conditions, a time delay or similar device should be installed at the motor controls so the pump can be started only when it is safe to do so.

### **Normal Pump Start-Up**

**WITH CONTROLLED VALVE OPENING** At some pumping plants, the pump is brought up to speed against a closed valve on the discharge side of the pump. The valve is then opened slowly, and there is very little waterhammer in the discharge line. However, it will be found that nearly all of the pump flow in the discharge line is established with only a relatively small valve opening because the head losses across the valve decreases very rapidly during the opening stroke. For long discharge lines, the head loss and flow characteristics of the valve during the opening stroke must be considered in determining the optimum rate of opening.

**WITH CHECK VALVES** At pumping plants where the pipeline is held full with pump check valves, waterhammer in the discharge line due to a pump start-up can be objectionable in some cases. If the motor comes up to speed very rapidly, the pump will develop a pressure rise in the discharge line as the sudden increase in flow moves into the line. As noted previously and in Reference 1, this pressure rise is lower for radial-flow (low-specific-speed) pumps than for axial-flow (high-specific-speed) pumps (see Section 8.1).

**WITH CASING UNWATERED** At pumping plants equipped with large pumps, normal starting of a pump is often performed with the pump casing unwatered. This is accomplished by depressing the water level below the pump impeller by means of compressed air, which is admitted into the pump casing with the pump discharge valve closed and the discharge line full. After the motor has been synchronized on the line, the compressed air in the pump casing is released, allowing water to re-enter the pump from the suction elbow, after which the discharge valve is slowly opened. This type of operation has been satisfactory with most large pumping units, and there are normally no significant waterhammer



effects on the discharge line. However, there have been some difficulties with this type of operation at a few large pump units. In the latter case, when the rising water level in the suction elbow first reaches the pump impeller, a very fast pumping action occurs within a few seconds and a severe uplift of the pump and motor from the thrust bearing could occur at this moment. If the discharge valve is still closed when this fast pumping action occurs, there is no waterhammer effect in the discharge line.

**WITH SURGE OR AIR CHAMBERS** With a surge tank or air chamber at the pumping plant, it makes very little difference whether the increased pump flow is sudden or gradual, inasmuch as the major portion of the sudden increased flow will enter the surge tank or air chamber. With these devices, the steep front of the pressure rise at the pump is transformed into a smaller pressure rise in the discharge line and a subsequent slow oscillating movement in the surge tank or air chamber.

**NORMAL PUMP SHUTDOWN** The pumping installation that produces the least waterhammer effect in a pump discharge line during a normal pump shutdown is one in which the control valve on the discharge side of the pump is first closed and the power to the pump motor then is shut off. If only check valves are in operation on the discharge side of the pumps and the power to one of several pumps motors connected to the same discharge line is cut off, the flow at the pump that has been shut down will reverse rapidly and the check valve will close rapidly. The use of antislam or slow-closing features at the check valves will reduce the waterhammer effect in the discharge line.

## CONCLUSIONS

A variety of waterhammer control devices for pumping plants are available to the designer. In most cases, the experienced designer can narrow the choice of the most suitable device to a few practical alternatives. A prior knowledge of the available waterhammer solution for these devices will reduce the amount of detailed computational work that must be done to determine the critical hydraulic transient effects.

**EXAMPLE** Consider a power failure at the pumping plant installation shown in Figure 9. This installation consists of three pumps that discharge into a steel pipeline. Aside from isolation valves, there are no check valves in the system. The basic data for this installation are as follows:

$$D = 32 \text{ in}; e = 3/16 \text{ in}; Q_0 = Q_R = 33.7 \text{ ft}^3/\text{s} \text{ (for three pumps)}$$

$$V_0 = 6.03 \text{ ft/s (for three pumps)}; H_0 = H_R = 220 \text{ ft}$$

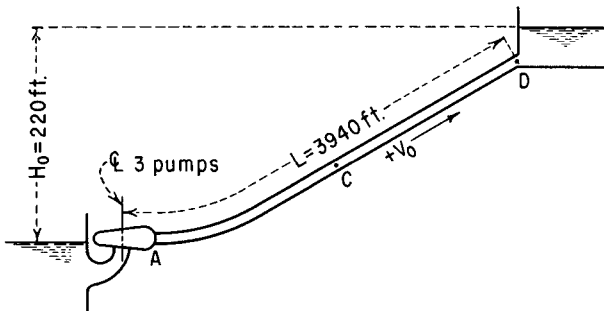
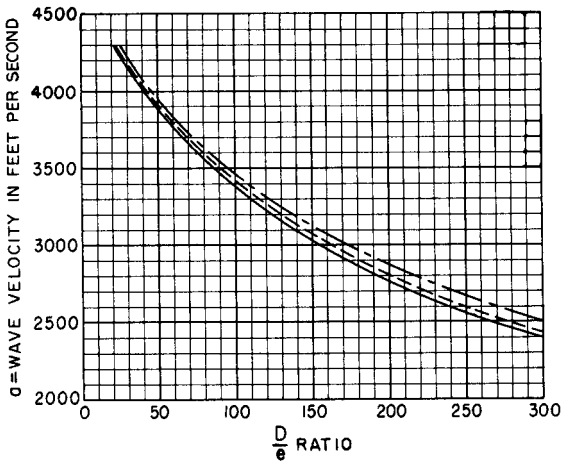


FIGURE 9 Pipeline profile



$$a = \sqrt{\frac{1}{\frac{w}{g} \left( \frac{1}{K} + \frac{Dc_1}{Ee} \right)}}$$

where:

$a$  = wave velocity (ft. per sec.)

$g$  = acceleration of gravity (ft. per sec<sup>2</sup>)

$\frac{D}{e}$  =  $\frac{\text{diameter of pipe}}{\text{thickness of pipe}}$

$E$  = Young's modulus for steel pipes =  $4.32 \times 10^9$  (lb. per ft.<sup>2</sup>)

$K$  = volume modulus of water =  $43.2 \times 10^6$  (lb. per ft.<sup>2</sup>)

$w$  = 62.4 = specific weight of water (lb. per ft.<sup>3</sup>)

$\mu$  = 0.3

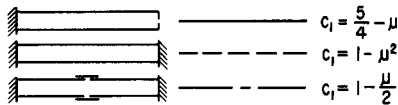


FIGURE 10 Pressure wave velocity in steel pipes

400-hp motors at each pump

$WR^2$  of each pump and motor = 385 lb-ft<sup>2</sup>

$$N_R = 1760 \text{ rpm}; \eta_R = 0.847$$

$$\frac{D}{e} = \frac{32}{0.1875} = 171$$

$a$  = 3000 ft/s from Figure 10

$$\frac{2L}{a} = \frac{2(3940)}{3000} = 2.63 \text{ s}$$

$$2\rho = \frac{aV_0}{gH_0} = \frac{(3000)(6.03)}{(32.2)(220)} = 2.55$$

$$K = \frac{(91,600)(H_R Q_R)}{WR^2 \eta_r N_R^2} = \frac{(91,600)(220)(33.7)}{3(385)(0.847)(1760)^2} = 0.224$$

$$K \frac{2L}{a} = 0.59$$

From Figures 1 to 8 the following results are obtained.

1. Downsurge at pump =  $(0.92)(220) = 202$  ft
2. Downsurge at midlength =  $(0.64)(220) = 141$  ft
3. Upsurge at pump =  $(0.42)(220) = 92$  ft
4. Upsurge at midlength =  $(0.23)(220) = 51$  ft
5. Maximum reverse speed =  $(1.45)(1760) = 2550$  rpm
6. Time of flow reversal at pump =  $3.5 L/a = 4.6$  s
7. Time of zero pump speed =  $5.8 L/a = 7.6$  s
8. Time of maximum reverse speed =  $10.0 L/a = 13.1$  s

As noted in the discussion on pumps equipped with check valves, the upsurge, or head rise, at the pump above the normal head would have been about 202 ft if there were check valves at the pumps that closed at the time of flow reversal.

### **PRESSURE PULSATIONS IN PUMPING SYSTEMS**

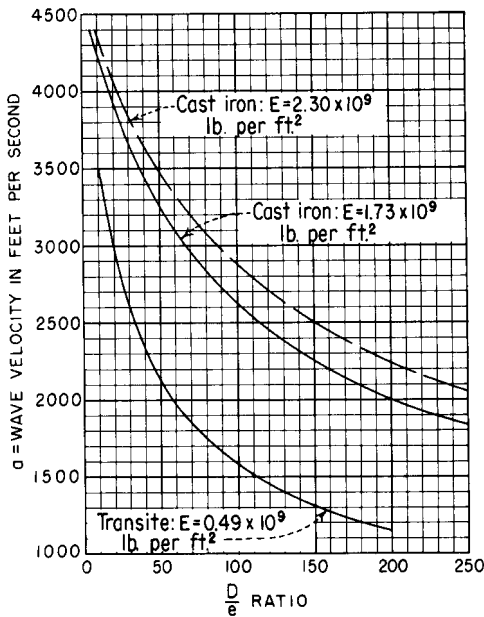
---

Motor-driven centrifugal pumps often produce objectionable pressure pulsations in pump discharge lines. The frequency of these pulsations results from the rotating and stationary components of the pump. The following pressure pulsation frequencies have been observed at a number of major pump installations:

1. Fundamental shaft frequency, once-per-revolution pressure pulsation
2. Impeller vane frequency, product of the shaft frequency and the number of impeller vanes
3. Scroll case frequency, product of shaft frequency and the number of guide vanes at either the inlet or discharge side of the pump

**Pressure Pulsations at Fundamental Shaft Frequency** In pumping systems, objectionable pressure pulsations with a frequency corresponding to the shaft frequency result primarily from a hydraulic unbalance in the pump impeller. The source of such unbalance is usually an eccentricity of the flow passage in the impeller, but in some cases it may be the eccentricity of the outer periphery of the impeller and the pumping action exerted by this eccentricity.

Considerable care must be taken when dynamically balancing a pump impeller to avoid pressure pulsations. In accomplishing this, balance weights are often welded to the top surface or an eccentric machine cut is taken on the outer periphery. Although such surfaces are out of sight after the unit is assembled, objectionable pressure pulsations with a frequency corresponding to the rotational speed of the unit can occur. Such sources of pressure pulsations are very difficult to correct after the unit has been installed. In order to avoid such difficulties, any welding at the top surface or metal removal at the outer periphery of the impeller should be done in such a manner that these surfaces remain smooth and concentric with the axis of rotation. Balance weights on surfaces normal to the axis of rotation should be applied or covered in such a manner that the surface remains flat, smooth, and normal to the axis of rotation.



$$a = \sqrt{\frac{1}{\frac{w}{g} \left( \frac{1}{K} + \frac{Dc_1}{Ee} \right)}}$$

where:

$a$  = wave velocity (ft. per sec.)

$g$  = acceleration of gravity (ft. per sec.<sup>2</sup>)

$\frac{D}{e}$  =  $\frac{\text{diameter of pipe}}{\text{thickness of pipe}}$

$E$  = Young's modulus for pipe material (lb. per ft.<sup>2</sup>)

$K$  = volume modulus of water =  $43.2 \times 10^6$  (lb. per ft.<sup>2</sup>)

$w$  = 62.4 = specific weight of water (lb. per ft.<sup>3</sup>)

$c_1$  =  $1 - \mu^2$

$\mu$  = 0.3.

FIGURE 11 Pressure wave velocity in cast iron and transite pipes

**Pressure Pulsations at Impeller Vane Frequency** The tongue of the pump is the source of the pressure pulsations that are transmitted to the discharge line with a frequency equal to the product of the shaft frequency and the number of impeller vanes. An explanation of the phenomenon is as follows. The velocity distribution at the exit of the pump impeller is not uniform. As this nonuniform flow passes the tongue of the pump casing, an abrupt change in the direction of the impeller exit velocity vector occurs at the proximity of the tongue. This produces a positive pressure wave at the pressure face and a negative pressure wave at the back face of the tongue. From this location, the positive pressure wave travels directly up the discharge line and the negative pressure wave travels completely around the pump casing and is attenuated before reaching the discharge line. These positive pressure pulsations have a frequency equal to the product of the pump speed and the number of impeller vanes. The most effective method for reducing the mag-

nitude of these pressure pulsations is to provide large radial clearance between the outer diameter of the impeller and all guide vanes, consistent with the head discharge requirements. Several manufacturers adopt a minimum radial clearance of 5% of the impeller diameter.

**Pressure Pulsations due to Blade-Vane Combinations** Objectionable pressure pulsations in pumping systems have been observed at certain multiples of impeller blade passing frequency and the frequency of guide vanes times rotation speed. These pulsations arise from interaction of the flow fields of critical combinations of the numbers of impeller blades and adjacent guide vanes which are located upstream or downstream of the impeller.

The strongest excitation from such pulsations occurs when the number of guide vanes is an exact multiple of the number of impeller blades. This is explained as follows: As the pump impeller rotates, the flow fields of all of the impeller blades simultaneously cross the flow fields between a corresponding number of guide vanes. This disturbance in the flow pattern by all of the runner blades simultaneously produces pressure changes inside the unit at a frequency equal to the number of impeller blades or guide vanes times the rotating speed.

More complex interactions occur for other blade-vane combinations. The remedy for eliminating such excitations is to avoid adverse combinations of impeller blades and adjacent guide vanes. Guidelines for making the proper choice of these combinations are presented in Section 2.1 under the subheading, Blade-Vane Combinations, and the theory described in more detail in References 33 and 65 of that section.

## REFERENCES

---

1. Donsky, B. "Complete Pump Characteristics and the Effects of Specific Speeds on Hydraulic Transients." *ASME J. Basic Eng.*, December 1961.
2. Jones, S. S. "Water-Hammer in a Complex Piping System: Comparison of Theory and Experiment." *ASME Paper 64-WA/FE-23*, New York, 1964.
3. Kinno, H., and Kennedy, J. F. "Waterhammer Charts for Centrifugal Pump Systems." *Proc. ASCE, J. Hydraulics Div.*, May 1965.
4. Lundgren, C. W. "Charts for Determining Size of Surge Suppressors for Pump Discharge Lines." *ASME J. Eng. Power*, Jan. 1967.
5. Kephart, J. T., and Davis, K. "Pressure Surges Following Water-Column Separation." *Trans, ASME J. Basic Eng.*, September 1961.
6. Parmakian, J. "One-Way Surge Tanks for Pumping Plants." *Trans. ASME* 80, October 1958.
7. Parmakian, J. *Waterhammer Analysis*. Dover, New York, 1963.
8. Combes, G., and Borot, B. "New Graph for the Calculation of Air Reservoirs, Account Being Taken of the Losses of Head." *La Houille Blanche*, October–November. 1952.

## FURTHER READING

---

Martin, C. S. "Representation of Pump Characteristics for Transient Analysis: Performance Characteristics of Hydraulic Turbines and Pumps." FED vol. 6 *ASME*, 1983.

Parmakian, J. "Pressure Surges at Large Pump Installations." *Trans, ASME*, August 1953.

Parmakian, J. "Pressure Surges in Pump Installations." *Trans. ASCE* 120, 1955.

Parmakian, J. "Unusual Aspects of Hydraulic Transients in Pumping Plants." *J. Boston Soc. Civil Eng.*, January 1968.

*Proceedings of the Second International Conference on Pressure Surges*. London, 1976. BHRA Fluid Engineering, Cranford, Bedford MK430AJ, England.

---

# SECTION 8.4

---

# PUMP NOISE

---

FRED R. SZENASI  
CECIL R. SPARKS  
J. C. WACHEL

The major concern regarding pump noise falls into two categories:

1. Noise levels that do not meet applicable environmental criteria. Examples range from personnel noise exposure criteria to overside noise criteria for submarines.
2. Noise signatures that can be used to diagnose faulty pump operation or incipient failure.

The proliferation of industrial noise regulations in recent years has taken much of the guesswork out of allowable noise levels insofar as personnel and community exposure is concerned, and various noise standards have specified noise measurement techniques. Several organizations have developed test procedures and codes for machinery-generated noise levels.<sup>1,2</sup> The Hydraulic Institute code was specifically developed for the measurement of airborne sound generated by pumps (Reference 3).

The most common approach for controlling airborne noise levels from pumps is to interrupt the paths by which noise reaches the listener. When noise is an indicator of abnormal pump operation, modification of pump internals or operating conditions is normally required.

The measurement of noise for diagnostic purposes is not well prescribed, either for instrumentation or for interpretation. Even a well-designed and properly operated pump will of course produce noise. Variations in noise amplitude and frequency that result from malfunction or improper operating conditions will depend upon the type and design of the pump and the type of problem causing the noise. Measurement and analysis techniques for interpreting these signatures will depend upon whether the noise is solid-, liquid-, or airborne and upon the nature of coexisting noise from other sources.

Determining the source and cause of noise is the first step in evaluating whether noise is normal or an indicator of possible problems. Noise in pumping systems can be generated both by the mechanical motion of pump components and by the liquid motion in the pump

and piping systems. Liquid noise sources can result from vortex formation in high-velocity (shear) flow, from pulsating flow, and from cavitation and flashing.

Noise from internal mechanical and liquid sources can be propagated to the environment by several paths, including the pump and support structure, attached piping, the liquid in the piping, and ultimately the surrounding air itself.

This section discusses various pump noise-generating mechanisms (sources) and common noise conduction paths as a basis for both effective diagnostics and treatment.

## **SOURCES OF PUMP NOISE**

---

Effective control of pump noise requires knowledge of the liquid and mechanical noise-generation mechanisms and the paths by which noise can be transmitted to a listener.

**Mechanical Noise Sources** Mechanical sources are vibrating components or surfaces which produce acoustic pressure fluctuations in an adjacent medium. Examples are pistons, rotating unbalance vibrations, and vibrating pipe walls.

In positive displacement pumps, noise is generally associated with the speed of the pump and the number of pump plungers. Liquid pulsations are the primary mechanically induced noise, and these in turn can excite mechanical vibrations in components of both pump and piping system. Incorrect crankshaft counterweights will also cause shaking at running speed, which may loosen anchor bolts and produce rattling of the foundation or skid. Other mechanical noises are associated with worn bearings on the connecting rods, worn wrist pins, or slapping of the pistons or plungers.

In centrifugal machines, improper installation of couplings often causes mechanical noise at twice pump speed (misalignment). If pump speed is near or passes through the lateral critical speed, noise can be generated by high vibrations resulting from imbalance or by the rubbing of bearings, seals, or impellers. If rubbing occurs, it may be characterized by a high-pitched squeal. Windage noises may be generated by motor fans, shaft keys, and coupling bolts.

**Liquid Noise Sources** When pressure fluctuations are produced directly by liquid motion, the sources are fluid dynamic in character. Potential fluid dynamic sources include turbulence, flow separation (vorticity), cavitation, waterhammer, flashing, and impeller interaction with the pump cutwater. The resulting pressure and flow pulsations may be either periodic or broad-band in frequency and generally excite either the piping or the pump itself into mechanical vibration. These mechanical vibrations can then radiate acoustic noise into their environment.

In general, pulsation sources are of four types in liquid pumps:

1. Discrete-frequency components generated by the pump impeller or plungers
2. Broad-band turbulent energy resulting from high flow velocities
3. Impact noise consisting of intermittent bursts of broad-band noise caused by cavitation, flashing, and waterhammer
4. Flow-induced pulsations caused by periodic vortex formation when flow is past obstructions and side branches in the piping system

A variety of secondary flow patterns that produce pressure fluctuations are possible in centrifugal pumps, as shown in Figure 1, particularly for operation at off-design flow. The numbers shown in the flow stream are the locations of the following flow mechanisms:

1. Stall
2. Recirculation (secondary flow)
3. Circulation
4. Leakage

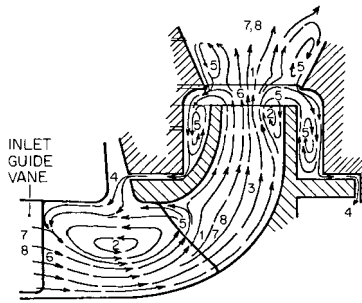


FIGURE 1 Secondary flows in and around a pump impeller stage (Reference 11)

5. Unsteady flow fluctuations
6. Wake (vortices)
7. Turbulence
8. Cavitation

Most of these unstable flow patterns produce vortices by boundary layer interaction between a high-velocity and low-velocity region in a fluid field, for example, by flow around obstructions or past deadwater regions or by bidirectional flow. The vortices, or eddies, are converted to pressure perturbations as they impinge on the sidewall and may result in localized vibration excitation of the piping or pump components. The acoustic response of the piping system can strongly influence the frequency and amplitude of this vortex shedding. Experimental work has shown that vortex flow is most severe when a system acoustic resonance coincides with the natural or preferred generation frequency of the source. This source frequency has been found to correspond to a Strouhal number ( $S_n$ ) from 0.2 to 0.5, where

$$S_n = \frac{f_e D}{V}$$

where  $f_e$  = vortex frequency, Hz

$D$  = a characteristic dimension of the generation source, ft (m)

$V$  = flow velocity in the pipe, ft/s (m/s)

For flow past tubes,  $D$  is the tube diameter, and for branch piping excitation,  $D$  is the diameter of the branch pipe. The basic Strouhal equation is further defined in Table 1, items 4A and B. As an example, flow at 100 ft/s (30 m/s) past a 12-in diameter (0.3-m) stub line would exhibit instability tendencies at a frequency of approximately 50 Hz. If the stub is acoustically resonant at a frequency near 50 Hz, rather large pulsation amplitudes can result.

When a centrifugal pump is operated at flows less than or greater than best efficiency capacity, noise is usually heard around the pump casing. The magnitude and frequency of this noise vary from pump to pump and are dependent on the magnitude of the pump head being generated, the ratio of  $NPSH$  required to  $NPSH$  available, and the amount by which pump flow deviates from ideal flow. Noise is often generated when the vane angles of the inlet guide, impeller, and casing (or diffuser) are incorrect for the actual flow rate. Another major source contributing to this noise is referred to as *recirculation*.<sup>4,5</sup>

Before the pressure of the liquid flowing through a centrifugal pump is increased, the liquid must pass through a region where its pressure is less than that existing in the suction pipe. This is due in part to acceleration of the liquid into the eye of the impeller. It is also due to flow separation from the impeller inlet vanes. If flow is in excess of design and



**TABLE 1** Piping vibration excitation forces

Generation mechanism	Excitation frequency $f_e$ , Hz
1. Reciprocating compressors	$nf$
2. Reciprocating pumps	$nf, nPf$
3. Centrifugal compressors and pumps	$nf, nBf, nvf$
4. Flow excitation	
A. Flow through restrictions	$\frac{0.2V}{D}$ to $\frac{0.5V}{D}$
B. Flow past stubs	$\frac{0.5V}{D}$
C. Flow turbulence due to quasi-steady flow	0–30 Hz (typically)
D. Cavitation and flashing	Broad band

$n = 1, 2, 3, \dots$

$f$  = running speed, Hz

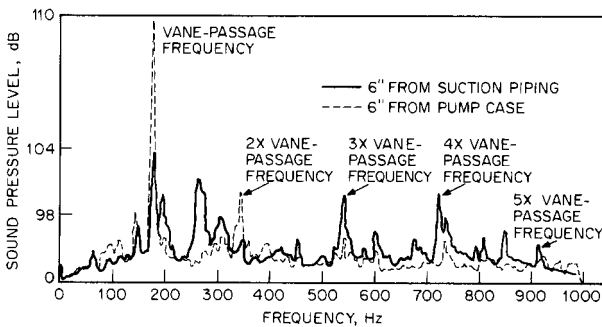
$P$  = number of pump plungers

$B$  = number of blades

$v$  = number of volutes or diffuser vanes

$V$  = flow velocity, ft/s (m/s)

$D$  = restriction diameter, ft (m)

**FIGURE 2** Noise spectra of cavitation and vane passage on a centrifugal pump

the incident vane angle is incorrect, high-velocity, low-pressure eddies will form. If the liquid pressure is reduced to the vaporization pressure, the liquid will flash. Later in the flow path the pressure will increase. The implosion that follows causes what is usually referred to as *cavitation* noise. The collapse of the vapor pockets, usually on the nonpressure side of the impeller blades, causes severe damage (blade erosion) in addition to noise.

Sound levels measured at the casing of an 8000-hp (5970-kW) pump and near the suction piping during cavitation are shown in Figure 2. The cavitation produced a wide-band shock that excited many frequencies; however, in this case, the vane passing frequency (number of impeller blades times revolutions per second) and multiples of it predominated. Cavitation noise of this type usually produces very-high-frequency noise, best described as “crackling.”

Cavitation-like noise can also be heard at flows less than design, even when available inlet *NPSH* is in excess of pump required *NPSH*, and this has been a puzzling problem. An explanation offered by Fraser<sup>4,5</sup> suggests that noise of a very low random frequency but very high intensity results from backflow at the impeller eye or at the impeller discharge,

or both, and every centrifugal pump has this recirculation under certain conditions of flow reduction. Operation in a recirculating condition can be damaging to the pressure side of the inlet or discharge impeller blades (and also to casing vanes). Recirculation is evidenced by an increase in loudness of a banging type, random noise, and an increase in suction or discharge pressure pulsations as flow is decreased. Refer to Subsections 2.3.1 and 2.3.2 for further information.

Pressure regulators or flow control valves may produce noise associated with both turbulence and flow separation. These valves, when operating with a severe pressure drop, have high flow velocities that generate significant turbulence. Although the generated noise spectrum is very broad-band, it is characteristically centered around a frequency corresponding to a Strouhal number of approximately 0.2.

**CAVITATION AND FLASHING** For many liquid pump piping systems, it is common to have some degree of flashing and cavitation associated with the pump or with the pressure control valves in the piping system. High flow rates produce more severe cavitation because of greater flow losses through restrictions.

In the suction piping of positive displacement pumps, high-amplitude pulsations can be generated by the plungers and amplified by the system acoustics and cause the dynamic pressure to periodically reach the vapor pressure of the liquid even though the suction static pressure may be above this pressure. As the cyclic pressure increases, the vapor bubbles collapse, producing noise and shock to the system, and this can result in erosion as well as undesirable noise. (See Figure 9, Section 3.4.)

Flashing is particularly common in hot water systems (feedwater pump systems) when the hot, pressurized water experiences a decrease in pressure through a restriction (for example, flow control valve). This reduction of pressure allows the liquid to suddenly vaporize, or flash, which results in a noise similar to cavitation. To avoid flashing after a restriction, sufficient back pressure should be provided. Alternately, the restriction could be located at the end of the line so the flashing energy can dissipate into a larger volume. Refer to Subsec. 2.3.4 for additional information.

## **NOISE CONTROL TECHNIQUES**

---

Environmental noise usually does not emanate directly from the energy source; rather, it is transmitted along mechanical or liquid paths before it finally radiates from some vibrating surface into the surrounding environment.

The approaches to treating pump noise generally include the following:

1. **Source modification** Modify the basic pump design or operating condition to minimize the generation of acoustic energy.
2. **Interruption of transmission** Prevent sources from generating airborne (or over-side) noise by interrupting the path between the energy source and the listener. This approach may range from isolation mounts at the source to physically removing the listener.

**Source Modification** Equipment modification to eliminate the noise source is usually quite specific to each particular situation; therefore, only general guidelines can be given. Many technical papers relate pump configurational modifications to the degree of noise reduction achieved; however, noise reduction depends on many parameters, and hence a particular modification may or may not help in a specific case. On the other hand, if the noise results from a resonant condition in the pump system, almost any reasonably conceived modification can destroy the resonance with varying degrees of improvement.

Some of the source modification approaches for pump applications are:

1. Increase or decrease pump speed to avoid system resonances of the mechanical or liquid systems.
2. Increase liquid pressures (*NPSH*, and so on) to avoid cavitation or flashing; decrease suction lift.

3. Balance rotating or oscillating components.
4. Change drive system to eliminate noisy components.
5. Correct acoustic resonance to minimize liquid-borne energy.
6. Modify centrifugal pump casing vanes so clearance between impeller diameter and casing cutwater (tongue) or diffuser vanes is increased.
7. Modify centrifugal pump impeller discharge blade configuration by pointing, slanting, grooving, adding holes, or staggering one-half pitch (if double suction).
8. Modify centrifugal pump casing cutwater (tongue) by slanting or adding holes.
9. Replace pump with different model or type to permit operation at reduced speed and the least number required.
10. If noise is due to operation of a centrifugal pump at flows less than design and recirculation is the problem, install minimum flow recirculation system bypass to increase total pump flow; if several pumps are operating in parallel, operate all pumps at the same speed and the least number required.
11. Use heavier bearing lubricant or increase number of bearing rolling elements.
12. Inject small quantity of air into the suction of a centrifugal pump to reduce cavitation noises.

The degree of improvement that can be achieved by any of the source modification approaches obviously depends upon the particulars of each installation, that is, the basic causes of excess noise. Modification of the pump internals, for example, is extremely difficult in existing installations and can produce undesirable side effects unless the pump was poorly designed or selected initially.

As described earlier, the major sources of internal noise in reciprocating pumps are usually associated with piston-induced pulsations, piston mechanical reactions, turbulence, vortex formation from separated flow around obstructions, and cavitation. In centrifugal pumps, in addition to recirculation noise, interaction of the impeller flow with the pump case (especially the cutwater), high-velocity and pressure gradients at the impeller blade tip, and flow separation can make significant contributions to pulsation levels and noise. Internal modifications to the pump can ameliorate any or all of these conditions if they are severe initially. The techniques are well known to most pump designers: Use adequate valve sizes, avoid high velocities and obstructed flows, keep pressures above the vapor pressure of the fluid being pumped, degasify the fluid, provide adequate pulsation control equipment, and maintain proper angles of attack in centrifugal machines.

Many references give examples of how changing pump design parameters affects noise.<sup>6-10</sup> Although such examples are valuable, they are of interest more in suggesting approaches than in predicting the degree of noise reduction that can be achieved in other pump applications.

Sudo, Komatsu, and Kondo<sup>9</sup> investigated pressure pulsations (and noise) generated in a centrifugal pump as a result of interference between the impeller discharge vanes and the receiving spiral casing single cutwater vane. The geometry of the pump (Figure 3) defines the gap  $G$  between the impeller outer diameter  $D_2$  and the casing cutwater. How varying the gap  $G/D_2$  and the skew ratio (inclination of the cutwater or impeller vanes) affected discharge pressure pulsations is shown in Figure 4. Increasing  $G$  and the skew ratio decreases pulsation and noise amplitudes. Some investigators suggest that the ratio of cutwater diameter to impeller outer diameter be as large as 2:1 for optimum operation. When the cutwater diameter (or gap) is unknown, a rule of thumb suggested to optimize impeller diameter selection is not to use an impeller larger than 85% of maximum diameter.

To reduce the effect of impeller/casing vane passing pulsations, and consequently noise, double-suction impellers should have staggered vanes; i.e., the discharge vane tips should be shifted one-half pitch. This allows the fluctuation of the flow from each half of the impeller to interfere and thus reduces pressure pulsations at the pump discharge.

Florjancic, Schöffler, and Zogg<sup>10</sup> have reported that centrifugal pump impeller blade and casing tongue configuration can affect sound pressure levels and alter pump head and efficiency (Figure 5).

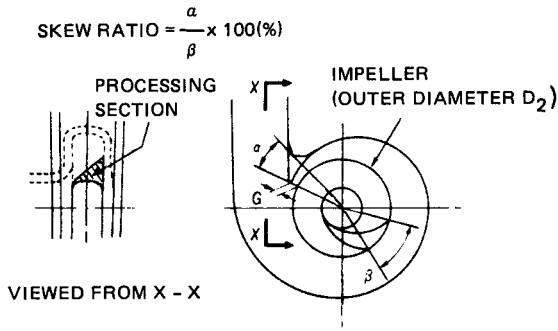


FIGURE 3 Cutwater of a spiral casing and impeller (Reference 9)

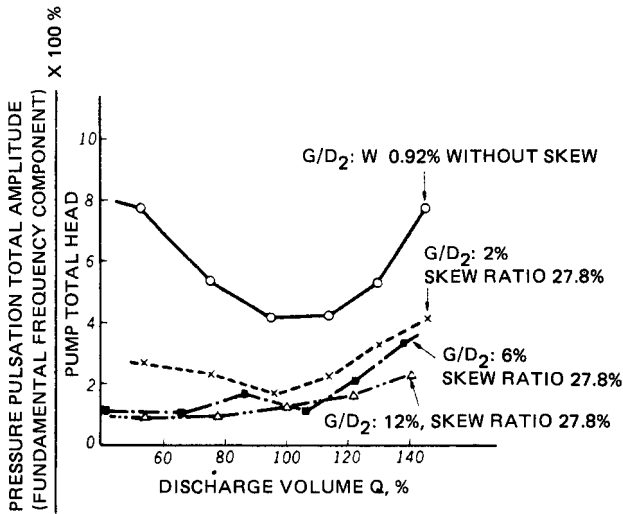


FIGURE 4 Effects of gap width between cutwater of a spiral casing and trailing edge of the impeller blade (Reference 9)

**Control of Noise Paths** These approaches consist of system modifications and treatments to disrupt the conduction of sound, whether borne by the structure, liquid, or air. They include approaches other than those that directly affect the originating source of oscillating energy (Figure 6).

**LIQUID PATH** Noise generated in the region of the pump is conducted both upstream and downstream by the liquid in the piping system. Such paths are most effectively reduced by acoustic (pulsation) filters or other pulsation control equipment, such as side branch accumulators (see Section 3.6).

**STRUCTURE-BORNE NOISE** Obvious paths for solid-borne noise are the attached piping and pump support systems. Oscillatory energy generated near the pump by pulsation, cavitation, turbulence, and so on, can be conducted as solid-borne noise for substantial distances

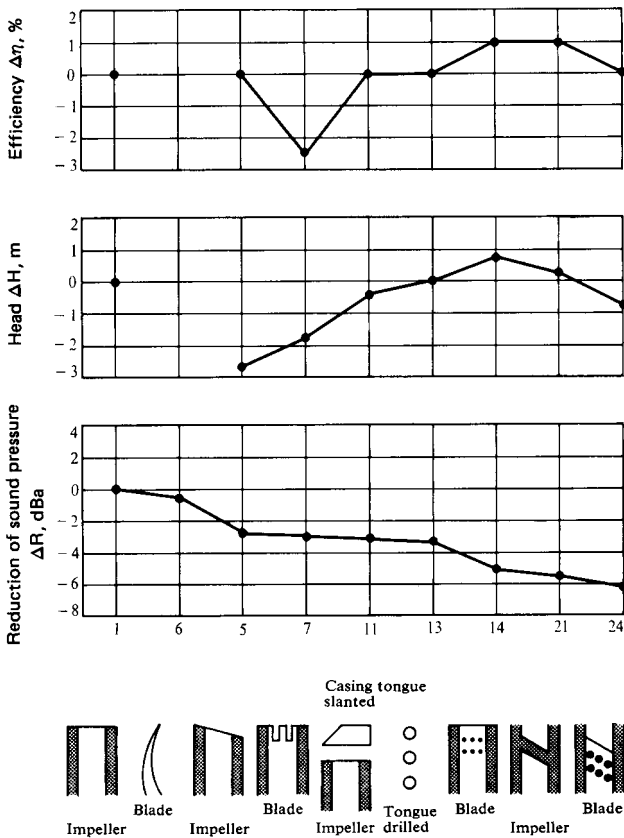
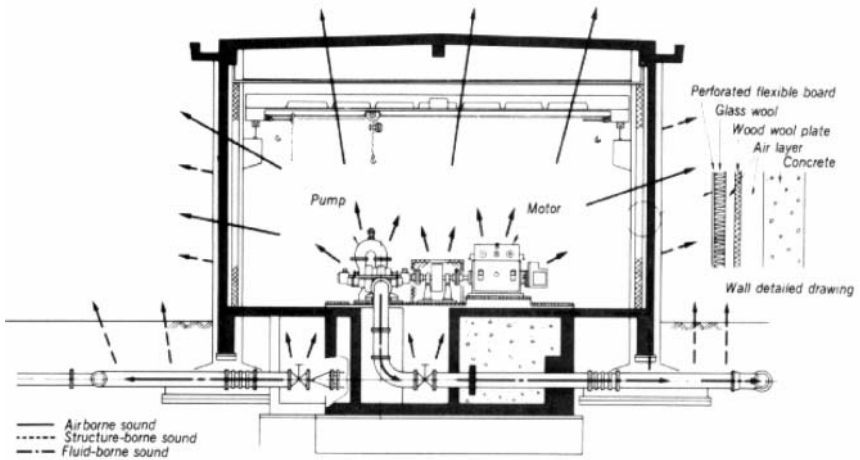


FIGURE 5 Reduction in sound pressure level with influences on head and efficiency at 100% flow for various impeller blade and casing tongue configurations (Reference 10)

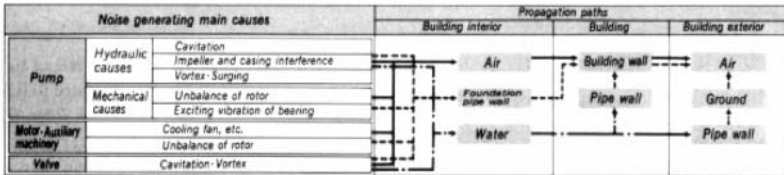
before it is radiated as acoustic noise into the atmosphere. Some success in controlling solid-borne noise propagation can be achieved by the use of flexible couplings in the piping systems, mechanical isolation (vibration mounts and so on) for the pump and drive systems, and resilient pipe hangers and supports.

Techniques for the vibration isolation of mechanical equipment are well known and available from many suppliers of vibration isolators or mounts. These may consist of resilient supports at each mounting point of the machine, although it is often necessary to mount the pump and drive system on a single rigid skid (to assure alignment) and then isolate the skid from its support system. For best isolation, the lowest resonant frequency of the supported system should be well below the minimum operating frequency, and none of the higher resonant modes should be coincident with running speed or multiples thereof.

The application of elastomeric coatings to the exterior surface of the pump or piping to damp pipe wall vibrations is normally ineffective except on very thin conduit. However, such coatings may have a small acoustic effect in confining or absorbing high-frequency noise that would otherwise be radiated by the pipe wall vibrations. (See the following discussion on pipe wraps.)



(a)



(b)

FIGURE 6 Noise propagation paths in a pumping plant (Reference 9)

**Airborne Noise** Although acoustic energy can be generated in the pumped liquid by purely fluid processes (turbulences and so on), most noise radiated to the surrounding air is the direct result of mechanical vibrations in the pump case, the pipe wall, or other structures to which the pump system is coupled by liquid or mechanical attachment. (The exceptions to purely mechanical sources are windage noise produced by the rotating coupling, by cooling air in the drive motors, and so on).

When excessive noise is encountered, the source or sources can sometimes be identified by making sound measurements at points in a grid around the suspect equipment and plotting sound level contours. A sound level contour of a typical flow control valve installation is shown in Figure 7. Octave band analyses or spectral analyses and contours can also provide clues by identifying the source of various frequency components of the noise. These components can also be compared with the information in Table 1 to aid in determining the source and location of the noise-generating mechanism.

The Hydraulic Institute standard<sup>3</sup> gives specific details of the procedures for noise measurement around pumps, including microphone locations (Figure 8), measurement procedures, and a data sheet (Figure 9).

The approaches for reducing noise from pumps and piping systems after it is airborne generally consist of either interrupting the transmission path (barriers) or controlling the reverberation characteristics of the pump room.

A highly reflective (reverberant) pump room or enclosure can increase pump noise levels several decibels by reflections of the noise back and forth in the enclosure. The maximum reduction that can be achieved by the application of acoustic absorption material to the interior surfaces is normally about 10 dB for a highly reverberant enclosure. At most, such a treatment can reduce noise levels to those that would exist if the pump were operating in the

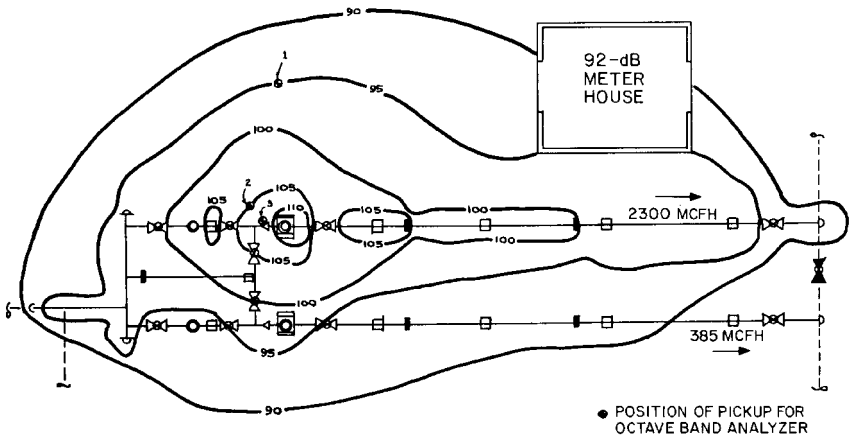


FIGURE 7 Contours of equal sound level (decibels) (Reference 12)

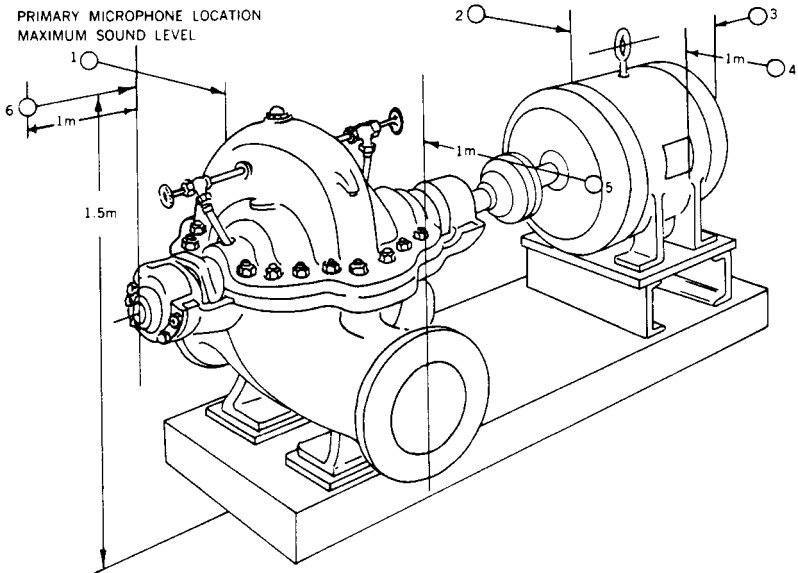


FIGURE 8 Placement of microphones on a horizontally split centrifugal pump (Hydraulic Institute ANSI/HI 2000 Edition Pump Standards, Reference 3)

open, totally free of reflecting surfaces. Quantitatively, the noise reduction  $NR$  in decibels that can be achieved is

$$NR = 10 \log \frac{\bar{\alpha}_a}{\bar{\alpha}_b}$$

where  $\bar{\alpha}_a$  = average absorption coefficient of the surfaces after treatment

$\bar{\alpha}_b$  = average absorption coefficient of the surfaces before treatment

AIRBORNE SOUND LEVEL TEST REPORT FOR PUMPING EQUIPMENT											REPORT FORM						
<b>SUBJECT:</b>																	
Model: _____			Manufacturer: _____			Serial: _____			Rated Pump Speed: _____			Capacity: _____			Total Head: _____		
Type of Driver: _____				Auxiliaries such as Gears: _____				Applicable Figure No: _____				Speed: _____					
Description: _____																	
<b>TEST CONDITIONS:</b>																	
Distance from Subject to Microphone: _____											Meters						
Operating Speed as Tested: _____																	
Height of Microphone Above Reflecting Plane: _____											Meters						
Reflecting Plane Composition: _____																	
Primary Microphone Location No: _____																	
Remarks: _____																	
<b>INSTRUMENTATION:</b>																	
Microphone: _____											No. _____						
Sound Level Meter: _____											No. _____						
Octave Band Analyzer _____											No. _____						
Calibrator: _____											No. _____						
Other: _____											No. _____						
<b>DATA:</b>																	
MIDBAND FREQ. Hz	db Ref. 2 x 10 <sup>-10</sup> N/m <sup>2</sup>	BACK- GROUND	LOCATION *										AV.				
	dB A		1	2	3	4	5	6	7	8	9	10					
	63																
	125																
	250																
	500																
	1k																
	2k																
	4k																
	8k																
*Corrected for background sound. Readings having 3 dB corrections must be reported in brackets. Only octave bands of interest as defined on page 299 need be reported.																	
TESTED BY: _____												DATE: _____					
REPORTED BY: _____												DATE: _____					

**FIGURE 9** Hydraulic Institute data sheet for measurement of airborne sound from pumping equipment (Hydraulic Institute ANSI/HI 2000 Edition Pump Standards, Reference 3)

The average absorption coefficient is defined as follows:

$$\bar{\alpha} = \frac{\alpha_1 A_1 + \alpha_2 A_2 + \alpha_3 A_3 + \dots + \alpha_n A_n}{A_1 + A_2 + A_3 + \dots + A_n}$$

where  $\alpha_1, \alpha_2, \alpha_3, \dots$  are absorption coefficients of various surface areas within the enclosure and  $A_1, A_2, A_3, \dots$  are the corresponding surface areas.

Absorption coefficients for typical building materials are given in Table 2. Note that the absorption coefficients vary with frequency, and hence calculated values of  $NR$  can be quite frequency-sensitive. Absorption data for various absorbing materials can best be obtained from the suppliers. One of the most common and most effective of such materials is fiberglass matting or the more rigid fiberglass board.

The noise reduction that can typically be attained with fiberglass piping insulation is shown in Figure 10. Note that noise reduction varies with noise frequency and with the thickness and density of the fiberglass matting. Densities of 5 to 6 lb/ft<sup>3</sup> (80 to 96 kg/m<sup>3</sup>), found in the rigid fiberglass board, are normally more effective than the 1 to 2 lb/ft<sup>3</sup> (16 to 32 kg/m<sup>3</sup>) found in rolled matting.

Normally, the average absorption in a room must be increased by a factor of at least three before noise improvement is discernible to the ear. Unless the absorption coefficient of the untreated room is less than about 0.3 in the frequency range of maximum noise, the



**TABLE 2** Sound absorption coefficients of common construction materials

Material	Frequency, Hz					
	125	250	500	1000	2000	4000
Brick						
Unglazed	0.03	0.03	0.03	0.04	0.04	0.05
Painted	0.01	0.01	0.02	0.02	0.02	0.02
Concrete block, painted	0.10	0.05	0.06	0.07	0.09	0.08
Concrete	0.01	0.01	0.015	0.02	0.02	0.02
Wood	0.15	0.11	0.10	0.07	0.06	0.07
Glass	0.35	0.25	0.18	0.12	0.08	0.04
Gypsum board	0.29	0.10	0.05	0.04	0.07	0.09
Plywood	0.28	0.22	0.17	0.09	0.10	0.11
Soundblox concrete block						
Type A (slotted), 6 in (15 cm)	0.62	0.84	0.36	0.43	0.27	0.50
Type B, 6 in (15 cm)	0.31	0.97	0.56	0.47	0.51	0.53
Carpet	0.02	0.06	0.14	0.37	0.60	0.65
Fiberglass typically 4 lb/ft <sup>3</sup> , (64 kg/m <sup>3</sup> ), hard backing						
1 in (2.5 cm) thick	0.07	0.23	0.48	0.83	0.88	0.80
2 in (5 cm) thick	0.20	0.55	0.89	0.97	0.83	0.79
4 in (10 cm) thick	0.39	0.91	0.99	0.97	0.94	0.89
Polyurethane foam, open-cell						
$\frac{1}{4}$ in (0.6 cm) thick	0.05	0.07	0.10	0.20	0.45	0.81
$\frac{1}{2}$ in (1.3 cm) thick	0.05	0.12	0.25	0.57	0.89	0.98
1 in (2.5 cm) thick	0.14	0.30	0.63	0.91	0.98	0.91
2 in (5 cm) thick	0.35	0.51	0.82	0.98	0.97	0.95
Hairfelt						
$\frac{1}{2}$ in (1.3 cm) thick	0.05	0.07	0.29	0.63	0.83	0.87
1 in (2.5 cm) thick	0.06	0.31	0.80	0.88	0.87	0.87

\*For specific grades, see manufacturer's data; note that the term *NCR*, when used, is a single-term rating that is the arithmetic average of the absorption coefficients at 250, 500, 1000, and 2000 Hz.

Source: Reference 8.

addition of absorbing material to the walls or ceiling will likely be ineffective. Nevertheless, the noise reduction could amount to 5 dB and thus could mean the difference between compliance and noncompliance with existing criteria.

The use of barriers near or enclosing the pump can be much more effective than environmental absorption treatments, particularly if the barriers totally confine the noise-producing components (Figure 11). Acoustic barriers simply interrupt the airborne path from the source to the listener. Such barriers work best (have the highest transmission loss) when

1. Their area density is high.
2. They are total enclosures and all joints are well sealed against air leaks.
3. They are not mechanically tied to the vibrating surfaces of the pump (that is, they are mechanically isolated).

For total enclosures, the barrier area density controls transmission loss for noise frequencies above the lowest mechanical flexural frequency of the barrier panels. Loosely sprung but well-sealed and heavy panels therefore serve this function well. Treating the interior of the enclosure with sound-absorbing material tends to reduce the apparent source strength by preventing reverberant buildups in the enclosure. Note that the use of a total enclosure around a pump may cause other operational problems that must be dealt

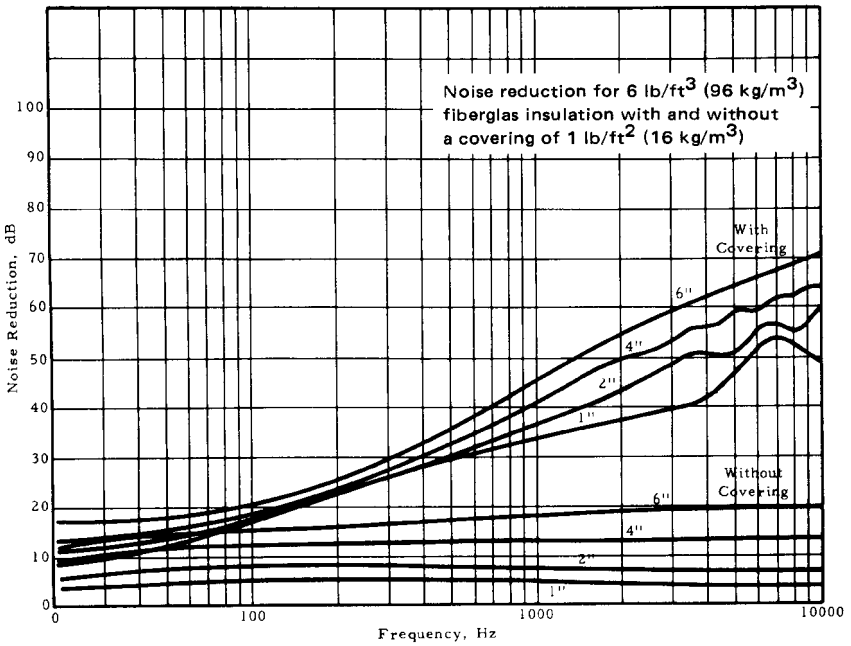


FIGURE 10 Noise reduction for piping with fiberglass insulation (1 in = 2.54 cm)

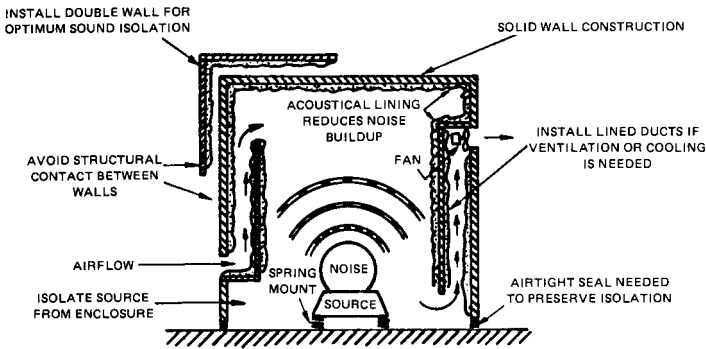


FIGURE 11 Design of an effective sound-isolating enclosure requiring air circulation for cooling (Reference 8)

with, for example, overheating, formation of explosive mixtures, or difficulty in getting to the pump for maintenance.

Although partial barriers around a pump usually cannot provide the degree of noise reduction afforded by total enclosures, they may be quite useful. Such barriers normally redirect the noise away from the listener and work best when they are located very near either the source or the listener. They also work better in an open or acoustically dead room than in a highly reverberant one. Their performance can often be enhanced by treating the interior (pump-side) surface with absorbing material or by reflecting the noise into

an absorbing surface. The transmission loss of partial barriers is usually not critical as long as it is 20 dB or greater, as reverberation and flanking noise paths will normally limit overall reduction to less than 20 dB.

Exterior control techniques for pipe noise usually consist of pipe wrapping materials in addition to the resilient pipe supports and hangers already mentioned. The function of such materials is identical to that of total enclosures; hence, pipe wraps should be

1. Massive (high area density)
2. Mechanically decoupled from the pipe (loosely sprung)
3. Airtight

For all the very-low-frequency noise, decoupling between a heavy, airtight outer coating and the vibrating pipe wall can be achieved by a compliant acoustic absorbing material, such as preformed fiberglass pipe insulation. This material provides some acoustic absorption of noise as it "passes through," but, more important, it provides vibratory decoupling between the vibrating pipe wall and the external pipe wrap shell or layer.

Multiple-layered panels or pipe wrap normally provide more attenuation than single homogenous layers, as long as the layers are mechanically decoupled. Examples of several pipe wrap configurations are given in Figure 12. Alternative lead-free materials are replacing leaded vinyl.

## NOISE MEASUREMENT

In very general terms, sound consists of cyclic modulations of ambient pressure at frequencies that are detectable to the human ear, normally between 30 Hz and 17 kHz. For our purposes, noise is simply unwanted sound. The complications in measuring noise or in assessing its effects on personnel arise chiefly because of the remarkable complexity of the human ear and its very nonlinear acoustic response with both frequency and amplitude.

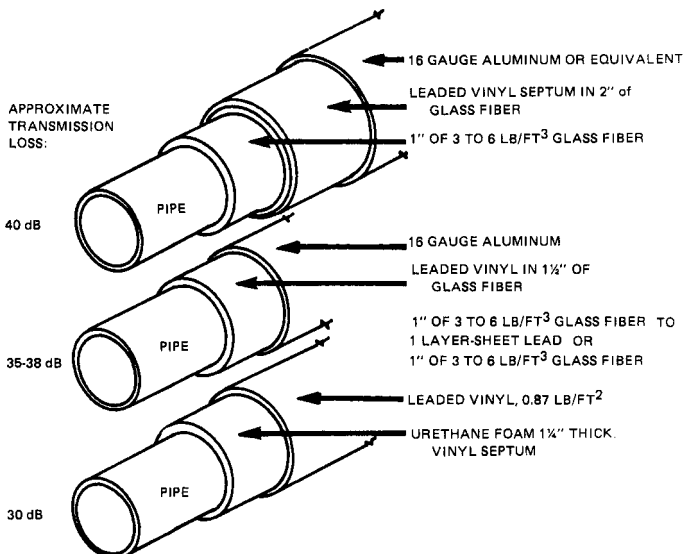


FIGURE 12 Three possible pipe wrap configurations (1 to = 2.54 cm; 1 lb/ft<sup>3</sup> = 16 kg/m<sup>3</sup>) (Reference 12)

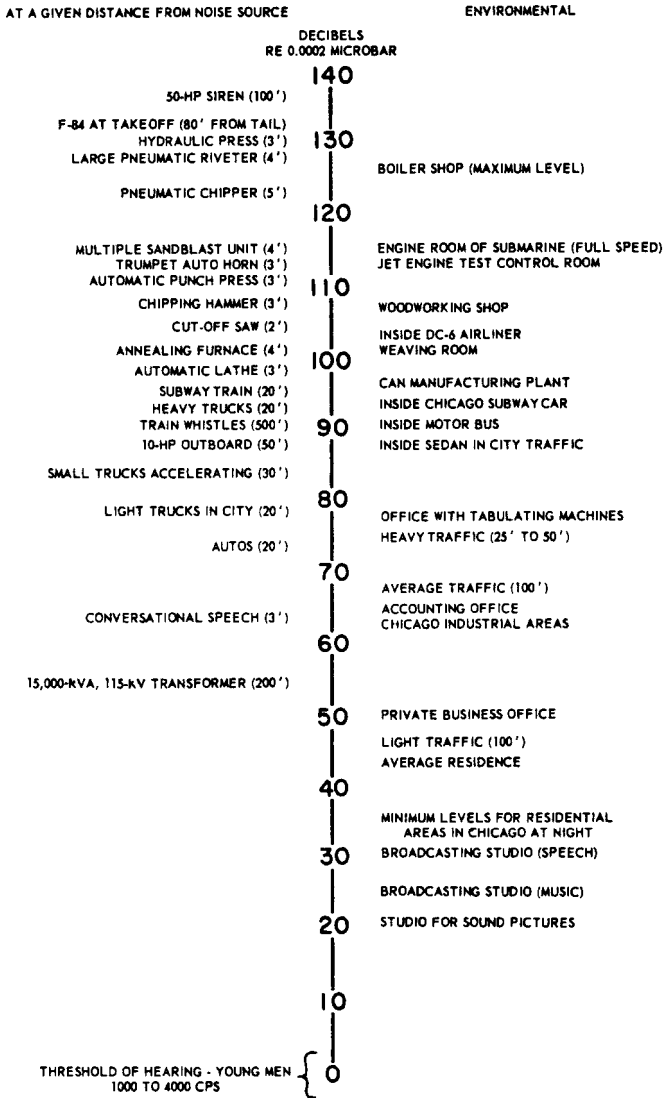


FIGURE 13 Typical overall sound levels (1 ft = 0.3048 m) (Reference 13)

The dynamic range of the human ear is 160 dB, from a minimum detectable level of about  $3.7 \times 10^{-9}$  lb/in<sup>2</sup> to about 0.37 lb/in<sup>2</sup> ( $2.6 \times 10^{-10}$  to 0.026 bar\*). In order to compensate for the ear's dynamic range, the decibel scale was adapted to roughly simulate the ear's non-linear sensitivity and reduce numerical sound level values to a manageable range. The strength of familiar sounds relative to their typical decibel level is given in Figure 13.

\*1 bar =  $10^5$  Pa.

The decibel is a unit of sound measurement relating the dynamic pressure variations produced by the source of interest to a reference sound pressure (0.0002  $\mu$ bar). The sound pressure level in decibels is equal to 20 times the common logarithm of this ratio:

$$SPL = 20 \log \left( \frac{P}{0.0002} \right)$$

where  $P$  is the rms sound pressure in microbars.

For example, if one sound pressure level is twice another, the measured noise level will be 6 dB greater.

The basic instrument used to measure sound intensity is the sound level meter, which provides a numerical reading of decibel values by integrating sound throughout the audible frequency spectrum. Because the frequency response of the ear varies with sound intensity, the sound level meter has three internal filters that can be used to approximate the ear's frequency response at 45, 75, and 95 dB. These are called the A, B, and C filters, respectively. In recent years, use of the C weighing filter has become popular in prescribing noise criteria. The dBC scale has been thus adapted, partially because it is easy to use and partially because it attenuates very-low-frequency noise, which is not as potentially injurious to the ear.

## CRITERIA

---

In order to decide whether noise treatment is necessary, the sound levels must be measured and compared with applicable criteria. Most protective noise criteria have been developed to protect a specific statistical sample of people from prescribed typical noise conditions and exposure patterns. Although such criteria are admittedly approximate, they are usually sufficiently conservative to protect a large majority of those who may be exposed, whether they are written to prevent hearing loss, community annoyance, speech and communication masking, or any of the other physiological or psychological effects of noise.

When noise criteria are legislated into noise codes or regulations, they normally specify noise measurement locations, instruments, and sampling times as well as allowable levels and exposure durations. Thus they have taken much of the guesswork out of evaluating machinery noise. The main criterion for pump and other machinery installations can be obtained from the U.S. Department of Labor, OSHA Bulletin 334. OSHA guidelines for allowable daily noise exposure as a function of time and sound pressure level for personnel near the installations are given in Table 3. The allowable exposure time depends upon the maximum sound level in the work space. When the noise exposure for personnel is intermittent, the allowable exposure may be calculated from Table 3 by computing the fractions of actual exposure time at a given noise level to the allowable exposure time at that level. If the sum of these fractions is less than 1, the noise level can be considered safe. It is important to know one underlying implication in this criterion. If a reduction of the noise level is not economically feasible, it may be reasonable to schedule operators' work so the criterion levels will not be exceeded. This rescheduling may permit a wider latitude in the final solution of a plant noise problem.

## MODEL TESTING

---

It is possible to conduct tests on reduced-size pumps and pumping systems in order to predict and adjust pressure pulsations and noise from the pump and piping. This has been successfully done by Sudo, Komatsu, and Kondo<sup>9</sup> using a model variable-speed, single-stage, double-suction pump in addition to mathematical computer confirmation. A comparison of performance with nonstaggered and staggered impeller vanes revealed the good pulsation suppression characteristics of the latter impeller configuration (Figure 14).

These investigators, in their modeling, used the following relationships to provide the required similarity between model and prototype:

**TABLE 3** OSHA noise exposure limits

Sound level, dBA	Allowable exposure time	
	Minutes	Hours
90	480	8.00
91	420	7.00
92	360	6.00
93	320	5.33
94	280	4.67
95	240	4.00
96	210	3.50
97	180	3.00
98	160	2.67
99	140	2.33
100	120	2.00
101	105	1.75
102	90	1.50
103	80	1.33
104	70	1.16
105	60	1.00
106	54	0.90
107	48	0.80
108	42	0.70
109	36	0.60
110	30	0.50
111	27	0.45
112	24	0.40
113	21	0.35
114	18	0.30
115 (maximum allowable level)	15	0.25

1. Equal ratios of pipe length to wavelength
2. Equal ratios of pipe cross-sectional area
3. Model pump speed adjusted to make the product of pulsation wavelength and frequency equal to the speed of sound in water

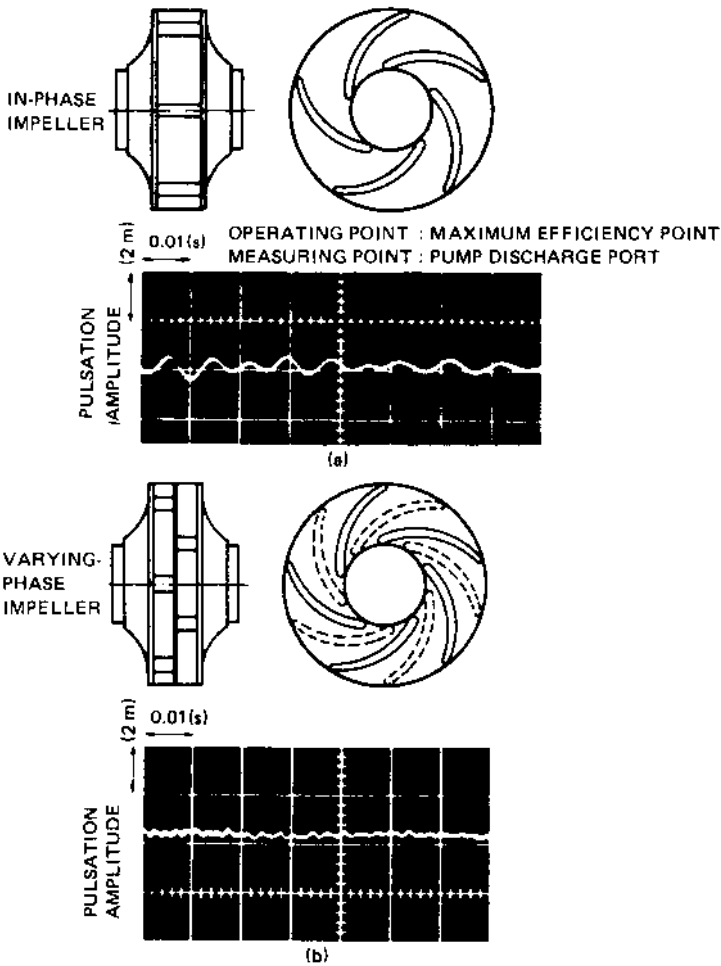


FIGURE 14 Comparison of pressure pulsation waveforms: (a) a double-suction in-phase centrifugal pump impeller and (b) a varying-phase (staggered) centrifugal pump impeller (Reference 9)

## REFERENCES

1. American National Standards Institute. Acoustical Terminology (Including Mechanical Shock and Vibration), ANSI Standard S1.1. New York, 1976.
2. American National Standards Institute. Specification for Sound Level Meters, ANSI Standard Sl.4. New York, 1971.
3. American National Standard for Pumps—General Guidelines for Types, Definitions, Application, Sound Measurement and Decontamination, ANSI/HI 9.1-9.5-2000, Hydraulic Institute, Parsippany, NJ [www.pumps.org](http://www.pumps.org).
4. Fraser, W. H. "Flow Recirculation in Centrifugal Pumps." In *Proceedings of the Tenth Turbomachinery Symposium*, Texas A&M, College Station, TX, 1981.

5. Fraser, W. H. "Recirculation in Centrifugal Pumps: Materials of Construction of Fluid Machinery and Their Relationship to Design and Performance." Paper presented at winter annual meeting of ASME, Washington, D.C., November 16, 1982.
6. Mayerson, N. "Sources of Noise in Power Plant Centrifugal Pumps with Considerations for Noise Reduction." *Noise Control Eng.* 2(2):74, 1974.
7. Evans, L. M. "Control of Vibration and Noise from Centrifugal Pumps." *Noise Control*, January 1958, p. 28.
8. Berendt, R. D., Corliss, E. L. R., and Ojalvo, M. S. *Quieting: A Practical Guide to Noise Control*. Handbook 119, U.S. Department of Commerce and National Bureau of Standards, Washington, D.C., July 1976.
9. Sudo, S., Komatsu, T., and Kondo, M. "Pumping Plant Noise Reduction." *Hitachi Rev.* 29(5):217, 1980.
10. Florjantit, D., Sabeffler, W., and Zogg, H. "Primary Noise Abatement on Centrifugal Pumps." *Sulzer Tech. Rev.* 1:24, 1980.
11. *Centrifugal Pump Hydraulic Instability*. CS-1445 Research Project 1266-18, Electric Power Research Institute, 3412 Hillview Ave., Palo Alto, CA, 1980.
12. Sharp, J. M., Damewood, G., Sparks, C. R., Hanchett, M. T. *Noise Abatement at Gas Pipeline Installations, Vol. I: Physiological, Psychological and Legal Aspects of Noise*. Project No. 23, American Gas Association, New York, 1959.
13. Peterson, A. P. G., and Gross, Jr., E. E. *Handbook of Noise Measurement*, 5th ed., General Radio, West Concord, MA, 1963.

## FURTHER READING

---

- Beranek, L. L. "Noise Reduction." In *Noise and Vibration Control*, paper for program at MIT, Cambridge, MA, 1960; published by McGraw-Hill, New York, 1971.
- Edison Electric Institute, *Electric Power Plant Environmental Noise Guide*, No. 78-51 chap. 4, Washington, D.C., 1978.
- Kamis, P. A. "Techniques for Reducing Noise in Industrial Hydraulic Systems." *Pollution Eng.*, May 1975, p. 46.
- Kondo, M., et al. "Pressure Fluctuations in Pump Pipeline." In *Proceedings of the 17th Congress IAHR, 1977-78*. International Association for Hydraulic Research, Delft, Netherlands.
- Matley, J., and staff of *Chemical Engineering: Fluid Movers, Pumps, Compressors, Fans and Blowers*, McGraw-Hill, New York, 1979.
- Rand, S. *More Sound Advice: How to Quiet Hydraulically Powered Equipment*, Bulletin 74-154, Troy, MI, 1974.
- Salmon, V., Mills, J. S., and Petersen, A. C. *Industrial Noise Control Manual*, Industrial Noise Services, contract no. HSM 99-73-82, Palo Alto, Calif., June 1975, Tables 4.1 and 4.2.
- Sparks, C. R., and Wachel, J. C. "Pulsation in Centrifugal Pump and Piping Systems." *Hydrocarbon Processing*, July 1977, p. 183.
- Thompson, A. R., and Hoover, R. M. "Reduction of Boiler Feed Pump Noise in an 800MW Coal-Fired Generating Unit." IEEE paper F78-819-5 delivered at Joint Power Generation Conference, Dallas, September 1978.
- Tung, P. C., and Mikasinovic, M. "Eliminating Cavitation from Pressure-Reducing Orifices." *Chem. Eng.*, December 1983, p. 69.
- Wojda, H. W. "First Aid for Hydraulic System Noises." *Pollution Eng.*, April 1975, p. 38.



C • H • A • P • T • E • R • 9

# **PUMP SERVICES**

---

# SECTION 9.1

---

# WATER SUPPLY

---

F. G. HONEYCUTT, JR.  
D. E. CLOPTON

## **SOURCES OF WATER**

---

**Surface Water** Surface water supplies are obtained from streams, rivers, lakes, and reservoirs. The quantity of water available from a surface supply can be determined with reasonable accuracy from yield studies that take into account the local effects of rainfall, runoff, evaporation and sedimentation rates, and other hydrological factors. Development of a surface supply usually requires pumps to transport raw water from the source to a treatment plant and to provide the head necessary for proper hydraulic operation of the treating facilities. Pumps utilized for this purpose are classified as low-lift pumps because relatively low discharge heads are required.

Selection of a specific type of pump for low-lift service is dependent on intake conditions. Because surface water supplies vary significantly in temperature, bacteria count, and turbidity at varying depths and because the water level may fluctuate considerably, it is necessary to provide some type of intake structure that will permit withdrawal of water at several elevations. Multiple intake ports equipped with trash racks and water screens provide this capability and provide protection from fish and debris. The design and location of the intake structure influence the selection of either a horizontal or vertical pump for low-lift service.

**Groundwater** In many areas of the United States where rainfall and runoff are sparse, significant supplies of water are available from underground sources. The groundwater table is formed when rainfall percolates through the soil and reaches a zone of saturation, the depth of which is governed by soil characteristics and subsurface conditions.

Groundwater can be developed as a source of supply through utilization of wells or springs. Shallow wells generally utilize the water table as a source, whereas deep wells

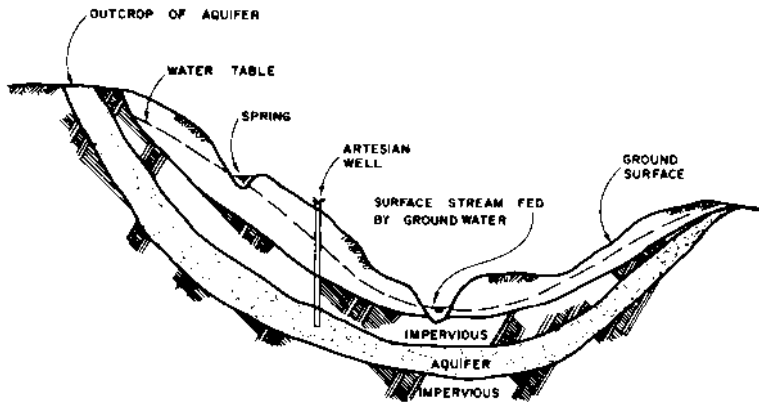


FIGURE 1 Subsurface conditions for development of groundwater supplies

utilize water held in a pervious subsurface stratum (aquifer). Deep wells generally provide more constant and more prolific supplies than do shallow wells.

Artesian wells may be developed when an aquifer outcrops at a surface elevation significantly higher than the ground elevation at the well site. The aquifer is thus pressurized, and water flows from the well without pumpage. A natural artesian well may occur if a fault extends from the aquifer to the ground surface.

Springs occur where the groundwater table outcrops at the surface of the earth. However, the supply available from springs is seldom great enough to serve more than one or two homesteads and is thus usually insignificant in terms of supplying communities. Surface streams may also be fed from the groundwater table, and vice versa. Figure 1 depicts these various conditions.

Well water is usually pumped to a treatment site or into a distribution system by either vertical turbine line shaft pumps or submersible pumps. Economics dictates the selection of one type over the other. In general, at depths greater than 500 ft (150 m) submersible pumps become economically competitive with line shaft pumps. For shallower depths, line shaft pumps are used almost exclusively.

**Effects of Source on Water Quality** Although the quality of water obtained from both groundwater and surface supplies varies greatly according to local climatological, hydrological, and geological conditions, some general comparisons can be made between groundwater and surface supplies. Surface supplies generally contain more bacteria, algae, and suspended solids than do groundwater sources and thus require specific treatment to eliminate the resulting turbidity, colors, odors, and tastes.

Groundwater supplies generally contain few bacteria and in some instances are pure enough for domestic use without chemical treatment. Frequently, however, groundwater supplies contain significant amounts of dissolved minerals. Depending upon the mineral type, the resulting supply may exhibit such characteristics as extreme hardness, toxicity, or undesirable color, odor, or taste. Special treatment such as aeration, lime softening, and disinfection may be required to remove such objectionable characteristics.

## USES OF WATER

**Classifications** History has shown that significant concentrations of population have always occurred where a water supply was readily available. Accordingly, technology has been developed to make full use of the available supply, not only for domestic use but also for public, commercial, industrial, and agricultural consumption.

*Domestic usage* consists of water used for household purposes. The amounts used for such purposes vary with the standard of living of the consumers, the quality of the water, whether metering devices are used, and other factors. Consumption for domestic purposes is generally in the range of 50 to 60 gal per capita per day (gpcd) [190 to 230 liters (lpcd)], which is defined as the total quantity of water used in one calendar year divided by  $(365 \times \text{average number of persons supplied})$ .

*Public usage* includes the water used for such purposes as street cleaning, water for public parks, and supply to public buildings. Such consumption generally amounts to about 10 to 15 gpcd (38 to 57 lpcd).

*Commercial usage* varies according to the number and size of shops and stores in the area served. Attempts have been made to assign commercial consumption on the basis of gallons per day per square foot of floor space. However, the nature of business conducted in commercial installations varies widely, and accurate allocation of specific demands for commercial use must be based on a thorough investigation of the individual establishments.

*Industrial usage* can play a major role in the design of water supply, treatment, and distribution systems. In heavily industrialized areas, industrial usage can account for 30% or more of the total water consumption.

*Agricultural usage* includes the water used for irrigation and for watering livestock. In most localities, irrigation water will not be a factor in system design. However, in semiarid locations where crops rely heavily on irrigation water, consideration must be given to such needs, and a thorough analysis must be made.

**Water Consumption** A necessary element in the design and selection of pumping equipment for water supply projects is the determination of the amount of water required. Population forecasts and estimates of future usage serve as a basis for the design of municipal and urban systems.

The rate of consumption is usually expressed as the average annual usage in gallons per capita per day. Actual average use varies throughout the country, generally from 120 to 200 gpcd (450 to 760 lpcd). In metropolitan areas, an average value of 175 gpcd (660 lpcd) is often used for design purposes.

**Demand and Daily Fluctuations** Water supply systems are subject to wide fluctuations in demand. The rate of consumption varies seasonally, monthly, daily, and hourly. For design purposes, it is essential that a reasonably dependable relationship between certain water use rates be determined from past experience records. The usage and demand rates are as follows:

1. *Average daily demand* may be expressed as gallons (liters) per capita per day or million gallons (liters) per day (the total year's usage divided by 365). The average daily demand rate is generally used as the yardstick by which all other demand rates are measured.
2. *Maximum monthly demand* is the average daily use during the month of greatest consumption. It is determined by dividing that month's total usage by the number of days in the month.
3. *Maximum daily demand* is the total amount of water used during the day of heaviest consumption in the year. Experience shows this demand rate occurs on from three to five consecutive days during the year.
4. *Maximum hourly demand* is the rate of use during the hour of peak demand on the day of maximum demand. This demand rate normally establishes the highest rate of design for distribution systems and "peaking pumpage."

Recording the hourly variations in water consumption over a 24-hour period is no simple undertaking. It involves taking synchronized hourly readings of all pump discharge rates and storage levels and, from these, computing the hourly rate of consumption. Such

recordings of hourly consumption rates made for Dallas are shown in Figure 2 and can be used to establish system design parameters.

**Water Consumption Rates as a Basis of Design** The variations in demand, expressed as a ratio of the average daily demand, must be considered in basic designs of water supply systems.

Figure 3 illustrates graphically the relationship that is characteristic of many water supply demand rates. It also serves to establish percentage ratios for design purposes as follows:

Maximum monthly rate = 155%  $\times$  average daily rate

Maximum daily rate = 186%  $\times$  average daily rate

Maximum hourly rate = 343%  $\times$  average daily rate

Alternately, the design demand rates may be expressed in terms of per capita consumption:

Average daily demand = 175 gpcd (662 lpcd)

Maximum monthly demand = 270 gpcd (1022 lpcd)

Maximum daily demand = 325 gpcd (1230 lpcd)

Maximum hourly demand = 600 gpcd (2270 lpcd)

These demand rates are indicative of water requirements in the southwestern United States and will vary in other regions. Nevertheless, the values shown are reasonable and will assist designers in establishing local criteria. Above all, such values depict the broad range of pumping rates for which equipment must be chosen.

**Variations for Pumping-Time Evaluations** The pumps of most water supply systems must operate continuously throughout the year. Studies are often required to determine operating costs and evaluate equipment. Thus, pumping time in days, which can also be expressed as a percentage of average daily demands, is a useful piece of information in various pumping design problems. Based upon studies made of municipally owned waterworks of various sizes in the southwestern United States, the total pumpage for the year will vary approximately as shown in Table 1.

## PUMPING STATIONS

---

**Pumping Capacity** Determination of the capacity required at a particular pumping station must be based on a thorough analysis of the proposed system. Such factors as the projected average and maximum daily demands, the safe yield of the available supply, and the function of the pumping station in the total system must be considered.

Accurate forecasts of future demands will often establish the design criteria for a pumping station, which should be capable of supplying demands for the area served for many years. Common practice involves sizing the station for anticipated demands for 25 years or more, with initial installation of only enough pumping capacity for 5 to 10 years. Additional capacity can then be added, as directed by future demands, simply by installation of additional pumping units.

Limitations on pumping capacity may be imposed by the yield of the raw water supply. It is sometimes desirable to size pumps to deliver only the safe yield of the source. More often, however, it is practical to impose severe overdrafts on the supply source for short periods of time and to allow the source to refill during sustained periods of low demand. In such cases, pumping capacity may exceed the safe yield of 200% or more, depending on the magnitude of anticipated peak demands and the length of time for which such demands must be satisfied.

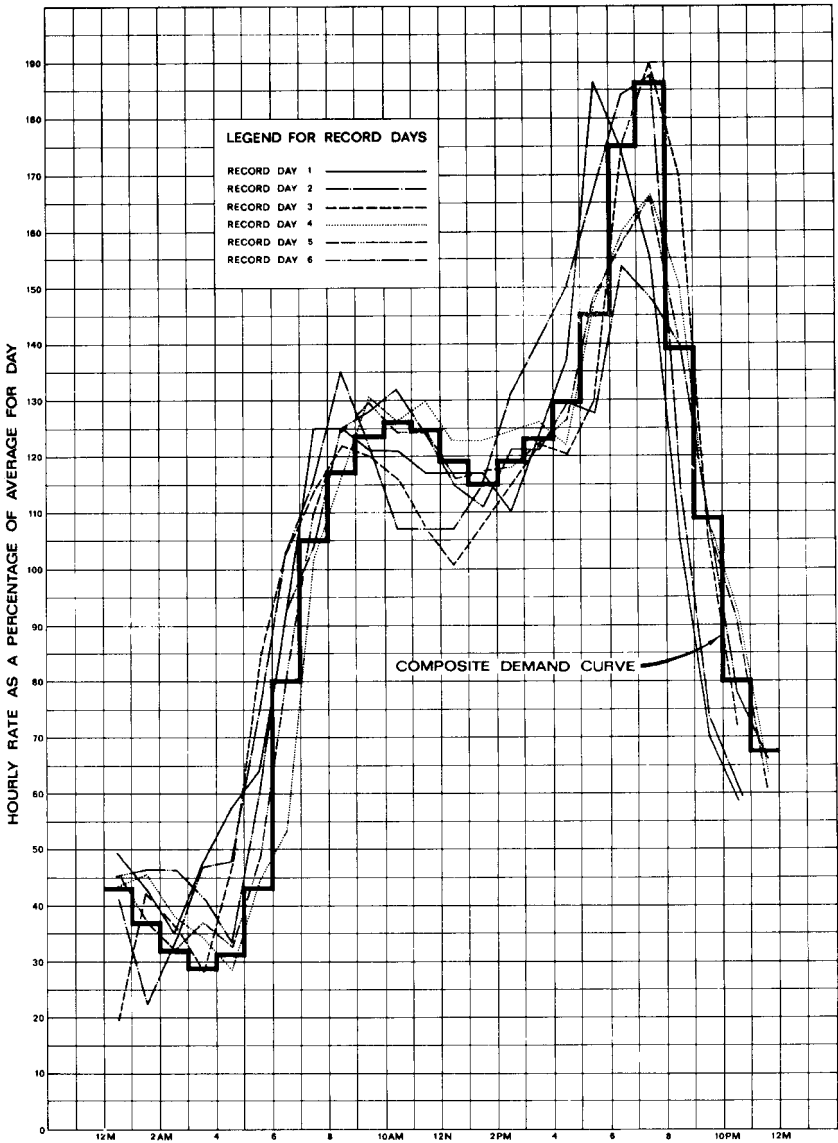


FIGURE 2 Percentage rate of hourly water consumption for Dallas, showing variations on the days of recorded maximum demand and composite demand curve. This information can be used as a basis of system design (URS/Forrest and Cotton).

The function of the pumping station in overall system operation can also affect the determination of required pumping capacities. It is sometimes practical to provide constant-rate pumpage from the source by constructing a balancing reservoir near the treatment site. The balancing reservoir must have ample capacity to permit withdrawal at

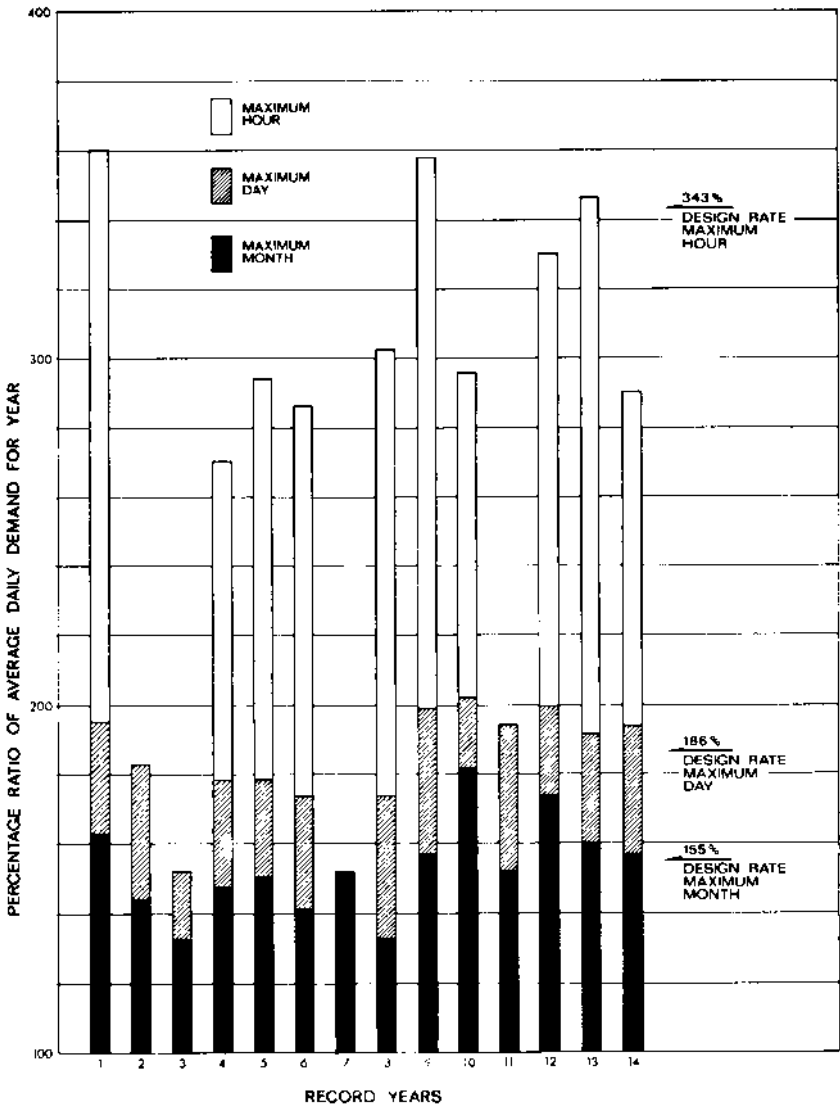


FIGURE 3 Comparison of maximum monthly, daily, and hourly demand rates, expressed as percentage of average daily rate for the year (URS/Forrest and Cotton)

varying rates (in accordance with treated water demands) without overflowing or draining. Since the balancing reservoir is sized for a constant input, the transmission line from the source requires no peaking capacity and the size of the transmission line is thus minimized. This type of operation is thus economically feasible when the savings realized from the reduced size of the transmission line are greater than the cost of constructing a balancing reservoir and variable-rate pumping and transmission facilities for the short distance from the balancing reservoir to the treatment facilities. Accordingly, this operational

**TABLE 1** Number of days of pumpage in year expressed as ratio of average daily demand rate

Demand, % of average daily rate	Days of pumpage per year
190	11
185	14
180	12
165	11
155	13
145	17
135	12
115	27
85	95
75	64
65	89
	365

scheme becomes desirable when the source of supply is located a great distance from the treatment site.

**Selection of Pump Type** The location and configuration of the pumping station and intake structure and the anticipated heads and capacities are the major factors influencing the selection of a specific type of pump. If the pumping station and intake structure are to be located within a surface reservoir, vertical turbine pumps with columns extending down into a suction well are a logical choice.

In many cases, however, the pumping station is located downstream from the dam, with connecting suction piping from the intake structure. In such instances, a horizontal centrifugal pump represents a more logical selection. Horizontal centrifugal pumps of split-case design are commonly used in waterworks because the rotating element can be removed without disturbing suction and discharge piping. Selection of a bottom suction pump (in lieu of side suction) should be considered when possible because the former requires less space on the station floor.

**Effect of Source on Selection of Pump Materials** Although many service conditions are involved in the selection of pump materials, the primary factors that can be related to source of supply are alkalinity and abrasiveness. The alkalinity (or acidity) of a raw water source is reflected by the raw water pH. In general, a pH above 8.5 or below 6.0 precludes the use of a standard bronze-fitted pump (cast iron casing, steel shaft, bronze impeller, wearing rings, and shaft sleeve). The high pH values often associated with groundwater sources then dictate the use of all-iron or stainless steel-fitted pumps.

Abrasiveness, which may result from sand and other suspended matter in a surface water supply, may dictate the selection of stainless steel or nickel-cast iron casing; cast iron, nickel-cast iron, or chrome steel impellers; and stainless steel, phosphor bronze, or Monel wearing rings, shafts, sleeves, and packing glands.

**Suction and Discharge Piping** In order to minimize head loss and turbulence, the use of long-radius bends in both suction and discharge piping is strongly recommended. American Water Works Association (AWWA) approved double-disk gate valves with outside screw and yoke or AWWA-approved butterfly valves of the proper classification are recommended for use as isolation valves in the pump suction and discharge piping. Additionally, a check valve should be provided on the discharge side of the pump to prevent backflow through the pump upon shutdown or power failure. Many types of check valves have been used satisfactorily in such applications. However, the regulated opening and closing times afforded by cone valves, combined with excellent throttling characteristics,



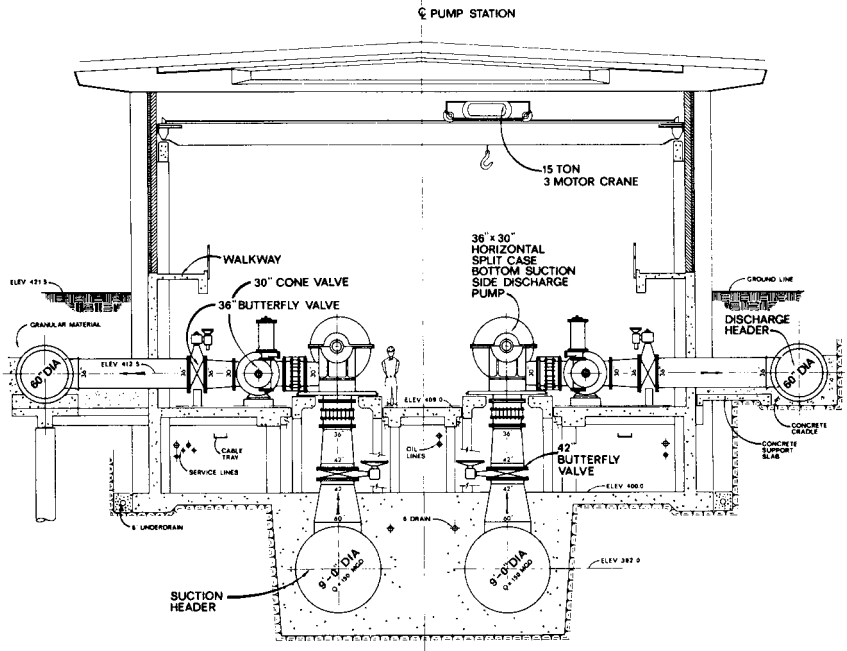


FIGURE 4 Typical section of the Forney raw water pumping station in Dallas, showing pump suction and discharge piping (1 in = 2.54 cm; 1 ft = 0.3048 m) (URS/Forrest and Cotton)

have proved effective in minimizing surges and should be considered for pump check service if economically feasible.

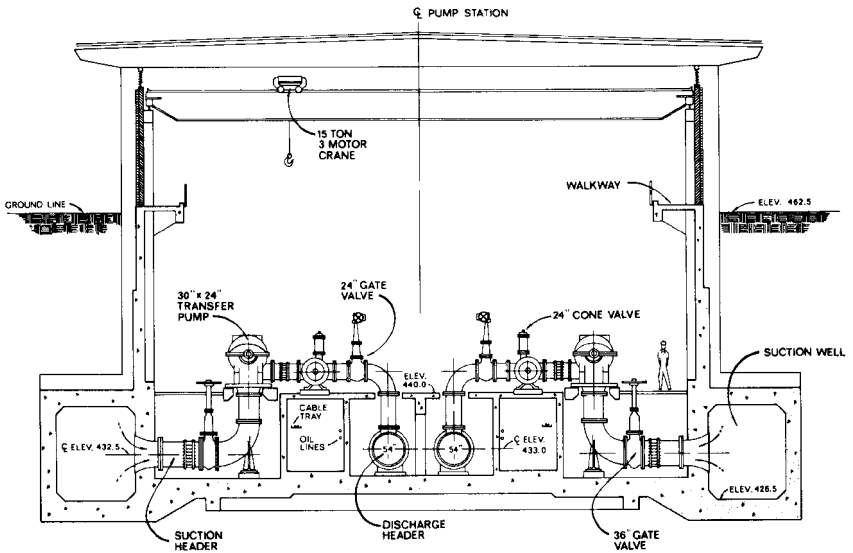
Manifolding of suction and discharge headers is common practice in the design of pumping stations because parallel operation can be readily achieved with such an arrangement. Suction headers may be located directly below the pumps (Figure 4) or along the outside wall of the pump station (Figure 5), depending on the location of the intake structure and the configuration of the suction piping. Interconnection of discharge headers (Figure 6) provides additional system flexibility and added protection in the event of line breakage.

**Pump Drivers** The waterworks industry has evolved to the point of almost exclusive use of electric motors as pump drivers. Diesel or gasoline engines may be used as emergency drivers or as the primary drivers where reliable electric power is not available. However, the high costs of continuous operation and the limitations of rotative speed preclude the use of diesel or gasoline drivers in most installations.

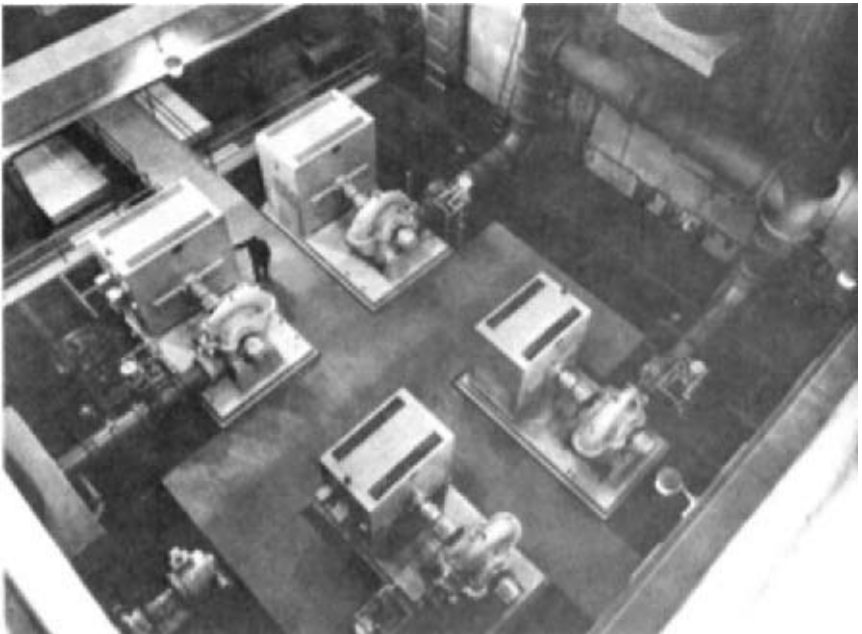
Although some dc motors are used in the waterworks industry, the great majority of electric motors used as pump drivers are ac motors of the squirrel-cage-induction, wound-rotor, or synchronous type. Hydraulic or magnetic variable-speed devices can be used in conjunction with the pump driver to vary pumping rates in accordance with demand.

**System-Head Curves** The capacity of a pumping installation cannot be determined without an accurate determination of the head requirements of the system. Consequently, a system-head curve must be derived, depicting calculated losses through the system for various pumping rates. The construction of a system-head curve must be based upon a logical sequence of determinations of the various components of system losses.

A preliminary sketch or schematic should be derived, showing the configuration and size of suction and discharge piping, including all pipe, valves, and fittings.



**FIGURE 5** Typical section of the high-service pumping station of the East Side water treatment plant in Dallas (1 in = 2.54 cm; ft = 0.3048 m) (URS/Forrest and Cotton)



**FIGURE 6** Dallas Iron Bridge 100-mgd ( $3.78 \times 105 \text{ m}^3/\text{day}$ ) raw water pumping station, showing layout with bottom-suction, side-discharge pumping units (URS/Forrest and Cotton)

**FRICTIONAL LOSSES** Frictional loss in the discharge piping can be determined for various pumping rates from the formula:

$$\text{In US units} \quad h_f = KQ^{1.85} \quad (1a)$$

$$\text{In SI units} \quad hf = 2.618 \times 10^{-5} KQ^{1.85} \quad (1b)$$

where  $h_f$  = head loss, ft (m)

$K$  = a constant depending on pipe size and friction factor  $C$

$Q$  = flow, mgd ( $\text{m}^3/\text{h}$ )

Equation 1 is a modification of the basic Hazen-Williams formula for the special case of circular pipes flowing full. Values of  $10^5 K$  for various pipe sizes and friction factors are listed in Table 2. Common practice has been to design systems on the basis of  $C = 100$ . However, investigations for the Dallas Water Utilities have indicated that a regulated cleaning program for pipelines can result in sustained values of  $C$  as high as 135 or 140. Accordingly, consideration should be given to providing for periodic cleaning of pipelines so the initial design capacity of the pumping units can be sustained.

To demonstrate the use of Eq. 1, assume that it is desired to compute the head losses due to pipe friction as a result of pumping at a rate of 30 mgd ( $4730 \text{ m}^3/\text{h}$ ) through 1050 ft (320 m) of 36-in diameter (914.4-mm) pipe having a friction factor of 130. From Table 2,  $10^5 K = 0.610$  or unit  $K = 0.00000610$ :

$$\text{Segmental } K = 0.00000610 \times 1050 = 0.006405$$

$$\text{In USCS units} \quad Q^{1.85} = 30^{1.85} = 540.3$$

$$h_f = 0.006405 \times 540.3 = 3.46 \text{ ft}$$

$$\text{In SI units} \quad Q^{1.85} = 4730^{1.85} = 6.29 \times 10^6$$

$$h_f = 2.618 \times 10^{-5} \times 0.006405 \times 6.29 \times 10^6 = 1.06 \text{ m}$$

Entrance and exit losses and losses through valves and fittings can be calculated from the data in Section 8.1.

**STATIC HEAD AND PRESSURE DIFFERENTIAL** In computing total system head, consideration must be given to the effects of static head and pressure differential. Static head can be calculated simply from the difference in elevation between supply level and discharge level, and differential pressure can be calculated from the difference between terminal pressure and suction pressure.

**PUMP CHARACTERISTIC CURVES** The shape of a centrifugal pump curve must be considered in selection of a specific pump. If, for example, the water level at the source of supply or at the point of discharge is subject to wide variation, a pump with a steep characteristic curve near the design point should be selected to minimize the effects of head variations on pump capacity. Additionally, the pump shutoff head (or head of impending delivery) must exceed the static head to ensure that the pump will operate upon opening of the discharge valve.

**NET POSITIVE SUCTION HEAD** As a final step in selection of a specific pump for a particular application, suction conditions should be investigated to determine the net positive suction head (*NPSH*) available. Failure to meet the *NPSH* requirements of the pump selected will result in cavitation of the pump impeller and very low pumping efficiency.

**TOTAL SYSTEM HEAD** The summation of all components of system head, as calculated for various flows, results in a graphical plot of the system-head curve (Figure 7). To determine the capability of a specific centrifugal pump operating under system conditions, the pump characteristic curve should be superimposed on the system-head curve. The intersection of the two curves then represents the capacity that the specific pump can deliver. The construction of system-head curves is further discussed in Section 8.1.

TABLE 2 Computed valued of  $10^5K$  for use in Eq. 1

Pipe diameter, in.	Hazen-Williams $C$ value								
	70	80	90	100	110	120	110	135	140
6	11,800	9,240	7,420	6,100	5,100	4,350	3,750	3,590	3,280
8	2,900	2,270	1,823	1,500	1,240	1,070	924	881	805
10	982	767	617	507	425	362	312	298	272
12	404	315	253	209	175	149	128.5	122.6	112.1
14	190	149	119.7	98.4	82.5	70.4	60.5	57.8	52.9
16	99.6	77.8	62.6	51.6	43.3	36.8	31.6	30.3	27.7
18	56.1	43.9	35.2	29.0	24.3	20.7	17.84	17.04	15.6
20	33.6	26.2	21.1	17.33	14.53	12.4	10.67	10.17	9.30
21	26.4	20.7	16.6	13.67	11.47	9.77	8.43	8.05	7.35
24	13.8	10.3	8.68	7.13	5.99	5.09	4.39	4.19	3.83
27	12.4	6.08	4.89	4.02	3.37	2.87	2.47	2.36	2.16
10	4.66	3.64	2.91	2.41	2.02	1.717	1.48	1.412	1.291
51	2.94	2.29	1.964	1.516	1.269	1.081	0.933	0.890	0.814
16	1.92	1.50	1.206	0.993	0.832	0.708	0.610	0.583	0.534
19	1.298	1.016	0.816	0.670	0.563	0.480	0.413	0.395	0.361
42	0.906	0.706	0.570	0.469	0.392	0.334	0.287	0.276	0.251
45	0.646	0.504	0.406	0.334	0.280	0.238	0.206	0.1964	0.1796
48	0.462	0.379	0.290	0.239	0.200	0.1702	0.1470	0.1401	0.1280
51	0.352	0.275	0.221	0.1816	0.1522	0.1296	0.1119	0.1067	0.0975
54	0.266	0.208	0.1673	0.1377	0.1152	0.0982	0.0848	0.0807	0.0738
57	0.204	0.160	0.1285	0.1056	0.0886	0.0753	0.0650	0.0621	0.0567
60	0.1594	0.1244	0.1000	0.0823	0.0691	0.0587	0.0507	0.0484	0.0442
63	0.1256	0.0982	0.0789	0.0650	0.0545	0.0464	0.0400	0.0382	0.0349
66	0.1000	0.0785	0.0630	0.0518	0.0434	0.0370	0.0319	0.0304	0.0278
69	0.0805	0.0630	0.0507	0.0417	0.0349	0.0298	0.0256	0.0245	0.0224
72	0.0655	0.0511	0.0412	0.0339	0.0284	0.0242	0.0209	0.01991	0.01820
75	0.0538	0.0414	0.0339	0.0278	0.0233	0.01982	0.01710	0.01632	0.01493
78	0.0444	0.0347	0.0279	0.0229	0.01924	0.01637	0.01413	0.01348	0.01231
81	0.0314	0.0289	0.0232	0.01906	0.01600	0.01360	0.01173	0.01121	0.01024
84	0.0309	0.0242	0.01942	0.01600	0.01340	0.01141	0.00984	0.00939	0.00859
90	0.0222	0.01730	0.01390	0.01143	0.00957	0.00816	0.00704	0.00672	0.00614
96	0.01614	0.01262	0.01013	0.00834	0.00700	0.00596	0.00513	0.00491	0.00448
102	0.01200	0.00939	0.00756	0.00621	0.00520	0.00444	0.00381	0.00365	0.00334
108	0.00910	0.00711	0.00572	0.00471	0.00395	0.00336	0.00289	0.00276	0.00253
120	0.00545	0.00426	0.00343	0.00283	0.00235	0.00200	0.00173	0.00165	0.00151

Note: In Eq. 1a,

$$K = (1594/C)^{1.85} (L/d^{4.87}) / (1/0.446)$$

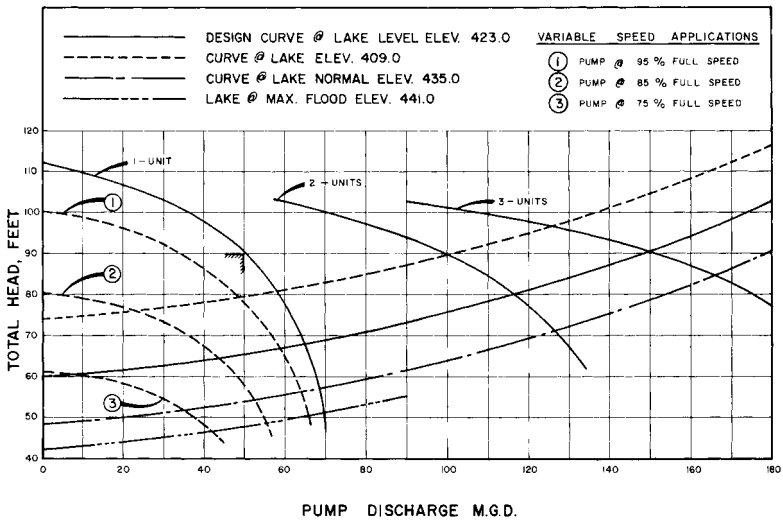
$C$  = Hazen-Williams coefficient of pipe friction

$D$  = pipe length, ft;  $10^5K$  values are for  $L = 1.0$  ft and must be multiplied by true line length to determine line segmental  $K$

$d$  = pipe diameter, in

1 in = 25.4 mm

**Parallel and Series Operation** The installation of multiple pumping units operating in parallel is common practice in the waterworks industry because, with proper design and regulation, it permits the most efficient use of pumping facilities and allows smooth transitions in pumping rates as demand fluctuates. This type of operation is particularly adaptable to pumpage from treatment facilities into a distribution system but is also applicable to raw water pumpage, which is generally required to match treated water pumpage. Special care must be taken in sizing the individual pumping units to ensure efficient operation and to prevent units from operating significantly above or below design rates during parallel operation. The principle upon which design must be based is that *total station discharge may be determined by adding the individual pump discharges associated with any particular head*. Obviously then, as additional pumps are placed in operation, the station flow will increase. However, because the system-head curve rises with



**FIGURE 7** System-head curve for the Forney raw water pumping station of Dallas (1 ft = 0.3048 m; 1 mgd = 157.7 m<sup>3</sup>/h; elev. in ft  $\times$  0.5048 = elev. in m) (URS/Forrest and Cotton)

increasing flow, the operation of two identical pumps in parallel will not produce a discharge equal to twice the capacity of one pump. As more pumps are placed in operation, the incremental increase in pumping capacity becomes smaller.

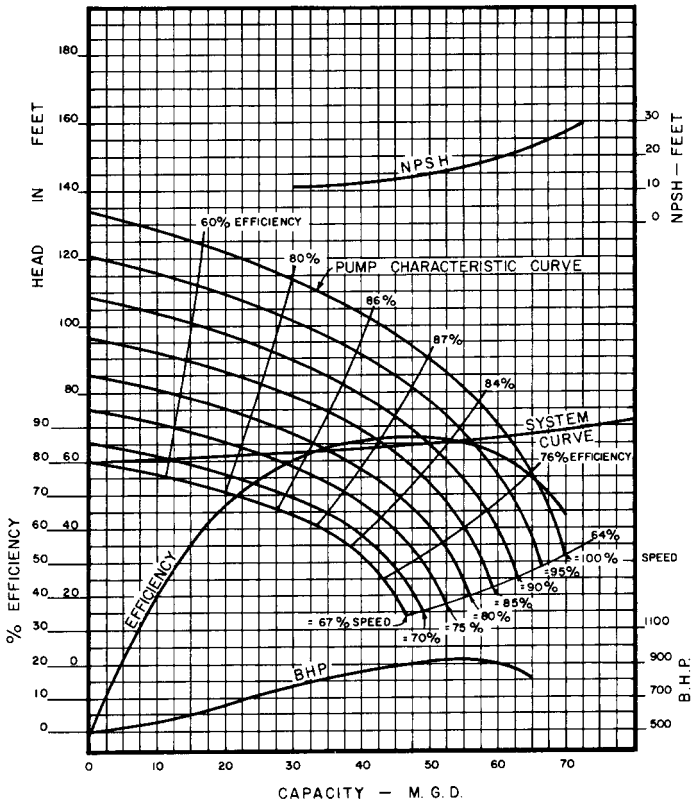
It should be noted that, when only a portion of the pumps are in operation (total station flow is less than design capacity), the total system head is reduced and the individual pumping units are thus operating at a rate exceeding the design capacity.

If flows are increased substantially past the design point, the *NPSH* available may become inadequate and cavitation may occur. Additionally, the possibility of overloading the pump driver is introduced, particularly in pumps designed for high heads. In selecting a pumping unit, it is therefore necessary to check conditions at runout capacity (the maximum discharge and lowest head anticipated) in order to ensure proper pump operation.

The undesirable effects of operating a pump at capacities lower than design flow are similar to those resulting from overpumping, but for different reasons. Low discharge rates result in recirculation through the pump, causing cavitation, vibration, and noise. Moreover, the radial force on the impeller increases substantially, thus increasing the stress on the shaft and bearings (to an even greater extent than would result from overpumping). Drivers of pumps designed for low heads may be subjected to overload at low capacities (and thus high heads).

In determining pumping capacities for series operation, *heads are added*. Thus two identical pumps with capacity of 30 mgd (4730 m<sup>3</sup>/h) at 200 ft (60 m) of system head would, if placed in series, discharge 30 mgd (4730 m<sup>3</sup>/h) at 200 ft (60 m) of system head. This type of operation is frequently employed in raw water pumping stations in the form of multi-stage, vertical turbine pumps and is frequently utilized to boost pressures in a distribution system.

**Variable-Speed Applications** Installation of two or more variable-speed pumping units will allow gradual increase or decrease of station discharge as dictated by demand. When the required discharge is less than the capacity of two pumps, the variable-speed units may be operated in parallel. Moreover, the installation of two variable-speed units permits operation at flows in excess of the minimum allowable flow and ensures satisfactory efficiency under all conditions. Figure 8 typifies the relationships between head, capacity,



**FIGURE 8** System-head curves for variable-speed operation for the Forney raw water pumping station in Dallas (1 ft = 0.3048 m ; 1bhp = 0.746 bkW; 1 mgd = 157.7 m<sup>3</sup>/h) (URS/Forrest and Cotton)

and efficiency at varying speeds. Typical procedure for an installation with two variable-speed units is as follows:

1. If station flow is less than the capacity of one pump, one variable-speed unit is operated.
2. If station flow is between one and two times the capacity of a single unit, both variable-speed units are operated (in lieu of operating one unit at full speed and the other at a speed less than that required to produce minimum allowable flow).
3. If station flow is more than two times the capacity of a single unit, the two variable-speed units are operated, along with as many constant-speed units as are required to ensure operation of all pumps at speeds that will produce flows exceeding minimum requirements.

### **USES OF PUMPS AT WATER TREATMENT PLANTS**

Pumps are an integral part of virtually every water treatment plant in existence and have a variety of uses, including low-lift service, coagulant feed, carbon slurry transfer and feed,

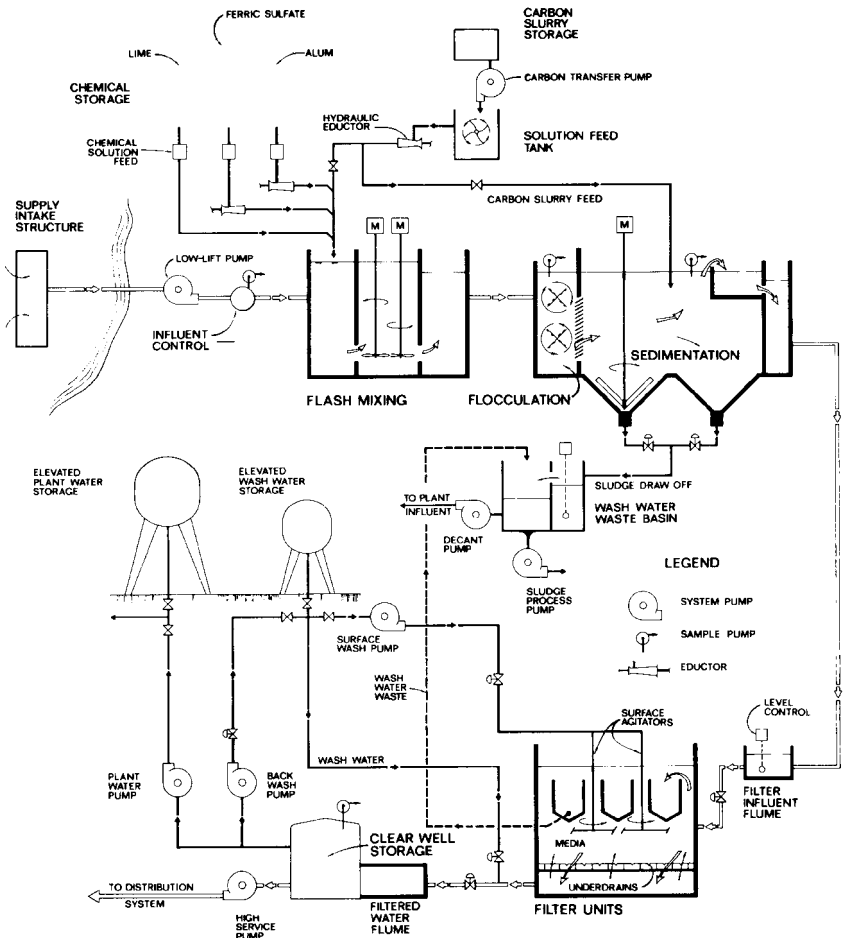


FIGURE 9 Typical flow diagram of water treatment plant, including raw water supply

fluoride feed, delivery of samples from selected points to the chemical laboratory, plant water supply, wash water supply, surface wash supply, and high service pumpage to the distribution system (Figure 9).

**Low-Lift Pumps** Low-lift pumps, located at either the source or the treatment site, are often outdoor, weatherproof vertical pumps (Figure 10). They may also be horizontal centrifugal pumps housed in a separate pumping station. Head and capacity requirements are as discussed previously.

**Coagulant Feed Pumps** Pumps used in chemical feed applications are usually not centrifugal because of the kinds of materials handled. More often, chemicals are fed by a jet pump or hydraulic eductor that utilizes a moving stream of water to create a vacuum at the suction port of the eductor. This type of pump has no moving parts and is thus adaptable to the feeding of coagulants such as alum or ferric sulfate in solution. A constant-level solution tank is often used to maintain a constant head on the eductor suction. The



**FIGURE 10** Raw water pumping station for North Texas Municipal Water District, showing vertical turbine pumps with variable-speed drives (Flowsolve Corporation)

eductor capacity is then a function of water supply pressure and frictional loss in the feed lines. Eductors are normally rated according to suction capacity, which must be added to the amount of flow contributed by the motive fluid in calculating head losses through the feed system. The manufacturer's literature should be consulted to determine the water supply requirements for various sizes of eductors.

**Carbon Slurry Pumps** Treatment plants that receive raw water from surface sources often require the addition of activated carbon to combat taste and odor problems caused by suspended material and microorganisms carried into the supply by floodwaters. Consequently carbon must be stored in ample quantities to supply immediate needs. The activated carbon is often transferred from storage tanks to a constant-level solution tank in the form of a slurry. Progressing cavity-type pumps equipped with variable-speed drives are suitable for this transfer service, provided the proper construction materials are selected. The range of capacities required is equal to the difference between minimum and maximum carbon feed rates, and discharge head can be calculated as for any pumping system. However, selection of operating speed and power requirements must be based on estimates of the abrasive and viscous characteristics of the slurry.

**Fluoride Pumps** The addition of hydrofluosilicic acid to drinking water is achieving growing acceptance in the United States as an effective preventative of tooth decay. Pumps used for addition of this material should be positive displacement, mechanical diaphragm, metering pumps constructed of special materials, such as Kralastic, Fenton, and Teflon. A relief valve should be installed on the discharge line to protect the pump in the event of a line blockage.

Diaphragm pumps operate on the principle of the linear motion of a flexible diaphragm, which pulls the solution through an intake port during the backward stroke and forces solution out the discharge port on the forward stroke. Feed rate can be varied by adjusting the stroke length or by a multistep pulley belt-connected to the motor driver. Hydrofluosilicic acid is usually supplied as a slurry that is 20 to 30% hydrofluosilicic acid. Of this acid, 79% is in the form of fluoride ion. In sizing the fluoride feed pumps, consideration must be given to the following factors:



1. Difference between the fluoride ion content of the raw water and that desired in the finished water
2. Strength of the slurry
3. Specific gravity of the slurry

For example, assume that the fluoride ion content of the raw water is 0.3 parts per million (ppm) and the desired concentration in the treated water is 0.8 ppm; that the slurry is 20% hydrofluosilicic acid with a specific gravity of 1.22; and that the plant raw water inflow is 100 mgd (15,800 m<sup>3</sup>/h). The required dosage is then

$$\frac{0.8 - 0.3}{(0.79)(0.20)(1.22)} = 0.192 \text{ ppm of slurry}$$

and the amount of slurry needed is

in USCS units  $0.192 \text{ ppm} \times 100 \text{ mgd} \times 8.34 \text{ lb/gal} = 160 \text{ lb/day}$

in SI units  $0.192 \text{ ppm} \times 15,800 \text{ m}^3/\text{h} \times 10^{-6} \times 24 \text{ h/day} \times 998.3 \text{ kg/m}^3 = 72.7 \text{ kg/day}$

Head losses to the point of application can be calculated (with allowances for the viscosity of the slurry) and the proper feed rate accomplished by adjustment of the stroke length. A diaphragm pump is capable of providing a repeatable accuracy of  $\pm 1\%$ , a desirable characteristic in light of the fact that excess fluoride in drinking water can produce harmful rather than beneficial effects on the teeth.

**Sampling Pumps** Small-capacity centrifugal pumps are generally used for delivery of samples from various points in the plant to the chemical laboratory for analysis. Capacities required are generally in the vicinity of 5 to 10 gpm (1.1 to 2.3 m<sup>3</sup>/h). The required discharge head can be determined from a schematic layout of the suction and discharge piping, with provision for some 10 to 15 lb/in<sup>2</sup> (70 to 100 kPa) pressure at the chemical laboratory faucet. Head losses through the system are computed as in any pumping system, and such computations are simplified somewhat by the fact that no interconnections are involved; that is, each sample pump must have a separate discharge line to the chemical laboratory.

**Plant Water Pumps** Water used for various purposes throughout the treatment plant is usually taken from the treated water at the end of the process. Such water may be pumped back directly into the plant water system or to an elevated storage tank that supplies the head required for adequate pressures throughout the plant. In either case, a thorough study of the plant water system is necessary to determine the amount of water required. The plant water tank can be provided with automatic start and stop controls based on the water level in the tank to prevent complete draining or overflowing. Allowances should be made to ensure that the tank is sufficiently elevated to provide ample pressures at water-consuming devices. Plant water pumps will generally be of horizontal split-case construction and must be capable of filling the elevated tank at rates determined from analysis of the plant water system.

**Wash Water Pumps** The procedure for selecting wash water pumps is much the same as that for plant water pumps. An elevated wash water tank should be sized large enough to permit backwashing of one filter at a time and should be elevated as necessary to provide the required flows through the wash water piping system. Required backwash rates vary from about 15 to 22.5 gpm/ft<sup>2</sup> (37 to 55 m<sup>3</sup>/h/m<sup>2</sup>) of filter surface area. In determining head losses from the elevated tank through the filters, consideration must be given not only to the head losses in piping, valves, and fittings, but also to the head losses in the filter underdrain system, which may range from 3 to 8 ft (0.9 to 2.4 m) at a backwash rate of 15 gpm/ft<sup>2</sup> (37 m<sup>3</sup>/h/m<sup>2</sup>), depending on the under-drain system installed and the filter bed. The wash water tank should be sized to allow backwashing of one filter for approximately 10 min and should be equipped with controls for automatically starting and stopping the wash water pumps at predetermined lev-

els. The required pumping capacity depends on the estimated frequency and rate of backwashing.

Wash water pumps may also be used to supply water directly to the backwash piping system. The head required in such cases is that needed to overcome all losses in the wash water piping, underdrain system, and filter bed, and the capacity should equal the maximum backwash rate. An air release valve, check valve, and throttling valve should be provided on the discharge side of the wash water pump, and standby service is highly recommended.

Because the wash water pumps generally use treated water from clear well storage, horizontal centrifugal pumps should be used only when positive suction head is available. Otherwise, a vertical pump unit may be suspended in the clear well.

**Surface Wash Pumps** Manufacturers of rotary agitators for surface wash systems generally specify a minimum pressure for proper operation of their equipment. This pressure [generally from 40 to 100 lb/in<sup>2</sup> (280 to 690 kPa)] must be added to the system piping losses in determining head requirements for surface wash pumps. The required discharge may vary from 0.2 to 1.5 gpm/ft<sup>2</sup> (0.5 to 3.7 m<sup>3</sup>/h/m<sup>2</sup>) of surface area, depending on the supply pressure, size, and type of agitator supplied.

**High-Service Pumps** High-service pumps at a water treatment plant are those pumps that deliver water to the distribution system. The term *water distribution system* as used herein is defined as embodying all elements of the municipal waterworks between the treatment facilities and the consumer. The function of the distribution system is to provide an efficient means of delivering water under reasonable pressure in volumes adequate to meet peak consumer demands in all parts of the area served.

High-service pumps may be of either vertical or horizontal construction, depending on the required capacity and the design and configuration of treated water storage facilities from which the pumps take suction. The high-service pumping station often houses the plant water and wash water pumps in addition to the high-service pumps because all such pumps utilize treated water to perform their required services (Figure 11).

Operating conditions in the distribution system play an important role in the determination of high-service pump capacities. In small municipalities, for example, it may be possible to pump from the treatment plant at a constant rate equal to the average daily demand and to supply peak demands from elevated storage tanks throughout the system. However, as systems become larger, the need for variable-rate pumping from the treatment plant increases. If sufficient storage is available in the distribution system for supplying peak hourly demands, it may be possible to provide variable-speed high-service pumps with total capacity equal to the maximum capacity of the treatment plant and to supply hourly peaks from storage. However, inasmuch as peak hourly demands may be two or more times as great as the peak daily demand and may be sustained for several hours, the required system storage for such operation can exceed 30% of the maximum daily demand. In very large systems, provision for this amount of storage is simply impractical. It may then become necessary to design treatment facilities for capacities in excess of the maximum daily demands and to supply only a portion of the peaking water from storage.

In any event, as distribution systems become larger, variable-speed pumping becomes more desirable and development of a system-head curve becomes more complex. In many cases, pumpage from treatment plants during off-peak hours exceeds pumpage during peak hours because storage tanks must be filled during off-peak hours. System-head curves must be derived for each of the previous conditions and also for a third condition, which represents those periods when storage tanks are full but are not being utilized to supply demands. Typical system-head curves for all three conditions are shown on Figure 12. Only a thorough analysis of the entire distribution system can provide the data necessary for the proper selection of high-service pumps.

## **BOOSTER PUMPS IN DISTRIBUTION SYSTEMS**

---

In order to maintain distribution system pressures within the desirable 40- to 90-lb/in<sup>2</sup> (275- to 620-kPa) range, booster pumps may be required at various locations, as dictated

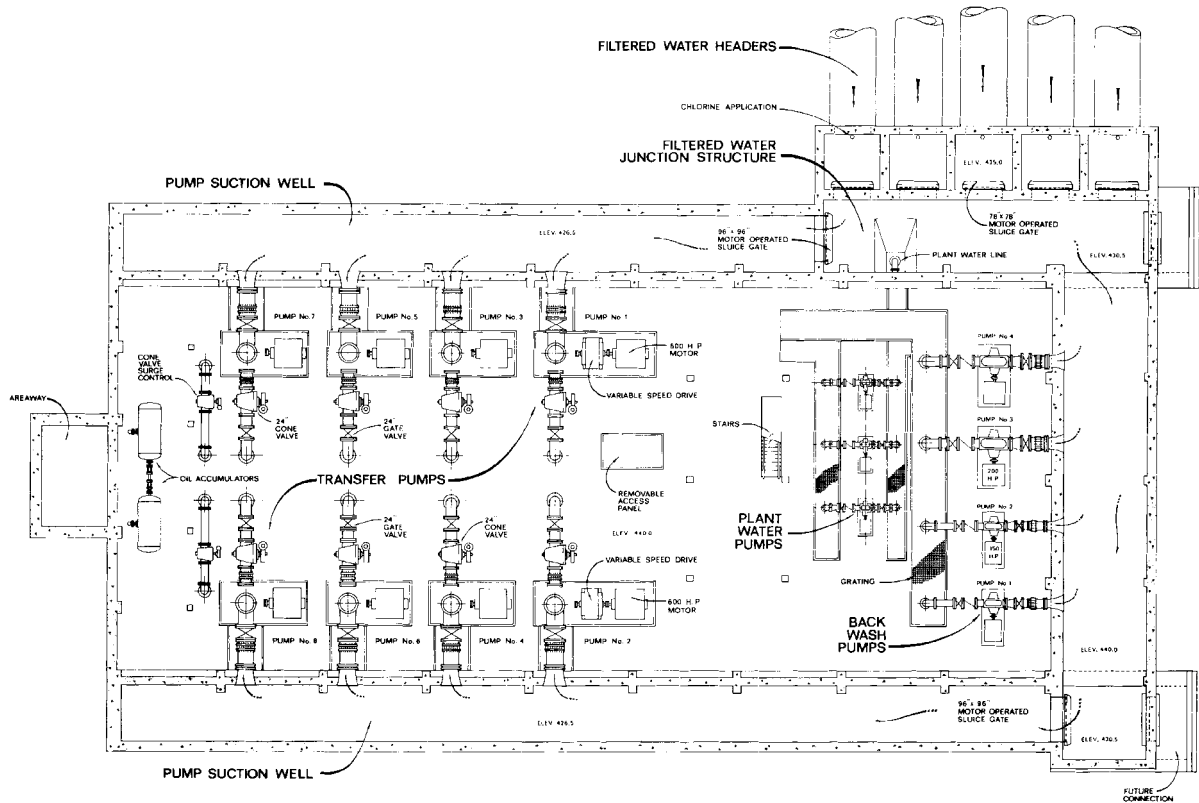


FIGURE 11 Plan of the high-service pumping station in the East Side water treatment plant, Dallas (1 in = 2.54 cm; 1 ft 0.3048 m) (URS/Forrest and Cotton)

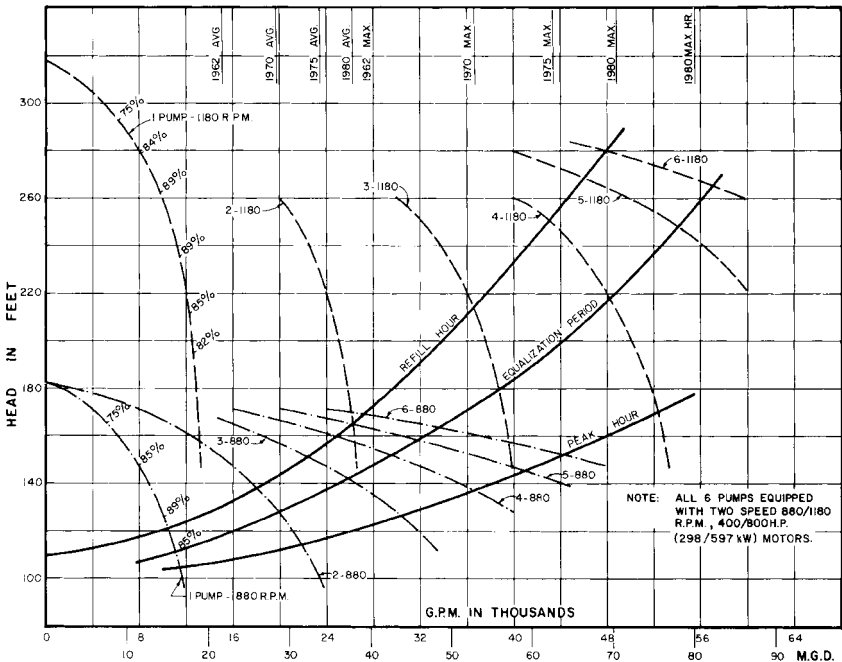


FIGURE 12 Typical system-head curves for high-service pumpage to water distribution system (1 ft = 0.3048 m; 1 gpm = 0.227 m<sup>3</sup>/h)

by topographical conditions and system layout. Booster stations may include in-line vertical or horizontal pumps connected directly to the pipeline or separate storage reservoirs and pumps. The latter method is preferred but is not always practicable because of land requirements for the storage reservoir.

In-line booster pumps should be sized to match the capacities of incoming pipelines and should be capable of supplying the additional head required to increase pressures to desirable ranges in the affected area of the distribution system. Determination of discharge head must take into account the pressure on the suction side of the pump as well as static head, frictional losses, and desired residual pressure on the discharge side.

Many water utilities refuse to accept in-line pumps as satisfactory for booster service and require construction of a pressure-equalizing storage reservoir. Horizontal or vertical booster pumps then take suction from the storage reservoir and return water at higher pressures to the mains. Pressure switches or floats automatically start and stop the booster pumps and thus eliminate the need for continuous attendance.

## GROUNDWATER WELLS

**Site Selection** Foremost among the factors that must be considered in selection of a site for a proposed well are local regulations governing proximity to such potential contaminants as cesspools, privies, animal pens, or abandoned wells. Also to be considered is the effect on adjacent wells—if wells are located too close together, excessive head losses may result.

**Types of Pumps Used** The two basic types of pump used in groundwater wells are vertical turbine, line shaft pumps, and submersible pumps. The vertical turbine pump consists of three basic components: the driving head, the column-pipe assembly, and the bowl assembly. The driving head is mounted above ground and consists of the pump discharge elbow, the motor support, and the stuffing box. The column-pipe assembly (consisting of shaft, bearings, and bearing retainers) and the bowl assembly (consisting of a suction head, impeller or impellers, discharge bowl, and intermediate bowl or bowls) are suspended from the driver head. Use of multiple bowls and impellers results in a form of series operation and permits pumpage against very high heads.

The submersible pump utilizes a waterproof electric motor located below the static level of the well to drive a series of impellers and produce a series operation similar to that of a line shaft pump. However, the length of shafting required is greatly reduced, and thus the shaft losses and total thrust are minimized. As a result, the submersible pump becomes economically competitive with the line shaft pump at great depths.

Air-lift pumps, which operate on the principle that a mixture of air and water will rise in a pipe surrounded by water, may be used in some cases. Such pumps are easy to maintain and operate and can be used in a crooked well or with sandy water. However, they are relatively inefficient (usually 30 to 50%) and allow very little system flexibility.

Reciprocating pumps are also used in some cases where small capacities are required from deep wells. Such pumps can be driven by electric motors or windmills, but they are generally noisy and are more expensive than centrifugal pumps.

**Determining Pump Capacity** The capacity of any well is dependent on such factors as screen size, well development, aquifer permeability, recharge of groundwater supply from rainfall and streams, and available head. The basic procedure used in sizing a pump for well service involves drilling the well and performing a test operation. First the static head, or elevation of the groundwater table prior to pumping, is determined. Water is then pumped at various rates and the drawdown associated with each pumping rate determined. A plot of drawdown versus pumping rate can then be derived. Pumping rate is usually measured by a weir, orifice, or pilot tube, and drawdown is determined with a detector line and gage or with an electric sounder.

From the test data and from a preliminary layout of discharge piping, a system-head curve can be derived, with drawdown added to frictional losses for each pumping rate. The pump characteristic curve can then be superimposed on the system-head curve to determine the capacity that can be attained with a specific pump. It should be noted that pump curves for line shaft pumps are based on the results of shop tests, which do not allow for column frictional or line shaft and thrust losses. Consequently, the laboratory characteristic curve for any line shaft pump must be adjusted to field conditions.

Field pumping head can be determined by subtracting column frictional losses from the laboratory head. Field brake horsepower (brake kilowatts) is determined by adding shaft brake horsepower (brake kW), which depends on shaft diameter and length, and on rotative speed, to laboratory brake horsepower (brake kW). Field efficiency is determined from the formula

$$\text{In USCS units} \quad \text{Field efficiency} = \frac{\text{gpm} \times \text{field head in feet}}{3960 \times \text{field brake horsepower}}$$

$$\text{In SI units} \quad \text{Field efficiency} = \frac{\text{m}^3/\text{h} \times \text{field head in meters}}{367.5 \times \text{field brake kW}}$$

Because thrust loads cause additional losses in the motor bearing, it is necessary to determine the additional power required to overcome thrust losses. Total thrust load is equal to the sum of the shaft weight and the hydraulic thrust (which varies with laboratory head for any particular impeller), and losses due to thrust amount to approximately 0.0075 hp/100 rpm/1000 lb (0.00126 kW/100 rpm/1000 N) of thrust. Motor efficiency is then calculated by dividing the motor's full load power input (without thrust load) by the sum of full load power input and loss due to thrust. Overall efficiency then equals the product of field efficiency and motor efficiency.

As a result of the efficiency losses produced by shaft weight and length in line shaft pumps, it is usually more economical to use a submersible pump at depths of more than about 500 ft (150 m). Sizing a submersible pump requires calculations similar to those for a line shaft pump. However, the submersible pump installation requires a check valve in the column pipe, which must be considered in the determination of frictional losses. Moreover, the efficiency losses resulting from the motor cable (expressed as a percentage of input electric power) must be considered in determining overall efficiency, which can be calculated from the formula:

$$\text{Overall efficiency} = \frac{\text{water power} \times (\% \text{ motor efficiency} - \% \text{ cable loss})}{\text{shop brake power} \times 100}$$

where

$$\text{in USCS units} \quad \text{Water power in hp} = \frac{\text{gpm} \times \text{field head in feet}}{3960}$$

$$\text{in SI units} \quad \text{Water power in kW} = \frac{\text{m}^3\text{h} \times \text{field head in meters}}{367.5}$$

Cable size must be selected on the basis of motor power and motor input amperes, voltage, and cable length.

**Well Stations** A typical well station generally includes a small building for housing the pump, pump controls, metering and surge-control facilities, and chemical feed equipment. Submersible pumps do not require a pump house for protection, but if pump controls or chemical feed equipment are provided, an enclosure of some type is required. Because well water supplies are often pumped directly into the distribution system, a differential producer is usually installed for metering. Moreover, chemicals may be added at the well station to minimize corrosion, control bacteria, decrease hardness, and inject fluorides into the water supply. Surges are usually controlled by installation of a surge valve in the pump discharge line. Controls may also be installed to permit starting and stopping of the pump from remote central locations and to provide for measurement and control of well drawdown.

## FURTHER READING

---

Fair, G. M., Geyer, J. C., and Okun, D. A. *Water and Wastewater Engineering*, Wiley, New York, 1968.

Karassik, I. J., and Carter, R. *Centrifugal Pumps: Selection, Operation, and Maintenance*. McGraw-Hill, New York, 1960.

Messina, J. P. "Operating Limits of Centrifugal Pumps in Parallel." *Water and Sewage Works*. 1969, p. R-79.

Singley, J. E., and Black, A. P. "Water Quality and Treatment: Past, Present and Future." *Journal AWWA*. 64(1):6 (1972).

Texas Water Utilities Association. *Manual of Water Utilities Operations*. 5th ed., Lancaster Press, Lancaster, Pa, 1969.

URS/Forrest and Cotton, Inc., Consulting Engineers. "Report to the City of Dallas on Distribution System Analysis." January 1958.

---

# SECTION 9.2

---

# SEWAGE TREATMENT

---

H. H. BENJES, SR.  
W. E. FOSTER  
D. A. HOUSE

Sewage is defined as the spent water of a community. Although it is more than 99.9% pure water, it contains wastes of almost every form and description. Raw sewage, when fresh, is gray and looks something like dirty dishwater containing bits of floating paper, garbage, rags, sticks, and numerous other items. If allowed to go stale, it turns black and becomes very malodorous. About 25% of the waste matter of normal domestic sewage is in suspension; the remainder is in solution.

Sewage contains many complex organic and mineral compounds. The organic portion of sewage is biochemically degradable and, as such, is responsible for the offensive characteristics usually associated with sewage. Sewage contains large numbers of microorganisms, most of which are bacteria. Fungi, viruses, and protozoa are also found in sewage, but to a lesser extent. Although most of the microorganisms are harmless and can be used to advantage in treating the sewage, the viruses and some of the bacteria are pathogenic and can cause disease.

Sewage flow generally averages between 50 and 200 gallons per capita per day (gpcd) (190 and 760 lpcd). In the absence of better information, an average figure of 100 gpcd (380 lpcd) is generally used for design purposes. The rate of flow usually varies from minimum in the early morning to maximum in the later afternoon. Minimum flow ranges from 50 to 80% and maximum dry-weather flow from 140 to 180% of average flow. The extent of variation decreases as the size of the system increases. Wet-weather flows can be 600 gpcd (2270 lpcd) or more because of the extraneous water entering sewers from roof drains, areaway drains, footing drains, and so on.

## **SEWAGE SYSTEMS**

---

In most instances, sewage systems are divided into two parts: collection systems and treatment systems.



FIGURE 1 Factory-built conventional lift station (Smith & Loveless, Inc.)

**Collection** Collection systems consist of a network of sewers that collect and convey sewage from individual residences, commercial establishments, and industrial plants to one or more points of disposal. Pumping stations are often needed at various points in the system to pump from one drainage area to another or to the treatment plant. The judicious location of pumping stations enhances the economy of the overall design by eliminating the need for extremely deep sewers.

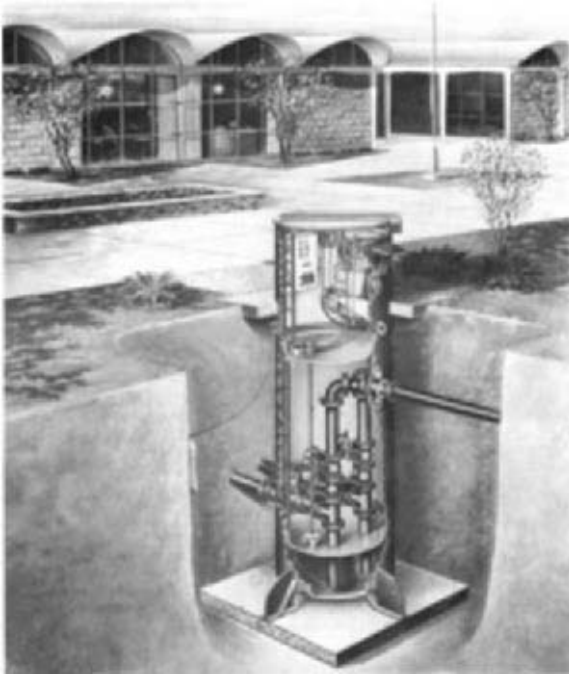
Small-system pumping stations (Figures 1 and 2) are frequently built underground and may be factory-built. For larger stations, superstructures should be in keeping with surrounding development. It has been said that people smell with their eyes and their ideas as well as their noses, and for this reason aboveground structures should be attractive, with landscaped grounds, to overcome the popular prejudices against sewage works. Stations can be and have been designed and constructed in residential areas where the neighbors apparently are not aware that the stations are not homes.

**Treatment** Treatment facilities can be many and varied, with the extent and nature of the treatment determined to a large degree by the proposed use of the receiving stream and its ability to assimilate pollutants. Most conventional treatment plants being built today can be classified as either primary, biological, or advanced waste treatment. Other alternatives, such as physical-chemical or chemical-biological treatment, are also used on occasion but on a lesser scale. The treatment needs of smaller communities are sometimes satisfied by package treatment plants or by waste stabilization lagoons.

Primary treatment involves removal of a substantial amount of the suspended solids but little or no colloidal or dissolved matter. Primary treatment facilities normally include screening, grit removal, and primary sedimentation. The sewage is often chlorinated during primary treatment in order to sterilize the wastes.

Biological treatment uses bacteria and other microorganisms to break down and stabilize the organic matter. Trickling filters and the many variations of the activated sludge





**FIGURE 2** Factory-built pneumatic ejector lift station (Smith & Loveless, Inc.)

process are the most popular biological treatment concepts presently in use. Biological treatment is generally followed by final sedimentation of the solids produced by the microorganisms.

Advanced waste treatment is a very complex subject, and it can range from a limited objective, such as phosphate removal, to whatever additional treatment is necessary for water reuse purposes. Advanced waste treatment usually follows conventional primary and biological treatment and can include phosphate removal, nitrate removal, multimedia filtration, carbon absorption, and ion exchange. Where zero discharge is required, it may be necessary to follow advanced waste treatment with spray irrigation of the plant effluent or other methods of disposal.

Combined primary and biological treatment using the activated sludge process is perhaps the most commonly used treatment concept currently in use. A schematic drawing of a typical activated sludge treatment plant is shown in Figure 3. In the example, liquid treatment is accomplished by coarse screening, grit removal, fine screening (or communication), and primary settling, followed by aeration, final settling, and chlorination. Sludge processing includes thickening, dewatering, incineration, and liquid disposal of ash. There are many variations to this layout, but the one shown includes most of the pumping applications normally encountered in treatment plant design. Pumping requirements will of course vary from plant to plant, depending on the process used, the site size and topography, and the relative location of the various structures and equipment.

### **PUMP APPLICATIONS**

---

Most of the pumping applications associated with the collection and treatment of sewage can be classified according to the general nature of the liquid to be handled. The primary

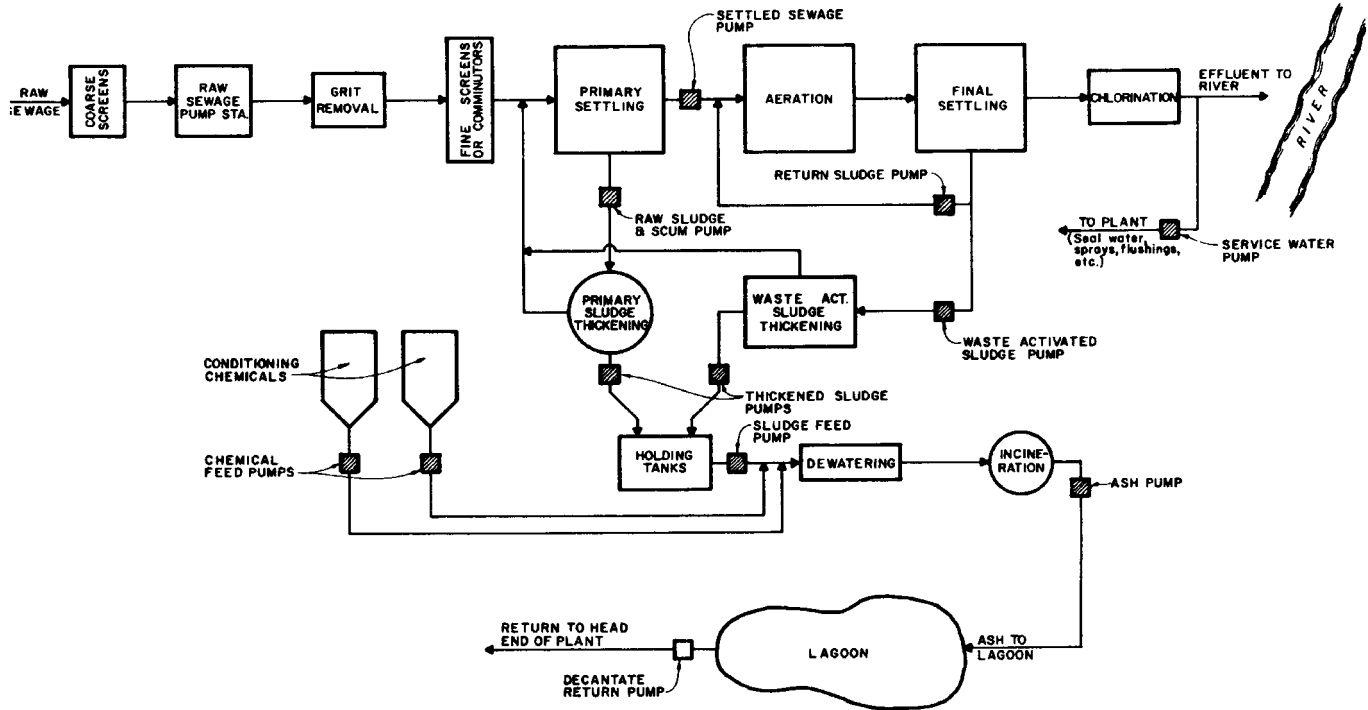


FIGURE 3 Typical activated sludge plant, with dewatering, incineration, and liquid disposal of ash

classifications are (1) raw sewage, (2) settled sewage, (3) service water, and (4) sludge. There are also, however, a number of specialized applications involving the handling of abrasive materials, such as grit and ash. The types of pumps recommended for sewage applications are indicated in Table 1. Although included in the table, chemical pumps are not discussed in this section. They are covered in Section 9.6.

**Raw Sewage** Raw sewage pumps are used to lift liquid wastes from one level of the collection system to another or to the treatment plant for processing. Regardless of where the pumps are located, the basic design considerations remain the same.

Even though the sewage is normally screened at larger installations before entering the suction wet well, it still contains a large quantity of problem material, such as grit, rags, stringy trash, and miscellaneous solids small enough to pass through the coarse screens. Screens are often omitted from smaller installations because large objects are not as much of a problem because of the smaller size of the incoming sewers.

Raw sewage pumping installations are usually sized so their firm capacity either is equal to a future maximum flow rate of the incoming sewers or can be expanded to accommodate this level. *Firm capacity* is defined as total station capacity with one or more of the largest units out of service.

Pneumatic ejectors (Figure 2) are sometimes used where the required capacity is less than that provided by the smallest conventional sewage pump. This type of unit, however, should not be used where more than 50 connections are expected.

Conventional sewage pumps are, by far, the most common pumps used for the handling of raw sewage. A conventional sewage pump is more specifically described as an end-suction, volute-type centrifugal with an overhung impeller of either the nonclog (Figure 4a) or the radial- or mixed-flow type (Figure 5), depending on capacity and head.

Nonclog pumps are all based on an original development by Wood at New Orleans. Actually, no pump has been developed that cannot clog, either in the pump or at its appurtenances. Experience shows that rope, long stringy rags, sticks, cans, rubber and plastic goods, and grease are most conducive to clogging.

Nonclog impellers are used almost exclusively today for pumps smaller than 10 in (25 cm). These pumps differ from clear-water pumps in that they are designed to pass the largest solids possible for the pump size. The conventional nonclog impeller contains two blades, although some manufacturers are now offering a single-blade (“bladeless”) impeller. The two-blade impeller has thick vanes with large fillets between the vanes and the shroud at the vane entrance. The bladeless impeller has no vane tips to catch trash. On the other hand, it is inherently out of balance because of its lack of symmetry.

The larger raw sewage pumps are equipped with either mixed-flow or radial-flow impellers, depending on head conditions. Both have two or more vanes, depending on pump size and the size of solids to be handled. The vane tips are sharper than for the non-clog impeller, resulting in a higher operating efficiency. The heavier vanes are not necessary because the vane openings can be larger than on the smaller pumps. Experience indicates that stringy trash will not clog an impeller with vane openings larger than 4 in (102 mm) in diameter.

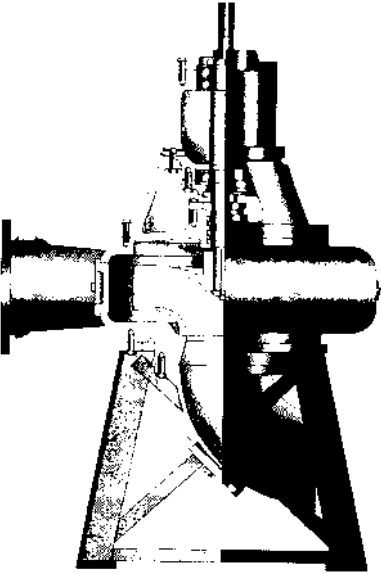
Conventional solids handling volute type sewage pumps may be of the dry pit type (Figure 4a), wet pit type (Figure 4b), or submersible type (Figure 4c). Dry pit pumps are by far the most popular and widely used type due to their accessibility for observing mechanical operation and ease of maintenance when necessary.

Wet pit solids handling pumps are gaining in popularity especially on return activated sludge services. They are similar in design to a vertical turbine or mixed-flow diffuser pump except the bowl contains a limited number (usually two) of well-rounded diffusers, the impeller is of the solids handling type, and there is no lower suction bell bearing. Therefore, they are not nearly as likely to clog on the debris normally found in raw sewage. Single-stage models available at the time of this publication are limited to operational total heads under 100 ft (30 m).

Submersible solids handling pumps are commonly used in small raw sewage lift stations. They are most widely used in sizes 12 in (305 mm) and smaller with total heads under 100 ft (30 m) and motor ratings under 150 HP (112 kW).

**TABLE 1** Types of pumps generally used in sewage applications

Application	Conventional sewage	Diffuser	Torque flow	Clear-water volute	Ash	Screw	Pneumatic ejector	Air lift	Positive displacement	Chemical
Raw Sewage	X	...	...	...	...	X	X	...	...	...
Grit	...	...	X	...	...	...	...	X	...	...
Primary sludge										
Less than 2% solids	X	...	X	...	...	...	...	...	...	...
More than 2% solids	...	...	...	...	...	...	...	...	X	...
Normal primary scum	...	...	...	...	...	...	...	...	X	...
Diluted scum	X	...	...	...	...	...	...	...	...	...
Biological sludge	X	X	...	...	...	X	...	X	...	...
Thickened biological sludge	...	...	...	...	...	...	...	...	X	...
Digested sludge, recirculation	X	...	X	...	...	...	...	...	...	...
Settled sewage	X	X	...	...	...	X	...	...	...	...
Plant effluent	X	X	...	...	...	X	...	...	...	...
Service or nonpotable water	X	X	...	X	...	...	...	...	...	...
Ash sluice	...	...	...	...	X	...	...	...	...	...
Decantate or supernatant liquor	X	X	...	...	...	...	...	...	...	...
Chemical solution	...	...	...	...	...	...	...	...	...	X



**FIGURE 4a** Non-clog dry pit sewage pump (Flowserve Corporation)



**FIGURE 4b** Solids handling wet pit pump (Flowserve Corporation)



**FIGURE 4c** Non-clog submersible sewage pump (Flowserve Corporation)

Although non-clog pumps 8 in (203 mm) and small are available with self-priming (Section 2.4), most conventional sewage pumps are located so the impeller is always below water level in the suction wet well. This eliminates the need for specialized priming systems.

Self-priming pumps have been used successfully to pump raw unscreened sewage, particularly in the southern part of the United States. The self-priming feature eliminates the



**FIGURE 5** Vertical sewage pumping units at the South System Pump Station, Deer Island in Boston, MA containing (8) 36 in (915 mm), 46,300 gpm (10,510 m<sup>3</sup>/h) pumps driven by 1250 hp (932 kW) variable speed motors (Flowsolve Corporation)

dry-pit cost and gives the centrifugal pump the gas-handling advantage of positive displacement pumps. Operating costs are higher, though, because the design efficiencies generally run about 10 to 15% lower than for the conventional nonclog units.

Archimedean screw pumps (Figure 6) are occasionally used for raw sewage pumping applications. These units are advantageous in that they do not require a conventional wet well, and they are self-compensating in that they automatically pump the liquid received regardless of quantity as long as it does not exceed the design capacity of the pump. This is done without the need for variable speed drive equipment. Also, as shown by Figure 6, the total operating head of a screw pump installation is less than for those pumps that require conventional suction and discharge piping. Screw pumps, however, have a practical limitation as to pumping head. Generally speaking, they are not used for lifts in excess of 25 ft (7.6 m).

**Settled Sewage** Settled sewage pumps are used to lift partially or completely treated waste from one part of the plant to another or to the receiving stream. In Figure 3, these pumps are the settled sewage pump, service water pump, and decantate return pump.

The liquid to be handled usually contains some solids, but grit and most of the rags and other stringy material have already been removed. Sufficient firm capacity should be provided to meet peak flow requirements. In no case should fewer than two units be provided.

Wet pit solids handling or diffuser pumps (Subsection. 2.2.1) are commonly used for the pumping of settled sewage. Depending on the total head conditions and degree of solids removal, a diffuser pump selection may be of either the propeller or mixed-flow design. However, solids-handling wet pit pumps are gaining in popularity due to their greater freedom from clogging. Although normally installed in wet-pit applications, these units are sometimes mounted on suction piping and installed in a dry pit. Either type of application is acceptable, although economics usually dictates a wet-pit installation. Head and capacity conditions will determine which type of unit is applicable.

Conventional sewage pumps may also be used to pump settled sewage. They may be of the dry pit, wet pit, or submersible type. It is not usually as economical to design a dry pit for this application, but it is acceptable as far as suitability of equipment is concerned.

Archimedean screw pumps can be used to pump settled sewage, provided the lift is not excessive. As previously noted, this type of pump has certain inherent advantages.

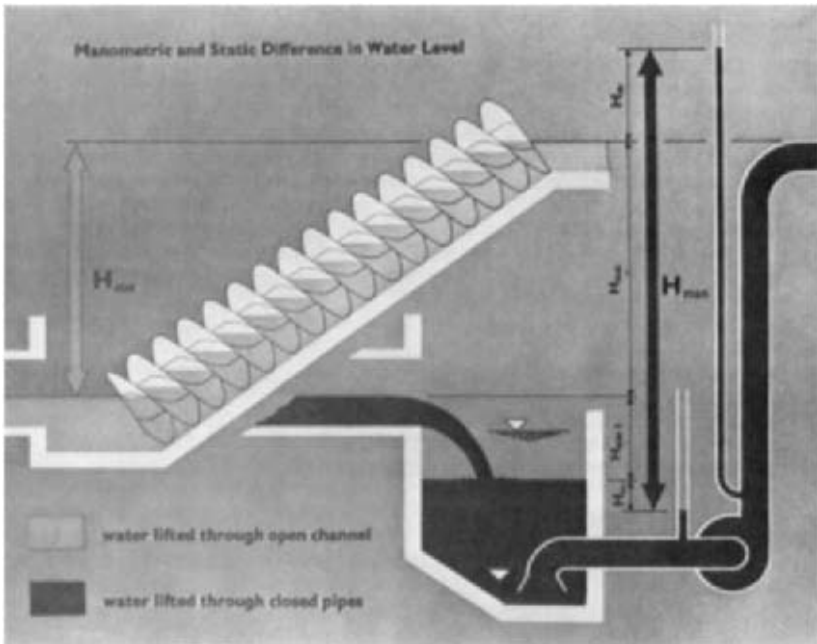


FIGURE 6 Archimedean screw pump (U.S. Filter/Zimpro)

**Service Water** Plant effluent water is frequently used for flushing, gland seal, foam control sprays, chlorine injector operation, lawn sprinkling, fire protection, and various other services in a waste-water treatment plant. Except for the fact that some solids must be contended with, this application is much the same as that found in building-water supply and small distribution systems.

Screening of solids is normally required; this can be accomplished either before or after the pumps, depending upon various circumstances. Pipeline-type strainers are recommended as they are not only economical but require a minimum of space, can be automatically backflushed, and are much easier to operate than alternative equipment.

Any type of conventional volute or diffuser clear-water pump can be used on service water applications, provided the effluent water is screened prior to entering the pump. Pumps capable of handling some solids should be used in those instances where pre-screening is not practical.

**Sludge and Scum** This classification is divided into two separate categories, based on the concentration of solids in the liquid to be handled. Specialized pumping equipment is required for more concentrated sludges, whereas pumping of dilute sludge and scum is somewhat comparable to the handling of settled sewage.

**DILUTE SLUDGE OR SCUM** For the purposes of this discussion, *dilute sludge* and *scum* is defined as having less than 2% solids. An exception is digested sludge recirculation, which generally exceeds the 2% limit. This is included along with the more dilute sludges because the same type of pumping equipment is used.

Normally, the handling of dilute sludge is limited to the transfer of biological sludge back to the treatment process or to some other point for further concentration or dewatering and disposal. When digesters are used as part of the treatment facilities, sludge is often recirculated through external heat exchangers in order to maintain temperatures

conductive to anaerobic bacterial action. This recirculation also helps keep the contents of the digester mixed. Occasionally, primary sludge and scum are handled in diluted form.

The firm capacity of dilute sludge pumping facilities should be equal to anticipated peak loading. Biological sludge return pumps should have a capacity range from 25 to 100% of average design raw sewage flow to the plant. Digested sludge recirculation pumps should be sized to turn over the contents of the digester frequently enough to maintain the desired temperature. Diluted primary and waste biological sludge pumps should have sufficient capacity to handle peak sludge loading at conservative solids concentrations.

Conventional sewage pumps are suitable for handling dilute sludge and scum. Either the non-clog or mixed-flow impeller may be used, depending upon capacity requirements.

Diffuser pumps are particularly suitable for handling biological sludge that does not contain any appreciable amount of trash or stringy material. They are not recommended, however, for handling diluted scum or for recirculating digested sludge. Depending on capacity requirements, diffuser pumps may be of either the mixed-flow or propeller design. Wet-pit applications are most common, although dry-pit installations are occasionally used.

Torque flow (or vortex) pumps (Figure 7) are often used to handle dilute sludges that contain some grit. These units are particularly suitable for this type of service because their design is such that close running tolerances are not required; this allows the use of specially hardened materials, such as high-nickel iron, which are not easily machined. The most common applications of torque flow pumps are for the pumping of nondegritted dilute primary sludge to gravity thickening and the recirculation of digested sludge.

Screw pumps can be used in certain instances for handling biological sludge. Use of screw pumps is generally limited to low to medium lifts and to those instances where the point of discharge is close to the sludge source.

Air-lift pumps are suitable for transferring biological sludge where the lift is small and the point of discharge nearby. A typical air-lift pump installation is shown in Figure 8. Total head should not exceed 4 to 5 ft (1.2 to 1.5 m). The ability of an air-lift pump to vary capacity is somewhat limited, ranging from about 60 to 100% of the rated amount. These pumps are inexpensive in first cost but have an operating efficiency of only about 30%. They are very easy to install, and maintenance is minimal because there are no moving parts. Air-lift pumps are commonly used to transfer sludge at package treatment plants.

**CONCENTRATED SLUDGE OR SCUM** Concentrated sludge or scum is defined as having more than 2% solids. The single exception is in the case of the recirculation of digested sludge. As previously discussed, this has been included in the dilute sludge classification.



**FIGURE 7** Torque flow pump (EnviroTech Pumpsystems, a Weir Group company)



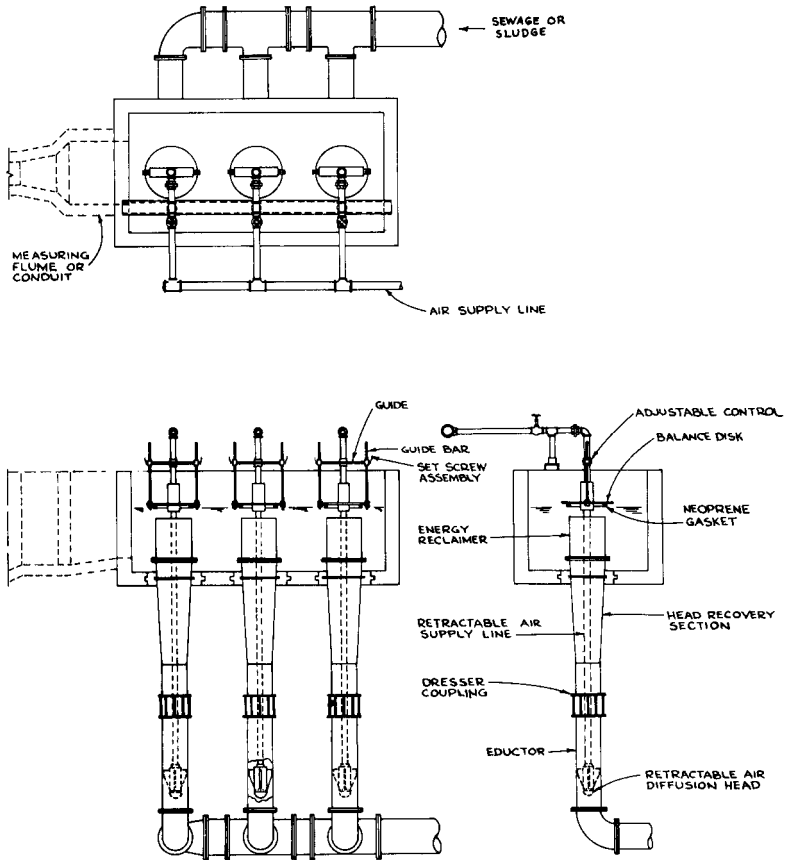


FIGURE 8 Typical air-lift pump installation (Walker Process Equipment Division, McNish Corp.)

Each pumping installation should have enough firm capacity to handle peak design sludge quantities while operating part-time. The proportion of operating time at peak loading should vary from about 25% for primary sludge pumps to close to 80% for pumps feeding dewatering equipment.

Only positive displacement pumps are recommended for handling concentrated sludge and scum, mainly because they can pump viscous liquids containing entrained gas without losing prime. Also, these materials are thixotropic, and conventional formulas for frictional losses are not always valid. An arbitrary allowance of at least 25 lb/in<sup>2</sup> (170 kPa) should be added to the pumping head calculated by conventional methods to allow for changes in viscosity and partial clogging of pipelines. Positive displacement pumps are able to maintain a relatively constant capacity regardless of variations in discharge head.

For most applications, positive displacement pumps may be of either the plunger (Figure 9) or the progressing cavity design (Figure 10). The performance of both depends upon close running clearances; consequently they have a high incidence of maintenance, especially where gritty substances are encountered. Even so, they represent the best pumping equipment currently available, and both designs have been used with success. Lobe-type gear pumps have been used for specialized applications. These are to be avoided, however, where there is any possibility that the material to be pumped will contain even a small amount of grit.

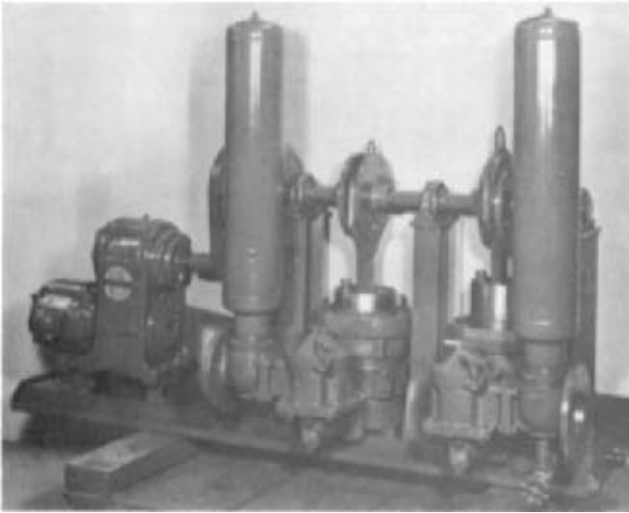


FIGURE 9 Plunger-type sludge pump (ITT Marlow Pumps)



FIGURE 10 Progressing cavity sludge pump (Mono Pumps Ltd.)

Plunger pumps should be of the heaviest design available and should be rated for capacity at about one half of full stroke. The shorter the stroke, the more stable the operation and the less maintenance required. Heads as high as 80 to 100 lb/in<sup>2</sup> (550 to 690 kPa) are available and should be specified in order to give as much flexibility as possible.

Specially designed progressing cavity pumps are available for handling sewage sludges. Wear increases along with pump speed, and so excessive speed should be avoided. Ideally, the maximum speed of a progressing cavity pump should not exceed 350 rpm. These units are readily available with head capabilities up to 50 lb/in<sup>2</sup> (345 kPa) and should be so specified.

Certain of the newer sludge conditioning and dewatering processes, such as heat treatment and pressure filtration, require pumps having a head capability in excess of 500 lb/in<sup>2</sup> (3450 kPa). This is extremely difficult service, and special care should be taken in selecting the type of equipment to be used. So far, this area of application has received very little consideration from pump manufacturers.

**Other Uses** Grit may be handled with reasonable success with either a torque or an air-lift pump. Considerable flushing water is required with a torque flow pump, and to a

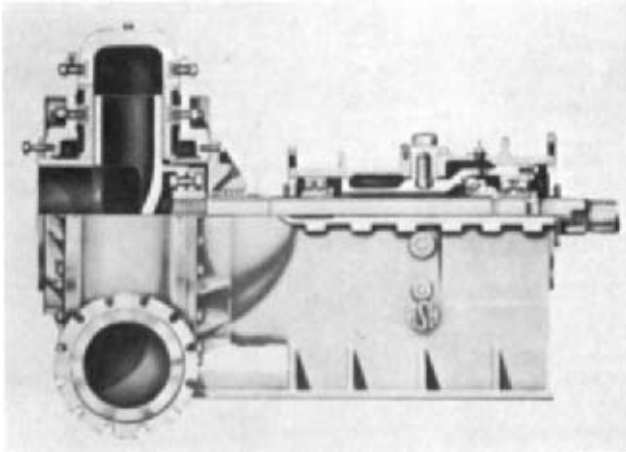


FIGURE 11 Ash pump (EnviroTech Pumpsystems, a Weir Group company)

lesser extent with an air-lift unit. A special ash pump (Figure 11) is required where it is necessary to dispose of incinerator residue in a liquid form. These units are especially designed for ash sluicing service and are made of special hardened metals. No other pump should be considered for this service.

## PUMP SELECTION

Various factors should be considered when selecting pumping equipment. These include the number of units to be installed, operating frequency, and station reliability requirements. After these factors have been fully evaluated, head-capacity curves should be prepared in order to match the pumps properly with system requirements. This is necessary because the capacity of most pumps varies with the total head at which the unit operates. When a pump is referred to as having a certain capacity, this capacity applies to only one point on the characteristic curve.

**Number of Pumps** The number of pumps to be provided at a particular installation depends largely on the required capacity and range of flow. In considering capacity, it is customary to provide a total pumping capability equal to the maximum expected inflow with at least one of the largest pumping units out of service. A minimum of two pumps should be installed in any installation except where pneumatic ejectors are used to serve fewer than 50 houses. Two pumps are customarily installed where the maximum inflow is less than 1.0 mgd (160 m<sup>3</sup>/h). At larger installations, the size and number of units should be such that the range of inflow can be met without starting and stopping pumps too frequently and without requiring excessive wet-well storage capacity. Variable-capacity pumps can be used to match pumping rate with inflow rate.

Where variable-capacity pumps are used, a minimum of two units should be installed. In those cases where more than one variable-capacity unit is required to handle peak flow, three units should be installed. In this manner, it is possible to maintain a reasonable rate of flow through each pump. Operation of a single variable-capacity pump in parallel with a constant-capacity pump requires the variable-speed unit to operate at almost no capacity whenever total inflow barely exceeds the rating of the constant-capacity unit. This is

extremely difficult service and should be avoided. As a general rule, pumping rates of less than 20% of the rated capacity for which a pump is designed will result in excessive internal recirculation and unstable operation. Recirculation can occur in some pumps at more than 50% of rated capacity. See Subsection 2.3.1.

**Operating Frequency** Pump size should be coordinated with wet-well design in order to avoid frequent on-off cycling of pumps. Excessive starting will cause undue wear on the starting equipment. Also, standard motors should not be started more than six times an hour. Where more frequent starting is required, special motors should be provided. Inflow into the wet well without pumping should not exceed about 30 minutes if septicity is to be prevented.

Cycle time is defined as the total time between starts of an individual pump. It can be determined by comparing the volume between the on and the off levels in the wet well with the pump capacity. Cycle time is computed as follows:

$$\text{In USCS units} \quad CT = \frac{V}{D - Q} + \frac{V}{Q}$$

$$\text{In SI units} \quad CT = 60 \left( \frac{V}{D - Q} + \frac{V}{Q} \right)$$

where  $CT$  = cycle time, min

$V$  = wet-well volume between on and off levels, gal ( $\text{m}^3$ )

$D$  = rated pump capacity, gpm ( $\text{m}^3/\text{h}$ )

$Q$  = wet-well inflow, gpm ( $\text{m}^3/\text{h}$ )

With a given wet-well volume and pumps having a uniform pumping rate, minimum cycle time will occur when the rate of inflow is equal to one-half the discharge rate of the individual pump under consideration. The formula for cycle time simplifies to

$$\text{in USCS units} \quad CT = \frac{2V}{Q}$$

$$\text{in SI units} \quad CT = \frac{120V}{Q}$$

An effective wet-well volume of at least 2.5 times the discharge rate of the pump under consideration is required in order not to exceed the six starts per hour recommended above for pumps having a uniform pumping rate.

**Reliability** With its increased awareness of and concern for environmental matters, the public has little tolerance for the bypassing of sewage equipment because of power outages, equipment failure, insufficient pumping capacity, or any other reason. Reliability is of extreme importance, and the design of pumping facilities should be premised on providing continuous service. Where electric motors are used, two incoming power lines from separate sources with automatic switching from the preferred source to the standby source are the minimum required for reliability. Standby engine-driven pumps, engine-driven right-angle gear drives, or standby engine-driven generators should be provided where dual electric service cannot be obtained or where the degree of reliability provided by two feeds is not considered adequate. Raw sewage pumping installations are particularly critical. Plant pumping installations usually can be out of service for as long as four hours without adversely affecting the treatment process, provided the liquid will flow by gravity through the plant.

**Speed** The maximum speed at which a pump should operate is determined by the net positive suction head available at the pump, the quantity of liquid being pumped, and the total head. When specifying pumps, especially those that are to operate with a suction lift,

the speed at which the pumps will operate should be checked against limiting suction requirements as set forth by the Hydraulic Institute.

In general, it is not good practice to operate sewage pumping units at speeds in excess of 1750 rpm. This speed is applicable only to smaller units. Larger pumps should operate at lower speeds.

**Preparation of Head-Capacity Curves** Pump selection generally involves preparation of a system head-capacity curve showing all conditions of head and capacity under which the pumps will be required to operate. Frictional losses can be expected to increase with time, materially affecting the capacity of the pumping units and their operation. For this reason, system curves should reflect the extreme maximum and minimum frictional losses to be expected during the lifetime of the pumping units as well as high and low wet-well levels.

Where two or more pumps discharge into a common header, it is usually advantageous to omit the head losses in individual suction and discharge lines from the system head-capacity curves. This is advisable because the pumping capacity of each unit will vary depending upon which units are in operation. In order to obtain a true picture of the output from a multiple-pump installation, it is better to deduct the individual suction and discharge losses from the pump characteristic curve. This provides a modified curve that represents pump performance at the point of connection to the discharge header. Multiple-pump performance can be determined by adding the capacity for points of equal head from the modified curve. Figure 12 shows a typical set of system curves, together with representative individual pump characteristic curves, modified pump curves, and combined modified curves for multiple-pump operation. Intersection of the modified individual and combined pump curves with the system curves shows total discharge capacity for each of the several possible pumping combinations. A typical set of system curves consists of two curves with a Williams-Hazen coefficient of  $C = 100$  (one for maximum and one for minimum static head) and two curves with a Williams-Hazen coefficient of  $C = 140$  (for maximum and minimum static head). These coefficients represent the extremes normally found in sewage applications.

Pumps should be selected so the total required capacity of the installation can be delivered with maximum water level in the wet well and maximum friction in the discharge line. Pump efficiency should be maximum at average operating conditions. In the case of Figure 12, assuming that the total capacity of the installation is to be obtained by operating pumps 1, 2, and 3 in parallel, the total head required at the discharge header would be approximately 51 ft (15.5 m). Projecting this point horizontally to the individual modified pump curves and thence vertically to the pump characteristic curves, the required head for pumps 1 and 2 should be 54 ft (16.5 m) and for pump 3 approximately 57 ft (17.4 m). The difference between the head obtained from the pump characteristic curve and the modified curve is the head loss in the suction and discharge piping for the individual pumping units.

Figure 12 also shows the minimum head at which each pump has to operate, approximately 39 ft (11.9 m) for pumps 1 and 2, and about 42 ft (12.8 m) for pump 3. These minimum heads are important and should be made known to the pump manufacturer because they will usually determine the maximum brake power required to drive the pump and the maximum speed at which the pump may operate without cavitation.

## **PUMP DRIVERS**

---

In the majority of cases, pumps are driven by electric motors. Sometimes, however, they are driven by gasoline, gas, or diesel units where firm power is not available or where pumping is required only at infrequent intervals. Variable-speed drivers are used extensively in sewage applications. These units generally consist of variable-speed motors or constant-speed motors with adjustable slip couplings of either the eddy-current or the fluid coupling type. Selection of the type of variable-speed driver to be used is usually based on space considerations, initial cost, operating cost over the expected life of the equipment, and customer preference. Emphasis is increasingly being placed on operating cost over the expected life due to government and environment requirements. See Section 6.2 for these and other types of speed-varying devices.

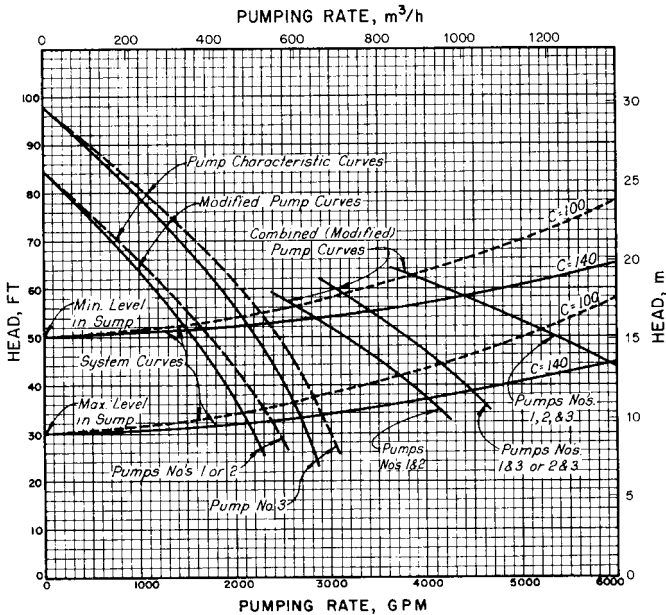


FIGURE 12 Typical head-capacity curves

Variable-speed drivers are particularly appropriate for raw sewage installations that discharge to a treatment plant. Use of this equipment allows the treatment facilities to operate continuously instead of intermittently surging the plant at incremental pumping rates. Variable-speed drivers are used to pump settled sewage and biological sludge where intermittent surging would adversely affect the process. Also, sludge pumps used to feed dewatering equipment are often equipped with variable-speed drives because it is necessary to vary the rate of discharge with the dewatering characteristics of the sludge.

For dry pit applications, the choice between horizontal- and vertical-drive motors depends considerably upon the station arrangement and available space. Horizontal motors are usually preferred, provided there is space and no potential flooding problem. Horizontal pumps are more easily maintained, and they are generally less expensive in first cost. Vertical drivers are generally used, however, for the pumping of raw sewage because of their smaller space requirements. Also, vertical units are advantageous in that the motor is located higher and is less susceptible to flooding.

In vertical dry-pit installations, intermediate shafting is normally preferred. This allows the drivers to be located above a potential flood level in the station. However, the use of intermediate shafting can become quite expensive in terms of initial installation costs and maintenance costs. Additionally, they may be prone to vibration problems if proper precautions are not taken in the design of the station. Vertical drive motor can also be mounted directly above a pump without the use of intermediate shafting. In doing so, it is connected to the pump by means of a suitable coupling. A separate support or bracing of the motor may also be required to provide for adequate installed stiffness.

## PUMP CONTROLS

Some means of controlling pump operation is required at most pumping installations. This is usually done from either wet-well level or flow.

**Level Control** With level control, each pump is turned on and off at specific water levels in the suction wet well; in the case of variable-capacity pumps, the level control attempts to maintain a preset level, once started. Pumps turn on with a rising level and off as the level lowers. Level control is generally used in raw sewage pumping applications. In this manner, it is possible to match discharge with incoming flow.

**Flow Control** Flow control is used sometimes where there is no limitation on the availability of flow to the pump suction and where it is desirable to maintain a predetermined rate of discharge. Where flow control is used, a flowmeter is used as the primary instrument to measure flow and to serve as a basis for varying pump speed, which in turn controls capacity. The speed can be changed either manually or automatically through closed-loop instrumentation.

**Additional Level Control** Low-water pump cutoff and high-level alarm are provided on most pumping installations. The low-level cutoff is required to prevent the pumps from running dry, and the high-level alarm notifies the operator in the event the pump should fail to operate. When the pump stops because of low-water cutoff, there is usually some means of indicating this to the operator.

## MISCELLANEOUS DESIGN CONSIDERATIONS

---

In addition to the matters discussed previously, there are certain other items that should be given consideration in the design of pumping installations.

**Piping and Valves** Suction and discharge piping should normally be sized so the maximum velocities do not exceed 5 and 8 ft/s (1.5 and 2.4 m/s), respectively. Higher velocities, however, may be justified by economic analysis for particular installations. Lines less than 4 in (102 mm) in diameter should not be used for raw sewage. Preferably, sludge lines should be at least 6 in (152 mm) in diameter; 4-in (102-mm) lines are sometimes used for dilute biological sludge.

Valves should be installed as required on the suction and discharge sides of each pump to allow removal and maintenance of individual pumping units without disturbing the function of the remainder of the installation. It is customary to use either ball or plug valves on raw sewage and concentrated sludge applications. Either plug or butterfly valves can be used for settled sewage or for dilute sludge.

Piping should be designed with sufficient flexibility to avoid stress on the pump flanges. Flange-coupling adapters are sometimes used for this purpose on both the suction and discharge sides of the pump.

**Surge Control** Careful attention should be given to surge control wherever a pump discharges into a force main of appreciable length. Generally this is a problem only in the design of raw sewage pumping stations located within the collection system. Changes in fluid motion caused by starting or stopping of pumps or by power failure can create surge conditions.

Surges caused by normal starting and stopping of pumps driven by electric motors may be controlled (1) by selecting individual pump capacities such that the change in velocity in the system when a single pump starts or stops will not result in excessive surges, (2) by using variable-speed drives to bring pumps gradually on or off line, or (3) by using power-operated valves that are controlled so the pumps are started and stopped against a closed valve.

Surges caused by power failure can be controlled by devices designed to open on an increase in pressure, by devices that will exhaust sewage from the system upon sudden pressure drop in anticipation of surge, or by a surge tank.

**Pump Seals** Most sewage and sludge pumps can be obtained with either mechanical seals or packed stuffing boxes. Conventional mechanical seals have the disadvantage of requiring a pump to be disassembled so the seal can be repaired. Present mechanical seal



technology offers a solution to this in the form of a split mechanical seal. Such a seal can be removed and repaired or replaced without the necessity of disassembling the pumping unit.

Often it is easier to replace the seal rather than repair it, and it is desirable to keep a spare on hand for this purpose. Packed stuffing boxes provided with water-sealed lubrication are still the most common choice for non-submersible sludge and sewage pumps. Grease seals are sometimes used for some of the smaller sewage pumps that do not run continuously.

Water serves multiple purposes as a sealing medium: it seals, lubricates, and flushes. Flushing is particularly important where abrasive material is involved in that it helps prevent this material from entering the seal. Grit and ash are very abrasive, and either will cut the shaft sleeves in a relatively short time. Where pumps are controlled automatically, a solenoid valve interlock with the pump starting circuit should be provided in the seal water connection to each pump. A manual shutoff valve and strainer should be provided on each side of each solenoid valve, and a bypass line should be provided around it.

Mechanical seals are normally lubricated with a clean external water source supplied at a pressure and flow rate as recommended by the seal manufacturer. Seals can be lubricated by the product being pumped provided it is filtered and can provide a reliable pressure and flow rate to the seal cavity. In such cases, a connection is normally provided between the pump discharge and the seal with a 0.10 to 0.20 in (2.5 to 5 mm) in-line filter to prevent foreign material from entering the seal cavity.

Occasionally, a pump station is so remote that sealing water is not readily or economically available. Mechanical seals can be provided constructed of special materials to withstand such adverse conditions. Also, several types of "formed-in-place" packing are available that do not require a smooth surface on which to seal as the packing develops its own sealing surface. However, these packing materials are not normally recommended for temperatures over 130°F (54°C) or pressures over 60 lb/in<sup>2</sup> (4 bar).

**Pump Bearings** Pump bearings must be adequate for the service and should be designed on the basis of not less than a minimum life of five years in accordance with the Anti-Friction Bearings Manufacturers Association life and thrust values. The larger sewage pumps are usually equipped with both case and impeller rings of bronze or chrome steel.

**Cleanout Ports** Pumps should be provided, where possible, with cleanout ports on both the suction and discharge sides of the impeller. These are desirable for inspection and maintenance purposes.

**Wet-Well Design** Raw sewage wet wells should not be so large that sewage is retained long enough to go septic. It is usually desirable to limit storage to a maximum of 30 minutes. Shorter retention time is desirable. With the variable-speed controls now available, many stations can be designed so that the pumping rate matches the inflow rate and the inherent difficulties of frequent pump cycling or long retention times in wet wells can be avoided.

## FURTHER READING

---

American Society of Civil Engineers. *Design and Construction of Sanitary and Storm Sewers*. Manual and Report on Engineering Practice No. 37, WPCF Manual of Practice No. 9, New York, 1969, pp. 287–331.

Benjes, H. H. "Design of Sewage Pumping Stations." *Public Works*, August 1960.

Benjes, H. H. "Sewage Pumping." *J. Sanit. Eng. Div., Proc. ASCE*, June 1958.

Great Lakes-Upper Mississippi River Board of State Sanitary Engineers. *Recommended Standards for Sewage Works*. Health Education Service, Albany, NY, 1978.

Parmakian, J. *Water Hammer Analysis*. Prentice-Hall, Englewood Cliffs, NJ, 1955.



Rich, G. R. *Hydraulic Transients*. 2nd rev. ed., McGraw-Hill, New York, 1963.

Sanks, R. L. *Pumping Station Design*, Butterworths, Stoneham, MA, 1989.

Water Pollution Control Federation: *Design of Wastewater and Stormwater Pumping Stations*, WPCF Manual of Practice No. FD-4, Washington, DC, 1980.

Water Pollution Control Federation. *Safety and Health in Wastewater Systems*, WPCF Manual of Practice No. 1, Washington, DC, 1983.

Water Pollution Control Federation. *Wastewater Treatment Design*, WPCF Manual of Practice No. 8, Washington, DC, 1977.

---

# SECTION 9.3

---

# DRAINAGE AND IRRIGATION

---

JOHN S. ROBERTSON

---

## ***DRAINAGE PUMPS***

---

Drainage pumps are used to control the level of water trapped in a protected area. Entrapment occurs when high lake levels, stream stages, and tides preclude the normal discharge of streams, storm runoff, and seepage from the protected area. These high-water conditions are created by floods and hurricanes or impoundment.

Floods and hurricanes occur infrequently and are relatively short-lived. However, as normal drainage is not possible at such times, all interior drainage that cannot be ponded must be pumped over the protective works if the protective works is a levee or through it if it is a concrete flood wall. Pumps for this purpose are strategically located at the edge of pending areas and streams, in sewer systems, or in the protective works. These pumps are operated continuously or are cycled on and off as necessary to maintain the water level in the protected area below the elevation at which damage would be experienced. As their use is required only during emergency situations and usually under adverse weather conditions, reliability of operation is essential.

Where valuable low-lying areas must be protected against inundation due to backwater, gravity drainage from the area is generally not possible. In such situations, all seepage and storm-water runoff entering the protected area must be pumped. The pumping of seepage is often a continuous operation, whereas the pumping of storm-water runoff is intermittent. Both can occur simultaneously because inflow due to seepage does not stop during a rainstorm. It therefore is necessary to provide pumps that can handle seepage and storm water simultaneously.

---

## ***IRRIGATION PUMPS***

---

Irrigation pumps play an important part in making vast areas of arid and semiarid land agriculturally productive. These pumps take water from surface sources, from subsurface

sources, and in ever-increasing amounts from sewage treatment facilities and pump it to the point of application.

Water from surface sources, such as streams, lakes, and ponds, is pumped directly into the distribution system or into a conveyance system. If pumped into a conveyance system, it flows either by gravity or under pressure to the distribution point or to a booster pumping station. Most of the pumps used in these installations are mounted permanently and are arranged to operate as necessary without constant attendance during the growing season.

Water from subsurface sources is usually pumped directly into the distribution system. In such installations, a well is drilled in the vicinity of the area to be irrigated and is fitted with the proper size pump. In many instances, more than one well is needed to provide the required capacity.

Effluent waters from different types of sewage treatment facilities are sometimes used for irrigation on a year-round basis in land disposal systems. In these systems, the treated effluent is temporarily stored in holding tanks or ponds and is applied to the disposal area at predetermined rates via sprinkler systems. As the disposal area may be a considerable distance from the storage area and as pressure is needed for operation of the sprinkler system, pumping is required.

## **PUMP TYPES**

---

Centrifugal pumps are used almost exclusively in drainage and irrigation installations. Because of the large selection of propeller, volute, turbine, and portable pumps manufactured today, there is little difficulty in finding a pump that will meet the conditions encountered in these fields. Pumps in the sizes needed to meet the requirements of the majority of installations are available as standard items. Specialized pumps and extremely large pumps are designed and built to meet the needs of individual projects.

**Propeller Pumps** These units are used for low-head pumping. As most of the pumping in drainage and irrigation is low-head, the propeller pump is the most widely used type. In general, vertical single-stage axial- and mixed-flow pumps are used; however, there are instances where two-stage axial-flow pumps should be considered for economic reasons.

Horizontal axial-flow pumps are used for pumping large volumes against low heads and usually employ siphonic action when not of the submersible type. When higher heads are involved, these pumps can be arranged to operate with siphonic action until the back pressure places the hydraulic gradient above the pump.

Variable-pitch propeller pumps rotating at constant speed can be operated efficiently over a wide range of head-capacity conditions by varying the pitch of the propeller blades. These pumps are used when the head-capacity conditions cannot be met with the more economical fixed-blade pumps and where the pumps will be operated often enough and long enough to warrant the expense. The blade-control system needed for such pumps is more sophisticated than in any of the systems usually provided on drainage and irrigation projects. As a consequence, operation and maintenance must be performed by organizations employing competent and experienced personnel.

**Volute Pumps** Volute pumps are used when pumping from surface sources and in general when the total head exceeds approximately 45 ft (14 m). Such pumps are available in many types, such as vertical and horizontal shaft, end suction, bottom suction, and double suction with semi-open or closed impellers, and so on. These pumps are mounted in dry pits when located below grade and on slabs or floors when located above grade. The particular type used depends on the capacity and kind of service to be performed.

**Deep-Well Turbine Pumps** Deep-well turbine pumps (vertical-shaft, single-suction pumps having one or more stages) are used in irrigation primarily to pump water from a subsurface source into a distribution system. The head against which the pump will operate determines the number of stages that must be provided. For large capacities, more than one pump will be needed.

**Submersible Turbine Pumps** In these deep-well units, the motor is close-coupled to the pump and submerged in the well. This type of pump is used for high-head applications where long intermediate shafts are undesirable.

**Portable Pumps** In drainage work, portable pumps are used as emergency equipment to control ponding elevations where mobile equipment, such as tractors and trucks, having power takeoffs are available to drive them. In irrigation work, they are usually used to irrigate from a surface source. Such pumps are small-capacity, low-head, economical pumps that must be submerged in order to be used.

## **PUMP SELECTION**

---

A pump selection study should always be made, and its importance cannot be emphasized enough. Such studies permit selection of the type of pump and discharge system best suited to the project and provide the information needed to proceed with the design of the installation.

In many cases, the type of pump required will be obvious. If more than one kind of pump would be satisfactory, the specifications should permit the pump manufacturer to make the choice. This is particularly advantageous when competitive bidding is involved. The practice of the Corps of Engineers in this regard is to write a performance specification and allow the pump manufacturer to determine the type, size, and speed of the pump.

Before initiating such a study, all previous studies made to determine the total pumping requirement or station capacity, pertinent water-surface elevations, terrain, utility locations, proposed station or well locations, points of discharge, and the proposed method of operation should be reviewed. Also to be considered is the experience of the personnel that will be responsible for the operation and maintenance of the installation.

**Number of Pumps** First costs are generally of more concern than operating costs in drainage and irrigation work because the operating period for the majority of installations is relatively short and occurs only once a year. Costs can be minimized by using as few pumps as possible. However, one-pump installations are seldom used except in the case of wells. For reliability, a minimum of two pumps should be installed in drainage pumping stations, where the loss of even one pump during an emergency situation could result in considerable damage. Three or more pumps are preferred. Standby units are provided only in those installations where continuous operation precludes taking a pump out of service for maintenance.

The number of pumps ultimately used should be consistent with the demands of the project. For instance, when the installation is located in an agricultural area or is a part of an urban sewer system, a standby pump should be provided because these installations must always be capable of discharging project requirements during periods of blocked drainage. In this way, considerable damage may be avoided. When the installation is used to pump storm water from pondage or irrigation water from a lake, the loss of a pump is not critical and so a standby pump is not needed.

If during pump selection it is found that the rated power of the prime mover exceeds the maximum power requirements of the pump by a considerable amount, the contemplated number of pumps should be increased or decreased, provided the change results in a better power match without increasing the overall cost of the installation. By increasing the number of pumps and thereby reducing the required power, there is a possibility that the size of the prime mover can be reduced and that the pump power will approach the rated power of the prime mover. On the other hand, decreasing the number of pumps will increase the power requirements. This increase may be sufficient to either utilize most of the excess capacity in the prime mover or require the use of a larger one.

For installations requiring the use of large pumps, foundation conditions become important. To prevent the installation from being relocated to a less desirable site or the necessity of providing a more expensive pile foundation because the bearing pressures at

the selected site exceed the allowable limit, the number of pumps should be increased, provided the loading can be reduced to an acceptable amount and the resulting installation continues to be the most economical.

Inadequate depth on the suction side of the pumps may necessitate the use of more pumps. Should the water not be deep enough to provide the submergence needed by the contemplated pump, more pumps of a smaller size may have to be used or the sump and approach channel may have to be excavated to the needed depth. The latter alternative could cause operational and maintenance problems and might be the more expensive solution.

**Capacity** The capacity of a pump is a function of the total pumping requirement, the number of pumps, and, in the case of wells, the capacity of the well. Whenever possible, all pumps in a multiple-pump installation should be of the same capacity. This is advantageous from a cost standpoint as well as from a maintenance standpoint. In drainage installations, three pumps are generally provided in order to have the capability of pumping not less than two-thirds of the project requirement with one pump inoperative. Each pump would then have a capacity equal to one-third of the total capacity. When more than three are used, the capacity should be the total required capacity divided by the number of pumps being used. If two pumps are used, each pump should be sized to pump not less than two-thirds of the total capacity.

In irrigation installations utilizing multiple pumps, the capacity of each pump should be the same. In single-pump installations, the pump should be sized to meet project requirements. When wells are involved, the capacity of the pump will be determined by the capacity of the well. Often several wells are needed to give the capacity to satisfy the established requirements.

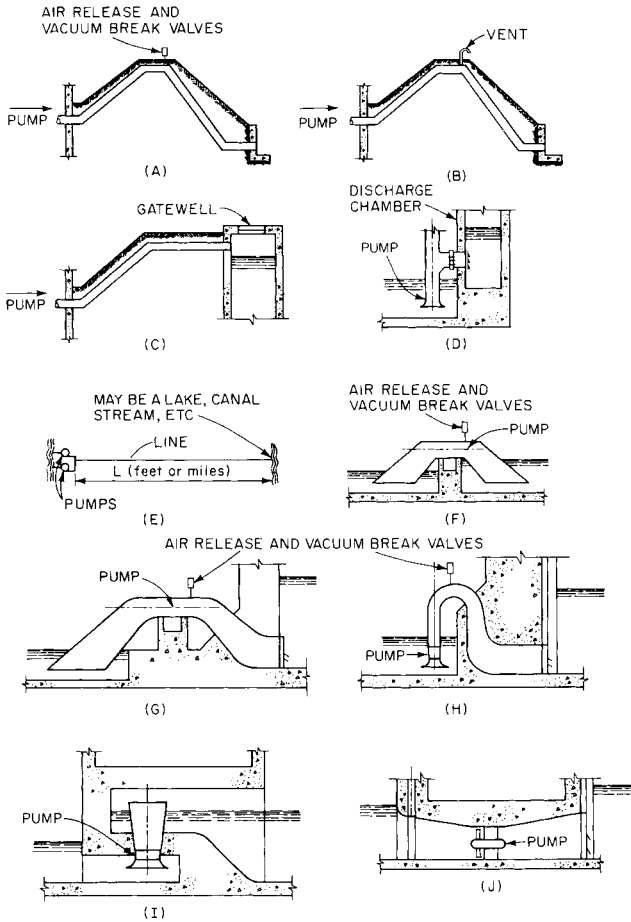
When a standby pump is to be provided, its capacity should be equal to that of the largest pump being furnished.

**Head** Total head is the algebraic difference between the total discharge head and the total suction head. In drainage and irrigation work total suction head can usually be determined, but this is not always the case for the total discharge head. The losses in the discharge systems often must be determined by hydraulic model test rather than by calculation and therefore must be estimated for preliminary selection purposes. The head specified will have to be some head other than total head; generally pool-to-pool head is used.

*Total discharge head* is defined in the Hydraulic Institute Standards, and its value is to a great extent determined by the type of discharge system used. A number of the many possible discharge systems used are shown in Figure 1. The losses in systems *A*, *B*, *C*, *D*, and *E* can be calculated. Thus the performance for pumps discharging into these systems can be put on a total head basis.

*System A* is an "over the levee" siphonic discharge line, the use of which can seldom be justified. However, continuous operation over long periods could effect a savings that would be sufficient to justify the additional cost of the installation and the taking on of the operational hazards usually encountered with such lines. The total discharge head for this system is equal to the height of the discharge pool, stream, or lake above the impeller plus the exit loss and the discharge line losses from the pump discharge nozzle to the line terminus. The absolute pressure at the high point of the line should be not less than 9 ft (2.7 m). Lower values have been used successfully, but this should be the exception rather than the rule. For additional information on the determination of heads in a siphonic system, refer to "Siphon Head" in Section 8.1.

Flap valves should be installed on the discharge end of all lines subjected to a cycling operation. The closing of these valves following pump shutdown prevents reverse flow into the protected area and permits development of the pressures needed to keep the lines full (primed) during those short periods when pumps are idle. These pressures will be less than atmospheric pressure, with the minimum pressure (absolute) being at the high point. Should there be significant leakage at the joints or in the valves, the pressures will rise and the water level at the high point will drop. If the water level drops below the invert of the line at the high point, the two legs of the line will be separated by an air space and priming will be necessary when the pump is started.



**FIGURE 1A through J** Discharge systems (adapted from Department of the Army, "Mechanical and Electrical Design of Pumping Stations," EM 1110-2-3105, Washington, DC, 1962)

Air-release valves should be installed at the high point of all siphonic discharge lines to provide an escape for the air being compressed as the water rises in the line during priming, and vacuum-break valves should be used to prevent reverse flow into the protected area. For lines equipped with flap valves, the vacuum-break valve should be manually operated and used when the flap gate fails to seat properly or to provide a rapid means of draining the line when pumping is no longer required. Units for almost any size line can be obtained from manufacturers who specialize in such equipment or they can be assembled, using swing check and angle valves.

*System B* in Figure 1 is an "over the levee" nonsiphonic discharge line. To preclude siphonic action, this line should be vented at the high point with a vent having a diameter that is approximately one-fourth that of the line. The invert of this line at the high point should be placed at the same elevation as the top of the protective works so the pumped flow can discharge from the down leg of the line under gravity without backwater effects for all discharge pool elevations up to maximum. Thus the total discharge head

will have a constant value because it will not be affected by changes in the level of the discharge pool. To ensure adequate prime mover capacity when using this system, it is the practice in all cases to use the top of the line at the high point in lieu of the hydraulic gradient when determining the total discharge head. Therefore, total discharge head is the height of the top of the line at the high point above the impeller plus the velocity head in the line at the high point based on a full pipe and the losses in the line from the pump discharge nozzle to the beginning of the down leg of the line.

*System C* is used when there is a conduit carrying the normal gravity discharge under the levee adjacent to the station that must be valved off against reverse flow into the protected area during periods of high water. The closure gate is located in a gate well constructed on the stream or lake side of the levee to prevent subjecting the gravity conduit to high-water conditions. The pump discharge lines go over the levee and terminate in the gate well above the maximum water level. This shortens the lines and reduces the cost. The total discharge head for this system is equal to the height of the top of the line at the terminal end above the impeller plus the exit loss and the losses in the line between the pump discharge nozzle and the terminal point. The total discharge head for this system, as in system *B*, is independent of the discharge pool and therefore constant. Neither flap valves nor vents are required on these lines.

*System D* is used when the pumping station is constructed as an integral part of the levee or flood wall. The invert of the pump discharge line is placed at an elevation that is above the stream or lake level that will prevail approximately 70% of the time or as is dictated by the physical dimensions of the pump. Owing to the extreme turbulence in the discharge chamber, gates with multiple shutters, which are less likely to be damaged, should be used instead of flap gates on discharge lines that are larger than 36 in (914 mm) in diameter. When the water level in the discharge chamber is below the top of the discharge line, the total discharge head is determined in the same manner as for system *C*. For higher discharge water levels, the total discharge head is equal to the height of the water level in the discharge chamber above the impeller plus the exit loss and the losses between the pump discharge nozzle and the chamber side of the flap valve.

*System E* is perhaps the most common discharge system in use today. It is used to connect one pump or several manifolded pumps with a lake, canal, stream, ditch, reservoir, or sprinkler system. For short lines and low static heads, valve and fitting losses, frictional losses, and exit losses are very important, whereas in long lines or very high static head installations only frictional losses are given consideration. In manifolded installations using propeller pumps, a check valve and gate valve are installed immediately downstream of the pump. The gate valve should always be opened before the pump is started because the motors provided are not usually sized to operate against shutoff head. Positive shutoff valves are placed immediately downstream of volute or turbine pumps because these pumps are usually started and stopped against a closed valve. They also prevent reverse flow into the sump when one of the pumps is inoperative.

*Pool-to-pool head* is the difference in elevation between the sump and discharged-water surfaces and is used instead of total head in drainage work because the losses in the discharge system are not easily determined. Installations of this type are exemplified by systems *F*, *G*, *H*, *I*, and *J* in Figure 1. For such installations, it is best to specify the pumps on a pool-to-pool basis, to have the pump manufacturer design the pump and the discharge system, and to verify the predicted performance by model test. It should be noted that in such installations the discharge systems are usually constructed within the confines of the pumping station structure.

*System F* is operated as a siphon with the pump supplying energy equivalent to the pool-to-pool head plus the system losses. The invert of the pump discharge pipe at the highest point is located above the maximum river stage, and vacuum pumps are generally used to aid in priming the pump. This system is used for pool-to-pool heads of up to approximately 6 ft (1.8 m) and where the physical dimensions of a vertical pump would make it necessary to operate against higher heads. In estimating the losses, entrance losses, which are small [approximately 0.14 ft (4 cm)], should be neglected. The centerline of the suction piping should be assumed to make an angle of 45° with the horizontal, and the diameter of the discharge piping as measured at the discharge flange of the discharge elbow should be such that the velocity at maximum discharge is approximately 12 ft/s (0.037 m/s) or less.

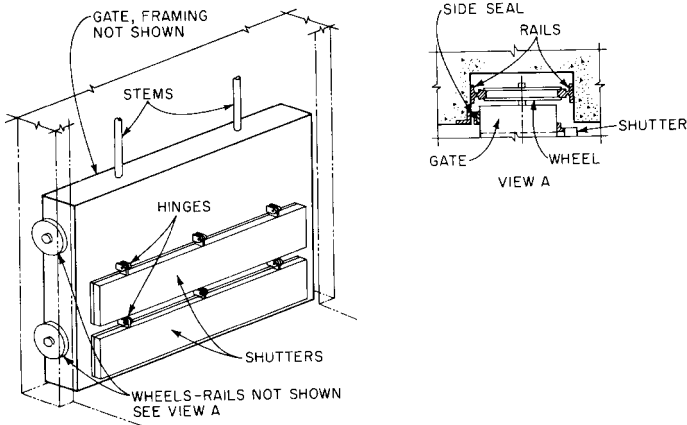


FIGURE 2 Multiple-shutter gates

*System G* is used for pool-to-pool heads of up to approximately 15 ft (4.6 m). The water passages change in cross-section from round at the pump bowl to rectangular at each end. The width at the suction end is the same as or less than that of the suction bay, and the height is such that the entrance to the suction passage is always submerged when the pump is in operation. The discharge velocity should be kept to approximately 6 ft/s (1.8 m/s). Multiple-shutter gates (Figure 2) arranged to be raised when the pump is in operation are provided to prevent prime mover overload when the pump is started and to prevent reverse flow when the pump is stopped or inoperative. These pumps are usually large and slow and require substantial prime movers. Vacuum priming equipment is used so additional power will not be required for priming.

*System H* is essentially the same as system *G*, except that the former is used for pool-to-pool heads up to approximately 26 ft (7.9 m). Also, a splitter may be required in the discharge water passage for structural purposes as well as for keeping the multiple-shutter gates to a reasonable size. The pumps used with this system are vertical and in general smaller than those used with system *C*.

*System I* can be constructed with the lip of the pump column either above or below the design flood elevation or the maximum surge, if it is being provided for hurricane protection. If the lip of the pump column is above and the chances of reverse flow through the pumps are extremely remote, gating of either the pump column or the discharge water passage is unnecessary. If the lip of the pump column is below, a decision of whether to gate both the pump column opening and the discharge water passage or just the water passage must be made. In general, if the pumps will be in operation continuously during high-water conditions and if reverse flow through an inoperative pump will not have substantial detrimental effects, only the multiple-shutter gate at the end of the discharge water passage need be provided. Reverse flow could occur should the flap for some reason fail to close. Like system *C*, splitter walls may be required if pumps are large. Also, the clearance between the lip of the pump column and the ceiling of the discharge water passage is critical and should be determined by model test.

The shape of the pump column lip will also affect pump efficiency and should be determined by test.

*System J* could have many configurations but, regardless of arrangement, would have to be gated on the suction side with a positive shutoff gate, such as a pressure-seating slide gate, and on the discharge side with a positive shutoff gate and a multiple-shutter gate or a flap gate if the installation is small and a pipe is used in place of formed water passages. When formed water passages are used, transition sections between the pump and the gates sections will be needed and should be designed by the pump manufacturer.



**Total Suction Head** The practice for propeller pump installations is to dimension the station sump or sump bays in accordance with Hydraulic Institute standards and to make the distance between the sump floor and the lip of the suction bowl conform to the standards or the recommendations of the pump manufacturer. The approach and entrance velocities resulting therefrom are small enough to be disregarded when calculating total suction head. Total suction head in vertical propeller pump installations is the height from the centerline or eye of the propeller to the water surface in the sump. For drainage installations using vertical propeller pumps, a total suction head of zero is not uncommon. In submerged horizontal propeller pump installations, total suction head is the height from the centerline of the propeller shaft to the water surface in the sump, and the minimum value should be not less than  $1.2D$ , where  $D$  represents the diameter of the propeller.

Volute pumps equipped with a formed suction or suction piping may operate with either a suction lift or a suction head, depending on the suction water level. In either case, all the losses between the entrance and the eye of the impeller should be included in any calculation. Approach velocity is not a consideration in these installations, but entrance losses are.

**TOTAL SUCTION LIFT** Approach and entrance velocities can be disregarded in suction lift installations by proper dimensioning of the station sump or sump bays and by proper setting of the suction bell. The sump or sump bay dimensions used, as in suction head installations, should conform to the Hydraulic Institute standards or to the recommendations of the pump manufacturer. The suction bell for both horizontal propeller pump and vertical volute pump installations should be set with the lip located approximately  $0.5D$  above the sump floor. For horizontal propeller pump installations, the minimum submergence of the suction bell should be approximately  $0.25D$ , where  $D$  is the diameter of the suction pipe; for volute pump installations it should be  $1.5D$ , where  $D$  is the diameter of the suction bell. In determining the total suction lift for these installations, it is assumed that the suction piping is a part of the pump and that the approach and entrance velocities can be disregarded. Total suction lift therefore is the height from the water surface in the sump to the centerline of the propeller shaft or to the eye of the impeller.

**Setting** The setting of the pump or the locating of the centerline or eye of the propeller or impeller with respect to the water surface should be given careful consideration when selecting the pump to be used. Some installations offer few if any problems in this regard, whereas in others setting may have a considerable effect on the size and number of pumps selected.

**TURBINE PUMPS** Drawdown is a consideration in any well installation. In setting the pump to prevent cavitation, sufficient NPSH at the eye of the first-stage impeller and/or sufficient depth over the suction bell lip or tailpipe to prevent vortexing should be maintained when maximum draw-down is being experienced.

**VOLUTE PUMPS** Volute pumps may operate with either a suction head or a suction lift. If with a suction lift and of the horizontal type, the pump should be set above the maximum anticipated elevation of the suction water source in order to avoid inundation. As priming will be necessary when starting, a suction lift would be considered a satisfactory arrangement when long periods of continuous operation are anticipated.

Suction head installation is the preferred practice (because priming is unnecessary) and should be used whenever conditions permit. In drainage work, vertical volute pumps are used for pumping small amounts of rainfall runoff and seepage flows. These pumps are usually located in a dry sump adjacent to the storm water pump sump, with motors and valve operators located on the operating floor above. The submergence of these pumps should be such that when discharging at maximum capacity, the total suction head is zero or above. In many instances, water surface fluctuations of just a few feet occur. When small volumes are involved, a cycling operation occurs. For this type of operation, the pumps are usually started at the maximum water level and stopped at the minimum level.

**PROPELLER PUMPS** Sufficient water depth does not always exist or cannot always be provided to give the submergence needed to permit the smallest and perhaps the most efficient pump to be used. Excavation is one answer. However, depending on the soil type, the location of the installation, the kind of construction used, the silt-carrying characteristics of the stream, and the frequency of operation, excavation may be an operational and maintenance headache and is impractical when sumps are to be made self-draining. Another alternative—and the one most frequently used in drainage work—is to set the centerline or eye of the propeller at or slightly below the minimum sump elevation and select a pump that will operate at this setting with little or no cavitation damage. This means that a larger pump operating at a lower speed should be used.

**PRIME MOVERS** The prime movers used in drainage and irrigation installations are electric motors and diesel and gas engines. The one to be used in any particular situation must be determined before the pump can be selected.

*Electric motors* are the most economical installations; they should be used when a reliable source of electric power is available and when the cost of bringing it into the pumping station is not unreasonable. A reliable source of electric power is a source that historically has not suffered outages under the climatic conditions that will prevail during the time the pumps will be required to operate. Two feeders of separate origins and not subject to simultaneous outages are sometimes provided to ensure the reliability needed for drainage installations. Such an arrangement has been satisfactorily employed in urban areas but would not be a practical solution in remote areas not yet electrified. The cost of constructing and maintaining even one transmission line in such an area could be prohibitive.

The motors in all but the largest installations should be of the squirrel-cage induction type. In those installations where the motor rating is numerically larger than the speed, the type of motor used should be the one having the lowest overall first cost. It may be either a squirrel-cage induction or a synchronous motor.

All motors should be full-voltage starting except in those instances where the local power company indicates that reduced-voltage starting is necessary. For unattended operation and for drainage stations pumping seepage or pumping from a sewer system where frequent cycling is usually necessary, control devices set to start and stop the motors automatically at predetermined sump or discharge pool levels should be provided. In drainage pumping stations not subject to a cycling operation, motors are started manually by the operator and stopped automatically by a control device.

*Engines* are used to drive pumps when it is not feasible to use electric motors. They are more expensive than motors but reliable if properly maintained and serviced. They are also variable-speed drives that should be operated at constant speed whenever possible. The requirements of most installations can be met with constant-speed operation. However, for those that cannot, the number of speeds used should be held to a minimum.

Engines should not be cycled on and off but should be operated on a continuous basis. For those installations where the inflow is not sufficient, continuous operation can be obtained by returning a part of the pumped discharge back to the sump. This is accomplished by connecting the pump discharge line and the sump with a valved line.

Gas engines are seldom used, but their use should be considered when the installation is close to a natural gas main.

Right-angle reduction gears are used to transmit the power from the engine to the pump shaft of vertical propeller pumps. For horizontal pump installations where the engine shaft parallels the pump shaft but is at a different elevation and off to one side, silent chain drives are used. For other horizontal installations, parallel-shaft gear units may be used. A service of 1.50 should be used when determining the equivalent power of these units. Right-angle units should be of the hollow-shaft type only if vertical adjustment of the pump impeller is required.

Adequate fuel storage in addition to the day tanks should be provided. Storage facilities should be sufficient to provide fuel at the maximum rate of consumption for a period of 48 hours or less, as demanded by the anticipated pumping requirements. Larger fuel storage installations may be needed if replenishment supplies are not readily available. The design of the facilities should be in accordance with the standards of the National Board of Fire Underwriters and local agencies having jurisdiction.

## PUMPING STATION

---

**Sump** The sump is perhaps the most important element in the structure of the pumping station. Unless it is properly located, designed, and sized, the flow conditions within could have an adverse effect on the operation of the pump. There are many variations in sump arrangements that are acceptable; however, best results are obtained when the sumps or sump bays are oriented parallel to the line of flow. Flows approaching from an angle create dead spots and high local velocities, which result in the formation of vortices, nonuniform entrance velocities, and an increase in entrance losses. The flow to any pump should not be required to pass another pump before reaching the pump it is meant for. When sumps or sump bays are normal to the direction of flow, such as in sewer systems, the distance between the sump or sump bay entrance and the pump must be sufficient for the flow to straighten itself out before reaching the pump. For additional information relative to sump design and sizing, refer to Chapter 10. If the installation is large enough to warrant it, modeling of the sump to permit the best design to be determined is advocated.

Sumps in drainage installations pumping storm water should be either located above normal water levels, in which case they would be self-draining, or isolated from normal flows by gates. In small installations, motorized pressure-seating gates should be used; in large installations, roller gates raised and lowered with a crane or by some other suitable system should be used. These gates should be sized so the velocity through them will not exceed 5 ft/s (1.5 m/s) for any condition of flow. One gate should be located directly opposite each pump when all pumps are installed in a common sump or should be located at the entrance to each sump bay when pumps are separated.

Frequent cycling of pumps is encountered in installations that pump from sewer systems and that pump seepage. In such installations, the sump should be sized so the volume stored in it and in the ponding area or the sewer lines, as the case may be, within the limits of the operating range, will be sufficient to prevent the starting of the pumps more often than once every four minutes.

**Superstructure** A superstructure is provided on practically all drainage pumping stations but not on all irrigation pumping stations. The type of superstructure provided should be consistent with the surrounding area and should have a minimum number of windows and openings. In rural areas, corrugated sheet metal structures, which are inexpensive, have been used extensively. These provide adequate protection from the elements and from vandalism. To eliminate the need for an indoor crane, hatches in the roof over each pump can be provided to permit a truck crane to remove motors and pumps as a unit. For engine-driven pumps and larger pump installations, indoor cranes of the appropriate size and type should be provided for installation, removal, and maintenance.

**Corrosion** The corrosion of electrical and mechanical equipment in housed and unhoused stations can be controlled by painting exterior surfaces with a good paint and by installing strip heaters in all electrical enclosures. In large housed installations, heating of the operating room area in addition to the use of strip heaters should be considered. All equipment below the operating room floor level should be coated with a paint that is suitable for the exposure. In dry sump stations, enamels should be satisfactory. In wet sumps that are kept dry during inoperative periods, cold-applied coal tar enamel, which is easily repaired, is preferred. In installations where the equipment is continuously immersed, coal tar epoxy paint or vinyl paint should be used. If the water is extremely corrosive, consideration should be given to mounting galvanic anodes on the pumps in addition to painting.

## FURTHER READING

---

Department of the Army, Office of the Chief of Engineers. "Interior Drainage of Leveed Urban Areas: Hydrology." EM 1110-2-1410, Washington, DC, 1965.

Department of the Army, Office of the Chief of Engineers. "General Principles of Pumping Station Design and Layout." EM 1110-2-8102, Washington, DC, 1962.

Department of the Army, Office of the Chief of Engineers. "Mechanical and Electrical Design of Pumping Stations." EM 11102-3105, Washington, DC, 1962.

Hicks, T. G. *Pump Selection and Application*. McGraw-Hill, New York, 1957.

Houk, I. E. *Irrigation Engineering*. Wiley, New York, 1951.

Hydraulic Institute ANSI/HI 2000 Edition Pump Standards, Hydraulic Institute, Parsippany, NJ, [www.pumps.org](http://www.pumps.org).

Israelson, O. W. *Irrigation Principles and Practices*, 2d ed., Wiley, New York, 1950.

U.S. Department of the Interior, Bureau of Reclamation. *Turbines and Pumps, Design Standard 6*. Denver, CO, 1960.

---

# SECTION 9.4

---

# FIRE PUMPS

---

MARIO DI MASI  
RUDOLPH KAWOHL

Compelling reasons dictate the installation of fire protection systems driven by stationary fire pumps. Foremost among these reasons is protection—protection of lives, of equipment, possessions, and inventories, and of major assets, such as hospitals, hotels, office and residential buildings, and warehouses. There are two additional, less obvious but equally compelling, reasons: the reduction of costs and the protection of income-generating operations.

Costs are reduced in a simple manner. Over the projected life of a facility, the total of construction costs plus fire protection equipment costs plus fire insurance costs is lower than the total of construction costs plus fire insurance costs without fire protection equipment.

## **FIRE PROTECTION SYSTEMS**

---

Protection may be provided by a combination of several complementary means, acting at various levels:

- First by a simple fire detection system activating an alarm
- On the second level, the detection and warning system is combined with a first degree of fire fighting; for example, with a *sprinkler installation*, the role of which is to extinguish the fire at the beginning or, at least to limit its extension so as to permit intervention with additional equipment
- The third level is a combination of detection, warning, sprinkler and extinguishing systems (water, inert gases, foam)

The degree of protection is obviously a function of risk. Whereas a fire in a single-family-dwelling may be warned by phone and then efficiently contained by means of fire hydrants or fire fighting trucks, the risk of fire in a chemical plant requires a completely

different approach. The rules for adequate protection vary from one country to another. There are, for instance, well known pamphlets published by the U.S. National Fire Protection Association (NFPA). In Europe, various national rules exist, based on the recommendations of the European Committee of Insurances, such as those of APSAD in France (Assemblée Plénière des Sociétés d'Assurances Dommages), V d S in Germany (Verband der Sachversicherer e;v), and LPC in the United Kingdom (Loss Prevention Council).

### **FIRE PUMP CRITERIA**

The most common liquid available for fire protection and fire fighting continues to be water. The efficiency of a fire fighting installation depends to a great extent on a dependable water supply, which will supply the required flow at the required pressure and be continuously available during the time necessary to extinguish the particular type of fire in question.

The needs for fire fighting liquid vary considerably with the degree of danger involved. When these needs cannot be satisfied from local water sources, such as public water networks, high level reservoirs, or pressurized water tanks, pumping stations need to be designed and situated (located) to address the types of fire possible and the national codes and standards that exist in a particular country or geographical area.

A typical fire fighting station may be composed of the following:

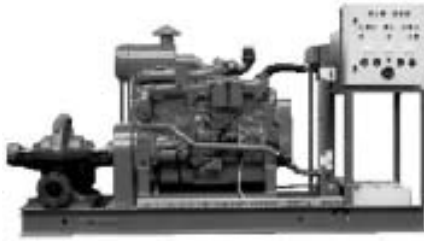
- A jockey pump (Figure 1) that maintains the desired system pressure within the fire fighting system. Typical performance for a jockey pump is 10 gpm (38 l/min) at heads up to 300 ft (92 m).
- A first intervention fire fighting pump (Figure 2) capable of feeding a limited number (up to 5) of sprinklers. This pump is typically driven by an electrical motor and is fed from a reservoir capable of supplying at least one hour of liquid flow without interruption at required flow and pressure. Records indicate that as many as 95% of all fires are extinguished by this first intervention pump. Typical performance for a first intervention pump is 250 gpm (950 l/min) at a head of 200 ft (60 m).
- An emergency fire fighting pump, capable of feeding all available sprinklers, and other supplementary fire fighting equipment, such as deluge installations and fire-hose nozzles. This pump is typically driven by a diesel engine and supplied with fire fighting water from a (practically) inexhaustible source. The emergency fire fighting pump standard in North America is a split case pump (Figure 3), whereas the European standard is an end suction pump (Figure 4). In each case, typical pump performance is from 500 to 5000 gpm (100 to 1200 m<sup>3</sup>/h) at a head of 260 ft (80 m).
- High-rise buildings, protected by sprinklers or standpipes and hose systems, require an overpressure pump. This pump is generally a close coupled end suction pump (Figure



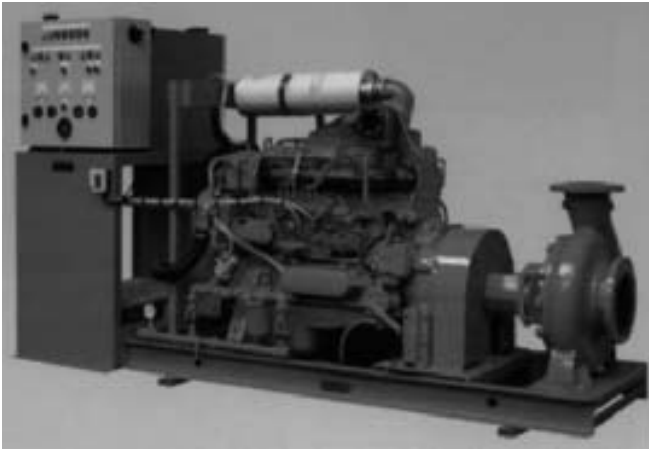
**FIGURE 1** Jockey pump (Flowserve Corporation)



**FIGURE 2** First intervention fire pump (Flowserve Corporation)



**FIGURE 3** Split case fire pump (Flowserve Corporation)



**FIGURE 4** End suction fire pump (Flowserve Corporation)



**FIGURE 5** Close-coupled end suction fire pump (Flowserve Corporation)

5) driven by an electrical motor, with typical performance of 150 gpm (34 m<sup>3</sup>/h) and a head (according to the building height) of at least 200 ft (60 m), sourced from a public water network.

Although the various national authorities have different approaches to the details of fire fighting equipment and arrangement, they nevertheless have a similar basic philosophy. The pumps utilized in fire protection systems are usually classical designs. Specifications require skillful packaging of the complete fire protection system, including the pump(s), driver(s), starting and control devices and other accessories.

Most European codes give considerable freedom of choice relative to pump type and design, whereas NFPA 20 (United States) is more restrictive. According to NFPA, the pumps must be of horizontal end-suction or horizontal split-case design. Single stage close coupled vertical in-line pumps may be used for limited capacities, but these pump types may not be used where a static suction lift is required. If the pump must lift water from a well, panel, river, and so on, NFPA 20 requires the use of vertical pumps installed so the static water level is never below the bottom impeller.

Very high importance is given in all regulations to permanent availability of fire fighting water. Pumps must always be filled with water and must be ready for starting at any moment. This requirement is obviously satisfied when NFPA 20 compliance is mandatory. Although the same approach is preferred in Europe, some European codes nevertheless allow the use of horizontal pumps with a static suction lift. In such cases, the suction pipe must be fitted with a foot valve, and the pump set must be equipped with a controlled filling device.

Some rules common to both North America and Europe are

- The shape of the pump performance curves must conform to precise specifications.
- The design pressure of the pump casings is regulated.
- Hydrostatic tests are required.
- Certified performance test curves are required for most fire pumps.
- Fire fighting pumps must be approved, “de jure” (according to written law or regulations) in North America and in most European countries; “de facto” (according to well-established practices) in the others.

Stationary fire pumps can be purchased as packaged systems, which saves installation time and money. Single or multiple units of horizontal or vertical pumps can be packaged, and each packaged unit generally includes the pump(s), driver(s), controller(s), headers, accessories, and piping mounted on a common base. To the extent possible, all wiring and piping connections are made and the unit is factory-tested. Installation consists simply of positioning and leveling the package and making external piping and electrical connections.

## **FIRE PUMP DRIVERS**

---

The principal objective of a fire pump driver is to provide the pump with motive power under any circumstances. Usual drivers are electric motors, diesel engines or, to a lesser extent, steam turbines. Although the reliability of the drivers themselves does not really pose problems, careful consideration must be given to the dependability of the power supply for electric motors and turbines, and to the fuel supply for diesel engines. Very complete regulations exist in every country which must be considered.

Electric motors are the most economical driver type when a reliable power source is available. If this is not the case, power must be supplied by two or more independent sources, one of which may be an emergency generator set. Another choice might be to use one motor-driven pump and one diesel engine-driven pump. General guidelines for electric drives are

- Motor power and speed must be selected in accordance with the pump characteristics.
- Depending upon codes and available current, wound rotor, star delta, wye delta primary resistance, or part-winding start motors may be used.

Diesel engines are frequently used to drive stationary fire pumps. Equipped with battery packs and automatic controls, they rival electric motors for reliability and eliminate concern over the dependability of the source of electric power. In order to guarantee the fuel supply, the tank must be located above ground at an appropriate height. The prevail-



ing philosophy of a diesel engine driven pump is that “the pump must run” in actual fire conditions. All engine failures (oil pressure, cooling water temperature, speed) should be indicated only, and should not stop the engine. The only exception to this is the NFPA 20 requirement that a shut-down occur at an over speed of 120%.

Here are some general guidelines for diesel engines:

- Engine power and speed must be selected in accordance with the pump characteristics (diesel engines are very sensitive to altitude and ambient temperature).
- All energy sources for engine starting must be doubled: two batteries, or two air containers, or electrical and manual recharge of the hydraulic starting system, and so on.
- An instrument panel secured to the engine at an appropriate place must include a tachometer, an hour meter, an oil pressure gage, and a water temperature gage.

Occasionally, a fire pump is driven by a steam turbine. When it is desirable to use steam as the power source, details of the steam supply and exhaust need to be carefully planned to ensure that the required level of reliability exists.

### **FIRE PUMP CONTROLLERS**

---

Regardless of the type of driver, most fire pumps are started automatically by a pressure signal from the pump discharge line. Each fire pump must have its own controller, including the jockey pump.

Depending upon application requirements, fire pump electric motor controllers must conform to the appropriate national regulations. Each controller must be arranged to match the starting characteristics of its motor and must include

- Manual disconnect switch
- Circuit breaker
- Starter without heaters or contactors
- Pressure switch (when NFPA is mandatory)
- Minimum-run timer to prevent motor cycling

The diesel engine controller is arranged to permit either automatic or manual start. The manual start is required to permit periodic run tests. The power source for the controller and for starting is a dual set of batteries or air containers. The controller is arranged to show the following engine conditions:

- Low lubrication oil pressure
- High water jacket temperature
- Failure to start automatically
- Shut-down due to overspeed (when NFPA 20 is mandatory)
- Battery and battery charger failure or, when equipped with one, an air system failure

The engine controller must also provide a means of relaying the following information to remote indicators:

- Engine running
- Engine switch off or manual position
- Trouble signal (activated by one or any combination of the engine or controller signals described above)

Approval of the control system for all pumps, except the jockey pump, is required in nearly all national codes.

## GENERAL ENGINEERING PROCEDURE FOR FIRE PROTECTION SYSTEMS

As described earlier, fire protection systems can vary greatly depending on the type and significance of the fire risk, the site conditions and, finally, the various national regulations in force in the given country. Outlined below are engineering guidelines for stationary installations using water as protection agent. Figures 6 and 7 show typical installations for horizontal and vertical fire pumps.

Here are some project basics to keep in mind:

1. Refer to an insurance expert, or to a specialist of a certification board, to confirm that water may be used for the risks of concerned and to determine which kind of spray system is recommended: sprinklers, water jets, deluge installations, and so on.

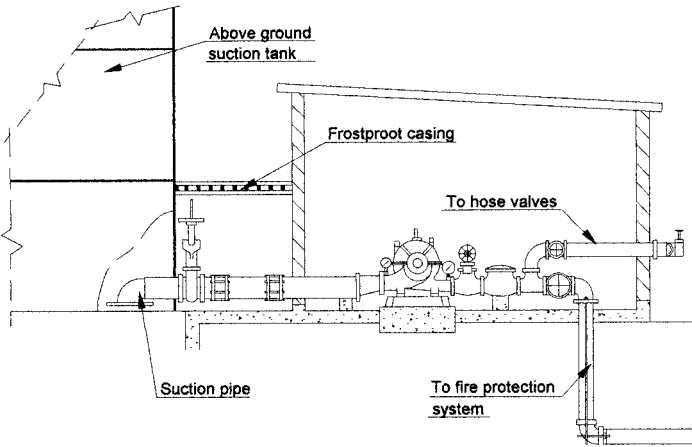


FIGURE 6 Typical installation for horizontal fire pumps

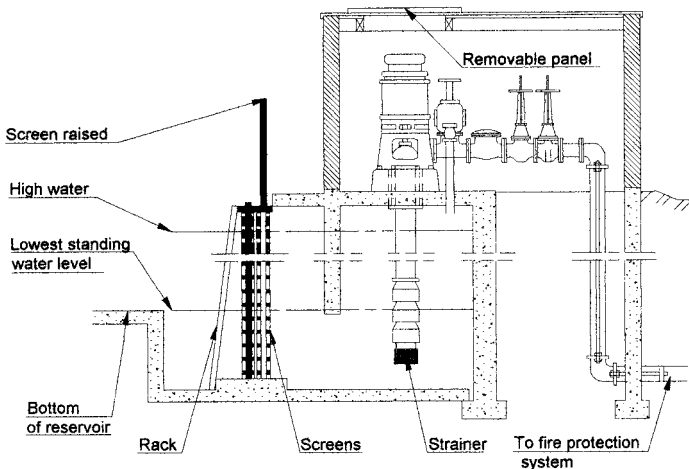


FIGURE 7 Typical installation for vertical fire pumps

2. Determine the appropriate governing regulations: NFPA (North America), APSAD (France), VDS (Germany), and so on.
3. Ensure the availability of sufficient water capacity, according to the type of risk. Preference should be given to a water supply above ground, which is generally more reliable and less expensive than a below-ground supply.
4. Distinguish all the critical areas and functions to be protected on the site.
5. Determine the motive power of the pump drivers. The objective is to be independent from the site of risk. Diesel engine-driven installations many times provide a convenient, independent power source that addresses this concern. The costs associated with a diesel engine power source is usually equivalent to those of electrical installations; in some cases, they are even lower.
6. Provide a pump house, or a pump room, so the pump, driver and controller may be protected against possible damage or injury. In addition to the normal precautions and concerns of a pump installation, also consider the following factors:
  - Easy access for installation and maintenance
  - Sufficient ventilation for motors and engines
  - Risk of earthquakes
  - Risk of freezing
  - Noise protection, where required
7. Determine the pipe network and all required fittings and accessories in order to obtain the lowest project costs.
8. Smaller pipe sizes (less expensive) increase friction losses and may require more powerful (more expensive) pump sets.
9. Larger pipe sizes (more expensive) decrease friction losses and may allow the use of less powerful (less expensive) pump sets.

Keep in mind the following factors when selecting a pump:

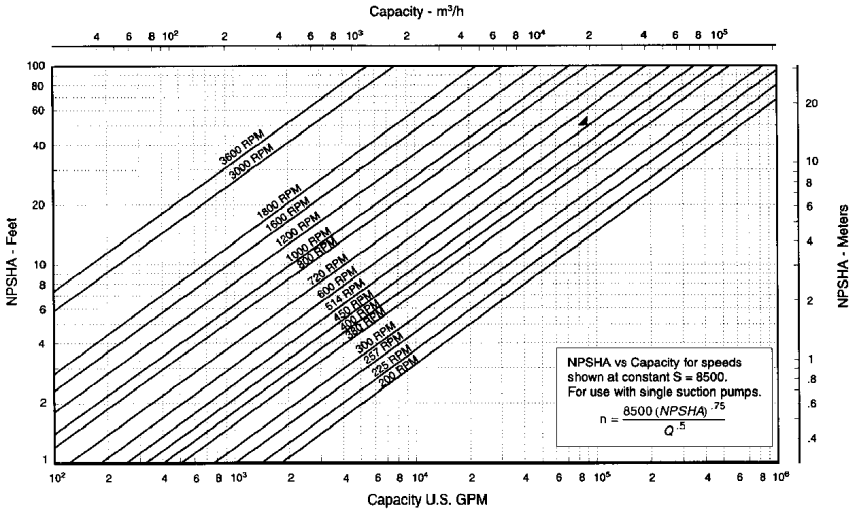
1. Compute the total capacity and pressure required to feed the protection system.
2. Determine the *NPSH* available at the pump suction nozzle. This is an important selection criterion for establishing the speed and design of the pump. Reminder: U.S. regulations forbid static suction lifts for fire pumps, whereas most European regulations will allow limited suction lifts.
3. Select the highest possible pump speed based on the required capacity and the available *NPSH*. The higher the allowable pump speed, the lower the cost of the pump set. Figures 8 and 9 give recommended operating speeds for single suction and double suction pumps.
4. Select pump size and design according to the governing (applicable) regulations.

**Drivers and Controllers** As outlined earlier under “Fire Pump Criteria,” it is recommended that a completely packaged fire pump set, including the pump(s), driver(s), controller(s), headers, accessories and piping, mounted on a common base, be furnished.

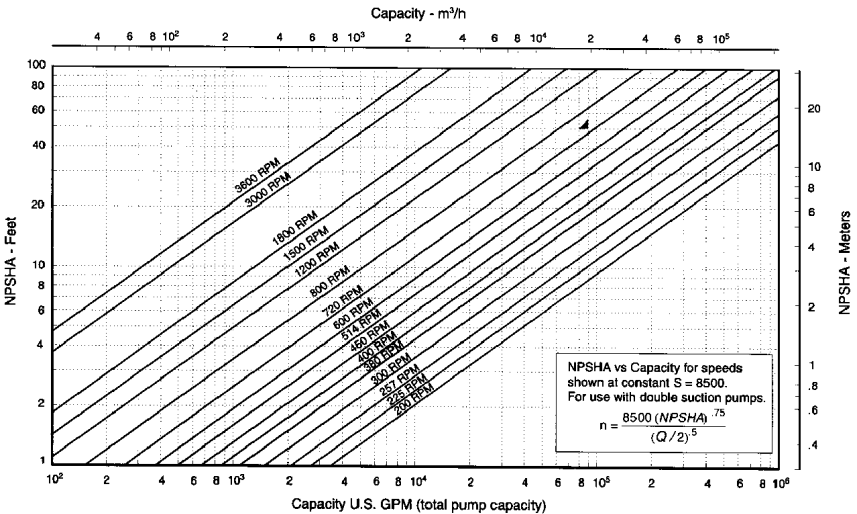
## **PUMP DESIGN AND MATERIALS**

---

Constant operational readiness and a high degree of operational reliability are the most important aspects of fire pump designs. Although not mandatory, the features listed and described next are recommended for fire pumps.



**FIGURE 8** Recommended operating speeds for single suction fire pumps (Hydraulic Institute ANSI/HI 2000 Edition Pump Standards, Reference 1)



**FIGURE 9** Recommended operating speeds for double suction fire pumps (Hydraulic Institute ANSI/HI 2000 Edition Pump Standards, Reference 1)

- Shaft sealing should be by means of stuffing boxes (packing).
- Grease-lubricated rolling element bearings should be used on horizontal pumps. Water-lubricated (rubber) sleeve bearings (open line shaft) or oil-lubricated bronze sleeve bearings (enclosed line shaft) and, if so equipped, a grease-lubricated thrust bearing should be used on vertical pumps.
- Combinations of materials, running clearances, and rotor end plays should permit trouble-free operation, even if the pump has been idle (not run) for extended periods of time.

- Repairs should be achievable by means of standard tools.
- Corrosion-resistant materials must be utilized if the fire-fighting water is corrosive, such as brackish or salt water.
- Additional features or specific materials, as may be mandated by specific national standards and codes.

Because most fire pumps handle clear water, and because wear (from severe usage) is not usually a problem, fire fighting pumps should be of the simplest design possible and should be made of commonly used industrial materials. The most economical fire pump is either a single-stage, end suction, or vertical in-line pump. This class of pump is readily available to heads of approximately 260 ft (80 m). Unfortunately, capacities have been limited in the United States (by NFPA 20) to 750 gpm (200 m<sup>3</sup>/h) for horizontal end suction pumps and to 500 gpm (115 m<sup>3</sup>/h) for vertical in-line pumps. The 1996 edition of NFPA 20 eliminated these historical limitations. In Europe, however, end suction volute pumps are commonly employed up to 4000 gpm (900 m<sup>3</sup>/h).

The jockey pump (Figure 10), used to maintain the pressure within the system, is generally a small, vertical multistage pump, utilizing an extended motor shaft (no shaft coupling). Recommended materials for jockey pumps are

Casings:	Cast iron
Impellers:	Bronze or thermoplastic resin
Diffusers:	Cast iron
Shaft:	Chromium steel
Bearings:	Grease lubricated rolling element bearings, with an additional product lubricated bronze line bearing in close coupled designs

A large end suction fire fighting pump, as shown in Figure 11, is typical of units used in Europe and allowed to be operated over the entire pump capacity range, from shut-off to the highest capacities. The pump exhibits the following features:

- Back pull out construction for ease of maintenance without disturbing the driver
- The absence of shaft sleeves, giving highest possible shaft stiffness

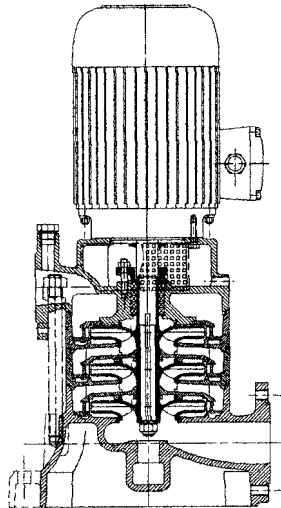


FIGURE 10 Small, vertical multistage jockey pump using an extended motor shaft (Flowserve Corporation)

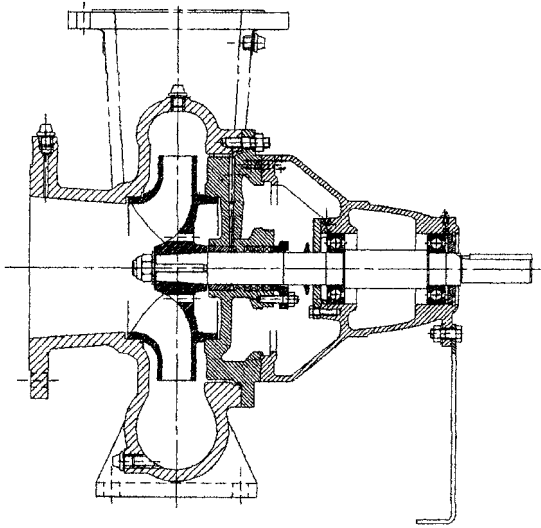


FIGURE 11 Large end suction fire pump, typical of units used in Europe (Flowsolve Corporation)

- A bronze bearing bushing located behind the impeller that acts as a product lubricated auxiliary line bearing
- A conical (tapered shaft) impeller fit to ensure no looseness between the mounted impeller and the shaft (critical when pumps are driven by a diesel engine)

Recommended materials for end suction fire fighting pumps are

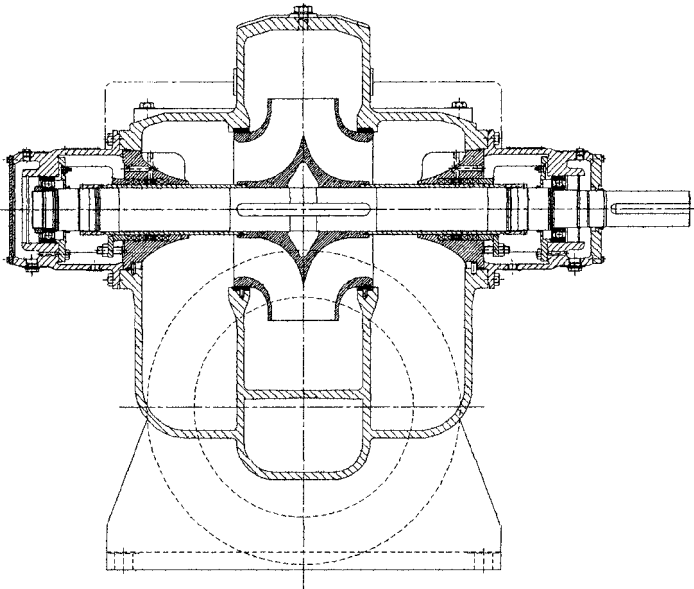
Casing:	Cast iron or ductile iron
Impeller:	Bronze
Shaft:	13% chromium steel
Bearings:	Grease-lubricated rolling element bearings

For larger capacities, in excess of 500–750 gpm (115–200 m<sup>3</sup>/h) in the United States and above approximately 4000 gpm (900 m<sup>3</sup>/h) in Europe, single stage double suction axially split case pumps (Figure 12) are required. These larger units are more costly than the simple single stage overhung designs, but they do offer some advantages that could make them desirable even at lower flow rates, such as

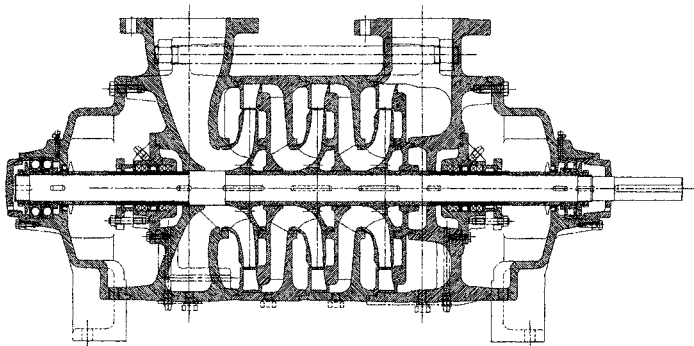
- The required *NPSH* is lower (double suction impeller), thus allowing higher operating speeds.
- The axially split case design provides easy access to the pump interior (neither the pump nor the driver need to be disconnected) for inspection and rotor removal.
- Axially balanced hydraulic axial forces, and bearings on each end of the rotor supports unbalanced radial loads.

Recommended materials for single stage double suction axially split case for fighting pumps are

Casing:	Cast Iron
Impeller:	Bronze
Shaft:	Carbon steel



**FIGURE 12** Single stage double suction axially split case pump used for larger capacities (FlowsERVE Corporation)



**FIGURE 13** Multistage ring-section fire pump (FlowsERVE Corporation)

Sleeves:	Bronze
Casing Rings:	Bronze
Bearings:	Grease-lubricated rolling element bearings

Normally, head requirements for fire pumps do not exceed 260 ft (80 m). For those systems that do require more head, end-suction and axially split case pumps may be available up to 450 ft (140 m). Beyond this head range, multistage pumps are typically employed. Multistage pumps for fire services in Europe are usually of the ring-section design (Figure 13), whereas the axially split case design (Figure 14 shows a typical two-stage pump; Figure 15 shows a typical multistage pump) tends to be more popular in North America.

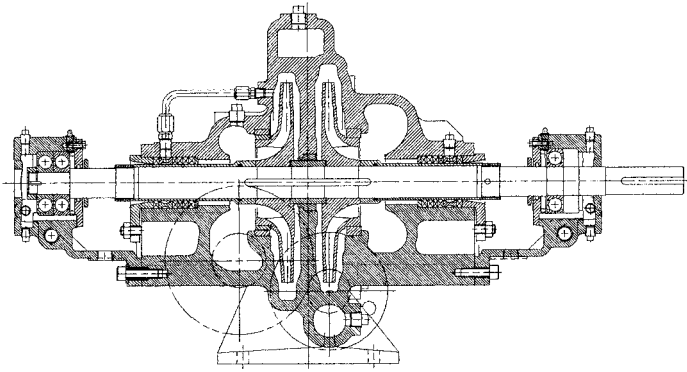


FIGURE 14 Two-stage axially split fire pump (Flowserve Corporation)

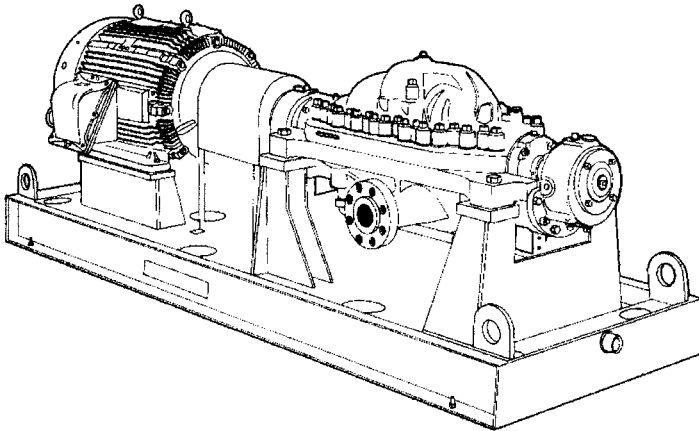


FIGURE 15 Typically axially split multistage pump used for fire fighting (Flowserve Corporation)

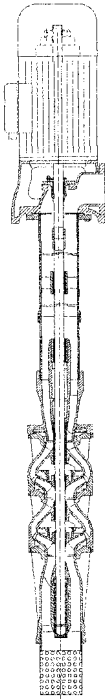
In North America, vertical pumps must be used when the water source is located below ground. In Europe, where the use of a limited static suction lift is generally permitted, such vertical pumps are required only when the *NPSH* available at the suction nozzle of a horizontal pump would exceed a certain limit, as may be established by national regulations in each country—for instance 16.4 ft (5 m) in France.

The submergence of vertical pumps require a particular care. As a minimum, the second stage (second impeller up from the bottom end of the pump) should always be submerged below the minimum water level.

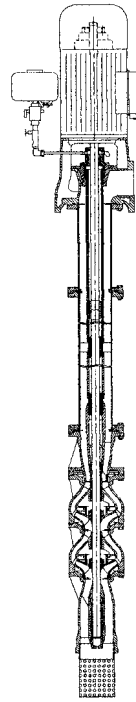
The inner column (drive shafting) for vertical pumps is available in either of two configurations:

- Open line shaft (OLS) construction (Figure 16), within which a steel shafting rotates in water-lubricated rubber bearings, centered and stabilized by rigid bearing retainers, is used for static water levels 50 ft (15 m) or less below the pump discharge flange.





**FIGURE 16** Vertical pump with open line shaft construction (Flowserve Corporation)



**FIGURE 17** Vertical pump with enclosed line shaft construction (Flowserve Corporation)

- Enclosed line shaft (ELS) construction (Figure 17), in which steel shafts rotate in oil-lubricated bronze sleeve bearings, is used for static water levels of more than 50 ft (15 m). In ELS construction, the outside of the sleeve bearings are threaded and tubes enclosing and supporting the bearings and shafts isolate the shafting from the water being pumped.

If an oil-lubricated line shaft design is utilized, the appropriate environmental protection or health department should be consulted with regard to special requirements for installation and protection.

Recommended materials for vertical pumps are

Discharge head and columns:	Cast iron or welded steel
Water-lubricated line shaft:	Carbon steel protected by non-rusting shaft sleeves through packing and water-lubricated bearings (Note: chromium steel shafts typically do not require shaft sleeve protection.)
Oil-lubricated line shaft:	Carbon steel possible, but chromium steel is preferred
Pump shaft:	Chromium steel
Bowls:	Cast iron
Impellers:	Bronze

**OVERVIEW OF COMMONLY USED ACCESSORIES**

See Figures 18 and 19 for typical fire pump systems.

1. Common to horizontal and vertical pumps:

- a. **Casing relief valve** To prevent a no-flow condition when system is running at shutoff

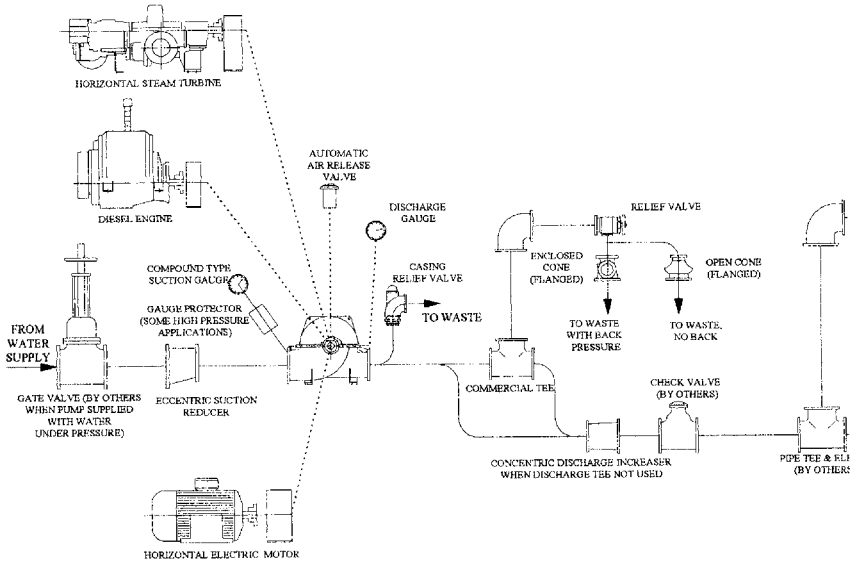


FIGURE 18 Typical horizontal fire pump system

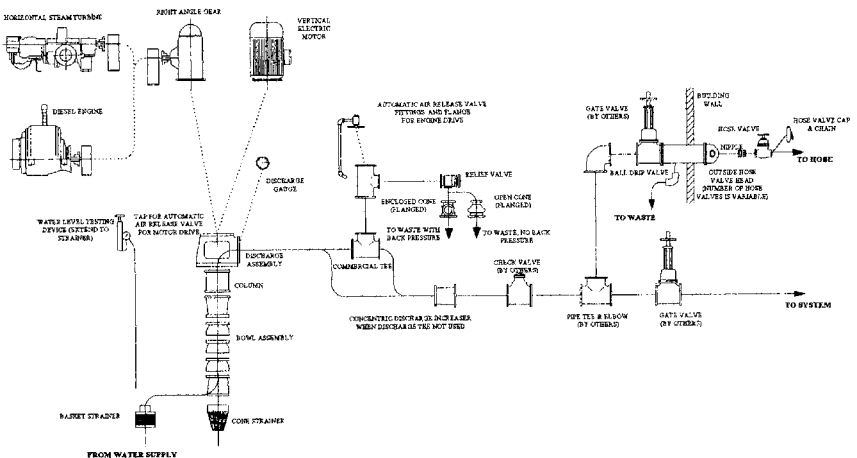


FIGURE 19 Typical vertical fire pump system

- b. Automatic air release valve** To vent entrapped air in automatic systems
  - c. Umbrella cock** To vent air in manually operated systems
  - d. Hose valve head with hose valves, caps, and chains** To permit pump flow (capacity) tests (most modern systems use flowmeters in lieu of hose valve heads)
  - e. Ball drip valve** Installed upstream to prevent freeze damage to hose valve head installed outside
  - f. Overflow cone** To show whether the relief valve is open
  - g. Commercial discharge tee with (if required) 90° elbow** Used when main relief valve is required
2. Horizontal pumps only
- a. Eccentric suction reducer** Required when the size of the suction pipe does not match the size of the pump suction connection
  - b. Concentric discharge increaser** Required when the size of the discharge pipe does not match the size of the pump discharge connection
  - c. Main relief valve** Required when pump shutoff pressure plus suction pressure exceeds system design pressure and when engine or other variable-speed driver is used
  - d. Splash partition** Used for motor-driven units where hose head are mounted indoors near pump
3. Vertical pumps only
- a. Main relief valve** Required when engine or other variable-speed driver is used
  - b. Water level testing device** To determine distance to surface of water; required for well pump installations

## REFERENCES AND FURTHER READING

---

### United States

1. American National Standard for Centrifugal Pumps for Design and Application, ANSI/HI 1.3-2000, Section 1.3.4.1.15, Hydraulic Institute, Parsippany, NJ [www.pumps.org](http://www.pumps.org).
2. Factory Mutual Research Corporation, "Approved Guide/Fire Protection—A Guide to Equipment Materials and Services." 1151 Boston-Providence Turnpike, Norwood, MA 02062.
3. National Fire Protection Association. *National Electrical Code*, NFPA 70. 1 Batterymarch Park, PO Box 9101, Quincy, MA 02269-9101.
4. National Fire Protection Association. *Standard for the Installation of Centrifugal Fire Pumps*, NFPA 20, 1996 ed., 1 Batterymarch Park, PO Box 9101, Quincy, MA 02269-9101.

### France

5. "Extinction Automatique A Eau, Type Sprinkler, Regle d'Installation." APSAD, 26 Boulevard Haussmann, 75311 Paris Cedex 09.

### Germany

6. "Rules for Water Extinguishing Systems." VdS—Schadenverhütung, Amsterdamer Strasse 174, 50735 Köln.

### Italy

7. "Norma italiana UNI 9490, Apparecchiature per estinzione incendi." Uni-Ente Nazionale Italiano Di Unificazione, Via Battistotti Sassi, 11b, 20133 Milano.

**United Kingdom**

8. "Approved Fire Security Products and Services 1995." The Loss Prevention Certification Board Limited, Melrose Avenue, Borehamwood, Hertfordshire WD6 2 BJ.
9. Borland, G. S., and Greig, A. "Fire Pumps for the Oil and Gas Industry." *ImechE*, C108/87, 1987.
10. Lingenfelder, G., and Shank, P. "Fire Pump Systems—Design and Specification." *Pumps and Systems Magazine*, August 1998.

---

# SECTION 9.5

---

# STEAM POWER PLANTS

---

IGOR J. KARASSIK  
RICHARD P. KOCH

---

## STEAM POWER PLANT CYCLES

---

Power is produced in a steam power plant by supplying heat energy to the feedwater, changing it into steam under pressure, and then transforming part of this energy into mechanical energy in a heat engine to do useful work. The feedwater therefore acts merely as a conveyor of energy. The basic elements of a steam power plant are the heat engine, the boiler, and a means of getting water in the boiler. Modern power plants use steam turbines as heat engines; except for very small plants, centrifugal boiler-feed pumps are used.

This basic cycle is improved by connecting a condenser to the steam turbine exhaust and by heating the feedwater with steam extracted from an intermediate stage of the main turbine. This results in an improvement of the cycle efficiency, provides deaeration of the feedwater, and eliminates the introduction of cold water into the boiler and the resulting temperature strains on the latter. The combination of the condensing and feedwater heating cycle (Figure 1) requires a minimum of three pumps: the condensate pump, which transfers the condensate from the condenser hot well into the direct-contact heater; the boiler-feed pump; and a circulating pump, which forces cold water through the condenser tubes to condense the exhaust steam. This cycle is very common and is used in most small steam power plants. A number of auxiliary services not illustrated in Figure 1 are normally used, such as service water pumps, cooling pumps, ash-sludging pumps, oil-circulating pumps, and the like.

The required improvements in operating economy in the 1970s dictated further refinements in the steam cycle, and these created new demands for power plant centrifugal pumping equipment. This evolution involved a steady increase in operating pressures until 2400 lb/in<sup>2</sup> (165 bar\*) steam turbines became quite common. Many plants are operating at supercritical steam pressures of 3500 lb/in<sup>2</sup> (240 bar). Several central station

\*1 bar = 10<sup>5</sup> Pa.

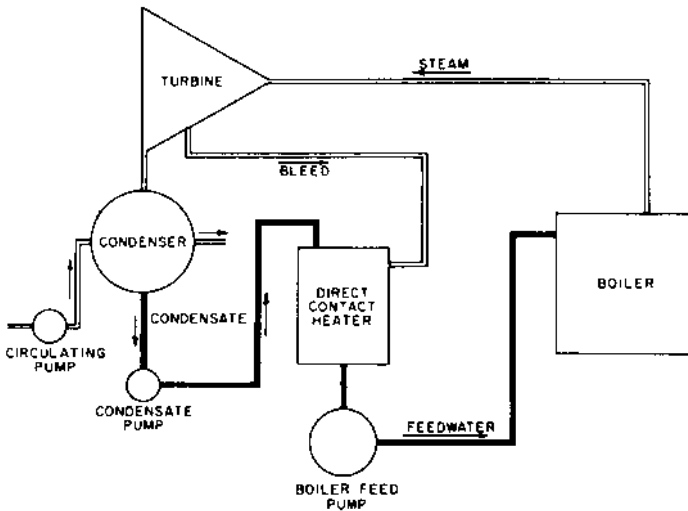


FIGURE 1 Simple steam power cycle

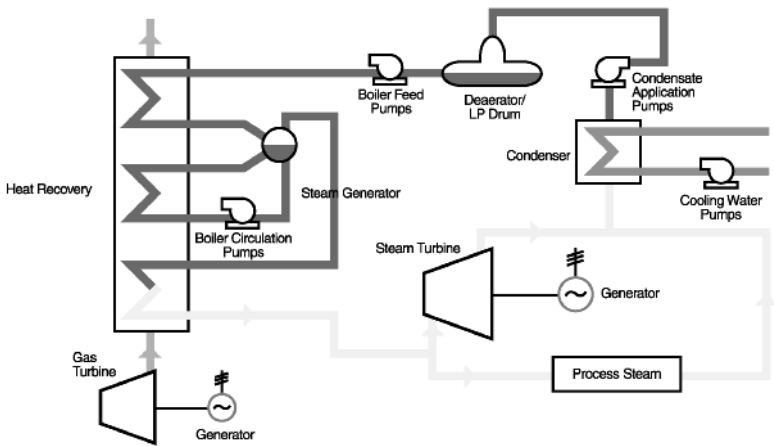


FIGURE 2 Natural gas and steam, combined cycle power

plants constructed in the late 1970s are operating between 4000 and 5000 lb/in<sup>2</sup> (275 and 345 bar).

Other refinements were directed toward a greater utilization of heat through increased feed-water heating, introducing a need for heater drain pumps—equipment with definite problems of its own. Finally, the introduction of forced or controlled circulation as opposed to natural circulation at 650°F (343°C) in boilers created a demand for pumping equipment of again an entirely special character.

Although direct-contact heaters would have thermodynamic advantages, a separate pump would be required after each such heater. The use of a group of closed heaters permits a single boiler feed pump to discharge through these heaters and into the boiler. The average power plant is based on a compromise system: one direct-contact heater is used for feedwater deaeration, whereas several additional heaters of the closed type are located

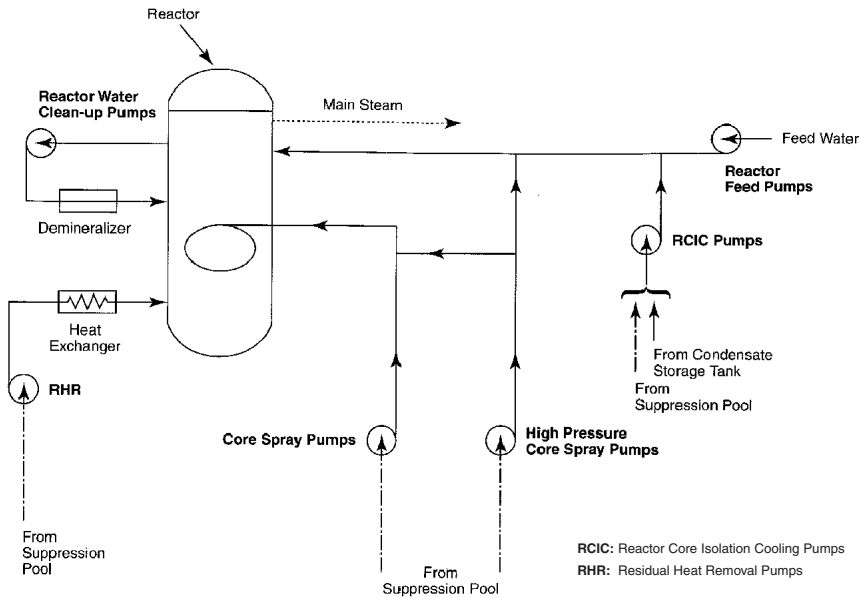


FIGURE 3 Nuclear power steam cycle, boiling water reactor

upstream as well as downstream of the direct-contact heater and of the boiler-feed pump (Figure 5). Such a cycle is termed an *open cycle*. The major variation is the *closed cycle*, where the deaeration is accomplished in the condenser hot well and all heaters are of the closed type (Figure 6).

Electric power generation technology advanced into the 1970s when the conventional coal and gas fired boilers were replaced with nuclear fission reactors. Nuclear power generation utilizes two concepts for generating steam: boiling water reactors (Figure 3) where the feedwater travels directly to the reactor, and pressurized water reactors (Figure 4) where the feedwater travels through a steam generator.

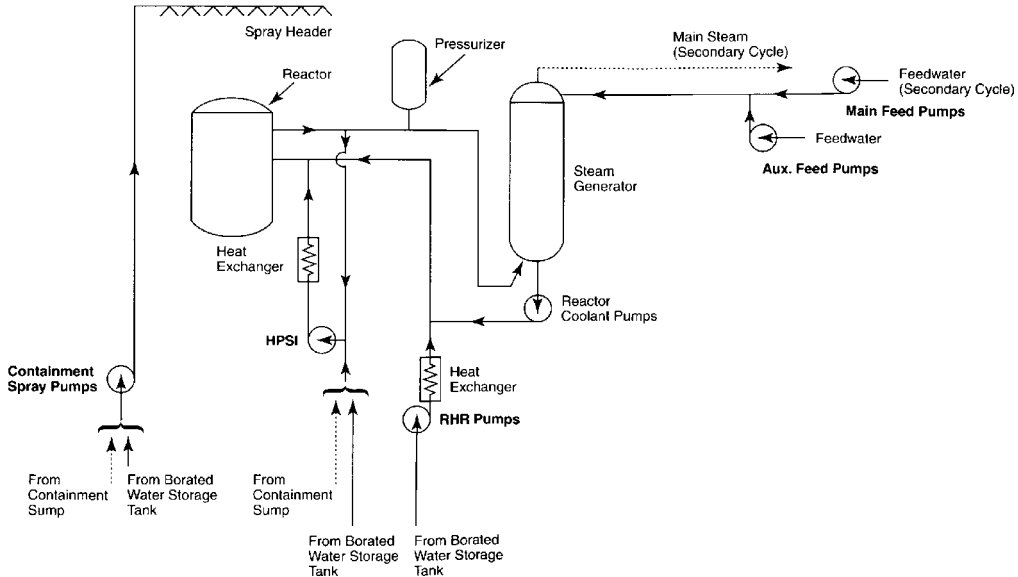
In the 1980s, the evolution of power generation industry continued with the construction of combined-cycle units. This technology increased the efficiency and improved the heat rate by utilizing the exhaust gases of primary gas turbines to produce valuable steam to drive steam-powered generators (Figure 2). Gas turbine-fired plant construction expanded as emphasis increased on environmental issues related to coal- and oil-fired plants.

## STEAM POWER PLANT PUMPING SERVICES

Pumps are very important components of a steam electric power plant. The major applications are the condensate, boiler-feed, heater drain, and condenser circulating pumps. The all-inclusive category of "miscellaneous pumps" includes such a variety of services that it merits being broken down into its components and included in a representative listing. Table 1 provides such a listing for conventional (fossil fuel) steam power plants. The list is not necessarily complete but is reasonably representative.

## BOILER-FEED PUMPS

Under the term *conditions of service* are included not only the pump capacity, discharge pressure, suction conditions, and feedwater temperature but also the chemical analysis of



RHR: Residual Heat Removal Pumps  
 HPSI: High Pressure Safety Injection Pumps

FIGURE 4 Nuclear power steam cycle, pressurized water reactor



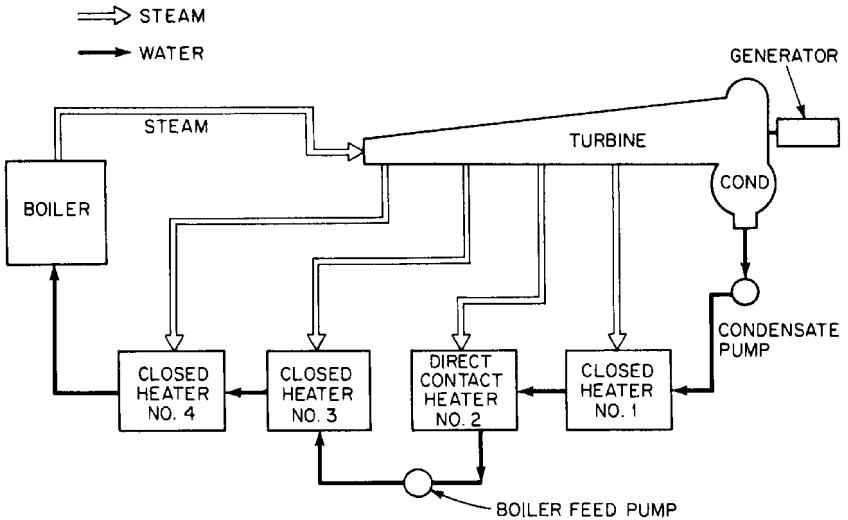


FIGURE 5 Open feedwater cycle with one deaerator and several closed heaters

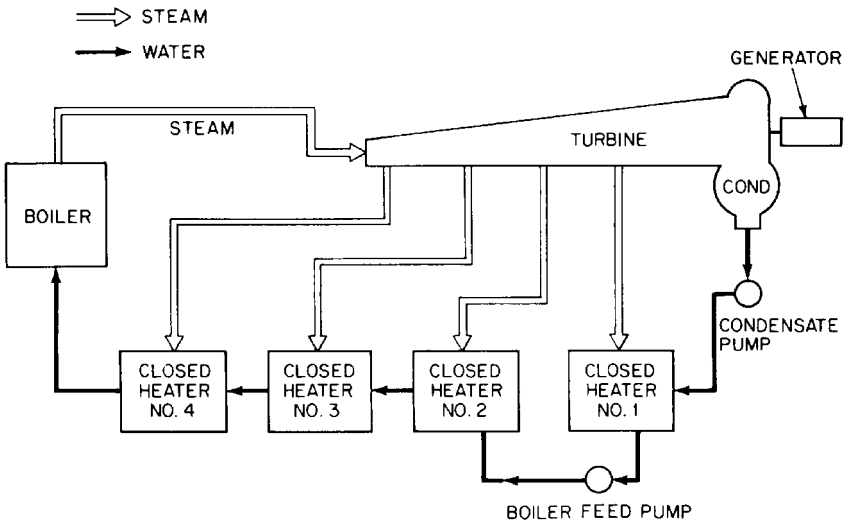


FIGURE 6 Closed feedwater cycle

the feedwater, the pH at pumping temperature, and other pertinent data that may reflect upon the hydraulic and mechanical design of the boiler-feed pumps. Preferably, a complete layout of the feedwater system and of the heat balance diagram should be supplied to the boiler-feed pump manufacturer. The study of this layout will often permit the manufacturer to suggest an alternate arrangement of the equipment that would result in a more economical operation, in a lower installation cost, or even in longer equipment life to reduce the eventual maintenance expense.

**TABLE 1** Pump services in conventional steam power plants

Turbogenerator and auxiliaries	Fuel oil system (continued)
Condenser circulating pumps	Low-temperature oil-circulating pumps
Screen wash-water pumps	Distillate oil unloading pumps
Cooling tower make-up pumps	Fuel oil additive unloading pumps
Steam generator equipment	Fuel oil additive transfer pumps
Condensate pumps	Fuel oil additive metering pumps
Condensate booster pumps	Fuel oil hose drain pumps
Boiler-feed pumps	Lubricating oil system
Boiler-feed booster pumps	Lubricating transfer pumps
Deaerator make-up pumps	Starting oil pumps
Heater drain pumps (low and high pressure)	Main oil pumps
Chemical feed system	Emergency oil pumps
Amine pumps	Centrifuge feed pumps
Hydrazine pumps	Fire protection system
Phosphate pumps	Fire pumps
Caustic feed pumps	Jockey pumps
Acid feed pumps	Foam proportioning pumps
Ammonia pumps	Heating, ventilating, and air conditioning system
Regeneration waste pumps	Hot water circulating pumps
Deminerlizer pumps	Chilled water pumps
Neutralizing metering pumps	Service water system
Neutralizing tank sump pumps	Service water pumps
Acid bulk-transfer pumps	Air preheater wash pumps
Caustic bulk-transfer pumps	Cooling water booster pumps
Inlet and effluent deminerlizer waste tank pumps	Primary air heating coil condensate return pumps
Fuel oil system	Heating drain tank return pumps
Fuel oil transfer pumps	Sump pumps
Secondary fuel oil pumps	Closed cooling water system pumps
Secondary fuel oil heater drip pumps	Miscellaneous
Ignitor oil pumps	Ash sluice pumps
Auxiliary boiler fuel pumps	Slurry pumps
Warm-up oil pumps	Acid cleaning pumps
High-temperature oil-circulating pumps	Hydrostatic pressure test pumps

**Boiler-Feed Pump Capacity** The total boiler-feed pump capacity is established by adding to the maximum boiler flow a margin to cover boiler swings and the eventual reduction in effective capacity from wear. This margin varies from as much as 20% in small plants to as little as 5% in the larger central stations. The total required capacity must be either handled by a single pump or subdivided between several duplicate pumps operating in parallel. Industrial power plants generally use several pumps. Central stations tend to use single full-capacity pumps to serve turbogenerators up to a rating of 100 or even 200 MW and two pumps in parallel for larger installations. There are obviously exceptions to this practice: some engineers prefer the use of multiple pumps even for small installations, whereas single steam-turbine-driven boiler-feed pumps designed for full capacity are installed for units as large as 1300 MW (Figure 7). A spare boiler-feed pump is generally included in industrial plants. The trend in combined cycle cogeneration plants is to install two 100% capacity pumps. This provides optimum reliability and availability. Combined cycle plants are equipped with multiple feedwater pump arrangements related to the gas turbine exhaust stage pressure. Installation variations include high pressure intermediate pressure (often a stage take-off from the high pressure pump) and the low pressure feedwater pumps.

**Suction Conditions** The net positive suction head (*NPSH*) represents the net suction head at the pump suction, referred to the pump centerline, *over and above* the vapor pressure of the feedwater. If the pump takes its suction from a deaerating heater, as in Figure 5, the feedwater in the storage space is under a pressure equivalent to the vapor pressure corresponding to its temperature. Therefore the *NPSH* is equal to the static sub-

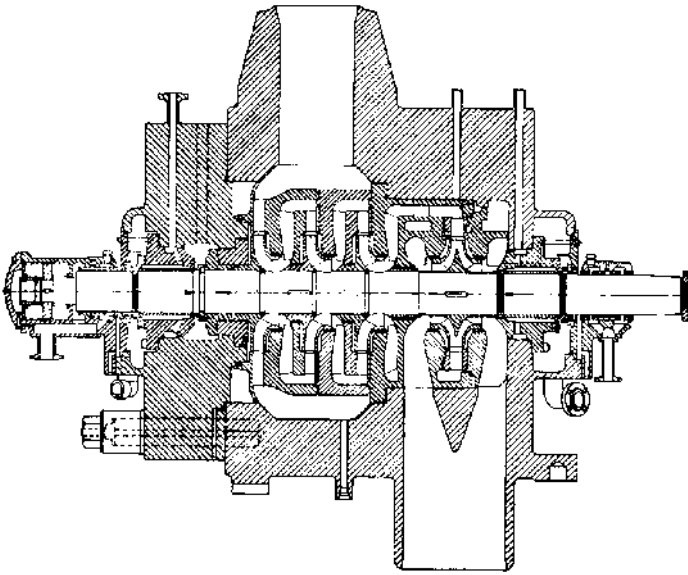


FIGURE 7 Cross-section, single 65,000 hp boiler feed pump, 1300 MW fossil power plant (Flowsolve Corporation)

mergence between the water level in the storage space and the pump centerline less the frictional losses in the intervening piping. Theoretically, the required *NPSH* is independent of operating temperature. Practically, this temperature must be taken into account when establishing the recommended submergence from the deaerator to the boiler-feed pump. A margin of safety must be added to the theoretical required *NPSH* to protect the boiler-feed pumps against the transient conditions that follow a sudden reduction in load for the main turbogenerator.

Although the previous discussion applies primarily to the majority of installations, where the boiler-feed pump takes its suction from a deaerating heater, it holds as well in the closed feed cycle (Figure 6). The discharge pressure of the condensate pump or the booster pump must be carefully established so the suction pressure of the boiler-feed pump cannot fall below the sum of the vapor pressure at pumping temperature and the required *NPSH*.

Careful attention must be given to any strainer that might be installed in the pump suction piping. The pressure drop increase across the strainer is indicative of foreign material and it reduces the net positive suction head available (*NPSHA*) to the pump. Strainers in the pump suction pipe are most often removed following plant start-up qualification testing.

**Transient Conditions Following Load Reduction** Following a sudden load reduction, the turbine governor reduces the steam flow in order to maintain the proper relation between turbine and generator power and to hold the unit at synchronous speed. The consequence of this reduction is a proportionate pressure reduction at all successive turbine stages, including the bleed stage that supplies steam to the deaerator. The check valve in the extraction line closes and isolates the heater from the turbine. As hot feedwater continues to be withdrawn from the heater and cold condensate to be admitted to the heater, the pressure in the direct-contact heater starts to drop rapidly. The check valve reopens when the heater pressure has been reduced to the prevailing extraction pressure and stable conditions are reestablished.

It should be noted that, even though the feedwater system in a drum boiler may be provided with a three-element feedwater regulator, the feedwater flow will not instantaneously follow the steam flow as soon as the steam demand is reduced by a reduction in unit load. Because of the time lag between the reduction in steam demand and that of the fuel-burning rate and because of the heat retention in the steam generator, there is a momentary rise in the boiler pressure, with the resultant collapse of some of the steam and water bubbles in the boiler drum. This lowers the apparent boiler drum level, causing the level control to override to some degree the impulse from the change in steam flow. Therefore, there will generally be a definite lack of correlation between feedwater and steam flow following a sudden drop in load. The exact degree of the difference between these two flows will depend upon the particular type and setting of the feedwater controls. In some extreme cases, the feedwater flow after a sudden drop in load can actually exceed the feedwater flow at maximum design conditions. Thus, it is a safer practice to assume that the feedwater flow will not be reduced and to assume that the *NPSH* required will in turn correspond to at least its value under flow conditions preceding the drop in load.

In the interval, however, the pressure at the boiler-feed pump suction is reduced correspondingly. Unfortunately, until the suction piping has been completely voided of the feedwater it contained prior to the load reduction, its temperature and vapor pressure will not be reduced. As a consequence, the available *NPSH* will diminish and may become insufficient to provide adequate pump operation. In such a case, the pump will flash and serious damage may be incurred.

The factor that establishes the adequacy of an installation from the point of view of suction conditions after a load drop is the ratio between the direct-contact heater storage capacity and the suction piping volume. Based on a number of simplifying assumptions, a formula has been developed for the minimum value of this ratio:

$$\text{Minimum } \frac{Q_h}{Q_s} = \frac{h_{x0} - h_{c2}}{K_h H_x} \quad (1)$$

where  $Q_h$  = volume of feedwater in heater storage, gal ( $\text{m}^3$ )

$Q_s$  = volume of feedwater in suction piping, gal ( $\text{m}^3$ )

$h_{x0}$  = enthalpy of feedwater under initial conditions, Btu/lb (J/kg)

$h_{c2}$  = enthalpy of condensate to heater under final conditions, Btu/lb (J/kg)

$K_h$  = change in enthalpy with pressure at steam conditions prior to load reduction, Btu/lb • ft absolute pressure (J/kg • m) (Figure 8)

$H_x$  = available excess *NPSH* = *NPSH* available – *NPSH* required, ft (m)

This relationship is somewhat conservative and does not take into account the residence time of the condensate in the piping and the closed heaters between the condenser hot well and the direct-contact heater. A slightly less conservative formula that takes some account of this residence time is

$$\text{Minimum } \frac{Q_h}{Q_s} = \frac{h_{x0} - [(h_{c0} + h_{c2})/2]}{K_h H_x} \quad (2)$$

where  $h_{c0}$  = enthalpy of condensate to heater under initial conditions, Btu/lb (J/kg)

For example, let

Initial heater pressure = 153 lb/in<sup>2</sup> (10.5 bar)

Initial feedwater temperature = 360°F (182°C)

Initial feedwater enthalpy = 331.4 Btu/lb (770.8 kJ/kg)

Final condensate enthalpy = 82.95 Btu/lb (192.9 kJ/kg)

$K_h$  (from Figure 8) = 0.22 Btu/lb/ft (1679 J/kg/m)

$H_x$  (available excess *NPSH*) = 15 ft (4.57 m)

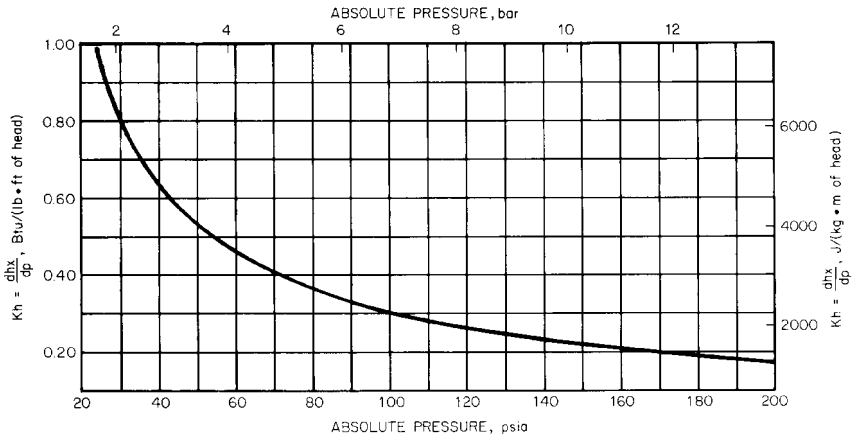


FIGURE 8 Enthalpy change with change of vapor pressure, for water

Then

$$\text{in USCS units} \quad \text{Minimum } \frac{Q_h}{Q_s} = \frac{331.4 - 82.95}{0.22 \times 15} = 75.3$$

$$\text{in SI units} \quad \text{Minimum } \frac{Q_h}{Q_s} = \frac{770,800 - 192,900}{1679 \times 4.57} = 75.3$$

This means that for safe operation after a sudden load drop in this particular case, the heater storage volume must be at least 75.3 times the volume of the suction piping.

More complex and more rigorous calculations of the minimum ratio of heater storage volume to suction piping volume are provided in Reference 1.

Even where analysis indicates that the boiler-feed pumps are assured of their required *NPSH* during a reduction in turbine load, there is no guarantee that their operation will not be interrupted by flashing at some point in the suction piping. The criterion in determining the probability of flashing in the suction piping is to consider that the water that left the heater outlet at a saturated condition must pick up static pressure, by means of the vertical drop, at a rate at least equal to the pressure decay rate of the heater, or it will flash.

The most adverse conditions are those introduced by locating a horizontal run of piping too close to the heater outlet. A typical case is illustrated in Figure 9. (Because this example is used merely to illustrate the unfavorable effect of such a piping layout, the unit system used is immaterial and the example has been expressed in USCS units.) In the comparison of the two installations, we will stipulate that the total length and the sizes of the piping are the same for both arrangements and that the volumes of the suction piping between the heater outlet and points *C* and *E* of the two arrangements are the same. To simplify the comparison, the vertical distances between *A* and *B*, *B* and *D*, and *A* and *E* have been expressed in pounds per square inch instead of feet.

If a time interval *x* is selected such that water having left the heater outlet at the start of the transient conditions will have reached points *C* and *E*, respectively, at the end of the time interval, it becomes apparent that in the case illustrated on the left side of Figure 9, the pressure gain at point *C* is only 3 lb/in<sup>2</sup> by virtue of the vertical drop. Thus, *x* seconds after a pressure drop in the direct-contact heater from 52 to 48 lb/in<sup>2</sup> gage, the pressure at point *C* will be 51 lb/in<sup>2</sup>, which is below the vapor pressure at the new temperature (296°F), and so flashing will occur. On the other hand, in the case of a straight vertical drop (right side of Figure 9), after the same time interval *x* the pressure will be 60 lb/in<sup>2</sup>, which exceeds the vapor pressure, and so no flashing will occur. Formulas 1 and 2 can be used to

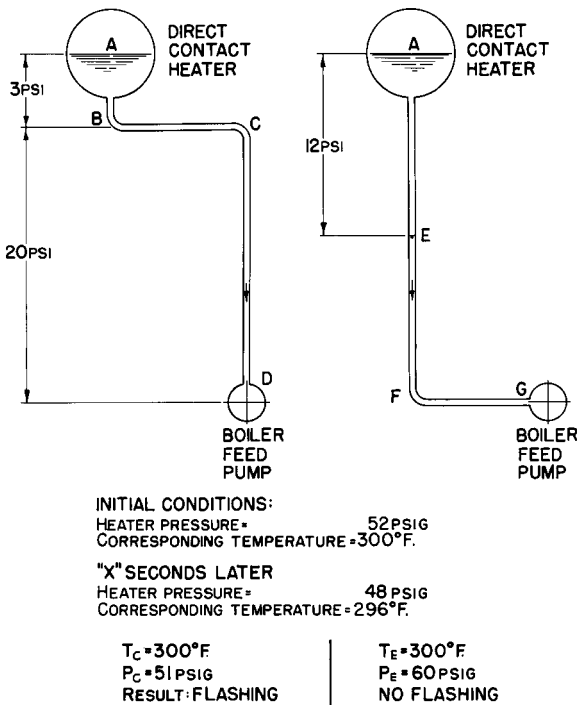


FIGURE 9 Comparison of suction piping arrangements

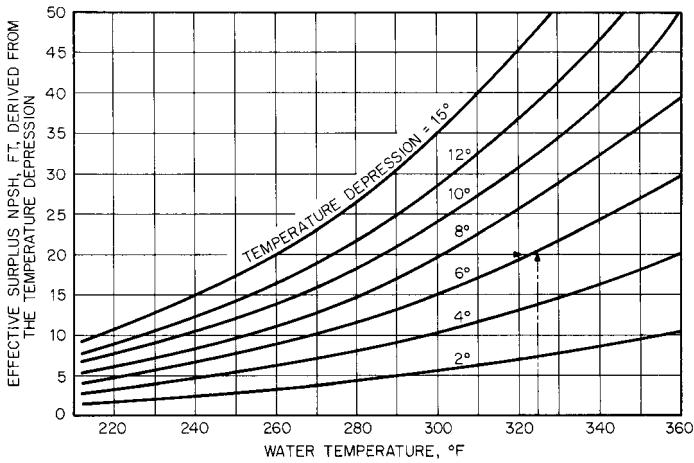
determine the adequacy of the piping layout by selecting the critical point in the piping (in this case, point  $C$ ) and substituting in the formulas so  $Q_s$  = volume in suction piping to point  $C$  and  $H_x$  = static head to point  $C$  less frictional losses to point  $C$ .

In the event that circumstances do not permit the provision of sufficient  $NPSH$  margin to provide adequate protection to the boiler-feed pumps during a sudden turbine load reduction, two alternate means are available to compensate for these circumstances:

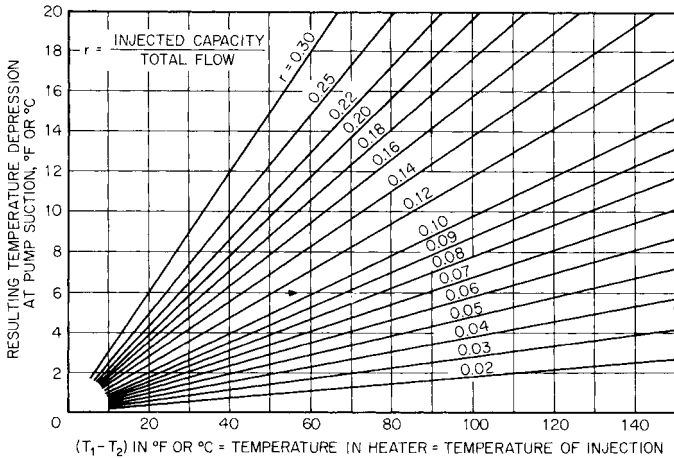
1. A small amount of steam from the boiler can be admitted to the direct-contact heater through a pressure-reducing valve, to reduce the rate of pressure decay in the heater.
2. A small amount of cold condensate from the discharge of the condensate pumps can be made to bypass all or some of the closed heaters and be injected at the boiler-feed pump suction to subcool the feedwater, thus providing additional  $NPSH$  margin during load reduction.

Figure 10 illustrates the effect of subcooling (or temperature depression) on the available  $NPSH$  at various initial feedwater temperatures. Figure 11 shows, for varying ratios of injection flows, the temperature depression resulting from cold water injection plotted against the difference in temperature between the feedwater and the injection stream. For instance, if it were desired to provide 20 ft (6.1 m) additional  $NPSH$  to a boiler-feed pump that handles 325°F (163°C) water, the required temperature depression is 6°F (3.3°C). If the injection water temperature is 190°F (87.8°C), the difference between feedwater and injection water temperature is 135°F (75.2°C). From Figure 11, we can see that the injection flow must be 4.5% of the total feedwater flow.

An analysis of the relative merits of the two methods of protecting boiler-feed pumps against the unfavorable effects of transient conditions is presented in Reference 2. Either



**FIGURE 10** Effect of subcooling on available NPSH at various initial water temperatures. [ $^{\circ}\text{C} = (^{\circ}\text{F} [\text{min}] 32)/5/9$ ; 1 ft = 0.3048 m]



**FIGURE 11** Required amount of cold water injection for a given temperature depression

corrective action can be initiated automatically. This involves constant monitoring of the suction pressure and of the vapor pressure of the feedwater at the pump suction. The difference between the two is then constantly compared with a pre-established minimum *NPSH*. Any transient condition that causes the available *NPSH* to fall below this desired minimum initiates corrective action, be it admission of cold condensate at the pump suction or admission of auxiliary steam to the direct-contact heater.

Another transient condition that will create a two-phase (steam-water mixture) flow at the pump suction—and in the pump—may occur during a “hot restart.” When the plant experiences a trip, the pump is secured and the pressure in the deaerator drops. The temperature in the deaerator consequently drops within a relatively short period of time. The feedwater temperature has dropped from perhaps 350°F (175°C) to 250°F

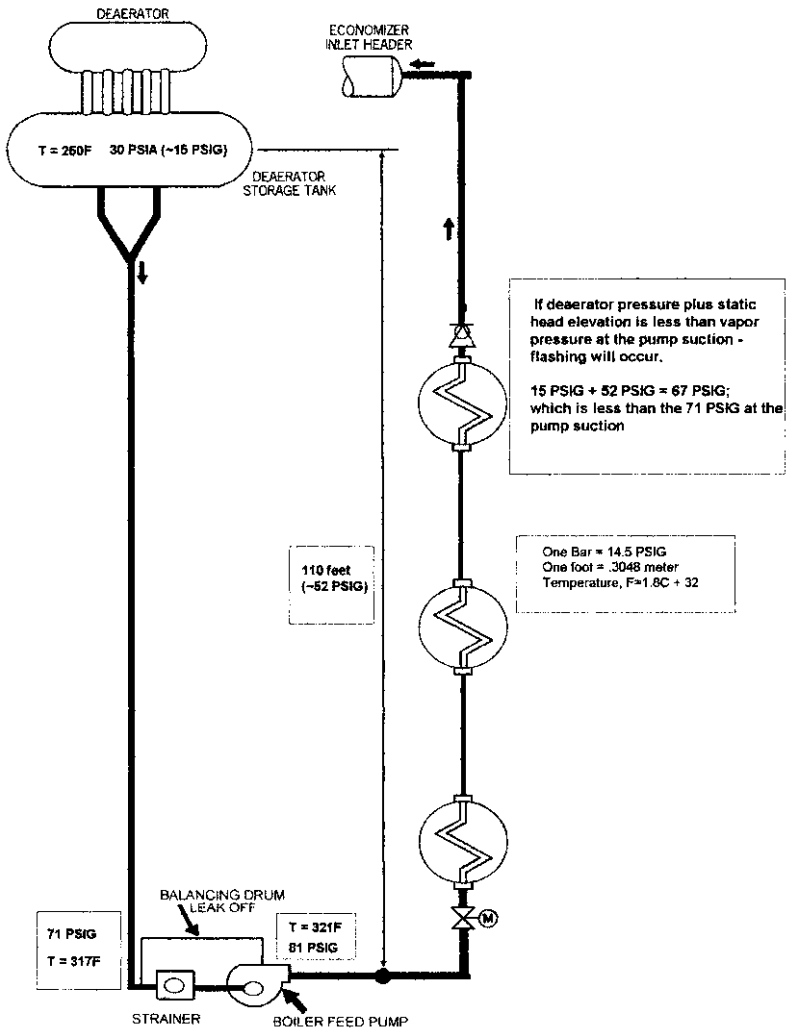


FIGURE 12 Feedwater system daigram, "hot restart" transient

(120°C). The pump and suction piping near the pump remain at a higher temperature due to the mass of the metal (Figure 12). In a short time, the idle pump is switched on, and a two-phase flow condition occurs at the pump suction. Potential failure mode effects include suction cavitation, rotor upset and contact with stationary wear rings, and water hammer.

### BOOSTER PUMPS

The increasing sizes of modern boiler-feed pumps coupled with the practice of operating these pumps at speeds considerably higher than 3600 rpm have led to *NPSH* require-



ments as high as 150 to 250 ft (46 to 76 m). In most cases, it is not practical to install the direct-contact heaters from which the feed pumps take their suction high enough to meet such requirements. In such cases, it has become the practice to use boiler-feed booster pumps operating at lower speeds, such as 1750 rpm, to provide a greater available *NPSH* to the boiler-feed pumps than can be made available from strictly static elevation differences. Such booster pumps are generally of the single-stage, double-suction design.

**Discharge Pressure and Total Head** The discharge pressure is the sum of the maximum boiler drum pressure and the frictional and control losses between the boiler-feed pump and the boiler drum inlet. The required discharge pressure will generally vary from 115 to 125% of the boiler drum pressure. The net pressure to be generated by the boiler-feed pump is the difference between the required discharge pressure and the available suction pressure. This must be converted to a total head, using the formula

$$\text{in USCS units} \quad \text{Total head, ft} = \frac{\text{net pressure, lb/in}^2 \times 2.31}{\text{sp. gr.}}$$

$$\text{in SI units} \quad \text{Total head, m} = \frac{\text{net pressure, bar} \times 10.2}{\text{sp. gr.}}$$

**Slope of the Head-Capacity Curve** In the range of specific speeds normally encountered in multistage centrifugal boiler-feed pumps, the rise of head from the point of best efficiency to shutoff will vary from 10 to 25%. Furthermore, the shape of the head-capacity curve for these pumps is such that the drop in head is very slow at low capacities and accelerates as the capacity is increased.

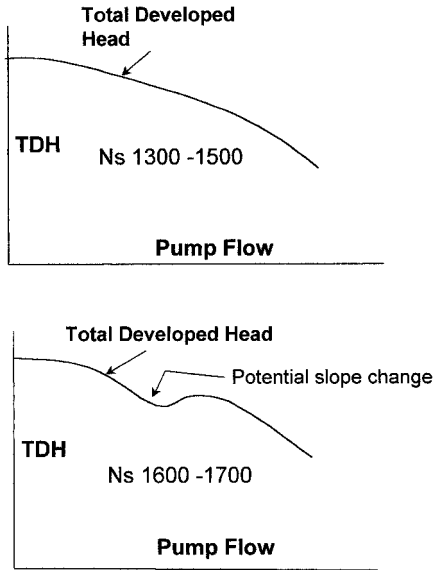
If the pump is operated at constant speed, the difference in pressure between the pump head-capacity curve and the system-head curve must be throttled by the feedwater regulator. Thus the higher the rise of head toward shutoff, the more pressure must be throttled off and, theoretically, wasted. Also, the higher the rise, the greater the pressure to which the discharge piping and the closed heaters will be subjected. However, it is not advisable to select too low a rise to shutoff because too flat a curve is not conducive to stable control; a small change in pressure corresponds to a relatively great change in capacity, and a design that gives a very low rise to shutoff may result in an unstable head-capacity curve, difficult to use for parallel operation. When several boiler-feed pumps are to be operated in parallel, they must have stable curves and equal shutoff heads. Otherwise, the total flow will be divided unevenly and one of the pumps may actually be backed off the line after a change in required capacity occurs at light flows.

As feedwater flows increased in the 650 to 1300 MW fossil central stations and new construction of nuclear power plants occurred, the pump specific speed ( $N_s$ ) increased. [Refer to Section 2.1.] Specific speeds of 1200 to 1500 for typical feedwater pumps increased to 1600 to 2100. The performance curve characteristic for 1200 to 1500  $N_s$  pumps typically has a constantly rising curve slope. The performance characteristic for a pump with a  $N_s$  of 1600 to 2100 often will exhibit a depression (change to a very low, or negative slope) at reduced flow rates (Figure 13).

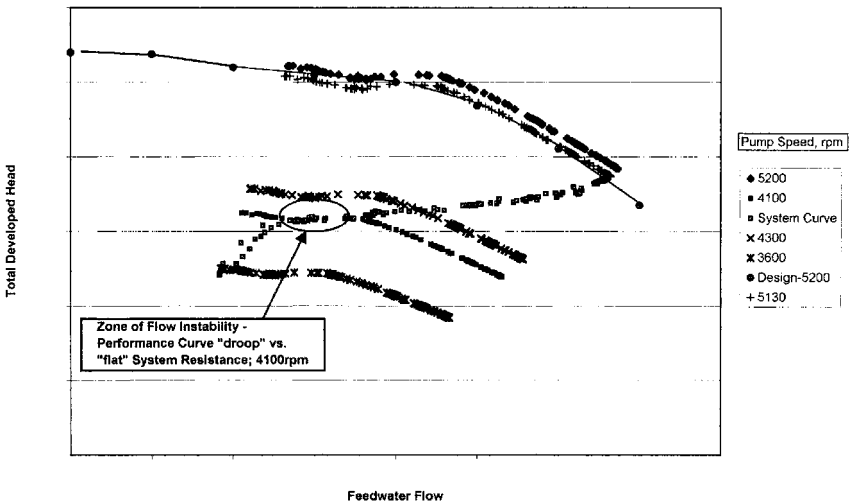
**NOTE:** If a high specific-speed pump is operated at low loads and reduced flow rates, there is risk of entering a performance curve region that will result in flow instability and surge. High subsynchronous vibrations and possible vane pass energy is excited (Figure 14,  $N_s = 1700$ ). This operating condition is potentially damaging to the boiler feed pump. Attention to impeller and diffuser areas is critical to prevent this condition from occurring. Underfilled impellers (see Subsection 2.3.1) and high area ratios between the impeller and the diffuser or volute will tend to flatten the performance curve and can result in a depressing effect on the slope of the performance curve.

**Driver Power** A boiler-feed pump will generally not operate at any capacity beyond the design condition. In other words, a boiler-feed pump has a very definite maximum capacity because it operates on a system-head curve made up of the boiler drum pressure plus

### Performance Curve Characteristic



**FIGURE 13** Pump performance curve characteristic—specific speed versus stability  
 (Universal specific speed  $\Omega_s = N_s/2733 \cdot N_g$  (in rpm, m<sup>3</sup>/s, m) =  $N_s/51.65$ )



**FIGURE 14** Performance characteristic—28,000 hp boiler feed pump ( $N_s = 1700$ )  
 (Universal specific speed  $\Omega_s = N_s/2733 \cdot N_g$  (in rpm, m<sup>3</sup>/s, m) =  $N_s/51.65$ )

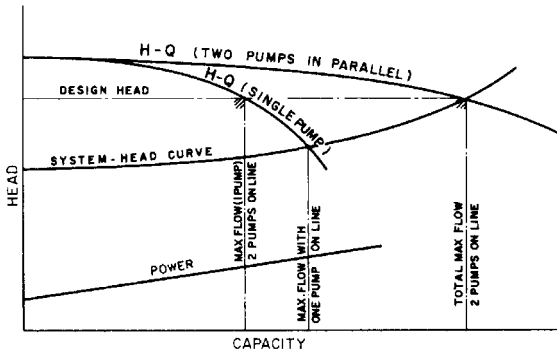


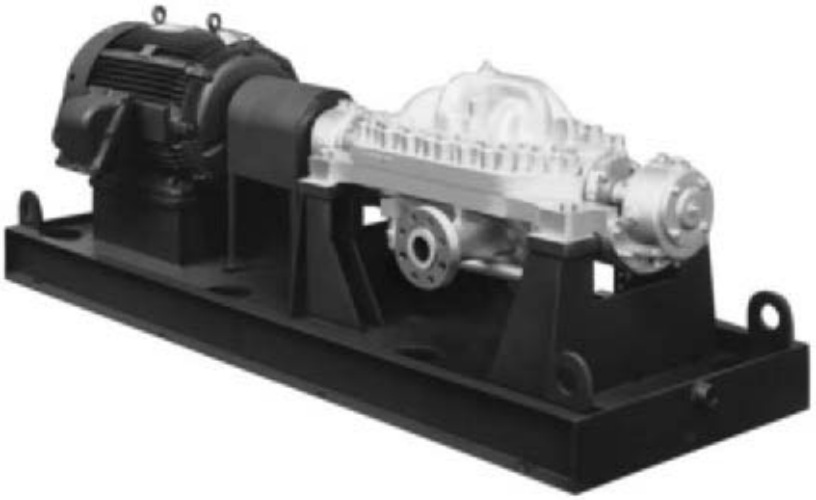
FIGURE 15 Method of determining maximum pump power for two boiler-feed pumps operating in parallel

the frictional losses in the discharge. If, as it should be, the design capacity of the pump is chosen as the maximum capacity that can be expected under emergency conditions, there can be no further increase under any operating conditions since the pressure requirement corresponding to an increased capacity would exceed the design pressure of the pump. Even when the design pressure includes a safety margin, the boiler demand does not exceed the design capacity, and the feedwater regulator will impart additional artificial frictional losses to increase the required pressure up to the pressure available at the pump.

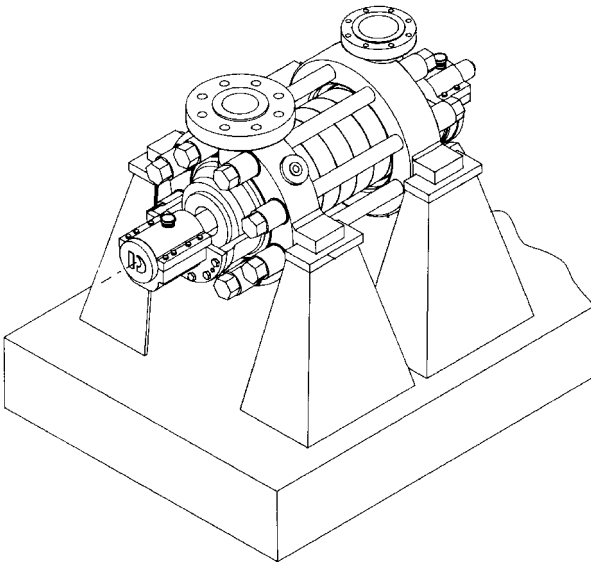
When two pumps are operated in parallel, feeding a single boiler, the situation is somewhat different. If one of the pumps is taken off the line at part load, the remaining pump could easily operate at capacities in excess of its design because its head-capacity curve would intersect the system-head curve at a head lower than the design head (Figure 15). In such a case, it is necessary to determine the pump capacity at the intersection point; the power corresponding to this capacity will be the maximum expected. It is not always necessary to select a driver that will not be overloaded at any point on the boiler-feed pump operating curve. Although electric motors used on boiler-feed service generally have an overload capacity of 15%, it is usually the practice to reserve this overload capacity as a safety margin and to select a motor that will not be overloaded at the design capacity. Exceptions occur in the case of very large motors. For instance, if the pump brake horsepower is 3100, it is logical to apply a 3000-hp motor, which will be overloaded by about 3% rather than a considerably more expensive 3500-hp motor. Because steam turbines are not built in definite standard sizes but can be designed for any intermediate rating, they are generally selected with about 5% excess power over the maximum expected pump power.

**General Structural Features** Boiler feed pumps designed for pressures of less than 2500 lb/in<sup>2</sup> (172 bar) are generally of the axially split casing type (Figure 16). Some special axially split designs approach 4000 lb/in<sup>2</sup> (275 bar) maximum working pressure. Radially split segmental ring-type pumps (Figure 17) are utilized for pressures up to approximately 3500 lb/in<sup>2</sup> (240 bar). Radially split, double-case barrel pumps (Figure 18) are in feedwater services up to 6500 lb/in<sup>2</sup> (250 bar). The selection of materials for boiler feed pump casings and internal parts is discussed in Section 5.1.

**Nuclear Power Plants** In oversimplified form, the nuclear energy steam power plant differs from the conventional power plant only in that it uses a different fuel. Thus what is called the secondary cycle (consisting of turbogenerator, condenser and auxiliaries, and boiler-feed pumps) is not very different from its counterpart in the conventional steam power plant. The main differences are a desire for even greater equipment reliability and a preference for an absence or minimum of leakage to avoid any possibility of contamination with radioactive material. One other difference distinguishes most nuclear power

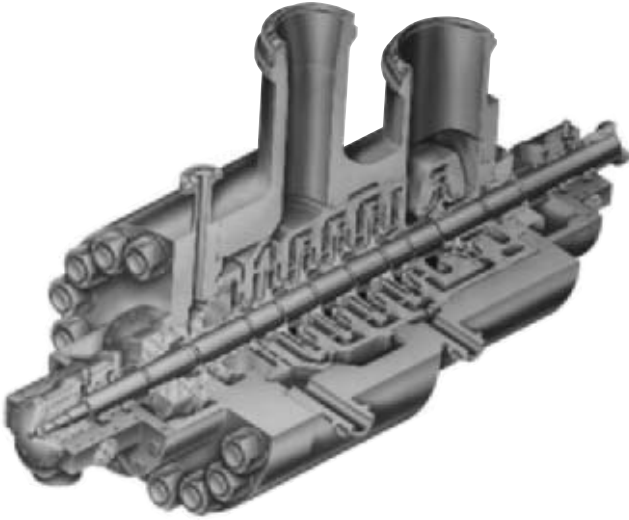


**FIGURE 16** Axially split case multistage boiler feed pump, up to 3500 lb/in<sup>2</sup> (241 bar). (Flowsolve Corporation)

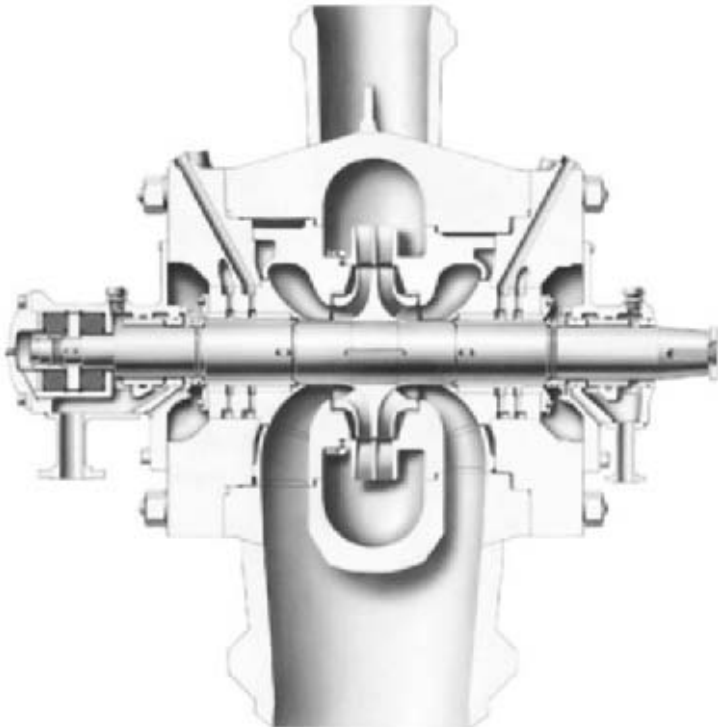


**FIGURE 17** Radially split, segmental ring boiler feed pump (Flowsolve Corporation)

plants today from their fossil fuel counterparts: their operating steam pressures and temperatures are much lower. Consequently, in most cases, reactor feed pumps are single-stage pumps; a typical section is shown in Figure 19. The lower operating conditions result in higher heat rates, and the flows—both of the feedwater and of the condenser circulation—are about one-third higher than for fossil fuel power plants of equal megawatt rating.



**FIGURE 18** Radially split, double-case, barrel boiler feed pump (Flowsolve Corporation)



**FIGURE 19** Single stage double suction reactor feed pump, 12,000 horsepower (8950 KW) (Flowsolve Corporation)

More detailed information on other nuclear power plant pumping services is given in Subsection 9.14.1.

**High-Speed, High-Pressure Boiler Feed Pumps** As steam pressures rose to 3000—and even to 4500 lb/in<sup>2</sup> (200 to 310 bar)—the total head that was required to be developed by the pump rose from around 4000 ft (1220 m) to as high as 7000 and 12,000 ft (2140 and 3660 m). The only means available of achieving these higher heads at 3600 rpm (2-pole motor speed at 60 Hz) was to increase impeller diameter and the number of stages. The pumps had to have longer and longer shafts to accommodate the larger number of stages. This threatened to interfere with the long uninterrupted life between overhauls to which steam power plant operators were beginning to become accustomed. The logical solution was to reduce the shaft span by reducing the number of stages.

In the 1970s, stage pressures rose from around 800 ft/stage to 3000 ft/stage and higher. Several single, 65,000 horsepower (48,500 kW) boiler feed pumps were constructed to support 1300 MW fossil plants (Figure 20). The higher head requirements were achieved by increasing the speed of rotation instead of increasing impeller diameter or stage number. As a result, boiler feed pumps in large central stations today generally operate at speeds from 5000 to 9000 rpm.

**Boiler-Feed Pump Drives** The majority of boiler-feed pumps in small and medium-size steam plants are driven by electric motors. It was the practice to install steam-turbine driven standby pumps as a protection against the interruption of electric power, but this practice has disappeared in central steam stations.

Central stations have trended away from electric motor drives, including those equipped with hydraulic couplings, fluid, and variable frequency drives, to steam turbines for units in excess of 200 MW because

1. The use of an independent steam turbine increases plant capability by eliminating the auxiliary power required for boiler feeding.
2. Proper utilization of the exhaust steam in the feedwater heaters can improve cycle efficiency.
3. In many cases, the elimination of the boiler-feed pump motors may permit a reduction in the station auxiliary voltage.
4. Driver speed can be matched ideally to the pump optimum speed.
5. A steam turbine provides variable-speed operation and better flow compliance to varying plant load and flow demands without an additional component, such as a hydraulic coupling.

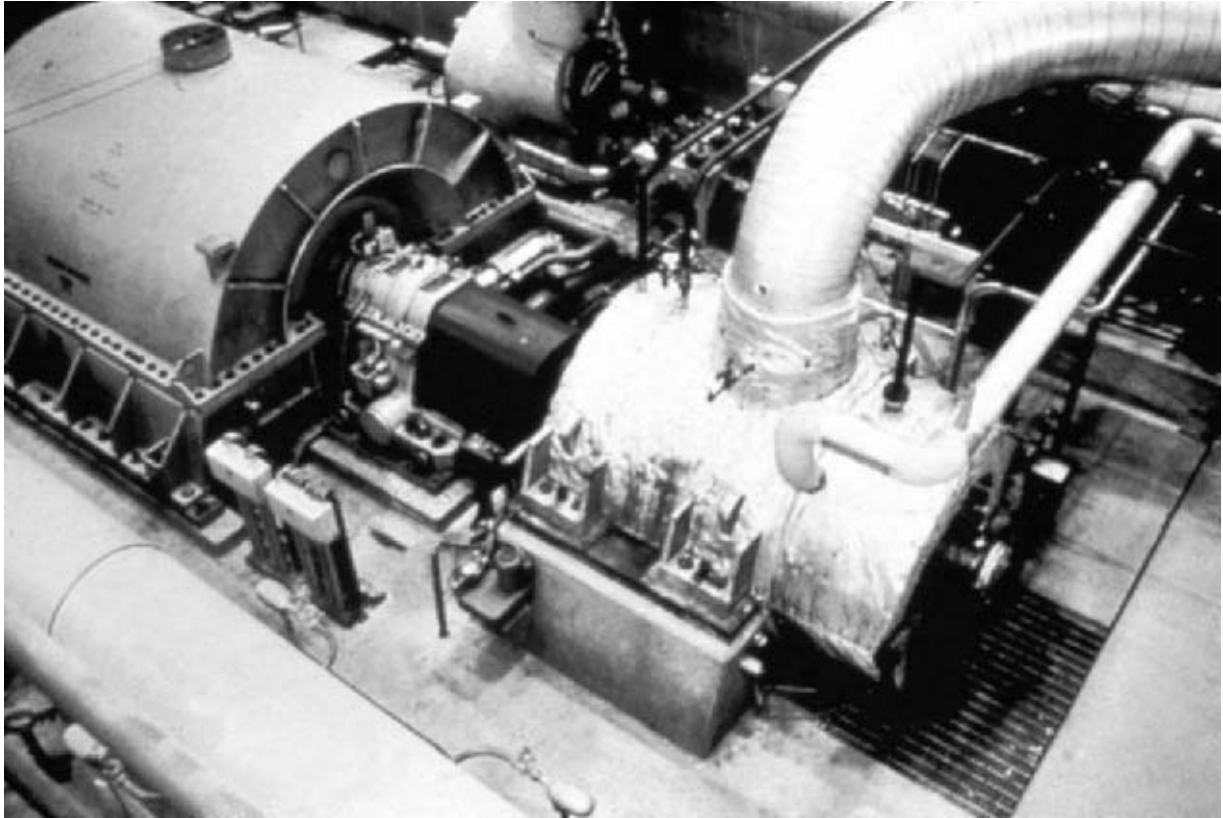
Many combined cycle plants are constructed utilizing motor-driven boiler feed pumps to facilitate flexibility in start-up and varying load demands.

Application of variable frequency drive (VFD) motors continues as equipment costs drop. The VFD technology provides variable motor speeds by controlling the frequency input.

**Operation of Boiler-Feed Pumps at Reduced Flows** Operation of centrifugal pumps at shutoff or even at certain reduced flows can lead to very undesirable results. This subject is covered in detail in Subsections 2.3.1 to 2.3.4, Section 8.1, and Chapter 12, where methods for calculating minimum permissible flows and means for providing the necessary protection against operation below these flows are discussed.

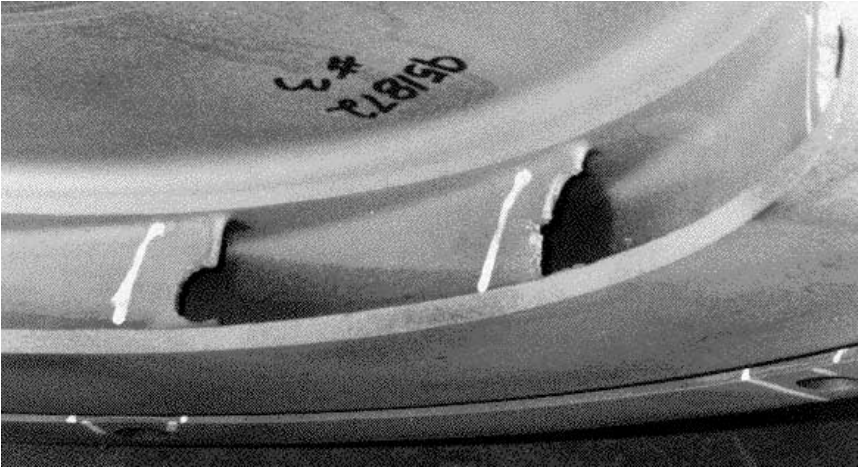
Recent experiences have clearly defined the need to understand hydraulic instability, cavitation, and separation as they relate to off-design flow operation.

As deregulation and economic constraints dictate plant load cycling to match electricity demands and operating costs, the large central station boiler feed pumps experience significantly low operating flow. The low flow operation, high impeller suction specific speed, and high inlet tip speeds result in mismatched flow angles, backflow recirculation, and severe suction impeller inlet cavitation damage. This low flow hydraulic instability will also result in damage to pump volute cutwaters and diffuser

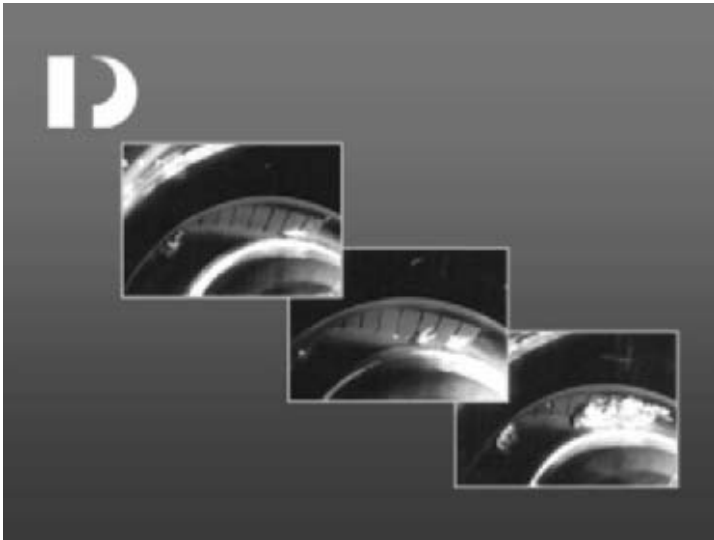


**FIGURE 20** Installation of a single 65,000 horsepower (48,500 kW) boiler pump feed (Flowserve Corporation)





**FIGURE 21** Diffuser inlet vane erosion damage (Flowserve Corporation)

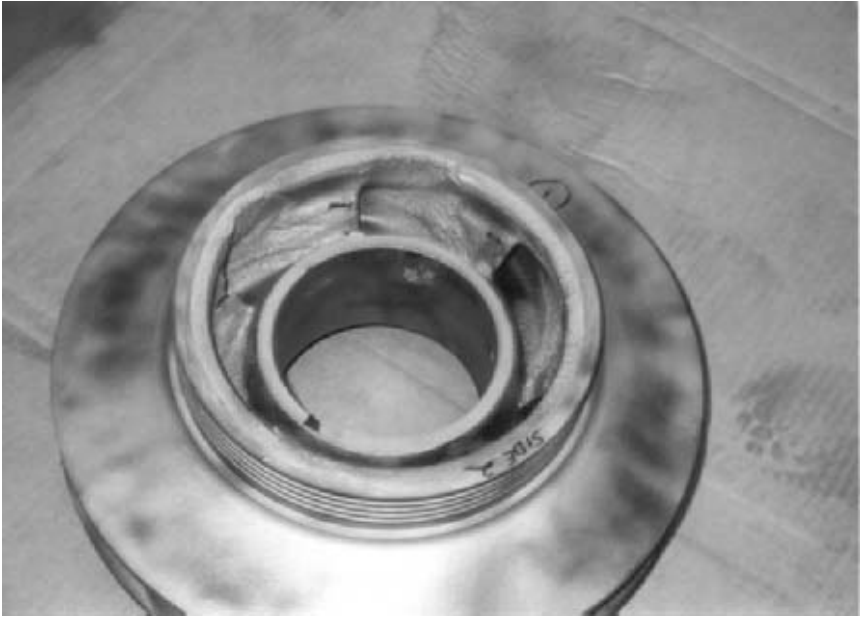


**FIGURE 22** Unsteady vapor cavity behavior, feed pump at low flow (Flowserve Corporation)

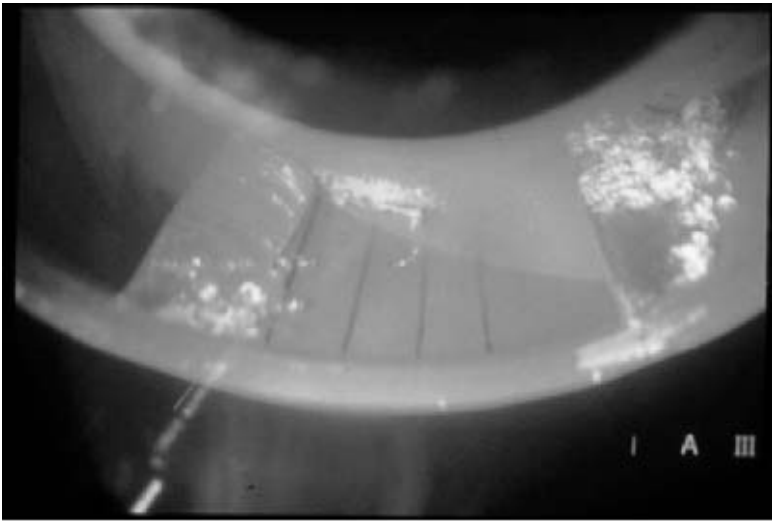
vanes (Figure 21). Suction impellers where the suction specific speed exceeds 10,000 and eyebore inlet tip speeds exceed 200 ft/sec. are highly susceptible to this low flow instability and component damage. The series of photos in Figure 22 show a condition typical for many high-energy pumps operating at flows below design levels. They demonstrate how serious low-flow instability can be when it is coupled with two-phase flow activity.

The severity of cavitation erosion is highly dependent on the inlet tip speed of the suction stage impeller, the *NPSHA*, and the thermodynamic properties of the fluid being pumped. The erosion seen in Figure 23 was caused by the collapse of discrete cavitation





**FIGURE 23** Impeller inlet vane cavitation erosion damage (Flowsolve Corporation)



**FIGURE 24** Cavitation vapor bubbles on suction surface of the impeller inlet vane (Flowsolve Corporation)

vapor bubbles. Cavitation forms around an impeller blade because of local static pressure falling below the vapor pressure of the liquid being pumped. The vapor cavity shown in Figure 24 is an example of this phenomenon.

With decreasing flow rates (due to operating at off-design conditions), the fluid approaches the impeller blade with larger and larger angles of incidence altering the velocity and pressure fields inside the impeller.

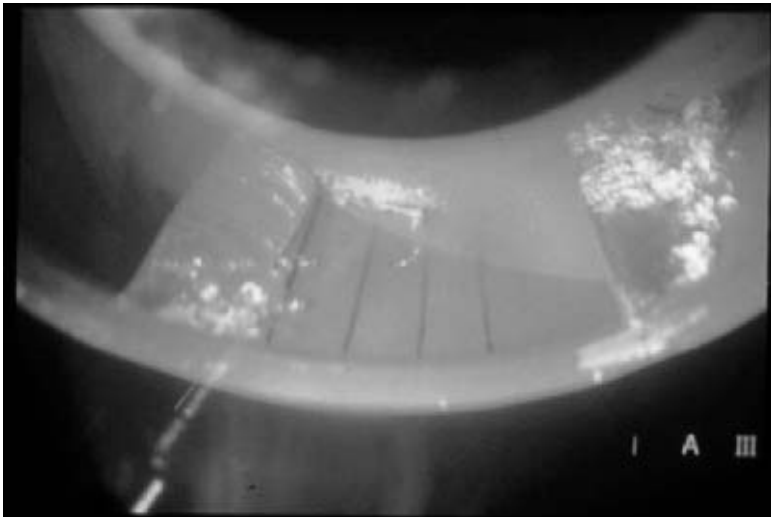
Pumps that are cycled between minimum-flow and flows in excess of the best efficiency point (BEP) create conditions at the impeller in excess of what “fixed geometry” machines can effectively tolerate. Impeller geometry has been shown to influence the degree and severity of cavitation problems experienced with high-energy pumps.

Through the 1980s, attempts were made to pursue “non-traditional” designs of impeller blading. These efforts took the form of profiling the inlet blade in a way that rapidly increased and then decreased the blade thickness.

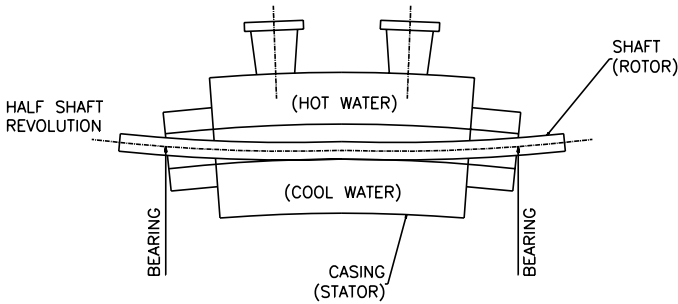
A new impeller blade design approach, referred to as a “biased-wedge” design, has been found to provide a manufacturable configuration that enables cavitation bubble-free operation over a wide fluid flow range. This design approach is a result of extensive flow visualization test work and computational fluid flow analysis of many impeller geometries. It successfully advances the performance of high-energy pump suction stages to levels not achievable with conventional designs. Dramatic reduction in cavitation activity on the impeller was recorded as seen in the photo (Figure 25) of the suction surface of the final impeller taken at identical positions in the suction inlet and at the same operating conditions (baseload and minimum flow) as Figure 24. The inlet vane air foil shape has proven successful in facilitating feed pump flow rangeability.

**Fundamentals for Successful Operating Life—Efficiency/Reliability** Best practices for extended successful operating life of pumps are outlined in Chapter 12. Essential fundamentals to emphasize for boiler feed pumps are proper pump warm-up, standby warming, and shaft (fixed bushing) seal drain temperature control. These characteristics have become more critical as central station plants are cycled and large feed pumps are operated with varying loads and in standby modes. Current designs of multistage pumps (Figure 17) installed in combined cycle plants are less sensitive to thermal transients and wide swings in load (pump flow).

Pre-warming of the pump and maintaining warm-up flow to an idle pump to assure dimensional thermal uniformity is essential to maintenance of internal clearances, pump efficiency, and long life. This process is critical for multistage pumps to minimize thermal



**FIGURE 25** Operation at same flow as Figure 24, improved inlet vane shape—dramatic vapor bubble reduction (Flowserve Corporation)



**FIGURE 26** Thermal distortion of feed pump casing and shaft, due to improper warm-up and thermal stratification

stratification within the pump. The distortion, including shaft bowing (Figure 26), will cause the following potential failure modes:

1. Flashing
2. Internal rubbing
3. Increased wear ring clearances
4. Pump seizure
5. Worn seal bushing clearance and excessive leakage
6. Loss of pump performance and efficiency
7. High pump vibration
8. Worn bearings/bearing clearances

Installation features and operating practices that extend pump life, efficiency, and reliability are

1. Proper pump insulation (Figure 27) at the casing and discharge head
2. Warm-up orifice, piped around the discharge check valve. Preference is to inject warm-up flow to the bottom of the pump casing to minimize short-circuiting of the hot feedwater and potential thermal stratification within the casing.
3. Maintaining shaft seal leakage drain temperature (Figure 28) between 150 and 170°F (65 and 77°C); utilize an electro-pneumatic temperature control system.
4. Installation of thermocouples or other temperature-detecting instruments (Figure 29) in the pump casing and discharge head to confirm temperature differences within 50°F (28°C) across the pump and relative to the feedwater temperature.
5. Assurance of proper functioning of the pump casing “pin” and “key” block to allow uniform thermal growth. Confirm that the hold-down bolts for the outboard casing feet are not over-torqued, preventing uniform axial thermal growth as the pump is heated.
6. Assurance of proper location and functioning of critical pipe hangers to minimize pipe strain on the pump suction and discharge nozzles.

## CONDENSATE PUMPS

Condensate pumps take their suction from the condenser hot well and discharge either to the deaerating heater in open feedwater systems (refer to Figure 3) or to the suction of the

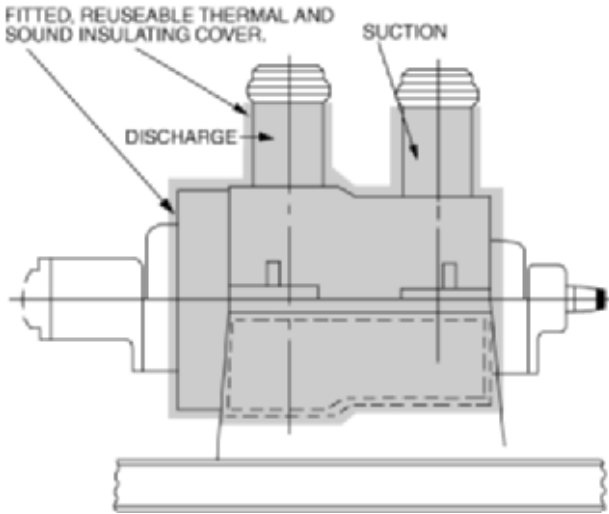


FIGURE 27 Recommended thermal insulation of a boiler feed pump (Flowsolve Corporation)

boiler-feed pumps in closed systems (refer to Figure 6). These pumps, therefore, operate with a very low pressure at their suction. The available *NPSH* is obtained by the submergence between the water level in the condenser hot well and the centerline of the condensate pump first-stage impeller. Because it is desirable to locate the condenser hot well as low as possible and avoid the use of a condensate pump pit, the available *NPSH* is generally extremely low, on the order of 2 to 4 ft (0.6 to 1.2 m). The exception to this occurs when vertical-can condensate pumps are used because these can be installed below ground and higher values of submergence can be obtained. Frictional losses on the suction side must be kept to an absolute minimum. The piping connection from the hot well to the pump should therefore be as direct as possible and of ample size and should have a minimum of fittings.

Because of the low available *NPSH*, condensate pumps operate at relatively low speeds, ranging from 1750 rpm in the low range of capacities to 880 rpm.

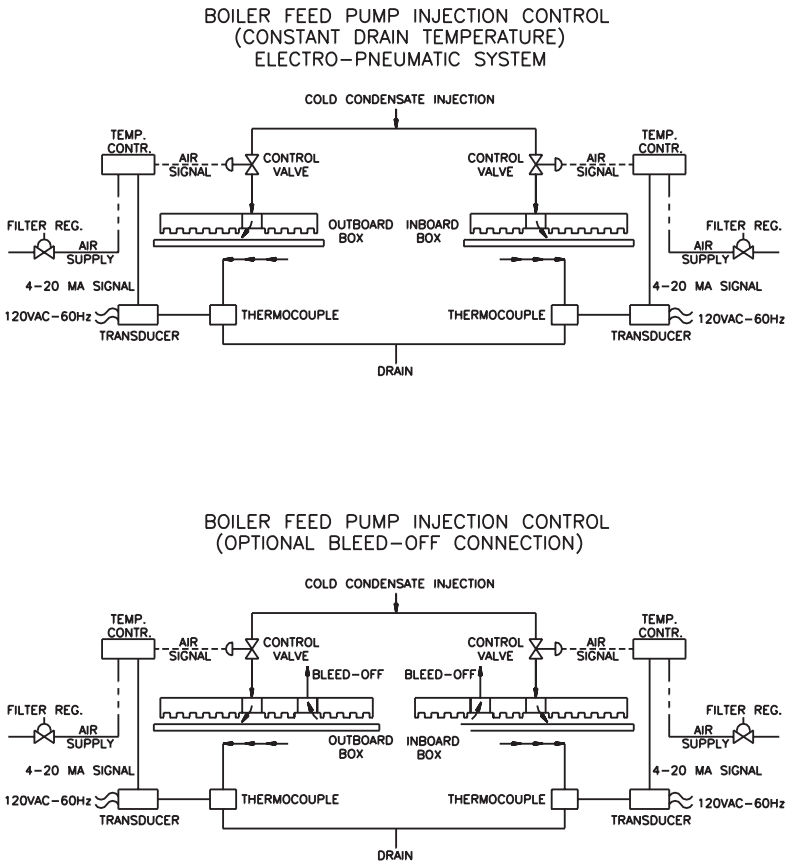
It is customary to provide a liberal excess capacity margin above the full-load steam condensing flow to take care of the heater drains that may be dumped into the condenser hot well if the heater drain pumps are taken out of service for any reason.

**Types of Condensate Pumps** Both horizontal and vertical condensate pumps are used.

Depending on the total head required, horizontal pumps may be either single-stage or multistage. Plants constructed in the 1950s and before utilized horizontally split multistage pumps mounted at the lowest plant level, near the bottom of the condenser. As required condensate flows increased in later years, the common installation incorporated vertical can-type multistage pumps (Figure 30). Combined cycle plants utilize vertical turbine-type multistage condensate pumps (Figure 31). The vertical turbine-type pump is of medium-duty construction and lower in cost than the can-type pump shown in Figure 30.

Figure 32 shows a single-suction, single-stage pump with an axially split casing used for heads up to about 100 ft (30 m). It is designed to have discharge pressure on the stuffing box. The suction opening in the lower half of the casing keeps the suction line at floor level. An oversize vent at the highest point of the suction chamber permits the escape of all entrained vapors, which will be vented back to the condenser and removed by the air-removal apparatus.

Multistage pumps are used for higher heads. A two-stage pump is shown in Figure 33, with the impellers facing in opposite directions for axial balance. By turning the impeller

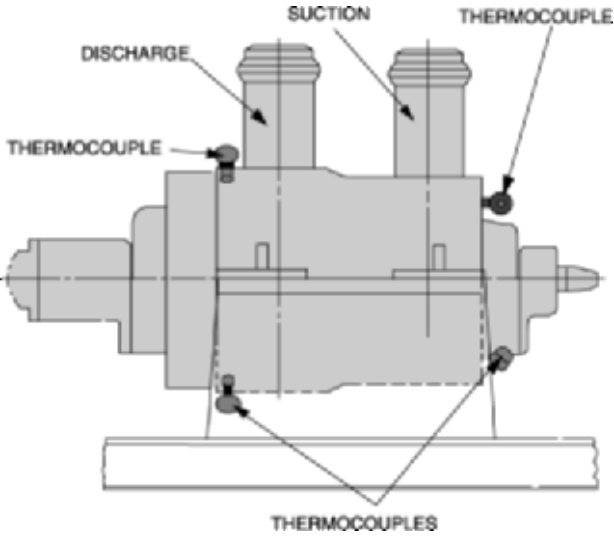


**FIGURE 28** Boiler feed pump shaft seal injection/leakage control system; electro-pneumatic control of constant drain temperature

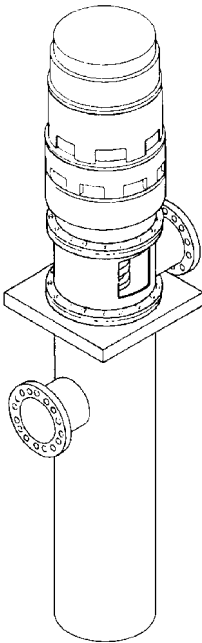
suctions toward the center, both boxes are kept under positive pressure to prevent leakage of air into the pump. For higher heads and larger capacities, a three-stage pump, as in Figure 34, may be used. The first-stage impeller is of the double-suction type and is located centrally in the pump. The remaining impellers are of the single-suction type and are also arranged so both stuffing boxes are under pressure. Two liberal vents connecting with the suction volute on each side of the first-stage double-suction impeller permit the escape of vapor.

Current plant construction utilizes vertical can-type condensate pumps (Figures 30 and 31). The chief advantage of these pumps is that ample submergence can be provided without the necessity of building a dry pit. The first stage of this pump is located at the bottom of the pumping element, and the available *NPSH* is the distance between the water level in the hot well and the centerline of the first-stage impeller.

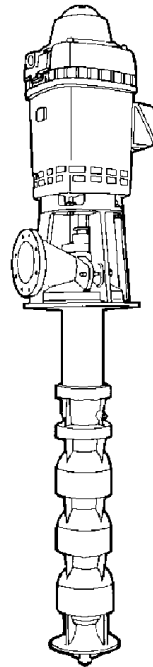
Condensate pumps are located very close to the condenser hot well, and the suction piping is generally so short that the frictional losses in this piping are not significant. However, strainers are occasionally installed in this piping, and a great deal of attention must be paid to the frictional losses through them and to their frequent cleaning. Cases have been reported on occasion where the pressure drop across these strainers was sufficient to cause flashing at the suction nozzle of the condensate pumps.



**FIGURE 29** Feed pump casing and discharge head thermocouple installation, to monitor and control uniform temperature distribution (Flowserve Corporation)



**FIGURE 30** Vertical condensate or heater drain pump (Flowserve Corporation)



**FIGURE 31** Vertical turbine condensate pump (Flowserve Corporation)

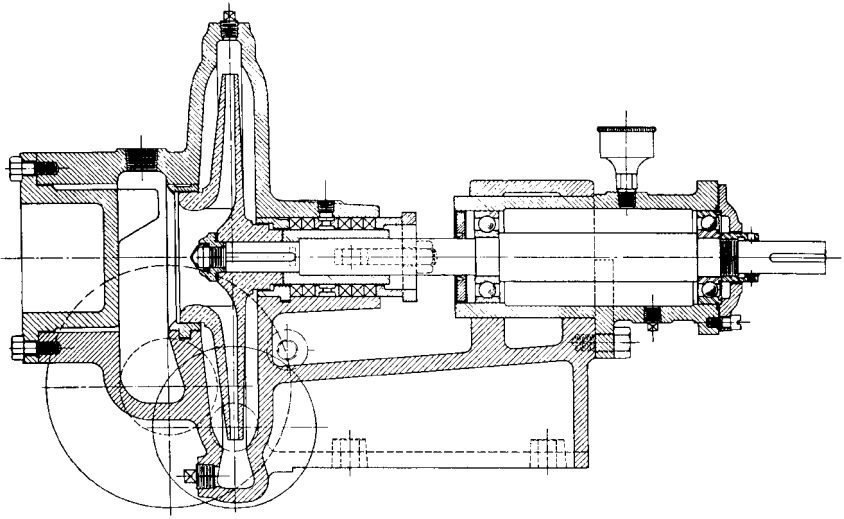


FIGURE 32 Single-stage horizontal condensate pump with axially split casing (Flowserve Corporation)

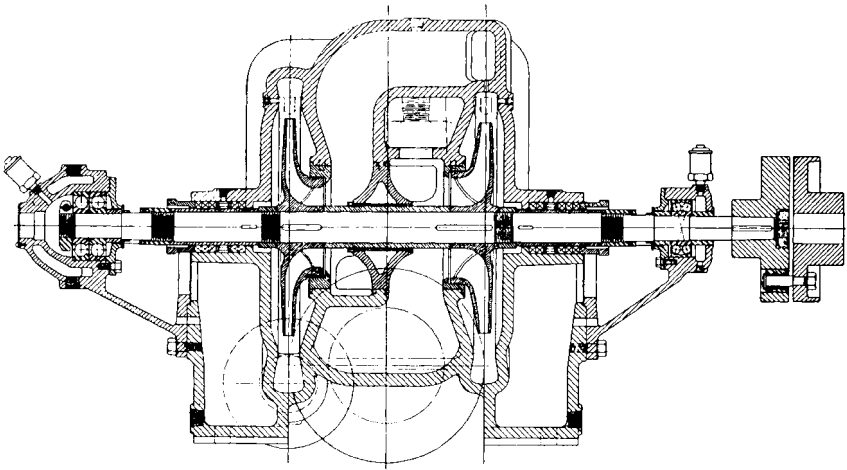


FIGURE 33 Two-stage horizontal condensate pump with axially split casing (Flowserve Corporation)

The increasing use of full-flow demineralizers in condensate systems and, in the 1960s, the increasing discharge pressures required from the condensate pumps resulted in the need to split condensate pumping into two parts. The condensate pumps proper thus develop only a small portion of the total head required. The balance of the required head was provided by separate condensate booster pumps, which have generally been of the conventional horizontal, axially split casing type. As larger plants were constructed, the vertical can-type multistage condensate pump became the standard.

To prevent air leakage at the stuffing boxes, condensate pumps equipped with packing are always provided with seal cages. The water used for gland sealing must be taken from

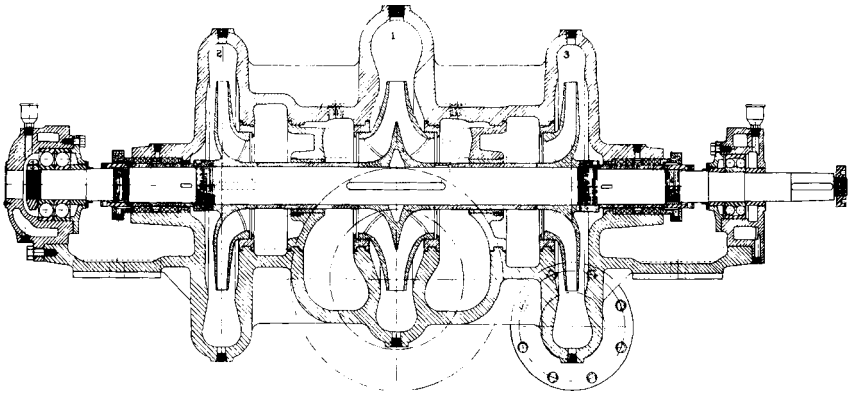


FIGURE 34 Three-stage horizontal condensate pump with axially split casing (Flowserve Corporation)

the condensate pump discharge manifold beyond all the check valves. Pumps fitted with mechanical seals also use injection of condensate at a pressure higher than atmospheric pressure to prevent air from being drawn into the pump and feedwater system across the seal faces.

Condensate pumps were supplied with cast iron casings and bronze internal parts, but the emergence of once-through boilers has created the need to eliminate all copper alloys in the condensate system to avoid deposition of copper on the boiler tubes. Stainless steel-fitted pumps have become the standard selection for this service.

**Condensate Pump Regulation** When a condensate pump operates in a closed cycle ahead of the boiler-feed pump, the two pumps can be considered as a combined unit insofar as their head-capacity curve is concerned. Variation in flow is accomplished either by throttling the boiler-feed pump discharge or by varying the speed of the boiler-feed pump.

In an open feedwater system, several means can be used to vary the condensate pump capacity with the load:

1. The condensate pump head-capacity curve can be changed by varying the pump speed.
2. Older plant condensate pump head-capacity curves are altered by allowing the pump to operate in the "break" (Figures 35 and 36).
3. The system-head curve can be artificially changed by throttling the pump discharge by means of a float control.
4. The pump can operate at the intersection of its head-capacity curve and the normal system-head curve. The net discharge is controlled by bypassing all excess condensate back to the condenser hot well.
5. Methods 3 and 4 can be combined so the discharge is throttled back to a predetermined minimum, but if the load, and consequently the flow of condensate to the hot well, are reduced below this minimum, the excess condensate handled by the pump is bypassed back to the hot well.

The impulse for the controls used in methods 1, 3, and 4 is taken from the deaerator level.

Operating in the break, or "submergence control" as it has often been called, was applied successfully in many installations before the 1960s. Condensate pumps designed for submergence control require specialized hydraulic design, correct selection of operating speeds, and limitation of stage pressures. The pump is operating in the break (that is, cavitates) at all capacities. However, this cavitation is not severely destructive because the energy level of the fluid at the point where the vapor bubbles collapse is insufficient to cre-



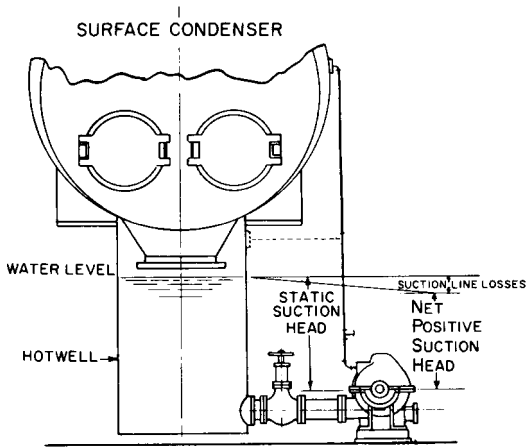


FIGURE 35 Typical hookup for submergence controlled condensate pump

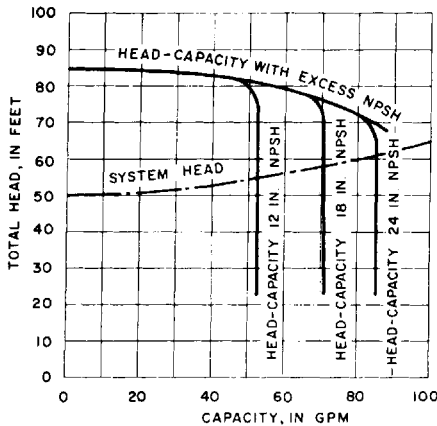


FIGURE 36 Characteristic of a condensate pump operating on a submergence-controlled system

ate a shock wave of a high enough intensity to inflict physical damage on the pump parts. If, however, higher values of  $NPSH$  were required—as for instance with vertical-can condensate pumps because of their generally higher operating speed—operation in the break would result in a rapid deterioration of the impellers. It is for this reason that submergence control is not applicable to can-type condensate pumps.

The main advantage of submergence control was its simplicity and the fact that the power required for any operating condition was less than with any other system. Disadvantages occur when the pump is operating at very light loads, however, because the system head may require as little as one-half of the total head produced in the normal head-capacity curve. In this case, the first stage of a two-stage pump produces no head whatsoever and, if the axial balance was achieved by opposing the two impellers, a definite thrust is imposed on the thrust bearing, which must be selected with sufficient capacity to withstand this condition. In addition, no control is available to provide the minimum flow that may be required through the auxiliaries, such as the ejector condenser.

The condensate pump discharge can be throttled by a float control arranged to position a valve that increases the system-head curve as the level in the hot well is drawn down. This eliminates the cavitation in the condensate pump, but at the cost of a slight power increase. Furthermore, the float necessarily operates over a narrow range, and the mechanism tends to be somewhat sluggish in following rapid load changes, often resulting in capacity and pressure surges. This transient condition is often the root cause of failed thrust bearings and axial rotor shifting. Another critical piping arrangement feature is the discharge piping check valve. The check valve in every condensate pump must be below the condenser hotwell level to ensure prevention of air entrapment and start-up waterhammer. [Refer to Section 8.3.]

When condensate delivery is controlled through bypassing, the hot well float controls a valve in a bypass line connecting the pump discharge back to the hot well. At maximum condensate flow, the float is at its upper limit with the bypass closed and all the condensate is delivered to the system. As the condensate flow to the hot well decreases, the hot well level falls, carrying the float down and opening the bypass. Sluggish float action can create the same problems of system instability in bypass control as in throttling control, however, and the power consumption is excessive because the pump always operates at full capacity.

A combination of throttling and bypassing control eliminates the shortcoming of excessive power consumption. The minimum flow at which bypassing begins is selected to provide sufficient flow through the ejector condenser.

A modification of the bypassing control for minimum flow is illustrated in Figure 37, which shows a thermostatic control for condensate recirculation. With practically constant steam flow through the ejector, the rise in condensate temperature between the inlet and outlet of the ejector condenser is a close indication of condensate flow rate through the ejector condenser tubes. Therefore an automatic device to regulate the condensate flow rate can be controlled by this temperature differential. A small pipe is connected from the condensate outlet on the ejector condenser back into the main condenser shell. An automatic valve is installed in this line and is actuated and controlled by the temperature rise of the condensate. Whenever the temperature rises to a certain predetermined figure, indicating a low flow of condensate, the automatic valve begins to open, allowing some of the condensate to return to the condenser and then to the condensate pump, which supplies it to the ejector at the increased rate. When the temperature rise through the ejector condenser is less than the limiting amount, indicating that ample condensate is flowing through the ejector condenser, the automatic valve remains closed.

As condensate flow design demand increased, the vertical multistage pumps were installed as two half-capacity pumps. Flow variation is accomplished by operating one or two pumps and by utilizing the regulating discharge valve.

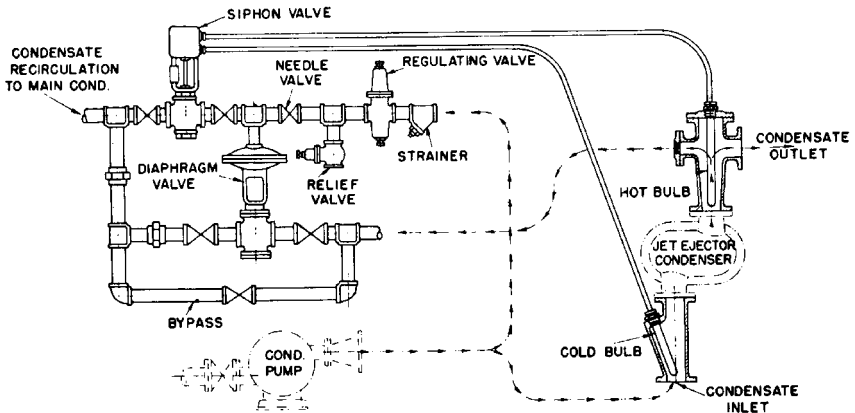


FIGURE 37 Thermostatic control for condensate recirculation

Just as in the case of boiler-feed pumps—or, as a matter of fact, of any pumps—condensate pumps should not be operated at shutoff or even at certain reduced flows. This subject is covered in detail in Subsections 2.3.1 and 2.3.4. Emphasis is placed on the importance of preventing “dead-heading,” where the weaker pump in a two-pump system with only one minimum flow protection loop is forced to operate at shut-off or zero flow rate.

## HEATER DRAIN PUMPS

**Service Conditions** Condensate drains from closed heaters can be flashed to the steam space of a lower-pressure heater or pumped into the feedwater cycle at some higher-pressure point. Piping each heater drain to the heater having the next lower pressure is the simpler mechanical arrangement and requires no power-driven equipment. This “cascading” is accomplished by an appropriate trap in each heater drain. A series of heaters can thus be drained by cascading from heater to heater in the order of descending pressure, the lowest being drained directly to the condenser.

This arrangement, however, introduces a loss of heat because the heat content of the drains from the lowest-pressure heater is dissipated in the condenser by transfer to the circulating water. It is generally the practice, therefore, to cascade only down to the lowest-pressure heater and pump the drains from that heater back into the feedwater cycle, as shown in Figure 38. Because the pressure in that heater hot well is low (frequently below atmospheric even at full load), heater drain pumps on that service are commonly described as on “low-pressure heater drain service.”

In an open cycle, drains from heaters located beyond the deaerator are cascaded to the deaerator. Although the deaerator is generally located above the closed heaters, the difference in pressure is sufficient to overcome both the static and the frictional losses. This difference in pressure decreases with a reduction in load, however, and at some partial main turbine load it becomes insufficient to evacuate the heater drains. They must be switched to a lower-pressure heater or even to the condenser, with a subsequent loss of heat. To avoid these complications, a “high-pressure heater drain pump” is generally used to transfer these drains to the deaerator. Actually, this pump has a “reverse” system head to work against; at full load, the required total head may be negative, whereas at light loads, the required head is at its maximum.

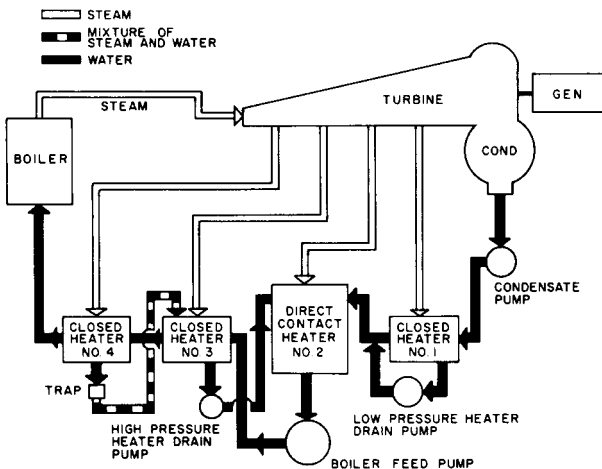


FIGURE 38 Typical arrangement for heater drain pumps

High-pressure drain pumps are subject to more severe conditions than boiler-feed pumps encounter:

1. Their suction pressure and temperature are higher.
2. The available *NPSH* is generally extremely limited.
3. They are subject to all the transient conditions to which the feed pump is exposed during sudden load fluctuations, and these transients are more severe than those at the feed pump suction.

**Types of Heater Drain Pumps** In the past, heater drain pumps were often horizontal, either single-stage or multistage, depending upon total head requirements. In the single stage type, end-suction pumps of the heavier “process pump” construction (Figure 43) were preferred for both low- and high-pressure service. Current construction features the vertical can-type pump (Figure 30) on heater drain services. As previously described, the advantages of the vertical can pump are lower first cost and a built-in additional *NPSH* because the first-stage impeller is lowered below floor level in the can. Against these advantages, one must weigh certain shortcomings. A horizontal heater drain pump is more easily inspected than a can pump. The external grease- or oil-lubricated bearings of the horizontal pump are less vulnerable to the severe operating conditions during swinging loads than the water-lubricated internal bearings of the can pump. If vertical can heater drain pumps have a bearing in the suction bell, consideration must be given to the fact that the water in the immediate location of that bearing is at near saturated pressure and temperature conditions (high temperature and low pressure). To keep the water in the bearing from flashing, additional water should be piped back to the bearing from a higher stage.

Heater drain pumps should be adequately vented to the steam space of the heater. Because heater drain pumps and especially those on low-pressure service may operate with suction pressures below atmospheric, it is necessary to provide a liquid supply to the seal cages in the stuffing boxes. Low-pressure heater drain pumps use cast iron casings and bronze fittings if no evidence of corrosion erosion has been uncovered. On high-pressure services, stainless steel components are generally mandatory and 12% chrome stainless steel casings are preferred.

## CONDENSER CIRCULATING PUMPS

---

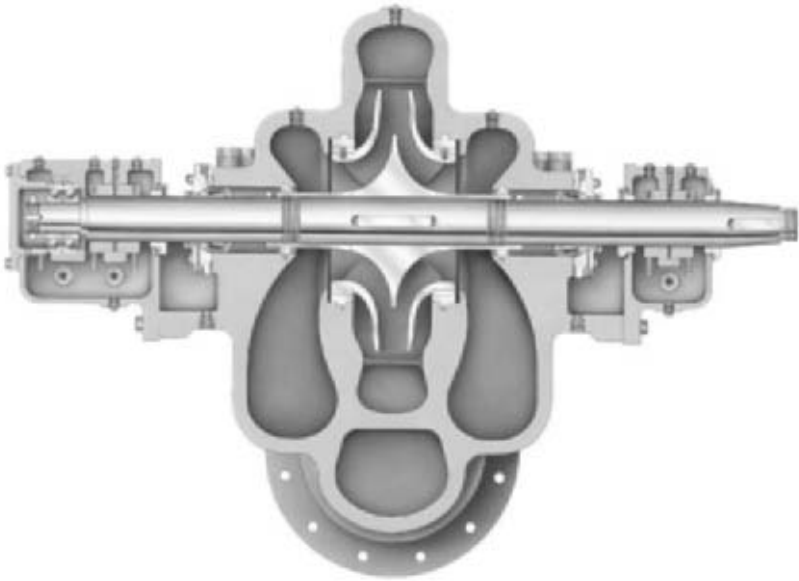
**Types of Pumps** Condenser circulating pumps may be of either horizontal or vertical construction. For many years, the low-speed, horizontal, double-suction volute centrifugal pump (Figure 39) was the preferred type. This pump has a simple but rugged design that allows ready access to the interior for examination and rapid dismantling if repairs are required.

The larger central station and combined cycle power plants have switched to wet-pit vertical pumps that are either fully or partially submerged in the water pumped. Central stations also installed vertical dry-pit pumps in the 1950s and 1960s. These dry-pit designs are large vertical volute casing pumps surrounded by air.

**Mechanical Considerations** The dry-pit installation was a single-suction, medium-specific-speed, mixed-flow pump (Subsection 2.2.1, Figure 109). This design combined the high efficiency and low maintenance of the horizontal double-suction radial-flow centrifugal pump with lower cost and slightly higher rotative speeds.

Because of their suction and discharge nozzle arrangements, these pumps are ideally suited for vertical mounting in a dry pit, preferably at the lowest water level, so they are self-priming on starting. They are directly connected to solid-shaft induction or synchronous motors, either close-coupled or with intermediate shafting between the pump and the motor, which is then mounted well above the pump pit floor.

Like the horizontal double-suction pump, the vertical dry-pit mixed-flow pump is a compact and sturdy piece of equipment. Its rotor is supported by external oil-lubricated bearings



**FIGURE 39** Horizontal double suction single stage pump, IDP model LN (Flowserve Corporation)

of optimum design. This construction requires the least attention, for the oil level can be easily inspected by means of an oil sight glass mounted at the side of the bearing or oil reservoir.

Because the rotor is readily removed through the top of the casing, facilitating maintenance and replacement, the pump does not have to be removed from its mounting and the suction and discharge connections do not have to be broken to make periodic inspections or repairs.

In recent years, power plant designers have shown a preference for the wet-pit column-type condensate circulating pump. The term *wet-pit* normally implies a casing diffuser-type pump, employing a single open vane impeller. The wet-pit pump (Figure 40) employs a long column pipe that supports the submerged pumping element. It is available with open main shaft bearings lubricated by the water handled, or with enclosed shafting and bearings, lubricated by clean, fresh, filtered water from an external source. There is some danger of contamination of the lubricating water from seepage into the shaft enclosure tube during shut-downs.

Pulling up the column in a long pump requires special facilities and, in addition, the discharge flange must be disconnected when withdrawing the pump and column from the pit. This design has been designated a “non-pull-out” design (Figure 40). To avoid the necessity of lifting the entire pump when the internal parts require maintenance, some units are built so the impeller, impeller shroud, casing, and shaft assembly can be removed from the top without disturbing the column pipe assembly. (The driving motor must be removed.) These designs are commonly designated “pull-out” designs (Figure 41).

Condenser cooling water is often corrosive. Power plants are often located near salt or brackish bodies of water. Plants near rivers often encounter water contaminated with high silt levels. With such waters, selection of materials can be critical to long service life. Material selection for sea water applications must also consider the potential for electrolytic (galvanic) corrosion.

**Performance Characteristics** Condenser circulating pumps are normally required to work against low or moderate heads. Extreme care should be exercised in calculating the system frictional losses, which include losses from friction in the condenser. If more total



**FIGURE 40** Vertical wet pit circulating water pump (non-pull-out) (Flowsolve Corporation)

head is specified than is required, the resulting driver size may be unnecessarily increased. For instance, an excess of 1 or 2 ft (0.3 or 0.6 m) in an installation requiring only 20 ft (6 m) of head represents an increase of 5 to 10% in excess power costs.



**FIGURE 41** Vertical wet pit circulating water pump (pull-out) (Flowsolve Corporation)

The range of suction lift for dry-pit pumps must be determined very accurately and checked with the manufacturer to ensure that cavitation will be avoided in the installation. Priming facilities must be provided, or the pump must be installed in a dry pit at such an elevation that the water in the suction channel leading to the pump will be maintained at the level recommended by the manufacturer. This presents no problem in a wet-pit installation because the pump column can be made long enough to provide adequate submergence, even with minimum water levels in the suction well or pit. The dry-pit pump will generally have 3 to 4% higher efficiency than the wet-pit type and therefore 3 to 4% lower power consumption. The two types are available for the same specific speed range. When pumping total head is 25 ft (7.6 m) or less, an axial-flow propeller (approximately 10,000 specific speed in USCS units) can be used in either type of pump.

The low-specific-speed, double-suction pump has a very moderate rise in head with reducing capacities and a nonoverloading power curve with a reduction in head. The mixed-flow impeller with a higher specific speed has a steeper head-capacity curve and a reasonably flat power curve that is also nonoverloading. As the specific speed increases, the steepness of the head-capacity curve increases and the curvature of the power curve reverses itself, hitting a maximum at the lowest flow. Finally, the curve of a high-specific-speed propeller pump has the highest rise in both head-capacity and power-capacity curves toward zero flow. The head range developed by the mixed-flow pump is ideal for condenser service; this pump is usually furnished with an enclosed impeller, which produces a relatively flat head-capacity curve and a flat power characteristic.

Higher head circulating water pumps were developed in the 1970s as cooling towers were introduced to improve plant efficiency and environmental contamination. The cooling tower arrangement effectively increased the total system resistance head requirements.

**System Hydraulics** The dry-pit pump is not too sensitive to the suction well design because the inlet piping and the formed design of the suction passages into the pump normally ensure a uniform flow into the eye of the impeller. On the other hand, the higher-speed wet-pit pumps are more sensitive to departures from ideal inlet conditions than the low-speed centrifugal volute pump or the medium-speed mixed-flow pump. A discussion of the arrangements recommended for wet- and dry-pit pump installations is presented in Section 10.1.

**Drivers** Whether a dry-pit or a wet-pit pump is used, the axial thrust and weight of the pump rotor are normally carried by a thrust bearing in the motor, and the driver and driven shafts are connected through a rigid coupling. The higher rotative speeds of the wet-pit pumps reduce the cost of the electric motors somewhat. This difference may be offset, however, by the fact that the thrust load of the wet-pit pump is higher than that of the dry-pit pump.

## **BOILER CIRCULATING PUMPS**

---

The forced circulation, or controlled circulation, boiler requires the use of circulating pumps that take their suction from a header connected to several downcomers, which originate from the bottom of the boiler drum and discharge through the various tube circuits operating in parallel (Figure 42). The circulating pumps therefore must develop a pressure equivalent to the frictional losses through these tube circuits. Thus, in the case of different boilers operating in pressure ranges from 1800 to 3000 lb/in<sup>2</sup> (124 to 207 bar), the boiler circulating pump must handle feedwater from 620 to 690°F (326 to 365°C) under a suction pressure of 1800 to 2900 lb/in<sup>2</sup> (124 to 200 bar). Such a combination of high suction pressure and high water temperature at saturation imposes very severe conditions on the circulating pump stuffing boxes, making it necessary to develop special designs for this part of the pump.

The net pressure to be developed by these pumps is relatively low, ranging from 50 to 150 lb/in<sup>2</sup> (3.4 to 10.3 bar). Hence these are single-stage pumps with single-suction impellers and a single stuffing box. The high boiler pressure imposes an extremely severe axial thrust on the



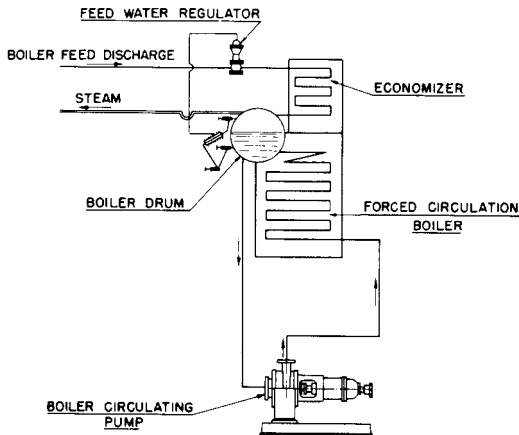
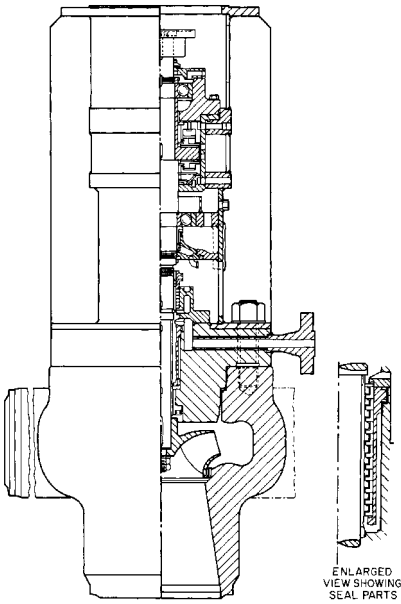


FIGURE 42 Forced, or controlled, circulation system

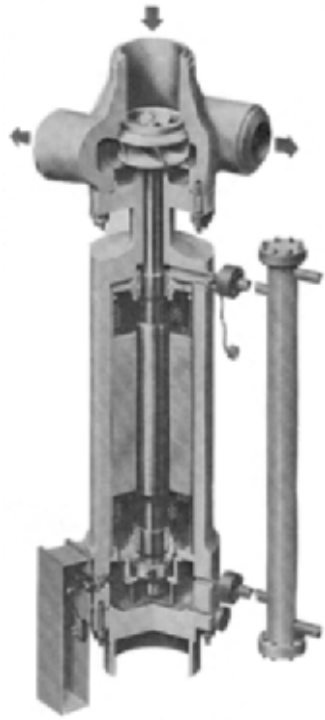
pump, placing a load of several tons on the thrust bearing. In many cases, a thrust-relieving device must be incorporated to permit pump start-up. Two general types of construction are used for this service: (1) the conventional centrifugal pump with various stuffing box modifications (Figure 43) and (2) the submersible motor pump of either the wet- or dry-stator type (Figure 44). In the lower boiler pressure range up to 500 or 600 lb/in<sup>2</sup> gauge (34 or 41 bar), the construction shown in Figure 45 may be used. The pump is of the same general type as is used on high-pressure heater drain service. The packed stuffing box or mechanical seal is preceded by a pressure-reducing bushing. Feedwater from the boiler-feed pump discharge, at a temperature lower than in the boiler drum and at a pressure somewhat higher than pump internal pressure, is injected into the middle of this bushing. Part of this injected feedwater proceeds toward the pump interior, making a barrier against the outflow of high-temperature water. The rest proceeds outward to a bleed portion of the bushing, from where it is bled to a lower pressure, often the deaerator. The packing or mechanical seal needs to withstand only the lower boiler-feed pump temperature and a much lower pressure than boiler pressure.

More sophisticated designs are required for pressures from 1800 to 3000 lb/in<sup>2</sup> gauge (124 to 207 bar) (Figure 43). The shaft is sealed by two floating ring pressure breakdowns and a water-jacketed stuffing box. Boiler feedwater is injected at a point between the lower and upper stacks of floating ring seals at a pressure about 50 lb/in<sup>2</sup> (3.5 bar) above the pump internal pressure. Here again, part of this injection leaks into the pump interior and the rest leaks past the upper stack of seals to a region of low pressure in the feed cycle. Leakage to atmosphere is controlled by the conventional stuffing box located above the upper stack. The seal injection and leakoff control system is very sensitive to boiler and feedwater pump transients. Loss of injection results in flashing in the sealing chamber and failure of the sealing rings. Current technology utilizes a two-stage, high-pressure mechanical seal. This eliminates the need for a separate seal injection system and seal-injection booster pump.

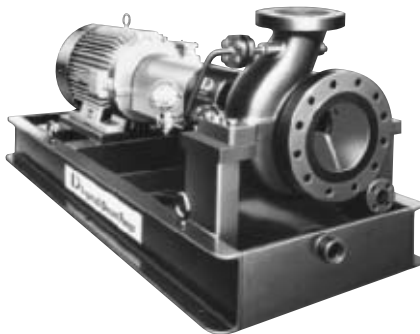
The available *NPSH* may not be sufficient at start-up, when the water in the boiler is cold and the pressure is low. Therefore certain installations include two-speed motors so a lower *NPSH* is required at start-up. There is an added advantage to this arrangement: under normal operating conditions, the feedwater will heat boiler saturation temperature and therefore will have a specific gravity of as low as 0.60; at start-up, however, the specific gravity will be 1.0. The power consumption on cold water would therefore be some 65% higher than in normal operation if the pump operates at the same speed, and a much larger motor would be required. If a two-speed motor is used, however, the pump is operated at lower speed when the water is cold, and the motor need be only large enough to supply the maximum power required under normal operating conditions.



**FIGURE 43** Vertical injection-type boiler circulating pump for high pressures (Flowsolve Corporation)



**FIGURE 44** Boiler circulating pumps driven by a wet stator motor (Hayward Tyler)



**FIGURE 45** End-suction boiler circulating pump for low-pressure range (Flowsolve Corporation)

## ASH-HANDLING PUMPS

Boilers that use solid fossil fuels produce refuse that is generally classified as ash and includes bottom ash or slag, fly ash, and mill rejects such as pyrites and so on. This refuse



**FIGURE 46** Horizontal single stage double suction, high head pump (FlowsERVE Corporation)

must be removed and disposed of, either by hydraulic or pneumatic conveying. The latter, of course, does not involve the use of pumps and need not be discussed here.

Fly ash and bottom ash is removed from the boiler system through a series of water ejectors. Centrifugal pumps provide the water, taken from either the circulating water pump header or ash-settling pond. These pumps (Figure 46) are subjected to severe duty as pump flows vary significantly and the pumpage is often contaminated with suspended silt or fly ash.

Hydraulic conveying is generally restricted to bottom ash and mill rejects. There are a great number of different systems in use today, and the reader should consult boiler design and operation literature to become acquainted with this subject. What is common to most hydraulic conveying systems is that they use centrifugal pumps to handle concentrated ash slurries that may contain considerable amounts of coarse, heavy pieces of stone, slate, and iron pyrites. Pumps suitable for this service are described in detail in Subsection 9.16.2.

## REFERENCES

---

Liao, C. S., and Leung, P. "Analysis of Feedwater Pump Suction Pressure Decay." *ASME J. Eng. Power*; April 1972, p. 33.

Liao, C. S. "Protection of Boiler Feed Pump Against Transient Suction Pressure Decay." *ASME J. Eng. Power*; July 1974, p. 247.

## FURTHER READING

---

Karassik, I. J. "Steam Power Plant Clinics." A series of articles in *Combustion Engineering*, 1958 through 1976.

---

# SECTION 9.6

---

# CHEMICAL INDUSTRY

---

JOHN R. BIRK  
JAMES H. PEACOCK  
FREDERIC W. BUSE

---

## **SOLUTION CHARACTERISTICS**

---

Chemical industries can be broadly defined as those that make, use, or dispose of chemicals. The pumps used in these industries are different from those used in other industries primarily in the materials from which they are made. Although cast iron, ductile iron, carbon steel, and aluminum- or copper-base alloys will handle a few chemical solutions, most chemical pumps are made of stainless steel, Hastelloy, the nickel-base alloys, or the more exotic metals, such as titanium and zirconium. Pumps are also available in carbon, glass, porcelain, rubber, lead, and whole families of engineering polymers, including the thermoplastics, thermosets, epoxies, and fluorocarbons. Each of these materials has been incorporated into pump design for just one reason—to eliminate or reduce the destructive effect of the chemical liquid on the pump parts.

Because the type of corrosive liquid to be pumped determines which of these materials is most suitable, a careful analysis of the chemical solution to be handled is the first step in selecting the proper materials for pump construction.

**Major and Minor Constituents** Foremost in importance in a study of the characteristics of any solution are the constituents of the solution. This means not only the major constituents but the minor ones as well, for in many instances the minor constituents will be the more important. They can drastically alter corrosion rates, and therefore a full and detailed analysis is most critical.

**Concentration** Closely allied to what the constituents are is the concentration of each. Merely stating “concentrated,” “dilute,” or “trace quantities” is basically meaningless because of the broad scope of interpretation of these terms. For instance, some interpret *concentrated* as meaning any constituent having a concentration of greater than 50% by weight, whereas others interpret any concentration above 5% in a like manner. Hence it

is always desirable to cite the percentage by weight of each and every constituent in a given solution. This eliminates multiple interpretations and permits a more accurate evaluation. It is also recommended that the percentage by weight of any trace quantities be cited, even if this involves only parts per million. For example, high-silicon iron might be completely suitable in a given environment in the absence of fluorides. If, however, the same environment contained even a few parts per million of fluorides, the high-silicon iron would suffer a catastrophic corrosion failure.

**Temperature** Generalized terms such as *hot*, *cold*, or even *ambient* are ambiguous. The preferred terminology would be the maximum, minimum, and normal operating temperature. In general, the rate of a chemical reaction increases approximately two to three times with each 18°F (10°C) increase in temperature. Because corrosion can be considered a chemical reaction, the importance of temperature or temperature range is obvious.

A weather-exposed pump installation is a good illustration of the ambiguity of the term *ambient*. There could be as much as a 150°F (83°C) difference between an extremely cold climate and an extremely warm climate. If temperature cannot be cited accurately, the ambient temperature should be qualified by stating the geographic location of the pump. This is particularly important for materials that are subject to thermal shock in addition to increased corrosion rate at higher temperatures.

**Acidity and Alkalinity** More often than not, little consideration is given to the pH of process solutions. This may be a critical and well-controlled factor during production processing, and it can be equally revealing in evaluating solution characteristics for material selection. One reason the pH may be overlooked is that it generally is obvious whether the corrosive substance is acidic or alkaline. However, this is not always true, particularly with process solutions in which the pH is adjusted so the solutions will always be either alkaline or acidic. When this situation exists, the precise details should be known so a more thorough evaluation can be made. It is also quite important to know when a solution alternates between acidic and alkaline conditions because this can have a pronounced effect on materials selection. Some materials, although entirely suitable for handling a given alkaline or acidic solution, may not be suitable for handling a solution whose pH is changing.

**Solids in Suspension** Erosion-corrosion, velocity, and solids in suspension are closely allied in chemical industry pump services. Pump design is a very critical factor when the solution to be pumped contains solids. It is not uncommon for a given alloy to range from satisfactory to completely unsatisfactory in a given chemical application when hydraulic design is the only variable. Failure to cite the presence of solids on a solution data sheet is not an uncommon occurrence. The concentration of solids should be referred to as percent by volume or weight. This undoubtedly is the reason for many catastrophic erosion-corrosion failures.

**Aerated or Non-aerated** The presence of air in a solution can be quite significant. In some instances, it is the difference between success and failure in that it can conceivably render a reducing solution oxidizing and require an altogether different material for pump construction. A good example of this would be a self-priming nickel-molybdenum-alloy pump for handling commercially pure hydrochloric acid. This alloy is excellent for the commercially pure form of this acid, but any condition that can induce even slightly oxidizing tendencies renders this same alloy completely unsuitable. The very fact that the pump is a self-primer means that aeration is a factor to contend with, and extreme caution must be exercised in using an alloy that is not suitable for an oxidizing environment. The presence of air will not only affect the head-flow rate performance, but also the *NPSHR*. The maximum amount of air a conventional centrifugal pump can handle is approximately five percent by volume.

**Transferring or Recirculating** This item is important because of the possible buildup of corrosion product or contaminants, which can influence the service life of the pump.

Such a buildup of contaminants can have a beneficial or deleterious effect, and for this reason it should be an integral part of evaluating solution characteristics.

**Inhibitors or Accelerators** Both inhibitors and accelerators can be intentionally or unintentionally added to the solution. Inhibitors reduce corrosivity, whereas accelerators increase corrosivity. Obviously, no one would add an accelerator to increase the corrosion rate on a piece of equipment, but a minor constituent added as a necessary part of a process may serve as an accelerator; thus the importance of knowing the presence of such constituents.

**Purity of Product** Where purity of product is of absolute importance, particular note should be made of any element that may cause contamination problems, whether it be discoloration of product or solution breakdown. In some environments, pickup of only a few parts per billion of certain elements can create severe problems. This effect is particularly important in pump applications where velocity effects and the presence of solids can alter the end result, as contrasted with other types of process equipment where the velocity or solids may have little or no effect.

When a material is basically suitable for a given environment, purity of product should not be a problem. However, this cannot be an ironclad rule, particularly with chemical pumps.

**Continuous or Intermittent Duty** Depending upon the solution, continuous or intermittent contact can have a bearing on service life. Intermittent duty in some environments can be more destructive than continuous duty if the pump remains half full of corrosive during periods of downtime and accelerated corrosion occurs at the air-liquid interface. Perhaps of equal importance is whether the pump is flushed or drained when not in service.

## CORROSIVES AND MATERIALS

---

**Metallic or Nonmetallic** Materials for chemical industry pump applications can, in general, be divided into two very broad categories: metallic and nonmetallic. The metallic category can be further divided into ferrous and nonferrous alloys, both of which have extensive application in the chemical industry. The nonmetallic category can be further divided into natural and synthetic rubbers, polymers, ceramics and glass, carbon and graphite, and wood. Of these nonmetallic materials, wood, of course, has little or no application for pump services. The other materials have definite application in the handling of heavy corrosives. In particular, polymers in recent years have gained widespread acclaim for their ability to handle chemicals. For a given application, a thorough evaluation of not only the solution characteristics but also the materials available should be made to ensure the most economical selection.

**Source of Data** To evaluate material for chemical pump services, various sources of data are available. The best source is previous practical experience within one's own organization. It is not unusual, particularly in large organizations, to have a materials group or corrosion group whose basic responsibility is to collect and compile corrosion data pertaining to process equipment in service. These sources should be consulted whenever a materials evaluation program is being conducted. A second source of data is laboratory and pilot-plant experience. Though the information from this source cannot be as valuable and detailed as plant experience, it certainly can be very indicative and serve as an important guide. The experience of suppliers can be a third source of information. Though suppliers cannot hope to provide data on the specific details of a given process and the constituents involved, they normally can provide assistance and materials for test to facilitate a decision. Technical journals and periodicals are a fourth source of information. A wealth of information is contained in these publications, but if an excellent information retrieval system is not available, it can be very difficult to locate the information desired.

Reams of information have been published in books, tables, charts, periodicals, bulletins, and reports pertaining to materials selection for various environments. It is not the intent of this section of the handbook to make materials recommendations. However, it is deemed advisable to provide some general comments and to point out a few applications having unusual characteristics. The Hydraulic Institute Standards present a very comprehensive guide for polymer material selection.

**Sulfuric Acid** This is the most widely used chemical in industrial applications today, and much time is spent in evaluating and selecting materials for applications involving sulfuric acid with and without constituents. The following are some of the applications that merit special consideration.

**DILUTION OF COMMERCIAL PURE SULFURIC ACID** When sulfuric acid is diluted with water, there is considerable evolution of heat. At times, the mixing of the acid and water takes place not in the mixing tank but in the pump transferring the acid. This means that heat is evolved as the solution is passing through the pump. Temperatures of 200°F (93°C) or higher are reached, depending upon the degree of dilution and the amount of mixing taking place in the pump. Thus, the heat evolved in the dilution would restrict material selection. Very few metallics or nonmetallics are resistant to 70% sulfuric acid at temperatures approaching 200°F (93°C). Refer to Section 5.2 for material guidelines for sulfuric acid.

**SULFURIC ACID SATURATED WITH CHLORINE** It is a well-known fact that any solution involving wet chlorine is extremely corrosive. In a solution containing sulfuric acid and chlorine, the specific weight percentage of sulfuric acid determines whether the solution will accelerate corrosion. Because of the hygroscopic nature of concentrated sulfuric acid, it will absorb moisture from the chlorine. Thus, when a sulfuric acid-chlorine solution contains at least 80% sulfuric acid, there need be little concern for the chlorine because dry chlorine is essentially noncorrosive. In such a case, a material selection can be made as if sulfuric acid were the only constituent. If the solution is saturated with chlorine but contains less than approximately 80% sulfuric acid; however, the material selection must be based not only on the sulfuric acid but also on the wet chlorine. This, of course, is a very corrosive solution, and extreme caution must be exercised in selecting the material to be used.

**SULFURIC ACID CONTAINING SODIUM CHLORIDE** It is quite apparent that the addition of sodium chloride to sulfuric acid will result in the formation of hydrochloric acid and thus necessitate a material that will resist the corrosive action of hydrochloric acid also. Though this may seem obvious, it is amazing how often it is ignored. This is particularly true in 10 to 15% sulfuric acid pickling solutions to which sodium chloride has been added to increase the rate of pickling, with little or no consideration being given to the destructive effect of the salt on the process equipment handling the pickling solution.

**PIGMENT MANUFACTURE** A slurry of titanium dioxide in sulfuric acid is one of the processing stations in the manufacture of pigment. A variety of metallics and nonmetallics would be suitable for this application in the absence of the titanium dioxide solids, but the presence of the solids circulating in a pump renders practically all of the normal sulfuric acid-resistant pump materials unsuitable. Special consideration must be given to materials that will resist the severe erosion-corrosion encountered in this type of service.

**SULFURIC ACID CONTAINING NITRIC ACID, FERRIC SULFATE, OR CUPRIC SULFATE** The presence of these compounds in sulfuric acid solutions will drastically alter the suitability of materials that can be used. Their presence in quantities of 1% or less can make a sulfuric acid solution oxidizing, whereas it would normally be reducing. Their presence, singly or in combination, could serve as a corrosion inhibitor, thus in certain instances allowing a stainless steel, such as type 316, to be used. On the other hand, the same compounds could serve as a corrosion accelerator for a non-chromium bearing alloy, such as nickel-molybdenum alloys, and thus render it completely unsuitable.

**Nitric Acid** In the concentrations normally encountered in chemical applications, nitric acid presents fewer problems than sulfuric acid. The choice of metallic materials for various nitric applications is somewhat broader than the choice of nonmetallic materials. Nitric acid, being a strongly oxidizing acid, permits the use of stainless steel quite extensively, but its oxidizing characteristics restrict the application of nonmetallics in general and plastics in particular. Requiring special evaluation are such aggressive solutions as fuming nitric acid; nitric-hydrofluoric; nitrichydrochloric (some of which fall into the aqua regia category); nitric-adipic combinations; and practically any environment consisting of nitric acid in combination with other constituents. Invariably, additional constituents in nitric acid result in more aggressive corrosion; hence material selection becomes quite critical.

**Hydrochloric Acid** Both commercially pure and contaminated hydrochloric acid present difficult situations in selecting pump materials. The most common contaminant that creates problems is ferric chloride, the presence of which can render this otherwise reducing solution oxidizing and thus completely change the material of construction that can be used. Addition of a very few parts per million of iron to commercially pure hydrochloric acid can result in the formation of enough ferric chloride to cause materials such as nickel-molybdenum, nickel-copper, and zirconium to be completely unsuitable. Conversely, the presence of ferric chloride can make titanium completely suitable. Nonmetallics find extensive application in many hydrochloric acid environments. Often the limiting factors for the nonmetallics are temperature, mechanical properties, and suitability for producing pump parts in the design desired. With the nonmetallics, the near-complete immunity from corrosion in such environments subordinates corrosion resistance to other factors. Refer to Section 5.2 for material guidelines for hydrochloric acid.

**Phosphoric Acid** The increasing use and demand for all types of fertilizers have made phosphoric acid a very important commodity. In the wet process of producing phosphoric acid, the phosphate rock normally contains fluorides. In addition, at various stages of the operation the solution will also contain sulfuric, hydrofluoric, fluosilicic, and phosphoric acids as well as solids. In some instances, the water used in these solutions may have an exceptionally high chloride content, which can result in the formation of hydrochloric acid, which further aggravates the corrosion problem. It is also common for certain of these solutions to contain solids, which of course create an erosion-corrosion problem. Pure phosphoric and superphosphoric acids are relatively easy to cope with from a material standpoint, but when the solution contains all or some of the aforementioned constituents, a very careful materials evaluation must be conducted. Such environments are severely corrosive in the absence of solids and cause severe erosion-corrosion and a drastically reduced service life when solids are present. This is particularly significant with any type of chemical pump.

**Chlorine** Little need be said about the corrosivity of chlorine. Wet chlorine, in addition to being extremely hazardous, is among the most corrosive environments known. Dry chlorine is not corrosive, but there are those who contend that dry chlorine does not exist. Chlorine vapor combined with the moisture in the atmosphere, for instance, can create severe corrosion problems. In any case, selecting the most suitable material for any type of chlorine environment requires very careful evaluation.

**Alkaline Solutions** With some exceptions, alkaline solutions, such as sodium hydroxide or potassium hydroxide, do not present serious corrosion problems at temperatures below 200°F (93°C). However, in certain applications, purity of product is of utmost concern, necessitating selection of a material that will have essentially no corrosion rate. Among the exceptions to the rule that alkaline solutions are relatively noncorrosive are bleaches, alkaline brines, and other solutions containing chlorine in some form.

**Organic Acids** Organic acids are much less corrosive than inorganic acids. This does not mean, however, that they can be taken lightly. For instance, acetic, lactic, formic, and



maleic acids all have their corrosive characteristics and must be treated accordingly when evaluating metallics and nonmetallics.

**Salt Solutions** Normally considered neutral, salt solutions do not present a serious corrosion problem. In some instances, process streams adjust pH to maintain a slightly alkaline environment, and such solutions are even less corrosive than when they are neutral. On the other hand, when a process stream has a pH adjustment to maintain a slightly acidic environment, the liquid becomes considerably more corrosive than neutral salt solutions. This condition requires that more effort be expended in evaluating the solution before making a material selection.

**Organic Compounds** Most organic compounds do not present corrosion problems of the same magnitude as inorganic compounds. This does not mean that any material arbitrarily selected will be a suitable choice. It does mean that there will be more materials available to choose from, but each application should be considered on its own merits. Of particular concern in this area are chlorinated organic compounds and those that will produce hydrochloric acid when moisture is present. Plastics, categorically, possess excellent corrosion resistance to inorganic compounds within their temperature limitations, but they do exhibit some weaknesses in their corrosion resistance to organic compounds.

**Water** Water is less corrosive than most of the other mediums encountered in the chemical and allied industries. For the term *water* to be meaningful, however, it is extremely important to know the specific kind of water: demineralized, fresh, brackish, salt, boiler feed, mine. These waters and the various constituents in them can demand a variety of materials, indicated, for example, by the spectrum of materials being studied and used in desalination programs. Because they are likely to have a very pronounced effect on our total economy, precise materials evaluation and selection are integral parts of these programs.

## **TYPES OF PUMP CORROSION**

---

The types of corrosion encountered in chemical pumps may at first appear to be unusual compared with those found in other process equipment. Nevertheless pumps, like any other type of chemical process equipment, experience basically only eight forms of corrosion, of which some are more predominant in pumps than in other types of equipment. It is not the intent here to describe in detail these eight forms of corrosion, but it is desirable to enumerate them and provide a brief description of each so they can be recognized when they occur.

**General, or Uniform, Corrosion** This is the most common type, and it is characterized by essentially the same rate of deterioration over the entire wetted or exposed surface. General corrosion may be very slow or very rapid, but it is of less concern than the other forms of corrosion because of its predictability. However, predicting the general corrosion rate in a pump can be a difficult task because of the varying velocities of the solution in the pump.

**Concentration Cell, or Crevice, Corrosion** This is a localized form of corrosion resulting from small quantities of stagnant solution in areas such as threads, gasket surfaces, holes, crevices, surface deposits, and the underside of bolt and rivet heads. When concentration cell corrosion occurs, the concentration of metal ions or oxygen in the stagnant area is different from the concentration in the main body of the liquid. This causes electric current to flow between the two areas, resulting in severe localized attack in the stagnant area.

**Pitting Corrosion** This is the most insidious form of corrosion, and it is very difficult to predict. It is extremely localized and manifested by small holes, and the weight loss

due to the pits will be only a small percentage of the total weight of the equipment. Chlorides in particular are notorious for inducing pitting. Pitting is common in areas other than stagnant areas, whereas concentration cell corrosion is basically confined to areas of stagnation.

**Stress Corrosion Cracking** This is localized failure caused by a combination of tensile stresses in a medium. Fortunately, castings, because of their basic overdesign, seldom experience stress corrosion cracking. Corrosion fatigue, which can be classified as stress corrosion cracking, is of concern in chemical pump shafts because of the repeated cyclic stressing. Failures of this type occur at stress levels below the yield point as a result of the cyclic application of the stress.

**Intergranular Corrosion** This is a selective form of corrosion at and adjacent to grain boundaries. It is associated primarily with stainless steels but can also occur with other alloy systems. In stainless steels, it occurs when the material is subjected to heat in the 800 to 1600°F (427 to 871°C) temperature range. Unless other alloy adjustments are made, this form of corrosion can be prevented only by heat-treating. It is easily detectable in castings because the grains are quite large relative to those in wrought material of equivalent composition. In some instances, uniform corrosion is misinterpreted as intergranular corrosion because of the etched appearance of the surfaces exposed to the environment. Even in ideally heat-treated stainless steels, very slight accelerated attack can be noticed at the grain boundaries because these areas are more reactive than the grains themselves. Care should be taken to avoid confusing general and intergranular corrosion. Stainless steel castings will never encounter intergranular corrosion if they are properly heat-treated after being exposed to temperatures in the 800 to 1600°F range (427 to 871°C).

**Galvanic Corrosion** This occurs when dissimilar metals are in contact or are otherwise electrically connected in a corrosive medium. Corrosion of the less noble metal is accelerated, and corrosion of the more corrosion-resistant metal is decreased. The farther apart the metals or alloys are in the electromotive series, the greater the possibility of galvanic corrosion. When it is necessary to have two dissimilar metals in contact, the total surface area of the less resistant metal should far exceed that of the more resistant material. This tends to prevent premature failure by simply providing a substantially greater area of the more corrosion-prone material. This form of corrosion is not common in chemical pumps but may be of some concern with accessory items in contact with pump parts and exposed to the environment.

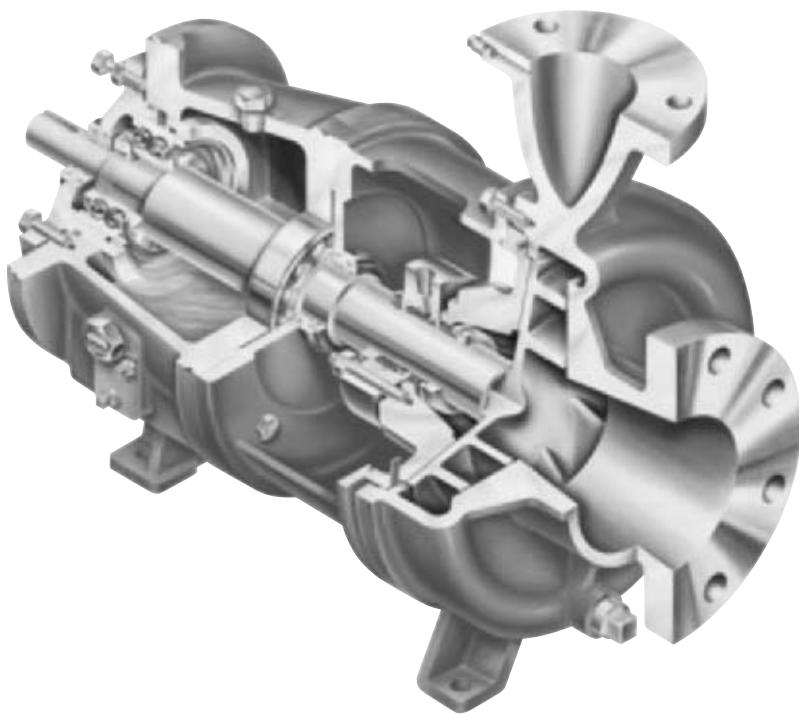
**Erosion-Corrosion** This type of failure is characterized by accelerated attack resulting from the combination of corrosion and mechanical wear. It may involve solids in suspension or high velocity. It is quite common with pumps where the erosive effects prevent the formation of a passive surface on alloys that require passivity to be corrosion-resistant. The ideal material for avoiding erosion-corrosion in pumps would possess the characteristics of corrosion resistance, strength, ductility, and extreme hardness. Few materials possess such a combination of properties.

**Selective Leaching Corrosion** This, in essence, involves removal of one element from a solid alloy in a corrosive medium. Specifically, it is typified by dezincification, dealuminification, and graphitization. This form of attack is not common in chemical pump applications because the alloys in which it occurs are not commonly used in heavy chemical applications.

## **TYPES OF CHEMICAL PUMPS**

---

The second step in selecting a chemical pump is to determine which type of pump is required, based on the characteristics of the liquid and on the desired head and flow rate.



**FIGURE 1** Cutaway of a typical centrifugal chemical pump (Flowserve Corporation)

It should also be noted that not all types are available in every material of construction, and the final selection of pump type may depend on the availability of designs in the proper material.

**Centrifugal Pumps** Centrifugal pumps (Figure 1) are used extensively in the chemical industry because of their suitability in practically any service. They are available in an almost unending array of corrosion-resistant materials. Although not built in extremely large sizes, pumps with capacity ranges of 5000 to 6000 gpm (1100 to 1400 m<sup>3</sup>/h) are commonplace. Heads range as high as 500 to 600 ft (150 to 180 m) at standard electric motor speeds. Centrifugal pumps are normally mounted in the horizontal position, but they may also be installed vertically, suspended in a tank, or hung in a pipeline similar to a valve. They are simple, economical, dependable, and efficient. Disadvantages include reduced performance when handling liquids of more than 500 SSU (108 cSt) viscosity and the tendency to lose prime when comparatively small amounts of air or vapor (3 to 5 percent) are present in the liquid.

**Rotary Pumps** The gear, screw, deforming-vane, sliding-vane, axial-piston, and cam types are used for high-pressure service. They are particularly adept at pumping liquids of high viscosity or low vapor pressure. Their constant displacement at a set speed makes them ideal for use in metering small quantities of liquid. Because they operate on the positive displacement principle, they are inherently self-priming. When built of materials that tend to gall or seize on rubbing contact, the clearances between mating parts must be increased, with the result of decreased efficiency. The gear, sliding-vane, and cam units are generally limited to use on clear, nonabrasive liquids.

**Diaphragm Pumps** These units are also classed as positive displacement sealless pumps because the diaphragm acts as a limited displacement piston. Pumping action is obtained when the diaphragm is forced into reciprocating motion by mechanical linkage, compressed air, or oil from a pulsating external source. This type of construction eliminates any connection between the liquid being pumped and the source of energy and thereby eliminates the possibility of leakage. This characteristic is of great importance when toxic or very expensive liquids are being handled. Disadvantages include a limited selection of corrosion-resistant materials, limited head and capacity range, and the necessity of using check valves in the suction and discharge nozzles. Although air-operated diaphragm pumps are displacement pumps, they are not positive displacement pumps. The maximum pumping pressure cannot exceed the pressure of the compressed air powering the pump. Refer to Section 3.6 for more details on diaphragm pumps.

**Regenerative Turbine Pumps** Flow rates up to 100 gpm (23 m<sup>3</sup>/h) and heads up to 700 ft (210 m) are easily handled with this type of pump. When it is used for chemical service, the internal clearances must be increased to prevent rubbing contact, which results in decreased efficiency. These pumps are generally unsuitable for solid-liquid mixtures of any concentration.

## CHEMICAL PUMP DESIGN CONSIDERATIONS

---

**Casting Integrity** Practically all the major components of chemical pumps are castings. There is probably more concern in chemical pump applications than in any other type of service because leakage, loss of product, and downtime can be extremely costly, as well as very dangerous.

**Mechanical Properties** There are several factors that determine whether a certain material can be utilized for a particular design. Materials may possess outstanding corrosion resistance but may be completely impossible to produce in the form of a chemical pump because of their limited mechanical properties. Accordingly, it is advisable to be aware of the mechanical properties of any material being considered in a corrosion evaluation program. Most materials are covered by ASTM or other specifications; such sources can be used for reference.

**Weldments** Welded construction should impose no limitation, provided the weldment is as good as or better than the base material. Materials requiring heat treatment to achieve maximum corrosion resistance must be treated after welding, or other adjustments must be made to make certain corrosion resistance is not sacrificed.

**Section Thickness** Pressure-containing parts are generally made thicker than required for handling a noncorrosive liquid so that full pumping capability will be maintained even after the loss of some material to the corrosive medium. Parts that are subject to corrosion from two or three sides, such as impellers, must be made considerably heavier than their counterparts in water or oil pumps. Pressure-containing parts are also made thicker so they will remain serviceable after a specified amount of corrosive deterioration. Areas subject to high velocities, such as the cutwater of a centrifugal pump casing, are reinforced to allow for the accelerated corrosion caused by the high velocities.

**Threads** Threaded construction of any type in the wetted parts must be avoided whenever possible. The thread form is subject to attack from two sides, and a small amount of corrosive deterioration can reduce the holding power of the threaded joint.

**Gaskets** Gasket materials must resist being corroded by the chemical being handled. Compressed synthetic fibers and elastomers have been used extensively for corrosion services. Fluorocarbon resins are used because of their almost complete corrosion resistance.

**Power End** This assembly, consisting of the bearing housing, bearings, oil or grease seals, and bearing lubrication system, is normally made of iron or steel components; thus it must be designed to withstand a severe chemical plant environment. For example, where venting of the bearing housing is required, special means of preventing the entrance of water, chemical fumes, or dirt must be incorporated into the vent design.

The bearing that controls axial shaft movement is usually selected to limit shaft movement to 0.002 in (0.051 mm) or less. Endplay values above this limit have been found detrimental to impeller and mechanical seal operation.

Water jacketing or fan cooling of the bearing housing may be necessary under certain conditions to maintain bearing temperatures below 180°F (82°C), the limit used in most applications.

**Maintenance** Maintenance of a chemical pump in a corrosive environment can be a very costly and time-consuming item. When evaluating materials and design factors, maintenance aspects should be high on the priority list. The ease and frequency of maintenance are critical items and should be considered part of a preventive maintenance program. Such a program can be the most effective way of eliminating emergency shutdowns caused by pump failure. Furthermore, the knowledge gained in a routine preventive maintenance program can be of unlimited value when a breakdown does occur because repair personnel will have acquired a thorough knowledge of the construction details of the pump.

## SEALING

---

The area around the sealing chamber probably causes more chemical pump failures than all other parts combined. The problem of establishing a seal between a rotating shaft and the stationary pump parts is one of the most intricate and vexing problems facing the pump designer.

**Packings** Braided fluorocarbon resins, aluminum, graphite, and many other materials or combinations of materials have been used to establish a seal (discussed in more detail in Subsection 2.2.2). A small amount of liquid must be allowed to seep through the packing to lubricate the surface between packing and shaft. This leakage rate is hard to control, and usually the packing is overtightened and the leakage is stopped. The unfortunate results of this condition is rapid scoring of the sealing surface, making it much harder to adjust the packing.

**Mechanical Seals** Mechanical shaft seals as described in Subsection 2.2.3 are used extensively on chemical pumps. The majority of chemical pumps in service today do not use packing. The primary consideration is selection of the proper materials for the type of corrosive liquid being pumped. Stainless steels, ceramics, graphite, and fluorocarbon resins are used to make most seal parts. Many seals consist of separate rotating and stationary elements that are assembled into the pump. However, cartridge seals are becoming more common, where the seal and gland are arranged in a unitized fashion with the seal for ease of assembly and adjustment that improve seal installation and operating life.

**Seal Chambers** Most chemical pumps are available with traditional convertible sealing chambers that can accept packing or mechanical seals. These “stuffing boxes” require narrow cross-section mechanical seals that are prone to early failure because of excessive temperature rise and trapped air. Chemical pumps are now available with oversized bore sealing chambers with additional liquid for cooling the seal and tapered bore sealing chambers with excellent seal cooling from fluid exchange with the pump and no trapped air, as they are self-venting.

**Temperature** One of the most important factors affecting the sealing medium is their operating temperature. Increased temperatures can result from high process temperatures and from heat generated by the sealing device. High temperature can increase the

corrosive attack on the sealing chamber, the packing or the mechanical seal. Seal parts not designed for high temperature can also distort or crack and fail.

One answer to the heat/temperature problem is to cool the sealing chamber with a water jacket that surrounds it and the seal gland. These jackets tend to be poor heat exchangers, however, and water can be expensive—or non-existent—in many locations. There is also the risk that the cooling water source will fail while the pump is running. These factors are contributing to the requirement that chemical pumps operating between 200° and 500°F (93° and 260°C) be selected with mechanical seals that can handle full process temperature. These pumps are then applied with oversized sealing chambers with product flush or tapered sealing chambers to maximize seal cooling and to avoid trapped air. In many cases, cooling water is no longer required.

**Pressure** Seal chamber pressure varies with suction or discharge pressure depending on its location in the pump and impeller design. Variations in impeller design include those using vertical or horizontal seal rings in combination with balance ports, or the use of back vanes, pump-out vanes, or pump-out slots. All impeller designs depend upon a close running clearance between the impeller and the stationary pump parts. This clearance must be kept as small as possible to prevent excessive recirculation of the liquid and the resulting loss of efficiency. Unfortunately, most chemical pump materials tend to seize when subjected to rubbing contact, and the running clearances must therefore be increased considerably above those used in pumps for other industries.

At pressures above 100 lb/in<sup>2</sup> (690 kPa), packing is generally unsatisfactory. Mechanical seals incorporating a balancing feature to relieve the high face pressure are the best means of sealing at pressures above 100 lb/in<sup>2</sup> (690 kPa).

**Shaft** Pump shaft bending—or deflection—can create additional sealing problems. Undersize shafts, or those made of materials that bend readily, will deflect from their true center in response to radial thrust on the impeller.

Mechanical seal operation is impaired when the shaft is bent or deflected during operation. Because the flexible member of the seal must adjust with each revolution of the shaft, excessive deflection results in shortened seal life. If the deflection is of more than nominal value, the flexible seal member will be unable to react with sufficient speed to keep the seal faces together, allowing leakage at the mating faces.

A limit of 0.002 in (0.05 mm) at the seal faces has been established as the maximum allowable shaft deflection consistent with good pump design and seal life. Operation of the pump outside the allowable operating flow region can also increase radial thrust and shaft deflection, shortening seal life.

**Shaft Surface** In the seal chamber region, the shaft surface must have corrosion resistance at least equal to and preferably better than that of the wetted parts of the pump. In addition, this surface must be hard enough to resist the tendency to wear under the packing or mechanical seal parts. Further, it must be capable of withstanding the sudden temperature changes often encountered in operation.

Often it is cost effective to make the shaft from high-strength carbon steel, and then add protective sleeve of stainless steel, plastic, carbon, glass, or a coating in the seal chamber area. Cylindrical sleeves are made so they can be removed and replaced when they become worn. Other designs utilize sleeves that are permanently bonded to the shaft. Where possible, shafts are increasingly being made from solid stainless steel to maximize the shaft diameter under the seal, reducing bending and increasing seal life. This is most effective when cartridge seals are used as they include their own sleeve.

Another method of obtaining a hard surface in this region is the welded overlay or spray coating of hard metals onto the base shaft. Ceramic materials applied by the plasma spray technique possess excellent corrosion resistance but cannot achieve the complete density required to protect the underlying shaft.

Composite shafts utilizing carbon steel for the power end and a higher alloy for the wet end have been used extensively where the high-alloy end has acceptable corrosion

resistance. The two ends are joined by various welding techniques, and the combination of metals is therefore limited to those that can be easily welded together. On such assemblies, the weld joint and the heat-affected zone must be outside the wetted area of the shaft.

**Sealless Pumps** Elimination of the sealing chamber and its associated problems has been the objective of several pump designs. Refer to Subsection 2.2.7 for sealless canned motor pumps and magnetically driven pumps. Diaphragm pumps previously mentioned are sealless pumps.

Vertical immersion pumps utilize sleeve bearings in the area immediately above the impeller to limit the flow of liquid along the shaft. For chemical service, the problem of materials associated with this bearing and its lubrication has to be addressed on an application basis.

## **CONSTRUCTION OF NONMETALLIC PUMPS**

---

A number of non-metallic materials have been used extensively in chemical pump construction (refer to Section 5.2). Their excellent chemical resistance makes them competitive with stronger metal alloys.

## **CHEMICAL PUMP STANDARDS**

---

In 1962, a committee of the Manufacturing Chemists Association (MCA) reached agreement with a special committee of the Hydraulic Institute on a proposed American Standards Association (ASA) standard for chemical process pumps. This document was referred to as the American Voluntary Standard or the Manufacturing Chemists Association Standard. In 1971, it was accepted by the American National Standards Institute (ANSI) and issued as ANSI Standard B123.1. This ANSI standard was renumbered in 1974 to ANSI B73.1, then to ANSI B73.1M in 1984.

It is the intent of this standard that pumps of similar size from all sources of supply shall be dimensionally interchangeable with respect to mounting dimensions, size and location of suction and discharge nozzles, input shafts, base plates, and foundation bolts. Table 1A and B lists the pump dimensions that have been standardized, and a cross-sectional assembly of a pump meeting these criteria is shown in Figure 1.

It is also the intent of this standard to outline certain design features that will minimize maintenance problems. The standard states, for instance, that the pump shaft should be sized so the maximum shaft deflection, measured at the centerline of the impeller when the pump is operating under its most adverse allowable conditions, will not exceed 0.005 in (0.127 mm). It does not specify shaft diameter because impeller diameter, shaft length, and provision for operation with liquids of high specific gravity would determine the proper diameter.

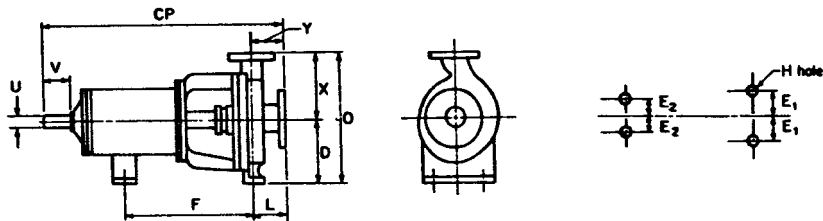
The standard also states that the minimum bearing life, again under the most adverse operating conditions within the allowable operating region, should be not less than two years. Bearing size is not specified but is to be determined by the individual manufacturer and will be dependent upon the load to be carried.

Additional specifications in the standard include hydrostatic test pressure, shaft finish at rubbing points, packing space, and seal chamber space.

ANSI B73.2M covers vertical in-line centrifugal pumps for chemical process. Dimensional criteria are shown in Table 2A and B, and a pump meeting these requirements is shown in Figure 2.

ANSI B73.5M-1995 is the Specification for Thermoplastic and Thermoset Polymer Material Horizontal End Suction Centrifugal Pumps for Chemical Process. A typical composite pump meeting these requirements is shown in Figure 3. Codes for acceptance tests are given in the American National Standard for Centrifugal Pump Tests, ANSI/HI 1.6-2000 (see References and Further Reading at the end of the section).





**TABLE 1A** Standard ANSI B73.1M dimensions in inches for horizontal pumps (Figure 1)

Dimension designation	Suction × discharge × nominal impeller diameter	CP	D	2E <sub>1</sub>	2E <sub>2</sub>	F	H	O	U		V, min.	X	Y
									Diameter	Keyway			
AA	1½ × 1 × 6	17½	5¼	6	0	7¼	5⁄8	11¾	7⁄8	3⁄16 × 3⁄32	2	6½	4
AB	3 × 2 × 6	17½	5¼	6	0	7¼	5⁄8	11¾	7⁄8	3⁄16 × 3⁄32	2	6½	4
AC	3 × 2 × 6	17½	5¼	6	0	7¼	5⁄8	11¾	7⁄8	3⁄16 × 3⁄32	2	6½	4
AB	3 × 1½ × 8	17½	5¼	6	0	7¼	5⁄8	11¾	7⁄8	3⁄16 × 3⁄32	2	6½	4
A10	3 × 2 × 6	23½	8¼	9¾	7¼	12½	5⁄8	16½	1⅛	¼ × 1⁄8	2⅝	8¼	4
AA	1½ × 1 × 8	17½	5¼	6	0	7¼	5⁄8	11¾	7⁄8	3⁄16 × 3⁄32	2	6½	4
A50	3 × 1½ × 8	23½	8¼	9¾	7¼	12½	5⁄8	16¾	1⅛	¼ × 1⁄8	2⅝	8½	4
A60	3 × 2 × 8	23½	8¼	9¾	7¼	12½	5⁄8	17¾	1⅛	¼ × 1⁄8	2⅝	9½	4
A70	4 × 3 × 8	23½	8¼	9¾	7¼	12½	5⁄8	19¼	1⅛	¼ × 1⁄8	2⅝	11	4
A05	2 × 1 × 10	23½	8¼	9¾	7¼	12½	5⁄8	16¾	1⅛	¼ × 1⁄8	2⅝	8½	4
A50	3 × 1½ × 10	23½	8¼	9¾	7¼	12½	5⁄8	16¾	1⅛	¼ × 1⁄8	2⅝	8½	4
A60	3 × 2 × 10	23½	8¼	9¾	7¼	12½	5⁄8	17¾	1⅛	¼ × 1⁄8	2⅝	9½	4
A70	4 × 3 × 10	23½	8¼	9¾	7¼	12½	5⁄8	19¼	1⅛	¼ × 1⁄8	2⅝	11	4

(continues)



**TABLE 1A** Continued.

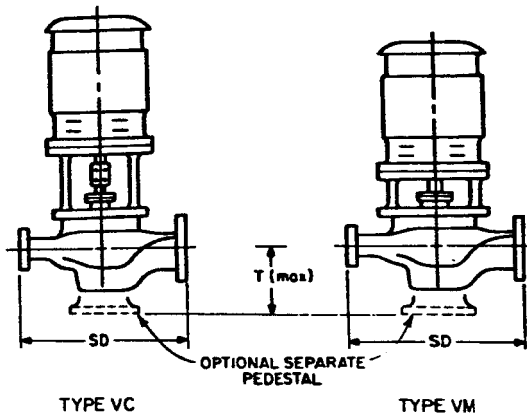
Dimension designation	Suction × discharge × nominal impeller diameter	$CP$	$D$	$2E_1$	$2E_2$	$F$	$H$	$O$	$U$		$V$ , min.	$X$	$Y$
									Diameter	Keyway			
A40	$4 \times 3 \times 10$	$23\frac{1}{2}$	10	$9\frac{3}{4}$	$7\frac{1}{4}$	$12\frac{1}{2}$	$\frac{5}{8}$	$22\frac{1}{2}$	$\frac{1}{8}$	$\frac{1}{4} \times \frac{1}{8}$	$2\frac{5}{8}$	$12\frac{1}{2}$	4
A20	$3 \times 1\frac{1}{2} \times 13$	$23\frac{1}{2}$	10	$9\frac{3}{4}$	$7\frac{1}{4}$	$12\frac{1}{2}$	$\frac{5}{8}$	$20\frac{1}{2}$	$\frac{1}{8}$	$\frac{1}{4} \times \frac{1}{8}$	$2\frac{5}{8}$	$10\frac{1}{2}$	4
A30	$3 \times 2 \times 13$	$23\frac{1}{2}$	10	$9\frac{3}{4}$	$7\frac{1}{4}$	$12\frac{1}{2}$	$\frac{5}{8}$	$21\frac{1}{2}$	$\frac{1}{8}$	$\frac{1}{4} \times \frac{1}{8}$	$2\frac{5}{8}$	$11\frac{1}{2}$	4
A40	$4 \times 3 \times 13$	$23\frac{1}{2}$	10	$9\frac{3}{4}$	$7\frac{1}{4}$	$12\frac{1}{2}$	$\frac{5}{8}$	$22\frac{1}{2}$	$\frac{1}{8}$	$\frac{1}{4} \times \frac{1}{8}$	$2\frac{5}{8}$	$12\frac{1}{2}$	4
A80 <sup>a</sup>	$6 \times 4 \times 13$	$23\frac{1}{2}$	10	$9\frac{3}{4}$	$7\frac{1}{4}$	$12\frac{1}{2}$	$\frac{5}{8}$	$23\frac{1}{2}$	$\frac{1}{8}$	$\frac{1}{4} \times \frac{1}{8}$	$2\frac{5}{8}$	$13\frac{1}{2}$	4
A90 <sup>a</sup>	$8 \times 6 \times 13$	$33\frac{7}{8}$	$14\frac{1}{2}$	16	9	$18\frac{3}{4}$	$\frac{7}{8}$	$30\frac{1}{2}$	$2\frac{3}{8}$	$\frac{5}{8} \times \frac{5}{16}$	4	16	6
A100 <sup>a</sup>	$10 \times 8 \times 13$	$33\frac{7}{8}$	$14\frac{1}{2}$	16	9	$18\frac{3}{4}$	$\frac{7}{8}$	$32\frac{1}{2}$	$2\frac{3}{8}$	$\frac{5}{8} \times \frac{5}{16}$	4	18	6
A105	$6 \times 4 \times 15$	$33\frac{7}{8}$	$14\frac{1}{2}$	16	9	$18\frac{3}{4}$	$\frac{7}{8}$	$30\frac{1}{2}$	$2\frac{3}{8}$	$\frac{5}{8} \times \frac{5}{16}$	4	16	6
A110 <sup>a</sup>	$8 \times 6 \times 15$	$33\frac{7}{8}$	$14\frac{1}{2}$	16	9	$18\frac{3}{4}$	$\frac{7}{8}$	$33\frac{1}{2}$	$2\frac{3}{8}$	$\frac{5}{8} \times \frac{5}{16}$	4	18	6
A120 <sup>a</sup>	$10 \times 8 \times 15$	$33\frac{7}{8}$	$14\frac{1}{2}$	16	9	$18\frac{3}{4}$	$\frac{7}{8}$	$33\frac{1}{2}$	$2\frac{3}{8}$	$\frac{5}{8} \times \frac{5}{16}$	4	19	6
A125	$6 \times 4 \times 17$	$33\frac{7}{8}$	$14\frac{1}{2}$	16	9	$18\frac{3}{4}$	$\frac{7}{8}$	$30\frac{1}{2}$	$2\frac{3}{8}$	$\frac{5}{8} \times \frac{5}{16}$	4	16	6
A110	$8 \times 6 \times 17$	$33\frac{7}{8}$	$14\frac{1}{2}$	16	9	$18\frac{3}{4}$	$\frac{7}{8}$	$32\frac{1}{2}$	$2\frac{3}{8}$	$\frac{5}{8} \times \frac{5}{16}$	4	18	6
A120	$10 \times 8 \times 17$	$33\frac{7}{8}$	$14\frac{1}{2}$	16	9	$18\frac{3}{4}$	$\frac{7}{8}$	$33\frac{1}{2}$	$2\frac{3}{8}$	$\frac{5}{8} \times \frac{5}{16}$	4	19	6

<sup>a</sup>Suction connections may have tapped bolt holes.

**TABLE 1B** Standard ANSI B73.1M dimensions in millimeters for horizontal pumps (Figure 1)

Dimension designation	Suction × discharge × nominal impeller diameter	$CP^b$	$D$	$2E_1$	$2E_2$	$F$	$H$	$O$	$U$		$V_f$ , min.	$X$	$Y$
									Diameter	Keyway			
AA	40 × 25 × 150	445	133	152	0	184	16	298	22.23	4.76 × 2.38	51	165	102
AB	80 × 50 × 150	445	133	152	0	184	16	298	22.23	4.76 × 2.38	51	165	102
AC	80 × 50 × 150	445	133	152	0	184	16	298	22.23	4.76 × 2.38	51	165	102
AB	80 × 40 × 200	445	133	152	0	184	16	298	22.23	4.76 × 2.38	51	165	102
A10	80 × 50 × 150	597	210	248	184	318	16	420	28.58	6.35 × 3.18	67	210	102
AA	40 × 25 × 200	445	133	152	0	194	16	298	22.23	4.76 × 2.38	51	165	102
A50	80 × 40 × 200	597	210	248	184	318	16	425	28.58	6.35 × 3.18	67	216	102
A60	80 × 50 × 200	597	210	248	184	318	16	450	28.58	6.35 × 3.18	67	242	102
A70	100 × 80 × 200	597	210	248	184	318	16	490	28.58	6.35 × 3.18	67	280	102
A05	50 × 25 × 250	597	210	248	184	318	16	425	28.58	6.35 × 3.18	67	216	102
A50	80 × 40 × 250	597	210	248	184	318	16	425	28.58	6.35 × 3.18	67	216	102
A60	80 × 50 × 250	597	210	248	184	318	16	450	28.58	6.35 × 3.18	67	216	102
A70	100 × 80 × 250	597	210	248	184	318	16	490	28.58	6.35 × 3.18	67	280	102
A40	100 × 80 × 250	597	254	248	184	318	16	572	28.58	6.35 × 3.18	67	318	102
A20	80 × 40 × 330	597	254	248	184	318	16	520	28.58	6.35 × 3.18	67	266	102
A30	80 × 50 × 330	597	254	248	184	318	16	520	28.58	6.35 × 3.18	67	266	102
A40	100 × 80 × 330	597	254	248	184	318	16	572	28.58	6.35 × 3.18	67	318	102
A80 <sup>a</sup>	150 × 100 × 330	597	254	248	184	318	16	597	28.58	6.35 × 3.18	67	343	102
A90 <sup>a</sup>	200 × 150 × 330	860	368	406	229	476	22	775	60.33	15.88 × 7.94	102	406	152
A100 <sup>a</sup>	250 × 200 × 330	860	368	406	229	476	22	826	60.33	15.88 × 7.94	102	457	152
A105	150 × 100 × 380	860	368	406	229	476	22	775	60.33	15.88 × 7.94	102	406	152
A110 <sup>a</sup>	200 × 150 × 380	860	368	406	229	476	22	826	60.33	15.88 × 7.94	102	457	152
A120 <sup>a</sup>	250 × 200 × 380	860	368	406	229	476	22	851	60.33	15.88 × 7.94	102	483	152
A125	150 × 100 × 425	860	368	406	229	476	22	775	60.33	15.88 × 7.94	102	406	152
A110	200 × 150 × 425	860	368	406	229	476	22	826	60.33	15.88 × 7.94	102	457	152
A120	250 × 200 × 425	860	368	406	229	476	22	851	60.33	15.88 × 7.94	102	483	152

<sup>a</sup>Suction connections may have tapped bolt holes.<sup>b</sup>See Table 1A for dimensional symbols.



**TABLE 2A** Standard ANSI B73.2M dimensions for vertical inline pumps—USCS units

Pump designation VC (or VM) <sup>a</sup>	ANSI 125, 150, 250, or 300 flange size, in		SD (+10, -0.08), in	T (max), in
	Suction	Discharge		
2015/15	2	1½	14.96	
2015/17	2	1½	16.93	6.89
2015/19	2	1½	18.90	
3015/15	3	1½	14.96	
3015/19	3	1½	18.90	7.87
3015/24	3	1½	24.02	
3020/17	3	2	16.93	
3020/20	3	2	20.08	7.87
3020/24	3	2	24.02	
4030/22	4	3	22.05	
4030/25	4	3	25.00	8.86
4030/28	4	3	27.95	
6040/24	6	4	24.02	
6040/28	6	4	27.95	9.84
6040/30	6	4	29.92	

<sup>a</sup>Sequence defines design, suction flange size, discharge flange size and SD dimension

**TABLE 2B** Standard ANSI B73.2M dimensions for vertical inline pumps—SI units

Pump designation <sup>a</sup> , VC (or VM)	Flange Size, mm		SD <sup>b</sup> (+2.5, −2.0), mm	T (max), mm
	Suction	Discharge		
50-40-380	50	40	380	175
50-40-430	50	40	430	175
50-40-480	50	40	480	175
80-40-380	80	40	380	200
80-40-480	80	40	480	200
80-40-610	80	40	610	200
80-50-430	80	50	430	200
80-50-510	80	50	510	200
80-50-610	80	50	610	200
100-80-560	100	80	560	225
100-80-635	100	80	635	225
100-80-710	100	80	710	225
150-100-610	150	100	610	250
150-100-710	150	100	710	250
150-100-760	150	100	760	250

<sup>a</sup>Sequence defines design, suction flange size, discharge flange size, and SD dimension

<sup>b</sup>See Table 2A for dimensional symbols.

Other global dimensional standards for both horizontal and vertical pumps are also used. In 1971, the International Organization for Standardization (ISO) reached agreement on a set of dimensional standards for horizontal end-suction centrifugal pumps. This document, ISO 2858, in SI units, describes a series of pumps of slightly lower capacity than described in ANSI B73.1. Technical specifications are covered in ISO 5199. Codes for acceptance tests are given in ISO 2548 and ISO 3555.



**FIGURE 2** Vertical in-line centrifugal pump for chemical process applications (Flowserve Corporation)

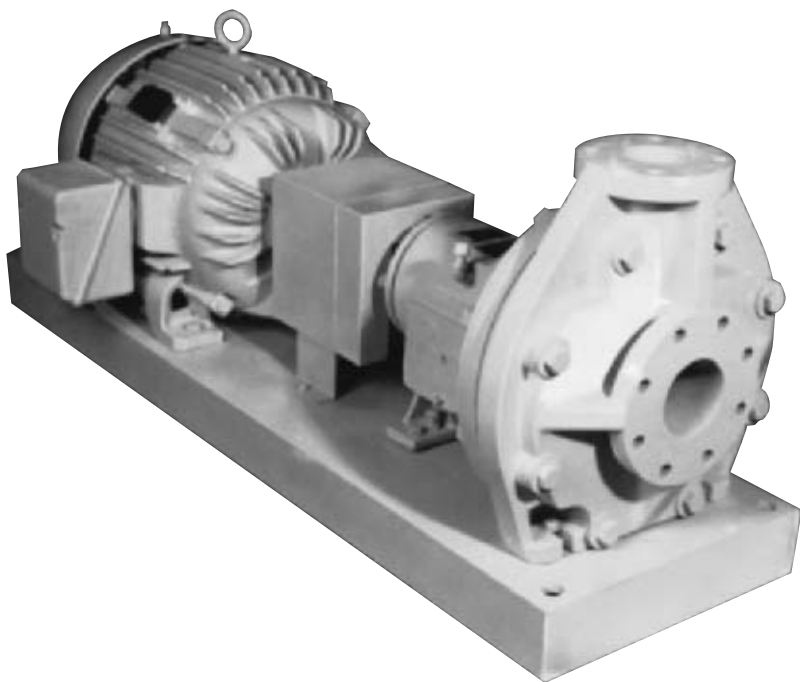


FIGURE 3 A typical composite pump (Flowsolve Corporation)

## REFERENCES AND FURTHER READING

---

- Fontana, M. G., and Greene, N. D. *Corrosion Engineering*. McGraw-Hill, New York, 1978.
- American National Standards for Centrifugal Pump Tests, ANSI/HI 1.6-2000, Hydraulic Institute, Parsippany, NJ [www.pumps.org](http://www.pumps.org).
- Specifications for Centrifugal Pumps for Chemical Process: ANSI/ASME B73.1M—1991, Horizontal End Suction; ANSI/ASME B73.2M—1991, Vertical In-line; ANSI/ASME B73.5—1995, Polymer Materials; American Society of Mechanical Engineers, New York, NY [www.asme.org](http://www.asme.org).
- Lee, J. A. *Materials of Construction for Chemical Process Industries*. McGraw-Hill, New York, 1950.
- National Association of Corrosion Engineers. *Corrosion Data Survey*. NACE, Houston, 1967.
- National Association of Corrosion Engineers. *Proceedings, Short Course on Process Industry Corrosion*. NACE, Houston, 1960.

---

# SECTION 9.7

---

# PETROLEUM INDUSTRY

---

R. L. JONES  
A. W. ELVITSKY  
C. C. HEALD

## **USE OF PUMPS**

---

Pumps of all types are used in every phase of petroleum production, transportation, and refining.

Production pumps include reciprocating units for mud circulation during drilling and sucker-rod, hydraulic rodless, and motor driven submersible centrifugal units for lifting crude to the surface. The most common use of centrifugal pumps in production is for water flooding (secondary recovery, subsidence prevention, or pressure maintenance).

Transportation pumps include units for gathering, for on and offshore production, for pipelining crude and refined products, for loading and unloading tankers, tank cars, barges, or tank trucks, and for servicing airport fueling terminals. The majority of the units are centrifugal.

Refining units vary from single stage centrifugal units to horizontal and vertical multistage barrel type pumps handling a variety of products over a full range of temperatures and pressures. Centrifugal pumps are also used for auxiliary services, such as cooling towers and cooling water.

Except for some comments about the use of displacement pumps for handling viscous liquids, this section is restricted to centrifugal pumps, the type most frequently used in the petroleum industry. It also includes an overview of the requirements for some of the principal types of centrifugal pumps.

## **REFINERY PUMPS**

---

Major refinery processes are crude distillation, vacuum tower separation, catalytic conversion, alkylation, hydrocracking, catalytic reforming, coking, and hydrotreatment for the removal of sulfur and nitrogen. The products resulting from these processes include motor

gasoline, commercial jet fuel and kerosene, distillate fuel oil, residual fuel oil and lubricating oils. The American Petroleum Institute Standard 610, "Centrifugal Pumps for Petroleum, Heavy Duty Chemical, and Gas Industry Services" (API 610), has established specifications for the design features required for centrifugal pumps used for general refinery service. The standard also includes guidance with respect to lighter duty, non-flammable/nonhazardous services where the requirements of API 610 may not be required.

API 610 first edition was published in October of 1954. In its initial form, the document contained only 15 pages of text and applied to single stage overhung pumps only. Since the original publication, the standard has been updated on a regular basis, approximately every five to six years. In the eighth edition, it now contains 60 pages of text, 146 pages of appendices, and covers the specification of as many as 18 different pump types. The eighth edition, for the first time, shows a "family tree" (Figure 1) of pump types that are potentially covered, and a document organization that makes it clear which requirements apply to what pumps.

**Construction** Figure 2 illustrates the details of a single-stage overhung refinery process pump meeting API 610 requirements. Such a pump is referred to as a Type OH2. The suction nozzle may be located either at the end or at the top. A spacer coupling is used between the pump shaft and the driver shaft so the bearing bracket and cover may be removed without disconnecting the suction or discharge piping. This is referred to as a back pull-out design. Figure 3 illustrates the details of a between bearings, two-stage, radially split pump of type BB2. Type BB2 pumps can have one or two stages. Figures 4 and 5 show horizontal multistage pumps. Figure 4 is an axially split machine, Type BB3, and Figure 5 is a radially split or barrel-type pump, Type BB5. It is a requirement of all present day horizontal refinery pumps that the mechanical seal can be changed and the rotor removed without disconnecting the piping or moving the driver.

API 610 requires standardized seal chamber dimensions for all pumps. For overhung designs, there is only one seal chamber to seal against leakage to the atmosphere. For between bearings designs, there are two seal chambers. In single stage overhung pumps, the seal chamber pressure during pump operation is between suction and discharge pressure, depending on the design of the wear rings and impeller balance holes. For between bearings pumps, a leak off or balance line system is usually included so both seal chambers operate at the same pressure. That pressure is usually suction pressure. Although most refiners strongly prefer single seals for cost and reliability reasons, environmental requirements increasingly drive them toward dual seals. In either case, for each seal, one of the sealing rings is made of carbon, and the mating ring is either silicon carbide or tungsten carbide. API 610 gives standardized auxiliary piping plans for the support of all liquid-type mechanical seals and requires that seals meet requirements of API Standard 682, "Shaft Sealing Systems for Centrifugal and Rotary Pumps" (API 682). Mechanical seals have proved extremely reliable and virtually no new pumps are supplied with packing for process services.

The thrust bearing for single stage overhung pumps is subject to axial loading caused by exposure of one end of the shaft to suction pressure and forces on the impeller due to the differential between suction pressure and discharge pressure. When single stage overhung pumps are used for suction pressures in excess of 250 psig (17 MPa), it is common practice to "unbalance" the impeller wear rings. This is done by making the diameter of the back wear rings smaller than that of the suction side wear rings, or by eliminating the back wear rings completely. This produces an unbalanced axial thrust load in the opposite direction to that created by high suction pressure and, thus, decreases the net axial load on the thrust bearing. In the case of multistage pumps, the differential pressure across the impellers builds with each stage and some method must be employed to reduce the load on the thrust bearing. In some designs, axial thrust is balanced by means of a balance piston/leak-off arrangement; in others, an opposed impeller arrangement helps to balance axial loads. In all cases, to meet API 610 requirements, the bearings must be designed for a minimum life of 25,000 hours of continuous operation at rated conditions and 16,000 hours at maximum radial and axial loads, at rated speed.



# CENTRIFUGAL PUMP TYPES

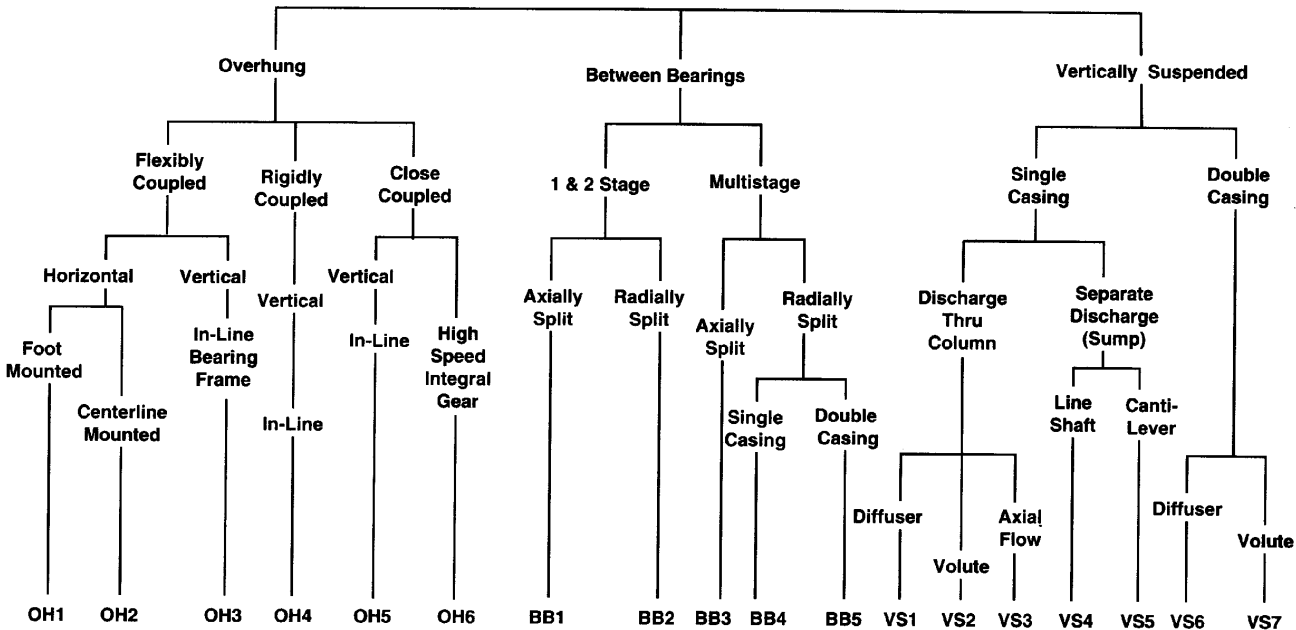
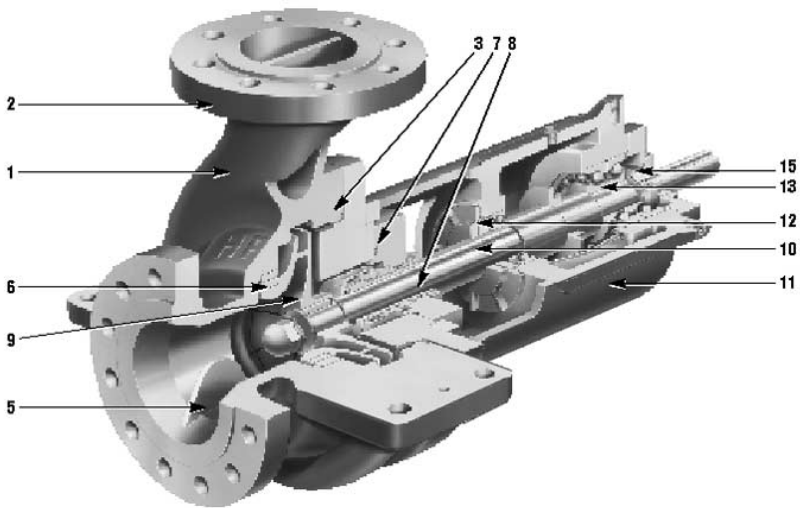


FIGURE 1 Pump classification type identification (Courtesy of the American Petroleum Institute<sup>1</sup>)

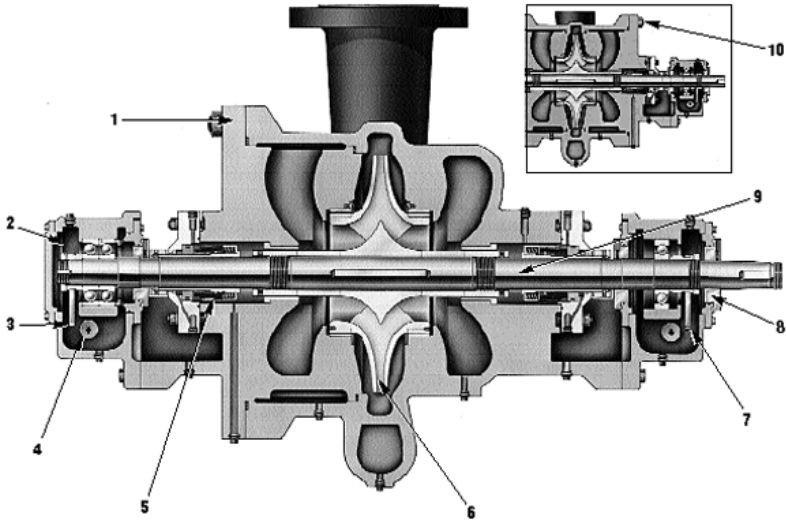


**FIGURE 2** Single stage overhung refinery process pump—API 610 Type OH2. (1) Pump casing, (2) Discharge flange; flanges are standard ANSI B16.5 Class 300, (3) Metal-to-metal casing joint with fully confined, controlled compression gasket, (4) Casing drain at bottom of volute (not shown), (5) Suction nozzle guide vane (featured on some models), (6) Renewable casing and impeller wear rings, (7) Seal chamber with minimum standard dimensions, (8) Cartridge mechanical seal, (9) Impeller—dynamically balanced, (10) Shaft—heavy duty to minimize deflection, (11) Bearing housing, (12) Finned bearing housing cover for air circulation and cooling, (13) Single-row radial and back-to-back mounted angular contact thrust bearings are standard, (15) Labyrinth-type bearing housing closures on both ends, (Flowsolve Corporation)

Where casting limitations permit, double volute pumps are used to limit the radial load imposed on the impeller by uneven pressure distributions in the casing. To comply with API 610, the shaft deflection at the wear rings for one and two stage pumps, under most severe dynamic conditions, must be limited to one half the minimum diametrical (internal) clearance specified (the design clearance). For operating temperatures above 500°F (260°C), or where the pump wear rings are made of materials with higher galling tendencies, API 610 requires that 0.005 in. (0.13 mm) be added to the minimum specified diametrical clearances. Whenever hardenable wear ring materials are used, the mating wear rings are required to have a differential hardness of at least 50 BHN (Brinell Hardness Number) unless both rings are harder than 400 BHN. This requirement is to minimize the chances of the mating wear rings galling and seizing together if contact occurs.

To aid in maintaining alignment at various operating temperatures, pump mounting feet are located on the case at the same centerline as the shaft for all horizontal pumps. Earlier editions of API 610 also suggested using bearing or seal chamber cooling at elevated pumping temperatures. However, the industry has moved toward less and less cooling water usage because of cost and availability of quality water sources in many areas. Currently, API 610 leaves cooling as an item to be jointly agreed upon by the purchaser and the pump vendor.

In general, pumps meeting API 610 are designed for operation at elevated temperatures. In all services, but particularly in high temperature services, pumps are subject to loads at the nozzles due to thermal movements of piping, fabrication errors in the piping, and movements of the piping supports. These forces and moments tend to “move” the pump relative to its driver and result in misalignment of the pump and driver shafts. This misalignment can increase vibration levels and impose forces on the shafting that contribute to poor reliability. API 610 prescribes minimum forces and moments, by nozzle size, that complying

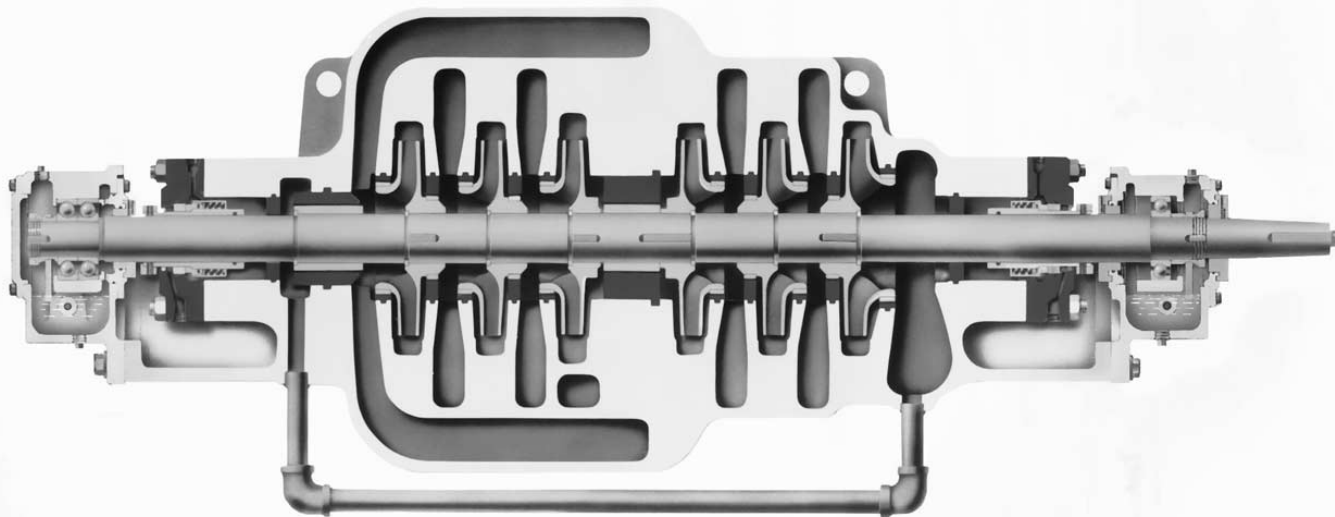


**FIGURE 3** Between bearings, single stage, double section radially split pump—API 610 Type BB2. (1) Pump casing and cover with metal-to-metal confined gasketed joint, (2) Thrust bearing housing with back-to-back angular contact ball bearings, (3) Oil ring lubrication, (4) Cooling insert, (5) Seal chamber and cartridge mechanical seal, (6) Double suction impeller, dynamically balanced, (7) Radial bearing housing with deep-groove radial ball bearing and oil ring lubrication, (8) Labyrinth-type flingers at all bearing housing—shaft openings, (9) Heavy duty shaft to limit deflection at the seals and impeller, (10) Double cover design on some models. (Flowserve Corporation)

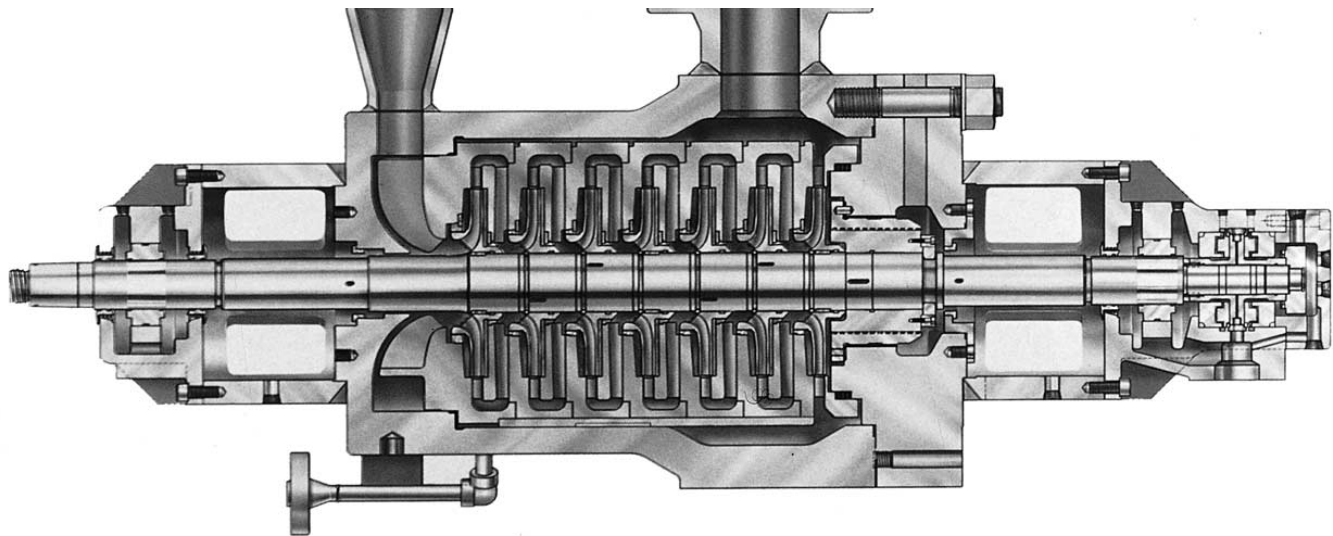
pumps must be able to withstand. Further, it outlines a test procedure to allow verification that a pump meets these minimum nozzle load requirements. The coordinate system for orientation of nozzle loads is in accordance with ISO 1503 standard convention.

Inline pumps have been developed, in part, to avoid the problem of misalignment due to nozzle loads. Figure 6 shows a single stage, overhung, inline pump with a separate bearing frame, Type OH3. Figure 7 shows a high-speed integrally geared inline pump, Type OH6. For a given flange size, inline pumps are required to withstand twice the magnitude of nozzle loads allowed for horizontal pumps. In addition, installation is simplified and less expensive because a block foundation is not required, and the pump mounts in a pipeline similar to a valve, although most users supply a support of some kind for the pump. Furthermore, the vertical arrangement causes the pump to take up much less space. The Type OH6 pump (Figure 7) has a gear box that increases the speed at which the impeller spins and typically produces high heads at relatively low flows. This type of design has many advantages in certain low flow, high head services. Some alternative inline pump designs utilize high-speed motors that eliminate the need for the gearbox. High-speed pumps may also be supplied with inducers in front of the typically radially bladed impellers to improve suction (*NPSH*) performance. When this is done, the range of operation of the pump may be restricted to avoid off-design flow instability. This should be recognized and the required range of pump operation should be addressed during the applications stage of pump selection.

Pumps of overhung shaft construction are nominally limited by most manufacturers to drivers rated below 500 hp (375 kW). Units with greater power requirements are usually designed with bearings on both ends of the shaft and the impeller—or impellers—in between the bearings (designated by API 610 as between bearings, or Type BB, pumps). Ball bearing construction, in compliance with requirements of API 610, is used to a limit of a bearing  $Nd_m$  factor of 500,000. The  $Nd_m$  factor is the product of the pump operating speed ( $N$ ), in revolutions per minute and the mean bearing diameter ( $d_m$ ), equal to the bearing bore plus the bearing outside diameter, divided by 2 (all dimensions in millimeters). For values of  $Nd_m$  above 500,000, or where the bearing basic life rating ( $L_{10h}$ ) does not meet the



**FIGURE 4** Axially split multistage pump API 610 Type BB3 (Flowsolve Corporation)



**FIGURE 5** Radially split or barrel type pump—API 610 Type BB5 (Flowserve Corporation)



**FIGURE 6** Single stage, overhung, vertical inline pump with separate bearing frame—API 610 Type OH3 (Flowserve Corporation)

minimum life requirements mentioned earlier, hydrodynamic bearings are required. This may result in a pump with sleeve radial and rolling element thrust bearings, or with both hydrodynamic radial and thrust bearings. API 610 also establishes an energy density limit of four million, above which hydrodynamic radial and thrust bearings are always required.

To ensure safety and reliability, it is an API 610 requirement that pump pressure casings and flanges be designed for maximum pump discharge pressure plus allowances for head increases at the rated pumping temperatures. API 610 also establishes minimum pressure ratings for all covered pumps. For horizontal radially split pumps, the minimum

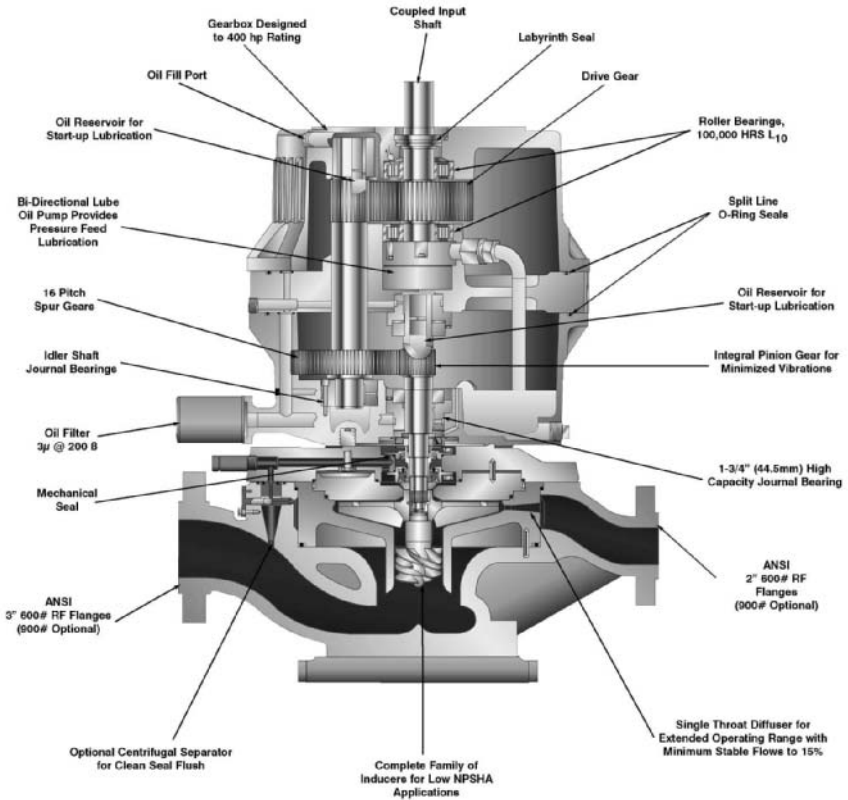


FIGURE 7 Integrally geared inline pump—API 610 Type OH6 (Sundyne Corporation)

pump pressure rating is that of an ANSI/ASME B16.5 Class 300 (ISO 7005-1 PN50) steel flange of the material grade corresponding to that of the casing, or 600 psig (4 MPa), whichever is less. Furthermore, all pumps are subjected to a hydrostatic test at 1.5 times the case rating. It is a requirement for one- and two-stage pumps that the suction and discharge flanges have the same pressure rating and that the casing have a minimum pressure rating equivalent to the flange rating.

**Performance** Figure 8 illustrates the wide range of capacity and head requirements that can be met by one- and two-stage refinery pumps. The range shown varies slightly with the manufacturer. The range of inline pumps is almost identical to that of horizontal overhung units. Multistage centrifugal units are available for extremely large flows and heads.

API 610 requires a performance test in accordance with Hydraulic Institute standards for all pumps. The only deviation from Hydraulic Institute (HI) standards is that efficiency is calculated for information and is not a rating or guarantee value. Power is the guarantee quantity and includes all losses (such as for mechanical seals and bearings). Vibration levels are taken during the test and acceptance criteria are established for both bearing housing and shaft measurements on the pump manufacturer's test stand. In general, refiners have lowered vibration levels in their plants through conscientious maintenance

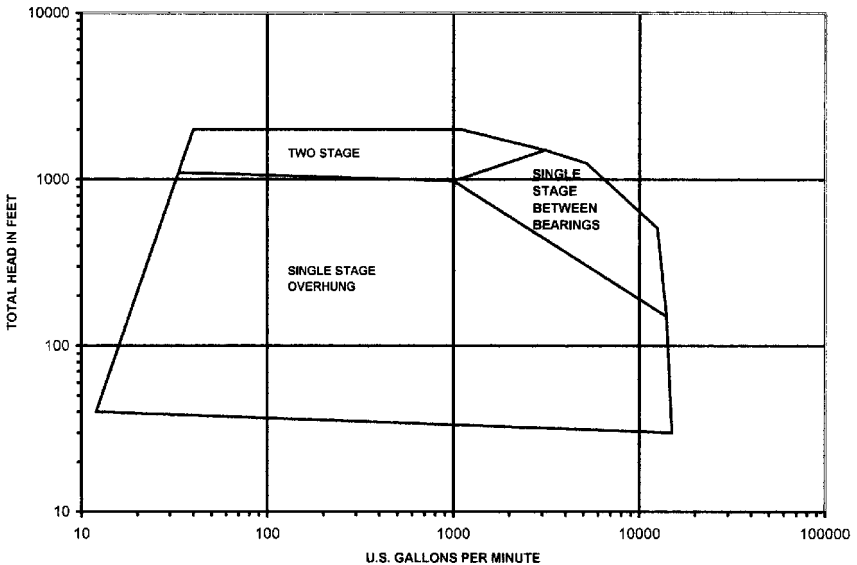


FIGURE 8 Performance coverage for single stage and two-stage refinery pumps.  
(U.S. gpm  $\times$  0.227 = m<sup>3</sup>/h; ft  $\times$  0.305 = m)

practices, particularly in the areas of balance and alignment. The API vibration acceptance criteria are somewhat more liberal than typical plant values because of the temporary nature of a manufacturer's performance test setup. If critical service suction conditions warrant it, an NPSH test may also be conducted.

**Materials** Refinery pumps handle a variety of products with specific gravities ranging from 0.3 to 1.3 and viscosities from values below that of water to as high as 15,000 SSU (3240 centistokes) for centrifugal pumps and even higher for rotary pumps, over a wide range of temperatures. The product may be as inert as a lubricating-type oil or extremely corrosive. Many materials are utilized to satisfy these varied product requirements; the most common material classes are given in Table 1 (API 610 Table G-1: Material Class Selection Guide). Material classes and specifications are given in Table 2 (API 610 Table H-1: Materials for Pump Parts).

**Drivers** Drivers for refinery pumps are usually either electric motors or steam turbines. Centrifugal pumps running backward as hydraulic turbines are also used. The vast majority of refinery pumps are run at a fixed, 2-pole speed of either 3600 rpm in 60 cycle locations or 3000 rpm in 50 cycle locations.

## PIPELINE PUMPS

Centrifugal pumps are used on every major liquid pipeline in the world to transport a variety of fluids, including crude oil, motor gasoline, fuel oil, jet fuel, liquefied petroleum gases, and anhydrous ammonia. Pump efficiency is of primary importance because of the power required to transport the liquid. Most pipeline systems install pumps in series because the differential head requirement is primarily energy loss due to friction, and an outage of one of the units would result in only a partial loss in the throughput capacity. For pipelines



TABLE 1 Material class selection guide (Courtesy of the American Petroleum Institute)<sup>a</sup>

Service	Temperature Range		Pressure Range	Material Class	See Reference Note
	°C	°F			
Fresh water, condensate, cooling tower water	<100	<212	All	I-1 or I-2	
Boiling water and process water	<120	<250	All	I-1 or I-2	5
	120-175	250-350	All	S-5	5
	>175	>350	All	C-6	5
Boiler feed water	>95	>200	All	C-6	
	>95	>200	All	S-6	
Boiler circulator	>95	>200	All	C-6	
Foul water, reflux drum water, water draw, and hydrocarbons containing these waters, including reflux streams	<175	<350	All	S-3 or S-6	6
	>175	>350	All	C-6	
Propane, butane, liquefied petroleum gas, and ammonia (NH <sub>3</sub> )	<230	<450	All	S-1	
Diesel oil; gasoline; naphtha; kerosene; gas oils; light, medium, and heavy lube oils; fuel oil; residuum; crude oil; asphalt; synthetic crude bottoms	<230	<450	All	S-1	
	230-370	450-700	All	S-6	6, 7
	>370	>700	All	C-6	6
Noncorrosive hydrocarbons, e.g., catalytic reformat, isomaxate, desulfurized oils	230-370	450-700	All	S-4	7
Xylene, toluene, acetone, benzene, furfural, MEK, cumene	<230	<450	All	S-1	
Sodium carbonate, doctor solution	<175	<350	All	I-1	
Caustic (sodium hydroxide) concentration of ≤20%	<100	<210	All	S-1	8
	≥100	≥200	All	—	9
	>95	>200	All	—	10
Seawater	<260	<470	All	D-1	
Sour water	All	All	All	S-1	
Sulfur (liquid state)	All	All	All	S-1	
FCC slurry	<370	<700	All	C-6	
Potassium carbonate	<175	<350	All	C-6	
	<370	<700	All	A-8	
MEA, DEA, TEA-stock solutions	<120	<250	All	S-1	
DEA, TEA-lean solutions	<120	<250	All	S-1	8
MEA-lean solution (CO <sub>2</sub> only)	80-150	175-300	All	S-9	8
MEA-lean solution (CO <sub>2</sub> and H <sub>2</sub> S)	80-150	175-300	All	—	8, 11
MEA, DEA, TEA, rich solutions	<80	<175	All	S-1	8
Sulfuric acid concentration >85%	<38	<100	All	S-1	6
	85% - <1%	<230	<450	All	A-8
Hydrofluoric acid concentration of >96%	<38	<100	All	S-9	6

## General Notes:

- The materials for pump parts for each material class are given in Appendix H.
- Specific materials recommendations should be obtained for services not clearly identified by the service descriptions listed in this table.
- Cast iron casings, where recommended for chemical services, are for non-hazardous locations only. Steel casings (2.11.1.4) should be used for pumps in services located near process plants or in any location where released vapor from a failure could create a hazardous situation or where pumps could be subjected to hydraulic shock, for example, in loading services.
- Mechanical seal materials: For streams containing chlorides, all springs and other metal parts should be Alloy 20 or better. Buna N and Neoprene should not be used in any service containing aromatics. Viton should be used in services containing aromatics above 95°C (200°F).

## Reference Notes:

- Oxygen content and buffering of water should be considered in material selection.
- The corrosiveness of foul waters, hydrocarbons over 230°C (450°F), acids, and acid sludges may vary widely. Material recommendations should be obtained for each service. The material class indicated above will be satisfactory for many of these services, but must be verified.
- If product corrosivity is low, Class S-4 materials may be used for services at 231°-370°C (451°-700°F). Specific material recommendations should be obtained in each instance.
- All welds shall be stress relieved.
- Alloy 20 or Monel pump material and dual mechanical seals should be used with a pressurized seal oil system.
- For seawater service, the purchaser and the vendor should agree on the construction materials that best suit the intended use.
- Class A-7 materials should be used except for carbon steel casings.

<sup>a</sup>API Standard 610, 8th Edition (Reference 1)

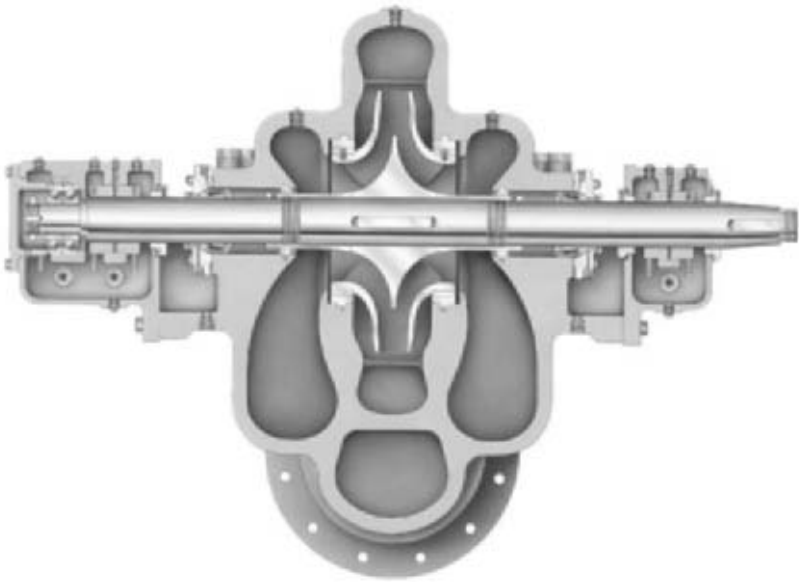
where the differential head is mostly static, such as in mountainous areas, pumps are often installed in parallel. A series installation arrangement in a static system would be unsuitable because the differential head required could not be obtained unless all of the units were operating. In certain cases, however, where differential head requirements exceed levels practical for a single multistage pump, a combination of series and parallel arrangements may be desirable.

**Construction** A single-stage double-suction pump, a two-stage double-suction pump, and a four-stage pipeline pump are shown in Figures 9, 10, and 11, respectively. All the units are double volute and are of axially split construction. The single-stage double-suction

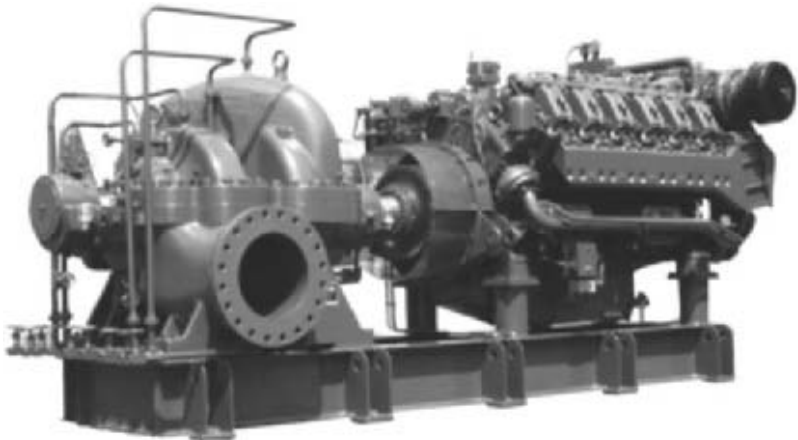
TABLE 2 Materials for pump parts (Courtesy of the American Petroleum Institute)<sup>a</sup>

Part	Full Compliance Material?	Material Class and Material Abbreviations <sup>b</sup>												
		I-1	I-2	S-1	S-3	S-4	S-5	S-6	S-8	S-9	C-6	A-7	A-8	D-1
		CI	CI	STL	STL	STL	STL	STL	STL	STL	12% CHR	AUS	316AUS	DUPLX
		CI	BRZ	CI	NI-RESIST	STL	STL 12% CHR	12% CHR	316 AUS	MONEL	12% CHR	AUS (1&2)	316 AUS(1&2)	DUPLX
Pressure Casting	Yes	Cast iron	Cast iron	Carbon steel	Carbon steel	Carbon steel	Carbon steel	Carbon steel	Carbon steel	Carbon steel	12% CHR	AUS	316 AUS	Duplex
Inner case parts (bowls, diffusers, diaphragms)	No	Cast iron	Bronze	Cast iron	Ni-resist	Cast iron	Carbon steel	12% CHR	316 AUS	Monel	12% CHR	AUS	316 AUS	Duplex
Impeller	Yes	Cast iron	Bronze	Cast iron	Ni-resist	Carbon steel	Carbon steel	12% CHR	316 AUS	Monel	12% CHR	AUS	316 AUS	Duplex
Case wear rings	No	Cast iron	Bronze	Cast iron	Ni-resist	Cast iron	12% CHR	12% CHR	Hard Faced 316 AUS (3)	Monel	12% CHR hardened	Hard Faced AUS (3)	Hard Faced 316 AUS (3)	Duplex (3)
Impeller wear rings	No	Cast iron	Bronze	Cast iron	Ni-resist	Cast iron	12% CHR Hardened	12% CHR Hardened	Hard faced 316 AUS (3)	Monel	12% CHR Hardened	Hard Faced AUS (3)	Hard Faced 316 AUS (3)	Duplex (3)
Shaft (2)	Yes	Carbon steel	Carbon steel	Carbon steel	Carbon steel	Carbon steel	AISI 4140	AISI 4140 (4)	316 AUS	K-Monel	12% CHR	AUS	316 AUS	Duplex
Shaft sleeves, packed pumps	No	12% CHR hardened	Hard bronze	12% CHR hardened	12% CHR hardened or hard faced	12% CHR hardened or hard faced	12% CHR hardened or hard faced	12% CHR hardened or hard faced	Hard Face 316 AUS (3)	K-Monel, hardened	12% CHR hardened or hard faced	Hard Faced AUS (3)	Hard Faced 316 AUS (3)	Duplex (3)
Shaft sleeves, mechanical seals	No	AUS or 12% CHR	AUS or 12% CHR	AUS or 12% CHR	AUS or 12%CHR	AUS or 12% CHR	AUS or 12% CHR	AUS or 12% CHR	AUS or 12% CHR	K-Monel, hardened	AUS or 12% CHR	AUS	316 AUS	Duplex
Throat bushings	No	Cast iron	Bronze	Cast iron	Ni-resist	Cast iron	12% CHR	12% CHR	316 AUS	Monel	12% CHR hardened	AUS	316 AUS	Duplex
Interstage sleeves	No	Cast iron	Bronze	Cast iron	Ni-resist	Cast iron	12% CHR hardened	12% CHR hardened	Hard Faced 316 AUS (3)	K-Monel, hardened	12% CHR hardened	Hard Faced AUS (3)	Hard Faced 316 AUS (3)	Duplex (3)
Interstage bushings	No	Cast iron	Bronze	Cast iron	Ni-resist	Cast iron	12% CHR hardened	12% CHR hardened	Hard Faced 316 AUS (3)	K-Monel, hardened	12% CHR hardened	Hard Faced AUS (3)	Hard Faced 316 AUS (3)	Duplex (3)
Seal gland	Yes	316 AUS (5)	316 AUS (5)	316 AUS (5)	316 AUS (5)	316 AUS (5)	316 AUS (5)	316 AUS (5)	316 AUS (5)	Monel	316 AUS (5)	316 AUS (5)	316 AUS (5)	Duplex (5)
Case and gland studs	Yes	Carbon steel	Carbon steel	AISI 4140 steel	AISI 4140 steel	AISI 4140 steel	AISI 4140 steel	AISI 4140 steel	AISI 4140 steel	K-Monel, hardened (8)	AISI 4140 steel	AISI 4140 steel	AISI 4140 steel	Duplex (8)
Case gasket	No	AUS, spiral wound (6)	AUS, spiral wound (6)	AUS, spiral wound (6)	AUS, spiral wound (6)	AUS, spiral wound (6)	AUS, spiral wound (6)	AUS, spiral wound (6)	316 AUS, spiral wound (6)	Monel, spiral wound, PTFE filled (6)	AUS, spiral wound (6)	AUS, spiral wound (6)	316 AUS spiral wound (6)	Duplex SS spiral wound (6)
Discharge head / suction can	Yes	Carbon steel	Carbon steel	Carbon steel	Carbon steel	Carbon steel	Carbon steel	Carbon steel	Carbon steel	Carbon steel	AUS	AUS	316 AUS	Duplex
Column / bowl shaft bushings	No	Nitrite (7)	Bronze	Filled carbon	Nitrite (7)	Filled carbon	Filled carbon	Filled carbon	Filled carbon	Filled carbon	Filled carbon	Filled carbon	Filled carbon	Filled carbon
Wetted fasteners (bolts)	Yes	Carbon steel	Carbon steel	Carbon steel	Carbon steel	Carbon steel	316 AUS	316 AUS	316 AUS	K-Monel	316 AUS	316 AUS	316 AUS	Duplex

<sup>a</sup> The abbreviation above the diagonal line indicates the case material, the abbreviation below the diagonal line indicates trim material. Abbreviations are as follows: BRZ = bronze; STL = steel; 12% CHR = 12% chrome; AUS = austenitic stainless steel; CI = cast iron; 316 AUS = Type 316 austenitic stainless steel. See 2.11.1.1.

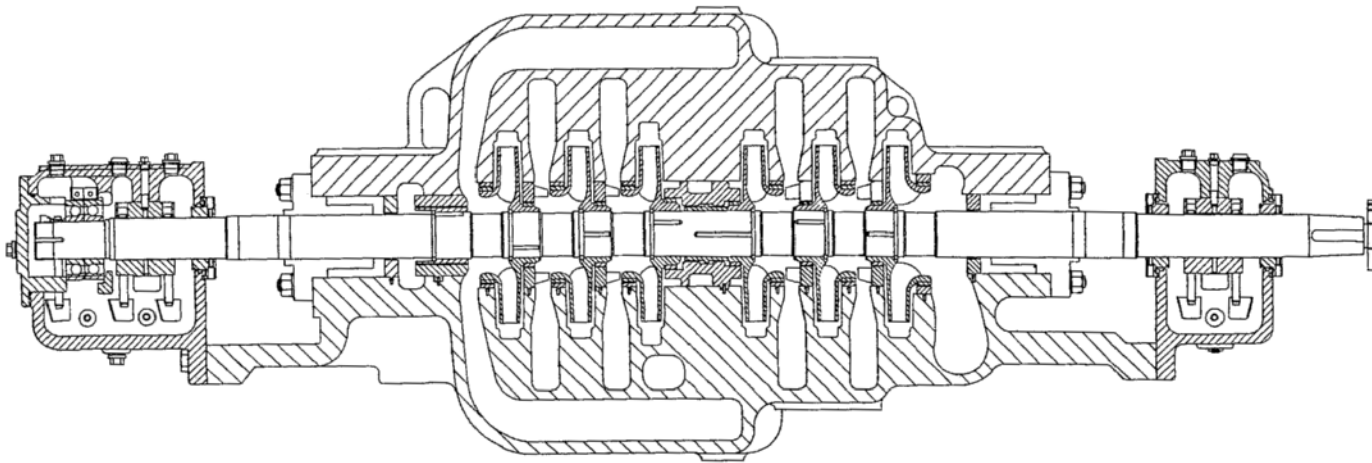


**FIGURE 9** Single-stage double suction, axially split pump (Flowsolve Corporation)



**FIGURE 10** Two-stage, double suction pump with engine drive (Flowsolve Corporation)

unit (Figure 9) is typical of those used in series operation on large diameter pipelines with capacities as high as two million barrels per day. One pipeline alone has installed more than one hundred 5000 hp (3730 kW) pumps of this construction. The two-stage double-suction pump (a smaller unit is shown in Figure 10 with an engine driver) is typical for higher head applications, and sizes are available for power ratings to 20,000 hp (15,000 kW). For lateral and smaller diameter pipeline pumping stations, multistage units (Figure 11) are used. The number of stages chosen corresponds to the differential head



**FIGURE 11** Single-suction, double-volute, axially split, six-stage pipeline pump (Flowserve Corporation)

required. Multistage units may be destaged initially to produce lower heads, with a subsequent power saving, or the nozzling may be arranged for series or parallel operation of a portion of the stages. The exact arrangement depends on the system characteristics and initial and ultimate capacities to be pumped.

All units are equipped with sleeve radial bearings and either ball or hydrodynamic thrust bearings, as dictated by power (size) and rotating speed. The single- and two-stage double suction pumps are inherently balanced axially. The multistage units utilize opposed impeller design to obtain axial balance. All modern units are equipped with mechanical seals in the seal chamber. Because most pipeline stations are now designed for unattended outdoor service, a number of safeguard controls are used. These include warnings for low suction pressure, high discharge pressure, high bearing or case temperature vibration, and excessive seal leakage. Tank farms utilize single- and double-suction inline vertical pumps or, if the tank is to be pumped dry, vertical canned pumps.

**Performance** Figure 12 indicates the typical available range for single- and two-stage pipeline pumps, and Figure 13 shows the range for multistage units. Pipeline units are custom designed, and the range is constantly being extended. Electric motors are normally used as drivers. With the utilization of gas turbines, the maximum power employed has increased dramatically in the last 30 years. Another use of gas turbines on existing pipelines is for peak capacity booster station service, in which case pumps are direct-driven at operating speeds as high as 6000 rpm.

**Materials** Pump part materials commonly specified for crude and product pipeline services are shown in Table 2 under columns S-1 through S-9. For the more aggressive services and liquids, the higher numbered material columns are preferred. All these material columns utilize carbon steel pump casings; the impellers, wear rings, and shaft materials are changed as the material grades increase in alloy and hardness (wear rings) with advancing material column grade number.

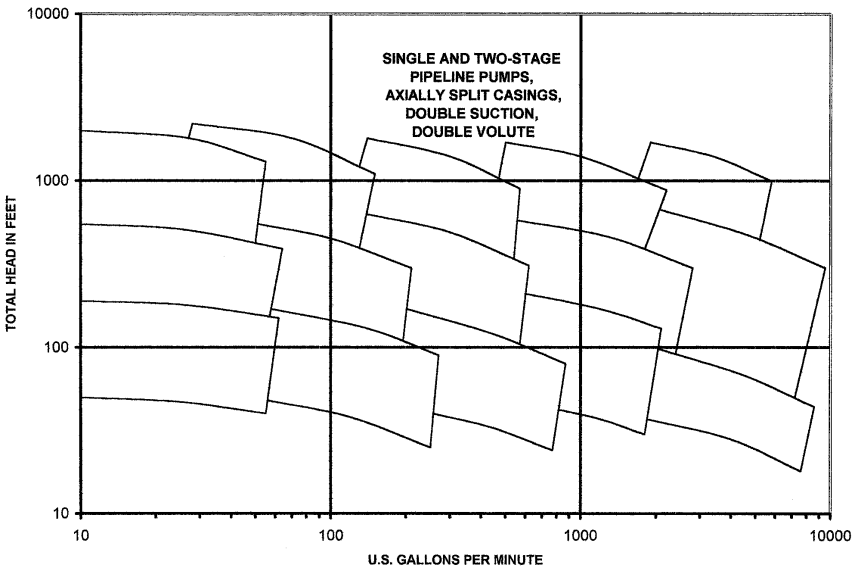


FIGURE 12 Performance coverage for single- and two-stage pipeline pumps

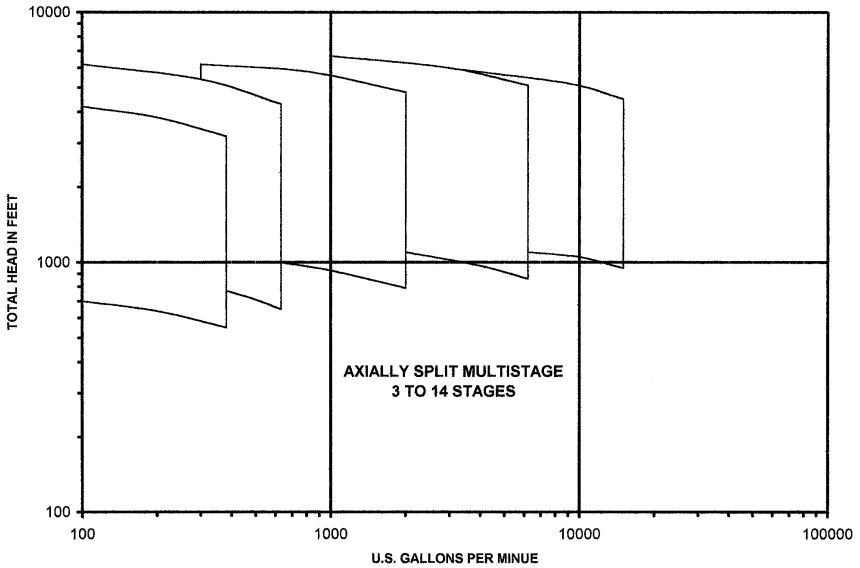


FIGURE 13 Performance coverage for multistage, axially split pumps

**Pumping Stations** The typical piping of a main line pump station in which the units are arranged in series is shown in Figure 14. As pipeline capacities have increased, one of the major problems has been the pressure loss at each station. For the station shown, three discharge valves (one 16 in (406 mm) ball valve manifolded in parallel with two 24 in (610 mm) control valves) were used. This arrangement limited the calculated pressure drop to that of a length of 36 in (914mm) pipe equal to the distance across the manifold and still allowed the use of control valves of proven size. When line conditions require throttling, the 16 in (406 mm) ball valve is first completely closed. If additional throttling is needed, the two 24 in (610 mm) control valves are closed to produce the required pressure drop. In order to move scrapers or batch separators through each station without interrupting flow through the pumps, signals (PIG SIG), hydraulically operated 24 in (610 mm) valves, and sequence control wiring are used. The distance between PIG SIG 1 and PIG SIG 2 represents the volume of station loop to be displaced. The tripping of PIG SIG 3 and PIG SIG 4 controls the valve opening and closing required to divert flow from the station discharge piping to behind the scraper or batch separator, thus forcing it to leave the station in the same relative position as it entered. Elbows at pump suction are arranged to avoid uneven flow distribution in the inlet of the double suction impeller.

Pipeline pumps are tested in accordance with Hydraulic Institute Standards. Reduced speed tests may be required because of the power limitations of manufacturing plants and available drivers, and such tests have proven to be extremely accurate indicators of full speed performance.

## SPECIAL SERVICES

**Waterflood** Centrifugal pumps are also used for water injection service when the capacity required is greater than 10,000 barrels per day. Injection pressures requirements vary considerably from initial startup with operating time. For high-pressure services, usually above 2500 lb/in<sup>2</sup> (17Mpa), barrel-type pumps are used.

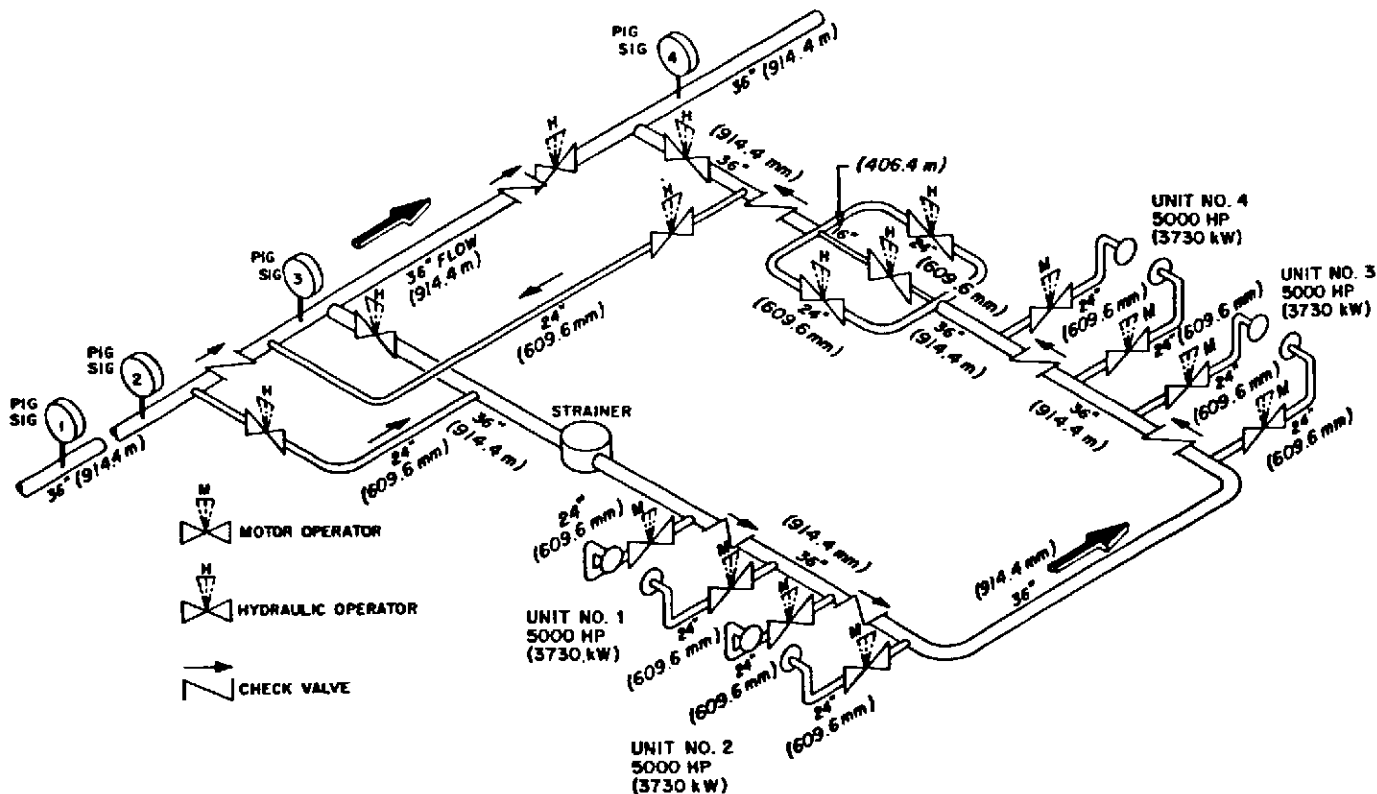


FIGURE 14 Main line pumping station piping layout

Barrel-type pumps (Figure 15), operating in series to speeds in excess of 6000 rpm using gears and gas turbine or engine drivers, are capable of injection pressures in excess of 8000 lb/in<sup>2</sup> (55 MPa) gauge. The barrel construction is typically of forged steel with an austenitic stainless steel welded overlay applied in areas of high velocity. Barrel-type casings are hydrostatically tested to 12,000 lb/in<sup>2</sup> (83 MPa) gauge and beyond (usually 1½ times barrel design pressure).

Most waterflood injection pressure requirements, however, are such that axially split multistage pumps of the design shown in Figure 4 may be used. As many as 14 stages in one pump are often utilized to obtain the required differential head. In addition, if still greater pressures are required, the units may be piped in series. Axially split pumps have been hydrostatically tested to 6000 lb/in<sup>2</sup> (41 MPa) for a working pressure of 4000 lb/in<sup>2</sup> (27.5 MPa).

For applications where injection liquid is highly corrosive, materials of construction may include austenitic and duplex stainless steels. Commonly used materials for major pump components in waterflood applications are shown in Table 2 under material columns A-8 and D-1. Seal chambers for high pressure and high-speed services may contain a limited leakage breakdown bushing preceding a mechanical seal for increased reliability.

**Reactor Feed Pumps** One of the most difficult services encountered in the petroleum industry is the high-temperature, high pressure reactor feed, or charge pump. Type BB5 pumps, such as the one shown in Figure 5, are most commonly used for these services. Reactor feed pumps can be subject to operating temperatures in excess of 800°F (425°C) with discharge pressures in excess of 2500 lb/in<sup>2</sup> (17 MPa) gauge. To produce such high pressures requires either a large number of stages or high speed. Historically, refiners have preferred 3600 rpm (3000 rpm in 50 Hz areas) pumps with large numbers of stages. However, the trend more recently is for shorter, more robust pumps, with fewer stages operating at higher speeds.

The high temperatures and corrosiveness of the pumped fluids often require the use of a number of dissimilar metals. Compensation must be made for the different rates of expansion of the various components at operating temperatures. This presents a critical design problem for the manufacturer and a significant operability issue for the refinery. Extreme care is required in the startup and operation of these units. Even so, it is common for refiners to buy only a single pump for such services (no spare), and for these pumps to run continuously for five or more years without maintenance.

**LPG Pumps** Multistage axially split centrifugal pumps have been installed in pipelines transporting liquefied petroleum gases (LPG) with specific gravities as low as 0.35. The low lubricity of the pumped fluid required careful selection of wearing part materials. Seal chambers may utilize single or double (dual) mechanical seals, depending upon local environmental issues. At ambient temperatures, the suction pressures can be 1000 lb/in<sup>2</sup> (69 MPa) gauge or more. These fluids may also experience a large temperature rise as a result of compression that occurs during the pumping process.

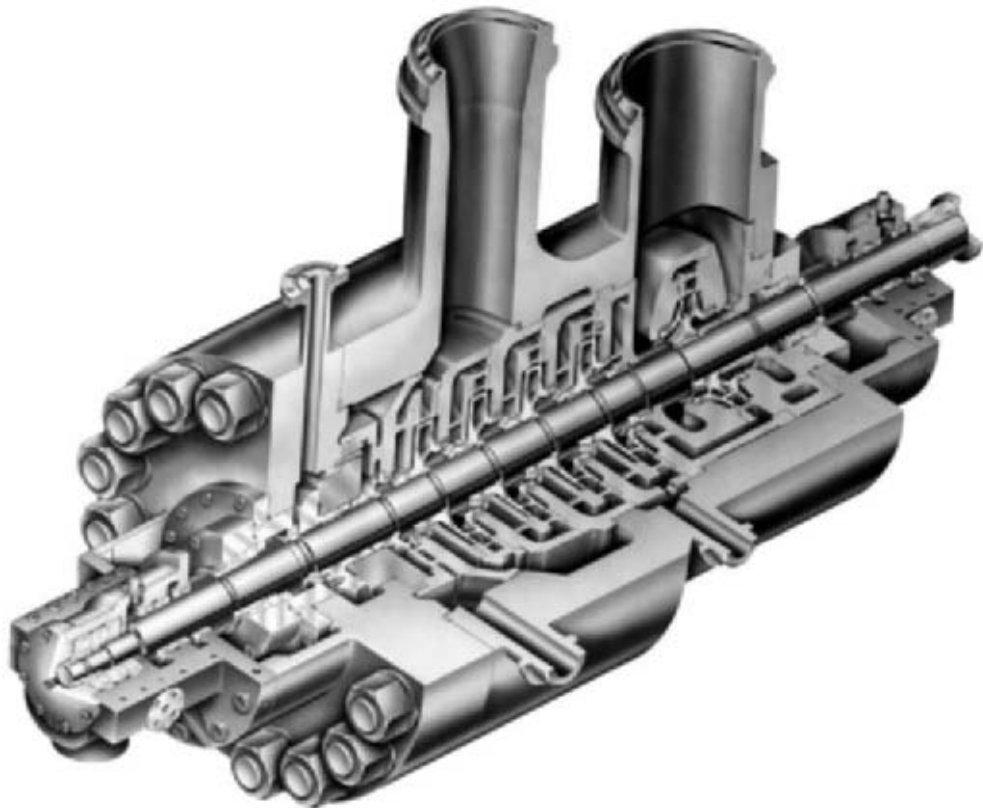
Many additional special designs could be mentioned. The wide range of operating conditions and products in the petroleum industry frequently requires pumps specifically engineered for a certain service. The pump designer is continually challenged to provide a safe, reliable, and economical design.

## **PUMPING OF VISCOUS LIQUID**

---

Viscosity of the pumped liquid is a very important factor that must be considered to properly select and size pumps in many petroleum industry applications. A thorough understanding of the relationship between liquid viscosity and pump performance is essential to proper sizing of both the pump and its driver.





**FIGURE 15** Double-casing multistage barrel-type pump with radially split inner casing (Flowsolve Corporation)

**TABLE 3** Effect of viscosity on performance of a typical centrifugal pump operating at best efficiency point

Viscosity SSU (cSt)	Capacity gpm (m <sup>3</sup> /h)	Total head ft (m)	Efficiency %	Brake power bhp (kW) <sup>a</sup>
Nil	3000 (681)	300 (91)	85	241 (180)
500 (110)	3000 (681)	291 (89)	71	279 (208)
2,000 (440)	2900 (658)	279 (85)	59	312 (233)
5,000 (1100)	2670 (606)	264 (80)	43	373 (278)
10,000 (2200)	2340 (531)	243 (74)	31	417 (311)
15,000 (3300)	2100 (477)	228 (69)	23	473 (353)

<sup>a</sup>All values of brake power based on liquid having a specific gravity of 0.90.

Centrifugal pumps are routinely applied on services with liquids having viscosities below 3000 Saybolt Seconds Universal (SSU) or 660 centistokes (cSt), and may be used up to at least 15,000 SSU (3300 cSt). (For background information on viscosity, refer to Section 8.1.) Centrifugal pumps are sensitive, however, to changes in viscosity and will exhibit significant reductions in capacity and head and rather drastic reductions in efficiency at moderate to high values of viscosity. The extent of these effects may be seen in Table 3, constructed with the aid of Figure 16, which provides a convenient means of determining the viscous performance of a centrifugal pump when its cold water performance is known. To use Figure 16, enter at the bottom with the pump capacity, and then proceed vertically upward to the total head (head per stage for multistage pumps), proceed horizontally right or left to the viscosity value, and finally proceed vertically upward again to the curves for correction factors. The values thus obtained for the respective correction factors are multiplied by the water performance values for capacity, total head, and efficiency to obtain the equivalent values for viscous performance. By using the individual correction factors for total head, it is even possible to approximate the shape of the head-capacity characteristic curve when the viscous liquid is being pumped, at least to 120% of the best efficiency point flow ( $Q_N$ ). The total head at shutoff will remain essentially constant regardless of liquid viscosity.

Centrifugal pump performance is nearly always specified by the pump manufacturer basic pumping clean, cold water, even when the pump has been specifically designed for petroleum industry applications. Cold water is a universal pumping medium. Pumps selections, however, must necessarily be made to satisfy viscous conditions of service and require application of these correction factors in the reverse direction. In this case, Figure 16 provides an approximation of equivalent water performance that is probably within the limits of accuracy of the graph for liquid viscosities in SSU numerically equal to pump capacity in gallons per minute. (In other words, for a pump with a capacity of 3000 gpm, Figure 16 is probably quite accurate to viscosities of 3000 SSU.) For higher viscosities, the initial solution of equivalent water performance, determined in accordance with the following paragraph, may need to be adjusted and then checked by conversion of water performance to viscous performance again.

To determine approximate equivalent water performance when required viscous pump performance is known, enter Figure 16 at the bottom with the viscous capacity, proceed vertically upward to the desired viscous head (head per stage for multistage pumps), and then horizontally right or left to the viscosity, and vertically upward to the correction factor curves for capacity and head. In this case, divide the viscous performance values by the correction factors to obtain the equivalent water performance values. The pump selection can then be made, basic ratings established for water, and efficiency can be calculated for the viscous liquid using the efficiency correction factor applied to the pump efficiency for water.

**EXAMPLE** To select a pump for 500 gpm (114 m<sup>3</sup>/h) of 3000 SSU (660 cSt) liquid against a head of 150 ft (46 m), proceed as follows:

From Figure 16, determine  $C_Q = 0.80$  and  $C_H = 0.81$ .

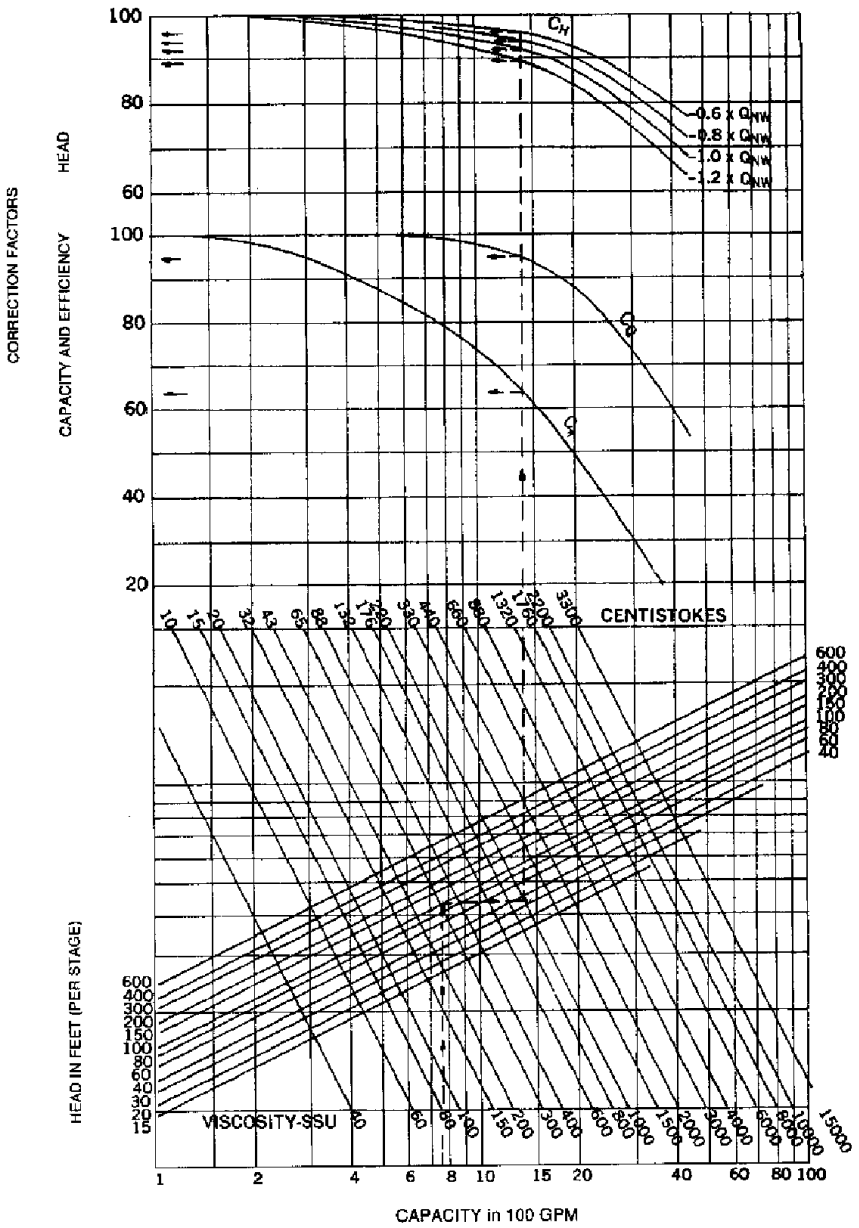


FIGURE 16 Performance correction chart for viscous liquids—Hydraulic Institute ANSI/HI 2000 Edition Pump Standards (Reference 3).

The water capacity, then, is

$$\text{In USCS units} \quad Q_W = 500/0.80 = 625 \text{ gpm}$$

$$\text{In SI units} \quad Q_W = 114/0.80 = 142 \text{ m}^3/\text{h}$$

And the water head is

$$\text{In USCS units} \quad Q_H = 150/0.81 = 185 \text{ ft}$$

$$\text{In SI units} \quad Q_H = 46/0.81 = 57 \text{ m}$$

For 625 gpm (142 m<sup>3</sup>/h), 185 ft (57 m), 3000 SSU (660 cSt), Figure 16 indicates  $C_Q = 0.83$ ,  $C_H = 0.85$ , and  $C_E = 0.42$ . If the values for  $C_Q$  and  $C_H$  obtained from these calculations are roughly within 2% of those taken directly from Figure 16, the pump may be selected on the basis of the water capacity and water head already obtained. Because, in this case, these values differ from the first approximation by more than 3%, the water performance should be adjusted as follows:

Adjust the water capacity:

$$Q_W \times 0.80/0.83 = 602 \text{ gpm (137 m}^3/\text{h)}$$

Adjust the water head:

$$H_W \times 0.81/0.84 = 178 \text{ ft (55 m)}$$

Select the pump for 602 gpm (137 m<sup>3</sup>/h) and 178 ft (55 m) and determine water efficiency from the manufacturer's rating. Assuming the water efficiency in this case is 75%, the viscous efficiency

$$E_V = 0.75 \times 0.42 = 0.315, \text{ or } 31.5\%.$$

For a specific gravity (sp. gr.) of 0.90,

In USCS units

$$\begin{aligned} \text{bhp} &= \frac{\text{gpm} \times \text{ft of head} \times \text{sp. gr.}}{3960 \times \text{efficiency}} \\ &= \frac{500 \times 150 \times 0.90}{3960 \times 0.315} \\ &= 54 \end{aligned}$$

In SI units

$$\text{brake kW} = \frac{\text{m}^3/\text{h} \times \text{m} \times \text{sp. gr.}}{376.5 \times \text{efficiency}} = \frac{114 \times 150 \times 0.90}{376.5 \times 0.315} = 40$$

The Hydraulic Institute Standards limit the use of Figure 16 to radial flow centrifugal pumps with open or closed impellers, handling Newtonian liquids within the pump's normal operating range and within the capacity limits indicated on the chart. Failure to heed these limitations may result in misleading expectations of performance with viscous liquids. Tests on vertical turbine-type pumps, for example, which normally have mixed-flow rather than radial-flow impellers, have shown that, although the viscous efficiency predicted from this chart is quite accurate, the viscous head and viscous capacity predictions are substantially above the demonstrable values. In other words, the performance reductions determined from the chart would not be severe enough for that type of pump. For centrifugal pumps that do not fall within the limits of applicability of Figure 16, viscous performance can be accurately established only by testing.

**DISPLACEMENT PUMPS** Both rotary and reciprocating pumps are also frequently used for pumping viscous fluids, and some types are well suited for use where viscosities are beyond the limits for centrifugal pumps. In fact, many common designs are suitable only for use with liquids that are at least moderately viscous because they depend on the viscosity to maintain the lubricating and sealing films between various internal parts of the pumps. Most gear pumps and screw pumps are in this category.

As with centrifugal pumps, the performance of displacement pumps may be significantly affected by changes in liquid viscosity, but the nature of these changes may be quite different. At constant speed, changes in viscosity are likely to have little or no effect on pump capacity. Total head, or differential pressure across the pump, would probably increase with increasing viscosity because of higher system resistance. Thus, the brake power required would increase with even though pump efficiency would not suffer nearly so drastically, if at all, as for a centrifugal pump.

The influence of pump design on how performance varies with viscosity is greater in displacement pumps than in centrifugal pumps. Because there are so many designs, it is not practical to attempt to provide a general means of determining their viscous performance here. This should be done only on the basis of information provided by the pump manufacturer.

#### **REFERENCES AND FURTHER READING**

---

1. American Petroleum Institute Standard 610. "Centrifugal Pumps for Refinery, Heavy Duty Chemical, and Gas Industry Services." 8th ed., 1995.
2. American Petroleum Institute Standard 682. "Shaft Sealing Systems for Centrifugal and Rotary Pumps." 1st ed., 1994.
3. American National Standard for Centrifugal Pumps for Design and Application, ANSI/HI 1.3-2000, Section 1.3.4.1.11, Hydraulic Institute, Parsippany, NJ [www.pumps.org](http://www.pumps.org).
4. Hydraulic Institute ANSI/HI 2000 Edition Pump Standards, Hydraulic Institute, Parsippany, NJ [www.pumps.org](http://www.pumps.org).

---

# SECTION 9.8

---

# PULP AND PAPER MILLS

---

J. F. GIDDINGS  
D. R. ROLL  
C. A. CAPPELLINO

## GLOSSARY

---

**additive** An additive is any material such as clay, filler, or color added to stock to contribute specific properties.

**bleaching** Bleach is the process of removing the lignin and other color-forming substances from the stock to render it white.

**chest** A chest is a vessel for storing pulp.

**cellulose** Cellulose is a carbohydrate that is the primary substance in plant fibers. It is extracted from the plant to make paper products.

**consistency** Consistency is the proportion by mass of fibers in a mixture of fibers and water.

**cooking** Cooking is the action of the chemical used to break down lignin bond between cellulose fiber in wood and other organic matter.

**deinking** Drinking is the process of removing ink particles from recycled paper such as newsprint or magazines.

**digester** A digester is a pressure vessel used to contain chemical action of cooking chemical and raw cellulose material. Digesters may be of the batch or continuous flow type.

**evaporator** In the recovery of chemicals from the cooking liquor in a chemical pulp mill, an evaporator is used to concentrate the liquor (remove water) so the concentrated liquor can be incinerated in the recovery furnace.

**fiber** Fibers are the vascular bundles found in plants that are extracted and used to make paper.

**fourdrinier** Fourdrinier is the continuous wire upon which pulp or paper sheet is produced.

**freeness** Freeness is a measure of degree of refinement of stock and, hence, of its ability to drain water.

**groundwood** Groundwood is a mechanical pulp formed by simple grinding to break down wood structure.

**headbox** A headbox is a specialized nozzle that takes flow from the fan pump and discharges a uniform layer of white water (stock) onto the forming wire of the paper machine.

**kraft process** The kraft process is a method of separating cellulose fiber from lignins by using caustic soda in presence of sulfur radical.

**lignin** Lignin is a generic term used to refer to the complex organic matter present in wood that acts as binding agent for cellulose fibers.

**liquor** *Black liquor*: Solution of water plus residual organic matter (or lignins) in the wood after washing of raw stock. *Green liquor*: solution of smelt from recovery furnace when dissolved in either water or weak washed liquor. *White liquor*: Solution of caustic soda (or other alkali), sometimes in the presence of a sulfur radical; this is the liquor charged to the digester for cooking.

**neutral sulfite** Neutral sulfite is made through a cooking process using a solution of about 10% sodium sulfite and 5% caustic soda mixed for cooking wood or agricultural fiber to produce high-yield pulp.

**paper** Paper is a sheet of cellulose or other fibers formed on a screen from a mixture of fibers in water. Thin absorbent paper is known as tissue; thicker grades of paper are called paperboard.

**refining** Refining is a mechanical process carried out on stock to improve the ability of the fiber to form paper sheet. Different techniques are employed—some designed to shorten the fiber, others to increase the amount of fibrils (or “whisker”) on the fiber.

**soda process** A soda process is similar to kraft process but uses caustic soda without presence of sulfur.

**stock** Stock is a generic term for the suspension of cellulose fiber in water or chemicals. *Bleached stock*: The same after bleaching. *Brownstock*: The same before bleaching. *Raw stock*: The product discharged from digester(s) before any washing or other treatment. It is also referred to as pulp.

**sulfite process** A sulfite process is the method of separating cellulose fiber from lignin with acid. This method is becoming obsolete because of its inherent detrimental impact on the environment.

**vat** A vat is a semicylindrical mold or container for holding stock during washing or sheet formation.

**yield** Yield is the percentage of cellulose fiber in the form of pulp produced from a given weight of wood or other raw material. *High yield*: The same when some lignins are allowed to remain in the finished product.

## GENERAL

---

Apart from the petrochemical industry, there are few continuous-process plants with pumps as much in evidence and with reliability as essential as in the pulp and paper industry.

Before paper leaves the machine room, 100 to 200 tons of water will have been pumped to the mill for every ton of paper produced. These figures represent only the basic amount of water taken from a river and rejected as effluent; the amount of liquid circulated is several times greater.

Although many attempts have been made to utilize a dry process for papermaking, both pulping (the separating of crude fibers from the raw material) and papermaking (actual treatment of the fiber and mechanical formation of the sheet) still require water as the medium to convey fiber. Throughout the mill, pumps are used to transfer or circulate

fibers suspended in water (stock), chemicals or solids in solution (liquors), or residues and waste matter as slurries, as well as to supply water for general services.

There are at least 150 pumps installed in a modern pulp mill and another 50 or so in a paper mill. About 1000 kW · h is required for the production of one ton of pulp, and a further 500kW · h for the finished paper. Of this total, about 25% is used in pumping. This means that even in a medium-size mill, the installed power required for pumps alone is approximately 10,000 hp (7457 kW), and often it is much higher.

## PULPING PROCESS

---

**Raw Materials** In the past, the traditional fibrous raw materials for the manufacture of paper were cloth and agricultural residues; today the vast bulk of cellulose pulp is made from wood. Although over half of this is produced from softwoods (long-fibered), an increasing amount is being now produced from hardwoods (short-fibered). Traditional raw materials such as linen, cotton waste, straw, and agricultural residues are still used in small quantities, particularly where the paper sheet requires special properties. These distinctions are important in the selection of pumps, for the liquors have different characteristics. For example, straw black liquor is much more viscous than wood black liquor, and the proper corrections must be made in calculating the pump performance and pipe frictional losses.

Many grades of paper include fiber recovered from waste paper—both pre- and post-consumer. Recently, because of environmental concerns, much emphasis has been placed on recycling post-consumer paper products. Specialized plants exist for the recovery and processing of recycled fiber before it is used for papermaking. Some of the different types of recycled fiber are ONP (old newsprint), OCC (old corrugated containers), and MOW (mixed office waste). Special care is needed in the selection of pumps to handle recycled stock because of the large amount of foreign matter present—rope, string, metal, synthetic fibers and adhesive materials—all of which can cause problems in the process and pumping. Deinking is also widely used in the processing of recycled fibers. Flotation cell deinking, a popular method, uses large amounts of entrained air, which has a dramatic effect on centrifugal pump performance and must be accounted for.

**Groundwood Pulp** This type of pulp is produced by simply grinding away wood by mechanical action. Almost all of the wood is used in the pulp, including many of the resins and other complex organic compounds. The fibers are bruised so the pulp has inferior strength.

Large amounts of water are required for cooling and for carrying away the groundwood pulp; the latter is usually acidic (pH 4 to 5), and so corrosion-resistant materials must be used. The pulp is used primarily for newsprint and magazines. Depending on the end use, some mechanical treatment (refining) may be required to alter the characteristics of the pulp, particularly the viscosity. In some cases, a mild bleach may be used to improve the color.

**Refiner Mechanical Pulp** The refiner mechanical pulping process utilizes a disc refiner to reduce wood chips to fibers. It produces a longer fibered pulp than conventional groundwood, but not as long as the chemical pulps. The pulp is therefore somewhat stronger and freer than SGW, but not nearly as strong as kraft pulp. RMP is actually the first of many processes utilizing the disc refiner to produce pulp. The processes vary as to the number of refining stages, refining pressure, temperature, and pre-treatment of the chips (steaming, chemical pre-treatment and so on). Two of the more popular versions are TMP (thermomechanical pulp), in which chips are pre-softened with steam, and CTMP (chemithermomechanical pulp), in which they receive an additional chemical pre-treatment. RMP pulps do not require a rigorous bleaching process in contrast to chemical pulps.



**Chemical Pulping** Wood is a complex, nonuniform material containing about 50% by weight cellulose fiber, 30% lignins, and 18 to 20% carbohydrate. The remainder is proteins, resin, and other complex organic compounds that vary from one species to another. Cellulose resists attack from most chemicals, whereas the carbohydrates and other organic materials generally form compounds with the chemical cooking liquor. Some paper products can use the carbohydrate fraction to contribute bulk to the sheet, and for such papers groundwood and RMP and other mechanical pulps are used. Where high strength is required, cooking is necessary to separate the fibers completely from the remainder of the wood.

Most cooking of wood is done in a pressure vessel at high temperature and pressure in the presence of an acid or alkali.

There is considerable tradition in chemical pulping, and a number of different processes are used. For many years the traditional method of producing pulp for high-grade papers was the acid sulfite process. This has been largely superseded in recent years by an alkaline process using sodium-based liquors in the presence of a sulfur radical; this is known as the sulfate or kraft process. The main reasons for the change to the sulfate process have been lower corrosion rates, ease of chemical recovery, and a stronger pulp. The properties of the liquids pumped in the two processes are different, and the pumps require different materials of construction.

**Typical Sulfate Process** Pulpwood logs are first chipped to about  $\frac{3}{4}$  by  $\frac{1}{8}$  in (19 by 3 mm) and then charged into either a continuous digester or a series of batch digesters. Digester capacities range from approximately 100 air-dried tons per day to over 2000 air-dried tons per day, necessitating a wide range of hydraulic coverage for digester pumps. Cooking liquor (NaOH plus up to 30%  $\text{Na}_2\text{S}$ ) is then allowed to react with the wood chips for 2 to  $2\frac{1}{2}$  h at a temperature up to 350°F (177°C) and a pressure in the digester of 80 to 100 lb/in<sup>2</sup> (551 to 689 kPa). In many mills, the heating of the chips and cooking liquor is by direct steam injection to the digester. In others, some form of indirect heating is used with a closed liquor recirculation system. In the latter case, the digester circulating pumps are a critical item because they must handle hot caustic solutions and entrained solid matter in a closed, pressurized circuit. After cooking, the contents of the digester are discharged to atmospheric pressure into a vessel called the blow tank, where the sudden expansion causes the fibers to separate from the liquid, which is now known as black liquor.

At this point, the process splits into two streams—one for fiber processing and the other for chemical recovery. The fiber is washed and screened and then formed into a pulp or paper sheet. The black liquor is washed from the pulp and treated for chemical recovery. Because the most troublesome liquors are to be found in the recovery process and bleach plant, the selection of these pumps is critical for the successful operation of the process.

The chemistry of the recovery process is as follows: After concentration of the black liquor in multiple-effect evaporators to about 50% total solids, the final concentration to 60 to 65% is done by direct contact with hot flue gas from the waste heat or recovery boiler. The 65% concentration black liquor is mixed with salt cake ( $\text{Na}_2\text{SO}_4$ ) before being sprayed into the furnace under pressure generated by high-pressure pumps. The furnace atmosphere is maintained with a minimum of excess air so the  $\text{Na}_2\text{SO}_4$  is reduced to  $\text{Na}_2\text{S}$ , and sodium carbonate ( $\text{Na}_2\text{CO}_3$ ) is formed in the process. These molten chemicals run out as a smelt and are dissolved in a tank to form green liquor. This liquor is then causticized with lime to form caustic soda (NaOH), with the  $\text{Na}_2\text{S}$  still present along with other residual chemicals, thus forming the regenerated cooking liquor known as white liquor. The calcium carbonate ( $\text{CaCO}_3$ ) formed is burned in a lime kiln for reuse in causticizing. Various lime slurries and residues are formed during this process. The white liquor is then clarified and reused in the digesters, completing the cycle, as shown in Figure 1.

There are a variety of other pulping processes in use, but the sulfate process offers so many advantages that almost all recent installations have been of this type.

**Bleaching** Bleaching may be considered an extension of the cooking process, the object being to remove the coloring matter, carbohydrate, and lignins to that the remaining pulp

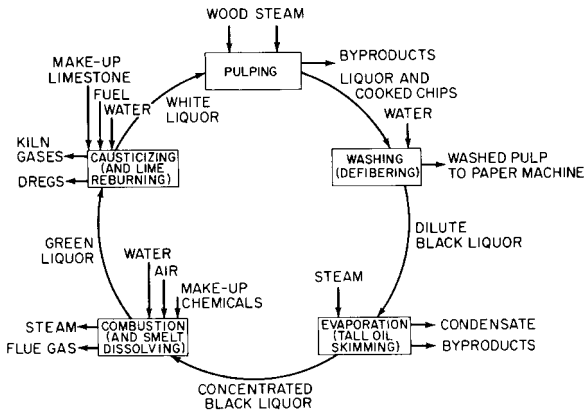


FIGURE 1 The recovery cycle in the sulfate process.

contains a maximum percentage of alpha cellulose, which is the purest cellulose form and the one most resistant to attack from normal chemicals. Bleaching is carried out to reach a degree of reflectance of monochromatic light and called pulp brightness. Because of resistance to attack, special highly reactive chemicals must be used for bleaching. The traditional chemical used for bleaching is chlorine, which is highly selective at attacking the lignin while resisting attack of the cellulose. Chlorine has a tendency, however, to form pollutants in the bleach plant effluent and is therefore being replaced with other chemicals such as chlorine dioxide, hydrogen peroxide, and gaseous oxygen and ozone. Chlorine dioxide produces highly corrosive liquors in the bleach plant.

## LIQUIDS PUMPED IN A MILL

There are, broadly, three categories of liquids to be pumped in a paper mill:

1. Water and similar fluids
2. *Liquors and slurries*—mainly chemicals and solids in solution or suspension
3. *Stock*—suspension of cellulose fibers in water

**Water** Apart from the quantities involved, there are no special requirements concerning the water in pulp and paper mills because operating conditions are well within normal limits. However, iron and carbon steel piping should not be used in bleach pulp mills because of iron pickup.

Process water treatment is frequently used to purify process water for the mill and to remove undesirable elements such as iron. Higher-quality water is required for chemical repARATION in the bleach plant and for boiler feedwater where demineralizer plants are used. Rubber- or epoxy-resin-lined pumps are used for those components in contact with the demineralized water.

**PUMPS FOR MILL WATER** For the majority of pumps, standard cast iron or stainless steel fittings are used except as noted for demineralized water. In many mills, however, stainless-steel-fitted pumps are standard because this permits a minimum number of spares to be held in stock for other duties.

In the paper mill, water used to form the sheet on the paper machine has a very low fiber content— $\frac{1}{2}$  to 1% consistency—and is known as white water. Fiber contents this low

usually do not cause any pumping problems except in wear ring areas where flashing or slotting is used to keep leakage paths open and free from binding.

Much of this water is recirculated, and where bleached products are produced, pumps must be constructed an austenitic stainless steel.

**Liquors and Slurries** Depending on the process and the particular point in that process, the liquor characteristics may require special pumps or special materials. Although the liquor cycle is a difficult one as far as the pumps are concerned, standard designs should be used whenever possible because this reduces the number of different types of pumps in the mill. In some cases, it may be necessary to use a higher material specification than necessary to achieve interchangeability.

Liquor and slurry pumps may be grouped as follows:

**Group A**—Standard designs suitable for most process uses where corrosion or erosion is not a major factor. Impellers are typically stainless steel with casings of cast iron.

**Group B**—Standard end-suction designs suitable for corrosive liquors. All liquid end components are typically 316 stainless steel. Duplex stainless steels may be used where erosion may be a factor.

**Group C**—Standard or nonstandard designs suitable for special services. Pumps are similar to group B for most applications but are of 317 or 317L stainless steel. For most corrosive services, glass-reinforced epoxy, resin, titanium, super austenitic stainless steels are used for both impeller and casing. Mechanical seals in place of packed boxes or dynamic seals are usually fitted to these pumps.

Recommendations for liquor and slurry pumps are

1. All liquor pumps should be classified as slurry type with open nonshrouded impellers of the end-suction and back pull-out type. Simply supported, double suction pumps are also used for fibrous slurries (stock)—particularly  $\frac{1}{2}\%$  to 3% consistency stock on the paper machine. This includes most fan and cleaner pump applications.
2. On group A and B pumps, sealing is accomplished with dynamic seals, mechanical seals, or packed stuffing boxes.
3. For group C pumps, in particular, it may be necessary to depart from a standard design or type of centrifugal pump. For example, if a positive displacement characteristic is required, a screw-type pump may be used with confidence. In addition, all pumps handling stock with consistency above 6% must be regarded as nonstandard types.

After the pumps are grouped, it becomes necessary to decide which pump may be used for specific liquors. Requirements for individual mills will differ in detail, but the following may be taken as an indication of current practice, particularly in modern sulfate (kraft) mills. In every case, manufacturers should be made aware of the liquor characteristics and of the location of the pump in the process.

**COOKING LIQUOR (WHITE LIQUOR—SULFATE PROCESS)** This is essentially an alkaline solution made by causticizing green liquor. The liquor is prepared at concentrations over the range of 50 to 100 g/liter depending on the wood species, and the amount of active alkali (expressed as  $\text{Na}_2\text{O}$ ) may be from 14 to 30% of the dry wood weight. White liquor is mainly sodium hydroxide, with a small percentage of sodium sulfide which depends on the mill sulfidity. Higher values of active chemical are used in bleached pulp mills. The term *sulfidity* is used to denote the ratio of chemicals present; it is frequently expressed as  $\text{Na}_2\text{O}$  and calculated from the expression

$$\frac{\text{Na}_2\text{S}}{\text{NaOH} + \text{Na}_2\text{S}}$$

The sulfidity value commonly used is from 20 to 30%; the higher values usually denote better chemical recovery. The specific gravity of the liquor will be approximately 1.2, and after clarification only small quantities of grit should be present. The liquor must be con-

sidered an abrasive that produces a high rate of wear on pump rotating elements. White liquor has a tendency to crystallize on internal surfaces of pipes and pumps, but there are no special viscosity problems and a pump head loss allowance of about 10% above that of water should be adequate. Group B pumps are recommended.

**BLOW TANK DISCHARGE** As the liquor introduced with the chips into the digester combines with the noncellulose and hemicellulose fractions of the wood, it changes from white liquor to black liquor before reaching the blow tank. In addition, the sudden release of pressure frees the cellulose fibers from the other matter, so the blow tank contains both raw stock (pulp) and black liquor. Pulp from the blow tank is often entrained with air, sand, and other contaminants. A stock pump, therefore, is required for this duty because the stock concentration is quite high.

**BLACK LIQUOR** For convenience these pumps are divided into three groups.

*Weak Black Liquor (Total Solids Up to 20%)* During washing, hot water is used to dissolve away the surplus organic matter from the pulp, and the liquor produced is termed *black liquor*. This liquor is a mixture of the lignins and carbohydrates in the original wood plus the cooking chemicals: it is alkaline with a solids content of 14 to 16% in a sulfate mill. The temperature will be about 180 to 190°F (82 to 87°C), and the specific gravity about 1.08. Washing is usually carried out with a minimum of three countercurrent stages, and the solids content given previously is representative of the liquor leaving the stages nearest the inlet; that is, where it is most concentrated. The quantity of recirculated liquor is quite high, and many mills have found group A pumps with stainless trim to be satisfactory and economical. With the low solids content, there are no special viscosity problems. This may be seen from Figure 2.

*Black Liquor with Total Solids of 20 to 50%* This liquor is formed by the evaporation of water from weak black liquor. The concentration is accomplished in multiple-effect evaporators, which usually discharge liquor with about 50% total solids at close to 200°F (93°C). In some odor-free installations, the solids concentration is much higher. Because of the nature of the evaporation, special pumps are usually required.

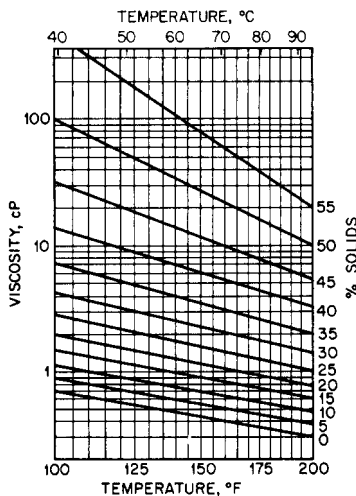


FIGURE 2 Black liquor viscosity

Liquor containing up to 50% solids is reasonably easy to pump, but allowance must be made for viscosity effects. In noting the values in Figure 2, it should be remembered that the plant must often start up cold, so cold liquor with a higher viscosity may have to be pumped. The liquor-specific gravity rises during evaporation from about 1.1 to 1.25. Group B pumps are recommended.

*Black Liquor with Total Solids of 50 to 65%* This is often referred to as heavy black liquor because the specific gravity rises to 1.35. The liquor is formed by further evaporation, either in the multiple-effect units or by contact evaporators using hot flue gas.

From a pumping standpoint, this liquor is probably the most difficult of all liquids to pump satisfactorily in pulp and paper mills. Continuous operation requires careful attention to pump sealing and maintenance. Steaming out at regular intervals of the evaporator and piping is particularly important to prevent solids buildup affecting *NPSHA* to the pumps.

No accurate figures are available for the viscosity of liquids with a solids concentration above 55% because there is wide variation in the liquors produced from different wood species and also in the liquors from the same wood of different ages. Hardwood species produce a more viscous liquor, especially eucalyptus, as well as more liquor per ton of pulp produced. Black liquor produced from straw pulping is even more viscous and, in addition, causes the deposition of silica on the walls of pumps and piping. An approximation of the viscosity of straw mill heavy black liquor may be determined from published figures, which give viscosities up to 2000 centistokes. This is probably at least 50% higher than liquor from normal long-fibered softwood.

During recovery, liquor is sprayed into the furnace for evaporation to dryness and burning. Prior to this, the make-up chemical (sodium sulfate or salt cake) is added and reduced to  $\text{Na}_2\text{S}$  in the reducing atmosphere of the furnace.

Little is known with certainty about heavy black liquor, but it does not seem to be very corrosive, and carbon steel is often used for pipework, although stainless steel pumps are fairly common. The pumps are subjected to severe duties—notably high heads, lumpy material, high temperature and pressure, and continuous service. Group B pumps are almost universally specified, often with casings of more wear-resistant material such as Alloy 20 or duplex stainless steels. In some cases, mills making straw pulp have not found suitable centrifugal pumps and have had to resort to gear pumps because of the very high viscosity of the liquor.

**GREEN LIQUOR** Green liquor is a solution of sodium carbonate and sodium sulfide plus other elements and compounds. One of these other compounds is iron sulfide in a colloidal form, which produces a greenish color. The liquor is formed by dissolving smelt from the causticizing process. Severe erosion takes place in green-liquor pumps, primarily because of the violent action inside the dissolving tank but also because of the gritty matter always present. Green liquor also builds up on the walls of pumps and piping, causing high frictional losses. The specific gravity is usually about 1.2, and an allowance of about 20% should be made for viscosity. Group B pumps are recommended for this service.

**LIME SLURRIES** In causticizing, various solutions and slurries are present that, apart from causing excessive wear in standard pumps, do not cause any problems. Thus, any normal slurry pump should prove satisfactory. In sulfate mills, the lime mud formed during green liquor causticizing presents the most serious problem, for approximately 1000 lb (500 kg) of mud may be formed for each ton (1000 kg) of pulp produced. Solid loads above 35% can occur, and frequent blockages are likely unless pumps are selected for minimizing downtime. For mild slurry duty, group B pumps with duplex stainless steel construction are satisfactory. For harsher applications, hard iron pumps like those used in the mining industry are employed.

**BLEACH PLANT LIQUOR** Most bleached pulp mills today use at least four stages of bleaching, and often six or more. Bleaching is used to remove residual lignins or to convert them to compounds that are stable regarding color and heat. The stages used include chlorination, either by hypochlorite, gaseous chlorine, (both becoming obsolete) or chlorine diox-

ide (usually two stages), with an alkali extraction washing stage between. On occasions oxygen is also used. Bleach plant chemicals are usually prepared in the mill so solutions such as chlorine water, sulfuric acid, sodium chlorate, sodium chloride, sodium hydroxide, calcium hypochlorite, and chlorine dioxide all have to be pumped.

It cannot be emphasized too strongly that materials of construction are of vital importance in the chemical preparation area of the bleach plant.

In addition to the standard chemicals, some of the common pulp mill bleach substances, together with some chemical preparation systems, are as follows.

**CHLORINE** This is usually delivered to the mill in tank cars but is always vaporized to a gas before use.

**CHLORINE WATER (HYPOCHLOROUS AND HYDROCHLORIC ACID)** Concentrations cover the range from pH 2 to 10 for bleaching pulp. In some cases, the gas is mixed directly with pulp in special mixers. Group C lined pumps are essential.

**SODIUM HYPOCHLORITE AND CALCIUM HYPOCHLORITE** This mixture is made in the mill by permitting chlorine to react with either sodium or calcium hydroxide concentrated caustic (70%) diluted to 5 to 6% before chlorination. Calcium hypochlorite is made from a 10% solution of slaked lime at temperatures up to 150°F (66°C), but not normally exceeding 70°F (21°C). These liquors are corrosive to steel, and group C or lined pumps are necessary when handling solutions to the bleach plant; *after* bleaching the filtrate may still have residual hydrochloric acid.

**CHLORINE DIOXIDE** This is the most common bleach solution used because it gives an excellent brightness to the pulp and, despite corrosion problems, is usually cheaper than other bleach solutions.

After generation of the gas, during which absolute cleanliness is vital, the gas is stripped in a packed tower as an aqueous solution and stored in plastic tanks made of special resins that resist chemical attack. In modern plants, increasing use is made of glass-reinforced plastic with selected resins for piping, valves, and pump linings. This is sometimes a cheaper alternative than the use of exotic metals, such as titanium, for pumps. Pumps must be group C, and stainless steel is not satisfactory. Solution strengths of up to 8 g/liter are used.

**SODIUM PEROXIDE AND HYDROGEN PEROXIDE** These are used for bleaching groundwood pulp. Typical solutions contain sodium silicate (5%), sodium peroxide (2%), and sulfuric acid (1.5%). The latter controls the pH of the liquor. Concentrations of bleach liquors are up to 15%. Temperatures are usually less than 90°F (32°C). Group C pumps are necessary.

**WASH LIQUORS** In general, the filtrate from bleach washing stages will exhibit at least some of the properties of the stage immediately before washing, owing to slight excesses of chemical present. Filtrates are collected in corrosion-resistant pipes and vessels, usually made from glass-reinforced plastic, and the pumps used will be either group B or C, depending on the stage in question. The filtrate from the chlorine dioxide stages should be pumped with a super austenitic stainless steel case and trim pump because the filtrate is not as corrosive as the bleach solution.

Spent acid from chemical preparation plants is also highly corrosive, and usually stainless steel is not satisfactory for use with it.

Effluent from the bleach plant, on the other hand, is usually a mixture of several liquors, and experience has shown that 317 stainless steel is a suitable material for pumps that handle it.

**CHLORINE DIOXIDE PREPARATION; SODIUM CHLORATE** Chlorine dioxide is produced by permitting sodium chlorate to react with sulfuric acid and hydrochloric acid in a vessel into

which a reducing agent such as NaCl, SO<sub>2</sub>, or methanol is introduced in controlled quantities. Sodium chlorate solutions are usually from 43 to 46%, at which strength the specific gravity is about 1.38. Stainless steel pumps may be used, but epoxy-resin-lined pumps are superior.

**FOUL CONDENSATE** This arises from the evaporation of water from black liquor at the multiple-effect evaporators, as these units flash vapor from the liquor in one stage and use this to evaporate the liquid in the next stage. The vapor when condensed contains some carry-over from the black liquor, and thus the condensate is contaminated and corrosive. When a nickel cast iron casing and stainless trim are used, group A pumps should be satisfactory. Some liquors produce very corrosive vapors, and a stainless casing pump may prove necessary. Group B pumps are recommended.

**Stock** Stock is the term applied to the suspension of cellulose fiber in water. It first appears either after grinding (in the case of mechanical pulp) or after the blow tank (in the case of chemical pulp). Stock production rates may be converted to pump flow rates with the following formula:

$$\text{Flow (USGPM)} = \frac{\text{Production (air dried short tons per day)} \times 15}{\text{Consistency (\% oven dried)}}$$

After the separation of chemicals or impurities by washing and screening, the stock is given a mechanical treatment known as either beating or refining, depending on the nature of the treatment. This enhances the sheet properties. Additives such as starch, clay fillers, alum, and size are introduced to impart special characteristics, depending on the end use of the product.

Over the range of stock in normal use, the specific gravity may be considered constant for all practical purposes, with a value equal to that of water at the appropriate temperature.

Cellulose fibers have a specific gravity slightly greater than water, and constant agitation is required to ensure that stratification does not occur in storage. Agitation, however, can also introduce air, to the detriment of the stock.

The pH of stock varies over a wide range—from as low as 1.0 during some bleaching processes to 11.0 with others. In the paper machine room, the pH of the stock will usually range from 4 to 8. Thus from a corrosion viewpoint washed stock does not usually present special problems except when high-grade bleached products are produced. Stains will be caused by iron sulfides or oxides, and therefore stainless steel must be used—frequently 304 for washed stock, but 316 or 317 within the bleach plant before washing or where bleach liquor is likely to be present with the stock.

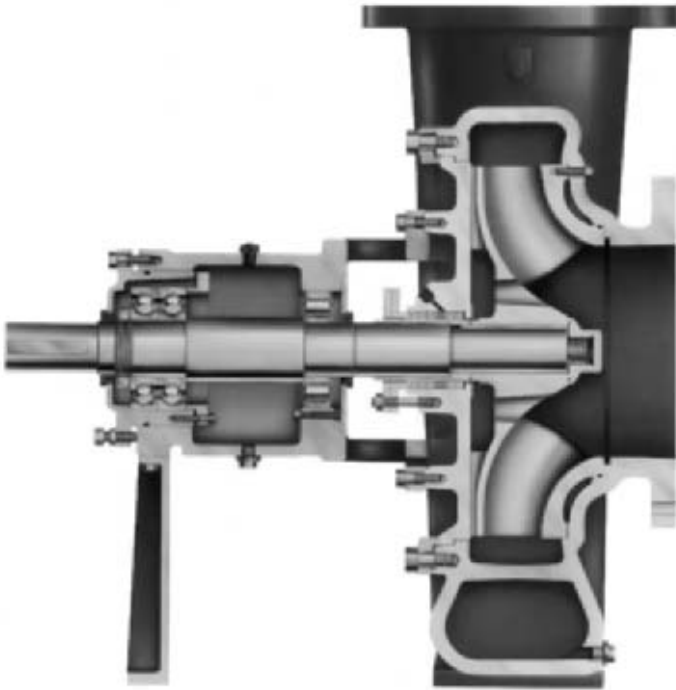
Unbleached paper mills generally do not experience corrosion with washed stock, except in the case of groundwood mills, where the pH is usually lower than in chemical pulp mills.

**FIBER CHARACTERISTICS** Stock made from softwoods will have a predominance of fibers 2.8 to 3.5 mm long and 0.25 to 0.3 mm wide; fibers from hardwoods will be about 1.0 to 1.3 mm long and 0.1 mm wide. Straw fiber will be still shorter—0.75 mm on the average—but flax can have fibers up to 9.0 mm long. These figures are typical and are of interest because of their effect on pump performance.

**CONSISTENCY** This is the amount of dry fiber content in the stock, expressed as a percentage by mass. Typical values will vary from about 0.1% for the feed to the headbox of a special paper machine to 16% for stock between some bleaching stages or in high-density towers. The critical stock consistency in the selection of pumps is 6%. Up to the 6% level, pumps may be selected on the basis of their water performance.

**FREENESS** When stock is beaten, or refined, it acquires an affinity for water, and the longer the stock is beaten, the longer the water retention period. The retention of water by the stock increases the friction factor of the flow of stock.





**FIGURE 3** End suction stock pump. (Courtesy ITT / Goulds Pumps, Inc.)

Freeness is often measured by an instrument called the Canadian standard freeness tester. The range of values covers a scale from 0 to 900, with a higher freeness value indicating a less refined stock and thus a lesser affinity for water. This instrument measures the amount of water drained from a sample of stock under a regularly decreasing head. Its use is recommended by the Technical Association of the Pulp and Paper Industry (TAPPI), and it is commonly employed in North American mills.

**STOCK PUMPS** In stock pumps, consistency is not a major problem until a value of about 6% is reached. The essential requirement is to get the stock to the pump impeller, and every effort should be made to keep the piping as large and straight as possible. A typical open impeller, end suction stock pump is shown in Figure 3.

Above 6% consistency, special pumps are required, and they can be of the positive displacement screw type or centrifugal type. Air entrainment in the stock will reduce pump output. Air entrainment occurs from agitation in the chests, from flow over weirs, and from flow through restricted openings. How air entrained in water and in stock affects pump performance is shown in Figure 6.

**PIPING ARRANGEMENT** Piping should be as straight and short as possible. This is particularly important on the suction side of the pump to prevent dewatering of the stock. The diameter of the suction piping should be at least one pipe size larger than the diameter of the pump suction and should project into the stock chest. The inlet end of the suction pipe should be cut at an angle, and the bottom of the pipe should be at least  $1\frac{1}{2}$  pipe diameters from the bottom of the chest. With the long side of the pipe on top, the probability



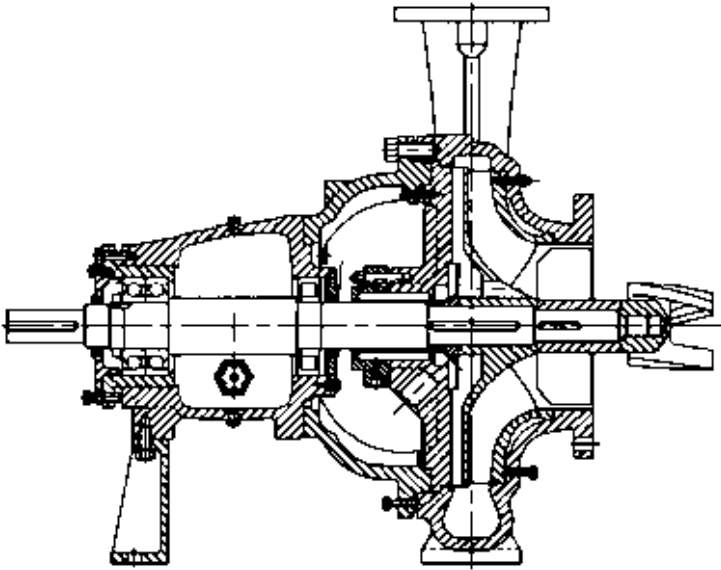


FIGURE 4 Medium consistency stock pump. (Courtesy ITT / Goulds Pumps, Inc.)

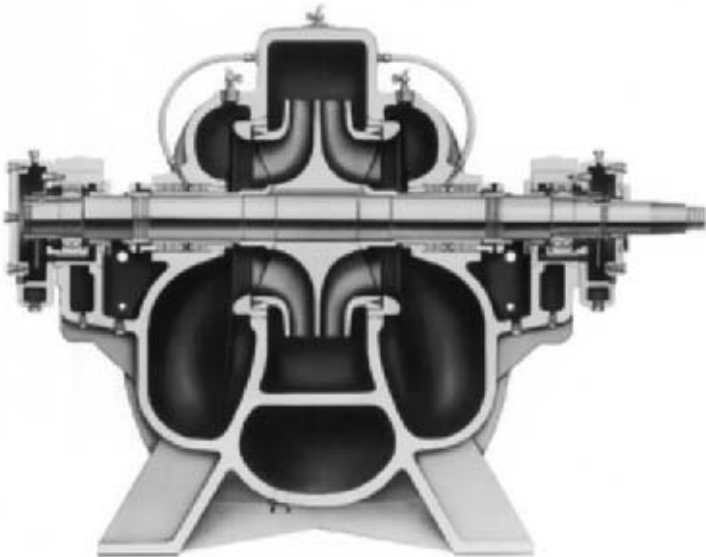


FIGURE 5 Fan pump. (Courtesy ITT / Goulds Pumps, Inc.)

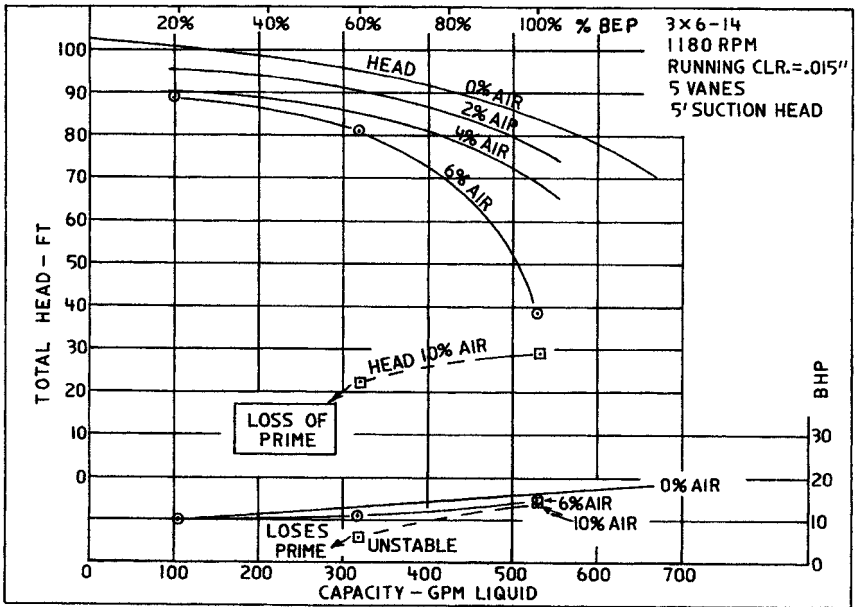


FIGURE 6 General effect of entrained gas on pump performance. (Courtesy ITT / Goulds Pumps, Inc.)

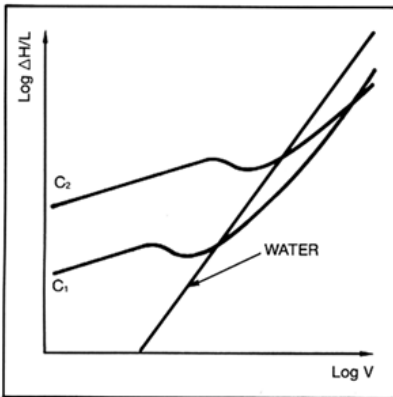
of drawing air into the suction of the pump through vortices is reduced. Some manufacturers provide a lump breaker or screw feeder at the suction side of the pump for pumping stock above from 6% to 8% consistency.

**SIZE OF PUMPS** It is important to estimate the performance requirements of stock pumps as accurately as possible. Oversizing of centrifugal pumps will cause an unbalanced radial thrust on the impeller resulting in excessive shaft deflection and reduced bearing and seal life. Oversizing can also result in impeller recirculation and the accompanying cavitation-like noise and damage to pump components.

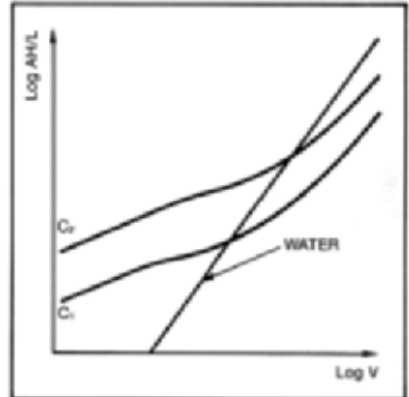
### FRICION LOSS OF PULP SUSPENSIONS IN PIPE\*

In any stock piping system, the pump provides flow and develops hydraulic pressure (head) to overcome the differential in head between two points. This total head differential consists of pressure head, static head, velocity head and total friction head produced by friction between the pulp suspension and the pipe, bends, and fittings. The total friction head is the most difficult to determine because of the complex, nonlinear nature of the friction loss curve. This curve can be affected by many factors.

\*Courtesy ITT/Goulds Pumps, Inc.



**FIGURE 7** Friction loss curves for chemical pulp ( $C_2 > C_1$ ). (Courtesy ITT / Goulds Pumps, Inc.)



**FIGURE 8** Friction loss curves for mechanical pulp ( $C_2 > C_1$ ). (Courtesy ITT / Goulds Pumps, Inc.)

The following analytical method for determining pipe friction loss is based on the recently published TAPPI Technical Information Sheet (TIS) 408-4 (Reference 1), and is applicable to stock consistencies (oven-dried) from 2 to 6 percent. Normally, stock consistencies of less than 2% (oven-dried) are considered to have the same friction loss characteristic as water.

The friction loss of pulp suspensions in pipe, as presented here, is intended to supersede the various methods previously issued.

Figure 7 and Figure 8 show typical friction loss curves for two different consistencies ( $C_2 > C_1$ ) of chemical pulp and mechanical pulp, respectively.

The friction loss curve for chemical pulp can be conveniently divided into three regions, as illustrated by the shaded areas of Figure 9.

These regions may be described as follows:

**Region 1** (Curve AB) is a linear region where friction loss for a given pulp is a function of consistency, velocity, and pipe diameter. The velocity of the upper limit of this linear region (Point B) is designed  $V_{\max}$ .

**Region 2** (Curve BCD) shows an initial decrease in friction loss (to Point C) after which the friction loss again increases. The intersection of the pulp friction loss curve and the water friction loss curve (Point D) is termed the onset of drag reduction. The velocity at this point is designated  $V_w$ .

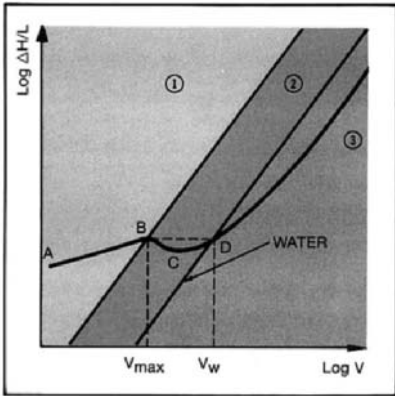
**Region 3** (Curve DE) shows the friction loss curve for pulp fiber suspensions below the water curve. This is due to a phenomenon called drag reduction. Reference 2 describes the mechanisms which occur in this region.

Regions 2 and 3 are separated by the friction loss curve for water, which is a straight line with a slope approximately equal to 2.

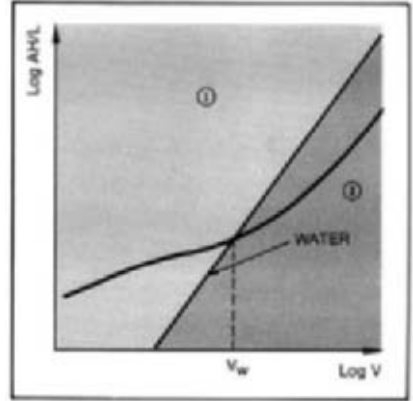
The friction loss curve for mechanical pulp, as illustrated in Figure 10, is divided into only two regions:

*Regions 1 and 3.* For this pulp type, the friction loss curve crosses the water curve at  $V_w$  and there is no true  $V_{\max}$ .

To determine the pipe friction loss component for a specified design basis (usually daily mass flow rate), the following parameters must be defined:



**FIGURE 9** Friction loss curves for chemical pulp, shaded to show individual regions. (Courtesy IIT / Goulds Pumps, Inc.)



**FIGURE 10** Friction loss curves for mechanical pulp, shaded to show individual regions. (Courtesy IIT / Goulds Pumps, Inc.)

- a) Pulp Type** Chemical or mechanical pulp, long or short fibered, never dried or dried and reslurried, etc. This is required to choose the proper coefficients which define the pulp friction curve.
- b) Consistency,  $C$  (oven-dried)** Often a design constraint in an existing system. *Note:* If air-dried consistency is known, multiply by 0.9 to convert to oven-dried consistency.
- c) Internal pipe diameter,  $D$**  Lowering  $D$  reduces initial capital investment, but increases pump operating costs. Once the pipe diameter is selected, it fixes the velocity for a prespecified mass flow rate.
- d) Bulk velocity,  $V$**  Usually based on a prespecified daily mass flow rate. Note that both  $V$  and  $D$  are interdependent for a constant mass flow rate.
- e) Stock temperature,  $T$**  Required to adjust for the effect of changes in viscosity of water (the suspending medium) on pipe friction loss
- f) Freeness** Used to indicate the degree of refining or to define the pulp for comparison purposes
- g) Pipe material** Important to specify design correlations and compare design values

The bulk velocity ( $V$ ) will depend on the daily mass flow rate and the pipe diameter ( $D$ ) selected. The final value of  $V$  can be optimized to give the lowest capital investment and operating cost with due consideration of future demands or possible system expansion.

The bulk velocity will fall into one of the regions previously discussed. Once it has been determined in which region the design velocity will occur, the appropriate correlations for determining pipe friction loss value(s) may be selected. The following describes the procedure to be used for estimating pipe friction loss in each of the regions.

**Region 1** The upper limit of Region 1 in Figure 9 (Point B) is designated  $V_{max}$ . The value of  $V_{max}$  is determined using Eq. 1 and data given in Table I or IA.

$$V_{max} = K' C^{\sigma} (\text{ft/s}), \quad (1)$$

where  $K'$  = numerical coefficient (constant for a given pulp is attained from Table I or IA)

$C$  = consistency (oven-dried, expressed as a percentage, not decimally)

$\sigma$  = exponent (constant for a given pulp), obtained from Table I or IA

If the proposed design velocity ( $V$ ) is less than  $V_{\max}$ , the value of flow resistance ( $\Delta H/L$ ) may be calculated using Eq. 2 and data given in Table II or IIA, and the appendices.

$$H/L = FKV^\alpha C^\beta D^\gamma \text{ (ft/100 ft)} \quad (2)$$

where  $F$  = factor to correct for temperature, pipe roughness, pulp type, freeness, or safety factor (refer to Appendix D)

$K$  = numerical coefficient (constant for a given pulp), obtained from Table II or IIA

$V$  = bulk velocity (ft/s)

$C$  = consistency (ven-dried, expressed as a percentage, not decimally)

$D$  = pipe inside diameter (in)

$\alpha, \beta, \gamma$  = exponents (constant for a given pulp), obtained from Table II or IIA

For mechanical pumps, there is no true  $V_{\max}$ . The upper limit of the correlation equation (Eq. 2) is also given by Eq. 1. In this case, the upper velocity is actually  $V_w$ .

**Region 2** The lower limit of Region 2 in Figure 9 (Point B) is  $V_{\max}$  and the upper limit (Point D) is  $V_w$ . The velocity of the stock at the onset of drag reduction is determined using Eq. 3.

$$V_w = 4.00C^{1.40} \text{ (ft/s)} \quad (3)$$

where  $C$  = consistency (oven-dried, expressed as a percentage, not decimally).

If  $V$  is between  $V_{\max}$  and  $V_w$ , Eq. 2 may be used to determine  $\Delta H/L$  at the maximum point ( $V_{\max}$ ). Because the system must cope with the worst flow condition,  $\Delta H/L$  at the maximum point ( $V_{\max}$ ) can be used for all design velocities between  $V_{\max}$  and  $V_w$ .

**Region 3** A conservative estimate of friction loss is obtained by using the water curve.  $(\Delta H/L)_w$  can be obtained from a Friction Factor vs. Reynolds Number plot (for example, Hydraulic Institute ANSI/HI 2000 Edition Pump Standards, Reference 3), or approximated from the following equation (based on the Blasius equation.)

$$(\Delta H/L)_w = 0.58V^{1.75}D^{-1.25} \text{ (f/100 ft)} \quad (4)$$

where  $V$  = bulk velocity (ft/s)

$D$  = pipe diameter (in)

Previously published methods for calculating pipe friction loss of pulp suspensions gave a very conservative estimate of head loss. The method just described gives a more accurate estimate of head loss due to friction, and has been used successfully in systems in North America and world-wide.

Please refer to Appendix A for equivalent equations for use with metric (SI) units. Tables I and IA are located in Appendix B; Tables II and IIA are located in Appendix C. Pertinent equations, in addition to those herein presented, are located in Appendix D. Example problems are located in Appendix E.

The friction head loss of pulp suspensions in bands and fittings may be determined from the basic equation for head loss, Eq. 5.

$$H = KV_1^2/2g \text{ (ft)} \quad (5)$$

where  $K$  = loss coefficient for a given fitting

$V_1$  = inlet velocity (ft/s)

$g$  = acceleration due to gravity (32.2 ft/s<sup>2</sup>)

Values of  $K$  for the flow of water through various types of bends and fittings are tabulated in numerous reference sources (for example, Hydraulic Institute ANSI/HI 2000 Edition Pump Standards, Reference 3). The loss coefficient for valves may be obtained from the valve manufacturer.

The loss coefficient for pulp suspensions in a given bend or fitting generally exceeds the loss coefficient for water in the same bend or fitting. As an approximate rule, the loss coefficient ( $K$ ) increases 20 percent for each 1 percent increase in oven-dried stock consistency. Please note that this is an approximation; actual values of  $K$  may differ, depending on the type of bend or fitting under consideration (4).

**Appendix A** When metric (S/I) units are utilized, the following replace the corresponding equations in the main text.

$$V_{\max} = K' C^{\sigma} \quad (\text{m/s}) \quad (1M)$$

where  $K$  = numerical coefficient (constant for a given pulp), obtained from table I or IA  
 $C$  = consistency (oven-dried, expressed as a percentage, not decimally)  
 $\sigma$  = exponent (constant for a given pulp), obtained from Table I or IA

$$\Delta H/L = FKV^{\alpha} C^{\beta} D^{\gamma} \quad (\text{m}/100 \text{ m}) \quad (2M)$$

where  $F$  = factor to correct for temperature, pipe roughness, pulp type, freeness, or safety factor (refer to Appendix D)  
 $K$  = numerical coefficient (constant for a given pulp), obtained from Table II or IIA  
 $V$  = bulk velocity (m/s)  
 $C$  = consistency (oven-dried, expressed as a percentage, not decimally)  
 $D$  = pipe inside diameter (mm)  
 $\alpha, \beta, \gamma$  = exponents (constant for a given pulp), obtained from Table II or IIA

$$V_w = 1.22C^{1.40} \quad (\text{m/s}) \quad (3M)$$

where  $C$  = consistency (oven-dried, expressed as a percentage, not decimally).

$$(\Delta H/L)_w = 264V^{1.75} D^{-1.25} \quad (\text{m}/100\text{m}) \quad (4M)$$

where  $V$  = bulk velocity (m/s)  
 $D$  = pipe inside diameter (mm)

$$H - KV_1^2/2g \quad (\text{m}) \quad (5M)$$

where  $K$  = loss coefficient for a given fitting  
 $V_1$  = inlet velocity (m/s)  
 $g$  = acceleration due to gravity (9.81 m/s<sup>2</sup>)

## Appendix B

**TABLE I** Data for use with Eq. 1 or Eq. 1M to determine velocity limit,  $V_{\max}^{(1)}$ 

Pulp Type	Pipe Material	$K'$	$\sigma$
Unbeaten aspen sulfite never dried	Stainless Steel	0.85 (0.26)	1.6
Long fibered kraft never dried CSF = 725 <sup>(6)</sup>	PVC	0.98 (0.3)	1.85
	Stainless Steel	0.89 (0.27)	1.5
Long fibered kraft never dried CSF = 650 <sup>(6)</sup>	PVC	0.85 (0.26)	1.9
Long fibered kraft never dried CSF = 550 <sup>(6)</sup>	PVC	0.75 (0.23)	1.65
Long fibered kraft never dried CSF = 260 <sup>(6)</sup>	PVC	0.75 (0.23)	1.8
Bleached kraft never dried and reslurried <sup>(6)</sup>	PVC	0.79 (0.24)	1.5
	Stainless Steel	0.59 (0.18)	1.45
Long fibered kraft never dried and reslurried <sup>(6)</sup>	PVC	0.49 (0.15)	1.8
Kraft birch dried and reslurried <sup>(6)</sup>	PVC	0.69 (0.21)	1.3
Stone groundwood CSF = 114	PVC	4.0 (1.22)	1.40
Refiner groundwood CSF = 150	PVC	4.0 (1.22)	1.40
Newsprint broke CSF = 75	PVC	4.0 (1.22)	1.40
Refiner groundwood (hardboard)	PVC	4.0 (1.22)	1.40
Refiner groundwood (insulating board)	PVC	4.0 (1.22)	1.40
Hardwood NSSC CSF = 620	PVC	0.59 (0.18)	1.8

**Notes:**

1. When metric (SI) units are utilized, use the value of  $K'$  given in parentheses. When the metric values are used, diameter ( $D$ ) must be in millimeters (mm) and velocity ( $V$ ) in meters per second (m/s).
2. Original data obtained in stainless steel and PVC pipe. PVC is taken to be hydraulically smooth pipe.
3. Stainless steel may be hydraulically smooth although some manufacturing processes may destroy the surface and hydraulic smoothness is lost.
4. For cast iron and galvanized pipe, the  $K'$  values will be reduced. No systematic data are available for the effects of surface roughness.
5. If pulps are not identical to those shown, some engineering judgment is required.
6. Wood is New Zealand Kraft pulp.

**TABLE IA** Data (5, 6) for use with Eq. 1 or Eq. 1M to determine velocity limit,  $V_{\max}$ 

Pulp Type <sup>(5)</sup>	Pipe Material	$K'$	$\sigma$
Unbleached sulphite	Copper	0.98 (0.3)	1.2
Bleached sulphite	Copper	0.98 (0.3)	1.2
Kraft	Copper	0.98 (0.3)	1.2
Bleached straw	Copper	0.98 (0.3)	1.2
Unbleached straw	Copper	0.98 (0.3)	1.2

Estimates for other pulps based on published literature.

Pulp Type <sup>(5, 6)</sup>	Pipe Material	$K'$	$\sigma$
Cooked groundwood	Copper	0.75 (0.23)	1.8
Soda	Steel	4.0 (1.22)	1.4

**Note:** When metric (SI) units are utilized, use the value of  $K'$  given in parentheses. When the metric values are used, diameter ( $D$ ) must be in millimeters (mm) and velocity ( $V$ ) in meters per second (m/s).

## Appendix C

TABLE II Data for use with Eq. 2 or Eq. 2M to determine head loss,  $\Delta H/L$ <sup>(1)</sup>

Pulp Type	$K$	$\alpha$	$\beta$	$y$
Unbeaten aspen sulfite never dried	5.30 (235)	0.36	2.14	-1.04
Long fibered kraft never dried CSF = 725 <sup>(5)</sup>	11.80 (1301)	0.31	1.81	-1.34
Long fibered kraft never dried CSF = 650 <sup>(5)</sup>	11.30 (1246)	0.31	1.81	-1.34
Long fibered kraft never dried CSF = 550 <sup>(5)</sup>	12.10 (1334)	0.31	1.81	-1.34
Long fibered kraft never dried CSF = 260 <sup>(5)</sup>	17.00 (1874)	0.31	1.81	-1.34
Bleached kraft bleached and reslurried <sup>(5)</sup>	8.80 (970)	0.31	1.81	-1.34
Long fibered kraft dried and reslurried <sup>(5)</sup>	9.40 (1036)	0.31	1.81	-1.34
Kraft birch dried and reslurried <sup>(5)</sup>	5.20 (236)	0.27	1.78	-1.08
Stone groundwood CSF = 114	3.81 (82)	0.27	2.37	-0.85
Refiner groundwood CSF = 150	3.40 (143)	0.18	2.34	-1.09
Newspaper broke CSF = 75	5.19 (113)	0.36	1.91	-0.82
Refiner groundwood CSF (hardboard)	2.30 (196)	0.23	2.21	-1.29
Refiner groundwood CSF (insulating board)	1.40 (87)	0.32	2.19	-1.16
Hardwood NSSF CSF = 620	4.56 (369)	0.43	2.31	-1.20

## Notes:

1. When metric (SI) units are utilized, use the value of  $K'$  given in parentheses. When the metric values are used, diameter ( $D$ ) must be in millimeters (mm) and velocity ( $V$ ) in meters per second (m/s).
2. Original data obtained in stainless steel and PVC pipe (7, 8, 9).
3. No safety factors are included in the above correlations.
4. The friction loss depends considerably on the condition of the inside of the pipe surface (10).
5. Wood is New Zealand Kraft pulp.

TABLE IIA Data<sup>(5,6)</sup> for use with Eq. 2 or Eq. 2M to determine head loss,  $\Delta H/L$ 

Pulp Type <sup>(5)</sup>	$K$	$\alpha$	$\beta$	$y$
Unbleached sulfite	12.69 (1438)	0.36	1.89	-1.33
Bleached sulfite	11.40 (1291)	0.36	1.89	-1.33
Kraft	11.40 (1291)	0.36	1.89	-1.33
Bleached straw	11.40 (1291)	0.36	1.89	-1.33
Unbleached straw	5.70 (646)	0.36	1.89	-1.33

Estimates for other pulps based on published literature.

Pulp Type <sup>(5,6)</sup>	$K$	$\alpha$	$\beta$	$y$
Cooked groundwood	6.20 (501)	0.43	2.13	-1.20
Soda	6.50 (288)	0.36	1.85	-1.04

**Note:** When metric (SI) units are utilized, use the value of  $K'$  given in parentheses. When the metric values are used, diameter ( $D$ ) must be in millimeters (mm) and velocity ( $V$ ) in meters per second (m/s).

## Appendix D

The following gives supplemental information to that where I.P.D. mill capacity (metric tons per day), provided in the main text.



1. Capacity (flow),  $Q$ —

$$Q = \frac{16.65(\text{T.P.D.})}{C} (\text{U.S. GPM}), \quad (\text{i})$$

where T.P.D. = mill capacity (short tons per day)

$C$  = consistency (oven-dried, expressed as a percentage, *not* decimally)

If SI units are used, the following would apply:

$$Q = \frac{1.157(10^{-3})(\text{T.P.D.})}{C} (\text{m}^3/\text{s}) \quad (\text{iiM})$$

where T.P.D. = mill capacity (metric tons per day)

$C$  = consistency (oven-dried, expressed as a percentage, *not* decimally)

2. Bulk velocity,  $V$ —

$$V = \frac{0.321Q}{A} (\text{ft/s}) \quad (\text{ii})$$

or

$$V = \frac{0.4085Q}{D^2} (\text{ft/s}) \quad (\text{ii})$$

where  $Q$  = capacity (U.S. GPM)

$A$  = inside area of pipe ( $\text{in}^2$ )

$D$  = inside diameter of pipe (in)

The following would apply if SI units are used:

$$V = \frac{1(10^6)Q}{A} (\text{m/s}) \quad (\text{iiM})$$

or

$$V = \frac{1.273(10^6)Q}{D^2} (\text{m/s}) \quad (\text{iiM})$$

where  $Q$  = capacity ( $\text{m}^3/\text{s}$ )

$A$  = inside area of pipe ( $\text{mm}^2$ )

$D$  = inside diameter of pipe (mm)

3. Multiplication Factor,  $F$  (included in Eq. 2)—

$$F = F_1 \cdot F_2 \cdot F_3 \cdot F_4 \cdot F_5 \quad (\text{iv})$$

where  $F_1$  = correction factor for temperature. Friction loss calculations are normally based on a reference pulp temperature of 95°F (35°C). The flow resistance may be increased or decreased by 1 percent for each 1.8°F (1°C) below or above 95°F (35°C), respectively. This may be expressed as follows:

$$F_1 = 1.528 - 0.00556T_1 \quad (\text{v})$$

where  $T$  = pulp temperature ( $^{\circ}\text{F}$ ), or

$$F_1 = 1.35 - 0.01T_1 \quad (\text{vM})$$

where  $T$  = pulp temperature ( $^{\circ}\text{C}$ )

$F_2$  = correction factor for pipe roughness. This factor may vary due to manufacturing processes of the piping, surface roughness, age, etc. Typical values for PVC and stainless steel piping are listed below:

$F_2 = 1.0$  for PVC piping

$F_2 = 1.25$  for stainless steel piping

Please note that the previous values are typical values; experience and/or additional data may modify the factors.

$F_3$  = correction factor for pulp type. Typical values are listed below:

$F_3 = 1.0$  for pulps that have never been dried and reslurried

$F_3 = 0.8$  for pulps that have been dried and reslurried

*Note:* This factor has been incorporated in the numerical coefficient,  $K$ , for the pulps listed in Table II. When using Table II,  $F_3$  should *not* be used.

$F_4$  = correction factor for beating. Data have shown that progressive beating causes, initially, a small decrease in friction loss, followed by a substantial increase. For a kraft pine pulp initially at 725 CSF and  $F_4 = 1.0$ , beating caused the freeness to decrease to 636 CSF and  $F_4$  to decrease to 0.96. Progressive beating decreased the freeness to 300 CSF and increased  $F_4$  to 1.37 (see  $K$  values in Table II). Some engineering judgment may be required.

$F_5$  = design safety factor. This is usually specified by company policy with consideration given to future requirements.

## Appendix E

The following are three examples which illustrate the method for determination of pipe friction loss in each of the three regions shown in Figure 9.

**EXAMPLE 1** Determine the friction loss (per 100 ft of pipe) for 1000 U.S. GPM of 4.5% oven-dried unbeaten aspen sulfite stock, never dried, in 8 in schedule 40 stainless steel pipe (pipe inside diameter = 7.981 in). Assume the pulp temperature to be  $95^{\circ}\text{F}$ .

*Solution:*

**a.** The bulk velocity,  $V$ , is

$$V = \frac{0.4085 Q}{D^2} \quad (\text{ii})$$

and  $Q$  = flow = 1000 U.S. GPM

$D$  = pipe inside diameter = 7.981 in

$$V = \frac{0.4085 (1000)}{7.981^2} = 6.41 \text{ ft/s} \quad ()$$

**b.** It must be determined in which region (1, 2, or 3) this velocity falls. Therefore, the next step is to determine the velocity at the upper limit of the linear region,  $V_{\max}$ .

$$V_{\max} = K' C \sigma \quad (1)$$

and  $K'$  = numerical coefficient = 0.85 (from Appendix B, Table I)

$C$  = consistency = 45%

$\sigma$  = exponent = 1.6 (from Appendix B, Table I)

$$V_{\max} = 0.85(4.5^{1.6}) = 9.43 \text{ ft/s}$$

- c. Since  $V_{\max}$  exceeds  $V$ , the friction loss,  $\Delta H/L$ , falls within the linear region, Region 1. The friction loss is given by the correlation:

$$\Delta H/L = FKV^{\sigma}C^{\beta}D^{\gamma} \quad (2)$$

and  $F$  = correction factor =  $F_1 \cdot F_2 \cdot F_3 \cdot F_4 \cdot F_5$

$F_1$  = correction factor for pulp temperature. Since the pulp temperature is 95°F

$$F_1 = 1.0$$

$F_2$  = correction factor for pipe roughness. For stainless steel pipe,

$$F_2 = 1.25 \text{ (from Appendix D)}$$

$F_3$  = correction factor for pulp type. Numerical coefficients for this pulp are contained in Appendix C, Table II, and have already incorporated this factor.

$F_4$  = correction factor for beating. No additional beating has taken place, therefore

$$F_4 = 1.0 \text{ (from Appendix D)}$$

$F_5$  = design safety factor. This has been assumed to be unity.

$$F_5 = 1.0.$$

$$F = (1.0)(1.25)(1.0)(1.0)(1.0) = 1.25$$

$K$  = numerical coefficient = 5.30 (from Appendix C, Table II)

$\sigma, \beta, \gamma$  = exponents = 0.36, 2.14, and  $-1.04$ , respectively (from Appendix C, Table II)

$V, C, D$  have been evaluated previously.

$$\begin{aligned} \Delta H/L &= (1.25)(5.30)(6.41^{0.36})(4.5^{2.14})(7.981^{-1.04}) \\ &= (1.25)(5.30)(1.952)(25.0)(0.1153) \\ &= 37.28 \text{ ft head loss/100 ft of pipe} \end{aligned}$$

This is a rather substantial head loss, but may be acceptable for short piping runs. In a large system, the economics of initial piping costs versus power costs should be weighed, however, before using piping which gives a friction loss of this magnitude.

**EXAMPLE 2** Determine the friction loss (per 100 ft of pipe) of 2500 U.S. GPM of 3% oven-dried bleached kraft pine, dried and reslurried, in 12 in schedule 10 stainless steel pipe (pipe inside diameter = 12.39 in). Stock temperature is 1250°F.

*Solution:*

- a.  $V$ , the bulk velocity, is

$$\begin{aligned} V &= \frac{0.4085 Q}{D^2} \quad (ii) \\ &= \frac{0.4085(2500)}{12.39^2} = 6.65 \text{ ft/s} \end{aligned}$$

- b. The velocity at the upper limit of the linear region,  $V_{\max}$ , is

$$V_{\max} = K' C^{\sigma} \quad (1)$$

- and  $K' = 0.59$  (from Appendix B, Table I)  
 $C = 3.0$  (from Appendix B, Table I)  
 $\sigma = 1.45$  (from Appendix B, Table 1)  
 $V_{\max} = 0.59 (3.0^{1.45}) = 2.90$  ft/s

- c. Region 1 (the linear region) has been eliminated, since the bulk velocity,  $V$ , exceeds  $V_{\max}$ . The next step requires calculation of  $V_w$ .

$$\begin{aligned} V_w &= 4.00 C^{1.40} \\ &= 4.00(3.0^{1.40}) = 18.62 \text{ ft/s} \end{aligned} \quad (3)$$

- d.  $V$  exceeds  $V_{\max}$ , but is less than  $V_w$ , indicating that it falls in Region 2. The friction loss in this region is calculated by substituting  $V_{\max}$  into the equation for head loss, Eq. 2.

$$\Delta H/L = F K (V_{\max})^\alpha C^\beta D^y$$

and  $F_1 \cdot F_2 \cdot F_3 \cdot F_4 \cdot F_5$  (iv)

$$F_1 = 1.528 - 0.00556T \quad (v)$$

and  $T =$  stock temperature  $= 125^\circ\text{F}$

$$F_1 = 1.58 - 0.00556(125) = 0.833$$

$$F_2 = 1.25 \text{ (from Appendix D)}$$

$$F_3 = F_4 = F_5 = 1.0$$

$$F = 0.833(1.25)(1.0) = 1.041$$

$$K = 8.80 \text{ (from Appendix C, Table II)}$$

$\alpha, \beta, y = 0.31, 1.81, \text{ and } -1.34$ , respectively (from Appendix C, Table II)

$V_{\max}, C$ , and  $D$  have been defined previously.

$$\begin{aligned} \Delta H/L &= 1.041(8.80)(2.90^{0.31})(3.0^{1.81})(12.39^{-1.34}) \\ &= 1.041(8.80)(1.391)(7.304)(0.03430) \\ &= 3.19 \text{ ft head loss/100 ft of pipe} \end{aligned}$$

EXAMPLE 3 Determine the friction loss (per 100 ft of pipe) for 2% oven-dried bleached kraft pine, dried and reslurried, through 6 in schedule 40 stainless steel pipe (inside diameter = 6.065 in). The pulp temperature is  $90^\circ\text{F}$ ; the flow rate 1100 U.S. GPM.

*Solution:*

- a. The bulk velocity is

$$\begin{aligned} V &= \frac{0.4085 Q}{D^2} \\ &= \frac{0.4085(1100)}{6.065^2} = 12.22 \text{ ft/s} \end{aligned} \quad (ii)$$

- b. It must be determined in which region (1, 2, or 3) this velocity falls. To obtain an initial indication, determine  $V_{\max}$ .

$$V_{\max} = K' C \sigma \quad (1)$$

and  $K' = 0.59$  (from Appendix B, Table I)

$\sigma = 1.45$  (from Appendix B, Table I)

$$V_{\max} = 0.59(2.0^{1.40}) = 1.61 \text{ ft/s}$$

- c. Since  $V$  exceeds  $V_{\max}$ , Region 1 (the linear region) is eliminated. To determine whether  $V$  lies in Region 2 or 3, the velocity at the onset of drag reduction,  $V_w$ , must be calculated.

$$\begin{aligned} V_w &= 4.00 C^{1.40} \\ &= 4.00(2.0^{1.40}) = 10.56 \text{ ft/s} \end{aligned}$$

- d.  $V$  exceeds  $V_w$ , indicating that it falls in Region 3. The friction loss is calculated as that of water flowing at the same velocity.

$$\begin{aligned} (\Delta H/L)_w &= 0.579 V^{1.75} D^{1.25} \\ &= 0.579(12.22^{1.75})(6.065^{-1.25}) \\ &= 4.85 \text{ ft head loss/100 ft of pipe} \end{aligned} \quad (4)$$

This will be a conservative estimate, as the actual friction loss curve for pulp suspensions under these conditions will be below the water curve.

## ECONOMICS AND PUMP SELECTION

The normal economic considerations of any continuous process apply equally well to pulp and paper mills, with a few points of difference. In pump installations, the improved cost figures that are possible from larger units are limited to some extent by the manufacturer's standard size units. Because the industry is capital intensive, the overriding factor in any pump installation is reliability. To achieve this, it does not necessarily follow that it is better to have two pumps installed, with one as a standby. One properly designed and serviced unit may well be better than two unknown units; this is especially true where the pump is in a portion of the process that cannot be interrupted without serious losses, either in raw materials or in quality of the finished product.

A duplication of pumps means complications in extra valves, pipework, connections for steam and viscous liquids, electric motors, cables, and starters. The result is that, in modern mills with good machinery and materials of construction, there is a strong tendency away from the duplication of pumps because of increased costs and questionable reliability. It follows that the important thing is to select the right pump and the right duty point in a particular range.

There may be several hundred pumps in a modern pulp and paper mill, but the cost of these pumps is probably less than 5% of the total equipment cost. It is unwise, therefore, to jeopardize mill reliability by compromising pump quality. Corrosion and erosion are major factors in pump life, and even with the best materials, the life of some components in severe service may be 12 months or less. Moreover, the power used by pumps is usually less than one-third of the mill demand. If one remembers that the cost of total power absorbed in a mill is only around 4%, even a 50% reduction in pump power will still be less than 1% net.

**Efficiency** The best point at which to operate a pump is, of course, its maximum efficiency, but this is not always possible, particularly in the case of stock pumps because of the wide range of process variables in most pulp and paper mills. Open impellers and excess clearances also reduce the efficiency, yet these factors are much more important in stock pumps than efficiency. Another important consideration is speed. Stock pumps should be chosen to run at as low a speed as possible to achieve stable operation, and this speed may not produce an efficient pump. The shape of the pump performance curve is

much more important than the best efficiency quoted by a manufacturer. A flat or unstable head curve may produce surging or instability in the pump output. Good pump selection, therefore, must emphasize reliability as the first consideration and efficiency and costs as secondary considerations.

**Pump Speeds** Most of the pump duties in a mill can be accomplished by single-stage pumps and four-pole motor speeds. For liquids other than water, two-pole motor speeds should be avoided if possible. For special duties, including stock pumping, six- or eight-pole motors may be required unless some indirect or variable speed is used. Although it is true that lower speeds mean larger pumps and more expensive electric motors, lower speeds are justified because of reduced maintenance and greater reliability. Some deviation from these speeds may be necessary for pumps generating heads in excess of 150 ft (46 m), but this can often be taken care of by a larger impeller rather than a higher shaft speed.

Although not an option in every circumstance, the use of variable speed drive systems for pumps to replace control valves should also be considered. Reliable alternating current variable frequency drives are now readily available up to 2300 volts and are easily justifiable based on normal power costs at the 440 volt level. The commensurate speed reduction seen by the pump when replacing a control valve and avoiding its necessary pressure drop will also add to the reliability and life of the pump.

**Multistage Pumps** Except with boiler feedwater, the use of multistage pumps should be avoided. This is particularly true for stock and viscous liquors. The complicated pump design makes such units unacceptable for these services.

**Pipeline Systems** With black liquor, green liquor, and similar high-viscosity liquors, adequate provision must be made for steaming out and subsequent liquor drainage. The pumps must also be included in this system. Although the liquor pumps should be designed to pass some solid matter, motorized strainers should be used on the pumps for cyclone evaporators and recovery boiler-fuel pumps because both pumps discharge to spray nozzles. Dead pockets and other areas where liquor can collect should be avoided because solids from the liquor will build up in these areas and possibly break away to block pipelines or pump impellers. For protection at shutdowns, even for short periods, steaming out is essential.

**Positive Displacement Pumps** The principal use of the positive displacement pump is for consistency control of stocks above 5%. The normal measuring device used is quite satisfactory at low consistencies but is less reliable at the higher values. More satisfactory control may be achieved by using a screw pump, where the power is proportional to the pulp consistency at constant flow. Such pumps have been very reliable on consistency control.

**Digester Circulating Pumps** Digester circulating pumps are used with indirectly heated batch digesters to circulate the liquor at the digester pressure and temperature. Maintenance problems are common on these pumps because heads can be as high as 150 lb/in<sup>2</sup> (1034 kPa) and temperatures as high as 350°F (177°C). In addition, the circulating liquor contains some raw pulp even though screens are fitted to the digester outlets. Pumps for this service, therefore, should be centerline mounted, of very heavy construction, have closed impellers, and mechanical seals. In addition, there is often considerable pipework involved, for a digester may easily be 60 ft (18 m) high and pipe loads are often imposed on the pumps. Expansion joints and long-radius bends are used, but it is desirable to support the pumps on springs or slide bases.

**Pumps for Heavy Black Liquor Above 60% Solids** A typical pump for this service is shown in Figure 11. An open impeller in a 316 stainless steel casing is recommended. A heavy sleeved shaft of 316 stainless steel with ample clearance between the rotating parts is also required for satisfactory operation. These pumps may be required to handle black liquor up to 2000 centistokes viscosity and should be provided with water cooling. Steam

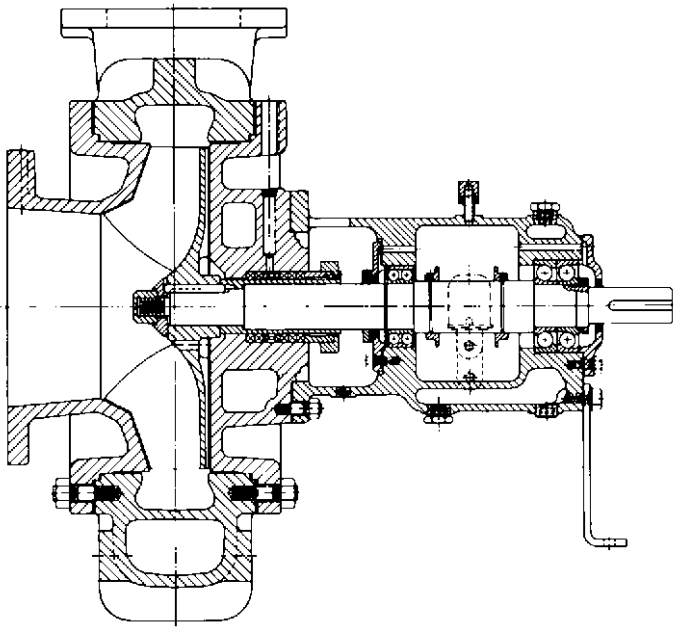


FIGURE 11 Black liquor pump (Courtesy ITT/Goulds Pumps, Inc.)

jacketing is not always satisfactory because the liquor may tend to bake on the walls of the casing. Pump speeds should be below 1800 rpm, if possible.

**Multiple-Effect Evaporator Pumps** Pumps in this service often operate in cavitation owing to problems in regulating the flow between evaporation stages. Level control valves in the suction line to the pump can alleviate this problem, but cavitation can still be expected in the pump. A self-priming pump may give longer life of the rotating elements than the condensate pump usually used on this service.

**Diaphragm Pumps** Diaphragm pumps are used in pumping lime mud slurries of high concentration. They consist of a rubber or neoprene diaphragm with a pulsating air supply on one side, controlled by a timer, and the slurry on the other.

**Medium Consistency Stock Pumps** Pumping of medium consistency stock (from about 8% to about 16% consistency) can be accomplished with positive displacement screw pumps or centrifugal pumps that have been specially adapted. Medium consistency stock is a thick viscoelastic material made up of strong networks of fibers called flocs. A high shear rate is necessary to render the stock capable of flow. Therefore all centrifugal medium consistency pumps are equipped with an inducer or feeder vane device in front of the pump suction to provide the shear necessary for the stock to flow into the impeller eye. There are also large amounts of entrained air in medium consistency stock and most centrifugal medium consistency pumps are equipped as well with an auxiliary vacuum pump to remove the air allowing for stable pump operation and high efficiencies. An example of a medium consistency centrifugal pump is shown in Figure 4.

**Fan Pump** Another specialized pump application in the paper mill is the pump that feeds the headbox or nozzle that spreads white paper onto the moving wire sheet that

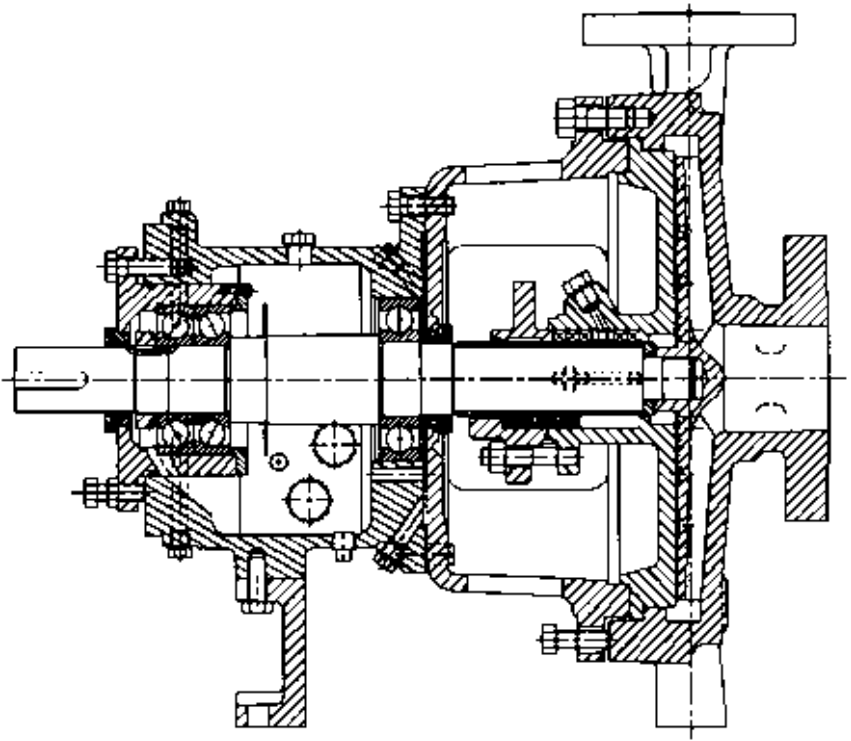


FIGURE 12 A typical low flow pump used for shower services. (new) (Courtesy ITT / Goulds Pumps, Inc.)

forms the paper. The *fan pump* is usually a large horizontally split double suction pump in austenitic (AISI 316) trim or all austenitic (AISI 316) stainless steel construction. To form an evenly distributed sheet, the headbox must be provided with flow that is free of pressure pulsations and flow disturbances. The fan pump rotating element (impeller, shaft, sleeves, and so on) is designed and built to special tolerances to guarantee a typical maximum pressure pulse of 0.5% of pump total dynamic head, peak-to-peak, at any frequency. A typical fan pump is shown in Figure 5.

**Shower Services** Shower services require pumps to operate at low flows and high pressures. Operation at low flows requires special pump designs to ensure good pump reliability. These pumps are usually of single stage design with special, circular volute construction to minimize radial loads on the rotor and bearings. A typical low flow pump is shown in Figure 12. Some high pressure shower services require multistage or high speed (greater than 3600 rpm) pumps to reach the desired pressure. Generally, multistage and high speed pumps require more maintenance than single stage units because of mechanical complexity.

**Solid Handling Services** There are many pump applications that require handling of various size solids, particularly in recycle services. Recycle services may contain tramp metal and plastics that can clog stock pumps. Recessed impeller pumps, sometimes referred to as vortex pumps, are particularly useful for these types of services because the impeller is recessed from the main flow allowing large solids to pass through the pump.



**Sealless Pump Services** In recent years, some of the severely corrosive chemical applications have been served well by sealless pumps. Magnetic drive pumps are particularly useful for tank car unloading or sodium hydroxide and other chemicals where mechanical seals have required high levels of maintenance (See Section 2.7).

**Vacuum Pumps** These are used to extract water from the sheet on the fourdrinier wire and at the suction presses by means of a vacuum up to a maximum of about 25 inHg (635 mmHg). Approximately 40,000 lb (18,100 kg) of water is extracted by this means for every ton (1000 kg) of paper produced, and this water is removed by entrainment with the air handled by the vacuum pumps. Frequently water separators are used to remove water; their use is a matter of economics, as a reduction of up to 10% in power may be achieved.

Vacuum pumps are of three basic types:

1. Water ring
2. Positive displacement
3. Centrifugal or axial-flow

Many engineers prefer the water-ring type, probably because of its simplicity. In general, however, this type uses more power, mainly because of the heating of the circulating water, which is then discharged to a drain.

Centrifugal and axial-flow machines must be provided with water separators, but they are more efficient overall, particularly when the heat of compression is used in the machine room ventilating system. The machines run at high speed and are usually driven by a steam turbine.

The paper machine system requires vacuums at different levels, from a few inches (millimeters) of mercury to the maximum possible. Often pumps are connected to a common header, and orifice plates are used to divide the flow to ensure some measure of standby capacity. This involves throttling, however, and may create flow problems unless quantities are carefully estimated. The axial-flow machine permits extraction at any point along the rotor within fairly close limits and requires an accurate estimation of the quantities and specific vacuum required. A standby for axial-flow machines cannot usually be justified.

**Stock and Liquor Pump Standardization** Throughout the mill the duties of many pumps are similar, but different materials of construction may be used. If, at a slightly extra initial cost, the rotating elements of the pump can be standardized, this will reduce spare-parts inventories. This is also an advantage when purchasing pumps for a new mill. For example, if a standard arrangement consists of a complete rotating element, including bearings, only the impeller size and material need be different. Standardization is an additional reason for recommending that all pumps be stainless-steel. Obviously, large pumps need individual evaluation. Standardization of stock pumps is less feasible, but up to about 6% stock, similar pumps can usually be specified.

**Pump Selection Guidelines** In many cases, an excess margin on head and capacity is specified. Where margins are excessive, mechanical troubles and cavitation often occur. The following guidelines will help to properly size a pump and motor in order to avoid these problems:

1. Carefully calculate the pump duty, using the TAPPI technical information sheet (TIS 408-4) for stock friction and the proper viscosity corrections for liquor friction. Always use a schematic of the actual piping system to be installed.
2. Properly size control valves to minimize the required pressure drop. Consider the use of variable speed drives.
3. Make the proper corrections to head and power for the presence of entrained gas in the fluid being pumped, per pump manufacturers recommendations.

4. Select a pump from the manufacturer's curve and note the impeller diameter and range for the pump. If the duty point falls near the end of the curve or if the impeller diameter is greater than 95% of the maximum impeller diameter, it is advisable to select the next size larger pump. For maximum reliability, select an impeller diameter equal to or nearly equal to:  $\{(\text{maximum impeller diameter} - \text{minimum impeller diameter}) \times 0.75\} + \text{minimum impeller diameter}$ .
5. Allow 10% or 3 ft (whichever is larger) between *NPSHA* and *NPSHR*. Systems should be designed for a maximum available *S* value (suction specific speed) of 8,000.
6. Motors should be sized to be non-overloading for 105% of the impeller diameter chosen. Baseplates should allow for the installation of the next larger frame size.

## REFERENCES

---

1. TAPPI Technical Information Sheet (TIS) 408-4. Technical Association of the Pulp and Paper Industry, Atlanta, Georgia (1981).
2. K. Molter and G.G. Duffy, TAPPI 61, 1, 63 (1978).
3. Hydraulic Institute Engineering Data Book, 2nd Edition, 1990, Hydraulic Institute, Parsippany, NJ [www.pumps.org](http://www.pumps.org).
4. K. Molter and G. Elmqvist, TAPPI 63, 3, 101 (1980).
5. W. Brecht and H. Helte, TAPPI 333, 9, 14A (1950).
6. R. E. Durat and L. C. Jenness, TAPPI 39, 5, 277 (1956).
7. K. Molter, C. G. Duffy and Al Titchener, APPITA 26, 4, 278 (1973).
8. G. G. Duffy and A. L. Titchener, TAPPI 57, 5, 162 (1974).
9. G. G. Duffy, K. Molter, P. F. W. Lee, and S. W. A. Milne, APPITA 27, 5, 327 (1974).
10. G. G. Duffy, TAPPI 59, 8, 124 (1976).
11. G. G. Duffy, Company Communications. Goulds Pumps, Inc. (1980–1981).

---

# SECTION 9.9

---

# FOOD AND BEVERAGE PUMPING

---

JAMES L. COSTIGAN  
JOHN DRANE

## ***INDUSTRY STANDARDS***

---

Pumps for use in food, beverage, and pharmaceutical industries must meet various hygiene standards. These standards define the materials of construction and the “cleanability” of the pump. Unlike other industrial applications, pumps for the food and beverage industries must meet rigid sanitation codes, known in the industry as the “3-A” Standards\*. These standards were originally established for the dairy industry by the following organizations:

1. The International Association of Milk, Food, and Environment Sanitarians.
2. The U.S. Public Health Service.
3. The Dairy Industry Committee, composed of representatives from the following:
  - American Butter Institute
  - American Dry Milk Institute
  - Dairy and Food Industries Supply Association
  - Evaporated Milk Association
  - International Association of Ice Cream Manufacturers
  - Milk Industry Foundation
  - National Cheese Institute
  - National Creameries Association

\*Available from the International Association of Milk, Food and Environmental Sanitarians, Box 437, Shelbyville, IN 45176.

In the U.S., the 3A standards are widely enforced. They are recognized internationally, but are not enforced to the same degree. The 3A standards are a self-certifying standard, and they consider design and construction features only. They do not require microbiological testing for cleanliness.

In Europe, the "Supply of Machinery (Safety) Regulations" (1992) defines the safety and hygienic requirements for equipment to be used on agri-foodstuffs. This is legislative and is not a voluntary standard. Compliance with these regulations enables the CE Mark to be attached to the machine. Non-compliance means machines cannot be sold within the European community (EC). The European Committee for Standardization (CEN) will produce a standard (TC 197) for pumps for food use, in support of the "Machinery Regulations" that will eventually form the controlling standard for all pumps designed for food use in the EC.

An independent group, formed mainly from users of sanitary equipment (European Hygienic Equipment Design Group—EHEDG), has produced guidelines for all types of equipment, including pumps. This group acts in an advisory capacity to CEN and other standardization bodies. These guidelines are generally very onerous, but they are often specified by end users of hygienic equipment.

The principle requirements of hygienic pumps are that the wetted parts should be compatible with the products being pumped, and that the pump can be easily cleaned, either by dismantling or by clean-in-place (C.I.P.) processes. Externally, the pumps should be smooth and free from crevices where dirt could lodge and bacteria or insects could flourish.

Emerging standards issued by the American Food and Drug Authority (AFDA) and European Directives based on these standards specify suitable materials for contact with foodstuffs. They also define any restrictions that may apply to them and test methods to prove compliance. These standards are recognized internationally and are widely used.

## **PUMP DUTIES**

---

Pumps are used for filling, emptying, transferring, dosing and mixing. They are also used to convey the process fluid through plant items with a high resistance to flow, such as membrane filters and heat exchangers. In general, pumping should not harm any solids in the liquid, and delicate shear-sensitive products must be handled gently. The choice of a particular pump depends on consideration of a number of factors. These include capacity, delivery pressure, and suction conditions. The calculation of system pressure losses is discussed in Section 8.1.

It is important to consider the viscosity of the liquid at the actual shear rate and temperature appropriate for the system. Newtonian liquids have a constant viscosity with shear rate (for example, glucose). Nonnewtonian liquids such as tomato ketchup have a viscosity that is dependent on shear rate. Some liquids become less viscous with increasing shear rate; these liquids are called *thixotropic*. Examples of a thixotropic liquid are starch and molasses. Others, less commonly, become more viscous with increasing shear rate; these liquids are called *dilatant*. An example of a dilatant liquid might be some candy compounds. Most liquids also become less viscous with increasing temperatures.

The fact that viscosity changes with shear rate and temperature means that a careful assessment must be made of all fluids that we intend to pump. This assessment would normally produce three values of viscosity that must be considered in the pump and system design.

1. Viscosity in the storage tank (low shear)
2. Viscosity in the pipe work (medium shear)
3. Viscosity in the pump (high shear)

A shear-sensitive material, which will degrade with work, would normally need a positive displacement pump with low shear characteristics, pump speed being selected accordingly. If solids in the product are not to be damaged, a pump with suitable-sized spaces and

cavities must be selected. In some cases, high shear rates will be advantageous to the process (for example, mixing of emulsions) and the pump and system can be selected accordingly.

The chemistry of the liquid will determine the compatibility of the pump materials. The viscosity of the process fluid and its rheological properties affects both the speed at which the pump can run and also the friction losses to be expected within the system. The friction losses will affect the power required to run the pump. Generally, the more viscous a product, the slower the pump will need to run. If the product is very viscous, larger suction piping may be required, or in some cases, special enlarged inlets are used with auger assistance.

If the product is abrasive or carries hard solids in suspension, again pump speed will often need to be reduced to give economic life to pump components. Often, pumps with resilient components or those that do not have fixed clearances are better suited for this service. If, however, the solids in suspension are liable to settle at low speeds, speed must be increased to keep the solids in suspension to protect component life.

The product temperature may affect the suction performance capability of the pump. Also, for high fluid pumping temperatures, the pump and pumping elements must be selected to take account of differential expansion or contraction resulting from temperature variations. In some cases, pump performance is limited because of liquid properties.

## PUMP TYPES

---

Food and beverage pumps are divided into two generic types: rotodynamic and positive displacement. Both types are widely used in the food and beverage industries.

**Rotodynamic Pumps** Rotodynamic (centrifugal) pumps are widely used in hygienic applications (Figure 1) because they are simple and inexpensive, they give a smooth delivery, and they are relatively easy to clean. They are, however, limited by viscosity that will greatly reduce pump efficiency above about 500 centipoise, generally regarded as the limiting viscosity. As the pumps rely on speed of rotation to generate head, there are fairly high shear rates within the pumping elements that affect shear-sensitive products. Also, because it is not self-priming, it has a limited ability to handle entrained gases and vapors. A positive feature of centrifugal pump designs is that the performance varies according to the system operating conditions to which it is subjected. Unlike a positive displacement pump, the discharge of a centrifugal pump can be partially or fully closed without over-pressurizing the pump.



FIGURE 1 Hygienic centrifugal pump (APV Fluid Handling)

**ADVANTAGES** These pumps are simple; they are of generally robust construction; pumps are easy to clean in place; pumps cannot be over-pressurized against a closed valve; they can be connected in series for increased pressure; and they can be connected in parallel for increased flow.

**DISADVANTAGES** These pumps typically are not self-priming; they are generally limited to about 500 centipoise viscosity; they are limited ability to handle fluids that are shear-sensitive; and they have a limited ability to handle high percentages of entrained gases.

**Positive Displacement Pumps** Positive displacement pumps are used in processes where viscosity limits the capabilities of a centrifugal pump or where the process needs to be versatile and the batches vary. They are normally self-priming and can handle gaseous products. However, all positive displacement pumps require pressure relief systems to prevent damage to the pump or system if a valve is closed or the outlet blocked.

Many types of positive displacement pumps are available and they are normally split into two groups—rotary and reciprocating, the reciprocating type needing a valving system to be able to operate. Valves increase shear rates and are susceptible to wear and blockage.

### ***Gear Pumps***

**ADVANTAGES** These pumps are self-priming; there is uniform discharge with little pulsing; the pumps are reversible; due to small clearances, little flow variation with change of viscosity or pressure.

**DISADVANTAGES** They can only pump clean fluids due to fine clearances and rubbing gear teeth; they cannot run dry; they need close tolerances to operate, so fits and alignment are critical.

### ***Lobe Rotor Pumps (Figure 2)***

**ADVANTAGES** These pumps can run dry for short periods as rotors have clearance, but run-dry time is limited by the seals; pumps can self-prime on low lifts; pumps can handle solids in suspension; there is little change of product velocity as it passes through the pump, so the pump has good net positive suction head (*NPSH*) performance, once primed; pumps can generally handle viscous materials; pumps are usually reversible.

**DISADVANTAGES** Fixed clearances can mean rapid performance degradation because of abrasive wear; pump has two shafts and associated shaft seals; suction lift limited at low speed/viscosity due to clearance of rotors.

### ***Flexible Impeller Pumps (Figure 3)***

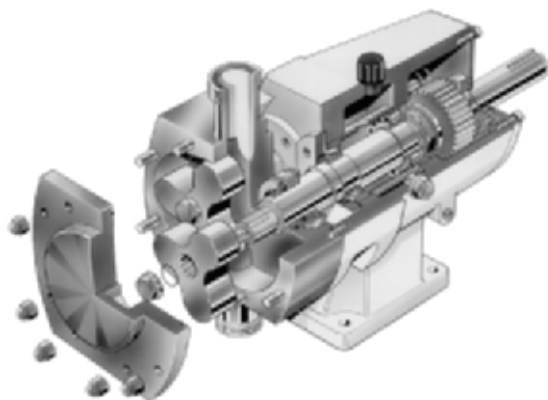
**ADVANTAGES** Pumps are generally self-priming; pumps create relatively low pressure pulsations while pumping; pumps are reversible; pumps can handle gaseous fluids and fluids with some solids in suspension; pumps are easily cleaned.

**DISADVANTAGES** Pumps cannot run dry; pumps are only suitable for low pressure applications; pumps are not suitable for abrasive services.

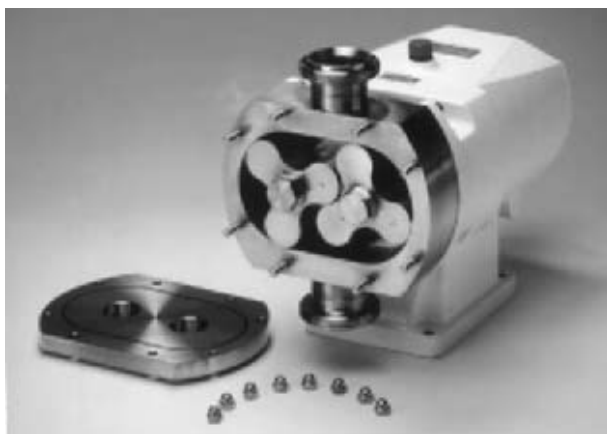
### ***Progressive Cavity Pumps (Figures 4 and 7)***

**ADVANTAGES** These pumps are self-priming; they exhibit uniform discharge with little pulsation; they are reversible and can handle gaseous fluids; they can handle solids in suspension and abrasives and can handle shear-sensitive fluids with little damage.

**DISADVANTAGES** The pumps cannot run dry.



A



B



C

**FIGURE 2A through C** Rotary lobe pumps (Alfa Laval Pumps, Ltd.)



A



B

**FIGURE 3A and B** Flexible impeller pumps (ITT/Jabsco).



A



B

**FIGURE 4A and B** Hygienic progressive cavity pumps (Mono Pumps, Ltd.)





FIGURE 5 Hygienic peristaltic pump (Watson-Marlow, Ltd.)

### ***Peristaltic Pumps (Figure 5)***

**ADVANTAGES** Pumps are self-priming; they can run dry and are reversible; they can handle gaseous fluids and can pump abrasive material and solids in suspension; they have only one contact part with no seals.

**DISADVANTAGES** Tube failure means loss of product; at low rotational speeds, pulsation can be a problem.

### ***Piston Pumps***

**ADVANTAGES** Pumps may be used for very precise dosing; pumps can handle high pressures.

**DISADVANTAGES** Pumps are not reversible; they need valves to operate; and they generally have pulsing flow.

### ***Diaphragm Pumps***

**ADVANTAGES** Pumps can run dry for short periods; they are fairly easily cleaned; and they have no glands.

**DISADVANTAGES** Pumps are not reversible; they need valves to operate; and they have pulsing flow.

**Mechanical Seals** Pumps in the food and beverage industries are almost totally fitted with mechanical seals (see Figure 6). These seals must be simple in construction and designed in such a way as to facilitate cleaning. Cleaning in place (C.I.P.) is a frequent requirement, and mechanical seals for these pumps are specifically designed for this purpose.



FIGURE 6 A hygienic mechanical seal (Roplan, Ltd.)



A

FIGURE 7A through C Typical installations of a progressive cavity hygienic pumps (Mono Pumps, Ltd.)

**Pump Drives** Standard electric motors, usually totally enclosed and fan-cooled, are used throughout the industry. A stainless steel casing is sometimes used to enclose the motor and simplify external cleanability. Pump units must be either grouted to the floor or mounted at least 2 in (50mm) above the floor to enable cleaning and eliminate any build-up of debris.

Figures 7A, B and C show typical installations of progressive cavity hygienic pumps.



B



C

---

# SECTION 9.10

---

# MINING

---

W. D. HAENTJENS

It might be asked why pumps used in mining services receive a separate classification when the types involved do not differ in principle or in general appearance from those used in fresh-water service. The answer is the need for utmost reliability and an ability to withstand both corrosive and abrasive waters. Not all mine waters are corrosive, but almost all mine waters from active mines are abrasive because of the suspended solids from the mining operations. Much can be done to limit the amount of solids handled, but the solution generally requires a compromise based on economics. Removal of most coarse solids is usually justified but removal of fine solids is generally impractical. Thus, a heavy-duty pump has evolved that warrants the classification of mine pump.

## ***PUMPING CONDITIONS AND PUMP TYPES***

---

Pumping conditions in mining services can be determined from a consideration of the types of mines and the material being mined. For example, the broadest category would be a division between open-pit and underground or deep mines. Open pit mines seldom exceed 600 ft (183 m) in depth so the pumping heads generally are not much greater than this unless very long discharge lines are required. For many open-pit mines, the greatest pumping load does not result from groundwater but from rainfall. Unless a certain increase in water level can be tolerated at the bottom of the pit, the maximum rainfall rate and the drainage area involved will determine the required pumping capacity.

As mining progresses, the pumps generally must move with the operator. This suggests the use of barge-mounted vertical pumps. A practical cost-effective way of achieving dewatering under this scenario is the use of a pond system with barge-mounted vertical cantilevered shaft pumps. Barge mounting adds a great deal of flexibility. Simple barges, as in Figure 1, illustrate the simplicity of this mounting. Except for occasional greasing of the bearings, there is little maintenance, as these pumps do not require a stuffing box or



FIGURE 1 A simple barge (Hazleton Pumps, Inc.)

mechanical seal. Almost any size can be barge mounted. Figure 2 shows one of three 1500 HP (1119 kW) vertical cantilevered shaft pumps that are installed on one barge. Each pump is rated at 14,000 gpm (3180 m<sup>3</sup>/h).

Where there is significant rainfall, the flow rates are generally large and the combination of large capacities with moderate heads may suggest a double suction pump. The selection of a double suction pump may permit the use of a higher speed pump; however, the selection may not be based on hydraulic considerations alone. An examination of hydraulic design for a double suction pump may show it is ideal for a barge-mounted vertical pump, providing there is ample water level in the pit. On the other hand, minimum water levels may be required to facilitate mining operations. If these conditions exist, which commonly occurs, selection of a top inlet single stage pump may be better. Top inlet barge mounted vertical pumps can pump the water level down without drawing the mud from the bottom. This is the conflict, as the desirable features of the double inlet pump are lost.

Comparative features can be readily seen from an examination of the net positive suction head (*NPSH*) requirements. High-capacity moderate head pumps have a specific speed ( $N_s$ ) which may require a greater *NPSH*; that is, a greater submergence. This may alter the pump length and the ability to utilize a cantilevered shaft pump. Such pumps are ideal for barge mounting if the *NPSH* (required submergence) conditions exist.

Figures 3 and 4 are reproductions of charts published by the Hydraulic Institute. An example will highlight the available design choices. Calculations may show that some combinations of flow, head, and pump speed are not feasible. This is an important consideration before proceeding with design. Assuming we have a possible floating pump station with a pumping requirement of 7500 gpm (1700 m<sup>3</sup>/h) and a calculated discharge head of 300 ft (91m), Table 1 shows the calculation of the required absolute suction conditions. Converting from absolute pressure to submergence from the water level to the impeller centerline, under standard atmospheric conditions, the table shows how much submergence is required for a given operating speed. The table shows that a single inlet pump at 1800 rpm is not practical, and a pump designed for 1200 rpm is barely acceptable. A dou-



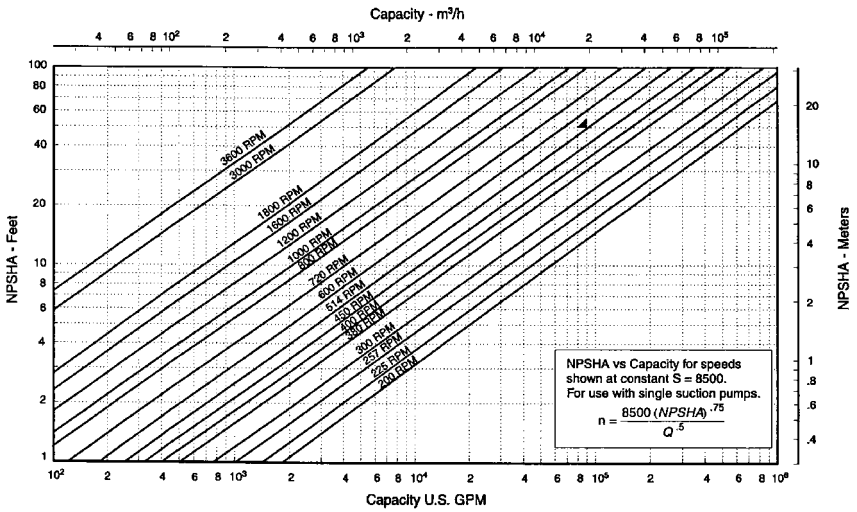
**FIGURE 2** Vertical cantilevered shaft pumps used for barge mounting (Hazleton Pumps, Inc.)

ble suction pump at 1800 rpm is also barely acceptable if there is to be a cushion for low barometer days. A double suction pump at 1200 rpm is fully acceptable. We are not locked into this selection, as a lower flow rate with more pumps may be fully acceptable at a higher speed.

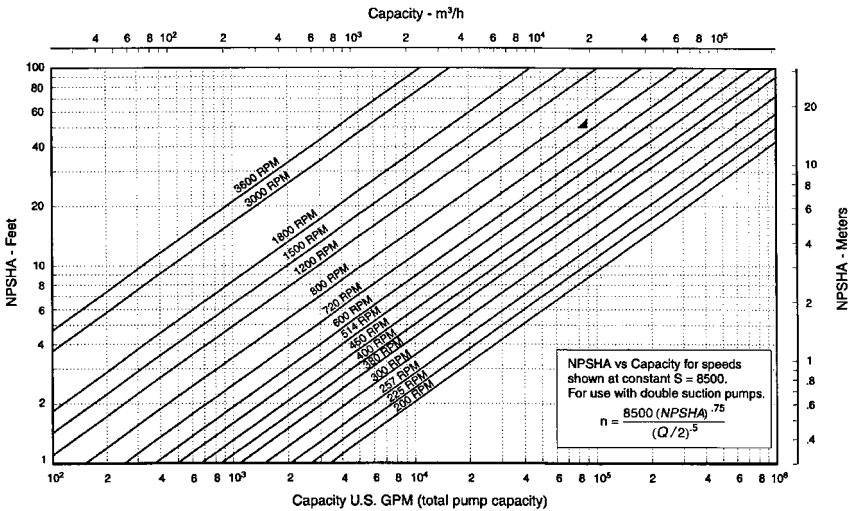
The calculation for *NPSH* shows that the 1800 rpm double suction pump and the 1200 rpm single suction pump have about the same *NPSH* requirement. Although both are for the same hydraulic conditions, they are substantially different pumps. If the *NPSH* requirements can be met with a simple single inlet higher-speed barge mounted pump installation, a substantial reduction in cost and weight is possible.

Technically, other solutions are possible when the *NPSH* is marginal. If the *NPSH* requirement is only a few additional feet, it may be possible to lengthen the pump to increase the submerged depth. In comparing available *NPSH* and required *NPSH*, the altitude of the installation and the temperature of the liquid should be considered. Altitude correction can be simply applied as 1 ft (0.3 m) for each 1000 ft (305 m) of elevation in the calculation of *NPSH* available.

The development of large overhung vertical shaft pumps has been a boon to mining operations. Figure 5 shows the installation of four floats, each with a 400 HP (300 kW) top inlet cantilevered shaft pump. The type of mining operation frequently dictates the pump design and particularly the installation. Figure 6 shows float mounted pumps designed to



**FIGURE 3** Recommended maximum operating speeds for single suction pumps (Hydraulic Institute ANSI/HI 2000 Edition Pump Standards, Reference 1)



**FIGURE 4** Recommended maximum operating speeds for double suction pumps (Hydraulic Institute ANSI/HI 2000 Edition Pump Standards, Reference 1)

skim the clean liquid in a settling pond. The float construction acts as a weir so only the cleanest liquid is returned to the plant. The float mounts 250 HP (185 kW) top inlet vertical cantilevered shaft pumps. An interesting feature is the hydraulic thrust balancing by the use of opposed flexible hose discharge lines. Note that these forces also exist in steel pipeline and must be adequately restrained.

**TABLE 1** Calculation of required absolute suction conditions

Pump Type	Operating Speed—rpm	Specific Speed	<i>NPSH</i> Required Ft (m)	Submergence Ft (m)
Single Suction*	1800	2163	48 (14.6)	18 (5.5)
Single Suction*	1200	1529	30 (9.1)	0**
Double Suction	1800	1442	31 (9.5)	1 (0.3)***
Double Suction	1200	1019	18 (5.5)	0***

\*Can be top or bottom inlet

\*\*Barely acceptable with submergence sufficient to prevent vortexing at inlet

\*\*\*Very safe



**FIGURE 5** An installation of four floats with top inlet cantilevered shaft pumps (Hazleton Pumps, Inc.)

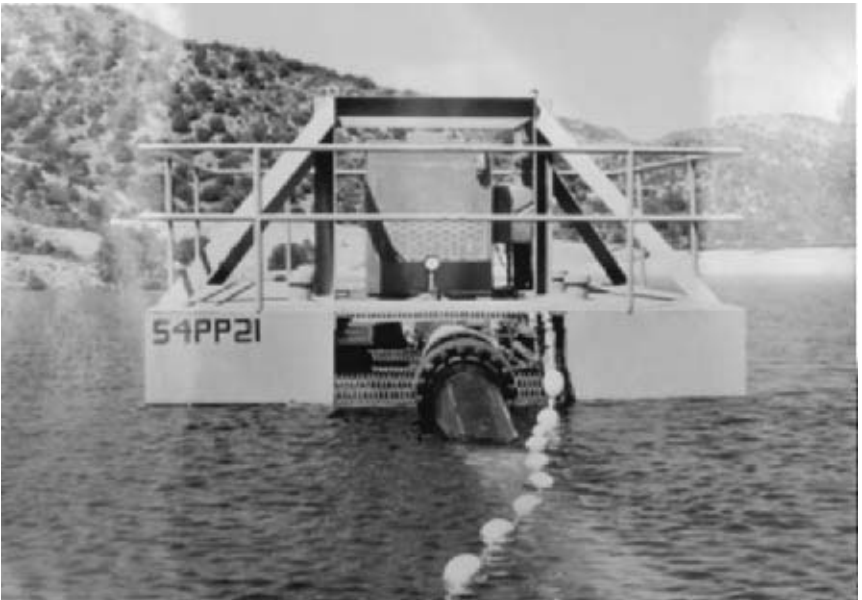
Figure 7 illustrates an interesting installation of a float-mounted pump of unique design. The pump is of cantilevered shaft design (no submerged bearings) with the pump utilizing the motor bearings. Pump construction is shown in Figure 8. This is ideal for barge mounting. It involves a special motor, but the lower center of gravity permits a smaller barge and readily compensates for the extra cost of the motor. No submerged shaft bearing is required, so dirty water can be handled with little maintenance. A double discharge design also provides balanced hydraulic side thrust and eliminates the need for a shaft seal.

If floats are to be used for pump mounting, considerations in addition to hydraulics must be examined. Floats must be designed for safe operation in all circumstances. Floats for individual pumps are simple and readily moved about a mining operation; however, there are other factors beside the weight of the pump and motor. A portion of the discharge line (usually a hose on floats) must be supported by the pump float. Consideration must be given to the possibility that a number of workmen might gather at one side of the float and overturn it. Stability calculations must be made by considering



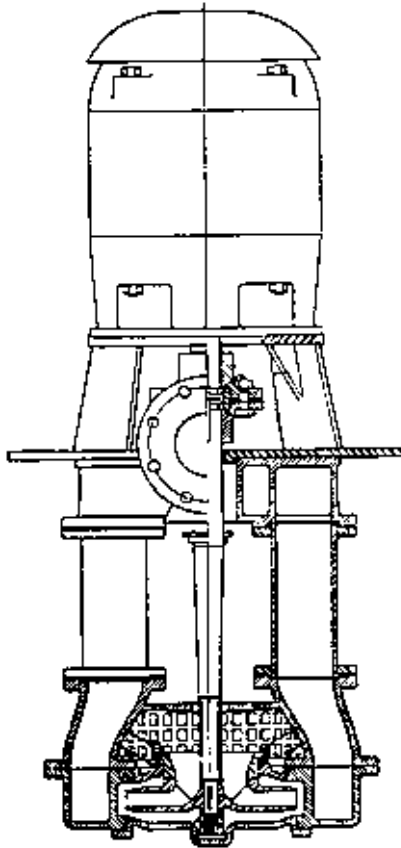


**FIGURE 6** Float-mounted pumps designed to skim the clean liquid in a settling pond (Hazleton Pumps, Inc.)



**FIGURE 7** Unique design float-mounted pump (Hazleton Pumps, Inc.)

lateral rotation of the float and the uprighting forces due to the additional buoyancy on one side (or end). The center of gravity must be within the center of buoyancy. If the center of gravity moves beyond the center of buoyancy, the float will overturn. It must also be remembered that, after a pontoon is submerged, that is the limit of buoyancy. In addition to these factors, wind effects must be considered. If the climate is not too severe,



**FIGURE 8** Cantilevered shaft design utilizing motor bearings (Hazleton Pumps, Inc.)

pumps on simple floats can be protected from ice damage if the float is surrounded with a simple air bubble system.

As the pump flow rates increase, fixed installations become more manageable. Figure 9 shows four 24 in (610 mm) discharge, 1250 horsepower (750 kW) vertical pumps. The pumps are of stainless steel in a mining operation. This is an ideal installation as a structure is in place for pump maintenance.

The selection of the discharge line will have a significant effect on the total pumping output. If selected for normal pumping conditions, the pipeline may not add significant capacity to the system by the use of an additional pump. As an example, examine an installation utilizing a 14 in (355 mm) Schedule 40 steel pipe discharge line for a normal flow of about 5000 gpm (1135 m<sup>3</sup>/h). Assume a friction head of 70 ft (21.3 m) and a static head of 180 ft (54.9 m), for a total pumping head of 250 ft (76.2 m). Figure 10 shows that adding a second pump to the system will not double the pumping capacity as the two pump characteristics are added to the system head curve. In this exaggerated example, adding a second pump will increase the total flow by less than 1000 gpm (227 m<sup>3</sup>/h). Note that each pump now will discharge less than 3000 gpm (680 m<sup>3</sup>/h). The obvious answer is to either use a larger discharge line and a different pump selection, or the use of a separate discharge line for each pump. In that case, the total capacity would be 10,000 gpm



**FIGURE 9** 24 in (610 mm) discharge, 1250 HP (750 kW) vertical pumps (Hazleton Pumps, Inc.)

(2270 m<sup>3</sup>/h). This becomes a study in economics for each installation. In the above example, this installation is obviously poorly designed. As pipeline velocities increase, discharge line transients may present problems on shutdown. The author is aware of one long pipeline that failed in 17 places on the first shutdown. Other factors must also be considered, such as the projected life of the project and the cost if the project is flooded.

Much has been said about pumping from mines. Obviously, the least costly method is to keep the water from entering the mining operation. It is not always applicable, but a ring of “deep-well” turbine pumps, on the periphery of the operation, can lower the water table sufficiently to keep the mining pit relatively dry. A typical large turbine pump with submersible motor is shown in Figure 11.

Pumps for operation in deep mines have different considerations. If a mine is not more than approximately 1200 ft (365 m) deep, Schedule 40 pipe is generally satisfactory for the pressure involved. For example, 12 in (305 mm) seamless Schedule 40 steel pipe is listed as 1200 lb/in<sup>2</sup> (82.75 bar) hydrotest pressure. However, if the water is corrosive, wall thickness allowance must be made, or stainless steel pipe used. 1200 lb/in<sup>2</sup> converts to approximately 2700 ft of water. Allowance must also be made for water hammer if the line velocity is high. Generally, average line velocities of 10 ft/s (3.1 m/s) will produce high tran-

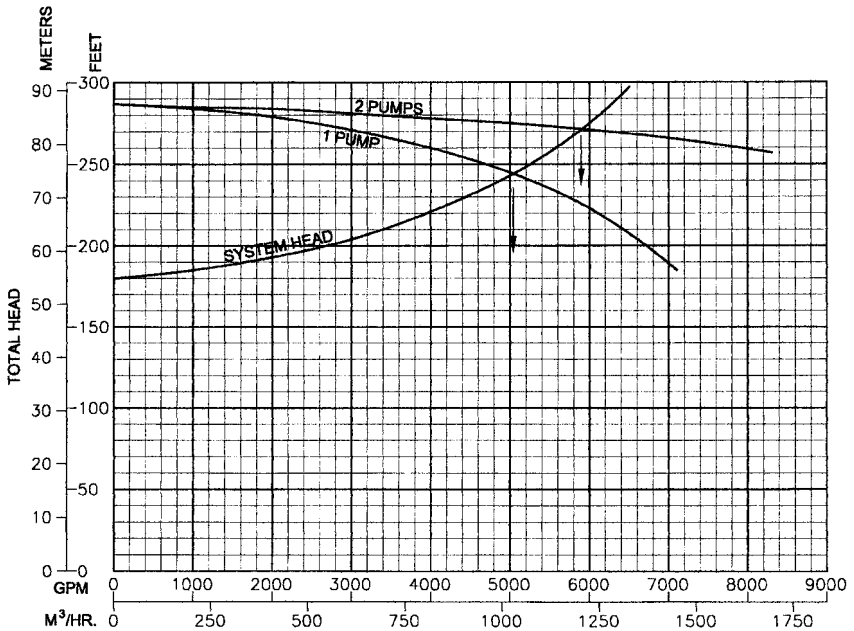


FIGURE 10 One and two pump operation on a system curve

sient pressures upon pump shutdown, so more conservative velocities should be selected. As these installations are generally long term, considerable savings can be obtained by reduced power requirements if the pipeline velocities are near 5 ft/s (1.5 m/s).

In designing a mine pumping system, an analysis must be made where the water is coming from. It is generally not practical to put the main pump station at the bottom of the mine if the bulk of the water is occurring at an upper level. If this is the case, a decision must be made for the pumping condition of the mine bottom pumps. Should they simply pump to the upper level or directly to the surface? Both financial and safety considerations are essential. Failure of upper level pumps may jeopardize the mine safety. These are decisions that involve much more than basic equipment selection. One solution to the problem of a possible power failure is the use of submersible pumps at the shaft bottom. Single-stage submersible pumps, as shown in Figure 12, are available to 600 HP (448 kW) and can readily pump to upper levels in case of flooding at the bottom level.

If the mine is deeper than 1200 ft (365 m), other approaches must be considered. Consideration of Class 250 or 300 valves and pipefittings may show that the cost warrants pumping only to an upper level to stay within the limits of the Class 150 fittings. This does not necessarily mean a duplicate pumping station as series pumps can safely be installed at an upper level. This is practical only if the bulk of the water occurs at or near the bottom level. Because there are mines deeper than 2000 ft (365 m), the problems become more acute. In any event, the main consideration is to conduct a study to determine at what level the greatest flow of water occurs.

A very old but interesting photo (see Figure 13) shows a sealed pump-room housing three 1000 HP (746 kW) bronze constructed pumps in a coal mine. This pump room had access only from an upper level so water could rise in the mine by approximately 200 ft (36.5 m) before flooding the pump room.

Not all mines suffer from ingress of a great deal of water, but many of those that do have closed because the cost of pumping was too great. An example is shown in Figure 14. There were three 2000 HP (1490 kW) pumps in one pump room in a zinc mine. Note in this



**FIGURE 11** A typical large turbine pump with submersible motor (Hazleton Pumps, Inc.)

photograph that these large pumps are in segments so they can be lowered into the mine and reassembled.

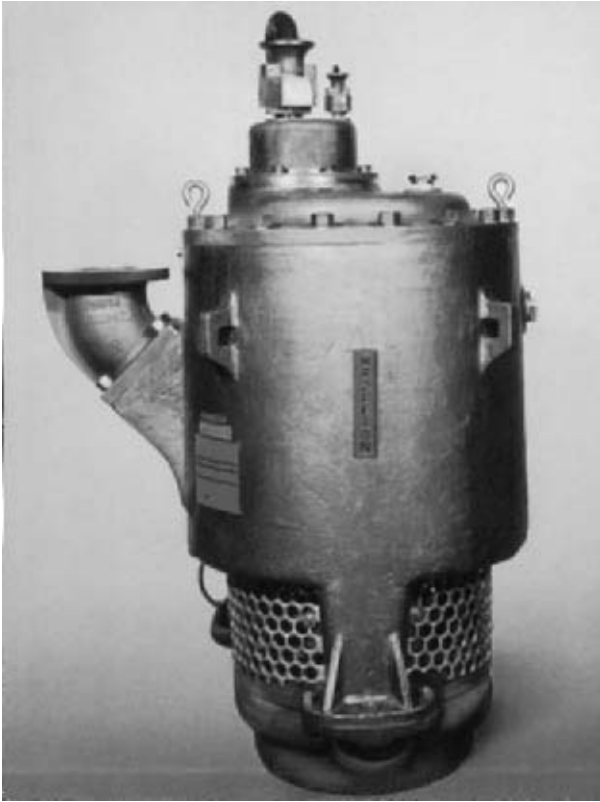
Pump discharge line forces must be calculated for all installations. The reactive forces from the piping must be isolated from the pump. Underground pumps generally operate at high pressure and the forces generated are high. Failure to adequately support and restrain the piping can cause pipe failure and result in severe pump misalignment.

### ***MATERIALS OF CONSTRUCTION***

---

Most water pumps perform quite satisfactorily with bronze impellers, wearing rings, and shaft sleeves, but the dirty or corrosive waters in mine service require superior materials. Because mine waters range from neutral (pH of approximately 7) to severely acidic (as low as pH 1.5 in some coal mines) and to very basic (as occurs in limestone mines and so on), there is no universally best material. The choice obviously is the lowest-priced material that gives satisfactory service life.

Many times, the decision must be made not on the basis of the best available materials, but on the basis of which material will best withstand the abrasive conditions during the intended life of the project. If there is a five-year anticipated life of the mine, there is little advantage in selecting materials that will last twice as long. Conversely, a mine with



**FIGURE 12** Single stage submersible pump (Hazleton Pumps, Inc.)

a projected life of 25 years would require the best commercially available materials. There are also the exotic alloys, but their use is seldom justified.

Assuming that there will always be a slight amount of solids present, the metallurgy given in Table 2 should be considered.

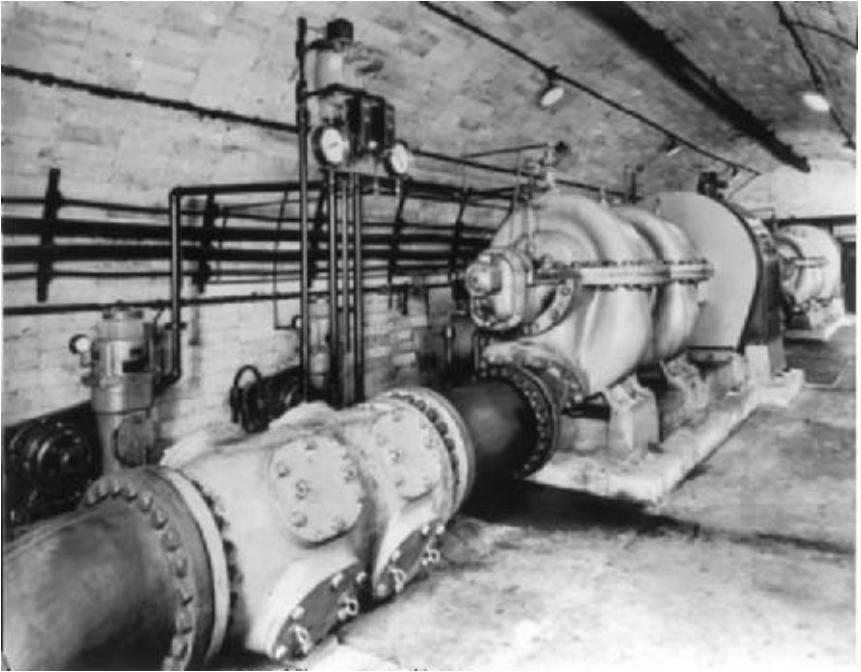
Care should be exercised when selecting alloys because many stainless steels do not have as great a strength as carbon steel. The same applies to bolting. Thus, a pump rated for high-pressure service with a carbon steel or alloy steel casing and bolting may not be suitable when made of bronze or stainless steel.

Although ceramic-coated shaft sleeves are excellent in many applications, remember that ceramic coatings are porous and that the base metal must be able to withstand the environment. Also, some ceramics will not be suitable in strongly basic water. Others, however, are suitable, and so a general specification for ceramic coating should never be made. A plasma-applied ceramic is generally denser and more serviceable than one applied by a simple flame spray.

## **HYDRAULIC CONDITIONS**

---

**Low-Head Pumps** For low-head pumps, up to approximately 150 ft (46 m), the installation must be carefully checked to prevent cavitation during periods of low-head operation. This is particularly important during one-pump operation on a parallel system. For



**FIGURE 13** A sealed room in a coal mine housing three 1000 HP (746 kW) bronze constructed pumps (Hazleton Pumps, Inc.)

example, if two 5000-gpm (1136-m<sup>3</sup>/h) pumps are discharging into a common discharge line against a static head of 80 ft (24 m) and a frictional head of 60 ft (18 m), the frictional head will be only 15 ft (4.6 m) when one pump operates alone at 5000 gpm (1136 m<sup>3</sup>/h). The total head will now be only 95 ft (69 m), and the single pump will carry out to a much higher capacity. Unless sufficient *NPSH* is available for the single-pump runout point, the pump will cavitate. Although the two pumps should be selected for 5000 gpm (1136 m<sup>3</sup>/h) at 140 ft (43 m) total head, the required *NPSH* should be determined not at 5000 gpm (1186 m<sup>3</sup>/h) but at the capacity corresponding to the intersection of the pump and system curves.

**High-Head Pumps** For high-head pumps, 1000 ft (305 m) head or more, the risk of cavitation for single-pump operation on a parallel system is less than for low-head pumps. For example, if the static head is 1000 ft (305 m) and the frictional head is 60 ft (18 m) when two 5000-gpm (1136-m<sup>3</sup>/h) pumps are operating, the total head will decrease from 1060 ft (323 m) to only 1015 ft (309 m) when one pump operates at 5000 gpm (1136 m<sup>3</sup>/h). This means that, for either one- or two-pump operation, the capacity of each pump will be approximately the same and the risk of runout cavitation is minimal.

**Waterhammer and Pressure Pulsations** A waterhammer analysis should be made of both high- and low-pressure pumping systems. Although the transient pressure pulsations are related to the rate of change of velocity rather than the magnitude of the steady-state condition, mine experience indicates that waterhammer problems can be anticipated when pipe velocities exceed 10 ft/s (3 m/s). In high-pressure pumping systems, it is not unusual for transient pressure pulsations to be as high as 300 lb/in<sup>2</sup> (2068 kPa) above or below the steady-state pressure.





**FIGURE 14** Three 2000 HP (1490 kW) pumps in one room in a zinc mine (Hazleton Pumps, Inc.)

Transient pressure pulsations have been experienced in low-pressure pumping systems. The danger here is that the low-pressure portion of the cycle will fall below atmospheric pressure and the pipe will collapse.

Although any pumping system for mine service should be analyzed in detail for transient pressure pulsations, experience has shown that adequate air bottles have proved to be one of the most effective and least expensive means of surge suppression. Slow-closing valves and flywheels have been used, but they must be sized correctly. This is especially true with high-speed pumps because these units possess little rotational inertia and will decelerate very rapidly on shutdown, with accompanying high-pressure surge.

## **SUMPS**

---

Permanent sumps are seldom used in open-pit mines because the sump area generally moves as the mining operation progresses. This means that the pump station must be portable, and the installation of the pumps on a barge provides the most convenient arrangement. Either horizontal or vertical pumps may be used, but vertical pumps eliminate the need for priming equipment. If the vertical pumps are of the overhung-shaft design, the stuffing box may be eliminated. This is important if the water is dirty. Although small cyclones can be used to clarify the water for pumps that have stuffing boxes, care must be taken to prevent leaves and other trash from blocking the gland water line. In freezing climates, special provision must be made to prevent the suction line, pump, and even the barge itself from freezing in place.

Underground mine sumps present special problems because they function not only as sumps but also as clarifiers. A well-designed sump is a good clarifier, but all too frequently



**TABLE 2** Materials of construction for mine pumps

	Neutral waters		Acidic waters		Basic waters	
	Moderate heads	High heads	Moderate heads	High heads	Moderate heads	High heads
Casing	Cast iron	Ductile iron/ cast steel	316 S.S./ alloy 20	17-4 PH	Cast iron	Ductile iron/ cast steel
Impeller	28% Cr	28% Cr	PH55A/ 17-4PH CD-4MCu	PH55A/ 17-4PH CD4-MCu	28% Cr	28% Cr
Wear rings	28% Cr	28% Cr	Same as impeller	Same as impeller	28% Cr	28% Cr
Shaft sleeve	28% Cr or 303 S.S. ceramic- coated	28% Cr or 303 S.S. ceramic- coated	316 or alloy 20 ceramic- coated PH55A, etc.	316 or alloy 20 ceramic- coated PH55A, etc.	28% Cr or 303 S.S. ceramic- coated	28% Cr or 303 S.S. ceramic- coated
Shaft	Carbon steel  Alloy 20 CD4-MCu 28% Cr 304 S.S. 316 S.S. 17-4 PH PH55A	High- tensile alloy steel 21% Cr 26% Cr 28% Cr 19% Cr 19% Cr 17% Cr 20% Cr	316 S.S./ alloy 20 29% Ni 5% Ni — 10% Ni 10% Ni 4% Ni 10% Ni	17-4 PH 2.5% Mo 2.0% Mo — — 2.5% Mo — 3.5% Mo	Carbon steel	High- tensile alloy steel      Hardenable Hardenable

inadequate provisions are made for cleaning the sump. If it is not cleaned at regular intervals, the loss of storage capacity may be critical in the event of a power failure. Furthermore, a sump partially filled with solids does not give the proper retention time for clarification, and the solids are directed into the pump. Although few sumps can economically be made large enough for complete clarification, it is important that a large portion of the solids be removed. This is particularly true for 3600-rpm pumps because the high-speed generally produces a high head per stage and the high differential pressure between stages causes severe wear if abrasive solids are present. Some mines use conventional thickeners and flocculating agents in an attempt to keep a high concentration of solids from reaching the pump.

Some general rules should be considered in designing sumps for underground pump rooms:

1. Attempt to get a complete analysis of the water (from another portion of the mine or from an adjacent mine if necessary).
2. Analyze the sample for corrosive properties to determine the proper materials of construction for the pump.
3. Analyze the sample for possible scale buildup in the pipeline and pumps. Check the velocity effect, if any, on the buildup rate.
4. Determine the percentage of suspended solids in the sample, its screen analysis, and the settling rate for various fractions. Determine the sump dimensions necessary for removal of all solids and then for progressively larger solids in order to select the most economical size.

5. Compare the sump size as determined in rule 4 with the size required for physical storage capacity for (a) continuous pumping, (b) off-peak power pumping, (c) programmed pumping, and (d) storage during estimated maximum length of power interruption.
6. Calculate practical sump dimensions, considering the geologic conditions.
7. Install grit traps ahead of the sump to remove large, heavy solids. Consider methods for cleaning the grit traps.
8. Install trash screens to prevent wooden wedges, and so on from entering the sump.
9. Review sump cleaning methods and program. The best-designed sump is of no value if it is not cleaned. Compare mechanical cleaning methods with cost of parallel sumps.
10. Review the suction requirements of the pumps to be used. Because of altitude, temperature, distance from low water level to pump centerline, and suction line loss, the available *NPSH* may be inadequate for even an 1800-rpm pump. If a decision as to pump size, type, and speed has been made and an *NPSH* problem does exist, a decision must be made either to use low-speed booster pumps or to lower the pump room level to below the sump level. From a safety standpoint, the use of a booster pump is preferable, although it does add another piece of equipment.
11. Where the storage capacity is inadequate to meet possible power failures, consider either vertical pumps—possibly up to 100 ft (30 m)—for the shaft bottom pumping up to the main pump station level, or sealed pump rooms that can operate over wide variations in the sump level from a 15-ft (4.6-m) suction lift to a positive head of several hundred feet.
12. Determine the final design based on a compromise between the mine engineer (who wants maximum output), the electrical engineer (who wants small starting load), the geologist (who wants small sump dimensions), and the mechanical engineer (who wants the most reliable and easily maintained equipment).

### **AUTOMATIC PUMP CONTROL**

---

With proper instrumentation, almost all pump stations can be operated automatically. Remote monitoring is simple, relatively inexpensive, and can provide safe operation and signaling of nearly all operating conditions. Equipment is presently available to measure, record, and transmit the operating conditions to remote locations. The proper equipment can thus relieve worry about the operation of the facility even if it is many miles from the operation's headquarters. Automatic control can be a simple float switch or a pressure switch, or it can be sufficiently complex to provide reliable operation under the most critical or adverse conditions. Automatic control can provide greater reliability, and its cost can depreciate over only a few years. Furthermore, the automatic recording of flow rate, flow totalizing, and periods of operation provides valuable data for analyzing the performance of the pumping installation as well as the possible cost savings in pumping during off-peak power periods.

Where the safety of a mine is dependent on the reliable operation of the dewatering pumps and controls, the following minimum requirements should be considered:

1. There should be a sump level alarm for high water, both local and remote (at the surface).
2. Sump level control should be dependable. For example, electrodes are generally unreliable in waters that leave a conducting film.
3. The control should be programmed where more than one pump is installed. However, the use of an alternator is not always desirable because all pumps are exposed to the same degree of wear. It is preferable to have one standby pump programmed through a sequence selection switch to operate at least once per week.

4. Pump priming should be positive. Hydraulic devices should be combined with electric controls so complete dependence is not on the electric control. The presence of water in the pump should be detected to prevent the starting of a dry pump.
5. A delay circuit should be provided to ensure complete priming.
6. The control should provide for at least three starting attempts (unless an overload has occurred).
7. The priming time should be limited (if under a suction lift system).
8. The control should provide for a restart in the event of a false loss of prime on start-up (suction lift system).
9. Pump and motor bearings should have thermostats to stop pumps in the event of bearing failure.
10. Vibration monitoring may be important. This is particularly true for vertical pumps.
11. Pressure controls should indicate normal pressure and fail-safe in the event of a loss of pressure (broken column line, and so on).
12. Flow indication (check valve flow switch) is needed to signal a shaft failure.
13. Remote indication (generally at the mine office) should provide at least an indication of operation and signal pump failure or high water. More detailed information may be transmitted.
14. For long distances, investigate the use of carrier-current indication schemes, together with signal multiplexing, and so on.
15. Provide a method to test the control and alarm system.

## **DRIVERS**

---

Open-pit mines use electrically driven mining equipment, such as drag lines and shovels, and the availability of power has permitted the use of electrically driven pumps. There are still many gasoline-driven or diesel-driven units, but the convenience of electric power, particularly for automatically controlled units, has increased the trend to electric drive. The availability of reliable high-voltage cable has made portable high-voltage equipment safe and economical. Pumps in open-pit service are seldom provided with sophisticated control or drive mechanisms. The primary requirements are reliability, portability, and wear resistance.

In locations where rainfall may be heavy and there is danger of power failure, a combination of electric drive and engine drive is used. The engine can be direct-coupled to the pump through a motor with a double-extended shaft or with a clutch between the engine and the motor. Automatic control is simple and reliable.

Although some steam-driven pumps still exist in underground service, their number is rapidly decreasing. Electric motor drive is the simplest for automatic control. Variable-speed units, however, are seldom used in underground service because the ratio of static head to total dynamic head is quite high. Thus the frictional loss is not a large percentage of the total head loss and not much advantage is gained by variable speed. The solution is usually a multiple-pump installation. This must be designed with care because it is possible to raise the frictional head to a point where an additional pump produces little additional capacity. Multiple discharge lines are the answer and are frequently used for safety reasons. In normal service, all discharge lines are used in parallel, although conservative design allows each line to handle the required capacity.

As with all pumping installations, a complete set of system-head curves must be prepared to analyze the power requirements under all conditions.

Motor enclosures are important in underground service. Because of the high humidity, special insulation (epoxy encapsulated, and so on) should be specified. Dripproof enclosures are the minimum requirement, with weather-protected Type I the preferred construction. Heaters should also be provided. Screens should be installed to prevent the

entrance of rats. Winding temperature detectors, bearing thermostats, and ground-fault detectors are recommended in mine service and should be incorporated in the pump-control and alarm circuits.

Although the starting torque of a centrifugal pump is low, the available torque may have to be checked in some cases. A normal-torque motor should be suitable for pumps in the range of 500 to 3000 (10 to 60) specific speed. High-specific-speed pumps, however, have the highest power at shutoff, and it will be necessary to examine the starting arrangements for such pumps.

Starting a pump against a long empty pipeline may present overload problems, and repeated starts may be necessary. In such cases, the number of permissible starts per hour should be checked. Winding temperature detectors are important in such applications.

Although reduced-voltage starters may be required in some instances, most modern mines have electrical facilities designed for across-the-line starting. This is preferable because the starting equipment is cheaper. Before deciding on a reduced-voltage starter, the effect of the starting load on the transformer and line impedance should be checked. It may be that the voltage drop will eliminate the requirement for reduced-voltage starters. On the other hand, the effect on the primary side should be checked so the voltage drop is not so large as to drop out other equipment.

Synchronous-motor drives are seldom used unless they are large (generally at least 1000 hp) (750 kW) and then only if they are in relatively continuous service. Under such conditions, they can be operated under "leading current" conditions for power factor correction. Smaller installations frequently provide capacitors at the pump installation to provide the necessary correction for a particular installation.

Surge protection from lightning should not be overlooked. Some locations are particularly susceptible to lightning damage, especially to long surface lines. Lightning arresters should be provided at the surface, and surge arresters should be mounted at the motor location.

## REFERENCES

---

1. American National Standard for Centrifugal Pumps for Design and Application, ANSI/HI 1.3-2000, Hydraulic Institute, Parsippany, NJ [www.pumps.org](http://www.pumps.org).

---

# SECTION 9.11

---

# MARINE PUMPS

---

WILLIAM J. SEMBLER

Pumps used in marine shipboard applications, both commercial marine and Navy, can typically be divided into several groups. These groups include pumps associated with a vessel's propulsion, pumps used with the generators that produce electricity, pumps used in ship's service systems, pumps used to provide hotel services for crew and passengers, and pumps that are used in cargo or other specialized systems.

Because marine pumps must operate on a moving platform, they should be designed to withstand dynamic loads resulting from vessel motion (for example, pitch, roll, and so on). In addition, they must often operate in a hot, humid, and potentially corrosive environment. In addition, marine pumps must frequently be suitable to operate with a range of flow rates to accommodate anything from operation of the vessel at full speed to operation in port with the propulsion equipment secured. Furthermore, the minimization of size (especially the required deck space) and weight is always important when designing marine equipment. For this reason, many shipboard pumps are mounted vertically (Figures 1 and 2), and smaller units are frequently furnished in a close-coupled configuration (Figure 3) with the pump's rotating parts mounted directly on the driver's shaft. To enable them to stand freely under pitch and roll conditions, vertically mounted shipboard pumps often have larger bases than comparable shore-side units. Typical materials used in the construction of marine centrifugal pumps are listed in Table 1.

A description of the features typically incorporated into the designs of pumps used in selected shipboard applications follows. This information is general in nature, however, and may not apply in all cases based on the requirements for specific installations or the preferences of vessel owners and designers.

- 1 Casing
- 2 Impeller
- 3 Casing wearing ring
- 4 Impeller wearing ring
- 5 Shaft
- 6 Shaft sleeve
- 7 Packing
- 8 Gland
- 9 Thrust bearing
- 10 Line bearing
- 11 Bearing housing
- 12 Pump base
- 13 Motor bracket
- 14 Coupling

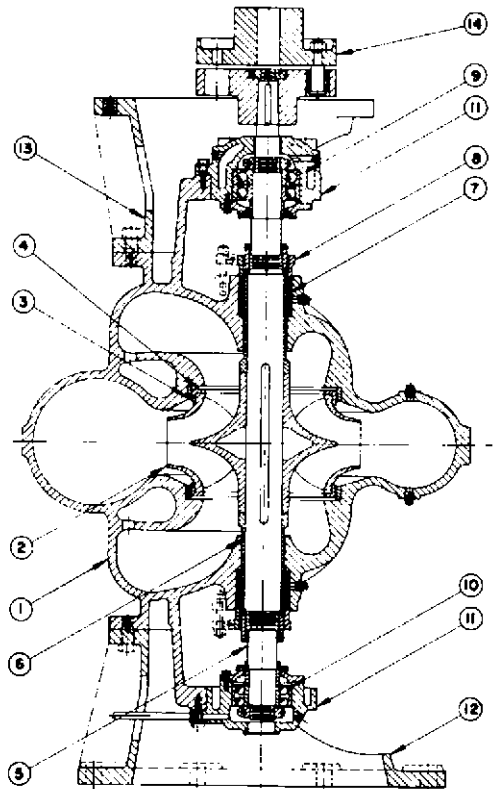


FIGURE 1 Vertical between-bearings centrifugal pump (Flowserve Corporation)

## PROPULSION APPLICATIONS

### Steam-Turbine-Propelled Vessels

**FEED PUMPS** A main feed pump is used to return water to a steam-powered vessel's boilers or steam generators. On a typical steam ship with fossil-fueled boilers, a main feed pump takes suction from a deaerating feed tank (DFT) and discharges feedwater to the steam drum in each of the vessel's boilers. In many cases, a main feed pump's discharge is connected to two separate lines that both lead to the boilers: a main feed line and an auxiliary feed line. In addition, the feedwater usually passes through one or more heaters before entering the steam drums. Although a single feed pump is frequently sized to handle a vessel's full-load requirements, some ships have multiple partial-capacity feed pumps that operate in parallel. Additional pumps are ordinarily provided for standby duty.

Typical feed pump configurations include single- and two-stage centrifugal pumps that are close-coupled to steam turbines (Figure 4) and multistage flexibly coupled pumps that are driven by steam turbines or electric motors. Although flexibly coupled feed pumps often have cast axially split volute-type casings (Figure 5), barrel pumps with diffusers and forged cylindrical casings are sometimes used. Turbine-driven feed pumps are usually mounted horizontally. Motor-driven feed pumps, however, have been used in both horizontal and vertical configurations.

- 7450 Coupling guard
- 3261 Bearing cover, driver side
- 3712 Bearing lock nut
- 4595 Lock washer
- 3132 Adapter
- 4542 Bearing-cover gasket
- 3262 Bearing cover, pump side
- 4300/2 Lip seal
- 6573 Gland stud
- 4120 Gland
- 4610/2 Inner O-ring
- 4113 Cooling cap
- 1222 Stuffing-box cover
- 4521 Casing gasket
- 6710 Impeller key
- 1111 Casing
- 4510 Impeller-lock-washer gasket
- 4552 Impeller-nut gasket
- 3170 Pump base
- 2912 Impeller nut
- 6543 Impeller lock washer
- 1500 Casing wearing ring
- 2200 Impeller
- 1521 Stuffing-box-cover wearing ring
- 2450 Shaft sleeve
- 4133 Throat bushing
- 4134 Lantern ring
- 4610/1 Outer O-ring
- 4130 Packing
- 6731 Shaft-sleeve key
- 2540 Slinger
- 3042 Line bearing
- 3853 Grease nipple
- 2100 Pump shaft
- 3133 Bearing housing
- 3041 Thrust bearing
- 3853 Grease nipple
- 6742/2 Pump coupling key
- 7112 Coupling
- 3160 Mounting frame
- 6742/1 Motor coupling key
- 8010 Motor

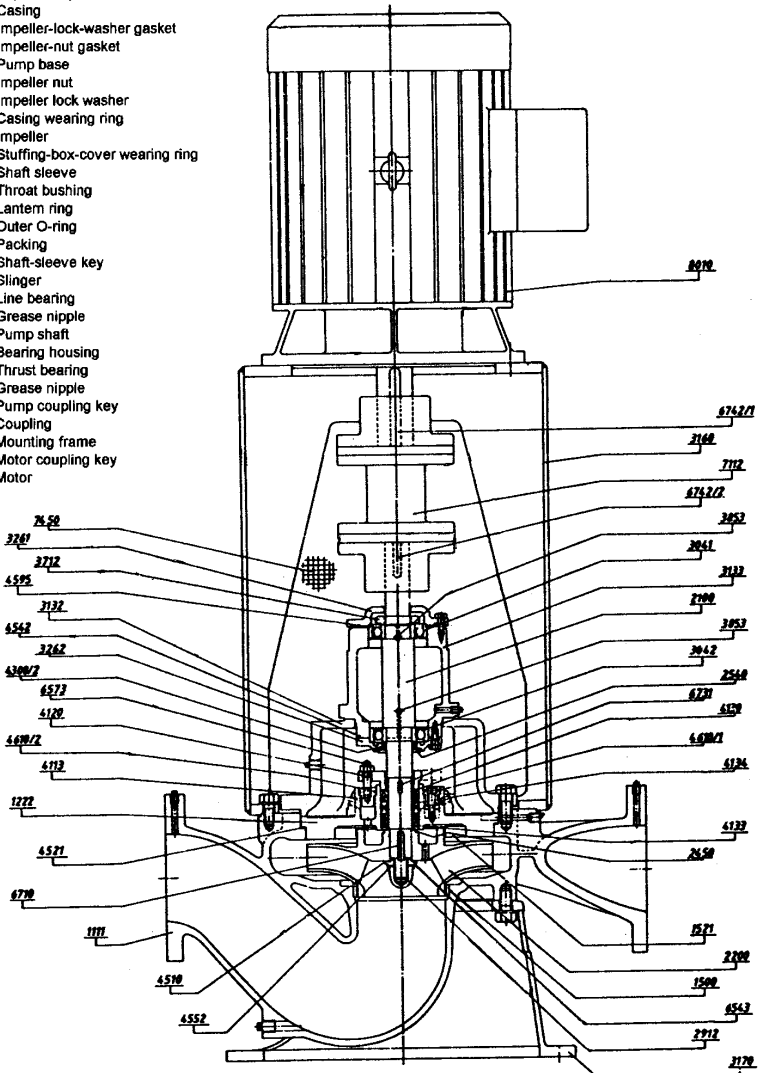


FIGURE 2 Vertical back-pull-out centrifugal pump (Flowservice Corporation)

- |   |                         |    |                        |
|---|-------------------------|----|------------------------|
| 1 | Casing and suction head | 7  | Seal cage              |
| 2 | Impeller                | 8  | Shaft                  |
| 3 | Casing wearing ring     | 9  | Slinger                |
| 4 | Impeller nut            | 10 | Shaft-sleeve seal ring |
| 5 | Shaft sleeve            | 11 | Packing                |
| 6 | Gland                   |    |                        |

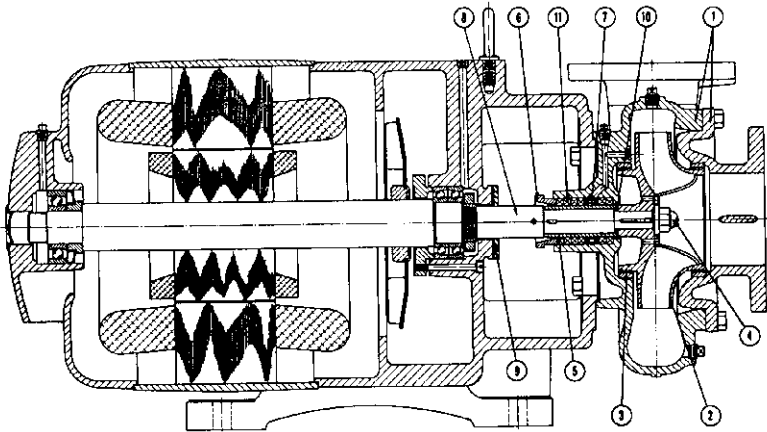


FIGURE 3 Horizontal close-coupled centrifugal pump (Flowserve Corporation)

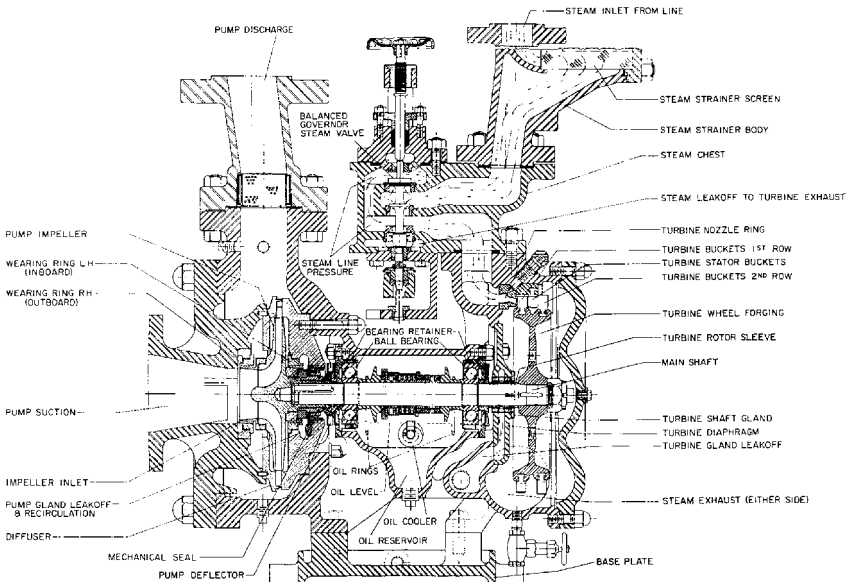


FIGURE 4 Close-coupled single-stage centrifugal main feed pump (Coffin Turbopump)



- |   |                     |   |                |
|---|---------------------|---|----------------|
| 1 | Casing              | 5 | Shaft          |
| 2 | Impeller            | 6 | Shaft Sleeve   |
| 3 | Stage piece         | 7 | Thrust bearing |
| 4 | Casing wearing ring | 8 | Line bearing   |

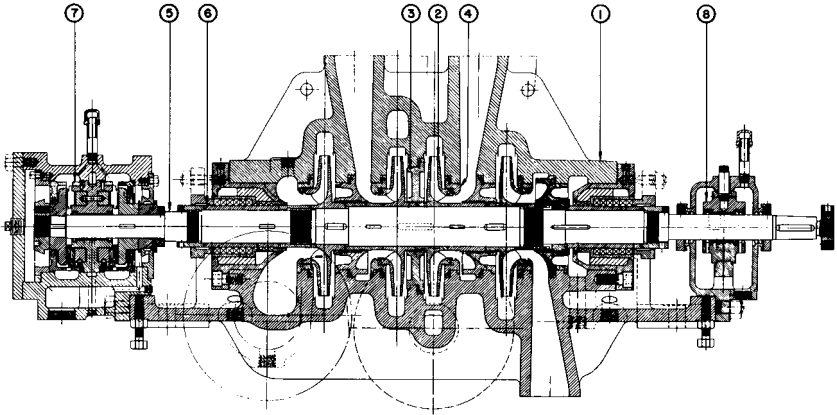


FIGURE 5 Flex-coupled multistage centrifugal main feed pump (Flowsolve Corporation)

Motor-driven feed pumps may have grease-lubricated external bearings. Bearings in a turbine-driven feed pump, however, are usually lubricated with oil that is circulated by a shaft-driven rotary pump. Oil discharged by this pump also ordinarily lubricates the turbine's bearings and may be used in the pump's governor. A strainer, filter, and seawater-cooled heat exchanger are often installed in the lubricating-oil system. The lubricating oil used with the turbine-driven feed pumps on many steam-turbine-propelled vessels is the same grade of oil used in the main propulsion lubricating-oil system.

Although packed stuffing boxes are used to seal shaft penetrations in many marine feed pump casings, to reduce stuffing-box leakage, some feed pumps are fitted with mechanical seals. In addition, a condensate-injection shaft seal consisting either of a non-rotating labyrinth-type fixed breakdown bushing or a series of spring-loaded floating rings that are stacked axially is sometimes used. When a feed pump that has a condensate-injection shaft seal is operating, cool condensate is injected into the seal and fills the close radial clearance between the nonrotating seal parts and a rotating shaft sleeve. A small portion of this condensate may flow into the pump. The remainder, however, flows outward and enters a collection chamber that is usually piped back to the vessel's gland-exhaust condenser.

During constant-speed operation, the capacity of water delivered to a boiler by a main feed pump is typically controlled by the throttling action of an automatic feedwater-regulating valve. However, when steam is used to drive a feed pump, the amount that the regulating valve must be throttled is often reduced by controlling the amount of steam supplied to the pump's driver and, therefore, the pump's operating speed with either a constant-pressure or a constant-differential-pressure governor.

A constant-pressure governor automatically regulates a feed pump's operating speed to maintain a constant pressure at the pump discharge. If there is a reduction in the boiler load and the feedwater-regulating valve begins to close, the feed pump's discharge pressure will rise and the capacity of feedwater that the pump delivers to the boiler will be reduced. The constant-pressure governor, however, will sense the rise in discharge pressure and will reduce the pump's speed until this pressure returns to the desired value. As a result of the speed reduction, the amount that the regulating valve must close to limit the feedwater flow rate is reduced. An increase in boiler load has the opposite effect.

A constant-differential-pressure governor (sometimes referred to as an excess-pressure governor) regulates a steam-driven feed pump's operating speed to maintain a set difference between the pump discharge pressure and the pressure on the boiler-side of the feedwater-regulating valve. Because changes in the feed flow entering the boiler result, primarily, from variations in pump speed, the throttling action of the feedwater regulating valve is greatly reduced.

A relief valve is often installed on the discharge side of a main feed pump to protect the feed system from overpressurization. In addition, to prevent a feed pump from operating with too low a capacity, which could occur when the boiler load is low, a recirculation line is typically connected from the pump discharge to the DFT. An orifice is typically installed in the recirculation line to limit flow and to reduce the pressure of the water being recirculated to match the pressure in the DFT. A valve that can be closed during high-load operation is also frequently mounted in a feed-pump recirculation line.

Steam turbines that are used to drive feed pumps are generally protected with low-lubricating-oil-pressure, overspeed, and high-turbine-exhaust-pressure trips. In addition, a low-suction-pressure trip is sometimes provided to prevent a feed pump from operating with too low a suction pressure, which can result in cavitation, overheating, and a loss of load on the pump's driver.

In addition to the main feed pumps, a smaller capacity feed pump is also installed on some steam-powered vessels for use in port or during emergencies. Steam-driven direct-acting piston-type (Figure 6) and motor-driven plunger-type reciprocating pumps, either vertically or horizontally mounted, are often used for in-port feed service.

Because the feedwater removed from a DFT is normally at its vapor pressure, the net positive suction head (*NPSH*) available to a main feed pump is essentially equal to the elevation of the water level within the DFT above the feed pump, less losses in the feed-pump suction line. On a vessel where the elevation of the DFT is not sufficient to provide an adequate *NPSH* to the main feed pumps, separate electric-motor-driven centrifugal-type booster pumps are typically installed between the DFT and the main feed pumps. The booster pumps, which operate in series with but at a much lower speed than the main feed pumps, raise the pressure of the feed water entering the main pumps and, therefore, reduce the potential for cavitation.

**MAIN CONDENSATE PUMPS** A typical main condensate pump takes suction from the hotwell in a main condenser and discharges condensate, through various heat exchangers, to a deaerating feed tank (DFT). Vertically mounted centrifugal pumps with two or more stages are frequently used in this application. Although many of these pumps are driven by electric motors, some main condensate pumps are driven through reduction gears by steam turbines. Two condensate pumps are generally provided for each main condenser, with each pump sized to handle full-load requirements.

A typical two-stage condensate pump (Figure 7) is fitted with grease-lubricated ball bearings at the upper end of its shaft to absorb both axial and radial loads. In addition, an internal water-lubricated radial sleeve bearing is often installed between the two impellers. The first-stage impeller is usually mounted near the lower end of the shaft, which increases its submergence. In addition, its suction eye is directed upward, which enables the impeller to be self-venting. To help facilitate the removal of any air that may enter the pump, a vent line is ordinarily connected from the suction side of a condensate pump's casing to the upper portion of the condenser. The second-stage impeller is ordinarily mounted near the upper end of the condensate-pump shaft with its suction eye directed downward. With this orientation, the hydraulic axial thrust applied the second stage impeller opposes the axial thrust acting on the first-stage impeller, and the net axial load that must be absorbed by the pump's thrust bearing is reduced. In addition, condensate at the base of the shaft seal has already passed through both impellers and is, therefore, at an elevated pressure. This helps to prevent air from being drawn into the pump through the shaft seal. The effectiveness of the shaft seal, which can consist of a packed stuffing box or a mechanical seal, is also frequently increased by injecting pressurized condensate recirculated from the pump's discharge into the seal area.

The condensate removed from a condenser's hotwell is normally at or close to its vapor pressure. Consequently, the net positive suction head (*NPSH*) available to a condensate

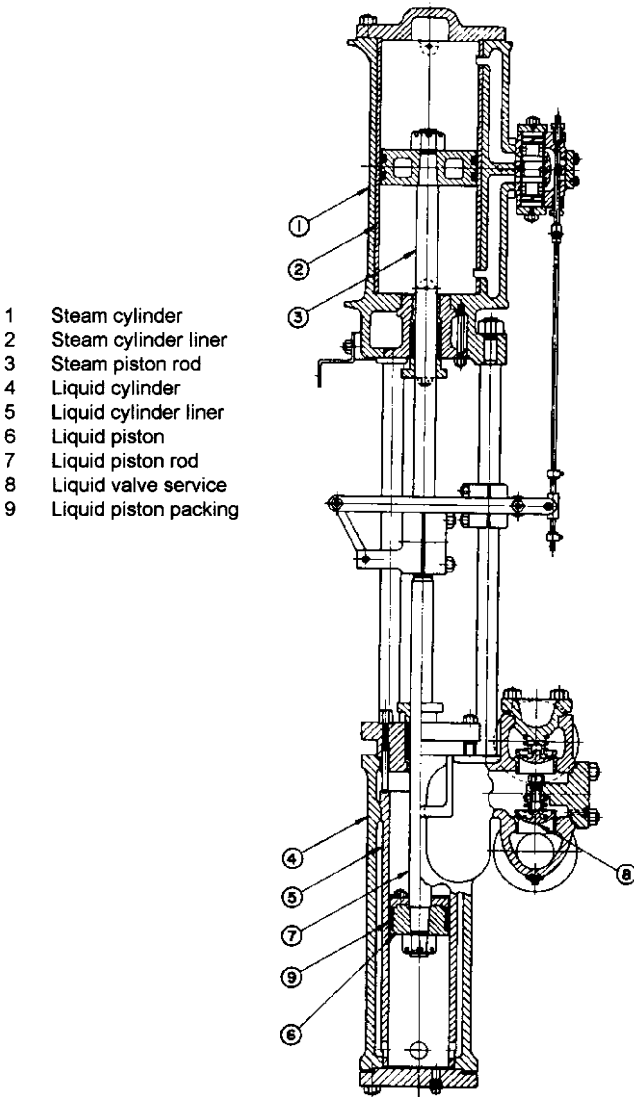


FIGURE 6 Simplex direct-acting reciprocating in-port feed pump (Flowserve Corporation)

pump is essentially equal to the height of the water level in the hotwell above the pump's first-stage impeller, which is seldom more than a few feet, less frictional losses in the suction piping. To help increase the *NPSH* available to main condensate pumps, they are ordinarily installed as low in a vessel as is practicable. They also frequently have special low-*NPSH* first-stage impellers.

If a condensate pump is driven by a steam turbine or by a variable-speed electric motor, its operating speed can be adjusted with plant load. This allows the capacity at which condensate is removed from the hotwell to match the rate at which steam is exhausted into

- 1 Casing
- 2 1st-stage impeller
- 3 2nd-stage impeller
- 4 Impeller wearing ring
- 5 Casing wearing ring
- 6 Internal bearing
- 7 Shaft
- 8 Shaft sleeve
- 9 Journal sleeve
- 10 Bearing housing
- 11 Motor bracket
- 12 Pump base

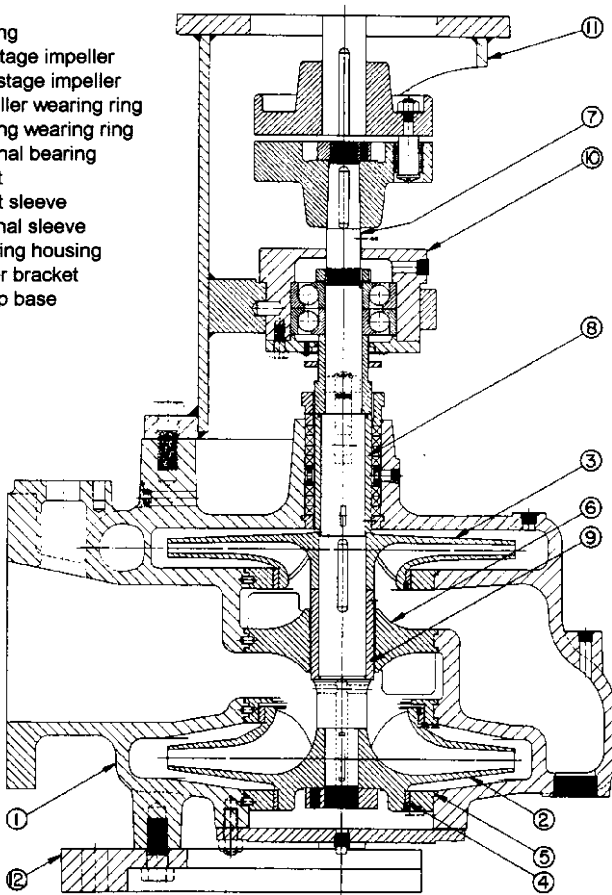


FIGURE 7 Two-stage centrifugal main condensate pump (Flowserve Corporation)

the condenser. This is usually accomplished by means of water level control. Alternatively, when a constant-speed driver is used, the capacity delivered by a main condensate pump is sometimes regulated by cavitation, which is referred to as submergence control. When submergence control is utilized, a reduction in plant load will typically result in a reduction in the main-condenser hotwell level and, therefore, in the *NPSH* available to the condensate pump. After the *NPSH* available drops below the condensate pump's *NPSH* requirement, the capacity being removed from the hotwell will be reduced by cavitation within the pump. As the hotwell level continues to drop, the amount of cavitation occurring will increase, and the pumped capacity will continue to be reduced until it eventually matches the rate at which steam is entering the condenser. When this occurs, the water level in the hotwell will stabilize at an elevation where the *NPSH* available to the condensate pump is equal to the pump's *NPSH* requirement at the new reduced capacity being pumped. Pumps designed to operate with submergence control need to be of robust construction and low energy level (per stage) to prevent damage from cavitation and cavitation-induced vibration.

To avoid operation with excessive cavitation, the capacity delivered by a constant-speed condensate pump can be regulated by throttling the pump's discharge valve as

needed to maintain a constant condenser-hotwell level. However, when steam-jet air ejectors are used to deaerate a condenser, condensate-pump operation at too low a capacity can result in insufficient cooling in the ejector inter- and after-condensers. In addition, low-capacity operation can lead to surging caused by suction and discharge recirculation within a condensate pump. To prevent these problems from occurring and to reduce the need to throttle a condensate pump's discharge valve, a recirculation line back to the condenser is frequently used. This line is connected to a tee in the condensate-pump discharge piping, downstream from any air-ejector and gland-exhaust condensers. With this arrangement, if the hotwell level drops, a valve in the recirculation line can be opened, either manually or automatically, to permit a portion of the water discharged by the condensate pump to be returned to the condenser. The hotwell level can be maintained, therefore, at a value that is sufficient to suppress cavitation. In addition, because the condensate pump can always operate at or near its rated capacity, low-flow operation is avoided. Furthermore, an adequate flow of condensate through air-ejector condensers, when used, and a vessel's gland-exhaust condenser can be maintained during plant start-up and low-load operation. In some cases, the condensate-recirculation line may also be fitted with a thermostatically-controlled valve that opens and permits the condensate flow rate through the air-ejector condensers to increase when the temperature of the condensate leaving these heat exchangers exceeds a pre-set value.

**CONDENSER-EXHAUSTING PUMPS** Electric-motor-driven liquid-ring vacuum pumps are sometimes used instead of steam-jet air ejectors to deaerate a main condenser. The vacuum created by a liquid-ring vacuum pump is limited by the vapor pressure of the liquid compressant (water) within the pump's casing, which increases with temperature. Therefore, water separated from the gases discharged by a liquid-ring condenser-exhausting pump is generally cooled in a heat exchanger before being returned to the pump. Two pumps that are each capable of maintaining the required vacuum during full-load plant operation are frequently provided for each main condenser.

**FRESHWATER-DRAIN-COLLECTING-TANK PUMPS** A freshwater-drain-collecting-tank (FWDCT) pump (also sometimes referred to as an atmospheric-drain-tank pump) typically transfers condensate (collected from uncontaminated drains that are above atmospheric pressure) from a freshwater-drain-collecting tank to a deaerating feed tank (DFT). Electric-motor-driven single-stage centrifugal pumps are often used in this application. Two full capacity pumps are usually provided. With this arrangement, the on-line pump is often started and stopped automatically by a float control in the drain tank. The condensate removed from a freshwater-drain-collecting tank, which is ordinarily at a temperature of approximately 200 to 210°F (93 to 99°C), is close to its boiling point. To increase the net positive suction head (*NPSH*) available to a vessel's FWDCT pumps, they are frequently installed as far below the drain tank as practicable.

**MAIN CIRCULATING PUMPS** On a steam-powered vessel, a main circulating pump delivers seawater to a main condenser that receives steam exhausted from a propulsion turbine. In addition, a portion of the seawater discharged by a main circulating pump may be diverted to other seawater-cooled heat exchangers, such as the main lubricating-oil coolers. After passing through the main condenser or another cooler, the seawater is directed overboard. In addition to the main suction flange, which is connected to a sea chest, some main circulating pumps also have an auxiliary side-suction connection that can be used for emergency dewatering of the machinery space bilge.

Typically, one or two main circulating pumps are provided for each of a vessel's main condensers. Single-stage axial-flow propeller pumps (Figure 8) that deliver high flow rates at relatively low discharge pressures are often used in this application. In many cases, the pump is not furnished with a thrust bearing. Instead, the pump shaft is rigidly coupled to the driver's shaft, and axial loads are absorbed by the driver's thrust bearing. Radial loads applied to the pump shaft, however, are generally absorbed by a journal bearing that is located above the overhung propeller. During operation in harbors and inland waterways, the water delivered by a main circulating pump will often contain silt, sand, and other abrasives. Consequently, internal journal bearings that are lubricated by water discharged

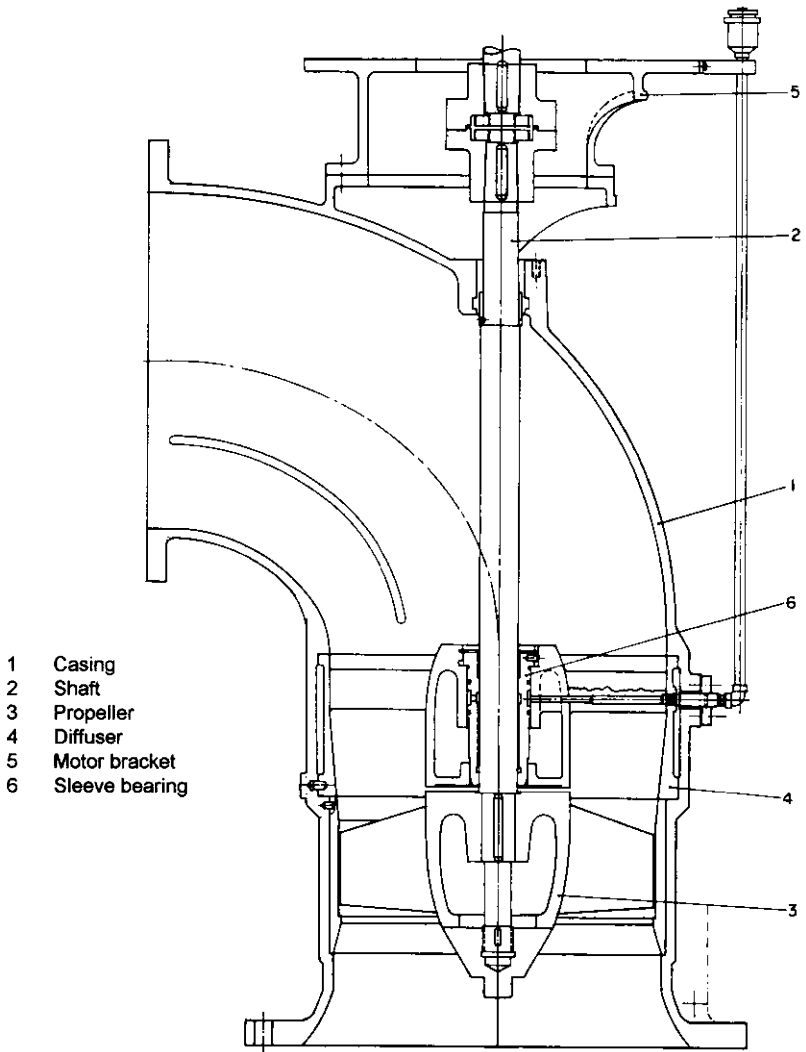


FIGURE 8 Axial-flow main circulating pump (Flowsolve Corporation)

from the propeller are sometimes furnished in abrasion-resistant grades of rubber or composite materials. Alternatively, some main-circulating pump internal bearings are lubricated by grease or clean water supplied through an external connection in the pump's casing.

When higher discharge pressures are required, single-stage mixed-flow pumps with overhung end-suction impellers or single-stage radial-flow pumps with double-suction impellers mounted between bearings are sometimes used as main circulating pumps.

Main circulating pumps are generally driven either by steam turbines with reduction gears or by two-speed electric motors. This permits the capacity of seawater discharged through the condenser to be reduced during system startup and shutdown and other peri-

ods of low-plant-load operation by reducing the speed of the circulating pump's driver. Many steam ships are fitted with a scoop-injection system that permits seawater to be forced through the main condensers by the forward momentum of the vessel. With this arrangement, the main circulating pumps are usually stopped whenever the vessel is operating above a certain speed.

**FUEL-OIL SERVICE PUMPS** A fuel-oil (FO) service pump typically takes suction through either high- or low-suction ports in the FO service or settling tanks and supplies fuel oil to the burners in a steam ship's oil-fired boilers. At least two service pumps each capable of delivering the vessel's full-power fuel-oil requirement are generally provided. FO service pump suction and discharge lines are generally fitted with duplex strainers. In addition, one or more flow meters and heaters are frequently installed in a FO service system.

Horizontally and vertically mounted multiple-screw rotary pumps that are driven by either steam turbines or two-speed electric motors are often used in this application. In addition, some older ships have steam-driven reciprocating FO service pumps. When a vessel normally burns heavy (residual) fuel oil, which must be heated before being delivered to a boiler's burners, a separate electric-motor-driven rotary pump is also usually provided to supply unheated distillate fuel oil to the boilers during plant start-up.

The steam flow to a turbine-driven rotary or a direct-acting reciprocating FO service pump is often regulated with a constant-pressure governor that acts to maintain a constant FO-service-pump discharge pressure. With this arrangement, changes in the flow rate passing through the FO service pump result from variations in the pump's operating speed. When a two-speed electric motor is used to drive a FO service pump, the motor is ordinarily operated at low speed during low-plant-load periods (for example, in port) and at high speed during high-plant-load periods. However, during operation at either speed, a motor-driven FO service pump typically discharges more oil than the amount required by the burners. The excess oil is usually returned to the suction side of the FO service system through a recirculation line. The flow rate through this recirculation line is often regulated by an automatic valve that maintains a constant FO-service-pump discharge pressure. An additional recirculation line with a hand-operated valve is frequently provided to permit fuel oil to be circulated through a FO-service-system heater and a boiler's burner manifold prior to lighting-off the boiler. To prevent FO-service-system overpressurization, a relief valve should always be installed on the discharge side of each FO service pump.

Remote controls are typically provided that enable a vessel's FO service pumps to be stopped in an emergency from outside of the machinery space. In addition, flanged FO-service-pump discharge connections are ordinarily fitted with wrap-around shields to deflect spray in case of a leak. In addition, a drip pan or similar device is usually installed under a FO service pump to prevent oil that may leak out of the pump from draining into a vessel's bilge.

**LUBRICATING-OIL SERVICE PUMPS** A lubricating-oil service (LOS) pump removes lubricating oil from the propulsion-reduction-gear sump and discharges it to the propulsion-turbine bearings, the reduction gears and their bearings, and the main thrust bearing for each propulsion shaft. This oil is also usually directed to the inlet side of a speed-limiting governor pump mounted on the forward end of each propulsion turbine's shaft and to the propulsion-turbine throttle- or nozzle-valve controls. In addition, a portion of the pumped oil may be sent to an overhead gravity tank that holds enough oil to lubricate the propulsion machinery for several minutes following a loss of LOS-pump discharge pressure.

Most steam-powered vessels have two or three LOS pumps. Horizontally and vertically mounted multiple-screw pumps are frequently used. When mounted vertically, the pumps may be submerged directly within the lubricating-oil (LO) sump. In most cases, at least one rotary LOS pump is electric-motor-driven. Remaining units may also be motor driven, or they may be driven by steam turbines or off the propulsion shafting. In addition, steam-driven reciprocating-piston pumps are sometimes used as standby LOS pumps. In addition, some vessels have a battery-operated emergency LOS pump.

LOS pumps are typically installed low in a vessel and close to the LO sump. Suction and discharge lines are often fitted with duplex strainers. In addition, a relief valve and



coolers are generally installed in pump discharge lines. Also, one or more orifices are typically installed in a LOS system to reduce the pump's full discharge pressure, which is usually based on the requirements of the propulsion-turbine governors and controls, down to the pressure required by the bearings and gears. A pressure-controlled switch or valve that automatically starts a standby pump if the oil pressure at the discharge of the operating LOS pump drops below a preset value is often provided. Most steam-turbine-propelled vessels also have a device that stops the supply of steam to the ahead propulsion turbines in case of a LOS-system failure.

## ***DIESEL-PROPELLED VESSELS***

---

A propulsion diesel engine that operates below approximately 300 rpm and is directly connected to a propulsion shaft is usually classified as a slow-speed engine. Diesel engines that are connected to propulsion shafts through reduction gears and have maximum operating speeds below 900 to 1200 rpm are typically classified as medium-speed engines, and engines that operate above 900 to 1200 rpm and are used with reduction gears are generally classified as high-speed engines.

**ENGINE FRESHWATER COOLING PUMPS** A pump is ordinarily used to circulate freshwater through jackets in a propulsion diesel engine's cylinders and cylinder heads, the engine's turbocharger, and, on some vessels, an evaporator where the jacket water provides heat to produce fresh water. The jacket water may also pass through the engine's lubricating-oil and charge-air coolers. In addition, a heat exchanger in which the jacket water is cooled by either freshwater or seawater is frequently included in the system. Alternatively, this heat exchanger is sometimes eliminated when a vessel has a central freshwater cooling system. Instead, some freshwater from a separate low-temperature loop is admitted into the high-temperature jacket-water loop where it mixes with and cools the hot jacket water. An additional heat exchanger that can be used to preheat the jacket water prior to engine start-up is often provided as part of a main engine's jacket-water system.

The pumps that circulate cooling water through a propulsion diesel engine are frequently called jacket-water circulating pumps. Alternatively, however, they may be referred to as high-temperature freshwater cooling pumps on a vessel that has a central freshwater cooling system. Two vertically or horizontally mounted single-stage centrifugal pumps that are each sized to meet normal full-load requirements are often provided for each propulsion engine. Although each pump may be driven by an electric motor, when used with a high- or medium-speed propulsion engine, one of the pumps is often mounted on and driven off the engine. An elevated tank is ordinarily included in the system to allow for any thermal expansion of the water and to maintain a positive pressure at the pump suction.

Separate electric-motor-driven pumps may be used to circulate fresh water through a propulsion engine's pistons when they are water-cooled. Although single-stage centrifugal pumps are often used in this application, vertical turbine pumps that are submerged in the piston-cooling-water drain tank are used on some vessels. When required by the engine design, an additional pair of electric-motor-driven centrifugal pumps is provided to circulate fresh water through an independent loop that cools the main-engine fuel valves or injectors.

**ENGINE SEAWATER COOLING PUMPS** On some vessels, single-stage centrifugal pumps are used to supply seawater to diesel-engine charge-air, lubricating-oil, and jacket-water coolers. Two pumps that are each sized to meet normal full-load requirements are often provided for each propulsion engine. Although both seawater-cooling pumps may be driven by electric motors, when a medium- and high-speed diesel engine is used, one pump is sometimes attached to and driven by the engine.

**FUEL-OIL SUPPLY AND BOOSTER PUMPS** Fuel-oil (FO) pumps used for diesel engines should be suitable to handle any of the various grades of fuel that may be burned in a vessel's



engines, which can often include both light distillates that are used during maneuvering and heavy residual oils that are used while underway at sea. When heavy fuel oil is supplied to an engine, it must generally be heated to reduce its viscosity.

A FO booster pump typically takes suction either directly from a diesel-propelled vessel's daily service tanks or from a separate mixing tank and supplies fuel oil to the main-engine injector pumps. Two multiple-screw- or gear-type fuel-oil booster pumps that are each capable of meeting full-power requirements are often provided for each propulsion engine. Both FO booster pumps may be electric motor driven. Alternatively, however, when a medium- and high-speed diesel engine is used, one FO booster pump is sometimes attached to and driven by the engine. Also, in some high-temperature heavy-fuel-oil systems, a pair of electric-motor-driven screw- or gear-type FO supply pumps that operate upstream of and in series with the FO booster pumps are located between the service tanks and the mixing tank. More oil is typically delivered to an engine than the amount required for combustion, and the excess oil is ordinarily returned to the service or mixing tank through a recirculation line. Strainers, filters, flow meters, and heaters are also frequently installed in the FO service system.

**LUBRICATING-OIL PUMPS** The main-engine lubricating-oil (LO) pump typically removes lubricating oil from a sump located below a propulsion engine and discharges the oil to the engine's bearings, governor controls, turbochargers, and, when they are cooled by oil, the engine's pistons. Strainers, filters, and a cooler are also usually included in a LO system. Two main LO pumps that are each capable of delivering the oil required during normal full-load engine operation are usually provided for a propulsion engine. Vertically or horizontally mounted multiple-screw and gear pumps are frequently used in this application. Although both pumps may be driven by electric motors, one pump is sometimes attached to and driven off a medium- or high-speed engine. Alternatively, some vessels have electric-motor-driven vertical turbine pumps that are submerged within the LO sump installed. A device that sounds an alarm following a failure of the LO system is normally provided.

When a vessel is propelled by a crosshead-type diesel engine, some of the oil discharged by the main LO pump is often directed to the suction-side of a lower-capacity rotary-type booster pump that supplies oil to lubricate the engine's crosshead bearings. In addition, a separate low-capacity rotary pump is frequently required to fill a head tank that supplies a different grade of oil to lubricators that inject the oil into each of a crosshead engine's cylinders. Also, with some designs, a separate pair of rotary pumps is required to supply lubricating oil to the engine's camshaft bearings.

In addition to the pumps that supply lubricating oil to propulsion engines, separate rotary pumps are generally used to supply lubricating oil to reduction gears and their bearings on vessels propelled by medium- or high-speed engines.

## **GAS-TURBINE-PROPELLED VESSELS**

---

**FUEL-OIL SERVICE PUMPS** Typically, fuel oil is delivered to a propulsion gas turbine's combustion-chamber nozzles by a gear pump that is mounted on and driven by the gas turbine. In addition, a pair of two-speed electric-motor-driven rotary pumps that operate upstream of and in series with the attached pump are usually provided. Duplex strainers, filters, and heaters are also ordinarily included in a gas turbine's fuel-oil service system.

**LUBRICATING-OIL PUMPS** A typical gas turbine is furnished with an attached gear- or centrifugal-type lubricating-oil (LO) pump that is driven off the gas turbine. This pump takes suction from a LO reservoir and discharges synthetic oil to the bearings for the gas turbine and to control devices. Filters are also included in the LO system. In addition, electric-motor-driven gear, vane, or centrifugal pumps are ordinarily used to circulate lubricating oil through the system during start-up and cool-down periods and to serve as a backup to the attached pump. Excess oil delivered by a gas turbine's LO pump is frequently returned through a pressure regulating valve to the LO reservoir. A device is normally provided

that sounds an alarm and, in some cases, automatically stops the flow of fuel to a gas turbine following a failure of the LO system.

Separate rotary scavenge pumps may be used to return oil that drains from a gas turbine's bearings to the LO reservoir. In addition, multiple-screw pumps are frequently used to circulate mineral oil through an independent lubrication system for a gas-turbine-propelled vessel's reduction gears and their bearings. Although one of these screw pumps may be driven off the reduction gears, the remaining reduction-gear LO pumps are usually electric motor driven. Some of the mineral oil in the reduction-gear LO system frequently passes through a heat exchanger in which it absorbs heat from the synthetic oil that lubricates the gas turbine's bearings. The reduction-gear lubricating oil also usually passes through a second heat exchanger in which it is cooled either by freshwater or seawater.

## **GENERATOR APPLICATIONS**

---

### ***Steam-Turbine-Driven Turbogenerators***

**AUXILIARY CONDENSATE PUMPS** When the steam leaving a steam ship's turbogenerator exhausts into an auxiliary condenser, an auxiliary condensate pump is ordinarily used to remove condensate from the auxiliary condenser's hotwell and return it to the DFT. A typical auxiliary condensate pump is a vertical two-stage centrifugal pump that is similar in configuration to a main condensate pump but is smaller in size. One auxiliary condensate pump is typically furnished for each auxiliary condenser. Crossover lines are, however, often provided so each auxiliary condensate pump on a vessel can remove condensate from any of the vessel's auxiliary condensers.

**AUXILIARY CIRCULATING PUMPS** A single-stage centrifugal pump is often used to circulate seawater through the tubes of an auxiliary condenser that receives steam exhausted from a vessel's turbogenerator. Seawater discharged by this pump may also be directed to the generator's lubricating-oil and air coolers. One auxiliary circulating pump is typically furnished for each auxiliary condenser. Crossover lines, however, are often provided so one generator's auxiliary circulating pump can supply seawater to any of the vessel's auxiliary condensers. In addition, a line is often installed that permits seawater discharged from a vessel's auxiliary circulating pumps to be directed, in case of a main circulating pump failure, to a main condenser.

**LUBRICATING-OIL PUMPS** A typical turbogenerator is fitted with an internal or external gear-type lubricating-oil (LO) pump that is geared to and driven by the turbine. The pump ordinarily takes its suction from a sump located below the turbine's reduction gears and discharges lubricating oil to bearings, the turbine's reduction gears, and the governor that controls the flow of steam to the turbine. A separate hand-operated or electric-motor-driven gear pump may also be provided to enable lubricating oil to be circulated through the LO system during generator start-up and shutdown periods.

A duplex strainer, a cooler, and one or more relief valves are often included in a turbogenerator's LO system. In addition to protecting the system from overpressurization, the relief valves act as backpressure valves that maintain the desired LO pressure in various parts of the system. This arrangement permits lubricating oil sent to the governor to be at a higher pressure than the oil directed to bearings and reduction gears. A turbogenerator is ordinarily fitted with a trip that stops the flow of steam to the turbine if the LO pressure drops below a preset value.

## **DIESEL-DRIVEN GENERATORS**

---

**JACKET-WATER CIRCULATING PUMPS** A diesel engine that drives a generator is often furnished with an attached centrifugal-type jacket-water circulating pump that circulates

freshwater through passages in the engine's cylinders and cylinder heads, the engine's turbocharger, and the engine's lubricating-oil cooler. In addition, the jacket-water system may include a preheater that is used to warm-up the water prior to engine start-up. When the jacket water is air cooled, it will also pass through a radiator. Alternatively, the jacket water may be cooled by seawater or freshwater in a heat exchanger. When seawater is used as the cooling medium in a jacket-water cooler, the seawater may be circulated by a centrifugal pump that is attached to and driven by the diesel engine or by a separate electric-motor-driven centrifugal pump.

**FUEL-OIL PUMPS** A diesel engine that drives a generator frequently has an attached rotary gear-type fuel-oil (FO) pump that is mounted on and driven by the engine. The pump typically takes suction from a daily service tank and delivers fuel oil to the engine's injector pumps. Excess oil delivered to the engine is ordinarily returned through a recirculation line to the service tank. A filter is typically included in the system. A separate hand-operated FO pump that can be used to prime the engine-driven FO pump (for example, following maintenance performed on the FO system, such as filter replacement) may also be provided. A diesel engine's FO supply line is often fitted with a valve that can be closed from outside the machinery space to stop the engine in case of a fire or other emergency.

**LUBRICATING-OIL PUMPS** A diesel engine that drives a generator is usually fitted with an attached rotary gear-type lubricating-oil (LO) pump that is mounted on and driven by the engine. The pump typically takes suction from a sump located below the engine and discharges oil to the engine's bearings. A filter and cooler are also ordinarily included in an engine's LO system. In addition, a hand-operated or air-motor-driven rotary-type LO pump is often provided to permit the engine's bearings to be prelubricated prior to startup. A diesel engine that drives a generator is often protected by a trip that stops the engine if the pressure in the LO system drops below a preset value.

## **AUXILIARY APPLICATIONS**

---

### ***Ship's Service Pumps***

**FUEL-OIL TRANSFER PUMPS** A fuel-oil (FO) transfer pump is used to remove fuel oil from one or more of a vessel's FO storage tanks and to transfer the oil to settling tanks, to other storage tanks (that is, to adjust the list, trim, or stability of the vessel), or to an above-deck connection through which the oil can be directed ashore or to another vessel. Most vessels have at least two pumps that can be used to transfer fuel oil. Although horizontally and vertically mounted multiple-screw rotary pumps are frequently used in this application, steam-driven reciprocating-piston pumps are sometimes used to transfer fuel oil. FO transfer pumps are often installed low in a vessel to improve suction conditions.

Some rotary FO transfer pumps are driven by two-speed electric motors or steam turbines. When this is the case, the capacity of fuel transferred can be changed by altering the speed of the transfer pump's driver. The capacity delivered by a FO transfer pump during constant-speed operation can often be reduced by opening a valve in a bypass line through which a portion of the oil discharged by the pump is recirculated back to the suction line. A FO transfer pump is usually protected with a suction strainer and a discharge relief valve and is often fitted with remote controls that enable the pump to be stopped from outside of a vessel's machinery spaces.

On a steam-propelled vessel with oil-fired boilers, a FO service pump typically takes suction directly from the fuel-oil settlers and discharges oil to burners in the vessel's boilers. On a diesel-propelled vessel, however, fuel oil in the settlers is ordinarily passed through one or more purifiers as it is transferred to separate daily service tanks from which the engine FO supply or booster pumps take suction. The rotary gear-type pump that frequently delivers fuel oil to a purifier is often mounted on and driven by the purifier. In some cases, a second attached rotary pump is used to boost the pressure of the clean

oil leaving a purifier. Alternatively, independent electric-motor-driven pumps are sometimes used with FO purifiers.

**FRESHWATER COOLING PUMPS** To reduce corrosion from seawater, some vessels are fitted with a central freshwater cooling system. When this is the case, single-stage centrifugal pumps are generally provided to circulate freshwater through two separate cooling loops: a low-temperature loop and a high-temperature loop. Two centrifugal pumps that are each capable of delivering the full-load capacity are frequently installed in each freshwater loop. Smaller pumps may also be provided for startup and in-port use.

A low-temperature freshwater cooling pump ordinarily circulates freshwater through a vessel's various condensers, oil coolers, and air coolers. Jacket-water coolers for a vessel's auxiliary diesel engines may also be included in the low-temperature loop. In addition, freshwater in the low-temperature loop typically passes through a seawater-cooled heat exchanger. On a diesel-propelled vessel, the high-temperature freshwater cooling pump serves as the jacket-water-circulating pump and typically circulates fresh water through the propulsion-engine jackets, turbochargers, and a freshwater generator (evaporator). On some vessels, freshwater in the high-temperature loop also passes through a heat exchanger in which it is cooled by freshwater in the low-temperature loop. Alternatively, however, the need for this heat exchanger is eliminated in some central freshwater cooling systems with a control valve that allows some of the freshwater in the low-temperature loop to enter, mix with, and cool the hotter water in the high-temperature loop.

**SEAWATER SERVICE PUMPS** A seawater service pump takes suction from a sea chest and supplies seawater to heat exchangers in which this water serves as the cooling medium. This can sometimes include refrigeration and air-conditioning condensers, various lubricating-oil coolers, and air-compressor coolers. On newer vessels that have a central freshwater cooling system, however, the seawater cooling pumps supply seawater only to large freshwater coolers. With either arrangement, after leaving the heat exchangers that it passes through, the seawater is ordinarily directed overboard.

Two or more horizontally or vertically mounted electric-motor-driven single-stage centrifugal seawater service pumps (these pumps are also sometimes referred to as seawater cooling pumps or auxiliary seawater pumps) are usually installed on a vessel. A seawater pump is typically located low in a vessel so it can operate with a flooded suction. In some cases, the pump's suction line may be connected to both a lower sea chest and an upper sea chest. The use of the lower sea chest, which often receives seawater through an opening in the bottom of a vessel's hull, reduces the potential for air to enter a seawater pump's suction line (especially when the vessel is rolling in rough seas). However, when the vessel is in shallow water, using the upper sea chest, which is typically connected to an opening in the side of a vessel's hull, can reduce the amount of silt, mud, and other contaminants entering the seawater-pump suction. In addition to the sea-chest connections, on a diesel-propelled vessel, the largest seawater-cooling pump may also have an emergency bilge suction line through which the machinery space can be dewatered in case of flooding.

To help protect a seawater pump from foreign material that may enter a sea chest, a strainer is frequently installed in a seawater pump's suction line. In addition, when a mechanical-seal flushing line is used with a seawater pump, it is sometimes fitted with a cyclone abrasive separator. In a typical installation, a recirculation line from the discharge side of the pump's casing is connected to the inlet on the side of the separator. Clean water leaving the top of the separator is directed to the mechanical seal's flushing connection, which is usually in the seal's gland. Dirty water discharged from the bottom of the separator is returned to the suction side of the pump's casing.

**LUBRICATING-OIL TRANSFER PUMPS** Rotary gear pumps are frequently used to transfer lubricating oil from a vessel's lubricating-oil (LO) storage tanks to tanks in various locations throughout the vessel where the oil is stored for use in auxiliary machinery. In addition, a rotary pump may be used to add lubricating oil directly to oil-lubricated machinery.

Most vessels have one or more LO purifiers that can be used to remove water and other contaminants from the lubricating oil contained in machinery LO sumps (for example, LO sumps for diesel engines, turbogenerators, and main-propulsion-turbines). A LO purifier

may also be used to transfer lubricating oil from a vessel's LO storage tanks to separate LO settling tanks. A rotary gear pump is often used to deliver lubricating oil to a LO purifier. In many cases, the pump is mounted on and driven by the purifier. A second attached rotary pump may also be used to boost the pressure of the clean oil leaving a purifier. Alternatively, independent electric-motor-driven pumps are sometimes used with LO purifiers.

**STERN-TUBE LUBRICATING-OIL PUMPS** An electric motor-driven rotary screw, gear, or vane pump is required to circulate lubricating oil through a vessel's stern-lube bearings and seals when these components are oil lubricated. One pump is typically provided for each propulsion shaft. The pressure on the discharge side of a stern-tube lubricating-oil (LO) pump is ordinarily established by the elevation of a head tank that is connected to the system. (Stern-tube LO pumps are not required on vessels that have seawater-lubricated stern-tube bearings and seals.)

**AUXILIARY AND EXHAUST-GAS (WASTE-HEAT) BOILER PUMPS** Diesel-propelled vessels are frequently fitted with exhaust-gas boilers in which heat contained in the engine exhaust-gas is utilized to generate steam for various purposes, such as heating fuel, liquid cargo, and water. On some vessels, a portion of the steam produced may even be superheated and supplied to turbine-driven equipment, such as turbogenerators. To permit steam to be generated during periods of low engine load or when an engine is secured (for example, in port), most of these vessels are also fitted with auxiliary oil-fired boilers that can operate alone or parallel to the exhaust-gas boilers.

In a typical installation, a feed pump is used to return condensate from a drank tank to the boilers. In addition, a separate pump is generally required to circulate water through the boiler generating tubes. Furthermore, when condensing turbines are installed in an auxiliary steam system, a condensate pump is used to transfer condensate from the condenser's hotwell to the drain tank. Electric-motor-driven single and multistage centrifugal and regenerative turbine pumps are typically used in these applications.

A fuel oil (FO) service pump is usually required to supply fuel oil to an oil-fired auxiliary boiler. Electric-motor-driven gear pumps are often used in this application.

**HYDRAULIC-SYSTEM PUMPS** Positive-displacement pumps are ordinarily used to pressurize and circulate the hydraulic fluid in a vessel's hydraulic systems. Typical examples of shipboard hydraulically powered machinery include steering gear, anchor windlasses, cranes, hatch covers, and valves. The hydraulic pumps, which can be installed in a self-contained system that is an integral part of the hydraulically powered component or in a larger central system that provides fluid to all of the hydraulic equipment on a vessel, are usually driven by electric motors or diesel engines.

In a constant-pressure hydraulic system, one or more variable-displacement rotating-piston pumps are often used to supply hydraulic liquid at essentially a constant pressure to the components that are powered by the system. If the capacity delivered by a pump exceeds the system's demand, the pump discharge pressure will include and an automatic controller will reduce the pump's stroke and the capacity pumped until the discharge pressure returns to the set point. If the system demand increases and the pump discharge pressure drops, the pump's stroke and the capacity delivered will be increased. The pump stroke and the pumped capacity are, therefore, automatically adjusted to match the demand on the hydraulic system. In some systems, hydraulic pumps may also be automatically started and stopped as needed.

The hydraulic fluid in a constant-flow variable-pressure hydraulic system is typically circulated by gear, vane, multiple-screw, or fixed-displacement rotating-piston pumps. These pumps, which often operate continuously, take suction from a sump or tank and deliver pressurized oil to the components powered by the system. If the capacity delivered by a system's pumps exceeds the system requirement, excess oil is recirculated through an unloading valve back to the sump.

**FIRE PUMPS** A fire pump takes suction from a vessel's sea chest and discharges seawater through a fixed fire main to hydrants located throughout the vessel. Most vessels have at least two fire pumps that are each capable of delivering a minimum capacity of seawater

simultaneously to a specified number of the most remote hydrants at a specified pressure. Although fire pumps are sometimes used for other purposes, at least one fire pump on a vessel should always be available to provide water to the fire main. In addition, some of a vessel's fire pumps, together with their sea connections and sources of power, are ordinarily installed in separate spaces and arranged so a fire in any one location cannot incapacitate all of the vessel's fire pumps. Also, controls are sometimes provided that enable a fire pump's suction and discharge valves to be opened and the pump to be started from outside of the machinery space. A pressure gage and a relief valve are usually installed in a fire pump's discharge line. (See Section 9.4.)

Single-stage and, in some cases, two-stage centrifugal pumps may be used in fire service. Vertically mounted centrifugal fire pumps are generally driven by electric motors. Horizontal fire pumps, however, can be driven by electric motors, steam turbines, or diesel engines. In addition, smaller centrifugal fire pumps and the electric motors that typically drive them are sometimes furnished in a close-coupled configuration. A centrifugal fire pump is ordinarily installed low in a vessel so it operates with a flooded suction. Alternatively, a vertical turbine pump is sometimes used in this application, which enables the fire-pump impellers to be submerged within a tank.

Some vessels also carry portable fire pumps that can be moved throughout the vessel by the crew. A typical portable unit consists of a single-stage end-suction centrifugal pump that is close-coupled to a gasoline engine. An integral vacuum priming pump is often included with a portable unit to enable the fire pump to be used in areas of the vessel that are above the waterline.

**BILGE PUMPS** Bilge pumps remove liquid from machinery-space bilges, tank tops, the shaft alley, and watertight compartments located throughout a vessel. Fluid discharged from a bilge pump is typically directed, depending on its content and applicable regulations, to an oily-waste holding tank or overboard. Most vessels have more than one bilge pump. In addition to a common suction main that is connected to branches that lead to suction wells (sometimes referred to as rose boxes) located throughout a vessel, one or more independent bilge-pump suction lines are generally provided in machinery spaces. In addition, a vessel's bilge pumps, together with their sources of power, may be installed in various watertight compartments throughout a vessel so the flooding of one compartment will not incapacitate all of the vessel's bilge pumps. Alternatively, some vessels have an emergency bilge pump that is suitable for use even when the pump is submerged. The submersible bilge pump, which is normally powered through the vessel's emergency switchboard, can normally be operated remotely from outside of the vessel's machinery spaces.

Horizontally and vertically mounted centrifugal pumps are frequently used for bilge service. Centrifugal bilge pumps are frequently driven by electric motors. Some bilge pumps, however, are driven off a vessel's propulsion machinery. Because bilge pumps frequently operate with a suction lift, a non-self-priming centrifugal bilge pump is usually connected to a vacuum-priming pump. The vacuum pump can be part of a central system that is used to prime multiple pumps on a vessel (Figure 9), or it may be a dedicated unit that is used only with the bilge pump. When a dedicated vacuum pump is provided, it is sometimes electric-motor-driven and mounted on the same baseplate as the bilge pump that it primes. Alternatively, a dedicated vacuum pump may be mounted on and driven directly off the bilge pump.

To eliminate the need for a separate priming pump, self-priming centrifugal pumps are sometimes used in bilge service. A typical self-priming centrifugal pump (Figure 10) has a casing with an enlarged suction chamber that retains liquid whenever the unit is stopped. When the pump is started with air in its suction line, the liquid in the suction chamber is pumped through the impeller and enters a discharge chamber installed at the top of the casing. The evacuation of the suction chamber creates a vacuum that draws air from the suction line into the pump. The liquid in the discharge chamber is returned to the pump's impeller through either an internal port or an external recirculation line and mixes with this air. The liquid-and-air mixture is then pumped through the impeller and into the discharge chamber where the air is vented from the pump. The liquid is again returned to the impeller, and the cycle is repeated. Each time the stored liquid is recirculated through the pump, an additional amount of air is removed from the suction line.



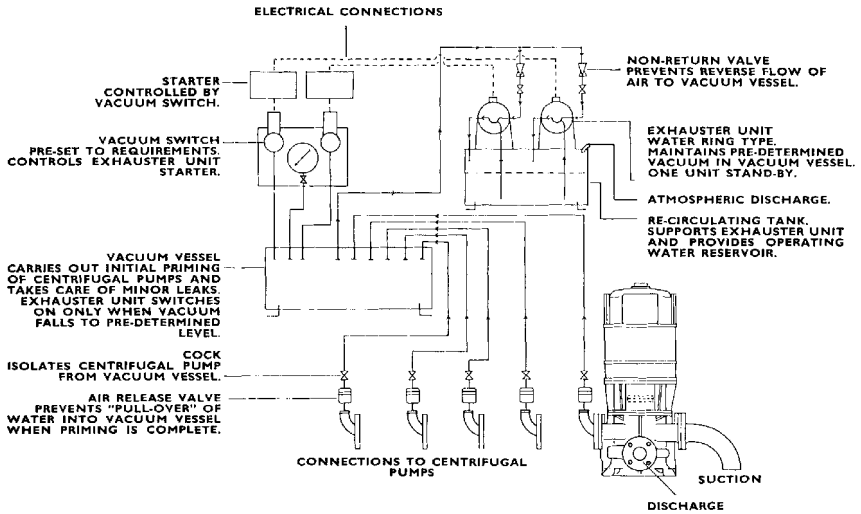


FIGURE 9 Central priming system (Flowserve Corporation)

- 1 Casing
- 2 Suction chamber
- 3 Recirculation port
- 4 Impeller
- 5 Discharge chamber
- 6 Shaft
- 7 Impeller nut
- 8 Impeller-nut insert
- 9 Gland
- 10 Packing
- 11 Lantern ring (seal cage)

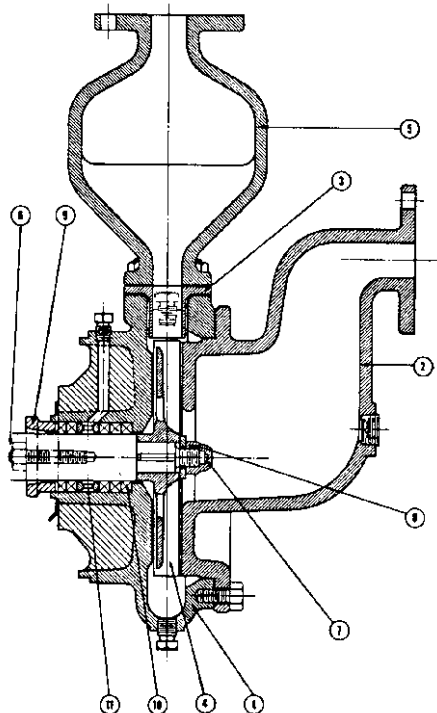


FIGURE 10 Self-priming centrifugal pump (Flowserve Corporation)

After this occurs, the pump will discharge liquid in a normal fashion. However, priming times can be excessive when large amounts of air must be removed from a suction line; consequently, self-priming centrifugal pumps are usually only used for bilge service when the length of the bilge suction piping is relatively short.

Additional types of bilge pumps that do not require priming pumps include motor-driven sump pumps that are submerged within the bilge drain wells; rotary-type vane pumps; air-operated diaphragm pumps; and motor-, steam-, or air-driven piston-type reciprocating pumps.

An oily-water separator (OWS) is used to remove oil from bilge water so the water can be discharged overboard. A typical OWS is fitted with one or more dedicated pumps that take suction either from an oily-water holding tank or directly from bilge suction wells and circulate the oily water through the separator, discharge clean water overboard, and transfer separated oil to a waste-oil tank. Electric-motor-driven progressing-cavity pumps are often used with an OWS.

**BALLAST PUMPS** A ballast pump is used to transfer seawater into and out of a vessel's ballast tanks to adjust list, trim, draft, and stability. Ballast pumps may also be used during a voyage to exchange water contained within ballast tanks to prevent the introduction of nonindigenous aquatic species into coastal and inland waterways. A ballast pump must, therefore, have the capability to take suction either from a sea chest or from ballast tanks that are being emptied. In addition, it must be possible to direct seawater discharged by a ballast pump either to ballast tanks that are being filled or overboard. Furthermore, the seawater discharged by a ballast pump may be used as the motive fluid in eductors that are provided to strip ballast tanks. On some vessels, pumps used for ballasting and deballasting may also be used for other purposes, such as bilge dewatering (that is, a bilge and ballast pump) or fire fighting. Vessels with large segregated ballast tanks, such as many tankers, however, frequently have dedicated ballast pumps.

Horizontally and vertically mounted single-stage centrifugal pumps that are installed in a vessel's machinery space are often used for ballast service. Although many of these pumps are driven by electric motors, larger ballast pumps are sometimes driven by steam turbines. A centrifugal ballast pump is normally located low in a vessel so it will operate with a flooded suction when it is lined up to the sea chest or begins to empty a ballast tank that is full. As the water level in a ballast tank being emptied drops, however, the submergence of the pump's impeller is continuously reduced. To enable it to be reprimed if suction is lost prematurely during operation with a suction lift, a centrifugal ballast pump may be connected to a priming system.

As an alternative to centrifugal ballast pumps installed in a machinery space, hydraulic-motor-driven centrifugal ballast pumps that are submerged directly in the ballast tanks are used on some vessels. In addition, some vessels have vertical line-shaft deep-well ballast pumps. So the pump can take suction from multiple locations, a deep-well ballast pump is frequently installed in a suction can that is connected to the ballast-system suction piping. To enable air and vapor to be removed from the can and suction piping, a deep-well ballast pump is often fitted with self-priming valves.

## **HOTEL SERVICE PUMPS**

---

**FLASH-DISTILLING-PLANT PUMPS** Many steam ships have multistage flash distilling plants that are used to generate freshwater from seawater. Several electric-motor-driven single-stage centrifugal pumps are used with a typical flash unit. Smaller pumps are often provided in a close-coupled configuration.

A distiller-feed pump takes suction from a sea chest and supplies seawater to the distilling plant's first-stage flash chamber. This water often passes through various heat exchangers, such as a distillate cooler, distillate condensers, air-ejector condenser, and seawater heater before it enters the flash chamber. The distiller-feed pump is usually located sufficiently below the vessel's waterline so it operates with a flooded suction.

The hot high-salinity brine remaining in a flash distilling plant's last stage is typically removed by a brine pump that discharges it overboard. A line is often provided to permit



a brine pump's shaft seals to be flushed with seawater discharged from the distiller-feed pump. In addition, a vent line is typically connected from a brine pump's suction to the last-stage flash chamber.

The freshwater or distillate produced by a flash distilling plant is removed from the last-stage distillate condenser by a distillate pump. During normal operation, water discharged from this pump ordinarily passes through a cooler and is then directed to a vessel's distilled-water (reserve-feedwater) or potable-water tanks. A salinity cell in the pump discharge line, however, will typically trip a three-way valve that dumps the distillate to the bilge if salinity of this water is excessive. A vent line may be connected from a distillate pump's suction to the last-stage distillate condenser.

An additional pump is sometimes provided to remove condensate from the hotwell of a flash distilling plant's seawater heater and transfer it to a freshwater drain tank. Alternatively, however, this condensate may be returned directly to a main or auxiliary condenser through a vacuum-drag line. With this latter arrangement, the feed-heater condensate pump is not required.

Because the distillate, brine, and feed-heater condensate pumps each take their suction from a chamber in which the pumped liquid is at or near its vapor pressure, pumps used in these applications should have low *NPSH* requirements. In addition, to increase the submergence of their impellers, these pumps are often located as far below the distilling plant assembly as practicable.

**HEAT-RECOVERY DISTILLING-PLANT PUMPS** It is common for a diesel-propelled vessel to be fitted with one or more heat-recovery distilling plants in which jacket water from the vessel's diesel engines serves as the heating medium. In a typical heat-recovery distilling plant, this jacket water is pumped through either a plate or a submerged-tube evaporator.

Seawater is often delivered to a heat-recovery distilling-plant by a dedicated distiller-feed pump (sometimes referred to as an eductor or ejector feed pump) that takes its suction from a sea chest. In some units, this seawater initially passes through the distilling plant's condenser where it absorbs heat from the distilled vapor generated in the evaporator. A portion of this seawater then enters the evaporator section of the shell as feed. The remaining portion of the seawater frequently serves as the motive fluid for an eductor that removes brine from the evaporator and air from the condenser portion of the distilling plant's shell. After leaving the eductors, this seawater is directed overboard with the brine and air. (In some units, the mixture of seawater, brine, and air passes through the distilling plant's condenser before being discharged overboard.) The feed pump is typically located low in a vessel to enable it to operate with a flooded suction.

A distillate pump is used to remove the freshwater collected in a heat-recovery distilling plant's condenser and discharge it either to the vessel's freshwater tanks or, when the salinity is high, to the bilge. Both the eductor-feed pump and the distillate pump are generally electric-motor-driven single-stage centrifugal-type pumps. In addition, they are often furnished in a close-coupled configuration.

**POTABLE-WATER PUMPS** A potable-water pump typically takes suction from a vessel's potable-water or domestic tanks and discharges freshwater either directly to sinks, showers, and other potable-water fixtures located throughout the vessel or to an air-charged pressure tank, sometimes referred to as a hydrophore or a hydropneumatic tank, that is frequently included in a potable water system. Most vessels have at least two full-capacity potable-water pumps. Electric-motor-driven single-stage centrifugal pumps are often used in this application. In addition, regenerative turbine pumps are sometimes used. Smaller pumps are often furnished in a close-coupled configuration. To improve suction conditions, a potable-water pump may be installed as far as practicable below a vessel's potable water tanks.

In a typical potable-water system in which a hydrophore is connected to the pump discharge line, a potable-water pump may be cycled on and off automatically by a pressure switch installed on the hydrophore. During periods when the pump is not running, any potable-water usage will result in a drop of the water level within the hydrophore, the expansion of the compressed air located in the upper portion of this tank, and a reduction in the hydrophore pressure. However, the force exerted by the compressed air ordinarily

prevents the potable-water system pressure from dropping too suddenly. If the potable-water usage continues, the pressure exerted by the compressed air within the hydrophore will continue to drop until it reaches the cut-in pressure for the potable-water pump's motor. At this point, the pump will be started and the water level and pressure within the hydrophore will normally increase. This will continue until the pressure switch's cut-out pressure is reached and the potable-water pump is stopped.

Although it is less common, on a vessel with a high potable-water demand, a potable-water pump may be operated continuously. When a potable-water pump operates continuously, however, a recirculation line is typically provided to prevent the pump from overheating during periods of low water usage.

**HOT-WATER CIRCULATION PUMPS** Some of the freshwater discharged from a vessel's portable-water pumps is circulated through a heater and is then directed to sinks, showers, and other hot-water fixtures located throughout a vessel. One or more hot-water circulation pumps are ordinarily used to recirculate unused water contained in the hot-water distribution piping through the heater so the water will remain hot. Electric-motor-driven single-stage centrifugal pumps are typically used in this application. In addition, most hot-water circulating pumps, which generally operate continuously, are furnished in a close-coupled configuration.

**SANITARY PUMPS** Seawater is sometimes used as the flushing medium in bathrooms on a vessel. When this is the case, a sanitary or flushing-water pump may be provided to take suction from a sea chest and discharge seawater to the vessel's flushometer valves. Two electric-motor-driven single-stage centrifugal pumps are frequently used in this application. When each pump is sized to meet peak-demand requirements, one pump can be cycled on and off automatically by a discharge-pressure switch while the second pump serves as a standby unit. To reduce the number of sanitary-pump starts and stops, an air-charged pressure tank similar to the potable-water-system hydrophore described previously is often included in a sanitary system. A sanitary pump is frequently located low in a vessel so it can operate with a flooded suction.

**SEWAGE PUMPS** When a vessel has a sewage holding tank, a sewage pump typically takes suction from the holding tank and discharges the sewage and waste water, based on applicable regulations, overboard or to an above-deck connection for transfer ashore. Electric-motor-driven single-stage centrifugal pumps are frequently used in this application. Some of these pumps have casings with large waterways and are fitted with special non-clog impellers. Alternatively, some vessels have sump-type centrifugal pumps that are submerged within the sewage tank and are driven by submersible motors or through vertical line shafting by above-tank motors. With either arrangement, two pumps are often provided for each holding tank.

Instead of a sewage holding tank, many vessels now have an onboard sewage treatment plant, referred to as a marine sanitation device (MSD). At least two pumps are ordinarily provided with each MSD to discharge the treated effluent overboard. Standard electric-motor-driven single-stage centrifugal pumps are frequently suitable for this purpose.

Some vessels also have one or more lift stations in which sewage and wastewater is collected before being transferred to an MSD or a larger sewage holding tank. Macerator pumps are frequently used to transfer a lift station's contents to the MSD or holding tank. A macerator grinds the sewage and breaks up solids into small particles that are more easily treated. Lift-station transfer pumps are usually started and stopped automatically by a float switch in the lift station. Two pumps are often provided for each lift station.

**AIR-CONDITIONING CHILLED-WATER PUMPS** Some vessels utilize freshwater as a secondary refrigerant for air conditioning. With this arrangement, a chilled-water pump circulates the fresh water through a chiller where it is cooled by the system's primary refrigerant. The water then passes through duct-mounted cooling coils, where it absorbs heat from air being supplied to temperature-controlled spaces located throughout the vessel. The chilled water may also be used to cool electronic components. Electric-motor-driven single-stage centrifugal pumps are frequently used in this application. A pressurized or elevated

expansion tank that is typically installed on the suction side of the system maintains a minimum pressure at the inlet to the pumps.

## **CARGO PUMPS AND ASSOCIATED PUMPS**

---

Cargo pumps are used to discharge the liquid cargo transported in a vessel's tanks. The types of vessels that carry liquid bulk cargo include ultra-large and very-large crude carriers (ULCC's and VLCC's), multi-petroleum product and chemical carriers, and liquefied natural gas (LNG) and liquefied petroleum gas (LPG) carriers. In addition, some freighters and supply vessels have tanks in which they can carry a limited amount of liquid cargo.

As liquid cargo is discharged from a vessel, the level in a cargo tank being emptied and, therefore, the suction head to the cargo pump are continuously reduced. This, as well as the fact that many cargoes have relatively high vapor pressures, means cargo pumps must often operate with relatively low values of available net positive suction head (*NPSH*). In addition, as a cargo tank is being emptied, vortices can form on the surface of the liquid in the tank, and air or inert gas (the space in a cargo tank above a flammable liquid is typically filled with inert gas) from the tank's atmosphere can be drawn through a vortex and into the cargo pump's suction. To reduce the potential for cavitation and vortex formation, the flow rate discharged by a cargo pump is frequently reduced by the use of either manually controlled or motorized remote-operated discharge valves during the latter stages of a pump-out cycle.

The materials used in the construction of a cargo pump's wetted components must be compatible with all of the fluids that the pump will discharge. In addition to the cargoes that the vessel will carry, this can also include seawater if the cargo pumps will be used to remove slops during tank washing. In addition, if fluids that are flammable or explosive will be pumped, components with contacting surfaces should be constructed from non-sparking materials.

A description of some of the different types of pumps used in marine cargo service follows.

**CENTRIFUGAL CARGO PUMPS** Single-stage centrifugal pumps are used to discharge liquid cargo on many crude-oil carriers. In addition, they are used on some large product carriers that transport a limited number of different liquid cargoes. Typically, three or four centrifugal cargo pumps are installed in one or more pump rooms located low in a vessel. Each pump can frequently remove cargo from multiple tanks through interconnected suction piping.

A centrifugal cargo pump may be furnished with a double-suction impeller mounted in a between-bearings configuration (Figure 11). Pumps of this type, which must be fitted with two shaft seals, are installed in both horizontal and vertical configurations. Alternatively, a vertically mounted centrifugal cargo pump design with an impeller that is overhung on the end of a shaft (Figure 12) is used on some vessels. This latter configuration enables both of the pump's external bearings and the single shaft seal to be located above the impeller, which facilitates maintenance. A centrifugal pump's bearing housings are often fitted with explosion-proof intrinsically safe resistance temperature detectors (RTDs) that permit the operator to detect a hot bearing before it leads to a serious casualty. In addition to the suction and discharge connections, one or more vents are often provided in the suction area of a centrifugal cargo pump's casing so vapor and gas mixed with the liquid entering the pump during a pump-out can be removed from the casing.

Although centrifugal cargo pumps are frequently driven by steam turbines, they are also sometimes driven by diesel engines or electric motors. To isolate it from the explosive vapor that is often present in a pump room, a centrifugal cargo pump's driver is usually installed in a separate machinery space located adjacent to the pump room. With this arrangement, each driver is typically flexibly coupled to the cargo pump that it drives through an intermediate jackshaft. The opening in the pump-room bulkhead (for a horizontal pump, Figure 13a) or overhead (for a vertical pump, Figure 13b) through which the jackshaft passes is ordinarily sealed with a gas-tight stuffing box to prevent explosive

- |   |                             |    |                        |
|---|-----------------------------|----|------------------------|
| 1 | Casing                      | 7  | Bearing housings       |
| 2 | Shaft                       | 8  | Line bearing           |
| 3 | Casing wearing ring         | 9  | Auxiliary stuffing box |
| 4 | Impeller                    | 10 | Shaft nut              |
| 5 | Vent / stripping connection | 11 | Mechanical seal        |
| 6 | Thrust bearing              | 12 | Impeller wearing ring  |

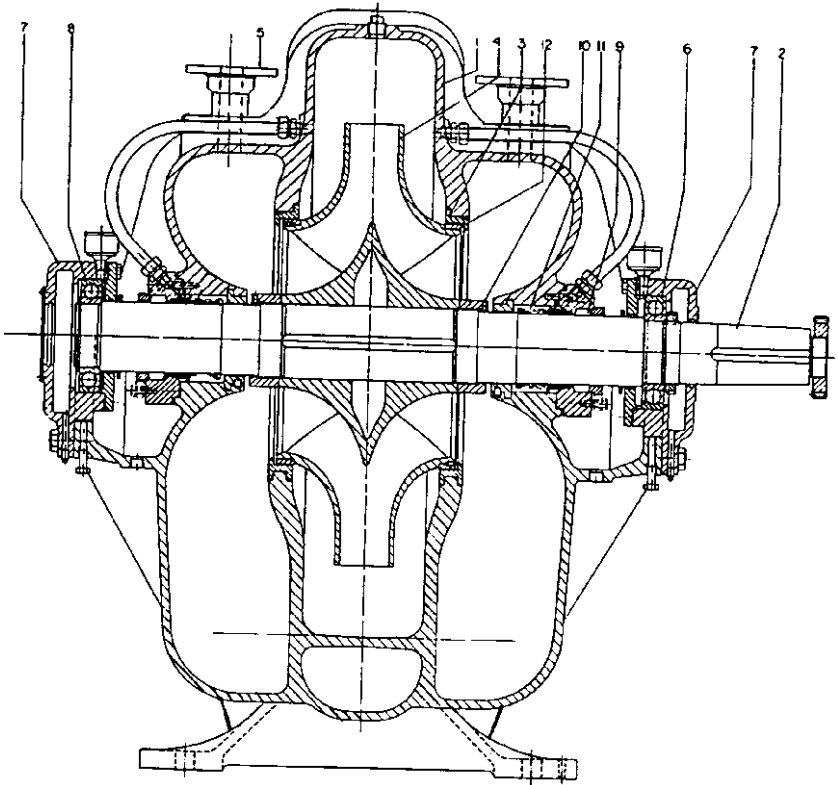


FIGURE 11 Between bearings centrifugal cargo pump (Flowsolve Corporation)

vapor in the pump room from entering the machinery space. A thrust bearing is also frequently provided in the driver to support the weight of a jackshaft used with a vertically mounted cargo pump.

As the liquid level in a cargo tank being emptied approaches the inlet to the suction tailpipe (referred to as a suction strum), air or inert gas from the tank's atmosphere can be drawn into the cargo pump through vortices that form on the surface of the liquid. This entrained gas can cause a centrifugal cargo pump to lose suction before the cargo tank has been emptied. Although a separate stripping pump may then be used to remove the liquid remaining in the cargo tank, stripping pumps typically deliver much lower capacities than large centrifugal cargo pumps. Therefore, self-priming/stripping systems are sometimes employed to increase the amount of cargo that can be discharged by a centrifugal cargo pump. A recirculation-priming system and an automated-vacuum-stripping system are two types of systems that are used.

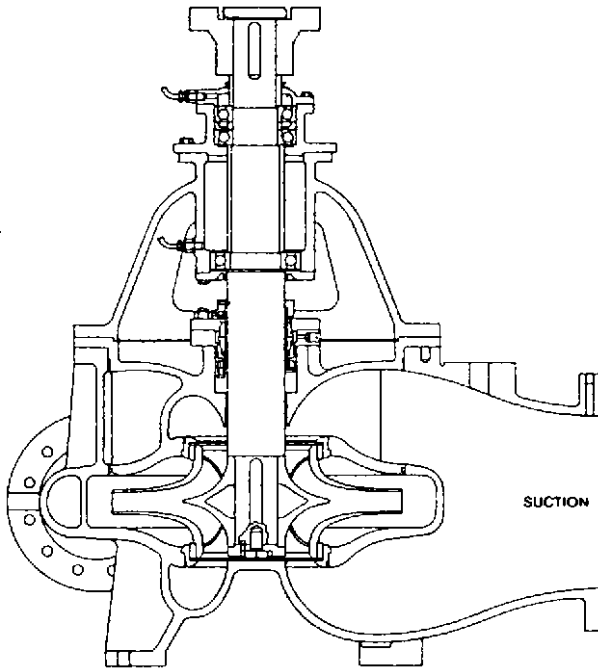


FIGURE 12 Vertical overhung centrifugal cargo pump (FlowsERVE Corporation)

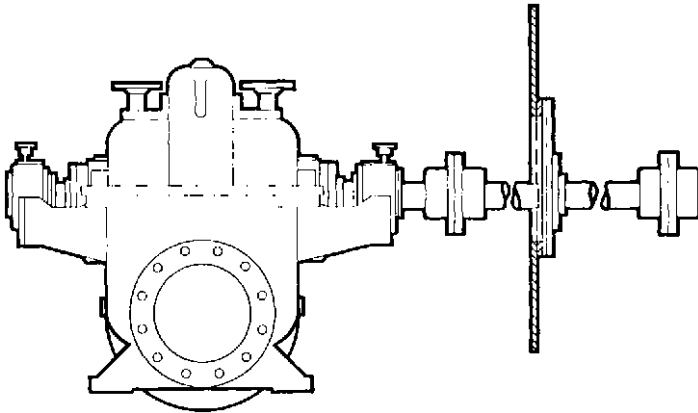
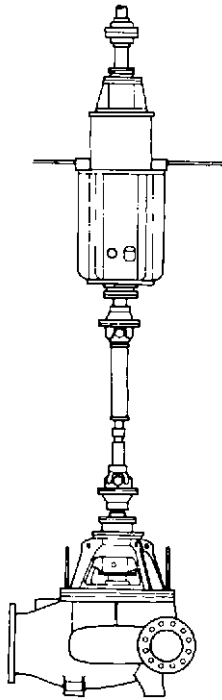


FIGURE 13A Horizontal centrifugal cargo pump with jackshaft (FlowsERVE Corporation)

In a typical recirculation-priming system, a recirculation tank is mounted between the cargo-system suction piping and the inlet to the cargo pump. In addition, one or more priming valves are mounted in the cargo discharge line near the outlet from the pump. Also, a recirculation line is connected from these valves back to the recirculation tank at the pump's inlet, a check valve is installed in the cargo-pump discharge piping above and



**FIGURE 13B** Vertical centrifugal cargo pump with jackshaft (Flowserve Corporation)

downstream from the priming valves, and a vent line with a second check valve is connected from the top of the recirculation tank to the cargo-pump discharge line just upstream of the discharge check valve. A branch from the recirculation tank's vent line is ordinarily piped to the vent/stripping connections in the cargo pump's casing.

At the beginning of a pump-out, the recirculation tank is filled with liquid cargo and the priming valves are closed. However, if, as the level in the cargo tank being emptied is reduced, the percentage of gas in the liquid being transferred increases sufficiently for the cargo pump to lose suction, the priming valves in the discharge line will open. This permits the cargo contained in the discharge line between these priming valves and the discharge check valve, which closes when the flow through it stops, to be returned through the recirculation line to the recirculation tank. As this liquid drains through the open priming valves, a vacuum is created in the discharge line. The gas contained in the recirculation tank is displaced by the returning liquid and is drawn by the discharge-line vacuum through the vent line and into the portion of the discharge piping that has been evacuated.

As the recirculated liquid cargo enters the recirculation tank, the liquid level within the tank rises until the submergence of the cargo pump's impeller is sufficient for the pump to regain suction. After this occurs, the flow of liquid through the pump will resume, the priming valves and the check valve in the vent line will close, and the gases that have accumulated in the discharge line will be forced through the discharge check valve. The priming cycles will continue until enough gas has been removed from the cargo suction line for the cargo pump to operate normally. As the level in the cargo tank being emptied continues to be reduced, the amount of gas entering the suction strum will increase, and the cargo pump will lose suction more frequently. When the amount of liquid remaining in the cargo tank is not sufficient for the cargo pump to be reprimed, the pump should be stopped.

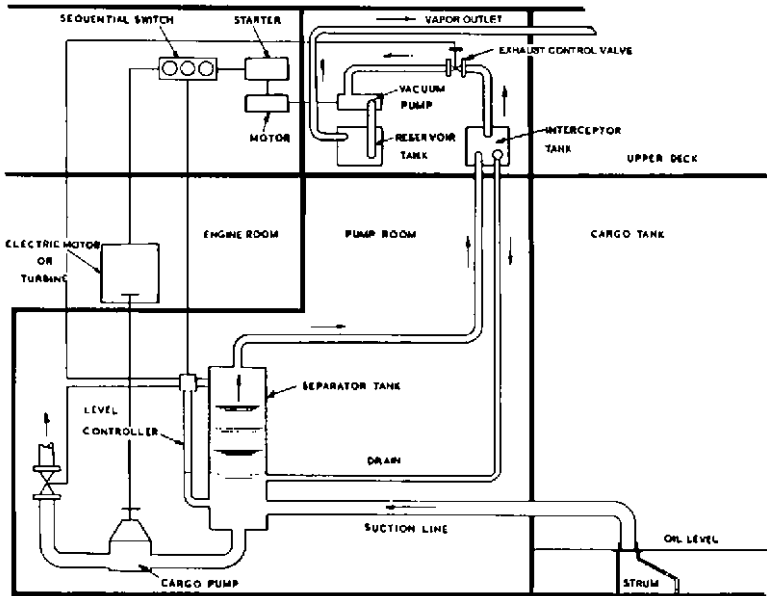


FIGURE 14 Automated-vacuum-stripping system (Flowserve Corporation)

The key components used in a typical automated-vacuum-stripping system (Figure 14) include a separator tank located at the cargo pump's inlet, a vent line connected to the top of the separator tank, an automatic exhaust control valve mounted in the vent line, one or more electric-motor-driven vacuum pumps, a cargo-pump discharge valve with actuator, and associated controls. As with the recirculation system, a branch from the separator tank's vent line is ordinarily piped to the vent connections in the cargo-pump casing.

At the beginning of a pump-out, the separator tank is ordinarily filled with liquid cargo. However, as the pump-out progresses, the liquid level in the cargo tank being emptied and the cargo-pump's suction pressure will both be reduced. Eventually, cargo vapor will typically begin to accumulate in the top of the separator tank and the liquid level in the separator tank will drop. At a specified point, the exhaust control valve in the vent line opens to permit vapor in the separator tank to pass through the vent line before it can enter the cargo pump. If the venting process is not sufficient, the vacuum pump will start and draw vapor out of the separator tank. After the vapor has been removed from the separator tank, the separator-tank liquid level may rise sufficiently for the vacuum pump to stop and the exhaust control valve will, however, reopen and the vacuum pump will restart automatically if, because of the reaccumulation of vapor in the top of the separator tank, the separator tank level again drops. The exhaust control valve will continue to open and close and the vacuum pump will continue to cycle on and off automatically, as needed, based on the level in the separator tank.

With further reductions in the cargo-tank liquid level, the amount of cargo that vaporizes in the cargo-pump suction line and separator tank will increase. In addition, as the cargo-tank liquid level approaches the suction strum, vortices will typically form on the surface of the liquid in the cargo tank and draw gas from the tank's atmosphere into the suction line. As the percentage of vapor and entrained gas in the liquid cargo being unloaded increases, the frequency of the exhaust-control-valve/vacuum-pump cycles described above will increase. Eventually, near the end of the pump-out, it will usually become necessary for the exhaust control valve to remain open and for the vacuum pump to operate continuously.

In addition to operating the exhaust control valve and the vacuum pump, the automated-vacuum-stripping system will normally automatically throttle the cargo pump's discharge valve whenever the vacuum pump is started. In addition, when permitted by the type of driver used, the cargo pump's operating speed may be reduced. Controls may also be included in the system to automatically shut down the cargo pump driver when the pump-out has been completed.

**DEEP-WELL CARGO PUMPS** Vertical line-shaft deep-well pumps are used to discharge liquid cargo on some multi-product and chemical carriers. Therefore, a deep-well cargo pump must frequently be suitable to transfer a wide range of liquids having different specific gravities, vapor pressures, viscosities, and temperatures. Some cargoes, such as lubricating oils, waxes, and other viscous cargoes, may be heated to improve pumpability. With certain cargoes, such as molten sulfur, steam, or a heated liquid may even be circulated through jackets that surround the deep-well pump to prevent the cargo from solidifying within the pump. In addition, deep-well pumps are sometimes used to discharge cryogenic cargoes, such as liquefied petroleum gas (LPG).

A deep-well cargo pump can be driven by a vertical electric or hydraulic motor mounted on top of the pump's discharge head. Alternatively, a deep-well cargo pump may be driven through a right-angle gear mounted on the discharge head by a horizontal motor, steam turbine, or diesel engine. Although a deep-well cargo pump's discharge head is often mounted on a vessel's main deck, on some vessels, the deep-well-cargo-pump discharge heads are located below deck in a pump room. In addition, in some cases, a deep-well cargo pump's horizontal driver is located in an adjacent space and is coupled to the pump's right-angle gear with a jackshaft that passes through a bulkhead separating the pump's discharge head from the driver. The opening for the jackshaft in the bulkhead is ordinarily sealed with a gas-tight stuffing box so the driver can be isolated from any explosive vapor that may be emitted from the pump. Some designs are also available with submersible motors that allow the entire pump-driver assembly to be located at the bottom of the cargo tank.

Many deep-well cargo pumps are furnished with a multistage bowl assembly that has single-suction impellers. When high-vapor-pressure or high-viscosity cargo will be pumped, an inducer is sometimes mounted on the lower end of the bowl assembly's impeller shaft to reduce the pump's net positive suction head requirements. Alternatively, a deepwell pump may be fitted with a special low-NPSH first-stage impeller, or, in some cases, a double-suction first-stage impeller. A spool piece is sometimes installed between the top of a deep-well pump's bowl assembly and the lower end of its column assembly so the bowls can be removed for maintenance while the column and discharge head are still in place.

Hydraulic axial unbalance resulting from the use of single-suction impellers can result in the generation of a high axial thrust. Some deep-well pumps are fitted with a balancing device, such as a balancing drum or front and back impeller wear rings, to reduce this thrust. Alternatively, a thrust bearing is frequently used to absorb the axial thrust acting on a deep-well pump's shaft. This bearing is sometimes installed in a housing that is an integral part of the pump's discharge head. In many cases, however, the thrust bearing is in the vertical driver or right-angle gear (when a horizontal driver is used) that is mounted on top of the pump's discharge head. With this latter arrangement, the deep-well pump's top shaft is typically secured to the vertical driver or gear either with a rigid coupling when the driver or gear has a solid shaft or with an adjusting nut when a hollow-shaft driver or gear is used. It is always important that the pump shaft be raised the proper amount during assembly to prevent contact between the pump's rotating and stationary parts during operation.

Mating sections of a deep-well pump's line shaft are typically connected with threaded or keyed couplings. Radial bearings that support the line shaft are frequently mounted in brackets, sometimes referred to as spiders, that are sandwiched between mating sections of column pipe. Impeller- and line-shaft bearings are often lubricated by the pumped cargo. Consequently, bearing materials must typically be compatible with all of the fluids that will be pumped. The bearings should also be able to tolerate operation with loss of suction if the deep-well pump will be used for stripping or during tank cleaning. Although bronze bearings are common, bearings constructed from carbon, polytetrafluoroethylene (PTFE) compounds, and various composites and plastics have also been used.



The use of a single shaft seal at the location where a deep-well pump's top shaft penetrates the discharge head is sometimes suitable. A multiple sealing arrangement consisting of two packed stuffing boxes or a double mechanical seal may be utilized, however, when a deep-well pump will discharge a volatile cargo. In addition, if a deep-well pump is fitted with a double mechanical seal, a static seal may also be provided to prevent vapor from escaping around the pump's shaft during periods when the mechanical seals are being replaced. A reservoir tank that stores liquid for seal lubrication is often mounted on the side of the discharge head of a deep-well pump that has one or more mechanical seals.

On some multi-product and chemical carriers, a separate deep-well pump is installed in each cargo tank. This arrangement eliminates the need for suction piping, and it can result in a high degree of cargo segregation. On a double-bottom vessel, the deep-well pump's suction opening is frequently submerged in a suction well located in the bottom of the cargo tank. In-tank supports are often provided to stabilize the pump during periods of pitch and roll. However, to prevent these supports from restricting thermal expansion and distorting a pump's column or line shaft as a vessel flexes, they are generally not rigidly attached to the pump.

To prevent fluid in a deep-well pump's discharge head, column pipe, and bowl assembly from draining back into a cargo tank after the pump is stopped, a deep-well cargo pump's inlet opening is sometimes fitted with a nonreturn suction valve (Figure 15). During normal operation, the valve is open. However, after the discharge cycle has been completed, the suction valve closes automatically. The deep-well pump's driver is then stopped, the pump's above-deck discharge valve is closed, and compressed air or inert gas is injected into the pump through a connection in the discharge head. The gas forces the cargo contained within the deep-well pump out through a bypass line connected to the lower portion of the bowl assembly and into the vessel's piping.

On some vessels, such as those that carry either a limited number of different cargoes or cargoes that are not sensitive to contamination, each deep-well pump may be used to discharge cargo from several of the vessel's tanks. When this arrangement is used, each deep-well pump is generally mounted in a suction tank or can that is connected to multiple cargo tanks via suction piping.

A deep-well cargo pump that is installed in a suction can is frequently fitted with automatic priming valves that enable the pump to remove gas and vapor from the can and from the attached suction piping. The operation of these priming valves and their associated components is often similar to the operation of the recirculation system used to reprime centrifugal cargo pumps. A typical self-priming deep-well pump is fitted with two or three priming valves that are mounted in the pump's column pipe just above the bowl assembly (Figure 16). When the pump is discharging fluid, these valves are closed. However, when the deep-well pump loses suction, the priming valves open and permit the liquid contained within the pump's column and discharge head to drain into the suction can. As this liquid drains through the open priming valves, a vacuum is created in the discharge head and column pipe. The gas in the bottom of the can, which is displaced by the returning liquid, is drawn by the vacuum through a vent line that is connected from the top of the suction can to the pump's discharge head and into the evacuated portion of the discharge head and column. When the liquid level in the suction tank rises sufficiently for the deep-well pump to regain suction, the flow of liquid through the pump resumes, the priming valves and a check valve in the vent line close, and the gases that have been drawn into the column and discharge head are forced out through a check valve installed at the pump's discharge connection. The priming cycles will continue until enough gas has been removed from the cargo suction line for the deep-well pump to operate normally. As the level in the cargo tank being emptied continues to be reduced, the amount of gas entering the suction can will increase, and the deep-well pump will lose suction more frequently. When the amount of liquid remaining in the cargo tank is not sufficient for the deep-well pump to be reprimed, the pump should be stopped.

**HYDRAULIC-MOTOR-DRIVEN SUBMERSIBLE CARGO PUMPS** Hydraulic-motor-driven submersible pumps are used to discharge cargo on many chemical and multi-petroleum-product carriers. In addition, they are used for cargo discharge on some crude carriers. A separate

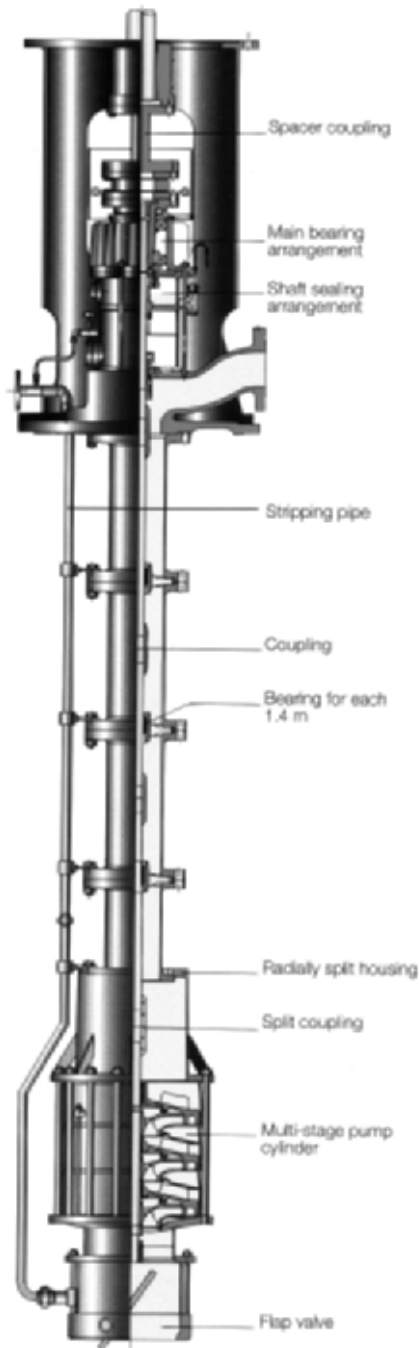


FIGURE 15 Vertical deep-well cargo pump (Svanejoh International A/S)

- 600 Discharge Head
- 604 Adjusting nut
- 608 Head or top shaft
- 616 Stuffing box
- 617 Stuffing-box bushing
- 618 Gland
- 620 Packing
- 624 Bypass pipe
- 641 Top column pipe
- 644 Bottom column pipe
- 646 Line shaft
- 649 Line-shaft coupling
- 652 Bearing retainer or bracket
- 653 Line-shaft bearing
- 655 Impeller-shaft coupling
- 660 Pump or impeller shaft
- 666 Top bowl
- 670 Intermediate bowl
- 672 Bowl bearing
- 673 Impeller
- 674 First-stage (priming-stage) impeller
- 677 Impeller taper lock
- 685 Adapter case
- 689 Suction bell
- 690 Suction-bell bearing
- 702 Autoprime (self-priming) valve housing
- 704 Autoprime (self-priming) valve spring
- 705 Autoprime (self-priming) valve
- 706 Air-release (vent) check valve
- 707 Air-release (vent) line
- 708 First-stage (priming-stage) impeller
- 762 Column-flange bolt
- 764 Bowl cap screw
- 779 Stuffing-box gasket

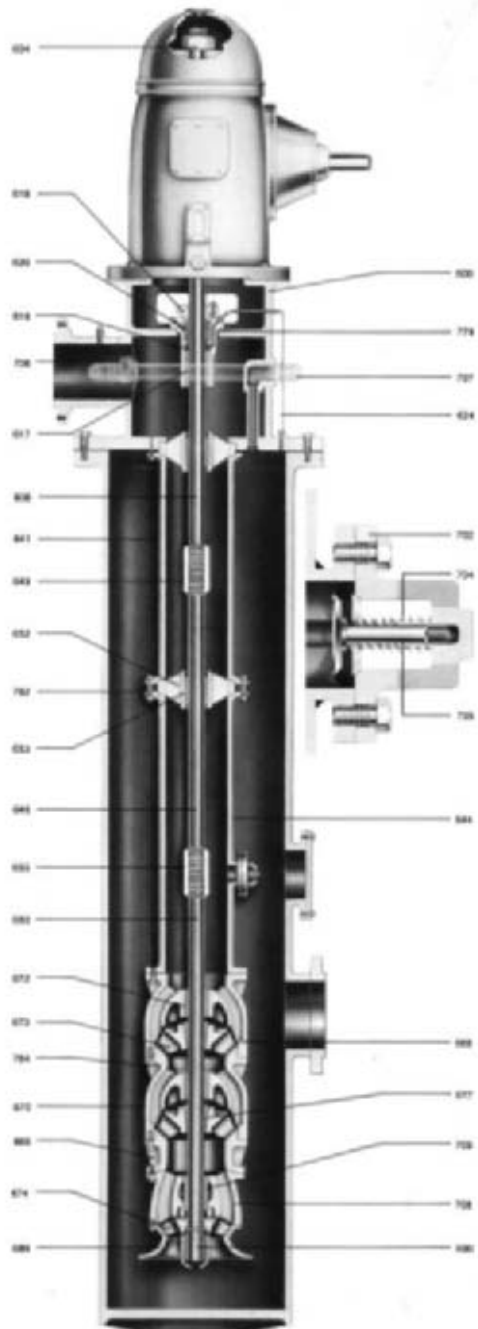


FIGURE 16 Self-priming vertical deep-well cargo pump (ITT/Gould Pumps, Inc.)

pump is usually installed in each cargo tank, which eliminates the need for suction piping. In addition, to prevent different cargoes carried by a vessel from mixing, each pump may be connected to an independent above-deck discharge line. Although the pressurized oil required to drive the hydraulic motors for all of the cargo pumps on a vessel is frequently supplied by a central hydraulic system, a self-contained hydraulic power pack is furnished for each cargo pump on some vessels.

Each submersible unit usually consists of a single-stage end-suction centrifugal pump with a short shaft that is driven, often through either a splined connection or a coupling, by a hydraulic motor (Figure 17). The pump's shaft is typically supported by antifriction ball or roller bearings that are submerged in and lubricated by the hydraulic oil that drains from the motor. The pump is mounted on the lower end of a vertical support pipe that is suspended from a top plate installed on the vessel's main deck. The hydraulic-oil supply and return lines are ordinarily enclosed within this support pipe. Fluid discharged from the pump's volute-type casing typically passes through a second vertical pipe that terminates at an above-deck discharge connection. A control valve that can be used to vary the flow of hydraulic oil to the motor and, therefore, the pump's operating speed valve is usually mounted on the above-deck top plate.

Mechanical or lip-type seals are generally used at the shaft penetrations in a submersible pump-and-hydraulic-motor assembly to prevent hydraulic oil from leaking into a cargo tank and to prevent cargo from mixing with hydraulic oil. Air or inert gas can usually be circulated through a void space or cofferdam that runs through the vertical support pipe that surrounds the hydraulic supply and return lines, the housing that surrounds the hydraulic motor, and a chamber between the pump's seals. After leaving the cofferdam, this gas frequently passes through an above-deck trap in which liquid is separated so a hydraulic-oil or cargo-seal leak can be detected. Compressed air or inert gas is also frequently injected into a submersible pump's above-deck discharge connection after a pump-out has been completed to force cargo contained within the vertical discharge pipe out through a small bypass line connected to the base of the pump. However, because a submersible pump's inlet is generally not fitted with a nonreturn valve, this operation must be performed before the driver is stopped.

It is often possible to disassemble a submersible pump and remove it from a cargo tank for maintenance without disturbing the vertical support pipe or top plate. In most cases, vessels fitted with hydraulic-motor-driven submersible cargo pumps carry one or more portable hydraulically driven submersible pumps that can be lowered into a cargo tank with a winch and used to discharge cargo if the main pump in the tank is inoperable.

In addition to being used for cargo discharge, a submersible cargo pump is sometimes operated while a vessel is underway to circulate cargo through a diffuser so sediment in the liquid does not settle in the cargo tank or through an above-deck heater to prevent the cargo from cooling. Also, to eliminate the need for separate drop lines, on some vessels, liquid is loaded into small cargo tanks by allowing it to flow backwards through a vessel's submersible cargo pumps. When this is done, a nonreverse brake is generally mounted on the submersible pump's shaft to prevent reverse rotation during loading. However, because of the resistance created by the pump's impeller, loading through a submersible cargo pump can increase loading times.

**ELECTRIC-MOTOR-DRIVEN SUBMERSIBLE CARGO PUMPS** Electric-motor-driven submersible pumps are often used to discharge cargo from liquefied natural gas (LNG) and liquefied petroleum gas (LPG) carriers. Each submersible unit typically consists of a vertical centrifugal pump with either one or two impellers that are mounted on the lower end of an electric motor's shaft. In addition, an inducer is often installed at the inlet to the first-stage impeller (the only impeller in a single-stage pump) to reduce the pump's net positive suction head requirements.

Pumps used for cargo unloading are frequently installed directly within a vessel's cargo tanks. Cargo typically enters an electric-motor-driven submersible pump through an opening in the bottom of the pump. After being discharged by the pump's impellers, the cargo often enters an annular passage formed between the motor frame and an outer casing that surrounds the motor. A portion of this liquid usually passes through openings in the motor frame and flows through the motor. In addition to cooling the motor, this bypass

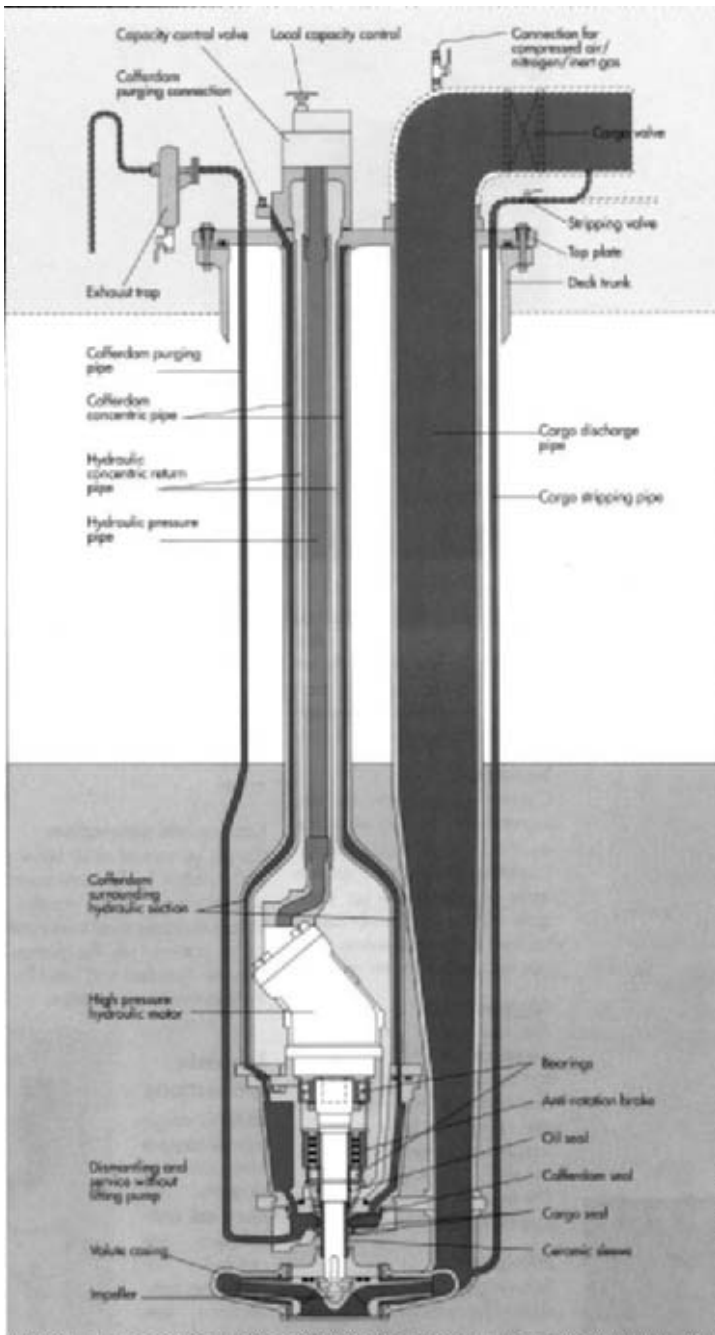


FIGURE 17 Hydraulic-motor-driven submersible cargo pump (Frank Mohn AS)

flow lubricates the ball bearings that support the common pump and motor shaft. After leaving the top of the annular passage, the cargo that has been discharged by the pump passes through a connection located above the motor and enters a vertical pipe that leads to the main deck.

In addition to the main cargo unloading pumps, smaller spray or cool-down pumps are often installed on an LNG carrier. When an LNG carrier is unloaded, some cargo is typically left in each tank. During the voyage back to the loading terminal, the spray pumps circulate this LNG through a cool-down header and spray nozzles in each tank. The LNG vaporizes as it passes through the spray nozzles and absorbs heat from the cargo tanks. This enables the tanks to be kept cold until the vessel is reloaded with additional cargo.

**ROTARY CARGO PUMPS** Some vessels that carry high-viscosity cargoes have multiple-screw- or lobe-type rotary main cargo unloading pumps. In addition, vessels that have centrifugal-type main cargo pumps sometimes also have lower-capacity screw, lobe, or sliding-vane pumps that are used to strip cargo tanks.

A rotary main cargo or stripping pump may be installed in a pump room located in the lower part of a vessel. With this arrangement, the pump can typically take its suction from multiple cargo tanks through interconnected suction piping. So the driver can be isolated from explosive vapor in the pump room, it is frequently installed in an adjacent space and is coupled to the pump with a jackshaft that passes through a bulkhead stuffing box. A typical rotary cargo pump is driven either by a variable-speed driver or by a constant-speed driver through a fluid coupling, which enables the pump speed and, therefore, the capacity delivered to be changed during a pump-out.

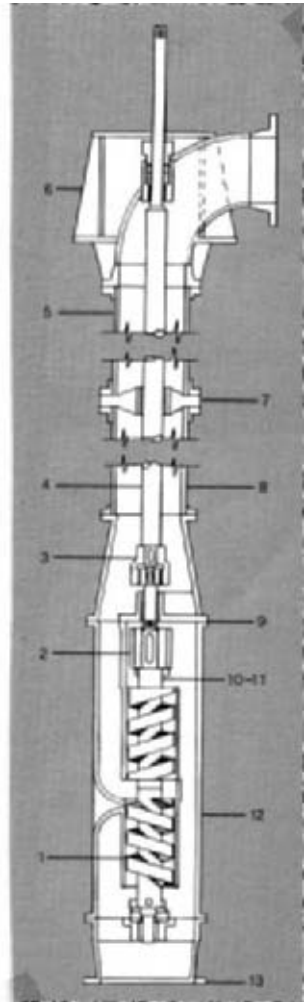
Some multiple-screw rotary cargo pumps are furnished in a deep-well configuration (Figure 18), which can eliminate much of the suction piping in a cargo system. Although a vertical driver can be used to drive a deep-well rotary pump, many deep-well rotary pumps are driven through right-angle gears by horizontal motors or engines to facilitate maintenance and reduce vertical height requirements. Typically, the output shaft of the above-deck vertical driver or right-angle gear is connected to the power rotor in the pump through a line shaft that is enclosed within a vertical column pipe. Cargo discharged by a deep-well rotary pump may pass through the column, or it may pass through a separate vertical pipe mounted adjacent to the column. Bearings that support the line shaft, together with the pump's bearings and timing gears, when used, are sometimes lubricated by the pumped fluid. Alternatively, a deep-well rotary pump may be furnished with a pressurized forced-feed lubrication system.

**RECIPROCATING CARGO PUMPS** Direct-acting reciprocating pumps are used to strip cargo tanks on some vessels. These units typically have double-acting pistons in both the liquid- and the drive-encylinders. Some reciprocating stripping pumps are mounted in a pump room and are connected to the vessel's cargo tanks through suction piping. With this arrangement, one pump can be used to strip multiple tanks. Pumps installed in this fashion are frequently duplex units (that is, two liquid cylinders) that are mounted vertically and are driven by steam (Figure 19).

When used on multi-product carriers, a separate reciprocating stripping pump may be used for each cargo tank. These stripping pumps are frequently driven by compressed air or inert gas. On some vessels, a horizontal duplex reciprocating pump is mounted in the bottom of each cargo tank. Alternatively, a vertical simplex (that is, one liquid cylinder) pump with a liquid cylinder that is submerged within a cargo tank and a drive cylinder that is mounted on deck is sometimes used. With this latter configuration, the liquid-end piston is coupled to the piston in the drive cylinder through a long intermediate shaft.

**INERT-GAS SYSTEM PUMPS** To reduce the risk of explosion and fire, the space in a cargo tank above a flammable liquid must typically be kept filled with an inert gas. Some vessels use flue gas from either a fossil-fueled steam boiler or a dedicated oil-fired inert-gas generator to inert cargo tanks. A pump is usually required to deliver seawater to a scrubber where the water is used to cool, clean, and desulfurize the inert gas. A separate pump is also frequently required to supply seawater to a wet-type deck seal that is used to pre-

- 1 Pumping screws
- 2 Timing gears
- 3 Coupling
- 4 Line shaft or jackshaft
- 5 Column pipe (standpipe)
- 6 Discharge head with carrying plate
- 7 Bearing bracket
- 8 Column pipe (standpipe)
- 9 Bearing housing
- 10 Long pump shaft
- 11 Short pump shaft
- 12 Pump body or housing
- 13 Suction connection / bearing housing



**FIGURE 18** Deep-well screw pump (IMO-Warren Pump)

vent vapor in the vessel's cargo tanks from flowing backwards through the inert-gas supply piping and into the machinery spaces. It is common to use single-stage electric-motor-driven centrifugal pumps for both of these applications.

**TANK-CLEANING PUMPS** On some vessels, hot seawater is used to clean cargo tanks of residue that remains in the tanks after the liquid cargo has been discharged. A typical tank-cleaning or tank-washing pump takes suction from a sea chest and discharges seawater through a heater in which it is often heated to a temperature of approximately 200°F (93°C). The hot seawater then passes through nozzles in tank washing machines and is sprayed onto the sides of the cargo tanks being cleaned. Single- and two-stage centrifugal pumps that are driven by steam turbines, electric motors, or hydraulic motors are frequently used in this application. A tank-washing pump may also be used for other purposes, such as fire fighting.

- |   |                       |   |                                  |
|---|-----------------------|---|----------------------------------|
| 1 | Steam cylinder        | 6 | Liquid piston                    |
| 2 | Steam piston rod      | 7 | Liquid piston packing            |
| 3 | Liquid cylinder       | 8 | Liquid valve service             |
| 4 | Liquid-cylinder liner | 9 | Air chamber (pulsation dampener) |
| 5 | Liquid piston rod     |   |                                  |

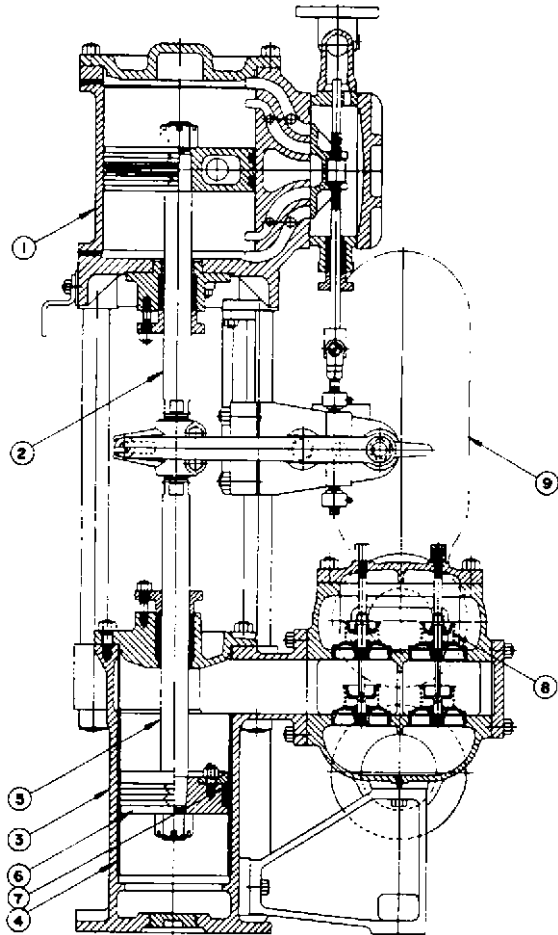


FIGURE 19 Duplex direct-acting reciprocating pump (Flowservice Corporation)

As an alternative to washing cargo tanks with seawater, crude carriers frequently clean tanks with crude oil, referred to as crude-oil washing (COW). A general-service pump is often used on a crude carrier to deliver pressurized crude oil to the vessel's tank-washing machines. The pump may receive this oil from a holding or slop tank on the vessel. The general service pump may also be used to deliver cargo to an eductor that strips cargo tanks during the final stages of unloading or during crude-oil washing. This cargo, which serves as the motive fluid in the eductor, mixes with the fluid being removed from the cargo tank and is then usually discharged by the eductor into one of the vessel's slop tanks. On a typical crude carrier, the general-service pump is similar in configuration to the vessel's main cargo pumps but is smaller.



**FURTHER READING**

---

- Cowley, J., ed. *The Running and Maintenance of Marine Machinery*. 6th ed., Marine Management (Holdings) Ltd., London, 1992.
- Feck, A. W., and Sommerhalder, J. O. "Cargo Pumping in Modern Tankers and Bulk Carriers." *Marine Technology*. Vol. 4, No. 3, 1967.
- Harrington, R. L., ed. *Marine Engineering*. The Society of Naval Architects and Marine Engineers, Jersey City, NJ, 1992.
- Hunt, E. C., ed. *Modern Marine Engineer's Manual*. Vol. I, 3rd ed., Cornell Maritime Press, Centreville, MD, 1999.
- McGeorge, H. D. *Marine Auxiliary Machinery*. 7th ed., Butterworth-Heinemann Ltd., 1995.
- Paashaus, R. F. "An Analysis of Cavitation Damage in Commercial Marine Condensate Pumps." SNAME/ASME meeting, New York, December 1964.
- Sembler, W. J. "The Design and Operation of Pumps Furnished for Marine Cargo Service." *Marine Technology*. Vol. 25, No. 1, 1988, pp. 1-29 and No. 2, 1988, pp. 75-104.
- Specification for Centrifugal Pump, Shipboard Use*. ASTM F 998-86 (1993), American Society for Testing and Materials, West Conshohocken, PA, 1993.
- Specification for Rotary Positive Displacement Pumps, Commercial Ships Use*. ASTM F 1510-94, American Society for Testing and Materials, West Conshohocken, PA, 1994.
- Standard Specification for Mechanical Seals for Shipboard Pump Applications*, ASTM F 1511-95. American Society for Testing and Materials, West Conshohocken, PA, 1995.

---

# SECTION 9.12

---

# REFRIGERATION, HEATING, AND AIR CONDITIONING

---

MELVIN A. RAMSEY

---

## **HEATING**

---

Heat is usually generated at a central point and transferred to one or more points of use. The transfer may be by means of a liquid (usually water), which has its temperature increased at the source and gives up its heat at the point of use by reduction of its temperature. It may also be transferred by means of a vapor (usually steam), which changes from a liquid to a vapor at the source and gives up its heat at the point of use by condensation. Pumps may be required in both of these methods.

---

## **HOT WATER CIRCULATING**

---

A centrifugal pump best meets the requirements of this service. Water is usually used in a closed circuit so that there is no static head. The only resistance to flow is that from friction in the piping and fittings, the heater, the heating coils or radiators, and the control valves. In selecting the pump, the total flow resistance at the required flow rate should be calculated as accurately as possible, with some thought as to how much variation there might be as a result of inaccuracy of calculations or changes in the circuit because of installation conditions. It is not good practice to select a pump for a head or capacity considerably higher than that required, as this is likely to result in a higher noise level as well as increased power.

When hot water is used for radiation in a single circuit, through several radiators, the water temperature variation is usually only about 20 F° (11 C°) at the time of maximum requirements, so there is not too great a difference in heat output between the first and last radiator in the circuit. With the flow rate based on water at 180° to 200°F (82 to 93°C) to heat air to about 75°F (24°C), a 10% reduction in the flow would have little effect, as the

actual difference would increase to only 22 F° (12°C), and the reduction in the heat output of the radiator with 178°F (81°C) water would be only about 2%. Reference to Section 8.1, on the selection of pumps and the prediction of performance from the head-capacity pump curves and system head-flow rate curves, will show that a rather large undercalculation of circuit head loss would be necessary to produce a flow rate 10% less than desired.

Greater temperature differences are frequently used for other radiation circuits, and a reduced flow rate may have a greater temperature differential than in the single circuit. Whatever the condition, the pump should be selected only after full consideration of all the factors, and not by use of so-called safety factors, which are likely instead to be “trouble factors.”

**Air in the Circuit** Initially, the entire circuit will be full of air that must be displaced by the water. Arrangements should be provided to vent most of the air before the pump is operated. Even if all the air is eliminated at the start, more will be separated from the water when it is heated. Any water added later to replace that lost to reevaporation will result in additional trapped air when the water is heated. Means must be provided for continuous air separation, but this cannot be accomplished by vents at high points in the piping because the flow is usually turbulent and the air is not separated at the top of the pipe.

A separator installed before the pump intake will remove the air circulating in the system. In a heating system, an air separation device is often provided at the point where the water leaves the boiler or other heating source. If the pump intake is immediately after this point, this is the point of lowest pressure and highest temperature in the system, and therefore it is the point where separation of air from the water can be most effectively achieved.<sup>1</sup>

If there are places in the system where the flow is not turbulent, air may accumulate and remain at these points and interfere with heat transfer. Automatic air vents should seldom or never be used. If they are used, it is important that they be located only where the pressure of the water is always above that of the surrounding air, whether the pump is operating or idle. Otherwise, the air vent becomes an air intake.

Several important factors influence the choice of a pump for a hot water system with a number of separate heating coils, each having a separate control. Many systems in the past used three-way valves to change the flow from the coil to the bypass. When two-way valves are used, low-flow operation may occur for a large portion of the operating time. For this type of operation, therefore, the pump selected should have a flat performance curve so the head rise is limited at reduced flows. A very high head rise can cause problems when many of the valves are closed. Excessive flow rates through the coils and greater pressure differences across the control valves are some of the problems that can be avoided with a flat pump curve. A centrifugal pump should not operate very long with zero flow, for it would overheat. This condition is controlled by using one or two three-way valves, a relief bypass, or a continuous small bleed between the supply and the return line. Whichever means is used to control minimum flow, the circuit must be able to dispose of the heat corresponding to the pump power at that operating condition, without reaching a temperature detrimental to the pump.

**Types of Pumps** Many pumps for hot water circulation are for flow rates and heads in the range of in-line centrifugal pumps that are supported by the pipeline in which they are installed. Such pumps are available up to at least 5 hp (3.73 kW) and operate with good efficiency. More important than the type of pump are the performance and efficiency.

For greater flow rates and heads (and even for the smaller ones), the standard end-suction pump can be used. In the intermediate range, the use of an in-line or end-suction pump is a question not of one being better than the other but whether one or the other is better suited to the overall design and arrangement. Practically all the in-line or end-suction pumps for this service use seals instead of packing.

If the hot water system is of the medium- or high-temperature type, above 250°F (121°C), the pump must be carefully selected for the pressure and temperature at which it will operate.

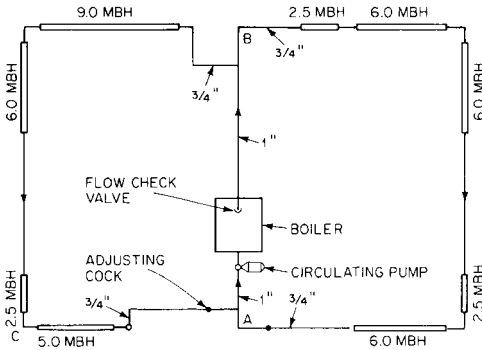


FIGURE 1 A series loop system

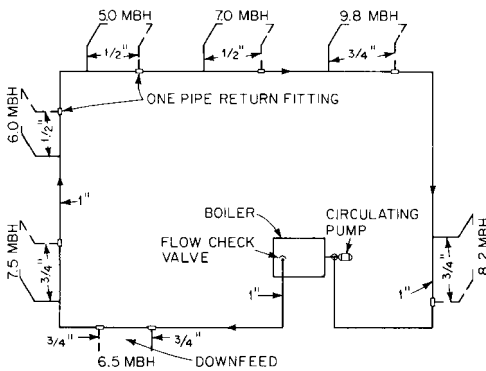


FIGURE 2 A one-pipe system

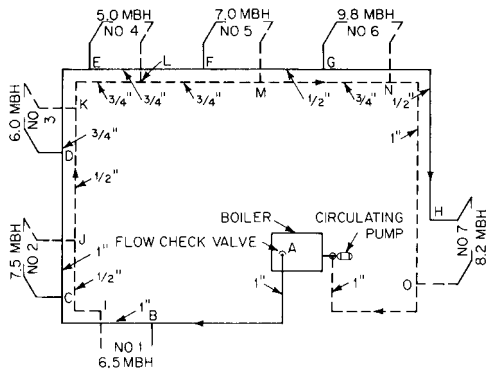
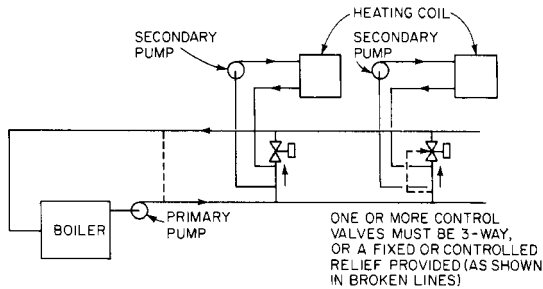


FIGURE 3 A two-pipe reverse-return system. A circuit with primary-secondary pumping provides variable temperature at constant flow rate for two or more coils.

**Types of Water Circuit** There are several types of water circuits. Those shown in Figures 1 and 2 are suitable for smaller systems and can be used for larger systems by having several of these circuits in parallel. The one shown in Figure 3 is suitable for small or



**FIGURE 4** A circuit with primary-secondary pumping to provide variable temperature at constant flow rate for two or more coils

very large circuits, but the reverse return would add considerably to the cost if the circuit extended in one direction instead of in a practically closed loop as shown. For the extended circuit, a simple two-pipe circuit, with proper design for balancing, would be used.

There are a number of reasons for using other circuits, particularly primary-secondary pumping where the system is more extended or complicated, such as continuous circulation branches with controlled temperature. When a coil heats air, part or all of which may be below freezing, the velocity of the water in the tubes and its temperature at any point in the coil must be such that the temperature of the inside surface of the tube is not below freezing. The circuit shown in Figure 4 makes this possible.

Primary-secondary pumping permits flow rates and temperatures in branch circuits to be different from those in the main circuit without the flow and pressure differences in the mains or branches having a significant effect on each other. There are many possible primary-secondary circuits to meet different requirements.

**Steam Heating Systems** No pumping is required with the smallest and simplest steam systems if there is sufficient level difference between the boiler and condensers (radiators, heating coils, and so on) to provide the required flow. When insufficient head exists between the level of the condensate in the condenser and the boiler to produce the required flow to the boiler, a pump must be introduced to provide the required head. Because the condensate in the hot well will be at or near its saturation temperature and pressure, the only *NPSH* available to the pump will be the submergence less the losses in the piping between the hot well and the pump. A pump must be selected that will operate on these low values of *NPSH* without destructive cavitation.

In many cases, particularly for very large systems, vacuum pumps are used to remove both the condensate and air from the condensers. This permits smaller piping for the return of condensate and air, more positive removal of condensate from condensers, and, when high vacuums—above 20 in (0.5 m)—are possible, some control of the temperature at which the steam condenses. The use of vacuum return, particularly with higher vacuums, helps reduce the possibility of frozen heating coils exposed to outside air or to stratified outside and recirculated air. Vacuum return pumps are available for handling air and water. Vacuum, condensate, and boiler-feed pumps with condensate tanks are all available in package form.

Most condensate pumps are centrifugal. Vacuum pumps may be rotary, including a rotary type with a water seal and displacement arrangement.

**Fuel Oil** When oil burners are fairly far from the oil storage tank or when there are a number of burners at different locations in a building, a fuel oil circulating system is required. The flow rate is relatively low—1 gpm (3.8 liters/min) would provide more than 8,000,000 Btu/h (560,000 Gcal/s or 2,343,000 W)—and a small gear pump is usually used.

## AIR CONDITIONING

---

Many air conditioning systems produce chilled water at a central location and distribute it to air cooling coils in various locations throughout the building or group of buildings. Centrifugal pumps are particularly well suited for this service.

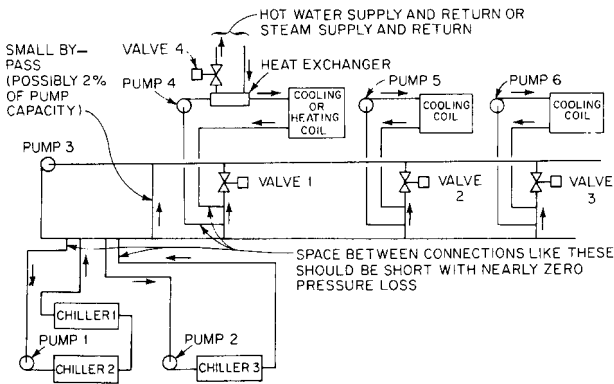
The type of circuit and the number of pumps used require an evaluation of several factors:

1. The cooling requirements usually vary over a wide range.
2. Flow rate through a chiller must be kept above the low point where freezing would be possible and below the point where tube damage would result. Some methods of chiller capacity control require a constant flow rate through the chiller.
3. The temperature of the surface cooling the air must be low enough to control the relative humidity.<sup>3</sup> This limits the use of parallel circuits through chillers when one circuit may not be in operation and permits unchilled water to mix with water in the operating chiller. Under these conditions, it is difficult or impossible to attain a sufficiently low mixture temperature and the control of flow rate and water temperature in the air cooling coils is limited.<sup>4</sup>
4. Below-freezing air may sometimes pass over all or part of a coil. This condition would require a flow rate and water temperature adequate to keep the temperature of all water-side surfaces of tubes above freezing. Many water circuits are available to achieve the desired results. For control of the relative humidity, the air flow circuit must also be considered. Figure 5 shows a circuit for cooling coils with a variable air flow rate at constant air-leaving temperature and with two chillers in series. In addition, the two chillers are shown in parallel with a third chiller. This arrangement permits continuous flow through the coils to reduce the possibility of freezing when the average temperature of the air entering the coil is above freezing, but the usual stratification results in a below-freezing temperature for some of the air entering the coil. The word *reduce* is used because full prevention requires appropriate air flow patterns, water velocities, and temperatures to assure that the water side of the surface will not be below freezing at any point in the coil. One of the coils is also arranged to add heat whenever the temperature of the air leaving the coil must be above that of the average air-entering temperature. Some circuits attempt to obtain the desired results from the circuit in Figure 5 with fewer pumps. However, the use of fewer pumps, although it would reduce the cost slightly, would also require three-way instead of two-way valves, would make control somewhat more complicated, and would almost certainly result in greater power consumption. The circuit shown permits pump heads to match the requirements exactly. It also permits stopping an individual pump when flow is not required in one of the circuits; two-way valves 1, 2, and 3 will reduce pump circulation and the power of pump 3 at partial cooling load.

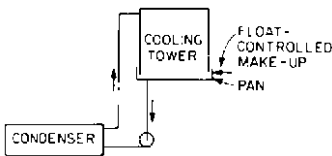
**Air Separation and Removal** The methods for handling air with chilled water are about the same as those for hot water except that there is not usually a rise in temperature above that of the make-up water to produce additional separation of air. An expansion tank is required, but the reduced temperature difference requires a much smaller tank than with hot water.

**Condenser Water Circulation** Condenser water may be recirculated and cooled by passing through a cooling tower, or it may be pumped from a source such as a lake, ocean, or well.

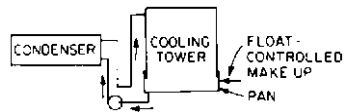
**Cooling Tower Water** Centrifugal pumps are used for circulating cooling tower water. The circuit, which is open at the tower where the water falls or is sprayed through the air, transfers heat to the air before the water falls to the pan at the base of the tower. A pump then circulates the water through the condenser, as shown in Figure 6. In this case, the pump must operate against a head equal to the resistance of the condenser and piping plus the static head required to the tower from the water level in the pan.



**FIGURE 5** Pump 3 does not operate unless pump 1 or pump 2 operates. Pump 1 operates only if chiller 1 or chiller 2 is required and operating. Pump 2 operates only if chiller 3 is required and operating. Pump 4 operates when air circulates over the coil to which the pump is connected, if cooling or heating is required, or if any air enters this coil below about 35°F (12°C). Pumps 5 and 6 operate in the same manner for the coils to which they are connected. Operation of pumps 4, 5, and 6 helps to equalize the temperature of air streams that enter the coils at different temperatures, and thus it may be desirable to operate these pumps continuously when air circulates over the coils. Valves 1 and 4 are interlocked, and so one must be closed before the other can open. Also, valve 1 should be prevented from opening if the temperature of the water in the pump 4 circuit is above about 90°F (32°C).



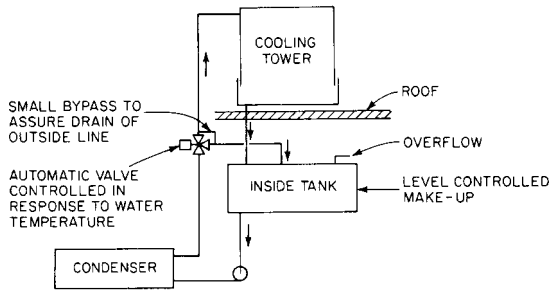
**FIGURE 6** Cooling tower with condenser below pan water level



**FIGURE 7** Cooling tower with condenser above pan water level

Figure 7 shows a somewhat similar circuit except that here the condenser level is above the pan water level. The size of the pan of a standard cooling tower is sufficient to hold the water in the tower distribution system so the pan will not overflow and waste water each time the pump is shut down. This capacity also assures that the pan will have enough water to provide the amount required above the pan level immediately after start-up, without waiting for the make-up that would be needed if there was any overflow when the pump stopped. When the condenser or much of the piping is above the pan level, the amount draining when the pump is stopped will exceed the pan capacity unless means are provided to keep the condenser and lines from draining. In Figure 7, it will be noted that the line from the condenser drops below the pan level before rising at the tower. This keeps the condenser from draining by making it impossible for air to enter the system. This is effective for levels of a few feet, but useless if the level difference approaches the barometric value. Such large level differences should be avoided if possible because they require special arrangements and controls.

When a cooling tower is to be used at low outside temperatures, it is necessary to avoid the circulation of any water outside unless the water temperature is well above freezing. The arrangement shown in Figure 8 provides this protection. The inside tank must now provide the volume previously supplied by the pan, in addition to the volume of the piping from the tower to the level of the inside tank. Condensers or piping above the new overflow level must be treated as already described and illustrated in Figure 7, or additional tank volume must be provided.



**FIGURE 8** Cooling tower with inside tank to permit operation when outside wet-bulb temperatures are below freezing

The only portion of the inside tank that will be available for the water that drains down after the pump stops is that above the operating level. This level is fixed by the height of liquid required to avoid cavitation at the inlet to the pump. The suction piping to the pump must remove only water from the tank without air entrainment.<sup>5</sup> The size of this pipe at the tank outlet should be determined not by pressure loss but by the velocity that can be attained from the available head. Exact data on this are not available, but the required velocity at the *vena contracta* (about 0.6 of the pipe cross-sectional area) can be calculated from  $V = (2gh)^{1/2}$  where  $h$  is the height of the operating level above the *vena contracta*. The outlet from the tank should be at least as large as that from the cooling tower.

**Well, Lake, or Sea water** Centrifugal pumps are used for all of these services. The level from which the water is pumped is a critical factor. The level of the water in a well will be considerably lower during pumping than when the pump does not operate. When pumping is from a lake or from the ocean, the drawdown is usually not significant. When pumping is from a pit where the water flows by gravity, there will be a drawdown that will depend on the rate of pumping. With a sea water supply, there will be tidal variations. A lake supply may have seasonal level differences.

All these factors must be taken into consideration in selecting the level for mounting the pump to assure that it will be filled with water during start-up. Check or foot valves may be used for this purpose. Also, the head of the water entering the pump at the time of highest flow rates must not be so low that the required *NPSH* is not available.

To assure proper pump operating conditions, the pump is frequently mounted below the lowest level expected during zero flow conditions, as well as below the lowest level expected at the greatest flow rate. These conditions may require a vertical turbine pump. The motor should be above the highest water level with a vertical shaft between the motor and the pump bowls, or the motor can be of the submerged type and connected directly to the pump bowls.

**Refrigeration** For refrigeration systems with temperatures near or below freezing, pumps are often required for brine or refrigerant circulation. The transfer of lubrication oil also frequently requires pumps.

**Brine Circulation** The word *brine*, as used in refrigeration, applies to any liquid that does not freeze at the temperatures at which it will be used and which transfers heat solely by a change in its temperature without a change in its physical state. As far as pumping is concerned, brine systems are very similar to systems for circulating chilled water or any liquid in a closed circuit. A centrifugal pump is the preferred choice for this service, but it must be constructed of materials suitable for the temperatures encountered. For some brines, the pump materials must be compatible with other metals in the system to avoid damage from galvanic corrosion.

Tightness is usually more important in a brine circulating system than in a chilled water system. This is true not only because of the higher cost of the brine but also because



of problems caused by the entrance of minute amounts of moisture into the brine at very low temperatures.

**Refrigerant Circulation** For a number of reasons—including pressure and level considerations as well as improvement of heat transfer—the refrigerant liquid is often circulated with a pump. The centrifugal pump is usually preferred for this purpose.

The liquid being pumped as a refrigerant may be the same one that is pumped as a brine. Whereas the material is all in liquid form throughout the brine circuit, some portion of it is in vapor form during its circulation as a refrigerant. In a refrigerant circulating system, most of the heat transfer is by evaporation, condensation, or both.

As there are changes from liquid to vapor, the liquid to be pumped must be saturated in some portion or portions of the circuit. Sufficient *NPSH* for the pump must be provided by the level of saturated liquid maintained in the tank where the liquid is collected. The level difference required for the *NPSH* must provide adequate margin to compensate for any temperature rise between the tank and the pump. This is an important consideration because the liquid temperature will usually be considerably lower than that of the air surrounding the pump intake pipe.<sup>5</sup>

When the pump is not operating, it may be warm and may contain much refrigerant in vapor form. It is usually necessary to provide a valved bypass from the pump discharge back to the tank so gravity circulation can cool the pump and establish the prime.

Pumps for this service may require a double seal, with the space between the seals containing circulated refrigerant oil at an appropriate pressure. This will reduce the possibility of the loss of relatively expensive refrigerant and eliminate the entrance of any air or water vapor at pressures below atmospheric. A hermetic motor may also be used for this service and thus avoid the use of seals.

**Lubricating Oil Transfer** Because the flow rates for lubricating oil transfer are rather low, the gear pump is usually preferred. The *NPSH* requirement is also critical here because, although the oil itself is well below the saturation temperature at the existing pressure, it contains liquid refrigerant in equilibrium with the refrigerant gas. Any temperature rise or pressure reduction will result in the separation of refrigerant vapor. It is important, therefore, to design the path for oil flow from the level in the tank where it is saturated with the same safeguards necessary for refrigerant pumping.

To reduce the oil pumping problem, the oil can be heated to a temperature above that of the ambient air and vented to a low pressure in the refrigerant circuit. This eliminates temperature rise in the pump as well as in the suction, with the corresponding reduction of available *NPSH*.

Usually, the oil flow is intermittent, and the best results are obtained by continuous pump operation discharging to a three-way solenoid valve. This discharge would be bypassed back to the tank whenever transfer from the tank is not required. This assures even temperature conditions and a pump free of vapor.

## REFERENCES

---

1. *Tested Solutions to Design Problems in Air Conditioning and Refrigeration*, Industrial Press, New York, Section 3.
2. *Tested Solutions to Design Problems in Air Conditioning and Refrigeration*, Industrial Press, New York, Section 10.
3. *Tested Solutions to Design Problems in Air Conditioning and Refrigeration*, Industrial Press, New York, Section 1, pp. 19–38; Section 4, pp. 63–65.
4. *Tested Solutions to Design Problems in Air Conditioning and Refrigeration*, Industrial Press, New York, Section 9, pp. 119–125.
5. *Tested Solutions to Design Problems in Air Conditioning and Refrigeration*, Industrial Press, New York, Section 2, pp. 44–47.

---

# SECTION 9.13

---

# PUMPED STORAGE

---

GEORGE R. RICH  
HOWARD A. MAYO, JR.

## **SIZE OF INSTALLATION**

---

In the typical steam-based utility, it is the function of pumped storage to (1) furnish peaking capacity on the weekly load curve (Figure 1) and (2) generate full pumped storage in an emergency for from 10 to 15 h, as required by the particular system. On the basis of comparative cost estimates, the most economical size of installation is selected.

The principal features of a typical pumped storage project are shown schematically in Figure 2. The overall efficiency is about 2:3; that is, 3 kW of pumping power will yield 2 kW of peak generation. The economy of the process stems from the fact that dump energy for pumping is worth about 3 mills/kW · h, whereas peak energy is worth about 7 milli/kW · h. There is also an operating advantage. Because of the ease and rapidity with which it may be placed on-line and because of its low maintenance charges, pumped storage is ideally suited to peaking operation. On the other hand, for maximum economy, modern high-pressure, high-temperature thermal plants should operate continuously near full load on the base portion of the load curve.

Table 1 shows a typical calculation to determine the reservoir capacity needed for sustaining the weekly load curve. The reservoir capacity to carry full load for a 10- to 15-h emergency is obtained simply by equating the electrical energy in kilowatt-hours in the load to the potential hydraulic energy stored in the upper reservoir.

## **SELECTION OF UNITS**

---

At this stage of the basic engineering, it is necessary to make (in collaboration with the equipment manufacturers) at least a tentative selection of capacity, diameter, speed, and submergence for the turbomachine. This will be required for refinement of the calculations

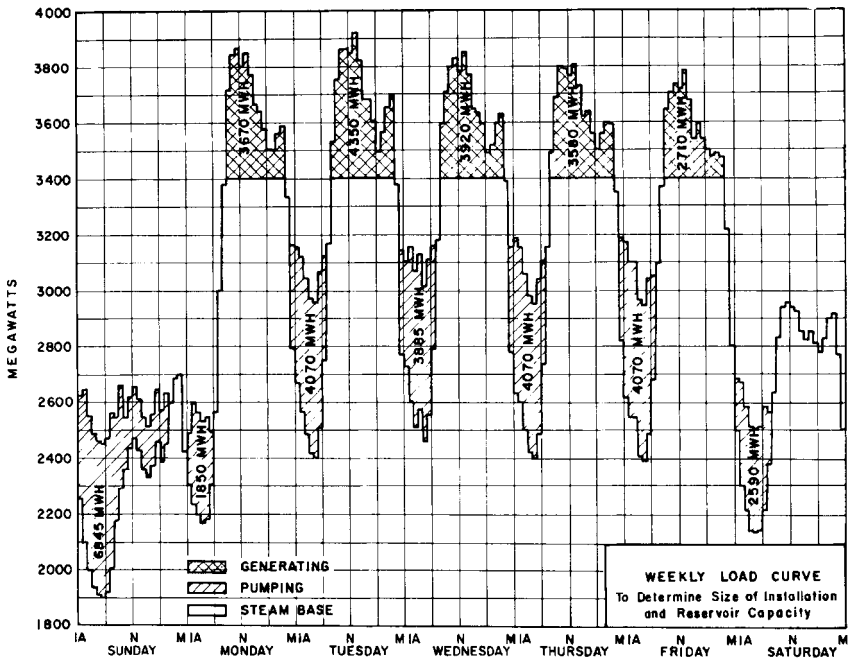


FIGURE 1 Weekly load curve

illustrated in Table 1 and also for the calculation of hydraulic transients that follows. In the head range most attractive for overall project economy, 500 to 1500 ft (152 to 457 m), manufacturers are prepared to offer a single turbomachine that is capable of operating as a pump and whose direction of rotation is opposite that of a turbine. Electrical manufacturers offer a similar machine capable of operating as a synchronous motor for pumping and, in the opposite direction of rotation, as a generator. These machines are designated *pump turbines* and *generator motors*.

For best economy, the speed of the unit should be as high as is practicable without involving an objectionable degree of cavitation of the impeller under the assumed submergence below minimum tailwater. This speed is established (1) by model tests for cavitation at the hydraulic laboratories of the manufacturers and (2) by evaluating experience with similar prototype installations.

Figure 3 is an experience chart showing specific speed  $N_s = \text{rpm} \cdot \text{hp}^{1/2}/H^{5/4}$  versus head for the machine acting as a turbine, where  $H$  is total head, and Figure 4 shows the specific speed  $N_s = \text{rpm} Q^{1/2}/H^{3/4}$  for the machine acting as a pump. These charts presuppose moderate values of submergence because unusually deep settings are uneconomical from the structural standpoint. Three curves are fitted to the installations shown, the equation of the curves being  $N_s = K/H^{1/2}$ . The depth of submergence may be verified by checking against the value of the cavitation constant  $\sigma = (H_a - H_{vp} - H_s)/H$  given by the manufacturer's cavitation model test curves. Here  $H$  = total head,  $H_{vp}$  = vapor pressure,  $\sigma$  and  $H_a$  = atmospheric head. A typical curve of the family is shown in Figure 5.

When the unit has been selected, manufacturers will furnish (in advance of bid invitations) prototype performance curves similar to Figures 6, 7, 8a, and 8b. Figures 8a and 8b are designated four-quadrant synoptic charts and are required for the calculation of hydraulic transients. Figure 8b is for a 5.59-in (142-mm) gate opening. This is the largest gate opening at which the unit will be operating in the pumping cycle. Figure 8a, for an

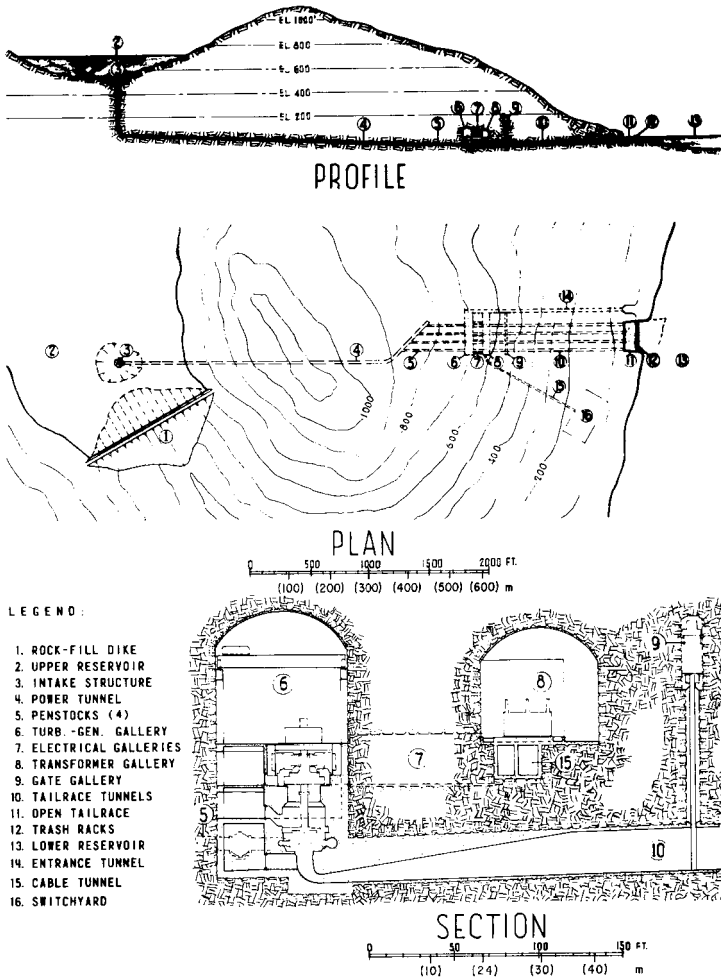


FIGURE 2 Schematic arrangement for a pumped storage project. Elevations are in feet (1 ft = 0.3048 m).

8.94-in (227-mm) gate opening, is for operation on the turbine cycle only. Figure 9 shows a schematic view of a pump-turbine with motor generator and starting motor.

### HYDRAULIC TRANSIENTS

In preparing purchase specifications for the generator motor, it is necessary to establish the maximum transient speed and the moment of inertia of the rotor,  $WR^2$  ( $GD^2$ ). Similarly, for the pump turbine and penstock, it is necessary to determine the maximum water-hammer. This primary calculation, as summarized in Figure 10 and Table 2, is made by the trial-and-error method of arithmetic integration, using various trial values of  $WR^2$  for the condition of full-load rejection on all units during the generating mode with the turbine gates assumed "stuck" in the full-gate position.

**TABLE 1** Determination of reservoir capacity

		(1) Generating, MW	(2) Pumping, MW · h	(3) Equivalent generation (col. 2 × $\frac{2}{3}$ ), MW · h	(4) Net daily change in reservoir, MW · h	(5) Cumulative change in reservoir, MW · h	Remarks
Monday	PM	3670			-3670	-3670	
Tuesday	AM		4070	2710			
	PM	4350			-1640	-5310	
Wednesday	AM		3885	2585			
	PM	3920			-1335	-6645	
Thursday	AM		4070	2710			
	PM	3580			-870	-7515	Reservoir empty
Friday	AM		4070	2710			
	PM	2710			0	-7515	
Saturday			2590	1725	+1725	-5790	
Sunday			6845	4560	+4560	-1230	
Monday	AM		1850	1230	+1230	0	Reservoir full

Required reservoir capacity to sustain weekly load curve:

$$\frac{7515 \times 1000 \times 550 \times 3600}{62.4 \times 43,560 \times 0.746 \times 900 \times 0.85} = 9600 \text{ acre} \cdot \text{ft}$$

Hours of capacity at full load and 900 ft (274 m) head:

$$\frac{9600 \times 62.4 \times 43,560 \times 0.746 \times 900 \times 0.85}{525 \times 1000 \times 550 \times 3600} = \pm 14.3 \text{ h}$$

#### Pertinent Data

Generating = rated net head = 900 ft (274 m)

Generating capacity at rated head for 3 units = 525 MW

Pumping = rated net head = 930 ft (283 m)

Pumping power at rated head for 3 units = 555 MW

Pumping-to-generating ratio = 3 to 2

Upon instantaneous loss of load, the unit builds up overspeed. The increase in speed above normal causes a reduction in turbine discharge, which causes waterhammer, which in turn further increases the power delivered to the rotor. This pyramiding continues until the arrival of negative reflected water hammer from the upper reservoir. The head then decreases. The unit is then so much over speed that it begins to act as a brake, as shown by the four-quadrant synoptic chart (Figure 8). As shown by Figure 10 and Table 2, the process gradually damps down to the steady-state runaway speed and head. Many additional and more refined calculations are made later in the course of the design to establish the optimum governor time and rate of turbine gate closure, as given in detail in the works listed at the end of this section.

## STARTING THE UNIT

The procedure for starting the unit is an essential feature of the design. There are three cases to be considered: (1) the pumping mode, (2) the conventional generating mode, and (3) rotating spinning reserve in the generating mode.

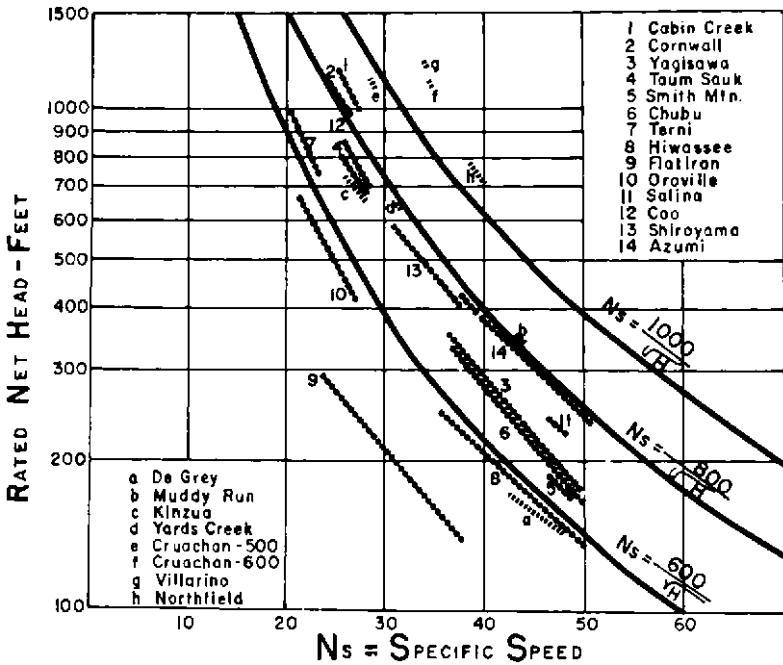


FIGURE 3 Rated net head versus specific speed for a turbine (1 ft = 0.3048 m;  $N_s = 0.2622(\text{kW})^{1/2}/H^{3/4}$ ). See Subsection 6.1.4 for the relation of  $N_s$  to the universal specific speed  $\Omega_s$ .

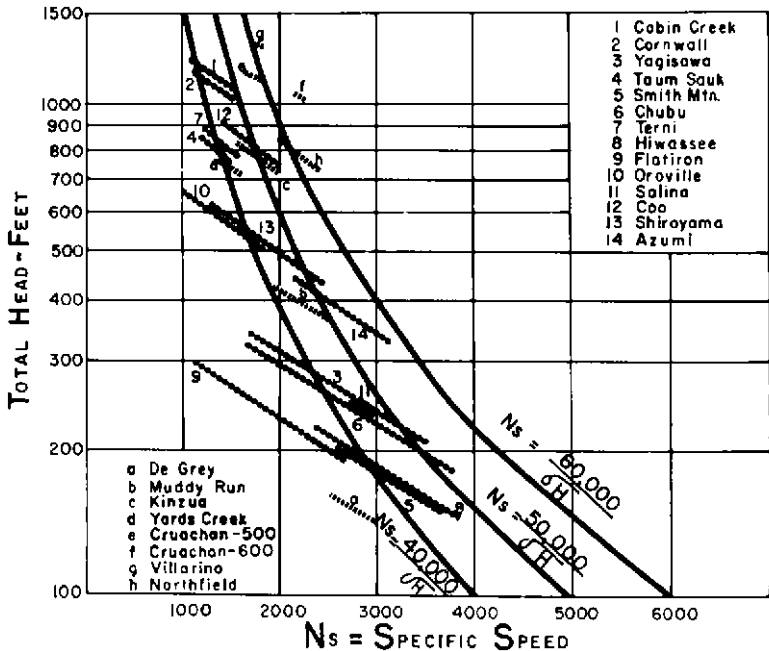


FIGURE 4 Total head versus specific speed for a pump (1 ft = 0.3048 m;  $N_s = 51.65(\text{rpm}) \sqrt{\text{m}^3/\text{s}}/H^{3/4} = 2733 \times \Omega_s$ , where the universal specific speed  $\Omega_s$  is defined in Chapter 1 and Section 2.1).

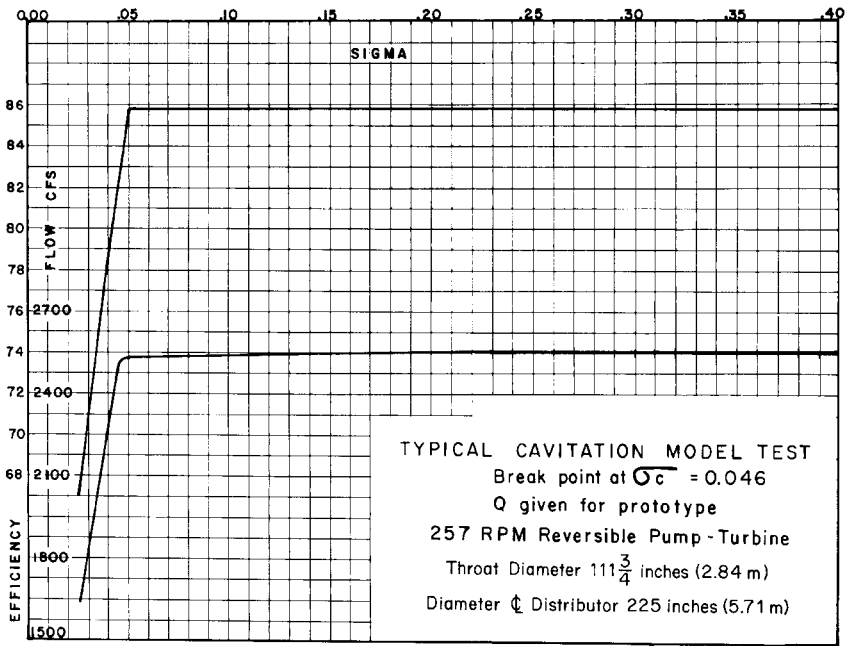


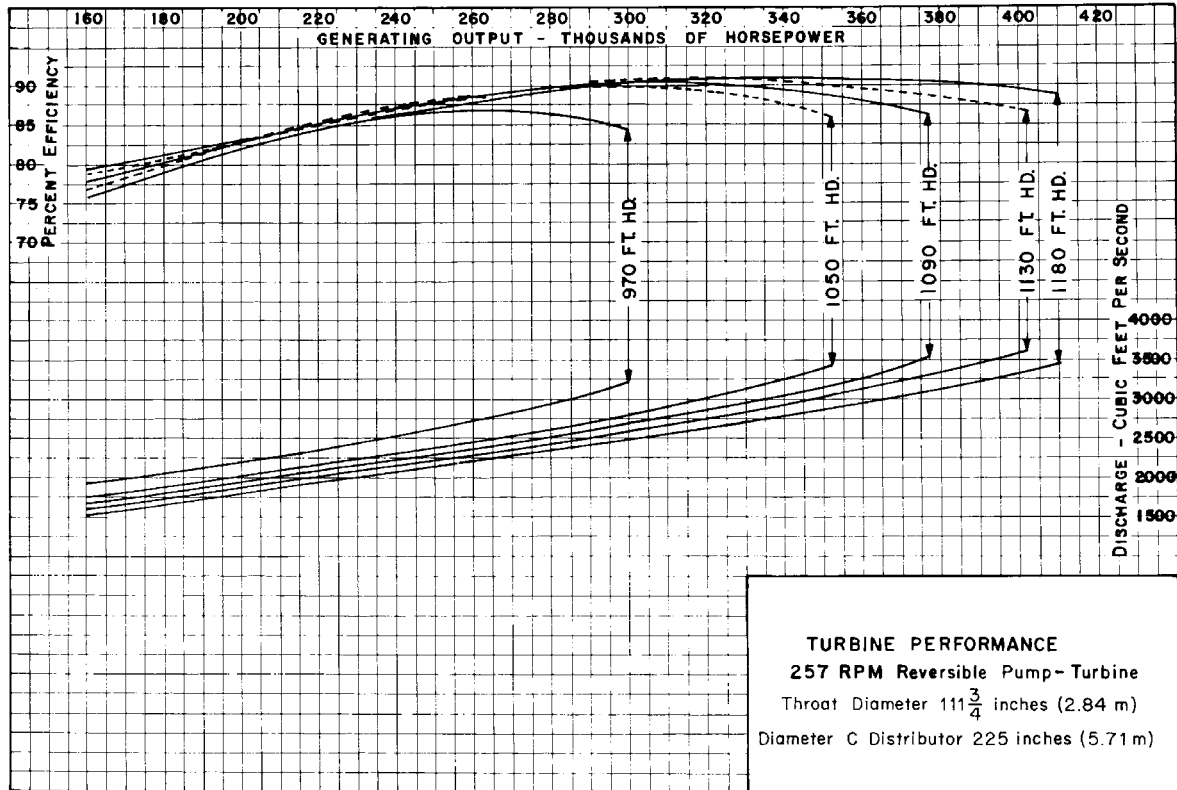
FIGURE 5 Typical cavitation model test (1 ft<sup>3</sup>/s = 0.0283 m<sup>3</sup>/s) (Voith Siemens Hydro)

**Pumping Mode** If we attempted to start the unit as a pump, from rest and with the spiral case and draft tube filled, the power and inrush current would be excessive. Accordingly, the standard type of compressed air system is provided to depress the tailwater elevation to below the bottom of the impeller, with the wicket gates closed. The load to be overcome at starting then consists of the load of the rotating masses, which must be accelerated to synchronous speed, and the load due to windage. Owing to inevitable leakage past the wicket gates, this windage is substantially greater than that due to dry air. The main penstock valves must also be closed during starting, or else the leakage and "wet" windage would be still further increased at the much higher head.

For the larger units generally employed, a separate starting motor, of the induction type with wound rotor, is mounted directly above the main generator motor. It has not been found feasible, in the motor space available, to design an amortisseur winding capable of sustaining the heat from the inrush current resulting from across-the-line starting of the main generator motor, even at reduced voltage. For the smaller units, however, this may be accomplished. In rare instances, where a main unit is always available, this spare may be electrically coupled to the pumping unit and the two started from rest in back-to-back synchronism. The separate starting motor is usually sized to bring the main unit up to synchronous speed in about 10 minutes, as shown by Figure 11.

When the unit has attained full speed, it is synchronized to the line, the compressed air is cut off, the tailwater rises to fill the draft tube, the wicket gates and main penstock valve are opened gradually to prevent shock, and pumping to the upper reservoir begins.

The maximum transient load on the generator motor thrust bearing occurs just as pumping begins. Prior to the advent of pumped storage, thrust bearings were designed to carry the weight of the rotating parts plus the hydraulic thrust at the steady-state condition. Now a greatly increased thrust of short duration must also be accommodated. Because of the short duration of this transient excess load, it may usually be carried safely by the bearing as designed for the steady-state requirement, depending on the detailed



**FIGURE 6** Turbine performance (1 ft<sup>3</sup>/s 0.0283 m<sup>3</sup>/s; 1 ft = 0.3048 m; 1 hp 0.746 kW) (Voith Siemens Hydro)



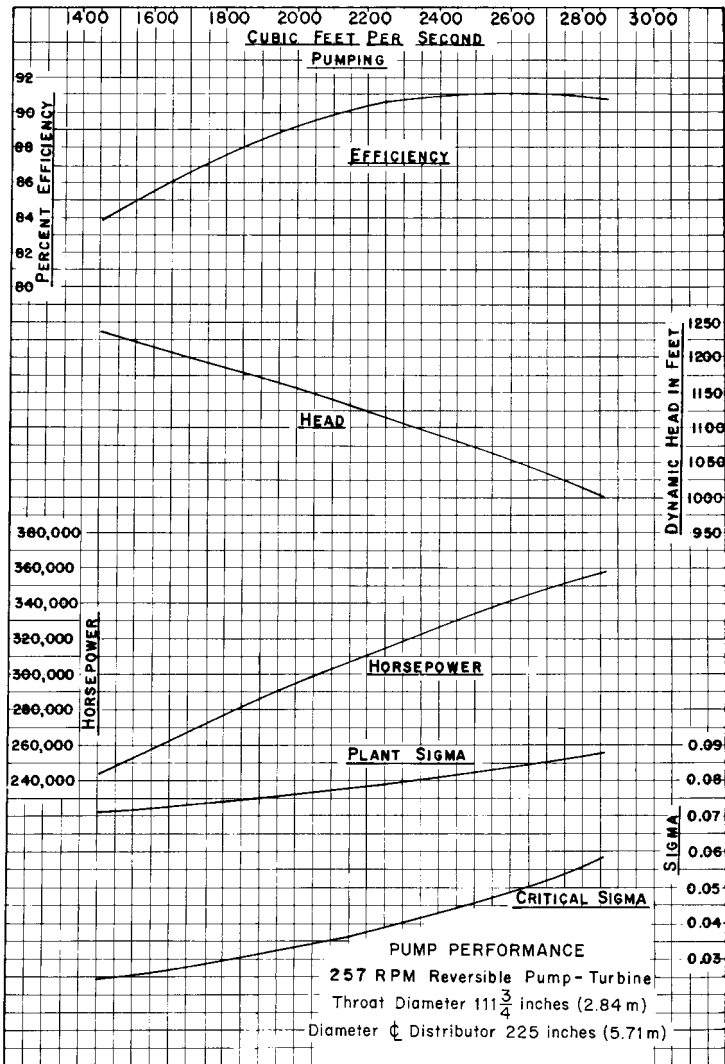
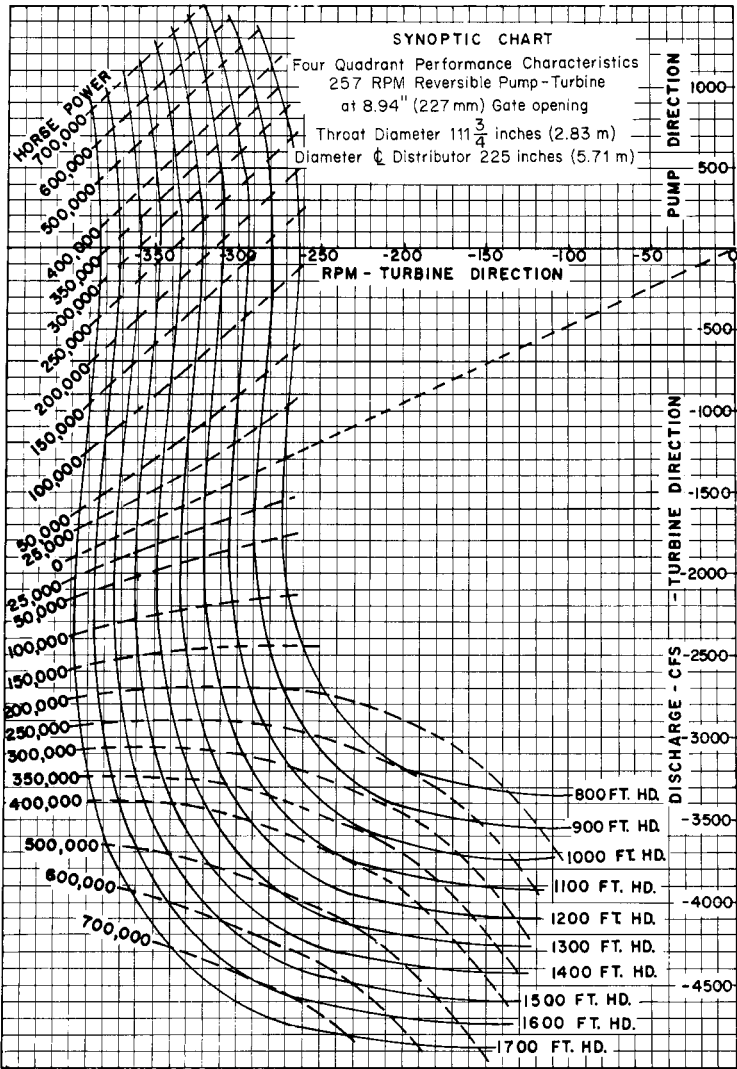


FIGURE 7 Pump performance (1 hp = 0.746 kW; 1 ft = 0.3048 m; 1 ft<sup>3</sup>/s = 0.0283 m<sup>3</sup>/s) (Voith Siemens Hydro)

design of the bearing. It is now standard practice to provide a high-pressure oil pumping system to ensure that there will be a film of oil between the bearing surfaces before the unit starts rotating.

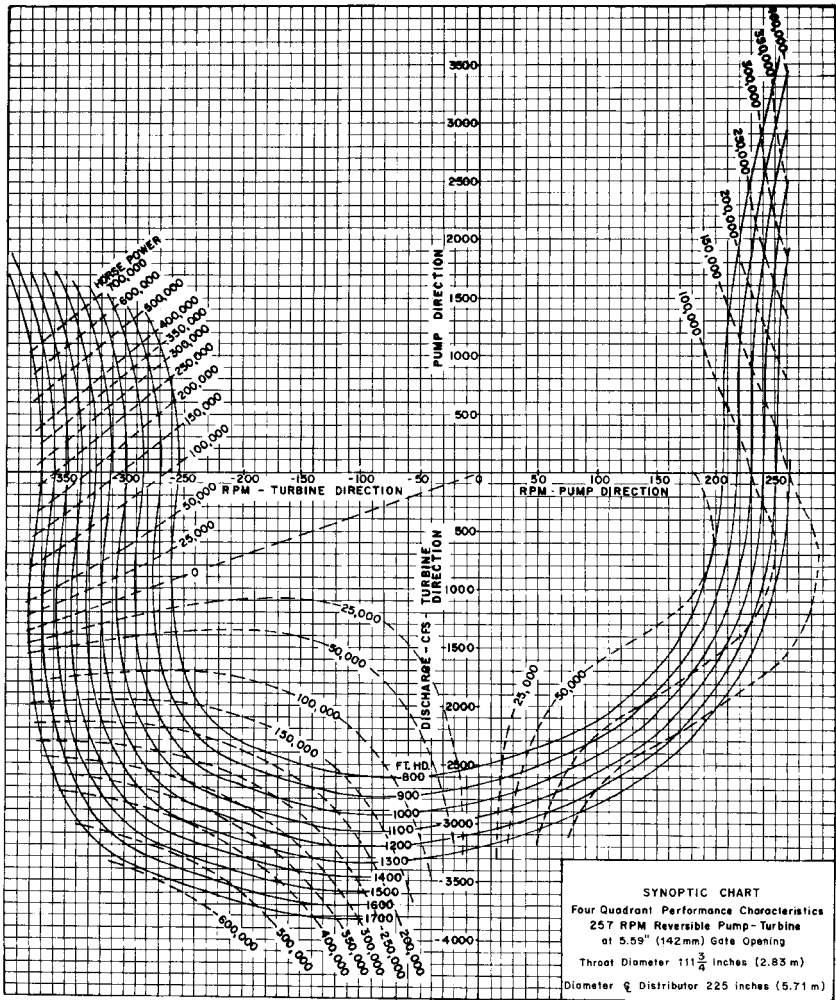
**Conventional Generation** For generation in the conventional manner, the unit may be started from rest under its own power without assistance from the starting motor.

**Rotating Spinning Reserve** In considering the requirements for starting the unit for rotating spinning reserve, it will be assumed that the utility is a participant in a grid sys-



**FIGURE 8A** Synoptic chart for an 8.94-in (227-mm) opening (1 hp = 0.746 kW; 1 ft = 0.3048m; 1 ft<sup>3</sup>/s = 0.0283 m<sup>3</sup>/s) (Voith Siemens Hydro)

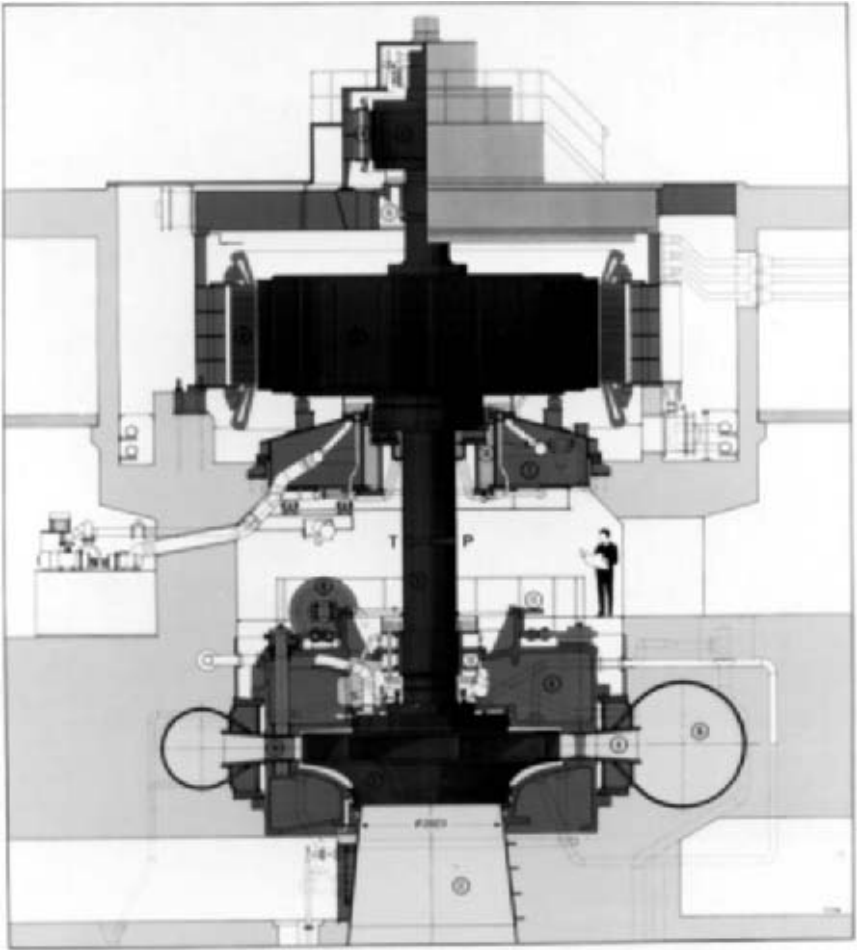
tem of interconnection by means of extra-high-voltage (EHV) transmission lines of high capability. This means that, immediately upon loss of generation by the local utility, the EHV connection will carry the necessary load for the short time required (about 30 s) for the local pumped storage units to absorb full load. In readiness for just such an emergency, these local pump turbines will be motoring on the line in the generating direction, with the wicket gates and main penstock valves closed and with the tailwater depressed. The loads and procedure for bringing the units up to speed for synchronizing to the line for rotating spinning reserve are identical with those given for operation in the pumping mode except that rotation is in the generating direction.



**FIGURE 8B** Synoptic chart for a 5.59-in (142-mm) opening (1 hp = 0.746 kW; 1 ft = 0.3048 m  $1 \text{ ft}^3/\text{s}$ ; = 0.0283  $\text{m}^3/\text{s}$ ) (Voith Siemens Hydro)

## GOVERNOR TIME AND SURGE TANKS

In pumped storage plants, the time specified for the governor servomotors to move the wicket gates through a complete stroke is generally not less than 30 s. The reasons for this are that (1) about 30 s is the minimum practicable time for penstock valve operation if the valve operating machinery is not to be made unduly complicated by the incorporation of dashpots and accessories and (2) one of the primary purposes of massive EHV connection is to carry loads from emergency outages for 30 to 60 s or more until the local pumped storage units take over. In the lengths of waterways that are permissible economically, penstock and tunnel velocities may usually be accelerated to full load in a much shorter time



**FIGURE 9** Pump-turbine with motor generator. Starting motor is located on top, above the motor-generator. The pump-turbine runner—surrounded by adjustable vanes, stay vanes, and spiral case—is located above the conical draft tube that has a minimum throat diameter at the runner eye of 2823 mm (111.1 in). In the turbine mode, flow is downward and out of the draft tube, and power generated is 210 MW at a head of 250 m (820 ft). In the pumping mode, the flow direction is reversed, and the motor input power is 198.1 MW at a head of 260 m (853 ft). Speed is 272.7 rpm in both modes (Voith Siemens Hydro)

without excessive positive or negative waterhammer, so surge tanks are not necessary. However, in the exceptional case of a long tailrace tunnel flowing as a closed conduit, under the relatively low head of tailwater, even a 30-s closure could be sufficient to produce negative waterhammer great enough to cause separation of the water column and damage to the unit. For such cases, a surge tank<sup>1</sup> at the downstream face of the power station is required. In a dual-purpose project for municipal water supply and by-product power, the length of the tunnel is dictated by water supply economics and may be as great as 40 to 50 miles (64 to 80.5 km). In such cases, a surge tank on the upstream side of the power station may be indicated.

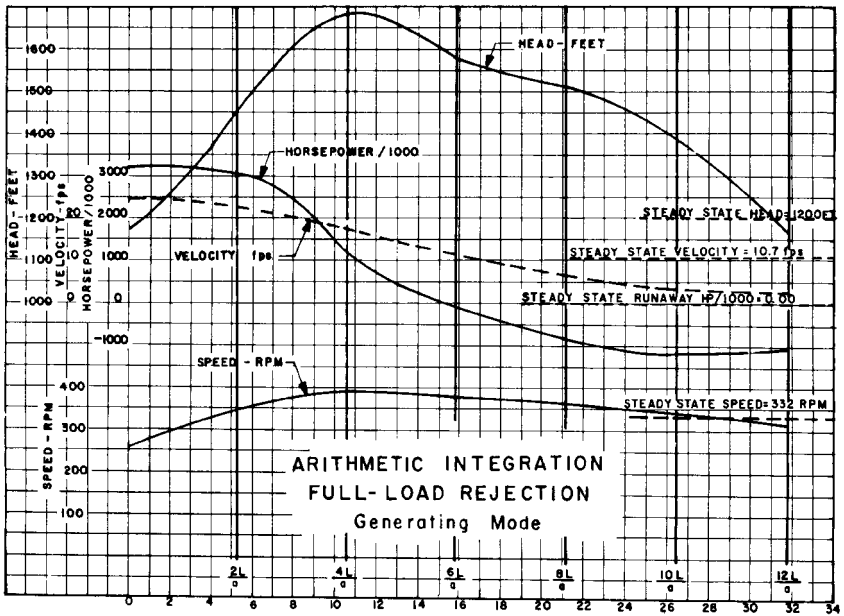


FIGURE 10 Arithmetic integration, full load rejection (1 hp = 0.746 kW; 1 ft = 0.3048 m; 1 ft/s = 0.3048 m/s; 1 ft<sup>3</sup>/s = 0.0283 m<sup>3</sup>/s) versus time in seconds.

## ECONOMIC DESIGN

A proposed pumped storage project for peaking service must be able to show a liberal margin of economic superiority over competing thermal types. This requires that the undertaking be designed in accordance with the so-called lean project concept, in which all elements are closely tailored to the specific purpose of pumped storage and many features considered standard in the conventional hydroelectric plant are found superfluous.

Selection of the proper site is of paramount importance. The rock should be strong and tight so no more than local grouting is needed to inhibit leakage and no drainage system for the concrete lining of the tunnels is required. The upper storage reservoir should preferably be located in a natural basin in elevated highlands to provide the requisite storage capacity by use of low rimdikes. It is a great advantage if the lower reservoir can be located on tidewater. The head, probably the most important natural feature, should be high, in the range from 500 to 1500 ft (152 to 457 m). High head means smaller water quantities and consequently smaller sizes for a given power output. High head also permits higher turbine speeds, lower torque, and a smaller generator. The intake need be only a bell mouth at the end of the supply tunnel; consequently, headgates, cranes, and accessories can be eliminated. The individual units should be of large capacity to ensure minimum equipment costs.

Table 3 shows a typical form for the economic comparison of pumped storage and competitive thermal peaking, and Table 4 is a typical form for the project cost estimate with its overheads.

Table 5 shows the range of machine requirements for a deep upper reservoir in which the head variation due to daily drawdown is relatively large. Note that the maximum electric motor load to develop the full hydraulic capability of the pump, occurring at the minimum head of 970 ft (296 m), is 297 MVA. However, this loading is of comparatively short duration and may be sustained at 80°C temperature rise, which corresponds to 115% of normal rating. The normal rating at 60°C temperature rise would then be  $\frac{297}{1.15}$ , or 258 MVA,

**TABLE 2** Arithmetic integration at full-load rejection (generating mode; wicket gates at 92% opening)

Interval $\frac{2L}{a}$	Time, s	Trial $V$ ( $\Delta V$ ), ft/s	$\Delta H$ , ft	$\Sigma \Delta H$ , ft	$H_f$ , ft	$H_o + H_f$ + $\Sigma \Delta H$ = total $H$ , ft	Trial speed, rpm	$Q$ (8 units), ft <sup>3</sup> /s	Check $V$ , ft/s	Hp, 8 units (000)	Average hp, 8 units (000)	$N^2$ , rpm <sup>2</sup>	$N_2^2 - N_1^2$ rpm <sup>2</sup>	Check $T$ , s
0	0	24.5	—	—	-36.8	1173.2	257	28,100 (3,510) <sup>a</sup>	24.7	3200	—	66,000		
1	5.3	-1.9 22.6	274	274	-28.8	1455.2	342	25,800 (3220)	22.6	3040	3120	117,000	51,000	5.30
2	10.6	-5.3 17.3	766	492	-16.9	1685.1	390	19,700 (2460)	17.3	1180	2110	152,000	35,000	5.30
3	15.9	-6.0 11.3	867	375	-7.2	1577.8	378	12,900 (1610)	11.3	-104	538	142,900	9100	5.30
4	21.2	-4.7 6.6	680	305	-2.5	1512.5	368	7520 (940)	6.6	-784	-444	135,500	-7400	5.30
5	26.5	-3.25 3.35	470	165	-0.6	1374.4	345	3819 (477)	3.35	-1200	-992	119,000	-16,500	5.30
6	31.8	-0.85 2.50	123	-42	-0.4	1167.0	316	2850 (256)	2.5	-1080	-1140	100,000	-19,000	5.30

$L = 12,322$  ft,  $A = 1140$  ft<sup>2</sup>,  $a = 4650$  ft/s,  $H_f = 0.0565V^2$ ,  $WR^2 = 1023 \times 10^6$  (8 units),  $2L/a = 5.3$  s,  $H_o = 1210$  ft,  $\Delta H = a \Delta V/g = (4650 \times \Delta V)/32.2 = 144.5 \Delta V$

$$\Delta T = \frac{4\pi WR^2(N_2^2 - N_1^2)}{2g \times \text{av. hp} \times 550 \times 3600} = \frac{4\pi^2 \times 1023 \times 10^6(N_2^2 - N_1^2)}{64.4 \text{ av. hp} \times 550 \times 3600} = \frac{320(N_2^2 - N_1^2)}{\text{av. hp}}$$

SI conversions: m/s = 0.3048 × ft/s; m = 0.3048 × ft; m<sup>3</sup>/s = 0.0283 × ft<sup>3</sup>/s; kW = 0.746 × hp.

<sup>a</sup>Values in parentheses are per-unit values.

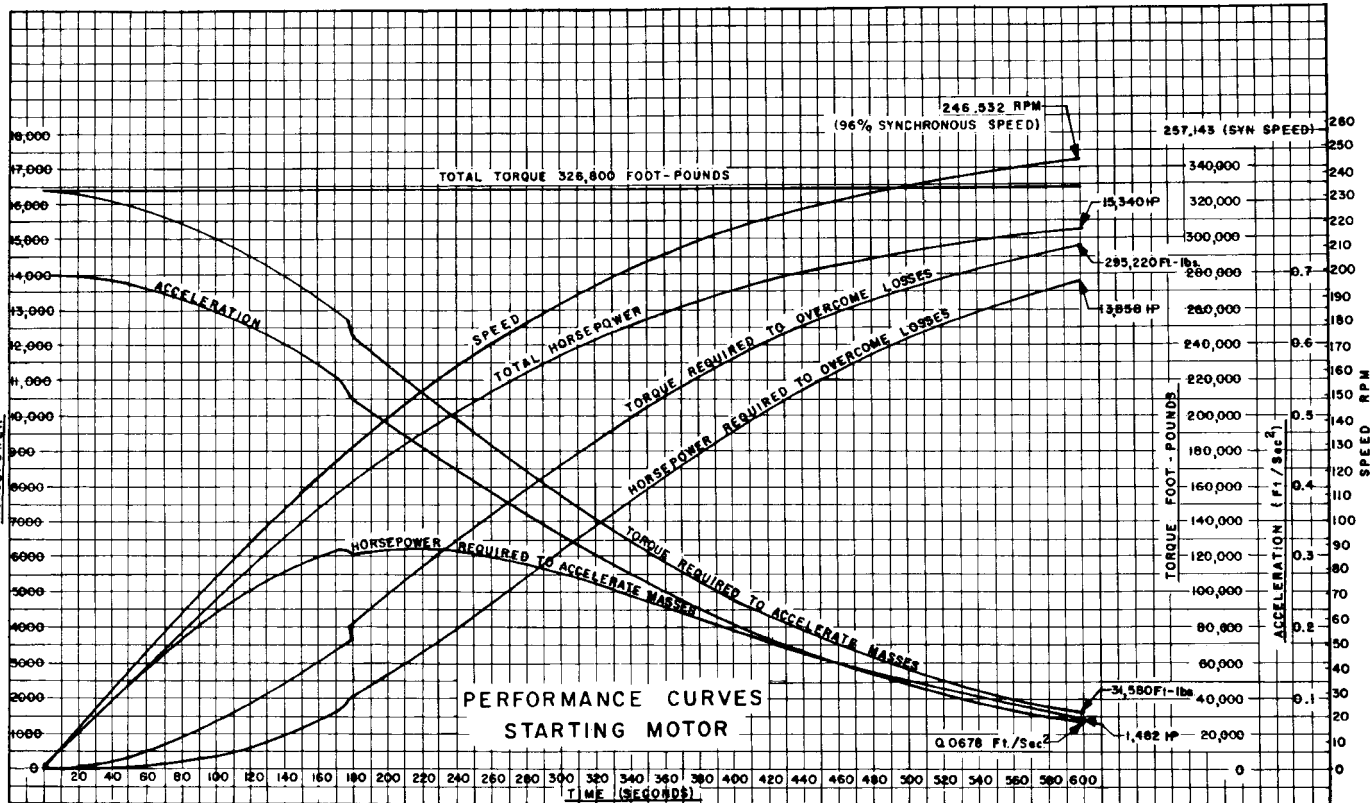


FIGURE 11 Performance curves, starting motor (1 hp = 0.746 kW; 1 ft · lb = 0.138 kg · m)

**TABLE 3** Economic evaluation of hypothetical pumped storage plant versus conventional steam reheat plant

		Reheat		Pumped storage	
Installed capacity MW		3,600		3,600	
Number of units		4		16	
Plant investment (000 omitted)					
Generation		\$450,000		\$260,000	
Transmission		—		47,100	
Total		\$450,000		\$307,100	
Total per kilowatt		\$ 125		\$ 85	
Annual generation (10 <sup>6</sup> kW · h)					
Peak load		1,300		1,300	
Base load		20,000			
Total		21,300		1,300	
Annual capacity factor, %		67.5		4.1	
Annual fixed charge rates, %					
Generating plant		13.35		10.90	
Transmission plant		—		11.35	
Annual costs	Total (000)	Per kW · yr	Total (000)	Per kW · yr	
Fixed charges					
Generating plant		\$ 60,076	\$16.69	\$28,340	\$ 7.87
Transmission plant		—	—	5,347	1.49
Total		\$ 60,076	\$16.69	\$33,686	\$ 9.36
Fuel		59,044	16.40	5,018 <sup>a</sup>	1.39
Operation and maintenance		9,900	2.75	3,492	.97
Total		\$129,020	\$35.84	\$42,196	\$11.72
Credit to reheat unit:					
Replacement for base					
Load generation		68,480	19.02		
Net cost of 3600-MW capacity and peak-load generation		\$ 60,540	\$16.82	\$42,196	\$11.72
Differential annual cost in favor of hypothetical plant				\$ 9,172	\$ 5.10

<sup>a</sup>Fuel cost for pumping energy.**TABLE 4** Hypothetical pumped storage plant cost estimate-summary

Account no.	Item	Cost
330	Land and land rights	\$ 4,311,000
331	Structures and improvements	
-1	Powerhouse substructure	20,791,000
-2	Service bay substructure	2,023,000
-3	Powerhouse superstructure	553,200
-4	Cofferdam	600,000
332	Reservoirs, dams, and waterways	
-2	Reservoir clearing	123,000
-4	Dikes and embankments	25,162,000
-8	Intakes	1,203,000
-12	Power tunnels and waterways	76,526,500
	Tailrace	4,940,000



Account no.	Item	Cost
333	Waterwheels, turbines, and generators	
-2	Fire protection system	86,000
-5	Motor generators	31,776,800
-8	Spherical valves	7,680,000
-9	Turbines and accessories	23,915,520
-11	Piezometer system	24,000
-13	Spiral case and draft tube unwatering systems	136,000
	Air depression system	208,000
	Draft tube racks, piers, and guides	2,071,600
334	Accessory electrical equipment	6,496,000
335	Miscellaneous power plant equipment	2,046,000
335	Roads, railroads, and bridges	2,393,600
352	Transmission plant—structures and improvements	2,226,500
353	Station equipment	12,119,400
		<u>\$222,412,120</u>
	Contingencies, overhead, and engineering	32,587,880
	Total estimated cost of project	<u>\$260,000,000</u>

**TABLE 5** Operating range of hypothetical project

	Reservoir elevation, ft			
	1000	1060	1120	1160
Tailwater elevation, ft	0	0	0	0
Gross head, ft	1000	1060	1120	1160
Generating cycle				
Friction head loss, ft	30	30	30	30
Net head, ft	970	1030	1090	1130
Best gate turbine output, hp (000)	—	310		
Full-gate turbine output, hp (000)	310	—	380	400
Turbine output blocked at, hp (000)	—	—	350	350
Turbine efficiency, %	85	88.3	87.5	88.5
Turbine discharge, ft <sup>3</sup> /s	3300	3000	3200	3100
Generator output at 98% efficiency, MW	227	227	256	256
Generator MVA (0.90 PF)	252	252	284	284
Pumping cycle				
Frictional head loss, ft	20	20	20	20
Net head, ft	1020	1080	1140	1180
Maximum possible discharge, ft <sup>3</sup> /s	2700	2350	2000	1730
Pump power, hp (000)	350	324	298	277
Pump efficiency, %	89.5	89	87	84
Motor power, at 98% efficiency, MW	262	242	223	206
Motor MIVA (0.90 PF)	297	275	252	234

SI conversions: m = 0.3048 × ft; kW = 0.746 × hp; m<sup>3</sup>/s = 0.0283 × ft<sup>3</sup>/s.

which is shown by the tabulation to be adequate to carry pumping and generating loadings of more protracted duration. This utilization of overload rating for Class B insulation affords substantial economies in electric machine cost.

**REFERENCE**

---

1. Rich, G. R. *Hydraulic Transients*, Dover, New York, 1963.

**FURTHER READING**

---

American Society of Mechanical Engineers. *Waterhammer in Pumped Storage Projects*. ASME, New York 1965.

Chapin, W. S. "The Niagara Power Project." *Civ. Eng.*, April 1961, p. 36.

Davis, C. V., and Sorensen, K. E. *Handbook of Applied Hydraulics*. McGraw-Hill, New York, 1969.

McCormack, W. J. "Taum Sauk Pumped-Storage Project as a Peaking Plant." *Water Power*, June 1962.

Parmakian, J. *Waterhammer Analysis*, Dover, New York, 1963.

Rich, G. R., and Fisk, W. B. "The Lean Project Concept in the Economic Design of Pumped-Storage Hydroelectric Plants." Paper presented at World Power Conference, 60, September 1964.

Rudolph, E. A. "Taum Sauk Pumped Storage Power Project." *Civ. Eng.*, January 1963.

---

# SECTION 9.14

---

# NUCLEAR

---

## 9.14.1

### NUCLEAR ELECTRIC GENERATION

W. M. WEPFER  
W. E. PARRY, JR.

#### **APPLICATION**

---

The primary difference between the pumps for nuclear service and conventional steam generation is the stringent requirements for reliability and safety. The continuous functioning of nuclear pumps is critical to the safe operation of the plant. In addition, many of these units maintain the responsibility of ensuring safe shutdown of the facility during emergency conditions. Because the release of radioactive fluids could result in potential personnel and environmental hazards along with associated costly clean-up, nuclear pumps must be self-contained. The rules and regulatory standards for nuclear pumps are dedicated to the promotion of public safety through reliable operation. Pump manufacturers must be fully knowledgeable of these standards and certified by the American Society of Mechanical Engineers (ASME) (or an equivalent authority outside the United States) before they can offer pumps for the nuclear market.

All nuclear power plants built for public utility service involve the generation of steam. The method of steam generation differentiates the two major types of plants. The pressurized water reactor (PWR) employs two distinct systems, a primary and a secondary loop. The primary loop circulates pressurized radioactive fluid from the reactor to the steam generator where it heats the secondary fluid. The secondary loop directs steam from the steam generator to the turbines and condensed fluid back to the generators. A boiling water reactor (BWR), on the other hand, only employs one loop. The steam is generated in the reactor and then circulated through the turbines, condensers, and heaters and back to the reactor.

It is usual for the plant to contain one major system, or loop, and a number of supporting systems. Because virtually every system requires some form of pumping, it is conventional to designate each pump by the name of the system with which it is associated. For each of the systems previously discussed, the main and auxiliary systems are reviewed, including brief descriptions of the pumping requirements.

**PWR Plants** Pressurized water reactor (PWR) plants employ two separate main systems to generate steam. In the primary system, the water is circulated by *reactor coolant pumps* through the nuclear reactor and large steam generators. Overpressure is provided to prevent vapor formation. The secondary side of the steam generator provides nonradioactive steam to the turbogenerator. Typical primary water conditions are 2250 lb/in<sup>2</sup> gauge (15.51 MPa) and 550°F (288°C). Table 1 lists the parameters of the more important pumps used in PWR plants.

Figure 1 is a simplified flow diagram of a PWR reactor coolant system. Only one primary loop is shown, but in practice, plants use two, three, or four loops in parallel, each loop consisting of its own reactor coolant pump, steam generator, and optional stop valves. A single reactor and pressurizer supply all loops. The pressurizer provides the overpressure referred to by maintaining a body of water at an elevated temperature such that its vapor pressure satisfies the primary loop pressure requirements.

In the PWR plant, high-pressure water circulates through the reactor core to remove the heat generated by the nuclear chain reaction. Figure 2 is an illustration of a typical PWR reactor vessel. The heated water exits from the reactor vessel and passes via the coolant loop piping to the primary side of the steam generators. Here it gives up its heat to the feedwater to produce steam for the turbogenerator. The primary-side cycle is completed when the reactor water is pumped back to the reactor by the reactor coolant pumps. The secondary-side cycle, isolated from the primary loops, is completed when the *feedwater pumps* return water to the secondary side of the steam generator.

Because a reactor, after it has been critical, continues to generate heat even when shut down, *residual heat removal (RHR) pumps* are provided to circulate reactor water through coolers any time the reactor is inoperable and at low pressure, even during refueling. These pumps serve other functions also, as described next.

The chemical and volume control system (Figure 3) performs a number of functions. Through *charging pumps*, which may be centrifugal or positive displacement or may include some of each type, the primary system can be filled and pressurized when cold. When the system is hot, the pumps are used to maintain the water level in the pressurizer and to replenish any fluid drawn from the primary loops by other systems. Additionally, the pumps supply clean water to the reactor coolant pump seals and are used to adjust the boric acid concentration in the reactor coolant water, which provides an auxiliary means of reactor power regulation. If positive displacement pumps are included in the chemical and volume control system, they are also used to hydrostatically test the reactor primary coolant system. Where all the charging pumps are centrifugal, it is customary to provide a small positive displacement pump exclusively for this hydrostatic testing.

For cooling essential components and for supplying a variety of heat exchangers, a component cooling water system is provided. *Component cooling water pumps* circulate clean water at low system pressures for the purpose of cooling (1) primary water, which is continuously bled for purification, (2) main and auxiliary pump bearings and seals, (3) primary pump thermal barriers, (4) large motors, (5) the containment vessel, and (6) the spent fuel pit water.

When the primary pressure boundary is breached, elements of the emergency core cooling system (ECCS) are immediately activated. The primary function of the ECCS following a loss-of-coolant accident is to remove the stored and fission product decay heat from the reactor core. The safety injection system (Figure 4) does most of this. Upon actuation of the safety injection signal, the charging pumps inject boric acid solution, which is stored in special tanks and continuously circulated by the *boron injection recirculation pumps*, into the reactor coolant system. At the same time, the *residual heat removal pumps* are started. These pumps take suction from a large refueling water storage tank and inject cold water into the reactor coolant circuit. To provide additional capacity, the *safety injection pumps* are started, taking suction from the cold water in the refueling water storage tank and pumping this water into the reactor coolant system. If the large storage tank should run dry, these pumps will take suction from the containment sump.

Operated by a pressure signal, *containment spray pumps* condense any steam in the containment in order to lower the temperature and pressure in that environment. By taking suction from the containment sump, these pumps continue to circulate water through spray nozzles located near the top of the containment until the pressure has been reduced to an acceptable level.

**TABLE 1** Typical nuclear pump parameters in PWR plants

Pump	Number per plant	Flow, gpm (m <sup>3</sup> /h)	Head, ft (m)	Design pressure, lb/in <sup>2</sup> (MPa)	Design temp., °F (°C)	Driver hp (kW)	Shaft	Length or height, including driver, in (mm)	Speed (nominal), rpm	Notes
Reactor coolant	4	100,000 (22,700)	290 (88)	2500 (17.2)	650 (343)	7000 (5220)	Vert.	305 (7750)	1200	
Component cooling water	3	4800 (1090)	250 (76)	200 (1.38)	200 (93)	450 (336)	Horiz.	110 (2790)	1800	
Residual heat removal	2	3800 (863)	350 (107)	600 (4.14)	400 (204)	500 (373)	Vert.	97 (2460)	1800	
Containment spray	2	2600 (590)	450 (137)	300 (2.07)	300 (148)	400 (298)	Horiz.	112 (2840)	1800	
Spent fuel pit cooling	3	4500 (1022)	150 (46)	150 (1.03)	200 (93)	250 (186)	Horiz.	87 (2210)	1800	
Charging (centrifugal)	2	120 (27)	5800 (1768)	2800 (19.3)	300 (148)	600 (448)	Horiz.	234 (5940)	4850	Gear drive
Charging (reciprocating)	1	98 (22)	5800 (1768)	2800 (19.3)	250 (121)	200 (149)	Horiz.	208 (5280)	205	Reciprocating
Safety injection	2	440 (100)	2680 (817)	1750 (12.07)	300 (148)	450 (336)	Horiz.	190 (4830)	3600	
Chilled water	2	400 (91)	150 (46)	150 (1.03)	200 (93)	40 (30)	Horiz.	52 (1320)	3600	
Spent resin sluicing	1	150 (34)	250 (76)	240 (1.66)	250 (121)	30 (22)	Horiz.	46 (1170)	3600	
Reactor coolant drain tank	2	150 (34)	250 (76)	240 (1.66)	250 (121)	30 (22)	Horiz.	46 (1170)	3600	

TABLE 1 Continued.

Pump	Number per plant	Flow, gpm (m <sup>3</sup> /h)	Head, ft (m)	Design pressure, lb/in <sup>2</sup> (MPa)	Design temp., °F (°C)	Driver hp (kW)	Shaft	Length or height, including driver, in (mm)	Speed (nominal), rpm	Notes
Boric acid transfer	2	100 (22.7)	200 (61)	150 (1.03)	200 (93)	15 (11)	Horiz.	45 (1140)	3600	
Boron recycle evaporator feed	2	100 (22.7)	200 (61)	150 (1.03)	200 (93)	15 (11)	Horiz.	45 (1140)	3600	
Boron injection recirculation	2	20 (4.5)	100 (30.5)	240 (1.66)	200 (93)	3 (2.2)	Horiz.	18 (460)	3600	Canned
Spent fuel pit skimmer	1	100 (22.7)	50 (15.2)	150 (1.03)	200 (93)	3 (2.2)	Horiz.	42 (1070)	1800	
Refueling water purification	1	200 (45)	200 (61)	150 (1.03)	200 (93)	30 (22)	Horiz.	52 (1320)	1800	
Waste processing system	5	100 (22.7)	200 (61)	150 (1.03)	200 (93)	15 (11)	Horiz.	45 (1140)	3600	
Gas decay tank drain	1	10 (2.27)	90 (27)	150 (1.03)	180 (82)	3 (2.2)	Horiz.	15 (380)	3600	
S. G. blowdown—spent resin sluice	1	110 (25)	165 (50)	150 (1.03)	100 (37)	15 (11)	Horiz.	39 (990)	3600	

Source: Westinghouse Electric.

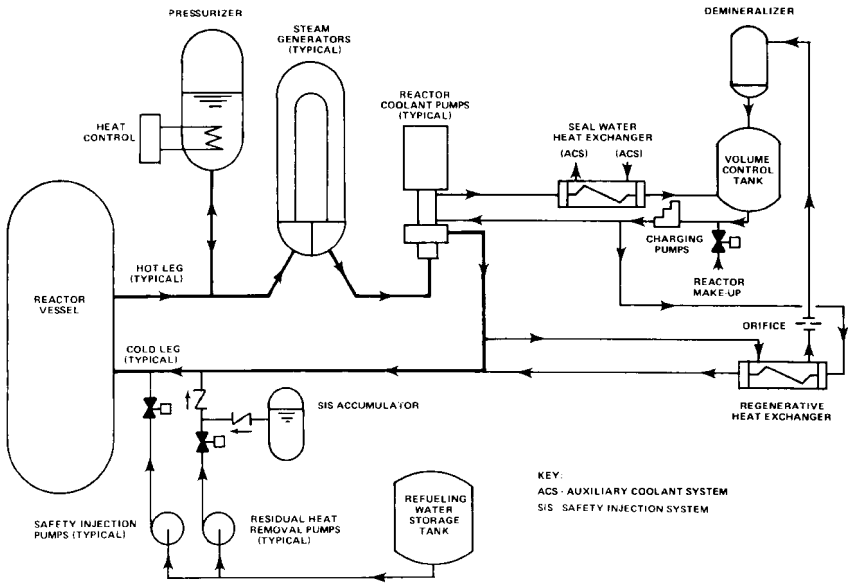


FIGURE 1 Flow diagram for pressurized water reactor coolant system (Westinghouse Electric)

All of the pumps and vital equipment associated with pipe rupture (that is, the emergency core cooling system) is supplied with diesel generator electrical power backup. If needed, the diesel generators will accept the various pump loads sequentially at intervals of a few seconds until all needed equipment is on line.

Other pumps serve other systems. *Spent fuel pit pumps* provide the necessary cooling of the fuel elements that have been removed from the reactor. Resin beds, which are a part of the water purification system, are flushed to a storage tank by *spent resin sluicing pumps*. An evaporator package, partly for removing boron from the primary water, is supplied by *recycle evaporator feed pumps*. *Chilled water pumps* supply the boron thermal regeneration system. Similarly, other pumps, some not listed in Table 1, support other systems.

**BWR Plants** In boiling water reactor (BWR) plants, active boiling takes place in the nuclear core and steam is piped to the turbogenerator (Figure 5). Typical reactor water conditions are 1000 lb/in<sup>2</sup> gauge (6.895 MPa) and 550°F (288°C). In the United States, the plant is usually arranged with a low-leakage containment vessel completely surrounding a dry well and a pressure-suppression pool (Figure 6). The containment vessel is a cylindrical steel or concrete structure with an ellipsoidal dome and a flat bottom supported by a reinforced concrete mat. The containment forms a security barrier and prevents the escape of radioactive products to the atmosphere if an accident should occur.

Table 2 shows the principal pumps used in BWR plants together with significant characteristic data.

To assure a high reactor flow rate and to avoid local areas of core overheating, internal *jet pumps* have been used in all but the earliest U.S. BWR plants. These jet pumps are driven by large-volume, medium-head *recirculation pumps*. Variable flow rate is achieved either by flow control valves or by variable-speed motors driven by motor generator sets. The latest designs employ a flow control valve. The use of jet pumps decreases the size of the external loop piping and pumps and provides a core reflood capability in the event of pipe rupture. The main recirculation pumps are not required for emergency cooling. In

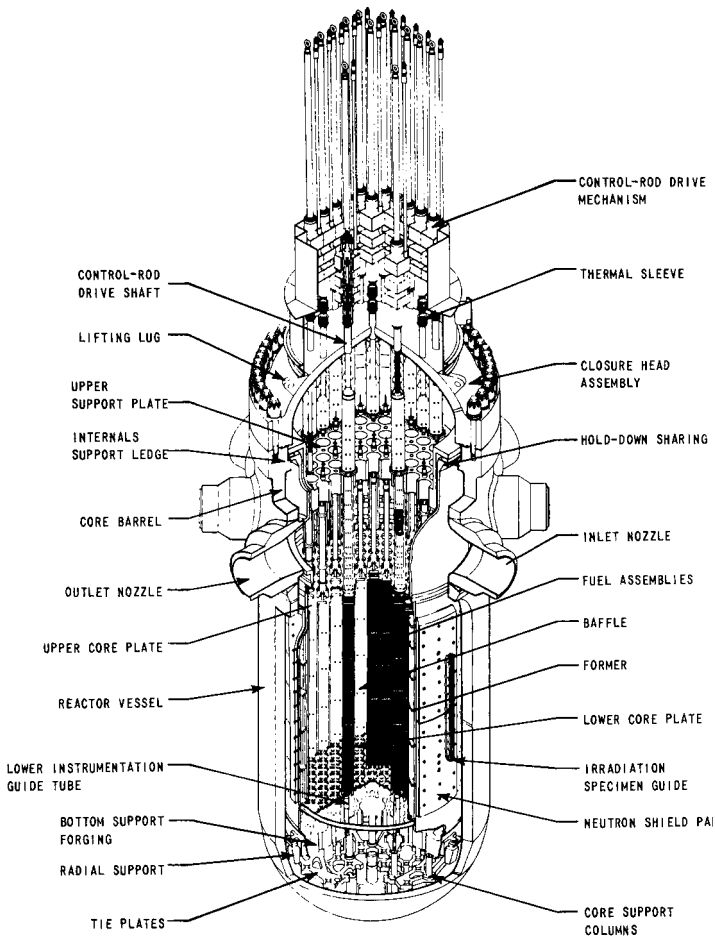


FIGURE 2 PWR reactor vessel (Westinghouse Electric)

normal operation, the recirculation pumps operate in conjunction with the jet pumps, which are wholly contained in the reactor vessel. The purpose of the jet pumps is to increase the flow from the recirculation pumps at reduced head for reactor cooling. The jet pumps have no moving parts. In addition to their normal service, they also play a role in the natural circulation of the reactor water during emergency cooling.

Several subsystems operate in support of the recirculation system, and each contains one or more pumps. *Reactor water cleanup pumps* are used in a filter-demineralizer system to remove particulate and dissolved impurities from the reactor coolant. This system also removes excess water from the reactor. The control rods are operated hydraulically with water pressure provided by the *control rod drive pumps*. The pumps are located in an auxiliary building, and the fluid is piped to the control rod drive units, which are posi-



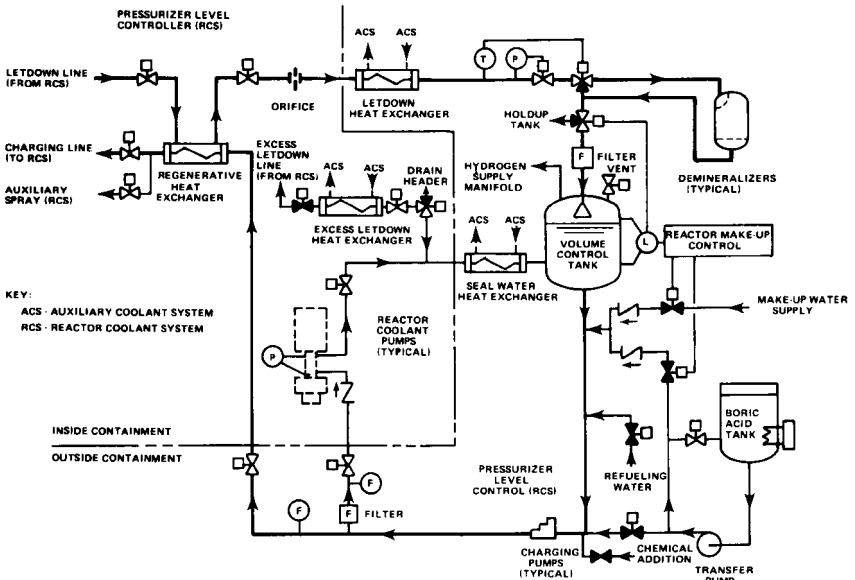


FIGURE 3 Flow diagram for chemical and volume control system (Westinghouse Electric)

tioned directly under the reactor vessel. For those components that require constant cooling, such as the recirculation pump motors and other equipment located in the containment, auxiliary, fuel, or radwaste buildings, *closed cooling water pumps* furnish the necessary flow. These pumps are located in an auxiliary building to permit ready access for servicing if needed. The system is closed so it can be isolated from an ultimate, usually raw water, heat sink, such as a river, lake, or ocean.

To cool the fuel stored under water in the fuel building and the water in the upper containment, separate *fuel pool cooling pumps* are provided in an independent system.

The emergency core cooling system is in reality an array of subsystems providing the necessary features, including redundancy, to protect the core in case of a significant malfunction. The high-pressure core spray system uses a vertical *high-pressure core spray pump*, motor-driven but backed by a diesel generator in event of loss of electric power. This pump, a single unit, provides the initial response when a small pipe breaks or an equivalent malfunction occurs. Should this system be inadequate to maintain reactor water level, the reactor vessel is automatically depressurized and the *low-pressure core spray pumps* supply additional capacity. As an added safeguard, the *RHR pumps* are used in a secondary-mode operation to inject cooling water directly into the reactor vessel. If steam should enter the containment region, the *RHR pumps* operate in another mode—as containment spray pumps—and are manually operated to condense the steam and thus reduce any potential pressure buildup in the containment. The *RHR pumps* function when needed to limit the temperature of the water in the suppression pool. The turbine-driven *reactor core isolation cooling pumps*, in a redundant and independent system, inject cool water into the reactor vessel. The *standby liquid control system pumps* inject boron solution into the reactor for alternative shutdown.

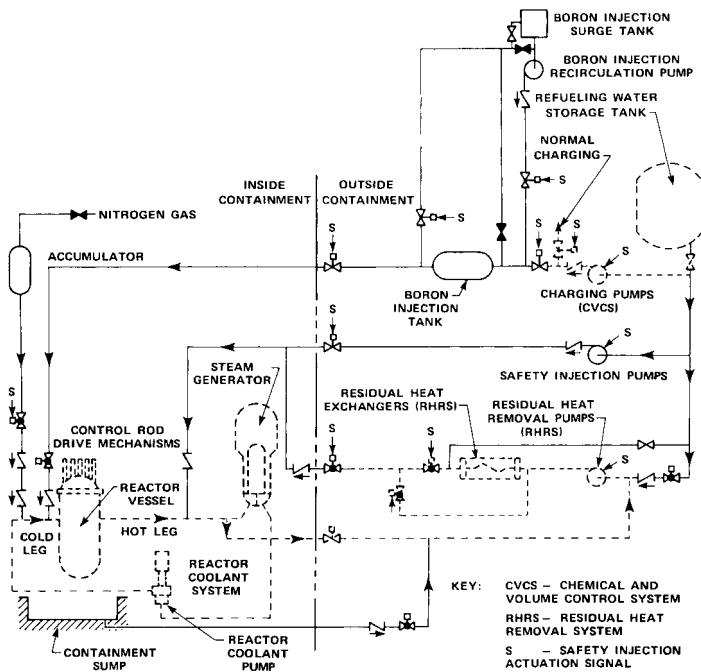


FIGURE 4 Flow diagram for safety injection system (Westinghouse Electric)

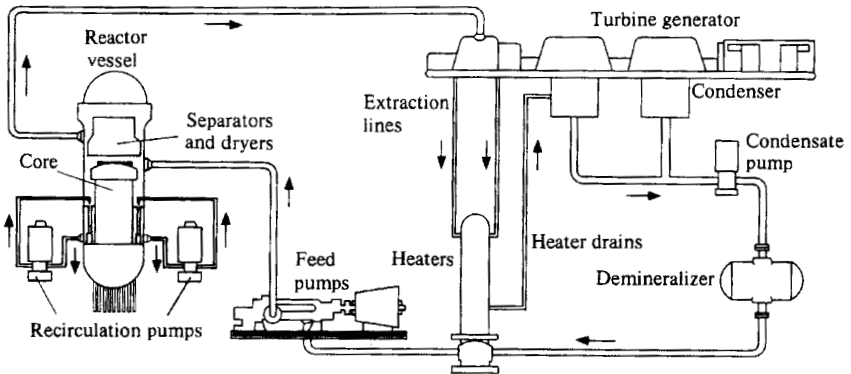
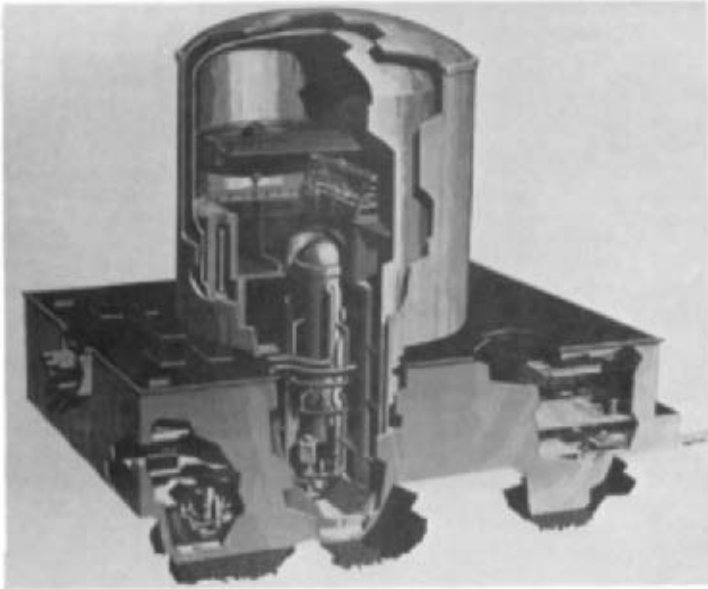


FIGURE 5 Boiling water direct cycle reactor system (General Electric)

**Additional Equipment** In addition to these systems, a number of support systems exist, most of which require some form of pumping. Without attempting to describe their systems, there are, for example, pumps for feedwater, condensate, chilled water, booster service, condenser service, demineralized water transfer, condensate transfer, dry-well drain, containment drain, concentrated borated water tank, water leg, precoat, radwaste, and sample station.



**FIGURE 6** BWR containment and reactor vessel, showing one of two external recirculation pumps (General Electric)

## MAIN COOLANT PUMPS

The term *main coolant pumps* as used here includes both the *recirculation pumps* in BWR plants and the *reactor coolant pumps* in the primary systems of PWR plants. As shown typically in Figures 7, 8, 9, and 10, main coolant pumps use a vertical shaft with the impeller at the bottom and a drive motor coupled to the top end of the shaft.

**Bearings** Main coolant pumps are usually single-bearing units, although one manufacturer provides a second guide-and-thrust oil-lubricated bearing just below the coupling. Within the pump, hydrodynamic water-lubricated bearings are conventionally used (one supplier using a hydrostatic type). The hydrodynamic bearing generally consists of a hardened sleeve journal shrunk on the shaft and a carbon-lined bearing with some type of self-aligning feature. Bearing diametral clearances are approximately 1.5 mils per inch of bearing diameter (0.0015 mm per millimeter). This rather large clearance is desirable because of thermal transient conditions. Where carbon bearings are used, a cooling mechanism must be provided because the carbon is not suited to long exposure in a hot environment. Many methods are available to accomplish this.

With bearings adequately sized and operating in clean water, virtually trouble-free performance can be expected even with relatively frequent starts and stops.

The hydrostatic, or pressurized, bearing is used where it is not convenient or desirable to provide bearing cooling, for the hydrostatic bearing can be designed to operate in reactor temperature water. Usually it will be larger than its hydrodynamic equivalent and somewhat more sensitive to starting because of the metal-to-metal rubbing that occurs until rotative speed has built up a small pressure to provide a water film clearance. At normal operating speed, however, a hydrostatic bearing will have a significantly larger lubricating film than a hydrodynamic bearing and can tolerate larger particulate matter without wear.

An exception to the previous discussion occurs in both German and Swedish BWR designs, where the recirculation pumps are inverted and inserted directly into the bottom

**TABLE 2** Typical nuclear pump parameters in BWR plants

Pump	Number per plant	Flow, gpm (m <sup>3</sup> /h) <sup>a</sup>	Head, ft (m)	Design pressure, lb/in <sup>2</sup> (MPa)	Design temp., °F (°C)	Driver hp (kW) <sup>a</sup>	Shaft	Length or height, including driver, in (mm)	Speed (nominal), rpm	Notes
Recirculation coolant	2	44000 (9993)	760 (231)	1675 (11.55)	575 (302)	8000 (5970)	Vert.	240 (6096)	1800	
RHR service water	4	7300 (1658)	115 (35)	150 (1.03)	150 (65)	300 (224)	Vert.	200 (5080)	900	
RHR	3	8520 (1935)	275 (84)	450 (3.10)	212 (100)	900 (670)	Vert.	350 (8890)	1800	
High-pressure core spray	1	1465 (333)	2600 (792)	1600 (11.03)	212 (100)	3000 (2240)	Vert.	500 (12700)	1800	
Low-pressure core spray	1	6000 (1363)	280 (85)	550 (3.79)	212 (100)	1750 (1310)	Vert.	400 (10160)	1800	
Closed cooling water	2	2040 (463)	110 (34)	150 (1.03)	212 (100)	60 (45)	Horiz.	100 (2540)	1800	
Reactor core isolation cooling	1	700 (159)	2600 (792)	1500 (10.34)	212 (100)	800 (597)	Horiz.	123 (3124)	4000	Turbine-driven variable-speed
Fuel pool cooling and cleanup	2	600 (136)	300 (91)	150 (1.03)	150 (65)	75 (56)	Horiz.	95 (2413)	1800	
Reactor water cleanup	2	150 (34)	500 (152)	1400 (9.65)	560 (293)	50 (37)	Horiz.	78 (1981)	3600	

**TABLE 2** Continued.

Pump	Number per plant	Flow, gpm (m <sup>3</sup> /h) <sup>a</sup>	Head, ft (m)	Design pressure, lb/in <sup>2</sup> (MPa)	Design temp., °F (°C)	Driver hp (kW) <sup>a</sup>	Shaft	Length or height, including driver, in (mm)	Speed (nominal), rpm	Notes
Control rod drive hydr. system	2	95 (22)	3500 (1067)	1750 (12.07)	150 (65)	300 (224)	Horiz.	168 (4267)	1800	
Standby liquid control	2	40 (9)	2800 (853)	1400 (9.65)	150 (65)	40 (30)	Horiz.	60 (1524)	1800	Reciprocating pumps
Jet	20	10000 (2271)	80 (24)	N.A.	575 (302)	N.A.	Vert.	250 (6350)	N.A.	
Waste evaporator	2	9000 (2044)	50 (15)	50 (0.35)	274 (134)	150 (112)	Horiz.	120 (3048)	720	
Resin tank precoat	1	255 (58)	85 (26)	150 (1.03)	150 (65)	10 (7.5)	Horiz.	65 (1651)	1800	

<sup>a</sup>Vary depending on reactor power rating.

Source: General Electric.

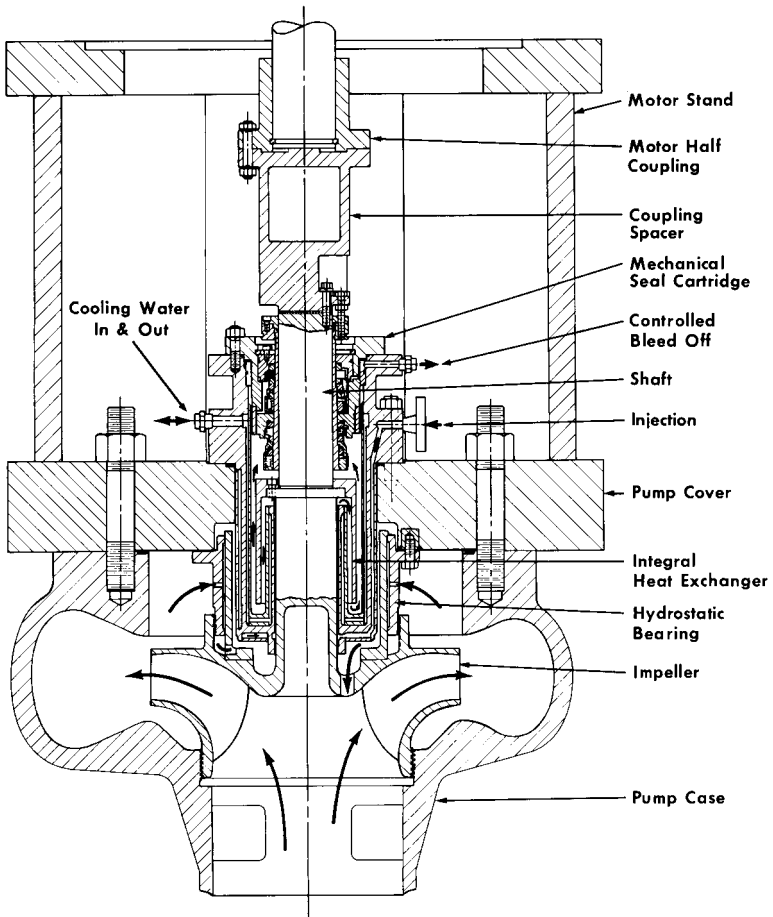


FIGURE 7 Main coolant pump (Flowserve Corporation)

periphery of the reactor vessel and use wet winding motors. There are no jet pumps. Flow is varied by changing motor speed with solid-state power supplies, one for each recirculation pump.

**Seals** Pump seals are invariably of the pressure-balanced type because of the high pressures involved. Several suppliers use pressure breakdown techniques to distribute the pressure either equally or in some desired proportion between two or more seals in series (Figure 11). The technique is analogous to that of a potentiometer, where particular voltages may be obtained by selecting the proper point along an electrical resistance. Also, as with a potentiometer, the flow through the primary resistance path must exceed the tapoff flow in order to maintain the system stability. For pressures in PWR systems, three series seals are frequently used (with each seal taking one-third of the overall pressure), and with lower-pressure BWRs, two series seals are usually sufficient. A margin of safety is built into the systems such that pump operation can be continued even if one of the series seals fails.

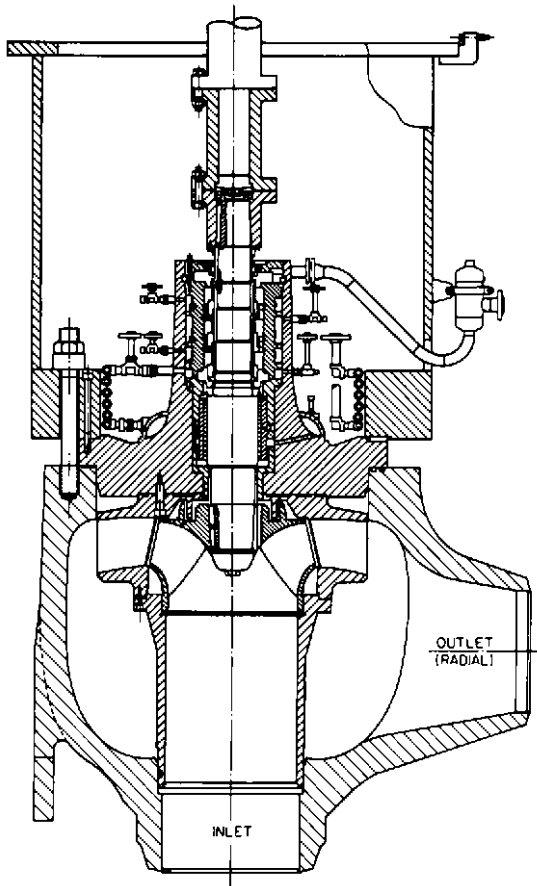
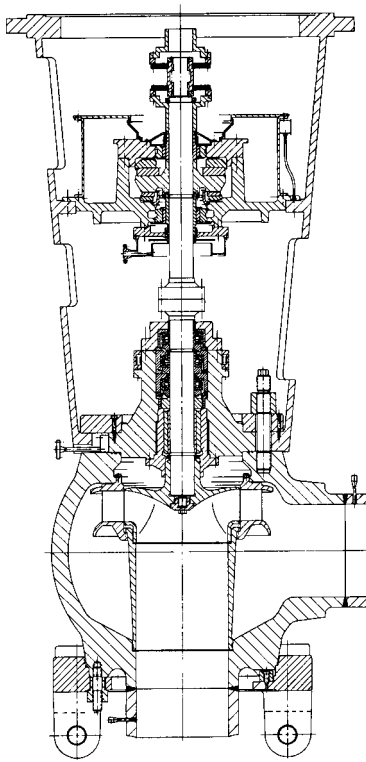


FIGURE 8 Main coolant pump (Sulzer Pumps)

In addition, a safety seal may also be installed as a backup. At least one manufacturer uses a high-pressure ceramic seal with a carbon seal backup followed by a vapor seal. Main coolant pump seals are usually supplied with reactor-grade water through a seal injection system. The advantage of using injection water is that it can be temperature-controlled and filtered. Most pumps, however, can be operated without it for at least reasonable time periods.

### PRINCIPAL TYPES OF PUMPS

Most of the pumps in nuclear service are one- or two-stage centrifugal motor-driven pumps. Both vertical and horizontal types are used. Charging, safety injection, feedwater, and other high-head pumps are usually multistage motor-driven centrifugal units. Some requiring high power are turbine-driven. Double-suction designs are frequently used for RHR pumps, where service requires operation at low available NPSH. Reciprocating



**FIGURE 9** Main coolant pump (CE-KSB Pump)

pumps find limited service in nuclear plants for make-up flow, seal injection flow, or chemical mixing service. Canned pumps are frequently used in subsystems where their zero-leakage capabilities can be exploited.

Figure 12 shows a multistage centrifugal pump used in charging and safety injection service.

Figure 13 illustrates a reciprocating pump often used for charging and hydrostatic test service. It is rated at 98 gpm (22 m<sup>3</sup>/h) at 5800 ft (1768 m) head. In Figure 14, a vertical multistage unit is shown. This type of unit is common in heater drain service. Figure 15 shows a single-stage pump of a type used in many service functions in a nuclear plant. Typically, its flow is 75 gpm (17 m<sup>3</sup>/h) with a developed head of 235 ft (71.6 m) at 3500 rpm.

### **SPECIAL REQUIREMENTS FOR NUCLEAR SERVICE PUMPS**

It is in the area of special requirements that nuclear service pumps differ most widely from commercial products. These special requirements, described in greater detail later, far exceed the requirements of the general industrial field and illustrate the strong emphasis placed upon pressure integrity and pump operability.

Nuclear-grade pumps are designed, built, inspected, tested, and installed to rigid standards of the U.S. Nuclear Regulatory Commission, the American Society of Mechanical Engineers, the American National Standards Institute, and other regulatory agencies,



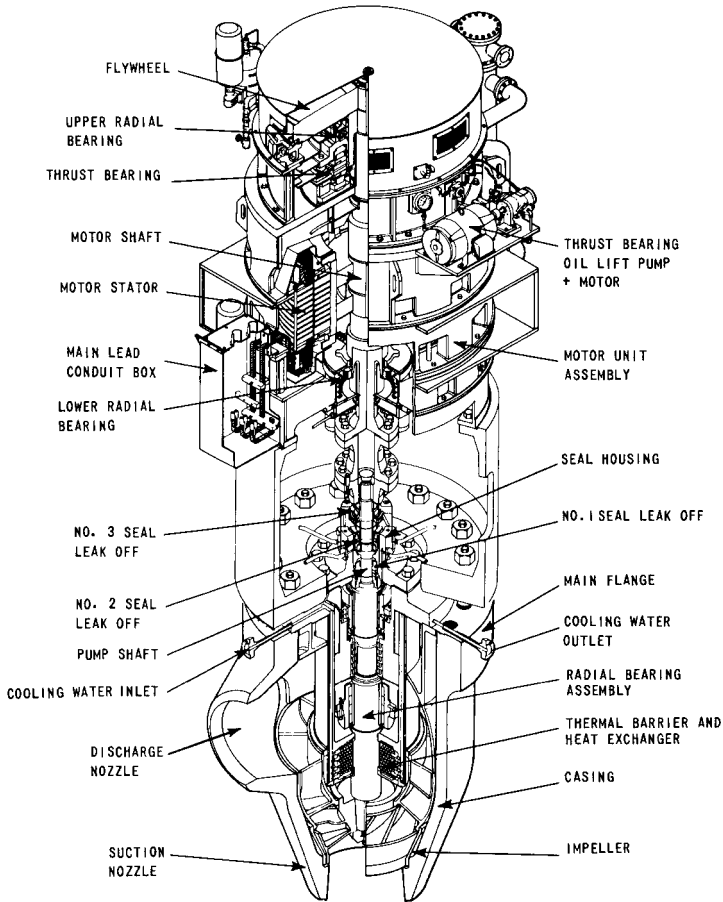


FIGURE 10 Main coolant pump (Westinghouse Electric)

such as state and local jurisdictional bodies. Established rules can be divided into two distinct categories: (1) those controlling integrity of the pressure-retaining boundary and (2) functional considerations.

The hydraulic design of nuclear pumps is the same as that of pumps in conventional service. For recirculation and reactor coolant pumps, a radial discharge is preferred by some users because it tends to simplify certain aspects of the plant design.

Vibration characteristics of pumps in nuclear service are especially important because of the relative inaccessibility of the equipment for checking and servicing and because safety requirements permit only limited outage of pumps; otherwise, the plant must come to standby condition.

An analytical or experimental determination of lateral and torsional natural frequencies is routine for most pump-driver combinations, and occasionally a transient analysis may be required.

**Design under ASME Code Rules** Under the rules established by the ASME Boiler and Pressure Vessel Code, Section III (Nuclear Components), the owner, such as the plant

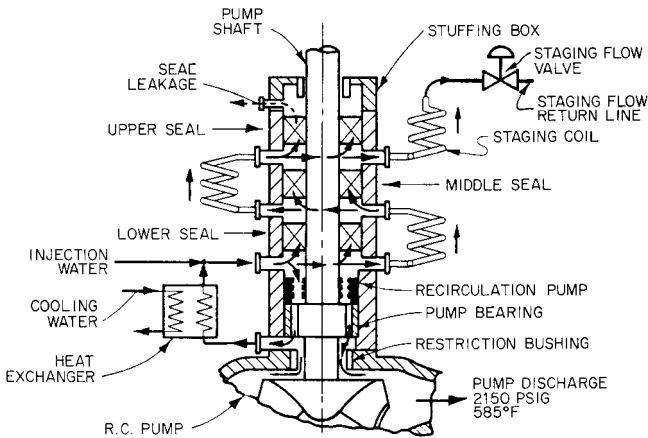


FIGURE 11 Flow schematic for a reactor coolant pump seal (Sulzer Pumps)

designer or public utility, either directly or through an agent, prepares a design specification for a specific pump, which in code terms is a component. This specification must be approved by a licensed Professional Engineer and list the applicable ASME Code Year and Addenda.

The manufacturer builds the pump to the design specification. Verification is provided through the combined efforts of the material supplier, manufacturer, insurance inspector, and state and local enforcement agencies.

The design specification requires compliance with the rules of the code with regard to the design of the pressure boundary and, in addition, includes supplementary requirements prescribed by the owner. Other standards are invoked as applicable to meet the safety and environmental requirements of the U.S. Nuclear Regulatory Commission. Functional needs may be included, and the code class to which the pump is to be built must be identified.

There are three ASME code classes for pumps. For the most critical service, a Class 1 pump is specified. Class 2 represents a pump serving a less critical system, and Class 3 is the lowest-class pump for nuclear service. It is the owner's responsibility to establish the pump class, with guidance provided by the Nuclear Regulatory Commission and the manufacturers.

For the pressure boundary evaluation, a Class 1 pump, by code rules, receives the most detailed analysis using verified and validated modern design techniques. These techniques must be supported, if necessary, by experimental stress analysis, and a certified Design Report must be submitted to the customer to document adherence to the code. Fatigue analysis of critical portions of the pump may be required, and behavior under all plant conditions, including accident, must be evaluated. Class 2 pumps require less analysis, but a certified Design Report is still required, documenting compliance with the customer's specification and the code. For Class 3 pumps, even wider latitude of design is permitted, but a certified Design Report must still be submitted to the customer. All three classes of pumps are to receive an ASME N-stamp by a qualified pump manufacturer upon successful completion of design, manufacture, inspection, test, and document review.

Additionally, nuclear service pumps are usually examined in design for thermal steady-state and transient conditions, behavior under seismic disturbances, conditions of nozzle loadings imposed by system piping, means of support, and accessibility for service, in-service inspection, and replacement.

Rules for quality control during material procurement, manufacture, and test are also contained in the code. Nondestructive examination and document control are detailed, and

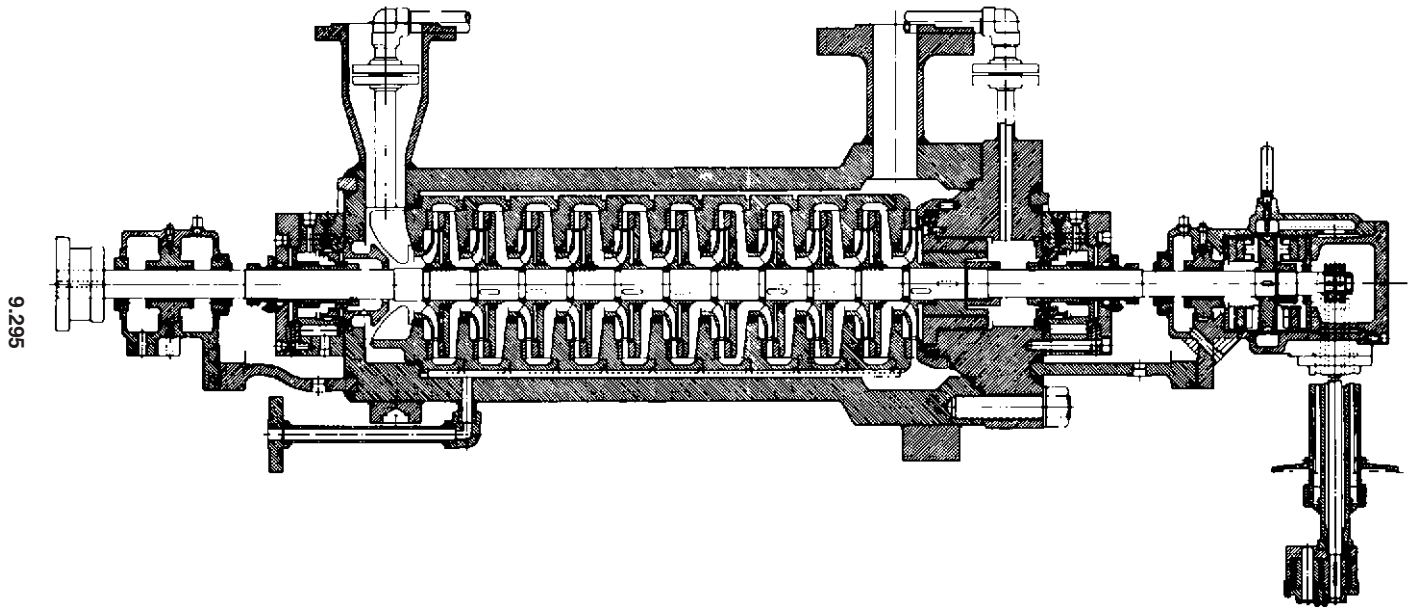


FIGURE 12 Pump for PWR charging and safety injection service (Flowserve Corporation)

9.296

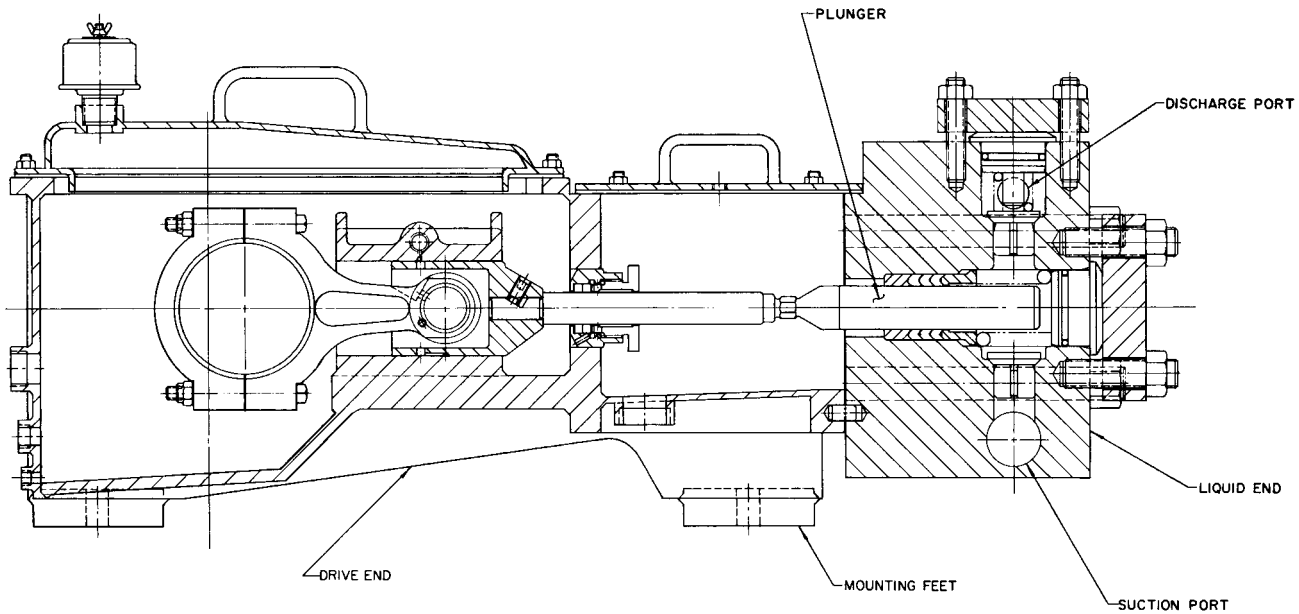


FIGURE 13 Reciprocating pump for nuclear service (Gaulin)



**FIGURE 14** Vertical multiple-stage pump (Flowsolve Corporation)

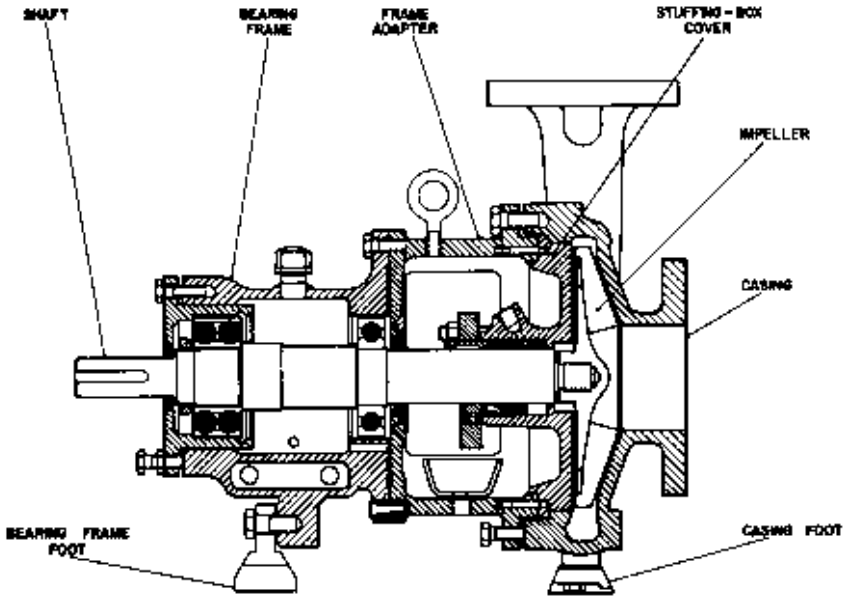


FIGURE 15 Single-stage pump used for many service functions in a nuclear plant (ITT/Gould Pumps, Inc.)

a quality assurance program requiring a formal procedure manual must be prepared and implemented by the manufacturer. Periodic surveys by the ASME verify adherence to code rules. Local jurisdictional authorities provide day-to-day inspection services as required by the manufacturer.

**Design of Noncoded Parts** Parts of the pump that are not classified as pressure boundary items or attachments to the pressure boundary are not covered by the ASME code. The owner's design specification may describe applicable requirements for these non-pressure parts, referencing other documents or excluding use of certain objectionable materials. If the pump is in critical service or is needed in emergency situations, certain ANSI standards may be invoked. Accompanying these rules will be extensive quality assurance and documentation to demonstrate compliance.

## **MATERIALS OF CONSTRUCTION**

**Material Limitations** When pumps built to ASME standards are required, materials for the pressure-retaining parts must be selected from a list approved by the ASME. Section III (Nuclear Components) of the ASME Boiler and Pressure Vessel Code lists these materials, their allowable stresses, and the examination requirements that must be applied to ensure their suitability.

**Typical Materials** Examples of acceptable materials for pressure-retaining boundary parts are shown in Table 3. They are suitable for all three ASME code classes; however,

**TABLE 3** Materials for pressure-retaining boundary parts

Carbon steel	
Castings	SA-216, Gr WCA, WCB, WCC
Forgings	SA-105, Gr I, II
Plate	SA-515, Gr 55, 60, 65, 70
Bolting	SA-193, Gr B6, B7, B8, B16
Stainless steel	
Castings	SA-351, Gr CF8 (304), CF8M (316)
Forgings	SA-182, Gr 304, 316, 321, 347
Plate	SA-240, Gr 304, 316, 321, 347
Nonferrous	
A limited number of nonferrous materials are permitted.	

other acceptable materials may be restricted to use for a particular class. Hazardous and porous materials are generally avoided, as are materials such as cobalt, which, though normally harmless, may become hazardous from radioactive considerations (see following text). Cobalt content is often limited in large stainless steel parts but is usually permitted in concentrated form of small areas, for example, where hard-facing is required.

Materials of construction should not be affected by the usual decontamination chemicals.

Nonpressure boundary parts may be made of conventional materials but will usually require the buyer's approval. Certain elastomers, such as ethylene propylene, which has good radiation stability, are excellent for seal parts. Many fine grades of carbon-graphite are available for water-lubricated bearings and for mechanical seal facings.

### CONSIDERATIONS OF RADIOACTIVITY

Radioactivity may become a serious consideration in the design of nuclear pumps because of the need for servicing the equipment. The water used in the primary system becomes contaminated with metallic elements through solubility, corrosion, and erosion. When circulated through the core region, the metallic elements become radioactive because of interaction with neutrons. These radioactive contaminants may, if soluble, remain in solution in the water or, if insoluble, plate out on metal surfaces or become lodged in "crud traps," such as fit interfaces, screw threads, porous base metals, extremely rough surfaces, cracks, and certain types of weld configurations, such as socket welds. In one case, for instance, a pump impeller returned for overhaul defied attempts at decontamination until it was discovered that a repair had been made to a presumably integral wear ring by undercutting and shrinking on a new ring. The interface was barely perceptible, but once it had been found and the ring had been removed, the impeller was readily decontaminated.

Soluble contaminants are most easily removed by providing the pump with complete drainage features; that is, leaving no internal pockets that are not naturally drainable. Ease and speed of parts replacement are, therefore, also important items of design because they reduce the length of time service personnel are exposed to radiation.

The Nuclear Regulatory Commission (NRC) provides specifications detailing the allowable radiation exposure to personnel. Any pump that produces radioactivity at rates that would exceed these limitations must either be repaired at a facility licensed to handle contaminated material or be decontaminated prior to being sent to a conventional repair shop.

After prolonged service in a nuclear plant, pumps may emit radioactivity at a rate in excess of 2 to 50 rem/hr, far in excess of the NRC limits. Therefore, provisions to decontaminate nuclear pumps becomes an important design characteristic. Although not all nuclear pumps operate in highly radioactive environments, these pumps will usually require some degree of decontamination before they can be freely handled and repaired.

## SEISMIC DESIGN

---

The ASME code requires that a seismic analysis be performed on all classes of nuclear pumps. Refer to Subsection 9.14.2 for more detailed information on this subject.

## TESTING

---

**Hydrostatic Testing** Hydrostatic testing in accordance with ASME code rules is conventional except that specific documentation is required.

**Performance Testing** Performance of nuclear pumps is verified by procedures common to non-nuclear pumps. In addition, however, it may be necessary to demonstrate pump performance under some emergency condition, such as loss of cooling water or seal injection water. Also, a test under simulated total-loss-of-power conditions may be required, in which the reactor coolant pump must coast safely to a stop and withstand loss of both cooling and seal injection water for a finite time.

**Periodic Testing** The ASME code, under its rules for in-service inspection (Section XI), requires periodic testing of certain pumps installed in a nuclear plant. The pumps affected by these rules are those associated with the safety systems and those that may be required to function during an emergency or a reactor shutdown. Examples of such pumps are those for core spray, residual heat removal, boron injection, and containment spray. If pumps cannot be tested in their usual circuit, they must be supplied with bypass loops that can be valved off.

The field testing procedure involves obtaining a baseline set of values for head, flow, speed (if variable), vibration, inlet pressure, and bearing temperatures. The flow quantity that sizes the bypass loop is not specified in the code, but in the practical sense, the flow must be adequate to prevent overheating of the pump and overloading of the bearings. Also, because it is an off-design point, consideration is given to the potential for rough operation due to impeller internal recirculation and possible low-flow cavitation damage. Code rules call for a five-minute running period every three months and longer periods where it is necessary for bearing temperatures to stabilize. If the differences between periodic operating data and baseline data exceed permissible limits, the cause for the differences must be sought and corrected. Record-keeping is therefore a significant part of pump in-service testing.



# 9.14.2 NUCLEAR PUMP SEISMIC QUALIFICATIONS

D. NUTA  
W. E. PARRY, JR.

Nuclear electric generating stations and their components shall be designed to resist the dynamic forces that could result from an earthquake at the site. This subsection covers the seismic qualification requirements for pumps classified according to function and importance based on safe operation and public safety.

## ***SEISMIC CLASSIFICATION OF PUMPS***

---

Pumps that must withstand a safe shutdown earthquake (SSE) and remain functional during and after such an event are designated seismic Category I. Pumps that are not required to remain functional during SSE are designated nonseismic Category I and may be classified as follows:

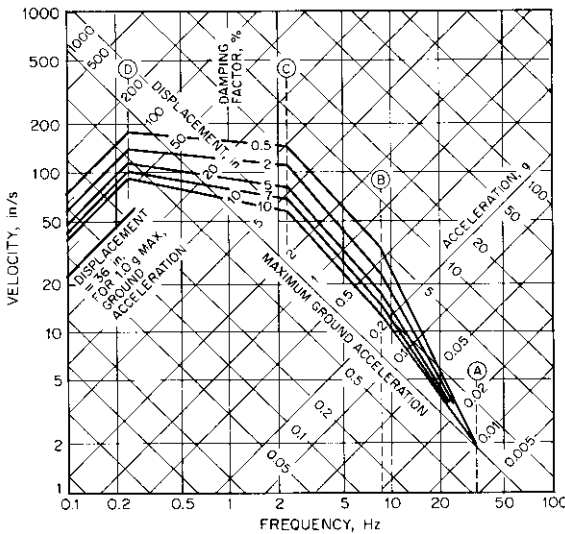
- Nonseismic Category I pumps are located so their failure or structural deformation might keep a seismic Category I piece of equipment or system from performing its intended function. The analysis methods and seismic input used on nonseismic Category I pumps to show that gross failure or excessive deformations will not occur are identical to those used for seismic Category I equipment.
- Nonseismic Category I pumps are located so their failure or structural deformation cannot affect any seismic Category I system or component. Seismic-related requirements for these pumps, if any, are established using a less stringent seismic environment with the aim of minimizing possible replacement expenses following a credible event.

**DEFINITIONS**

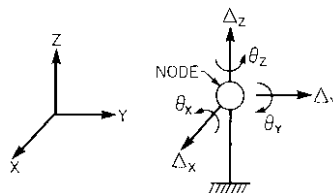
**Critical Damping** This is the minimum damping for which a vibrating system has no vibratory motion. For analysis purposes, damping is expressed as a percentage of critical damping. The amplification of input motion, or magnitude of response, is inversely proportional to the damping ratio of the vibrating system. Figure 1 shows responses obtained for damping ratios which vary from 0.5 to 10% of critical damping.

**Damping** Damping is the dissipation of energy in a vibrating system. Damping is a function of many factors, including material characteristics, stress levels, and geometric configurations and takes place as a result of the transformation of input energy in the form of seismic motion to heat, sound waves, or other energy forms. For analysis purposes, damping is assumed to be viscous; that is, the damping force is proportional to velocity and acts in the opposite direction.

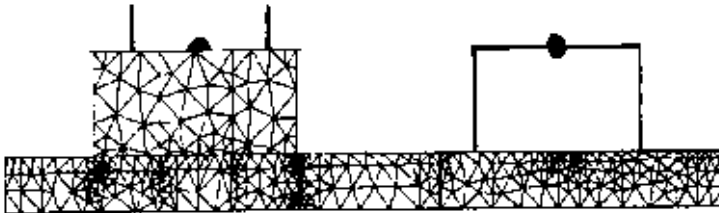
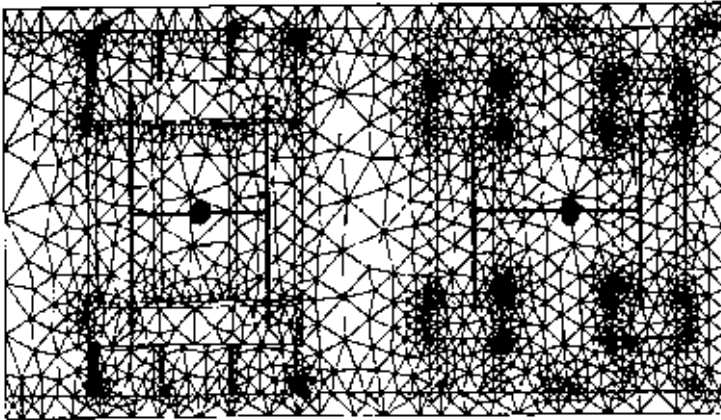
**Degrees of Freedom** The degrees of freedom are the coordinate(s) necessary to adequately describe the behavior of a structure or component. A node, or nodal point, may have as many as six degrees of freedom, consisting of three translations and three rotations (such as  $\Delta_x, \Delta_y, \Delta_z, \theta_x, \theta_y, \theta_z$ , as shown in Figure 2). This complex representation in



**FIGURE 1** Horizontal design response spectra scaled to 1g ground acceleration (1 in = 2.54 cm;  $g = 32.17 \text{ ft/s}^2 = 9.807 \text{ m/s}^2$ )



**FIGURE 2** Nodal degrees of freedom



**FIGURE 3** Typical FEM mesh of Horizontal Pump/Motor Assembly Pump and motor are modeled as lumped-mass elements whereas bedplate is modeled with shell elements.

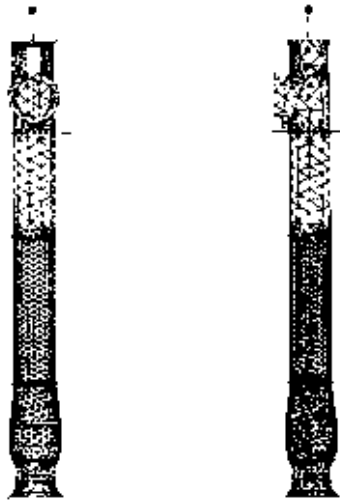
terms of degrees of freedom is used when performing static analysis to obtain forces, stresses, or displacements.

**Finite Element Method** The finite element method of analysis involves the idealization of a structure or component, such as a pump, as an assemblage of elements of finite size. This mathematical model can be a lumped-mass model, a shell element model, a three-dimensional solid model, or a combination of all three. Figures 3 and 4 contain typical shell element models of horizontal and vertical pumps respectively.

**Floor Acceleration** This is the acceleration at a structural floor or any acceleration applicable at the equipment mounting location.

**Ground Acceleration** Ground acceleration is the acceleration of the ground associated with earthquake motion.

**Modal Analysis** Modal analysis is a type of dynamic analysis in which the response of a vibrating system is obtained as a combination of responses of the system's mode shapes. (Specific requirements on the combination of modal responses is contained in U.S. Nuclear



**FIGURE 4** Typical FEM mesh of Vertical Circulating Water Pump. The pump is modeled with shell elements while the motor is modeled with lumped-mass elements.

Regulatory Commission Guide 1.92.) Modal analysis may be used in conjunction with a response spectrum or time history analysis.

**Natural Frequency** The natural frequency is the frequency at which a body vibrates due to its own physical characteristics and to the elastic restoring forces developed when it is displaced in a given direction and then released while restrained or supported at specific points.

**Operating Basis Earthquake (BE)** An operating basis earthquake is an earthquake that could reasonably be expected to affect a plant site during the operating life of the plant. The systems and components necessary for continued operation of a nuclear plant without undue risk to public health and safety are designed to remain functional when subjected to the vibratory ground motion produced by an operating basis earthquake.

**Required Response Spectrum (RRS)** The RRS is the response spectrum for which the equipment (pump assembly) has to be dynamically qualified.

**Response Spectrum** The response spectrum is the plot of the maximum response (acceleration, velocity, displacement) of a series of damped single-degree-of-freedom (SDF) oscillators versus the natural frequencies (or, sometimes, periods) of the oscillators when subjected to the vibratory motion input (time history) at their supports. Figure 5 represents a plot of response spectra obtained for 0, 2, 5, and 10% of critical damping with an earthquake time history as input. The plot is on tripartite log paper, and only a limited number of SDF oscillators are shown (usually, more than 70 are needed to correctly define a spectrum).

In order to facilitate the understanding of how to use the Figure 5 plots, the 0% of critical damping response spectrum is presented in Figure 6. Assuming a SDF oscillator having a frequency of 2 cycles/s (Hz), the maximum displacement of the mass point when subjected to the earthquake record is 7 in (17.8 cm), the maximum velocity is 50 in/s (1.27 m/s), and the maximum acceleration is  $2g$ , where  $g$  = gravitational acceleration =  $32.2 \text{ ft/s}^2$  ( $9.807 \text{ m/s}^2$ ). A line is drawn perpendicular to the frequency axis, and from the intersection of this line with the spectrum curve, a line parallel to the acceleration lines will

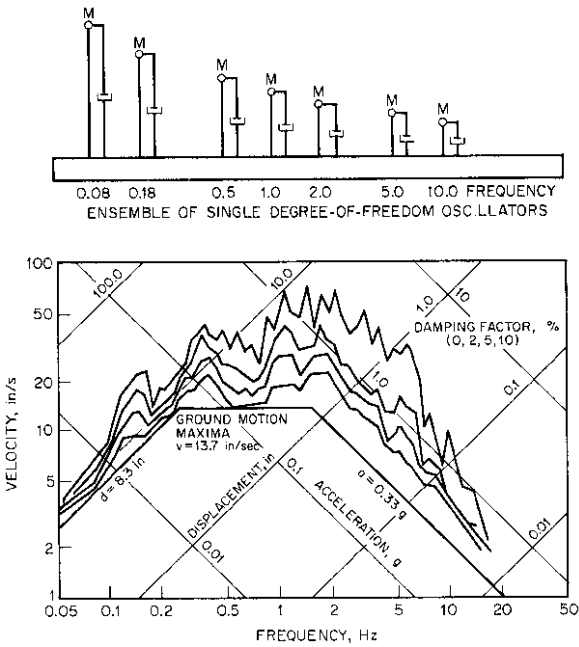


FIGURE 5 Response spectra plots for various dampings (1 in/s = 0.0254 m/s; 1 in = 2.54 cm; 1g = 32.17 ft/s<sup>2</sup> = 9.807 m/s<sup>2</sup>)

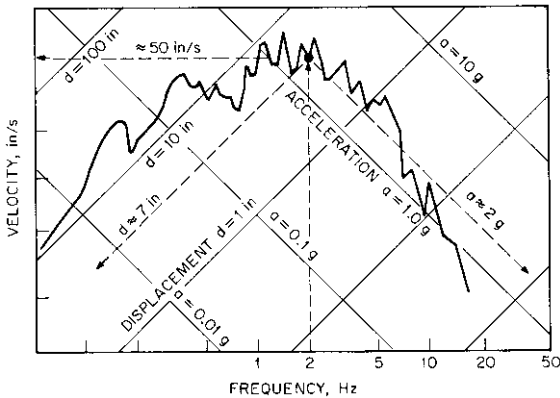


FIGURE 6 Response displacement, velocity, and acceleration versus frequency (1 in/s = 0.0254 m/s; 1 in = 2.54 cm; 1g = 32.17 ft/s<sup>2</sup> = 9.807 m/s<sup>2</sup>)

provide the acceleration  $a \approx 2g$ , a line parallel to the displacement lines will provide the displacement  $d \approx 7$  in (17.8 cm), and a line perpendicular to the velocity axis will provide the velocity  $v \approx 50$  in/s (1.27 m/s).

In general, response spectra are presented as plots of acceleration versus frequency. Given a time history of acceleration, such as the one presented in Figure 7, the response spectrum is obtained as described previously. The response acceleration at frequencies above

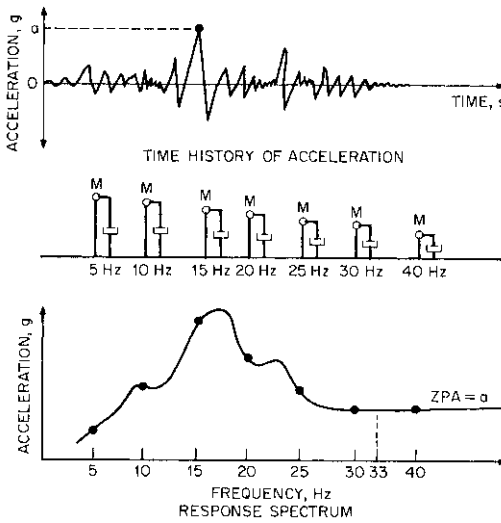


FIGURE 7 Development of acceleration response spectrum ( $1g = 32.17 \text{ ft/s}^2 = 9.807 \text{ m/s}^2$ )

33 Hz (also called zero period acceleration) is equal to the peak acceleration of the time history record regardless of the damping ratio used (the value  $a$  is specified in Figure 7).

**Response Spectrum Analysis** The response spectrum analysis is a modal dynamic analysis that uses response spectra as vibratory input at the pump attachment points.

**Safe Shutdown Earthquake (SSE)** An SSE is an earthquake that produces the maximum vibratory ground motion for which certain structures, systems, and components are designed to remain functional. These structures, systems, and components are those necessary to assure (1) the integrity of the reactor coolant pressure boundary, (2) the capability to shut down the reactor and maintain it in a safe shutdown condition, or (3) the capability to prevent or mitigate the consequences of accidents that could result in potential offsite exposures to radioactive material. Various safety classes are assigned to structures, systems, and components as a function of which of these three categories they belong to.

**Single-Degree-Of-Freedom Oscillator (SDF)** The SDF is a vibrating system consisting of a single node point where the mass is concentrated and supported by a beam and spring element. If the single dynamic degree of freedom is along the axis of the beam, the frequency of the oscillator is

$$f = \frac{1}{2\pi} \sqrt{\frac{K}{M}}$$

where  $f$  = frequency, cycles/s or Hz

$K = EA/L$  = spring stiffness, lb/in (N/mm)

$E$  = Young's modulus of elasticity of support beam, lb/in<sup>2</sup> (Pa)

$A$  = cross-sectional area of support beam, in<sup>2</sup> (mm<sup>2</sup>)

$L$  = length of support beam in (mm)

$M$  = mass lb · s<sup>2</sup>/in (N · s<sup>2</sup>/mm)

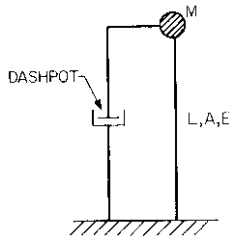


FIGURE 8 Single-degree-of-freedom oscillator

With this idealization, the frequency of the SDF oscillator may be varied by changing the length of the beam element and maintaining  $E$ ,  $A$ , and  $M$  constant (Figure 8). A horizontal degree of freedom would be used in conjunction with beam bending and shearing.

Damping effects are simulated by a dashpot, which can be assigned different damping ratios. Although there is little effect on the frequency of the SDF oscillator when the dashpot is assigned damping ratios below 10 or 15% of critical damping, there is a significant effect when higher values are used. Thus, if the dashpot is assigned 100% of critical damping, the oscillator will behave as a rigid body, duplicating, without amplification, the support input motion.

**Test Response Spectrum (TRS)** The TRS is a response spectrum that is either theoretically constructed or derived using spectrum analysis based on the actual motion of the shake table (during dynamic testing).

**Time History Analysis** The time history analysis is an analysis performed in the time domain using time history vibratory input. A direct integration or modal analysis may be performed.

**Time History of Acceleration** The time history of acceleration is a variation of acceleration as a function of time during the postulated duration of the seismic event.

**Zero Period Acceleration (ZPA)** The ZPA is a response acceleration at frequencies above 33 Hz.

Although these definitions will facilitate the understanding of the seismic considerations discussed herein, the reader is encouraged to review the works listed at the end of this subsection for a more complete list of terms and definitions used in the process of dynamic qualifications.

## SEISMIC QUALIFICATION REQUIREMENTS

The seismic qualification of seismic Category I pumps is performed to demonstrate the ability of the equipment to perform its intended function during and after the time it is subjected to an SSE, which could occur before or after several OBEs. The value of the SSE or OBE response spectra shall be supplied by the equipment buyer (nuclear facility). The simultaneous effects of the seismic accelerations in the two orthogonal horizontal directions and the vertical direction have to be considered.

The seismic qualification can be achieved by

- Analytical methods (static or dynamic analysis)
- Testing the equipment under simulated seismic conditions
- Using a combination of tests and analysis

The information that is provided in the IEEE 344 standard on these qualification methods is applicable to pump assemblies. The information presented hereafter either emphasizes some of the IEEE 344 requirements or is pertinent to pumps and pump assemblies in particular.

**Qualification by Analysis** The initial step in qualifying a pump assembly by analytical methods is to determine the rigidity of the assembly. If the assembly has its lowest natural frequencies greater than the ZPA frequency, typically 33 Hz, the assembly is considered rigid. On the other hand, if one of its natural frequencies falls below the ZPA, the assembly is considered flexible. Therefore, prior to conducting the qualification analysis, the natural frequency of the pump assembly must be determined by either a modal analysis or an equipment “bump” test. The FEM models as shown in Figures 3 and 4 can be used for the modal analysis.

After the rigidity of the pump assembly has been determined, the type of qualification analysis can be selected. The allowable types of analysis are

- **Static analysis** If it can be shown that the equipment is rigid, a static seismic analysis may be performed to determine the stresses and deformations due to the dynamic seismic loads. The dynamic forces shall be determined by multiplying the mass of the assembly times the maximum floor acceleration (ZPA from the response spectra). These forces are then applied through the center of gravity of the assembly. The resulting stresses from each acceleration force are combined by taking the square root of the sum of the squares (SRSS) to yield the total dynamic stress. The dynamic deflections shall be calculated in the same manner.
- **Simplified dynamic analysis** If it has been determined that the equipment is flexible and the customer specification permits, a simplified dynamic analysis may be completed applying the same method as the static analysis but using different values for the dynamic floor accelerations. The applicable floor acceleration shall be obtained by multiplying the acceleration values corresponding to the fundamental natural frequency from the appropriate response spectra curve by 1.5. If the fundamental natural frequency is not known, the maximum peak value of the response spectra shall be multiplied by 1.5. The 1.5 factor will conservatively account for possible participation of higher modes.
- **Detailed dynamic analysis** When justification for a static analysis cannot be provided, a detailed dynamic analysis is required, unless a conservative factor is used to account for the participation of higher modes (simplified dynamic analysis). A mathematical model of the equipment is required to determine the dynamic behavior of the equipment. This mathematical model may be a lumped-mass model, a shell model (see Figure 4), a solid element model, or a combination such as shown in Figure 3. The model should include, when applicable, the hydrodynamic mass that represents the contained water or the effects of submergence on vertical pumps. This model is then analyzed using either response spectra modal analysis or time-history (modal or step-by-step) analysis. The various modal contributions shall be combined by taking the SRSS of the individual modal stress and deformations.

These dynamic analyses are performed with computer programs in the public domain. Such programs include ANSYS, MSC/NASTRAN, ALGOR, and COSMOS/M, which incorporate acceptable methods of combining modal responses, or with a multitude of other finite element programs that are either commercially available or developed specifically for the analysis. Further information regarding specific items related to dynamic analysis, such as damping ratios, combination of modal responses, and modeling techniques may be obtained from the works listed at the end of this subsection. Although recent advancements in computer technology and software have made this type of analysis more readily available, when performing detailed dynamic analyses, a thorough understanding, obtained from experience, is imperative.

After these seismic stresses and deformations have been obtained, they must be combined with the other equipment stresses and deformations, resulting from all of the applicable loads, in order to determine the acceptability of the equipment.



**Qualification by Testing** The equipment is tested by using the applicable seismic information (floor response spectrum or time history). The input test motion should have a TRS that closely envelopes the RRS, and the test should simulate the occurrence of five OBEs followed by one SSE.

Both the pump and the motor are tested under conditions that simulate as closely as possible actual operating conditions and operability. The operability of the pump, which is tested without the piping system attached and in the absence of any fluid, is established by the absence of undue large deflections during testing (which implies low stress levels) and by performance at the end of the test.

The input motion used must have a maximum acceleration equal to or greater than the ZPA and cannot include frequencies above the frequency associated with the ZPA. The input motion is applied to one vertical and one horizontal axis (resultant) simultaneously unless it can be proved that coupling effects are negligible. In general, multiaxis testing using independent random inputs is required.

Unless it has complete symmetry about its vertical axis, the equipment is rotated 90° and retested.

The mounting and support details used during testing should simulate the service mounting as closely as possible and should be designed so the mounting will not cause dynamic coupling to the test assembly or alter the input motion.

**Combination of Test and Analysis** If the motor assembly is tested separately and the pump is qualified by analysis, RRS at the motor assembly attachment points are developed from the pump assembly seismic analysis and used in the motor assembly testing. If both the pump assembly and the motor have to be tested but it is not feasible to test them together, dummy weights are used to replace the assembly part not included in the test and RRS at the location are established and used in testing the missing part.

## **DESIGN AND FUNCTIONAL REQUIREMENTS**

---

The preceding sections provided the procedures for determining the seismic response of pumping equipment. However, in order to determine the acceptability of these results, they have to be combined with the pump's normal operational loads and compared to predetermined stress limitations. In accordance with the ASME code, the customer's design specification shall advise the applicable load combinations and allowable stress values.

Typically, the pump load combinations can be divided into four levels or service limits. Table 1 lists these service limits in ascending order dependent upon the magnitude of component deformation resulting from operation at the prescribed condition. In addition, Table 2 lists the ASME code allowable stress limits for each of these conditions. If no allowable stress limits are specified in the customer's design specification, no allowable stress increases should be used for the increasing load combinations, including those for OBE and SSE operation.

In addition to the specific requirements for stress levels or functionality of pressure containing components, the following items should be addressed as part of any seismic qualification of pump-motor assemblies:

- Secondary stress loading caused by differential movement of connected components should be determined.
- Displacements and deflections should be measured during testing or calculated, if qualified by analysis, in order to assure they are not excessive.
- Loads to be used in the design of the pump-motor assembly foundation and anchorage should be established.
- Seismic loads must be added to other normal shaft loads in order to verify stress levels, bearing loads, running clearances and possibly coupling misalignment.
- For electric motors, deflections or component dislocations should be closely monitored in order to assure that

**TABLE 1** Typical load combinations and stress limits

Plant Condition	Design/ Normal	Upset	Emergency	Faulted
Concurrent Loads	PD + SL	PD + SL + SOT	PD + SL + SOT + OBE	PD + SL + SOT + SSE
Design/Stress Limits	Level A	Level B	Level C	Level D

Where:

PD = Design pressure and temperature

SL = Sustained loads including dead weight and applied nozzle loads

SOT = System operating transients for upset, emergency, and faulted conditions per customer specifications

OBE = Operating basis earthquake

SSE = Safe shutdown earthquake

Level A = Those loadings that the pump may be subjected to in the performance of its specified function

Level B = Those loadings that the pump must withstand without damage requiring repair

Level C = Those loadings that may result in large deformations that necessitate the removal of the pump from service for inspection or repair

Level D = Those loadings that result in gross general deformations with some consequent loss of dimensional stability and damage requiring repair, which may require removal of the unit from service

**TABLE 2** Stress limits

Service limits	Stress limits (maximum normal stress)
Design and Level A	$\sigma_m \leq 1.0S$
	$(\sigma_m \text{ or } \sigma_L) + \sigma_b \leq 1.5S$
Level B	$\sigma_m \leq 1.1S$
	$(z\sigma_m \text{ or } \sigma_L) + \sigma_b \leq 1.65S$
Level C	$\sigma_m \leq 1.5S$
	$(\sigma_m \text{ or } \sigma_L) + \sigma_b \leq 1.8S$
Level D	$\sigma_m \leq 2.0S$
	$(\sigma_m \text{ or } \sigma_L) + \sigma_b \leq 2.4S$

$\sigma_m$  = General membrane stress; equal to average stress across solid section under consideration; excludes discontinuities and concentrations and is produced only by pressure and other mechanical loads

$\sigma_L$  = Local membrane stress; same as  $\sigma_m$  except that  $\sigma_L$  includes effect of discontinuities

$\sigma_b$  = Bending stress; equal to linearly varying portion of stress across solid section under consideration; excludes discontinuities and concentrations and is produced only by mechanical loads

$S$  = Allowable stress, given in Tables I-7.0 and I-8.0 of the ASME code; corresponds to highest metal temperature of section during condition under consideration

SOURCE: ASME Boiler and Pressure Vessel Code, Section III, Nuclear Power Plant Components, Division I, Subsection NC, 1992, New York.

- The rotor will not grind into the stator.
- The fan blades will not damage the winding insulation.
- There is no loss of lubricant and no slipped winding or winding temperature detector.

**DOCUMENTATION**

---

Refer to IEEE 344 for a list of documents that might be required for dynamic qualification of the pump-motor assembly (by test or analysis) and for general guidance in preparing the pump assembly purchase specification.

**FURTHER READING**

---

**U.S. Nuclear Regulatory Commission guides (available from NRC, Washington, D.C.).**

Regulatory Guide 1.100, "Seismic Qualification of Electrical Equipment for Nuclear Power Plants."

Regulatory Guide 1.61, "Damping Values for Seismic Design of Nuclear Power Plants."

Regulatory Guide 1.70, "Standard Format and Content of Safety Analysis Reports of Nuclear Power Plants."

Regulatory Guide 1.89, "Qualification of Class 1E Equipment for Nuclear Power Plants."

Regulatory Guide 1.92, "Combining Modal Responses and Spatial Components in Seismic Response Analysis."

**Industry Standards (Available from the Institute of Electrical and Electronics Engineers, New York.)**

IEEE 323, "Qualifying Class 1E Equipment for Nuclear Power Generating Stations."

IEEE 344, "IEEE Recommended Practices for Seismic Qualification of Class 1E Equipment for Nuclear Power Generating Stations."

**Other Another source that may be helpful comes from the American Society of Civil Engineers.**

American Society of Civil Engineers. "Structural Analysis and Design of Nuclear Plant Facilities." Manuals and Reports on Engineering Practices, No. 58, New York, 1980.

---

# SECTION 9.15

---

# METERING

---

ROBERT H. GLANVILLE  
KEN W. TAYLOR

## **METERING OR PROPORTIONING**

---

Conventional reciprocating pumps can be adapted to function as metering or proportioning devices in the transfer of liquids. The principal adaptation is the addition of a means of varying the pumping rate and predicting what that rate will be, which makes the modified units suitable for use as final control elements in continuous-flow processes. Metering pumps are often employed where two or more liquids must be proportioned or where mixture ratios must be controlled. These effects are achieved by changing the displacement per stroke (by moving the crankpin by special linkages or by partial stroking) or by changing the stroking speed through the use of variable-speed transmissions or electric motors. Accurate cyclic volume compensation can also be performed using electronic calibration.

Four basic types of positive displacement reciprocating pumps, and several variations, are used for this service: packed plunger pumps, pumps with a mechanically actuated diaphragm, pumps with a hydraulically actuated diaphragm, and pumps with hydraulically actuated pistons.

**Packed Plunger** The packed plunger pump is the most commonly used type because of its relatively simple design and wide range of pressure capability. It is an adaptation of the conventional reciprocating transfer pump (Figure 1). Its advantages are

1. Relatively low cost
2. Pressure capability to 50,000 lb/in<sup>2</sup> (345 MPa) gage
3. Mechanical simplicity
4. Wide capacity range, from a few cubic centimeters per hour to 20 gpm (4.5 m<sup>3</sup>/h)
5. High accuracy, better than 1% over a 15:1 range
6. Only slightly affected by changes in discharge pressure

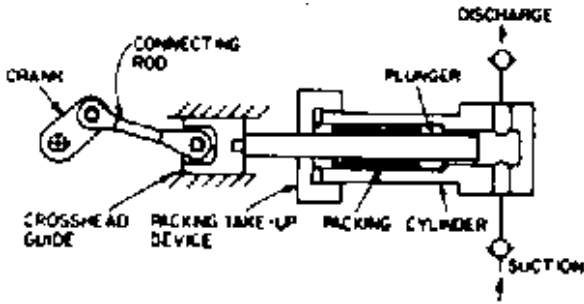


FIGURE 1 Packed plunger pump

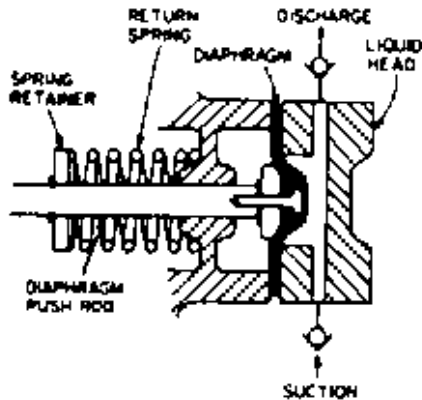


FIGURE 2 Mechanically actuated diaphragm pump

Its disadvantages are

1. Packing leakage, making it unsuitable for corrosive or dangerous chemicals
2. Packing and plunger wear and the resulting need for gland adjustment
3. Inability to pump abrasive slurries or chemicals that crystallize

**Mechanically Actuated Diaphragm** The mechanically actuated diaphragm pump is commonly used for low-pressure service where freedom from leakage is important. This pump utilizes an unsupported diaphragm, which is moved in the discharge direction by a cam and returned by a spring (Figure 2). Its advantages are

1. Relatively low cost
2. Minimum maintenance at 6- to 12-month intervals
3. Zero chemical leakage
4. Ability to pump slurries and corrosive chemicals

Its disadvantages are

1. Discharge pressure limitation of 125 to 150 lb/in<sup>2</sup> (860 to 1030 kPa) gage
2. Accuracy in 5% range and as much as 10% zero shift with change from minimum to maximum discharge pressure
3. Capacity limit of 12 to 15 gph (0.045 to 0.057 m<sup>3</sup>/h)

**Hydraulically Actuated Diaphragm** The hydraulically actuated diaphragm pump is a hybrid design that provides the principal advantages of the other types. A packed plunger is used to pulse hydraulic oil against the back side of the diaphragm. The reciprocating action thus imparted to the diaphragm causes it to pump in the normal manner without being subjected to high pressure differences. A flat diaphragm design is shown in Figure 3 and a tubular diaphragm design in Figure 4.

The advantages of the hydraulically actuated diaphragm pump are

1. Pressure capability to 5000 lb/in<sup>2</sup> (34.5 MPa) gage
2. Capacities to 20 gpm (4.5 m<sup>3</sup>/h)
3. Minimum maintenance
4. Zero chemical leakage
5. Ability to pump slurries and corrosive chemicals
6. Accuracy around 1% over 10:1 range

Its disadvantages are

1. Subject to predictable zero shift of 3 to 5% per 1000 lb/in<sup>2</sup> (6.9 MPa) gage
2. Higher cost

**Hydraulically Actuated Pistons** This type of design is used when high accuracy at relatively low pressure is required. Figure 5 shows the complete pumping and metering unit, whereas Figure 6 shows a sectioned view of the metering unit. The pumping unit shown in Figure 6 can be a gear or vane type, driven by an electric motor. This is integral to a dual-measuring unit (Figure 5), mounted on top of the pumping unit. Alternatively, a centrifugal pump located remotely in the product storage tank can provide the pumping function. The pumping unit is run at a constant speed of about 850 rpm. A bypass valve in the pumping unit varies the output from 0 to 100% in response to a control valve located downstream of the meter.

The metering unit shown in Figure 5 is a dual unit providing two separate measured outputs. Each meter unit has two pistons and three chambers. Scotch yokes that drive a

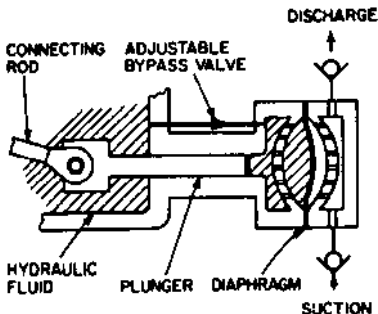


FIGURE 3 Hydraulically actuated diaphragm pump with flat, circular diaphragm

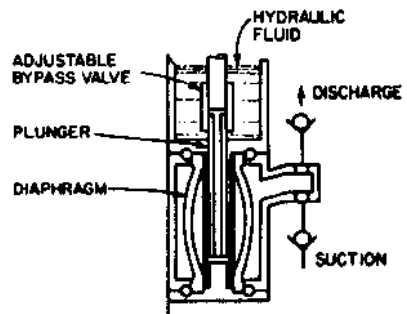


FIGURE 4 Hydraulically actuated diaphragm pump with tubular diaphragm

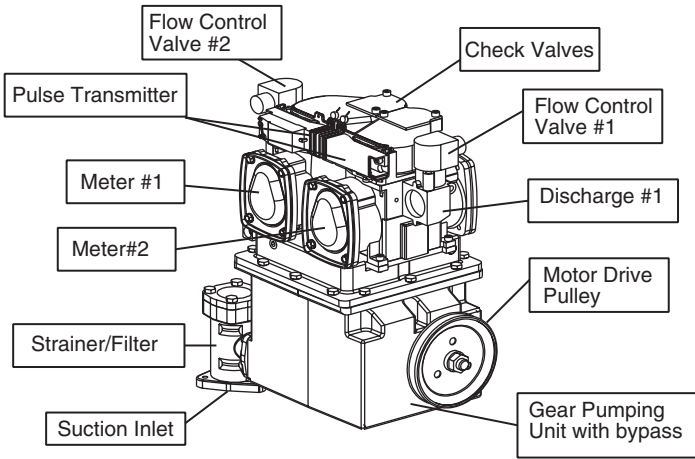


FIGURE 5 "Duplex" metering pump (Dresser-Wayne)

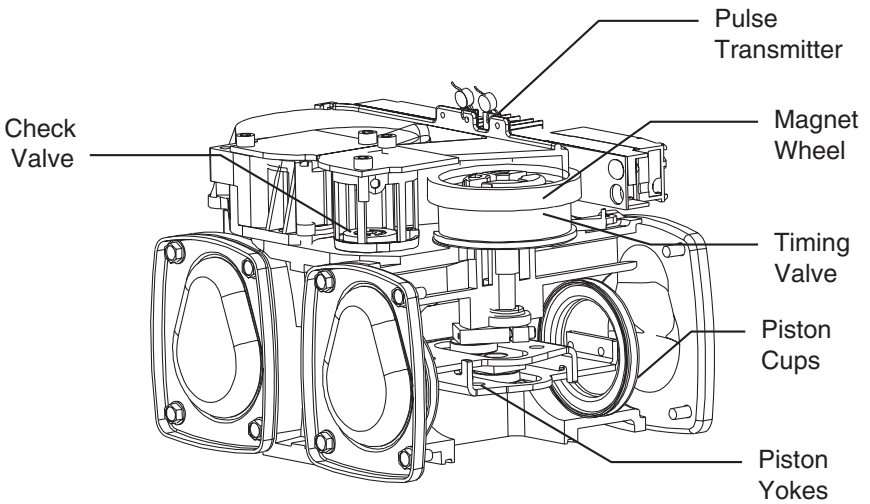


FIGURE 6 "Duplex" meter (Dresser-Wayne)

rotary valve that ports the fluid in and out of the measuring chambers connect the pistons. A shaft encoder and calibration unit is integral to the meter to provide accurate adjustment of the pumped volume together with batch and running volume totals. The advantages are

1. High accuracy (0.25%) across complete flow range to 25 gpm ( $6 \text{ m}^3/\text{h}$ )
2. Compact, totally integrated multi-function design.

3. Minimum maintenance every 1.3–1.5 million gallons (5000–6000 m<sup>3</sup>)
4. Low initial and ownership cost

Its disadvantages are

1. Pressure limitation of 100 lb/in<sup>2</sup> (700 kPa).
2. Maximum flow rate of approximately 25 gpm (6 m<sup>3</sup>/h)
3. Only suitable for low viscosity noncorrosive products.

## CAPACITY CONTROLS

---

There are five methods commonly used to adjust the capacity of metering pumps. The choice of which method to use is determined by the application for which the pump is intended.

**Manually Adjustable While Stopped** This control is generally found on packed plunger pumps of conventional design. Capacity changes are effected by moving the crankpin in or out of the crank arm while the pump is not in motion. This is the least expensive method and is used where frequent changes in pump displacement are not required.

**Manually Adjustable While Running** This feature is most frequently found on mechanically actuated diaphragm pumps, where it is accomplished by limiting the return stroke of the diaphragm with a micrometer screw. On packed plunger pumps, stroke adjustment while the pump is running is relatively complicated. Stroke length is set by some type of adjustable pivot, compound linkage, or tilting plate, which is manually positioned by turning a calibrated screw. On hydraulically actuated diaphragm pumps, relatively simple control is provided by manually adjustable valving that changes the amount of the intermediate liquid bypassed at each stroke.

**Pneumatic** Meeting pumps used in continuous processes must be controlled automatically. In pneumatic systems, the standard 3- to 15-lb/in<sup>2</sup> (21- to 103-kPa) gage air signal is utilized to actuate air cylinders of diaphragms directly connected to the stroke-adjusting mechanism.

**Electric** On electric control systems, stroke adjustment is through electric servos that actuate the mechanical stroke-adjusting mechanism. These accept standard electronic control signals.

**Variable Speed** This method of adjusting capacity is achieved by driving a reciprocating pump with a variable-speed prime mover. Because it is necessary to reduce stroke rate to reduce delivery, discharge pulses are widely spaced when the pump is turning slowly. Surge chambers or holdup tanks are used when this factor is objectionable.

In control situations involving pH and chlorinization, two variables exist at once; for example, flow rate and chemical demand. This is easily handled by a metering pump driven by a variable-speed prime mover. Flow rate can be adjusted by changing the speed of the pump, and chemical demand by changing its displacement.

## CALIBRATION

---

Calibration, which is a fine adjustment of capacity, can be performed in the same way as the capacity controls previously discussed by using a fine stroke adjustment mechanism. It can better be achieved using electronics linked to the pumped volume display. A shaft encoder is connected to the meter that outputs pulses proportional to the volume pumped.



The number of pulses is selected relative to the display resolution required. If  $\frac{1}{100}$  th of a liter were required on a nominal cyclic volume of 1 liter, 105 pulses would be provided per revolution. The pulses are fed into counting and processing electronics. The electronics are put in calibrate mode and a fixed measure pumped into a calibrated vessel. The electronics counts the number of pulses received for the known volume pumped, compares that to the number of pulses it should have received, and calculates a calibration factor for that meter. This factor is stored in nonvolatile memory, and used by counter to "discard" extra pulses when the pump is in normal delivery mode. The 105 pulses per revolution is used to make sure that there are always extra pulses to discard allowing a  $\pm 5\%$  manufacturing variation on the nominal cyclic volume. The calibrating electronics can also store batch and lifetime volumes pumped totals, and supply this information to a local or remote display.

## **SERVICE AND MAINTENANCE**

---

Proportioning pumps utilizing manual capacity controls can be installed, serviced, and operated by plant personnel. Pneumatic capacity controls are more sophisticated, but after their construction and function are understood, maintenance and service should become routine. Electric capacity controls require a basic understanding of electric circuits for installation, operation, and routine service. Modular construction allows repair service by replacement of component groups, thus diminishing the task of trouble-shooting.

All proportioning pumps utilize suction and discharge check valves. These require regular maintenance and service because they are used frequently, encounter corrosion, and must be kept in good working order to ensure accurate pump delivery. Service periods are greatly dependent on liquids pumped, pump operating speed, and daily running time. Usual service periods run from 30 days to 6 months or longer. Check valves are designed to facilitate service with a minimum of downtime, thus allowing replacement of wearing parts at minimum expense. Good design allows this service to be accomplished without breaking pipe connections to the pump.

Packed plunger pumps require periodic adjustments of the packing takeup device to compensate for packing and plunger wear. Packing has to be replaced periodically, and regular lubrication of bearings and wear points is required.

The lubricating oil in speed-reduction gearing, either separate integral units or built in, must be changed at six-month intervals.

Diaphragm pumps usually require replacement of the diaphragm as part of routine service at six-month intervals. On hydraulically actuated diaphragm pumps, the hydraulic fluid must also be changed.

Pneumatic and electric controls generally present no special maintenance problems. The frequency of routine cleaning and lubrication is dependent on environmental conditions and should be consistent with general plant maintenance procedures.

## **INSTALLATION**

---

Proper installation of metering pumps is very important if reliable pump operation is to be obtained.

*NPSH* must be kept as high as possible, and the manufacturer's recommendations as to pipe size and length, strainers, relief valves, and bypasses must be observed.

## **MATERIALS OF CONSTRUCTION**

---

With the tremendous variety of liquid chemicals used in industry today, an all-inclusive guide to suitability of materials for pump construction is virtually impossible. For the great majority of common chemicals, pump manufacturers publish data on materials of

construction. In general, packed plunger and hydraulically actuated diaphragm pumps are available as standard construction in mild steel, cast or ductile iron, stainless steel, and plastic. Mechanically actuated diaphragm pumps are usually available as standard construction in plastic and stainless steel. Almost any combination of materials can be furnished on special order.

Diaphragms are available as standard construction in Teflon, chemically-resistant elastomers, and stainless steel from various manufacturers.

See also Section 3.6, "Diaphragm Pumps," and Section 3.5, "Displacement Pump Flow Control."

---

# SECTION 9.16

---

# SOLIDS PUMPING

---

## 9.16.1

### HYDRAULIC TRANSPORT OF SOLIDS

KENNETH C. WILSON  
ANDERS SELLGREN

---

#### INTRODUCTION

---

**Applications of Slurry Transport** Vast tonnages are pumped every year in the form of solid-liquid mixtures, known as slurries. The majority of applications are short-distance in-plant installations, mainly in the minerals industry. A large plant may contain several hundred centrifugal pumps handling various types of slurries.

The application that involves the largest quantities is the dredging industry, continually maintaining navigation in harbors and rivers, altering coastlines and winning material for landfill and construction purposes. As a single dredge may be required to maintain a throughput of 7000 tons of slurry per hour or more, very large centrifugal pumps are used with impeller diameters of over 100 in. (2.5 m). (See Wilson et al., 1997, and Subsection 9.16.2.)

The manufacture of fertilizer is another process involving massive slurry-transport operations. In Florida phosphate matrix is recovered by huge draglines in open-pit mining operations. It is then slurried, and pumped to the wash plants through pipelines with a typical length of about 6 miles (10 km). The total drive capacity can be in excess of 13,400 hp (10 MW).

Recent decades have seen a great increase in the transport of waste materials, in slurry form, to suitable deposit sites. Waste-disposal environmental problems require that wastes be conveyed to dedicated and monitored disposal sites, either underground or on the surface. This requirement can often be satisfied by backfilling mines (either deep or open-pit), and slurry transport is the favored placing method.

Large slurry pumping operations are found in Alberta, Canada, where oil sands obtained by open-pit mining operations are directly pumped for processing. The mixing and exposure time during the slurry transportation has eliminated some of the processing carried out at the processing plant, resulting in large savings. After the extraction operations are completed, the sand is used as backfill in areas previously mined.

Coarse-particle slurries with maximum particle sizes of 4 inches (100 mm) or more can often be pumped cost-effectively by combining them with smaller particles, to produce a broad and even particle size distribution (Sellgren & Addie, 1998).

Slurry transportation may play an important role in the development of integrated mining systems of tomorrow. In mines there is sometimes a considerable inflow of groundwater that has to be removed. When the mine dewatering installations are integrated with a hydraulic hoisting system, the cost of power needed to pump out the groundwater can be excluded from the cost of hoisting in making cost comparisons with other modes of transporting the solids to the surface. The economic effectiveness of hydraulic hoisting, together with hydraulic design considerations, have been discussed by Kostuik (1965) and Sellgren et al. (1989) for both small shallow mines and large deep underground mines.

Long-distance slurry pipeline transport is a thoroughly tested and cost-effective mode of transportation of ores, coal, and industrial minerals. For example, in Brazil up to 13 million tons (12 million tonnes) of iron ore concentrate (0.15 mm) have been pumped per year since 1977 from an inland mine to a pellet plant at the coast 250 miles (400 km) away. The well-known Black Mesa pipeline in southwestern United States transports a partially processed slurry coal (1.5 mm) about the same distance to an electrical generating station.

Long distance slurry pipelines involve heads of 75 atmospheres or more at each pumping section, the pumps employed are therefore usually of the positive-displacement type (see Subsection 9.16.3). Descriptions of long-distance pipelines and associated slurry pumps can be found, for example, in Brown & Heywood (1991).

**Principles of Slurry Flow** Slurries are mixtures of solid particles and a liquid (typically water). The interaction of the solids and the liquid can produce a large variety of flow behaviors. The major types will be outlined here and described in more detail in subsequent sections. The simplest type of slurry behavior occurs, for example, when silt or fine sand is dredged. It is represented by the “equivalent fluid” model. This evaluates the friction loss (pressure gradient) in the pipeline on the basis of an equivalent fluid with the density of the mixture and a friction factor near that of water at the same flow rate. This simple case is not particularly common in practice. On one hand, there are slurries of finer particles, e.g., natural clays or industrial materials like red mud. Typically, these are non-Newtonian in nature, and require rheological techniques to evaluate the pressure gradient. These will be outlined in the following section on homogeneous slurries.

On the other hand, as particle size or density increases, then settling of particles becomes significant. In turbulent flow the fluctuating velocity of the turbulent eddies ( $v'$ ) acts against the particle settling velocity (terminal fall velocity  $v_t$ ). The importance of particle settling increases as the ratio  $v_t/v'$  becomes larger. When settling is significant the slurry is no longer homogeneous. It is particle-lean near the top of the pipe and particle-rich near the bottom. In the lower area, contact between particles and the bottom of the pipe add a granular (Coulombic) shear stress to that produced by the fluid, thus increasing the pressure gradient (for a given flow rate). The solids contributing to this Coulombic stress are known as “contact load” solids. The stratification ratio, representing the fraction of total solids that travels as contact load, tends to increase with  $v_t/v'$ . The turbulent fluctuating velocity  $v'$  varies with the mean flow velocity  $V_m$  (flow rate divided by  $\pi D^2/4$  where  $D$  is the internal pipe diameter). Thus, decreasing  $V_m$  from an initially large value increases the stratification ratio, and hence the solids effect on the pressure gradient. With further reductions in  $V_m$  the liquid effect on pressure gradient decreases, combining with the increasing solids effect to produce a minimum in the pressure gradient (for constant delivered solids concentration). This minimum, shown schematically on Figure 1, was observed long ago by Blatch (1906).

Calculations for this type of pressure-gradient behavior are outlined in the next section on settling slurries, as are other features of this type of flow. It is worth noting here that, as  $V_m$  is decreased below the minimum-gradient value, there comes a lesser velocity at which particles at the bottom of the pipe cease moving and form a stationary deposit, also shown on Figure 1. This deposit leads to a further increase in pressure gradient (and hence in the power required) and may cause system instability. Beginning with Durand (1951a, 1951b), deposition has been studied extensively (see the settling slurry section), primarily so that it can be predicted and hence avoided in engineering design.

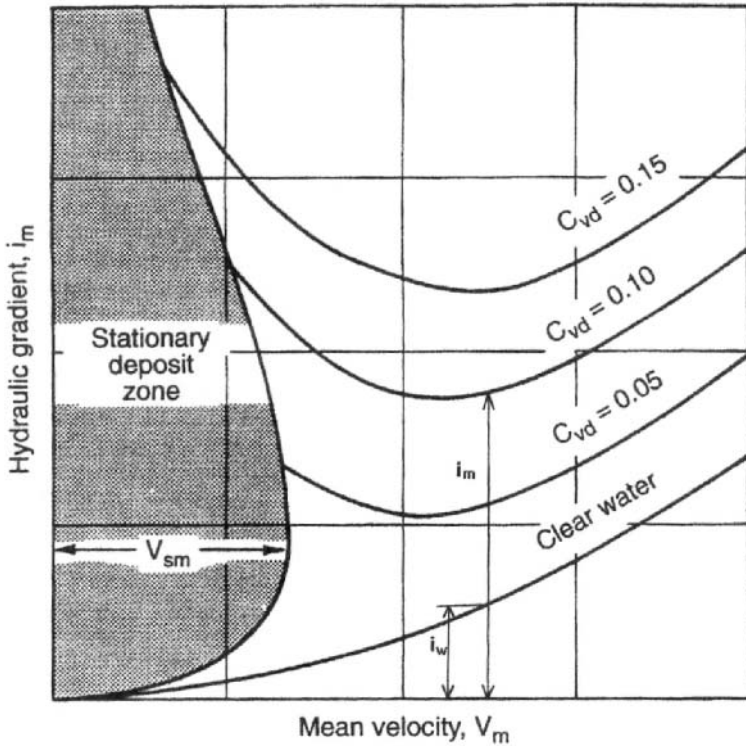


FIGURE 1 Definition sketch

Newitt et al. (1955) divided slurry flows into three types. These include the equivalent-fluid type and the partially stratified type, which have been previously described. The remaining type is known as fully stratified. In this case, either the particle fall velocity is large or the particle size is a significant fraction of the pipe diameter. These factors preclude any support of the solids by the fluid turbulence, so that the submerged weight of all the particles must be carried to the pipe by granular contacts. Calculations (outlined on the section on settling slurries) and experiments show that pressure gradients can be very high for this type of flow. As a result, it is not suitable for long-distance or medium-distance transport; but it has found some applications for short hauls.

## HOMOGENEOUS SLURRIES

**Equivalent-Fluid Calculations** As mentioned in the previous section, pseudo-homogeneous flow (for example aqueous slurries of silt or fine sand) shares with truly homogeneous flow the property that the pressure gradient increases with throughput velocity in a fluid-like fashion. An increase of this type can be expressed, at least to a reasonable approximation, by the statement that the pressure drop for turbulent flow of a homogeneous or pseudo-homogeneous mixture is proportional to that obtained for an equal discharge of carrier fluid alone.

Before this statement can be put into mathematical form, it is necessary to consider various ways of expressing the pressure drop due to friction. The change of pressure per

unit length of pipe,  $\Delta p/\Delta x$ , is not commonly employed in practice, in part because it includes the effect of differences in elevation as well as friction losses. For liquids, especially water, the hydraulic gradient,  $i$ , is normally used. This quantity is the slope of the hydraulic grade line, which is based on the levels to which the fluid would rise in a series of imaginary tubes tapped into the pipeline. As the slope of the hydraulic grade line, the hydraulic gradient represents the drop in level per unit length of pipe. For water (density  $\rho_w$ ) flowing in a horizontal pipe,  $i$  is related to the pressure gradient as follows

$$i = \left( -\frac{\Delta p}{\Delta x} \right) / \rho_w g \quad (1)$$

where  $g$  is gravitational acceleration.

As water forms the carrier liquid in the majority of slurry flows, it is convenient to use it as a standard for comparison of frictional pressure losses. Thus, throughout this chapter the usual expression for frictional losses is in terms of  $i$  (height of water per unit length of pipe). The value for  $i$  for clear-water flow is written  $i_w$ , and that for a mixture (i.e. frictional loss in height of water per unit length) is written  $i_m$ . The statement made previously for homogeneous and pseudo-homogeneous flows amounts to a direct proportionality between  $i_m$  and  $i_w$ .

Calculation of  $i_w$  uses the Stanton-Moody friction factor,  $f$ , in the equation

$$i_w = f \frac{V^2}{2gD} \quad (2)$$

For turbulent flow, the friction factor depends on both the Reynolds number ( $Re = \rho V_m D / \mu$ ) and the relative roughness  $\epsilon/D$ . These two quantities can be entered on Figure 2, which is

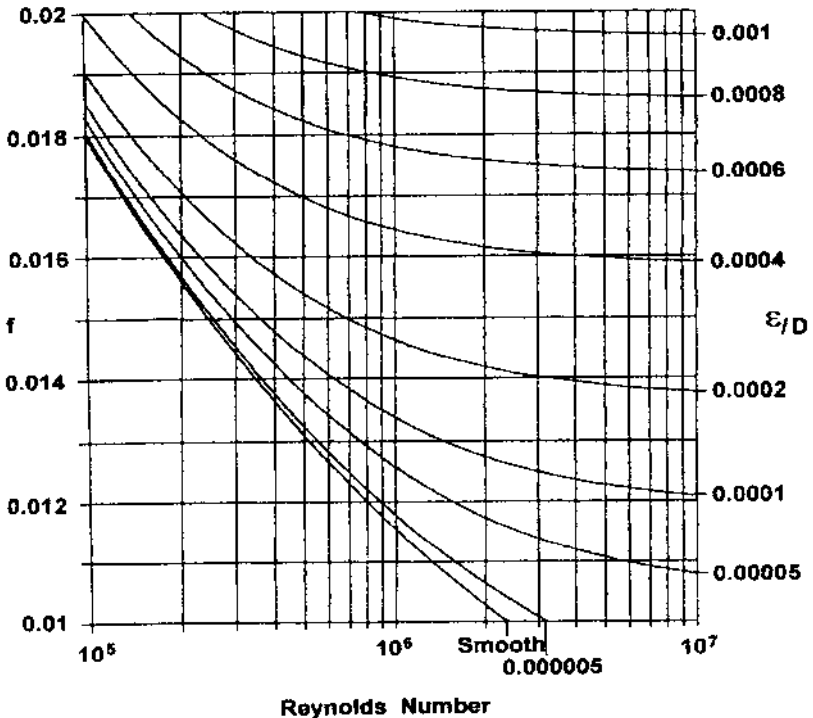


FIGURE 2 Friction factor in normal operating range

used to obtain  $f$ . For example, with  $Re = 1.5 \times 10^6$  and  $\epsilon/D = 0.0001$ ,  $f = 0.013$  (a typical value). As  $f$  is approximately constant for turbulent flow in a given pipe, Eq. 2 shows that the hydraulic gradient varies roughly as  $V^2$  (or as  $Q^2$ ).

In non-slurry applications, if a liquid other than water is conveyed, the hydraulic gradient concept is applied by substituting the density of this liquid for that of water in Eq. 1, so that the hydraulic gradient is expressed in height of flowing liquid per unit length. In considering, say, a pseudo-homogeneous slurry of fine sand, it may be of interest to compare its behavior to that of a liquid with density equal to that of the flowing mixture  $\rho_m$ , which is given by

$$\rho_m = \rho_w(1 + (S_s - 1)C_v) \quad (3)$$

Here  $S_s$  is the relative density of the solids (compared to water) and  $C_v$  is the volumetric concentration of solids.

Substituting  $\rho_m$  for  $\rho_w$  in Eq. 1 gives the mixture-height gradient (i.e. measured in height of mixture rather than of water). For clarity, a different symbol must be used, and  $j$  is employed for this purpose. For a mixture flowing in a horizontal pipe:

$$j = \left( -\frac{\Delta p}{\Delta x} \right) / \rho_m g \quad (4)$$

Although  $j$  is expressed in height of mixture per unit length of pipe, actual measurements based on columns of mixture in vertical tubes would not be feasible, and  $j$  would have to be obtained indirectly from pressure measurements. It can be seen from Eqs. 1 and 4 that the ratio of  $i$  to  $j$  equals the relative density of the mixture  $S_m$  (i.e.  $\rho_m/\rho_w$ ).

The equivalent-fluid model of slurry flow assumes that the solids have little effect on friction factor, and that the mixture acts as a liquid as far as the relative-density effect is concerned. The resulting hydraulic gradient for homogeneous mixture flow,  $i_{mh}$ , is equivalent to the product of  $S_m$  and  $i_w$ . Although the equivalent-fluid model has been widely employed in the past, it is not generally supported by the experimental evidence. For example, sand-water experiments by Carstens & Addie (1981) show that for some pseudo-homogeneous flows  $i_{mh}$  does not exceed  $i_w$  at all. An appropriate equation for the hydraulic gradient is:

$$i_{mh} = [1 + A'(S_m - 1)]i_w \quad (5)$$

Setting the coefficient  $A'$  equal to unity gives the relative-density effect of an equivalent-fluid model, whereas  $A' = 0$  gives the behavior observed by Carstens & Addie (1981). Intermediate types can be represented by values of  $A'$  between zero and unity. Equation 5 will be referred to as the "homogeneous flow" equation, with the specific case of  $A' = 1.0$  called the "equivalent fluid" model.

**Modeling Non-Newtonian Flows** In pipeline transport of non-Newtonian materials, the variation of pressure drop with velocity is typically rather flat for laminar flow, while it is much steeper for turbulent flow. Figure 3 shows these features. This figure is a plot, on logarithmic axes, of hydraulic gradient  $j_m$  (i.e. frictional losses in height of equivalent fluid per unit length of pipe) versus mean velocity  $V_m$  (volumetric discharge/cross-sectional area). The data shown on this plot refer to various concentrations of a red mud tested at the GIW Hydraulic Laboratory in a pipeline with internal diameter of 3.19 in. (81 mm). The plotted data are for mixtures with relative densities from 1.14 to 1.28. Note that where laminar flow occurs the slope of the lines (referred to the logarithmic coordinates) is rather small and does not vary significantly with particle concentration. However, the vertical position of the laminar lines increases strongly with increasing concentration. Conversely, for turbulent flow, concentration has very little effect; all the points fall close to a single line with slope (for logarithmic coordinates) close to 2.0. This behavior implies that the friction factor  $f$  has a near-constant value for the observed turbulent flows. Note that the transitions between laminar and turbulent flow are rather abrupt.

Rheograms, i.e. curves of shear stress versus strain rate, are obtained from tests under laminar conditions, using either rotary viscometers or tube viscometers. The latter are

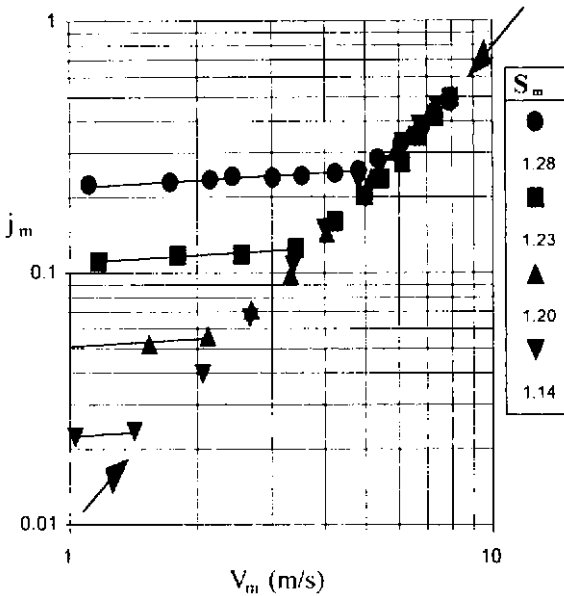


FIGURE 3 Friction gradients of a red-mud slurry

preferable, as they are geometrically similar to the pipeline configuration. For a Newtonian fluid of viscosity  $\mu$ , shear stress  $\tau$  is related to strain rate  $du/dy$  by the classic expression

$$\tau = \mu(du/dy) \quad (6)$$

Rheograms for non-Newtonian materials are not so simple. For example, Figure 4 shows a rheogram for a fine-particle slurry. This rheogram does not pass through the origin (the strain rate remains zero until a certain yield stress  $\tau_y$  is exceeded) and is not straight (although in this case the behavior is approximately linear at large values of strain rate). The definition of viscosity given by Eq. 6 can be retained, although this viscosity no longer represents the slope of the rheogram itself, but rather that of the secant line shown on the figure. Hence  $\mu$  as defined by Eq. 6 can also be called the "secant" viscosity. The tangent to the rheogram, though less meaningful physically, is often referred to. This "tangent" viscosity will be denoted  $\eta_t$ . Both  $\mu$  and  $\eta_t$  vary with position, and hence they both depend on  $du/dy$  (or, alternatively, on  $\tau$ ). The stippling of Figure 4 indicates the area beneath the leftward portion of the rheogram. The area ratio  $\alpha$  (which will be used below) is the ratio between the stippled area and the triangular area below the secant line. As with  $\mu$  and  $\eta_t$ , both the area beneath the rheogram and the area ratio  $\alpha$  depend on  $du/dy$  (or on  $\tau$ ).

It is common practice to represent rheograms by simple mathematical functions (i.e. functions having only two or three parameters). For materials exhibiting a yield stress, the most common engineering choice is the Bingham model, a straight line given by

$$\tau = \tau_B + \eta_B(du/dy) \quad (7)$$

Here the Bingham viscosity  $\eta_B$  is the tangent viscosity given by the slope of the fit line, and the Bingham yield stress  $\tau_B$  is the intercept of the fit line with the shear-stress axis. For the data of Figure 4,  $\tau_B$  is larger than the observed stress at zero strain rate, a situation that is commonly encountered.



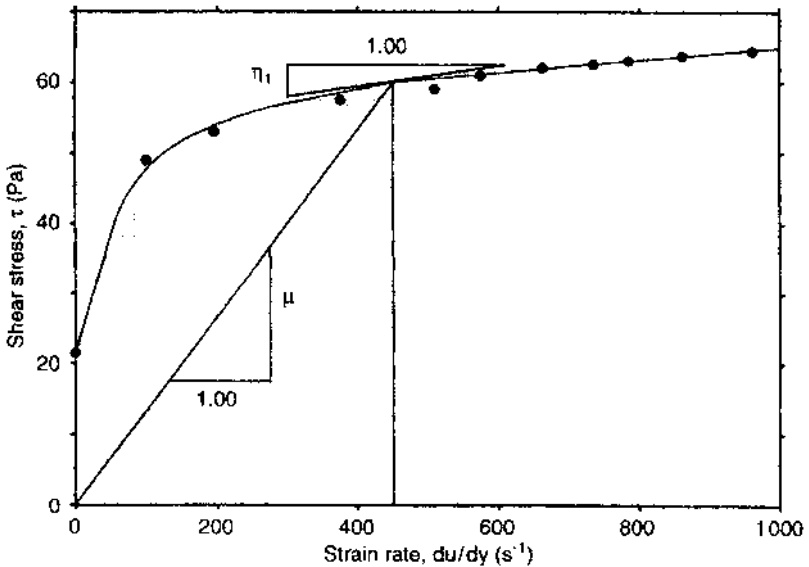


FIGURE 4 Rheogram for phosphate slimes tested at GIW Hydraulic Laboratory (after Wilson, 1986).  
 $[\text{Pa} \times 0.000145 = \text{lb/in}^2]$

The dimensionless ratio  $\tau/\tau_B$  (denoted  $\theta$  and called the stress ratio) is a useful parameter when dealing with Bingham physics. For example, in laminar flow, the secant viscosity ("apparent viscosity")  $\mu$  is related to the stress ratio by the equation

$$\mu/\eta_B = \theta/(\theta - 1) \quad (8)$$

This equation indicates a gradual decrease of  $\mu$  with increasing stress ratio. Another parameter appropriate for Bingham plastics is the Hedström number,  $He$

$$He = D^2 \rho \tau_B / \eta_B^2 \quad (9)$$

where  $\rho$  is the mixture density.

The friction factor for laminar flow of a Bingham plastic can be expressed in terms of these parameters as

$$\sqrt{\frac{8}{f}} = \sqrt{He} \cdot \left( 1 - \frac{4\theta^{-1}}{3} + \frac{\theta^{-4}}{3} \right) \cdot \frac{\sqrt{\theta}}{8} \quad (10)$$

As noted previously, turbulent flows of non-Newtonians are often characterized by a roughly constant value of friction factor, in contrast with the large variations typical of laminar flow. An old way of estimating  $f$  for turbulent flow, proposed by Hedström (1952), is to use the Bingham viscosity  $\eta_B$  in place of  $\mu$  in the relationship for Newtonian turbulent flow. This approach should be considered as only a rough approximation. A better method is to begin with, say, the smooth-wall Newtonian equation

$$V_m = 2.5U_s \ell n(\rho DU_s / \mu) \quad (11)$$

where  $\ell n$  denotes the natural logarithm and the shear velocity  $U_s$ , i.e.  $\sqrt{\tau/\rho}$ , is evaluated at the pipe wall. For turbulent pipe-flow tests of a non-Newtonian material, all quantities except  $\mu$  will be available for each test run. Therefore, in each case Eq. 11 can be solved for

the viscosity, which is now denoted  $\mu_{eq}$ , the equivalent turbulent-flow viscosity. This viscosity is not constant (as would be the case for a Newtonian fluid, or for Hedström's postulate, i.e.  $\mu_{eq} = \eta_B$ ) but varies with wall shear stress, and hence with shear velocity, as described by Wilson et al. (1997).

If turbulent-flow tests are available, scale-up to prototype size can be accomplished directly (as shown in the following section). Otherwise,  $\mu_{eq}$  can be predicted on the basis of the laminar-flow rheogram. The prediction method follows the model of Wilson & Thomas (1985), which in turn is based on a proposal of Lumley (1973, 1978) regarding the viscous sub-layer. Increasing the size of the dissipative micro-eddies leads to an increase in the thickness of this sub-layer. The thickened sub-layer, in turn, produces a higher mean velocity for the same wall shear stress. The model uses the ratio of the integrals under the non-Newtonian and Newtonian rheograms (denoted by  $\alpha$ , and defined earlier in connection with Figure 4) to estimate the size increase of the turbulent micro-eddies. It is found that both the micro-eddy size and the thickness of the viscous sub-layer should be multiplied by a factor equal to  $\alpha$ . This results in a simple expression for the equivalent turbulent-flow viscosity. For a Bingham plastic  $\alpha$  can be expressed in terms of the stress ratio as  $(\theta + 1)/\theta$ , and the expression for  $\mu_{eq}$  becomes

$$\mu_{eq}/\eta_B = [(\theta + 1)/(\theta - 1)]\exp(-4.64/\theta) \quad (12)$$

A plot of this function (Wilson, 1997) shows that, as  $\theta$  increases above 1.0,  $\mu_{eq}/\eta_B$  begins by dropping below unity, descends to a minimum (0.216 at  $\theta = 1.32$ ) and then rises gradually toward unity. The resulting expression for turbulent-flow friction factor depends only on the parameters  $He$  and  $\theta$ . The equivalent expression for laminar flow (Eq. 10) involves the same two parameters. The intercept of turbulent and laminar lines occurs where these two equations give the same value of  $f$ . At this intercept it is possible to eliminate  $\theta$  using an iterative technique, thus producing a plot of  $f$  (at intercept) versus Hedström number. On logarithmic coordinates the plot is not far from a straight line in the region  $200 \leq \sqrt{He} \leq 10000$ , and a power-law approximation can be used in this range, as follows:

$$f \approx 0.0877(He)^{-0.113} \quad (13)$$

Experimental evidence from pipe-flow tests of fine-particle slurries typically shows abrupt laminar-turbulent transitions, followed in the turbulent range by a plateau of virtually constant friction factor. Equation 13 gives a valuable tool for predicting  $f$  for this plateau. This friction factor falls below the traditional curve of Hedström, by which the equivalent turbulent-flow viscosity is equated to the Bingham tangent viscosity,  $\eta_B$ .

This technique can be extended to predict the transition between laminar and turbulent flow. For a Newtonian fluid, with a single rheological parameter ( $\mu$ ), the transition is defined by a specific value of a single dimensionless ratio (the Reynolds number  $\rho V_m D/\mu$ ). A second rheological parameter, required for a non-Newtonian material such as a Bingham plastic, introduces the need for a second dimensionless ratio. In this case the two ratios are the "Bingham" Reynolds number, i.e.  $Re_B = \rho V_m D/\eta_B$  and Hedström number which has been previously defined. As pointed out by D. G. Thomas (1963) the laminar-turbulent transition must now be defined by a functional relationship linking  $Re_B$  at transition with  $He$ .

Following the method used in obtaining Eq. 13, the laminar and turbulent relations can be equated at the intercept and  $f$  (as well as  $\theta$ ) can be eliminated to obtain a plot of  $Re_B$  at intercept versus  $He$ . It was found that the result could be closely approximated by the simple relationship that  $Re_B$  equals  $25\sqrt{He}$ . On cancelling common quantities, it is seen that the flow velocity at transition, say  $V_T$ , is given by:

$$V_T \approx 25\sqrt{\tau_B/\rho} \quad (14)$$

The approach of D. G. Thomas (1963) produced a similar form in the limit, but with a coefficient of 19 rather than 25.

**Scale-up of Laminar and Turbulent Flows** The laminar flow of any given fluid can be scaled from one pipe size to another by use of the Rabinowitsch-Mooney technique provided that the flow remains laminar in both pipes (turbulent flow will be dealt with separately below). The basis of the Rabinowitsch-Mooney technique is the plot of wall shear stress  $\tau_0$  versus  $8V_m/D$ . Rabinowitsch (1929) and Mooney (1931) proved that for steady uniform laminar flows in a pipe  $\tau_0$  and  $8V_m/D$  are linked in a functional relationship. In other words, for a given material the values of both  $\tau_0$  and  $8V_m/D$  can be determined from experiments in a single pipe. The experimentally determined plot or function linking these two variables can then be applied to all laminar flows of the material in question, whatever the pipe diameter.

The application of the method is based on a logarithmic plot of  $\tau_0$  versus  $8V_m/D$  obtained from a pipe of internal diameter  $D_1$ . For some other pipe, of diameter  $D_2$ , the pressure gradient  $dp/dx$  can be obtained from the plotted values of  $\tau_0$  by multiplying them by  $(4/D_2)$ . Since the factors by which each of the coordinates are multiplied depend only on  $D_2$ , a simple re-scaling of the axes of the figure based on  $D_1$  gives a plot of  $dp/dx$  versus  $V_m$  for a pipe of diameter  $D_2$ . For plots on logarithmic coordinates, this type of scaling amounts to a pair of linear translations, which do not affect the shape of the plot. In this regard it should be noted that a Newtonian fluid shows a slope of unity on a logarithmic plot of pressure gradient versus mean velocity, whereas the slopes of logarithmic plots for non-Newtonian laminar flow (such as those on Figure 3) are much flatter.

An alternative way of dealing with scale-up to a larger pipe is to transform the data from the experimental pipe (diameter  $D_1$ ) to the prototype (diameter  $D_2$ ) on a point-by-point basis. This process is similar to using the affinity laws for scaling head and discharge data for a centrifugal pump. For the pipe, the analogous quantities are the frictional gradient  $i_m$  (ft of water/ft or m of water/m) and the mean velocity  $V_m$ . With the subscripts 1 and 2 denoting experimental and prototype conditions, respectively, the scaling relations (affinity laws) for laminar flows in pipes are:

$$(i_m)_2 = (i_m)_1 \left( \frac{D_1}{D_2} \right) \quad (15)$$

and

$$(V_m)_2 = (V_m)_1 \left( \frac{D_2}{D_1} \right) \quad (16)$$

If it is foreseen that flow in the prototype pipeline may be turbulent, it is important to extend the small-scale experimental tests into the turbulent-flow region, and then to scale these test results up to prototype size. For turbulent scaling, as for the laminar case, the quantity that remains unchanged is the wall shear stress  $\tau_0$ . As in laminar flow, the wall shear stress fully determines the stress distribution within the pipe. For example, with a material having a yield stress  $\tau_y$ , a specified value of  $\tau_0$  is sufficient to give the fraction of the pipe area where  $\tau < \tau_y$ , a factor which can affect the mean velocity (Wilson & Thomas, 1985; Thomas & Wilson, 1987). Likewise, a given value of  $\tau_0$ , and hence of  $U_s$ , determines conditions within the viscous sub-layer and hence establishes both  $\mu$  and the area ratio  $\alpha$ . The result is that  $\tau_0$  (or  $U_s$ ) is sufficient to determine the equivalent turbulent-flow viscosity. For each value of  $\tau_0$  two scaling laws apply to turbulent pipe flow. The first, for pressure gradient, is the same as that established for laminar flow, i.e. Eq. 15. The second scaling law, for mean velocity, is given by

$$(V_m)_2 = (V_m)_1 + 2.5U_s \ell n(D_2/D_1) \quad (17)$$

As with Eqs. 15 and 16 for laminar flow, the combined use of Eqs. 15 and 17 allow scale-up of data for turbulent non-Newtonian flow from one pipe size to another. Wilson (1986) gives an example where scaled-up values from a small pipe are compared to measured data in a larger pipe, with very satisfactory agreement. Equation 17 is also valid for cases where  $\mu$  is constant, i.e. for Newtonian fluids, and for turbulent flow of dilute polymer solutions exhibiting drag reduction (Wilson, 1989).

**TABLE 1** Data for phosphate slimes slurry in 8 in. (203 mm) pipe

Run	$V_m$		$8V_m/D(s^{-1})$	$i_m$	$\tau_0$		$U_*$	
	ft/s	m/s			lb/ft <sup>2</sup>	Pa	ft/s	m/s
1	1.7	0.53	21.0	0.1004	1.04	49.9	0.69	0.210
2	5.0	1.52	60.1	0.1130	1.17	56.2	0.73	0.223
3	6.6	2.00	78.8	0.1150	1.19	57.2	0.74	0.225
4	8.5	2.59	102.1	0.1189	1.24	59.1	0.75	0.229
5	10.6	3.24	127.9	0.1218	1.27	60.1	0.76	0.231
6	12.5	3.81	150.3	0.1237	1.29	61.5	0.77	0.233
7	14.5	4.43	174.7	0.1273	1.32	63.4	0.78	0.237
8	16.8	5.12	202.0	0.1348	1.40	67.0	0.80	0.243
9	18.5	5.64	222.6	0.1472	1.53	73.2	0.83	0.254

**EXAMPLE 1** A clay-water slurry of phosphate slimes is to be pumped over a horizontal distance of 2300 ft. (700 m), using a pipe of internal diameter 12 in. (305 mm). The slurry will be taken from a pond in which the relative density of the mixture is 1.13. Tests have been carried out with this material using a pipe of internal diameter 8 in. (203 mm). Test data for  $i_m$  and  $V_m$  appear in Table 1 together with values of  $8V_m/D$  and  $\tau_0$  (the wall shear stress equals  $\rho_w g i_m D/4$ ). Figure 5 shows the values of  $i_m$  plotted versus  $V_m$  for the test pipe.

The preliminary design of the pumping system calls for a discharge  $Q_m$  of 4770 gpm (0.30 m<sup>3</sup>/s) in the prototype pipe. However, this value is not yet definite, and  $Q_m$  values of 3180 gpm (0.20 m<sup>3</sup>/s) and 6360 gpm (0.40 m<sup>3</sup>/s) are also to be considered.

- a.** Find the values of  $i_m$  for the three values of  $Q_m$  just noted. First, the pipe area (0.785 ft<sup>2</sup> or 0.0731 m<sup>2</sup>) is used to obtain the required velocities, i.e. 9.0, 13.5 and 18.0 ft/s (2.74, 4.11 and 5.48 m/s).

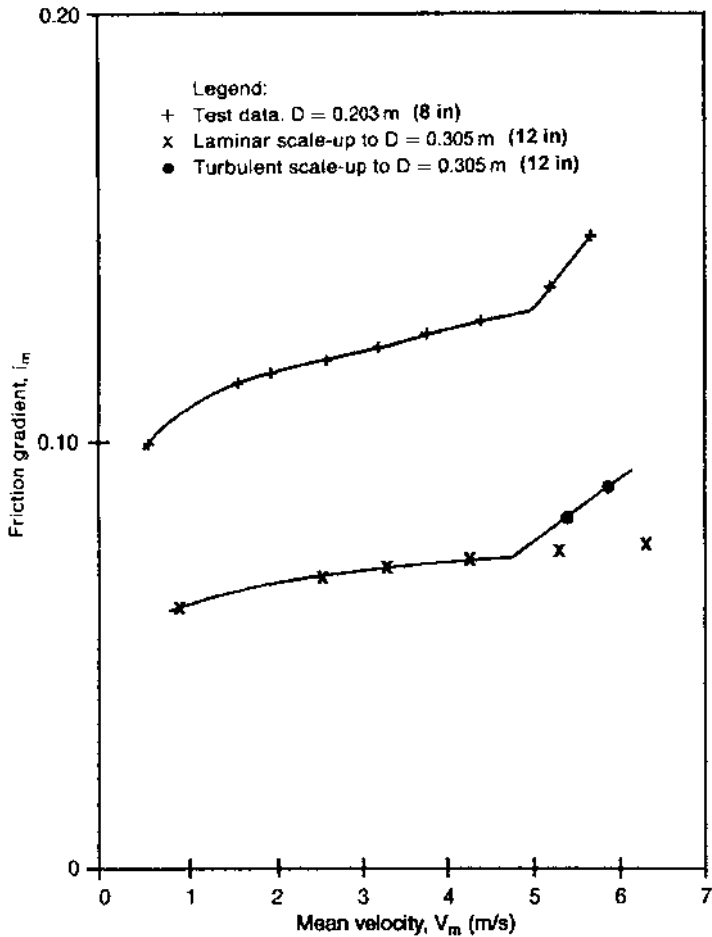
The next step is to scale the data points from the test pipe to the prototype pipe. For the laminar-flow points the appropriate scaling laws are given by Eqs. 15 and 16, which show that  $i_m$  scales inversely with the diameter ratio while  $V_m$  scales directly with this ratio. Points from test runs 1 to 7 have been scaled on this basis and the first six are shown on Figure 5. For test runs 8 and 9 the flow is turbulent. The hydraulic gradient can still be scaled by Eq. 15, but  $V_m$  must now be scaled by Eq. 17. This requires evaluation of  $U_*$ , i.e.  $\sqrt{\tau_0/\rho}$ . For example, run 8 with  $\tau_0 = 0.01$  lb/ft<sup>2</sup> (67.0 Pa) has  $U_* = 0.8$  ft/s (0.243 m/s), for which Eq. 17 gives a scaled-up value of  $V_m$  equal to 17.6 ft/s (5.37 m/s).

The laminar-turbulent transition point is obtained by projecting the turbulent line back to intercept the laminar line. For the data in the test pipe this intercept occurred to the right of point 7, at a velocity of about 16 ft/s (say 5 m/s). For the prototype pipe the intercept lies between points 4 and 5, with a slightly lower velocity. Note that the scaled values for points 5 to 7 are not physically meaningful, because the equivalent flows in the prototype pipe are turbulent, not laminar.

Figure 5 shows that conditions will be laminar for the two lower flows to be investigated, and turbulent for the highest flow. The values of  $i_m$  can be taken directly from the figure, and are listed in Table 2.

The flat curve for laminar flow, plotted on Figure 5, shows a very small rise in  $i_m$  as  $Q_m$  goes from 7.1 to 10.6 ft<sup>3</sup>/s (0.20 to 0.30 m<sup>3</sup>/s). On the other hand, the equal increase of  $Q_m$  from 10.6 to 14.1 ft<sup>3</sup>/s (0.30 to 0.40 m<sup>3</sup>/s) requires a much larger increment in  $i_m$ , as a result of the shift from laminar to turbulent flow.

- b.** Suppose now that testing had stopped after run 6, so that no turbulent-data flow points were available.

FIGURE 5 Test data and scale-up for Example 1. [ $\text{m/s} \times 3.28 = \text{ft/s}$ ]**TABLE 2** Hydraulic gradients and pump heads from scaled-up values

$Q_m$ ( $\text{m}^3/\text{s}$ )	0.20	0.30	0.40
$Q_m$ (US gpm)	3180	4760	6360
$V_m$ (m/s)	2.74	4.11	5.48
$V_m$ (ft/s)	9.0	13.5	18.0
$i_m$	0.0760	0.0795	0.0915
Pump Head (m water)	53.2	55.6	64.0
Pump Head (ft water)	174	183	210

In this case the laminar line would be scaled as before, but the transition to turbulent flow must be predicted from the parameters of the laminar-flow rheogram. It was found that all laminar points except the lowest one can be considered as

obeying a Bingham formulation of the rheogram, with  $\tau_y = 0.0076 \text{ lb/in}^2$  (52.7 Pa) and  $\eta_B = 0.020 \text{ Pa} \cdot \text{s}$ . Substitution of these quantities into Eq. 14 yields  $V_T = 17.7 \text{ ft/s}$  (5.4 m/s) which is somewhat above the observed transition. The similar expression of D. G. Thomas (1963) gives  $V_T$  of 13.4 ft/s (4.1 m/s), significantly below the observed transition point. The use of Eq. 13 to evaluate turbulent friction produces a turbulent line that passes through the transition point predicted by Eq. 14.

## SETTLING SLURRIES

**Velocity at Limit of Stationary Deposition** The deposition limit will be discussed in this section, and the modelling of fully-stratified coarse-particle flow at velocities above the deposition limit in the following section.

The results of a detailed force-balance computer model for the limit of stationary deposition showed that the throughput velocity  $V_m$  at this limit is concentration-dependent, having small values at low concentration, rising to a maximum (denoted  $V_{sm}$ ) at some intermediate concentration (which depends on pipe size and particle size and density) and then dropping off again as the delivered solids concentration approaches the loose-poured value,  $C_{vb}$ . This behavior was shown on Figure 1. It should be noted that the velocities used here are obtained simply by dividing the mixture flow rate ( $Q_m$ ) by the pipe area ( $\pi D^2/4$ ).

The computer output is unwieldy for a designer concerned with many alternative proposals. Moreover, the conservative designer may be content to know only the maximum velocity at the limit of deposition,  $V_{sm}$ , since maintaining the operating velocity above this value ensures that deposition will not occur. The value of  $V_{sm}$  depends on internal pipe diameter, particle diameter and relative density, and the effect of these variables is expressed concisely by a nomographic chart which was developed at Queen's University (Wilson & Judge, 1978; Wilson, 1979) with the help of the late Professor F. M. Wood's expertise in nomography (Wood, 1935). This chart, reproduced here as Figure 6, is recommended as a practical design aid.

It should be noted, by way of explanation of the chart, that the left-hand panel deals with sand-weight materials ( $S_s = 2.65$ ). The internal pipe diameter appears on the left vertical axis, with  $V_{sm}$  on the central vertical axis. The particle diameter is plotted on a curve known, on the basis of its shape, as the "demi McDonald." This shape illustrates that for large particles, but not for small ones, the shear stress at the interface between the upper and lower layers increases with increasing particle size. Thus, for coarse-particle transport the velocity at the limit of deposition (i.e. the velocity beyond which no bed can remain stationary) will decrease with increasing particle size. This finding, which is amply supported by experimental evidence, shows how the fully-stratified mode of transport can display behavior quite different from that of the heterogeneous mode.

To demonstrate the particle size effect consider particles of  $S_s = 2.65$  in a pipe 12 inches (0.30 m) in diameter. This diameter is located on the vertical scale on the left-hand side of the chart, and connected by straight-edge to any desired particle size on the curved scale.  $V_{sm}$  is then obtained by projected to the central vertical scale. For instance, a particle size of 0.025 in. (0.6 mm) gives  $V_{sm}$  of almost 13 ft/s (4 m/s), which is the largest value found for this pipe diameter and solids density. For a larger particle of, say 0.2 in. (5 mm), the deposition-limit velocity is diminished to about 9 ft/s (2.7 m/s).

When operating with centrifugal pumps it may be difficult to take advantage of the decrease of  $V_{sm}$  with increasing particle size. The question is one of obtaining a stable intercept of pump and pipeline characteristics, and will be discussed later in this section. For applications where control of particle size is limited, the conservative designer may wish simply to assume particles of "Murphian" size, i.e. those which give the largest value of  $V_{sm}$  for the pipe under consideration. In this case, it should be noted that the values of  $V_{sm}$  obtained from Figure 6 tend to be conservatively high, especially for large pipe diameters. Thus, these values can sometimes be used as operating velocities.

A particularly useful feature of nomographic presentation of results is that it gives an immediate indication of the sensitivity of the output to variations in the input. Thus on Figure 6 it is seen that the value of  $V_{sm}$  for sandweight solids in a 12 in. (0.30 m) pipe is

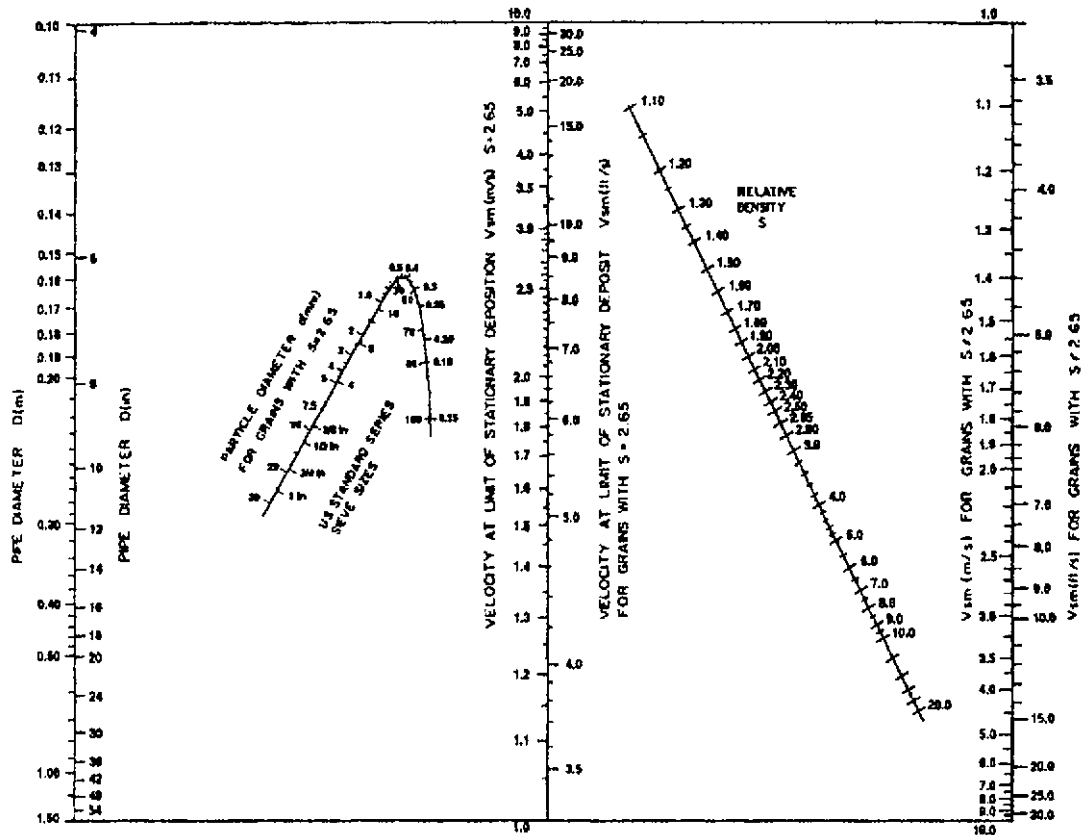


FIGURE 6 Nomographic chart for maximum velocity at limit of stationary deposition (from Wilson, 1979).

virtually unaffected by a variation of the particle diameter between 0.015 and 0.04 in. (0.4 and 1.0 mm). However, the right limb of the particle-diameter curve shows greatly increased sensitivity, so that a change in  $d$  from 0.006 to 0.008 in. (0.15 to 0.20 mm) alters  $V_{sm}$  by more than 25 percent.

It is found that a change of the relative density does not influence the form of the relation shown on Figure 6, but does require its "recalibration." This is accomplished graphically by using the inclined relative-density axis on the right-hand side of the figure. To illustrate the use of the right-hand panel of Figure 6, consider again the pipe 12 inches (0.30 m) in diameter, now carrying particles with a diameter of 0.004 in. (1.0 mm) and relative density 1.50. With 0.004 in. (1.0 mm) entered on the particle scale, a straight line joining it to the pipe diameter can be projected to the central axis of the figure, showing that  $V_{sm}$  is 11.5 ft/s (3.5 m/s) for the equivalent sand size. In order to correct this for the relative density of 1.50, the latter value is entered on the sloping axis on the right-hand side of the figure and joined by straight-edge to the point just found on the central axis (11.5 ft/s or 3.5 m/s). The projection of this line to the vertical axis on the right of the figure gives the adjusted value of the maximum deposition velocity, approximately 6 ft/s (1.9 m/s).

Particles that differ in density from sands may also have different values of other properties, including the solids fraction in the deposit and the mechanical friction coefficient between the particles and the pipe. The values of these quantities that were employed in the computer program, and hence are reflected in the nomographic chart, apply to sands but not necessarily to other materials. Therefore the values of  $V_{sm}$  determined from Figure 6 for materials other than sands must be treated as somewhat less accurate than values for sand. However, both the solids fraction in the bed and the particle-pipe mechanical friction coefficient occur in the computer program only as multiples of the submerged relative density of the particles, and it is found that any change in these quantities merely gives rise to a multiplicative factor which must be applied to the values of  $V_{sm}$  obtained from the figure. This permits calibration of the output of the nomographic chart from a few pilot-plant tests with the material of interest.

The particle diameter scale of Figure 6 has not been extended below 0.006 in. (0.15 mm) since smaller particles tend to be influenced by mechanisms not included in the mathematical model on which the nomogram is based. As shown by Thomas (1979) the viscous sublayer can have a significant effect, and all particles which are small enough to be completely embedded in this sublayer will behave in a fashion which is no longer dependent on particle diameter. In this limiting case certain simplifications can be made in the mathematical model. Thomas found that these lead to a simple expression for the shear velocity at the limit of stationary deposition, and on employing a power law approximation for the friction factor, he then obtained a corresponding expression for  $V_{sm}$

$$V_{sm} = 9.0[g\nu(S_s - S_f)]^{0.37}(D/\nu)^{0.11} \quad (18)$$

Here  $\nu$  represents the kinematic viscosity of the carrier fluid (i.e.  $\mu/\rho$ ), and the coefficient of 9.0 applies in any consistent system of units. This equation gives the minimum value of deposition velocity for small particles, assuming turbulent flow.

For cases where the interfacial friction sets up a sheared layer several grain diameters in thickness, a new analysis has been developed (Wilson, 1988; Wilson & Nnadi, 1990). For large pipes, and particles near the Murphian size, this new analysis shows that the particle size no longer influences  $V_{sm}$  directly. In such cases the value of  $V_{sm}$  is less than that predicted by Figure 6, a point which is in accord with experimental evidence. It is then necessary to obtain the value of  $V_{sm}$  from the new analysis of Interfacial friction, for comparison with the value from the nomographic chart.

When the parameters in the new analysis are given values typical for sands, it is found that the dimensionless maximum deposition velocity (i.e. the Durand deposition variable) depends only on the fluid friction factor for the portion of the pipe wall above the deposit. A power-law approximation gives an appropriate fit function for this effect, i.e.

$$\frac{(V_{sm})_{\max}}{\sqrt{2gD(S_s - S_f)}} = \left( \frac{0.018}{f_f} \right)^{0.13} \quad (19)$$



where  $f_f$  is the friction factor for fluid alone. If the value of  $V_{sm}$  found from the nomographic chart exceeds the value of  $(V_{sm})_{max}$  from Eq. 19 the latter value should be used for  $V_{sm}$ .

**Fully Stratified Coarse-Particle Transport** Fully-stratified flow occurs where almost all of the particles travel as contact load (i.e. fluid suspension is ineffective). The ratio of particle diameter to pipe diameter is of major importance in determining the presence of this flow type, which does not normally occur for  $d/D$  ratios less than 0.015. Fully-stratified flow is less likely if the particles are broadly graded, especially if there is a significant homogeneous fraction (i.e. a significant fraction of particles smaller than 200 mesh/75  $\mu\text{m}$ ). Calculations made for narrow-graded slurries with water as a carrier fluid indicate fully-stratified behavior for values of  $d/D$  above 0.018.

Although the actual relationship of the detailed force-balance analysis cannot be expressed in closed form, simple approximating functions can be fitted to match the output of the detailed model. Wilson & Addie (1995) proposed the following expression for approximating fully-stratified flow:

$$\frac{i_m - i_w}{(S_m - 1)} = B' \left( \frac{V_m}{0.55V_{sm}} \right)^{-0.25} \quad (20)$$

The ratio on the left hand side of this equation is the same as that used by Newitt et al. (1955), and the right hand side shows the decrease of this ratio with increasing  $V_m/V_{sm}$ . The coefficient  $B'$  has a value of 1.0 for angular particles, and decreases with the degree of rounding. For typical cases the suggested default value is 0.75. As fully-stratified flow has higher energy consumption than other flow types, Eq. 20 can be thought of as representing the upper limit of excess pressure gradient (i.e. solids effect). Heterogeneous slurry flows, which are covered in the following section, will generally display smaller values of the solids effect.

Another type of stratified flow that may be encountered is flow above a stationary bed of solids. This type of operation is generally uneconomic, and thus is seldom a deliberate design choice, but it is sometimes found in existing pipelines. Flow over a stationary bed has been studied experimentally, and analyzed by a computer model (Nnadi & Wilson, 1992; Pugh, 1995). For most cases of this type of flow encountered in pipelines the following rough approximation to the computer output may be sufficient. It is based on particles near the "Murphian" size, which tend to be disproportionately represented in stationary deposits:

$$i_m = 0.32(S_s - 1)^{1.05} C_{vd}^{0.6} \left( \frac{V_m}{\sqrt{2gD}} \right)^{-0.1} \quad (21)$$

**Pressure Gradients for Partially-Stratified Flow** As mentioned previously, two methods of support are significant in partially-stratified flows: turbulent suspension and granular contact. For turbulent suspension the eddies can carry the particles with no significant additional energy consumption, but granular contacts set up Coulombic friction forces which must be overcome by an additional "solids effect" pressure gradient, represented by  $(i_m - i_f)$  where  $i_f$  (or  $i_w$ ) is the hydraulic gradient for fluid only. In many cases this solids effect varies with the submerged weight of solids, i.e. with  $(S_s - S_p)C_v$  where  $S_f$  is the relative density of the fluid (1.0 for water) and  $C_v$  is the volumetric delivered concentration. The quantity  $(S_s - S_p)C_v$  can also be expressed as  $(S_m - S_p)$  where  $S_m$  is the relative density of the mixture. The relative solids effect, written  $(i_m - i_f)/(S_m - S_p)$ , can be obtained from pipe-loop testing. Typical results for partially-stratified flow are shown on Figure 7 for various concentrations of sand with  $d_{50}$  of 0.016 in. (0.42 mm). The relative solids effect drops with increasing mean velocity  $V_m$ , which in turn produces increased turbulent fluctuating velocities, implying that a larger fraction of particles will be suspended by turbulence. The straight fit line shown on the logarithmic coordinates of Figure 7 indicates that the relation can be approximated by a power law. (Other formulations have also been proposed, see for example Shook & Roco, 1992 and Gillies et al., 1991.)

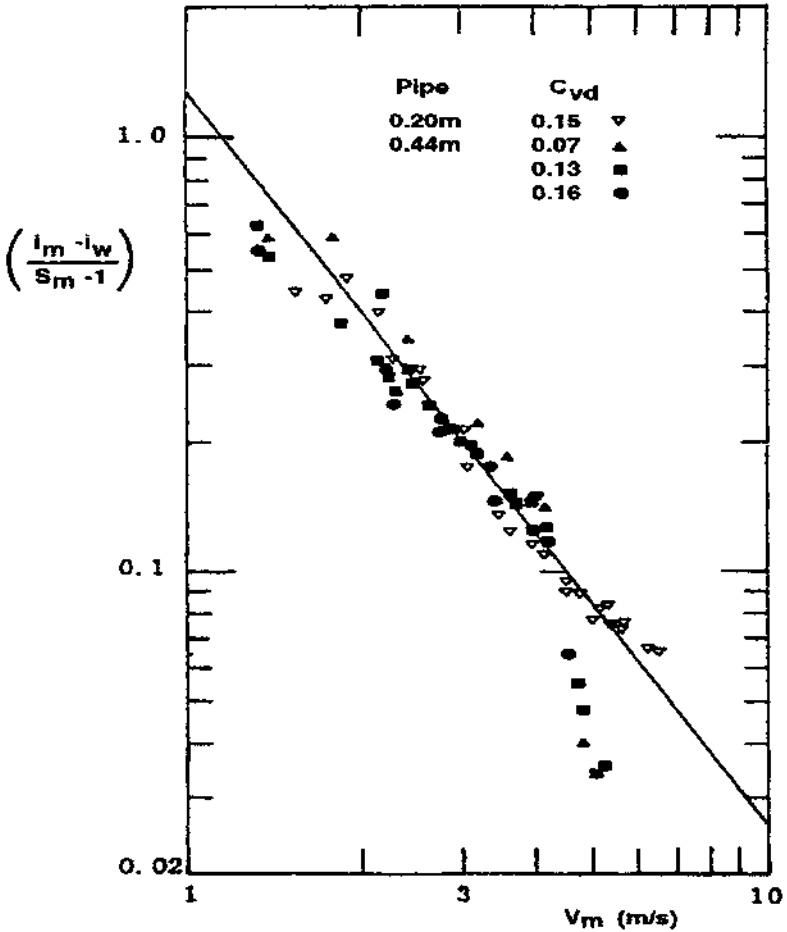


FIGURE 7 Behavior of masonry-sand slurry ( $d_{50} = 0.42$  mm) in pipes of two sizes (after Clift et al., 1983). [ $m \times 3.28 = ft$ ;  $m/s \times 3.28 = ft/s$ ]

In addition to the slope parameter (denoted by  $M$ ) a power law requires a central-value parameter, denoted here by  $V_{50}$ . Conceptually, this represents the value of  $V_m$  at which half the mass of solids is supported by granular contact and half by fluid suspension. From a practical standpoint it is necessary to match this point with a specific value of  $(i_m - i_f)/(S_m - S_f)$ . The mechanics of the situation were discussed by Wilson et al. (1997) who proposed a value of 0.22 and showed that this is supported by experimental data. The resulting equation is

$$\frac{(i_m - i_f)}{(S_m - S_f)} \cong 0.22 \left( \frac{V_m}{V_{50}} \right)^{-M} \quad (22)$$

If test data are available,  $M$  and  $V_{50}$  can be obtained directly from the results. For example consider the data of Figure 7 in the 8 in. (0.20 m) pipe. In calculating the ratio  $(i_m - i_w)/(S_m - 1)$ , the clear water gradient  $i_w$  has been used to approximate  $i_f$ , and  $S_f$  is  $S_w$ ,

i.e. 1.0. The value of  $i_w$  was calculated from the Darcy-Weisbach formula using the friction factor  $f_f = 0.013$  measured previously for flows of water in this pipe. The plotted points fall on an essentially straight line on Figure 7. This behavior corresponds to Eq. 22. The slope of the line gives  $M \approx 1.7$ , which is typical for slurries with narrow particle grading. The point on the line where  $(i_m - i_w)/(S_m - 1) = 0.22$  gives  $V_{50}$ , which is approximately 9 ft/s (2.8 m/s).

With  $V_{50}$  and  $M$  obtained for the 8 in. (0.20 m) pipe, scale-up to a larger pipe diameter can be carried out. The larger diameter of 18 in. (0.44 m) has been selected because data are available with the same sand in this larger pipe (Clift et al., 1982) and thus the scaled-up results can be verified directly. In fact, as seen on Figure 7, the fit line for the larger pipe coincides with that for the smaller pipe in this instance. In this case the clear-water friction factor  $f_w$  was found to be the same for both pipes and in both pipes the particle size  $d$  was a small fraction of the pipe diameter. It has been found that  $V_{50}$  should vary with  $(8/f_w)^{1/2}$ ; it should also depend on the diameter ratio  $d/D$  (Wilson & Watt, 1974; Wilson et al., 1997).

These factors can be incorporated in the scale-up procedure, which involves preparing curves of  $i_m$  versus  $V_m$  for various values of  $C_{vd}$  in the larger pipe, the relation for each line of constant  $C_{vd}$  being expressed as

$$i_m = \frac{f_w}{2gD} V_m^2 + 0.22(S_s - 1)V_{50}^M C_{vd} V_m^{-M} \quad (23)$$

It is typical to find a moderate decrease in  $f_w$  with increasing pipe size, which produces a small increase in  $V_{50}$ . Increases in  $D$  have the opposite effect, but for small ratios of  $d/D$ , as is the case for the data of Figure 7, this effect is not significant.

Other problems arise when pipeline experiments have not been carried out with the particular slurry of interest. In many cases of practical importance, information on the size and grading of the material to be pumped is limited, but estimates of the solids effect must be made. For example, consider the case of an ore that is to be crushed and then transported by pipeline. At the initial stage of the design there may be no adequate sample of the crushed ore, but estimates of the effect of the solids on the head loss must be made for feasibility studies, preliminary designs and cost estimates, and even for justifying the expenses of laboratory or pilot-plant testing.

To estimate the solids effect, two parameters are required: the power  $M$  and the velocity  $V_{50}$ . The value of  $M$  has a lower limit of 0.25 (for fully-stratified flow) and approaches 1.7 for slurries with narrow particle grading. If only a rough idea of the grading is available, it may be adequate to use the following approximation, which requires only an estimate of the particle diameter ratio  $d_{85}/d_{50}$  ( $d_{50}$  is the mass-median particle diameter and  $d_{85}$  is the diameter for which 85% by mass of the particles are smaller). Using this evaluation, the approximation for  $M$  is written

$$M \approx [\ell n(d_{85}/d_{50})]^{-1} \quad (24)$$

Here  $\ell n$  is the natural logarithm. Also,  $M$  should not be allowed to exceed 1.7 or fall below 0.25.

The next step is to obtain a commensurate approximation for  $V_{50}$  (Wilson et al., 1997). This formula reads

$$V_{50} \approx 3.93d_{50}^{0.35}[(S_s - 1)/1.65]^{0.45} \quad (25)$$

Here  $d_{50}$  is in mm. The coefficient 3.93 applies for velocities in m/s; for velocities in ft/s this coefficient becomes 12.9. With sand-weight solids  $(S_s - 1)$  equals 1.65 and the bracketed portion of Eq. 25 equals 1.00. The value of  $V_{50}$  obtained from Eq. 25 is substituted into Eq. 22 to obtain the solids effect  $(i_m - i_p)$ , where  $i_p$  is the gradient for an equal flow of water. Note, Eq. 25 is only applicable for  $0.006 \text{ in} < d_{50} < 0.055 \text{ in}$  ( $0.15 \text{ mm} < d_{50} < 1.4 \text{ mm}$ ). For larger particles the value of  $V_{50}$  given by Eq. 25 should be multiplied by  $\cosh(60d_{50}/D)$ .

**Remarks on Complex Slurry Flows** In the introduction to this section, it was mentioned that slurry flows can be divided into three types on the basis of mechanisms of particle support. These types are homogeneous, partially-stratified and fully stratified, and

the applicable methods of analysis for these flows have been outlined in the appropriate preceding sections. Quite often, the particle grading curve is sufficiently broad to span two of the flow types, or even all three. This gives rise to complex slurry flows. The larger particles, which would settle readily in water, often receive considerable support from the smaller particles and the carrier fluid, promoting efficient transport. A complete analysis of such flows is not yet available, but it is hoped that the following remarks will aid the design engineer.

Whenever some coarse particles settle, they form contact load. As shown in earlier sections of this chapter, this has an effect on pressure drop which is quite different from that of particles suspended by the fluid. The contact-load effect, analyzed previously for the case of a Newtonian carrier fluid, must eventually be combined with the scaling laws for non-Newtonian fluids presented in an earlier part of this chapter. As laminar flows which have significant particle settling are usually avoided in design, only turbulent flows will be considered here.

Maciejewski et al. (1993) compared large-diameter transportation of coarse particles of about 4 in. (100 mm) in clay suspensions and in oil-sand tailings slurries (particle size below 0.03 in./0.8 mm). They found that the sand slurry was more effective as a transport medium than a viscous, homogeneous clay slurry. The important role of particles with sizes of 0.004 to 0.020 in. (0.1 to 0.5 mm) in reducing friction was further shown in studies by Sundqvist et al. (1996a, 1996b) for products with  $d_{50}$  of 0.024 to 0.027 in. (0.6 to 0.7 mm) and various size distributions, with maximum sizes of up to 6 in. (150 mm).

In studying the behavior of complex slurries like these, it is logical to begin by dividing the total concentration of solids  $C_s$  into three components, each associated with a support mechanism. Thus  $C_h$  stands for homogeneous,  $C_{mi}$  for partly stratified (the "middlings") and  $C_{cl}$  for the coarse fully stratified particles (the "clunkers"). On the basis outlined previously the particle size of 200 mesh ( $75 \mu\text{m}$ ) separates  $C_h$  and  $C_{mi}$  and the size  $0.018D$  separates  $C_{mi}$  and  $C_{cl}$ . This point is best illustrated by an example. Take  $S_s = 2.65$ ; and a concentration of 30% by volume ( $C_v = 0.30$ ). From the solids grading curve, suppose that 20% of the total is slimes, 50% middlings and 30% clunkers. Thus, the concentration of slimes in the slurry is  $(0.30)(0.20) = 0.06$ , and similarly 0.15 and 0.09 for middlings and clunkers, respectively. The equivalent fluid based on the slimes has specific gravity  $S_h = 1 + (S_s - 1)C_h = 1 + (1.65)(0.06) = 1.099$  and that for the combined slimes and middlings is  $S_{hmi} = 1 + (1.65)(.21) = 1.347$ . Thus, for the middlings the specific gravity difference between solids and carrier fluid is  $(2.650 - 1.099) = 1.551$  (rather than 1.650). For the clunkers, the equivalent difference is  $(2.650 - 1.347) = 1.303$ .

The homogeneous fraction now forms the carrier fluid for the rest of the slurry, and its hydraulic gradient  $i_h$  replaces  $i_w$  in equations like Eq. 20 and Eq. 22. These are used to determine the solids effect for middlings and clunkers, which may be written  $\Delta i_{mi}$  and  $\Delta i_{cl}$ . The gradient for the mixture  $i_m$  represents the sum of  $i_h$  and the solids effects for the middlings and the clunkers, i.e.

$$i_m = i_h + \Delta i_{mi} + \Delta i_{cl} \quad (26)$$

The homogeneous gradient  $i_h$  is based on appropriate equivalent-fluid or non-Newtonian calculations, as given previously. For the middlings,  $\Delta i_{mi}$  is effectively equivalent to  $(i_m - i_p)$  in Eq. 22, when applied to the middlings only, giving

$$\Delta i_{mi} = C_{mi}(S_s - S_h)0.22 \left( \frac{V_m}{V_{50}} \right)^{-M} \quad (27)$$

Here,  $S_h$  is the relative density of the homogeneous "carrier fluid" component (1.099 for the example just introduced). The evaluation of  $M$  and  $V_{50}$  will be mentioned in the following text.

For the clunkers,  $\Delta i_{cl}$  is based on Eq. 20, except that the carrier fluid for the clunkers now includes both the homogeneous portion and the middlings, with a relative density written  $S_{hmi}$  (1.347 for the example). The carrier fluid will also have an effect on the coefficient which will now be written  $B''$  instead of  $B'$  (the evaluation of  $B''$  will be mentioned next). The relation for  $\Delta i_{cl}$  is

$$\Delta i_{cl} = C_{cl}(S_s - S_{hmi})B'' \left( \frac{V_m}{0.55V_{sm}} \right)^{-0.25} \tag{28}$$

For coarse solids only, it was suggested above that the parameter  $B'$  in Eq. 20 should have a default value of 0.75. When considerable fractions of middlings are found,  $B'$  must be reduced to give  $B''$ . As it is expected that the reduction is associated with density differences, the appropriate variable would appear to be the weight concentration,  $C_w$ , of fines plus middlings, i.e.  $C_{whmi}$  (for the example  $C_{whmi} = 0.372$ ). Thus

$$B'' = B'(1 - \xi C_{whmi}) \tag{29}$$

where  $\xi$  is a coefficient with a proposed default value of unity.

Another point concerns the evaluation of  $V_{50}$  and  $M$  for the middlings. The methods of Eqs. 24 and 25 are basically applicable but  $d_{50}$  and  $d_{85}$  must now refer to the middlings fraction only, rather than the whole grading curve. For very broad well-distributed gradings the middlings will simply be a slice between 0.003 in. (0.075 mm) and 0.018 $D$ . Here it may be possible to assume that  $d_{50}$  is the geometric mean of the two diameter limits (e.g. 0.025 in. for  $D = 1$  ft or 0.64 mm for  $D = 0.305$  m). For this case a default value of about 1.0 might be appropriate for  $M$ .  $V_{50}$  will be influenced by the rheological properties of the homogeneous fraction, which will influence the fall velocity of the middling particles, thus enhancing suspension. An initial approach is to consider the homogeneous part of the slurry to act as a Newtonian fluid with effective viscosity significantly higher than that of water. The effect of enhanced viscosity on  $V_{50}$  is of the form shown on Figure 8. On this figure the value of  $V_{50}$  based on water viscosity is entered on the abscissa (corrected for relative density of solids if different from 2.65). The various curves are for different  $\mu_r$ , the ratio of viscosity to that of water at 70°F (20°C). The multiplier read from the ordinate can be applied to the  $V_{50}$  value for water to estimate  $V_{50}$  in the higher-viscosity carrier fluid.

**EXAMPLE 2** This example pertains to fully-stratified flow of coarse magnetite particles ( $d = 1$  in. or 25 mm). Because of their high relative density ( $S_s = 4.4$ ) these particles are to be used as ballast for an offshore drilling rig. The magnetite will be transferred from ore carriers to the rig by a dredge pipeline with internal diameter 19.7 in. (0.500 m).

- a. Find the deposition limit in this line,  $V_{sm}$ . Figure 6 is entered with the pipe diameter (on the left axis) and the particle diameter (on the demi McDonald).

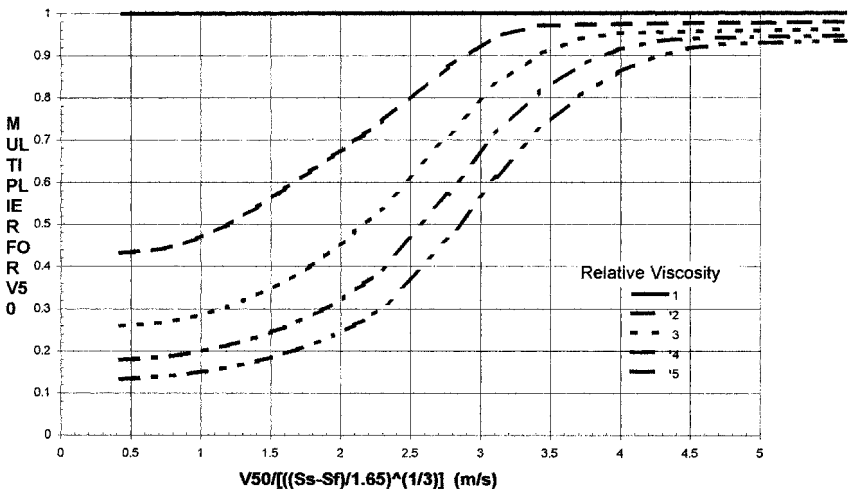


FIGURE 8 Variation of  $V_{50}$  with viscosity

Projection to the central axis gives  $V_{sm} = 8.7$  ft/s (2.65 m/s) for sand-weight material. This number is joined to the relative density  $S$  (i.e.  $S_s$ ) of 4.4 on the sloping axis and projected to the right-hand axis to give  $V_{sm} = 13$  ft/s (4.0 m/s) for the magnetite.

- b. Find the hydraulic gradient  $i_m$  for a volumetric solids concentration of 0.10 and a throughput velocity  $V_m = 16.4$  ft/s (5.0 m/s). Assume rather angular material with  $B' = 0.9$ . The first step is to calculate the clear-water friction gradient of  $i_w$ . Using  $f_w = 0.013$ ,  $i_w$  is given by  $0.013V_m^2/2gD$  or 0.033 (height of water per length of pipe). To this must be added  $(i_m - i_w)$ , which Eq. 20 gives as  $(S_m - 1)B'(V_m/0.55V_{sm})^{-0.25}$ . The quantity  $(S_m - 1)$  equals  $C_v(S_s - 1)$  i.e.  $(0.10)(3.4) = 0.34$ .  $B'$  has been taken as 0.9 and the ratio  $(V_m/0.55V_{sm})$  equals 2.27, giving  $(i_m - i_w) = 0.250$  and  $i_m = 0.28$ , i.e. 28 ft of water per 100 ft of line or 0.28 m of water per m of line. Very large gradients like this, which have been verified in prototype-scale testing, show why fully-stratified flow is only of interest for short-haul applications.

### EXAMPLE 3

- a. Suppose that the magnetite of the previous example has been ground to give  $d_{50} = 0.008$  in. (0.20 mm) and  $d_{85} = 0.012$  in. (0.30 mm). As in the previous example,  $D = 1.64$  ft (0.50 m) and  $V_m = 16.4$  ft/s (5.0 m/s). In this case the volumetric concentration  $C_v = 0.20$ . Find the  $V_{sm}$  and the hydraulic gradient  $i_m$ .

$V_{sm}$  is found as in the previous example. The pipe size is joined to the particle size of 0.008 in. (0.20 mm) and projected to the central axis to give the deposition velocity for sand-weight solids. Solids specific gravity is entered on the sloping line, and projected to the right-hand axis to give  $V_{sm} = 14.4$  ft/s (4.4 m/s). As in the previous example this is less than the proposed operating velocity, which is satisfactory.

The flow of this slurry will be partially stratified, and from Eq. 24,  $M = [\ell n(0.30/0.20)]^{-1} = 2.5$ . However, the maximum limit of  $M$  is 1.70, which will be used here. From Eq. 25,

$$V_{50} = 3.93(0.20)^{0.35} \left( \frac{3.40}{1.65} \right)^{0.45} = 3.1 \text{ m/s (10 ft/s)}$$

For this value of  $V_{50}$ , with  $M = 1.7$  and  $V_m = 16.4$  ft/s (5.0 m/s), the right hand side of Eq. 22 becomes 0.098.  $(S_m - 1)$  equals  $(S_s - 1)(C_v) = (3.40)(0.2) = 0.68$ . Hence

$i_m = i_w + (0.68)(0.098)$ , and with  $i_w$  of 0.033 (found in Example 2)  $i_m$  is found to be 0.100 (ft water per ft or m water/m). Note that this gradient is only about one-third that for the coarse particles of the previous example, despite the fact that the solids concentration (and the tonnage transported) is twice as much.

- b. As in part (a) but with  $d_{85} = 0.016$  in. (0.40 mm). The power  $M$  is re-evaluated as  $M = [\ell n(0.40/0.20)]^{-1} = 1.44$ . For the unchanged values of  $V_{50}$  and  $V_m$ , the right-hand side of Eq. 22 becomes 0.110 and  $i_m$  equals  $0.033 + 0.68 (.110)$  or 0.108 (ft water/ft or m water/m).
- c. As in part (a) but assume that there is a fine-particle fraction that increases the viscosity of the homogeneous component to 4 times that of water. From part (a),  $M = 1.70$  and  $V_{50} = 10$  ft/s (3.1 m/s) in water. Adjusting for the density difference from the sand-water case gives the abscissa of Figure 8 as  $3.1/(3.40/1.65)^{0.33}$  i.e. 7.88 ft/s (2.4 m/s). With this abscissa and a relative viscosity of 4, Figure 8 gives a multiple of 0.42, for a revised estimate of  $V_{50}$  as  $(0.42)(3.1) = 4.3$  ft/s (1.3 m/s). Thus the right/hand side of Eq. 22 becomes 0.022, and  $i_m = .033 + 0.015$  or 0.048 (ft water/ft or m water/m). This revised estimate is only about one-half the value of 0.100 obtained in part (a) for pure water as the carrier fluid.

## OTHER FACTORS

**Vertical Flows** For industrial application of vertical transportation of a solid-liquid mixture in a pipe, the operating velocity must be sufficient to maintain a continuous flow of solids at the discharge end. However, unnecessarily high velocity causes excessive pipe wear and energy losses. The appropriate operating velocity depends on the settling conditions of the solids, indicating that size, density, and concentration of particles are key parameters in the hydraulic design of a vertical particle-fluid transportation system.

Many experimental studies have been made of vertical slurry transport. For example, Sellgren (1979) used a pilot-scale facility with a centrifugal pump to investigate important design parameters for ores and industrial minerals taken from in-plant crushing and milling. The results of these experiments are summarized in the following paragraphs.

It is suggested that the allowable minimum mixture velocity be based on the settling velocity of the largest particles in still water multiplied by a factor of 4 or 5. Provided the velocity exceeds this value, then in most industrial applications, with volumetric concentrations of 15–30%, the corresponding pressure requirement in the vertical system can be determined by the equivalent-fluid model. As noted in connection with Eq. 5, this model is based on the density of the slurry and the friction factor for water. Applied to vertical flow, it gives

$$p = \rho_w g S_m z \left( 1 + \frac{f_w V_m^2}{2gD} \right) \quad (\text{for } V_m > V_{\text{all}}) \quad (30)$$

Here  $p$  is the pressure required,  $S_m$  is the relative density of the slurry,  $z$  is the length of vertical pipe, and  $V_{\text{all}}$  is the allowable minimum mixture velocity, approximately four times the settling velocity of the largest particle.

The settling velocity in still water of industrially-crushed mineral particles is normally reduced significantly compared to smooth spheres of corresponding size. Tests have shown that, on average the settling velocity for particles in the range of 0.04 in. to 1.2 in. (1 mm to 30 mm) is reduced approximately 50%. Therefore, the criterion previously given for the minimum allowable velocity could alternatively be formulated as:  $V_{\text{all}}$  is twice the settling velocity of a smooth sphere of the same size as the largest particles.

Within the constraints previously discussed, systems operate under conditions where the effect of relative velocity between the components appears to be negligible. The maximum particle sizes considered are in the range of 0.04 in. to 1.2 in. (1 mm to 30 mm) in pipe diameters of 4 to 12 in. (0.1 m to 0.3 m). With larger particle sizes (up to 4 to 6 in./100 to 150 mm) and low concentrations, the relative velocity between the components becomes significant. Boundary-layer transitional effects may also introduce certain instabilities that must be carefully evaluated in long vertical risers. Particles larger than one-fifth the pipe diameter can promote slugging instability in vertical hoisting, and particles larger than one-third the pipe diameter may jam the pipe and should be avoided.

**EXAMPLE 4** Centrifugal slurry pumps are used to pump a sand slurry ( $d_{50} = 0.06$  in./1.5 mm) out of a quarry. The pipe is vertical with a length of 328 ft. (100 m) and a diameter of 4 in. (0.10 m). Tests have shown that the settling velocity of the largest particles is approximately 1.5 ft/s (0.45 m/s). Select the operating velocity and calculate the head requirement in meters of slurry.

**Solution** Following the guidelines previously given, the velocity  $V_{\text{all}}$  is four times 0.45, i.e. 6 ft/s (1.8 m/s). At this velocity,  $V_m^2/2g$  is 0.54 ft (0.165 m). With the friction factor  $f_w$  taken as 0.016 for smooth-pipe conditions (see Figure 2), the head is obtained from Eq. 30 as

$$328 \left[ 1 + \frac{0.016(0.541)}{3.94/12} \right] = 336.5 \text{ ft of slurry}$$

in USCS units or 336.5  $S_m$  in ft of water.



In SI units the calculation becomes

$$100 \left[ 1 + \frac{0.016(0.165)}{0.1} \right] = 102.6 \text{ m of slurry}$$

or  $102.6 S_m$  in meters of water.

**Inclined Flows** Lengths of pipe with an adverse slope often form part of pipelines transporting solids. Compared to the horizontal case, flow up an incline tends to require higher throughput velocities in order to avoid deposition. This is of greatest significance for coarse-particle flow.

In an experimental investigation carried out by Wilson & Tse (1984), four particle sizes between 0.04 and 0.24 in. (1 and 6 mm) were tested in a pipe at angles of inclination up to 40 degrees from the horizontal. It was found that the velocity at the limit of deposition initially increases with the angle of upward inclination,  $\theta$ , reaching a maximum when this angle is about 30 degrees. For the materials tested this maximum velocity was approximately 50 percent larger than that required to move a deposit in a horizontal pipe. This large difference is clearly a matter of importance for both design and operation of pipelines with inclined sections.

As indicated schematically on Figure 1,  $V_{sm}$  marks the lower end of the range of desirable operating velocities for a pipeline. For purposes of comparison, it is appropriate to represent the deposition limit for inclined flow in terms of the dimensionless velocity, or Durand number,  $V_{sm}/[2g(S_s - 1)D]^{1/2}$ . The difference between the Durand number for inclined flow and that for horizontal flow,  $\Delta D$ , is plotted against  $\theta$  on Figure 9.

For the effect of pipe inclination on friction loss, the following widely-used formula by Worster & Denny (1955) may be employed for heterogeneous flows and homogeneous flows in which the hold-up effects are small. Their approach, based on water as the carrier fluid, deals with the extra pressure gradient ( $\Delta i(\theta)$ ), expressed in height of water per length of pipe) beyond that for pumping water alone. For horizontal flow, this extra gradient is simply the solids effect ( $i_m - i_w$ ), which may be written  $\Delta i(0)$ . Worster and Denny's formula states that

$$\Delta i(\theta) = \Delta i(0) \cos \theta + (S_s - 1) C_{od} \sin \theta \quad (31)$$

For highly stratified flows, Eq. 31 underestimates the losses. For further information see, for example, Wilson et al. (1997).

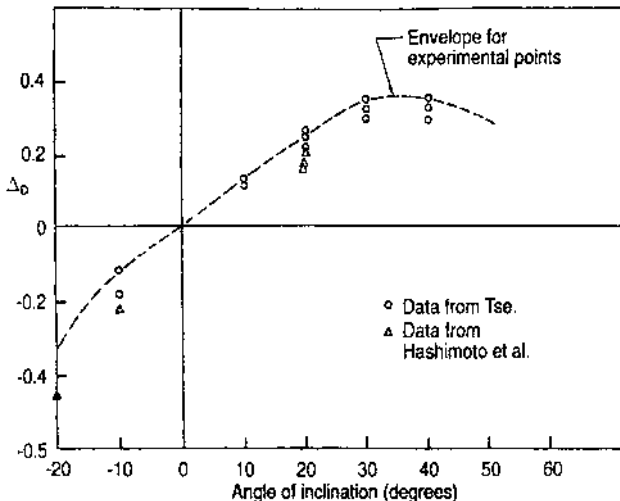


FIGURE 9 Effect of angle of inclination on Durand deposition parameter (after Wilson and Tse, 1984)



**EXAMPLE 5** Consider an inclined suction pipe located on a dredge ladder. Pipe length = 59 ft (18 m),  $D = 25.6$  in. (0.65 m), angle to the horizontal =  $30^\circ$ . Determine the deposition velocity and the head losses at the proposed operating velocity of 21.3 ft/s (6.5 m/s). Assume  $S_s = 2.65$  and  $C_v = 0.20$ . For a horizontal pipe, it is calculated that  $V_{sm} = 15.7$  ft/s (4.8 m/s) and at the proposed operating velocity  $i_w = 0.0373$ ,  $(i_m - i_w) = 0.0239$ .

**Solution** From Figure 9, at  $30^\circ$ ,  $\Delta D = 0.33$ , equivalent to an increase in  $V_{sm}$  of

$$0.33[(64.4) \cdot 1.65(25.6/12)]^{1/2} = 5.0 \text{ ft/s}$$

in USCS units, or

$$0.33[(19.62)(1.65)(0.65)]^{1/2} = 1.5 \text{ m/s}$$

in SI units.

The resulting limit velocity in the inclined pipe is  $15.7 + 5.0 = 20.7$  ft/s,  $4.8 + 1.5 = 6.3$  m/s, which is slightly less than the proposed operating velocity. At the operating velocity Eq. 31 gives the excess gradient,  $\Delta i(30^\circ)$ , as

$$\Delta i(30^\circ) = 0.0239 \cos 30^\circ + (1.65)(0.20) \sin 30^\circ$$

where 0.0239 represents the solids effect in the horizontal pipe. Thus  $\Delta i(30^\circ)$  equals  $0.0207 + 0.1650$  or  $0.1857$ . The clear water gradient  $i_w$  was 0.0373, giving a total value of 0.223, and on multiplying this by the suction-pipe length of 59 ft (18 m), the drop is found to be 13.2 ft (4.0 m) of water.

## SYSTEM DESIGN AND ANALYSIS

**Operating and Economic Considerations** In order to compare the merits of different transport systems, it is necessary to have a measure of the energy required to move a given quantity of product over a given distance. In slurry transport, the solids are normally the “payload” while the conveying liquid is merely the “vehicle.” The specific energy consumption is therefore to be related to the solids transported rather than to the mixture. However, the power which the pump must supply is used to drive the slurry as a whole, and is given by  $\rho_w g Q_m H$  where  $H$  is the head in height of water and  $Q_m$  is the volumetric flow rate of the mixture. The payload of solids is delivered over the line length,  $L$ , at a volumetric rate that is the product of the delivered solids concentration  $C_{vd}$  and the mixture flow rate. If the application is a hoisting system, with the line directed vertically upwards, the rate at which energy is being added to the solids is  $\rho_s g C_{vd} Q_m L$  or  $\rho_w g S_s C_{vd} Q_m L$ , and the efficiency of the system can be obtained by dividing the power input, giving  $S_s C_{vd} L/H$ . In this case the specific energy consumption is the inverse of the efficiency i.e.

$$\text{SEC} = \frac{H}{S_s C_{vd} L} \quad (33)$$

where, as before,  $H$  is the head supplied by the pump in height of water.

In the more usual case of an essentially horizontal pipeline, potential energy will not be added to the solids, and thus from the physicist’s viewpoint no work will be done. However, in industrial practice transporting solids along the line represents useful work in the economic sense. We can no longer speak of efficiency in the physicist’s terminology, but the appropriate economic measure of specific energy consumption is still given by Eq. 33. With  $H/L$  now equal to the friction gradient,  $i_m$ , the expression is written

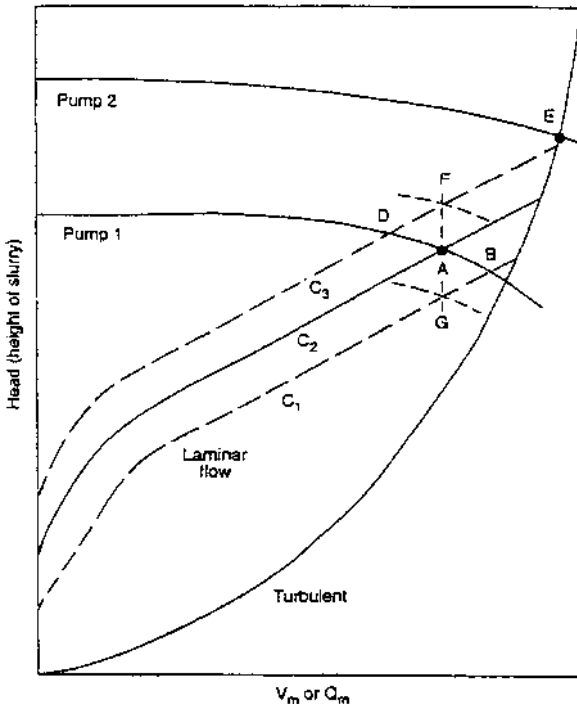
$$\text{SEC} = \frac{i_m}{S_s C_{vd}} \quad (34)$$

To obtain a value in horsepower-hour/ton-mile, this ratio is multiplied by 5.33, and for kWh/tonne-km the factor is 2.73. If the power supplied to the pump is required, the expression must be divided by pump efficiency, and the efficiency of the drive train or motor can be taken into account in the same way.

The lower the SEC, the more energy-effective the pipeline is as a means of transport. Since  $S_s$  is fixed by the nature of the solids, the quotient  $i_m/C_{sd}$  is the basic variable to be considered.

**Homogeneous Slurries** Figure 10 is from Chapter 12 (written by Clift) of Wilson et al. (1997). The figure shows in simple generalized terms, the effect of changes in solids concentration on the resistance of a piping system to flow of a homogeneous, non-settling slurry. At velocities sufficiently high for the slurry to be in turbulent flow, the head lost in flowing through the system (measured as head of a fluid with the slurry density) can be estimated by treating the slurry as a fluid with an effectively constant friction factor, as shown in connection with Eq. 13. However, in laminar flow, to the left of the turbulent curve, the system head varies strongly with concentration, as shown schematically in Figure 10 where  $C_1 < C_2 < C_3$ . The transition between laminar and turbulent flow is indicated roughly by the intersection of the laminar system characteristic with the turbulent curve. Therefore, as is illustrated, the transition velocity increases somewhat with solids concentration.

To examine the operability of such a system with centrifugal pumps, we now superimpose the pump head-discharge characteristic on to the system characteristic. For fine slurries the head delivered by the pump, evaluated in terms of the slurry density, is virtually unaffected by the solids. Therefore the characteristic of a fixed speed pump appears as a single curve in the coordinates of Figure 10, independent of slurry concentration.



**FIGURE 10** Schematic system and pump characteristics for flow of a homogeneous slurry at three concentrations (from Wilson et al., 1997)

Consider first a system which has been designed to operate in the laminar range, corresponding to point A in Figure 10 with slurry concentration  $C_2$ . The curve labeled "Pump 1" represents the characteristic of a pump selected for this operating point.

Figure 10 shows the effect of varying solids concentration. If it decreases to  $C_1$  then the system operating shifts to point B, the new intersection of the system and pump characteristics. Similarly, a concentration increase to  $C_2$  shifts operation to point D. It was shown on Figure 3 that relatively small variations in concentration can have strong effects on the laminar flow curves. Thus the shifts from point A may result from quite small changes in slurry consistency. Nevertheless, as shown by Figure 10, the associated changes in mean velocity (and hence solids throughput) are amplified by the way the system and pump characteristics intersect. Thus steady operation in laminar flow with a fixed-speed centrifugal pump and with no flow control valve is possible only if the slurry consistency is tightly controlled.

For variable solids concentration, two alternatives are available. One is to operate in turbulent flow, at a point like E in Figure 10. "Pump 2" shows the head-discharge characteristics of a centrifugal pump selected for this duty. By operating on the turbulent system characteristic, variations in slurry consistency can be accommodated without significant changes in mixture velocity. This is probably the main reason why many designers prefer to use turbulent flow even for homogeneous slurries. The design point is then selected to be in the turbulent range for the highest solids concentration expected. However, it should be noted that this will not correspond to the lowest specific energy consumption. This is an example of the general point that design for variable operation is usually incompatible with design for minimum energy consumption.

The other option is to use a variable-speed pump. This is illustrated by points F and G in Figure 10. If the solids concentration increases from  $C_2$  to  $C_3$ , then the pump speed is increased to keep a constant flow rate. The corresponding increase in pump speed raises the pump head-discharge characteristic to the broken curve shown passing through F. Similarly, if the concentration falls from  $C_2$  to  $C_1$ , the pump is slowed down to give the characteristic passing through point G. Again, it must be noted that there is an economic penalty for designing for variable concentration, this time represented by the cost of the variable-speed drive and the energy losses in the drive train.

**Settling Slurries** We now turn to problems of system operability for settling slurries. (For a more detailed treatment see Wilson et al., 1997.) Figure 11 shows typical "system characteristics" for a settling slurry at three delivered concentrations, in terms of head of slurry,  $j_m$ . Only the frictional contribution for horizontal transport is considered here. The form of the system characteristics is typical of heterogeneous flow of a settling slurry. The three slurry characteristics are scaled for three notional delivered relative densities, i.e. three values of  $S_{md}$ . The slurry curves all show the minima typical of a heterogeneous slurry flow. As is typical for heterogeneous slurries, the minimum friction gradient occurs at velocities above the deposition point and the position of the minimum moves to somewhat higher velocities as the solids concentration increases.

Figure 11 also shows the point where  $j_m$  equals  $i_w$ . At this crossing point (but not elsewhere) the heterogeneous slurry behaves like an "equivalent fluid," with a value of 1.0 for the coefficient  $A'$  in the homogeneous-flow equation (Eq. 5).

It is now appropriate to consider the behavior of this system with one or more variable-speed centrifugal pumps, with characteristics shown in Figure 11 as "Pump (water)" and "Pump (mixture)." The latter decreases with increasing concentration, due to the effects of solids on pump performance discussed earlier in this section. Therefore, to maintain a constant head and flow rate at point A in Figure 11, the pump rotational speed must be adjusted for the actual solids concentration.

It sometimes happens in industrial practice that the pipeline characteristics for different concentrations cross over at a single point at the water curve and at a suitable operating velocity, as shown schematically in Figure 11. This behavior is expected for closely-graded materials with volumetric concentrations less than 20%, but may not apply for broad gradings or higher concentrations. The results with the broadly-graded sand in Table 3 show that  $j_m$  was approximately constant (equal to 0.055 over a concentration range 20% to 40%) for the selected velocity = 15 ft/s (4.5 m/s). However, the operating point

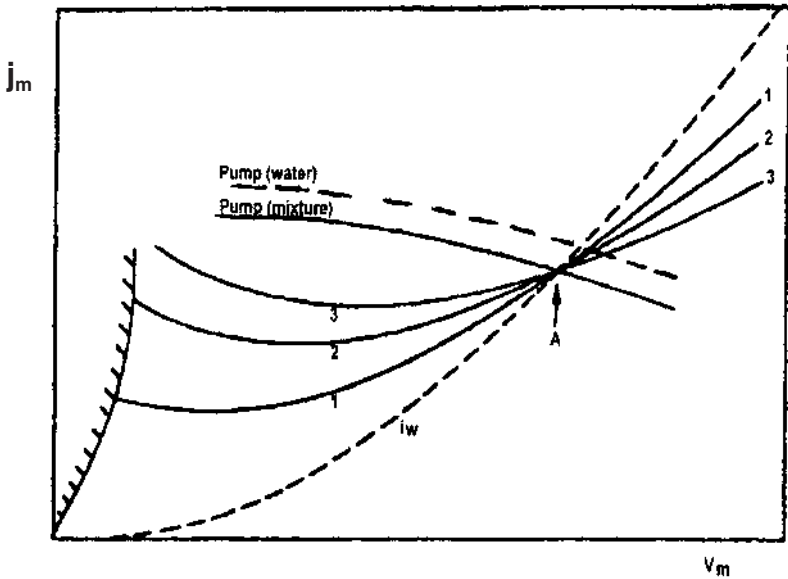


FIGURE 11 Schematic system and pump characteristics for heterogeneous (settling) slurry flow at various delivered concentrations (after Wilson *et al.*, 1997)

TABLE 3 Comparison of slurry friction losses and water friction losses for a broadly graded sand with  $d_{85}/d_{50} \approx 7.1$ . Data from Sundqvist *et al.* (1996a)

Product	Sand		
Max. particle size, in. (mm)	0.4 (10)		
Average, $d_{50}$ , in. (mm)	0.025 (0.65)		
Portion of fine particles, $X_f$ , %	0		
Pipeline—Diameter, in. (m)	12 (0.3)		
Velocity, ft/s (m/s)	15 (4.5)		
Water friction losses, $i_w$	0.041		
Conc. by volume, $C_v$	0.20	0.30	0.40
Slurry friction losses, $j_m$	0.055	0.055	0.055

was not located on the water curve ( $i_w = 0.041$ ). It follows from Table 3 that the slurry friction losses,  $j_m$ , exceeded the corresponding water losses,  $i_w$ , by 35%.

The operating data for the sand in Table 3 are of great practical interest since they demonstrate the energy-efficiency of transporting this product at very high solids concentrations. Experiments by Sellgren & Addie (1993) with this sand indicated that the pump solids effect was not influenced greatly by increased solids concentrations. For the highest concentration studied here, the maximum values of  $R_H$  and  $R_\eta$  were estimated to be 13 and 15%, respectively. An example including pipeline friction and the effect of solids on the water efficiency of the pump is given in Table 4.

It follows that the energy required to overcome friction losses decreased from 0.039 to 0.024 HPh/ton (0.032 to 0.020 kWh/tonne) when  $C_{wd}$  was increased from 20 to 40%. The decrease corresponds to about 37%. The capacity of the pipeline is in this case doubled by the increase in concentration. Because the pump solids effect for this product and pump

**TABLE 4** Data for the sand slurry of Table 3 in a 12 in. (0.3 m) diameter pipe using a 14 in. (0.35 m) by 12 in. (0.3 m) conventional heavy-duty pump with an impeller diameter of 36 in. (0.91 m). Pipeline length = 852 ft (260 m), flow rate = 5200 US gpm (328 l/s) and velocity = 15 ft/s (4.5 m/s). Volumetric concentrations 20, 30 and 40% (from Sellgren and Addie, 1996)

	Concentrations by volume (%)		
	20	30	40
Capacity, ton/h (tonne/h)	690 (627)	1035 (941)	1380 (1255)
Energy to overcome pipeline friction, HPh/ton (kWh/tonne)	0.039 (0.032)	0.029 (0.024)	0.024 (0.020)
Pump head reduction, $R_H$ (%)	8	11	13
Required rotary speed (rpm)	333	338	342
Pump water efficiency (%)	79.5	79.4	79.3
Pump efficiency reduction, $R_\eta$ (%)	6	11	15
Pump efficiency (%)	74.8	70.7	67.4
Total energy, HPh/ton (kWh/tonne)	0.052 (0.043)	0.041 (0.034)	0.037 (0.030)

remained fairly moderate also for the highest concentration, the total energy requirement per tonne decreased from 0.052 to 0.037 (0.043 to 0.030) with an increased  $C_{vd}$  value from 20 to 40%. The lowering then corresponds to about 30%.

The attrition of coarse and angular particles during circulation in a test-loop may have a strong influence on friction losses and pump performance. However, the results in Tables 3 and 4 with high solids concentrations and coarse particles embedded in a sand slurry are not expected to have been significantly influenced by circulation effects. In large-scale loop testing special loading and quick measurement procedures are now used to evaluate the interaction of particle attrition, pipeline friction and pump performance. In general, designing a system to transport a slurry combining broad grading and high concentration requires pilot plant testing using the same material that will be pumped in the prototype line.

The solids concentration used throughout this section (denoted  $C_v$  or  $C_{vd}$ ) refers to delivered concentration, and this is incorporated in the design-oriented equations. Large particles tend to have a lower velocity than small ones, and thus a larger resident (*in situ*) concentration in the pipeline, and this feature should also be considered in designing on- through pipelines on the basis of recirculating test-loop data.

For long-distance freight pipelines it is worthwhile to devote considerable effort to preparing and controlling slurry properties. For such lines solids concentrations range from 0.25 (25%) for ores with  $S_g$  of, say, 5.0, to 0.40 (40%) for coal with  $S_g = 1.4$ . Velocities are usually maintained below 6.6 ft/s (2.0 m/s). For a typical 10 in. (0.25 m) pipe, annual throughput of solids range from about 2.8 M tons (2.8 M tonnes) for ore to 1.4 M tons (1.3 M tonnes) for coal. The corresponding specific energy consumption, including a total pump and drive-train efficiency of 75%, are respectively, 0.13 and 0.17 HPh/ton-mile (0.065 and 0.085 kWh/ton-km). For such cases the energy cost for pumping amounts to roughly half the annual operating cost. This cost is, say, 20% to 30% of the total annual cost, which is seen to be dominated by repayment of capital expenditure.

## REFERENCES

- Blatch, N. S. (1906). Discussion of "Works for the purification of the water supply of Washington D.C." (Hazen, A. and Hardy, E. D.) *Trans Amer. Soc. Civil Engrs.* Vol. 57, pp. 400-409.
- Brown, N. & Heywood, N. (1992). *Slurry Handling Design of Solid-Liquid Systems*. Elsevier Science Publishers, United Kingdom.

- Carstens, M. R. & Addie, G. R. (1981). A sand-water slurry experiment. *Jour. Hydr. Div. ASCE*, Vol. 107, No. HY4, pp. 501–507.
- Clift, R. Wilson, K. C., Addie, G. R. and Carstens, M. R. (1982). A mechanisitically-based method for scaling pipeline tests for settling slurries.
- Durand, R. (1951a). Transport hydraulique des matériaux solides en conduite, études expérimentales pour les cendres de la central Arrighi. *Houille Blanche*, Vol. 6, No. 3, pp. 384–393.
- Durand, R. (1951b). Transport hydraulique des graviers et galets en conduite. *Houille Blanche*, Vol. 6, No. B, pp. 609–619.
- Gillies, R. G., Shook, C. A. and Wilson, K. C. (1991). An improved two layer model for horizontal slurry pipeline flow. *Canad. J. Chem. Engng.*, **69**, 173–178.
- Hedström, B. O. A. (1952). Flow of plastics materials in pipes. *Ind. and Eng. Chem.*, Vol. 44, No. 3, pp. 651–656.
- Kostuik, S. P. (1966). Hydraulic hoisting and pilot-plant investigation of the pipeline transport of crushed magnetite. *The Canadian Mining and Metallurgical Bulletin*, January, 25–38.
- Lumley, J. L. (1973). Drag reduction in turbulent flow by polymer additives, *J. Poly Sci., Macromol. Rev.* 7, A. Peterlin (Ed.), Interscience, New York, pp. 263–290 (1973).
- Lumley, J. L. (1978). Two-phase flow and non-Newtonian flow. In *Turbulence*, P. Bradshaw (Ed.), Topics in Applied Physics, Vol. 12, Springer-Verlag, Berlin (1978), Chapter 7.
- Maciejewski, W., Oxenford, J. and Shook, C. (1993). Transport of Coarse Rock with Sand and Clay Slurries, *Hydrotransport*, 12, Brügge, Belgium, pp. 705–724.
- Mooney, M. (1931). Explicit formulas for slip and fluidity. *J. Rheol.* Vol. 2, p. 210 ff.
- Newitt, D. M., Richardson, J. F., Abbot, M., & Turtle, R. B. (1955). Hydraulic conveying of solids in horizontal pipes. *Trans. Inst. of Chem. Engrs.*, Vol. 33, London, U.K.
- Nnadi, F. N. & Wilson, K. C. (1992). Motion of contact load at high shear stress. *J. Hydr. Engrg.*, ASCE **118** (12), pp. 1670–1684.
- Pugh, F. J. (1995). *Bed-load Velocity and Concentration Profiles in High Shear Stress Flows*. Ph.D. Thesis, Queen's University, Canada.
- Rabinowitsch, B. (1929). Über die Viscosität von Solen. *Zeitschrift physik. Chem.*, **A 145**, p. 1 ff.
- Sellgren, A. & Addie, G. (1996). Pump and pipeline solids effects of transporting sands with different size distributions and concentrations. *Proc. 13th Int. Conference on the Hydraulic Transport of Solids in Pipes*, Johannesburg, South Africa, pp. 227–236.
- Sellgren, A. & Addie, G. (1998). Effective integrated mine waste handling with slurry pumping. *Proceedings Fifth International Conference on Tailings and Mine Waste*. January 26–28, Ft. Collins, USA, pp. 103–107.
- Shook, C. A. and Roco, M. C. (1991). *Slurry Flow Principles and Practice*. Butterworth-Heinemann.
- Sundqvist, A., Sellgren, A. and Addie, G. R. (1996a). Pipeline friction losses of coarse and slurries: comparison with a design model, in *Powder Technology*, **89**, pp. 9–18.
- Sundqvist, A., Sellgren, A. and Addie, G. R. (1996b). Slurry pipeline friction losses for coarse and high-density industrial products, in *Powder Technology*, **89**, pp. 19–28.
- Thomas, A. D. (1979). The role of laminar/turbulent transition in determining the critical deposit velocity and the operating pressure gradient for long distance slurry pipelines, *Proc. Hydrotransport 6*, BHRA Fluid Engineering, Cranfield, UK, pp. 13–26.
- Thomas, D. G. (1963). Non-Newtonian suspensions. Part 1, physical properties and laminar transport characteristics. *Ind. and Eng. Chem.* Vol. 55, No. 11, pp. 18–29.
- Thomas, A. D. & Wilson, K. C. (1987). New analysis of non-Newtonian turbulent flow—yield-power-law fluids. *Canad. J. Chem. Engrg.*, Vol. 65, pp. 335–338.

- Wilson, K. C. (1979). Deposition-limit nomograms for particles of various densities in pipeline flow, *Proc. Hydrotransport 6*, BHRA Fluid Engineering, Cranfield, UK, pp. 1–12.
- Wilson, K. C. (1986). Modelling the effects of non-Newtonian and time-dependent slurry behavior. *Proc. Hydrotransport 10*, BHRA Fluid Engineering, Cranfield, UK, pp. 283–289.
- Wilson, K. C. (1988). Evaluation of interfacial friction for pipeline transport models. *Proc. Hydrotransport 11*, BHRA Fluid Engineering, Cranfield, UK, pp. 107–116.
- Wilson, K. C. (1989). Two mechanisms for drag reduction. *Drag Reduction in Fluid Flows, Techniques for Friction Control*, Ed. H. R. J. Sellina and R. T. Moses, pp. 1–8. Ellis Horwood Ltd., Chichester, UK.
- Wilson, K. C. & Addie, G. R. (1995). Coarse-particle pipeline transport: effect of particle degradation on friction. *Proc. 8th International Freight Pipeline Society Symposium*, pp. 151–156.
- Wilson, K. C., & Judge, D. G. (1978). Analytically-based nomographic charts for sand-water flow, *Proc. Hydrotransport 5*, Solids in Pipes, BHRA Fluid Engineering, Cranfield, UK, pp. A1-1–11.
- Wilson, K. C., & Nnadi, F. N. (1990). Behavior of mobile beds at high shear stress. *Proc. 22nd Int'l Conference on Coastal Engineering*, Delft, Netherlands, Vol. 3, pp. 2536–2541.
- Wilson, K. C., & Thomas, A. D. (1985). A new analysis of the turbulent flow of non-Newtonian fluids. *Canad. J. Chem. Engrg.*, Vol. 63, pp. 539–546.
- Wilson, K. C., & Tse, J. K. P. (1984). Deposition limit for coarse-particle transport in inclined pipes. *Proc. Hydrotransport 9*, BHRA Fluid Engineering, Cranfield, UK, pp. 149–169.
- Wilson, K. C. & Watt, W. E. (1974). Influence of particle diameter on the turbulent support of solids in pipeline flow. *Prod. Hydrotransport 3*, BHRA Fluid Engineering, Cranfield, UK, pp. E1-1–E1-13.
- Wilson, K. C., Addie, G. R., Sellgren, A. and Clift, R. (1997). *Slurry Transport Using Centrifugal Pumps, 2nd Ed.* Blackie (Chapman & Hall).
- Wood, F. M. (1935). Standard nomographic forms for equations in three variables, *Canadian Journal of Research*, Vol. 12.

# 9.16.2 APPLICATION AND CONSTRUCTION OF CENTRIFUGAL SOLIDS HANDLING PUMPS

GRAEME ADDIE  
ANDERS SELLGREN

This section discusses the application of centrifugal pumps to the transport of slurries as introduced in Subsection 9.16.1.

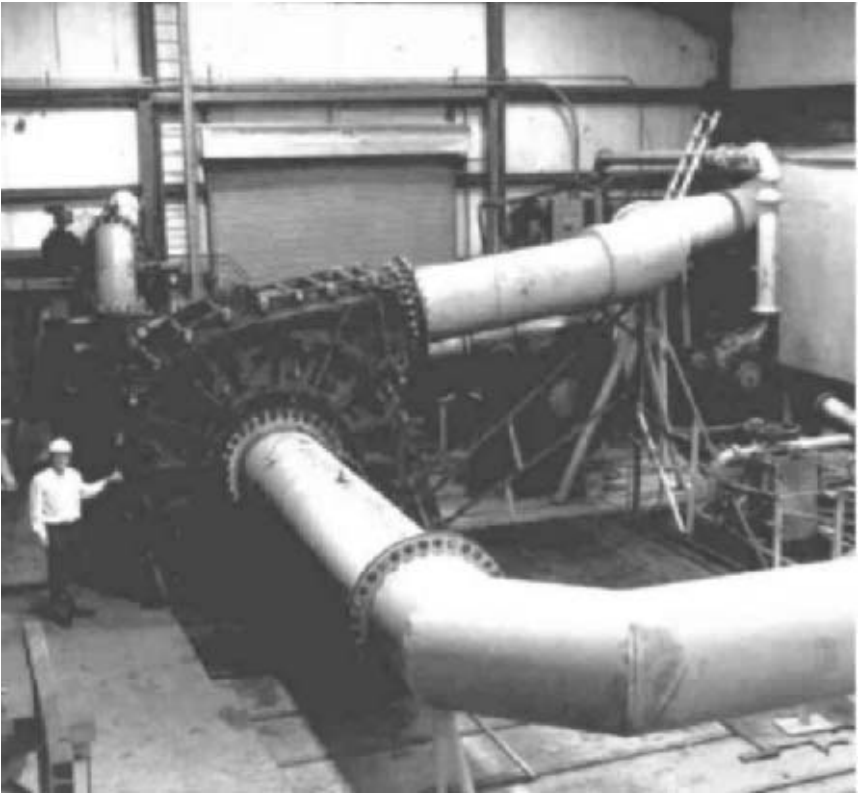
Where the distance is large and the size of the solids less than about 100 microns, positive displacement pumps are usually applied. If the solids to be transported are smaller than about 60 mm in size, water is readily available or already part of the process, and the distance is less than 12 miles (20 km), a pipeline driven by centrifugal slurry pumps is usually more cost-effective than belt conveyors, trucks, or railway transportation.

Types of solids transported vary from sag mill feed in a copper mine, iron ore, phosphate matrix, coal, rock salt, tar sands, red mud, various types of waste tailings, and crushed rock and silt. An 18 in (0.45 m) diameter pipeline, for example, is capable of transporting as many as 2200 tons/hr (2000 tonnes/hr) of sand. This equates to about one hundred truckloads per hour over the distance involved.

The application that involves the largest quantities is in the dredging industry, continually maintaining navigation in harbors and rivers, altering coastlines, and mining material for landfill and construction purposes. Because a single dredge may be required to maintain a throughput of 7000 tons/hr of slurry or more, very large centrifugal pumps are used. Figures 1 and 2 show, respectively, an exterior view of a dredge pump on test, and a view of a large slurry pump impeller (Addie and Helmly, 1989).

Because the aim is to transport solids and not water, the higher the concentration of solids, the better for energy consumption and capital cost. This does, however, mean that wear due to the abrasive solids will be significant, requiring a special type of centrifugal pump design and the use of special materials. Slurry pumps may be selected for low-concentration dirty-water service. Most of what follows, however, is about pumps designed and built to give cost-effective operation for heavy-duty slurry service, probably involving significant wear.





**FIGURE 1** Testing a dredge pump at the GIW hydraulic laboratory

### **SLURRY PUMP TYPES**

---

The majority of centrifugal slurry pumps that fit the above definition are constructed as the single-stage horizontal radially split type. A sectional arrangement drawing of a single-wall metal type is shown in Figure 3. Where elastomers are used, they must be supported with an outer casing or sideplate. This type is commonly referred to as a double-wall type. An example of a double-wall rubber-lined pump is shown as Figure 4.

Vertical cantilever and vertical submersible centrifugal pumps are also built in significant quantities and serve mostly in general cleanup and other service. These pumps on occasion are called upon to operate as transporting devices and, depending on the design and service, include the special features described later.

### **CENTRIFUGAL SLURRY PUMP HYDRAULIC DESIGN**

---

In order to reduce wear, the hydraulic design of a slurry pump should be such that the rotating wetted component and fluid velocities must be kept as low as practical while hard metal or elastomer wetted-section thicknesses are increased. Impeller meridional sections are also usually kept close to rectangular and with front sealing on a vertical face to minimize the axial rotating surfaces. Collectors (casings) are usually semi-volute (or even



FIGURE 2 Dredge pump impeller, 105 in (2.67 m) diameter

annular) to give better wear over a wider range of best-efficiency-point quantity (flow rate) (BEPQ).

Where larger solids are to be pumped, the inside shroud impeller widths are usually oversized, the number of vanes is reduced to two or three, and the vane overlap may be reduced. All of these distortions modify or reduce the hydraulic performance. Given the variety of types (and severity) of services, the design solution that provides the best compromise between wear life and efficiency and provides the end user with the overall lowest total cost of ownership is not simple to achieve. Although specific to a particular slurry type, Kasztejna et al. (1986) and Cooper et al. (1987) provide a good insight into some of the design tradeoffs and special problems involved in the design of a centrifugal slurry pump.

In general, slurry pumps are of low specific speed (as defined in Section 2.1), in the range of 750 to 2000 for  $N_s$  (14.5 to 39 for  $n_q$  and 0.27 to 0.73 for  $\Omega_s$ ). They employ three to five vanes, have impeller inside shroud widths that are 75–200% wider than those a normal water pump, and use impeller vane and shroud thicknesses two to three times that of a water pump. The results of these distortions flatten the constant-speed head-flow curves and reduce efficiency by five or so percent. Typical head coefficients (as defined in Section 2.1) and efficiencies are shown in Figures 5 and 6.

In order to minimize wear over different ranges of percent of BEPQ, operation slurry pump casings vary from the true volute water pump T type (shown schematically on Figure 7) through the semi-volute C type to the essentially annular A type. There are also a few examples of what is called the OB type with recessed tongue and special extended

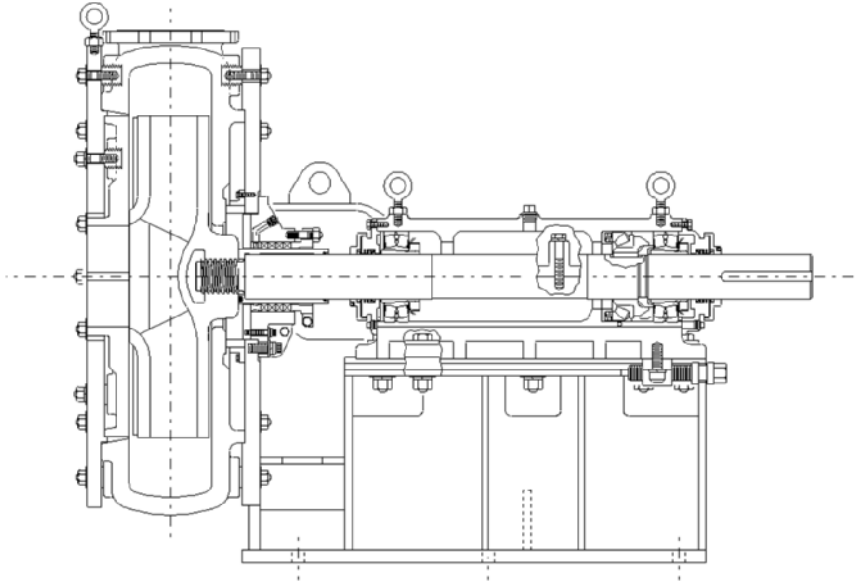


FIGURE 3 Typical single-wall hard iron slurry pump

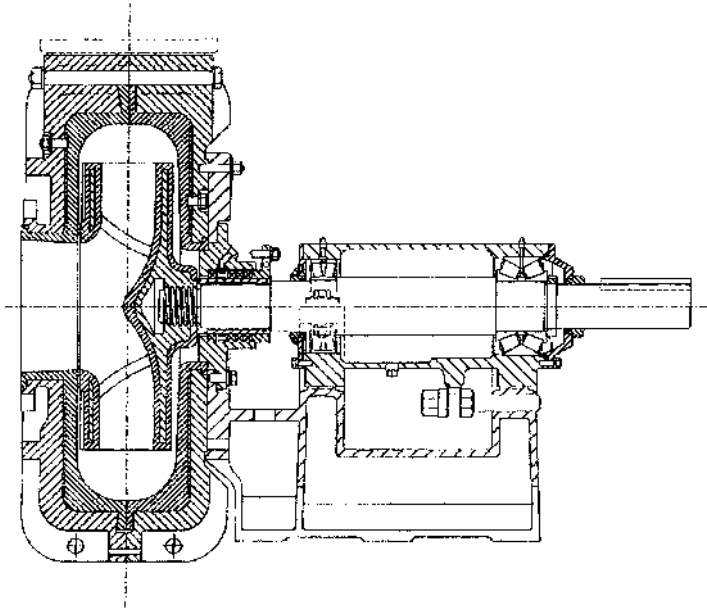
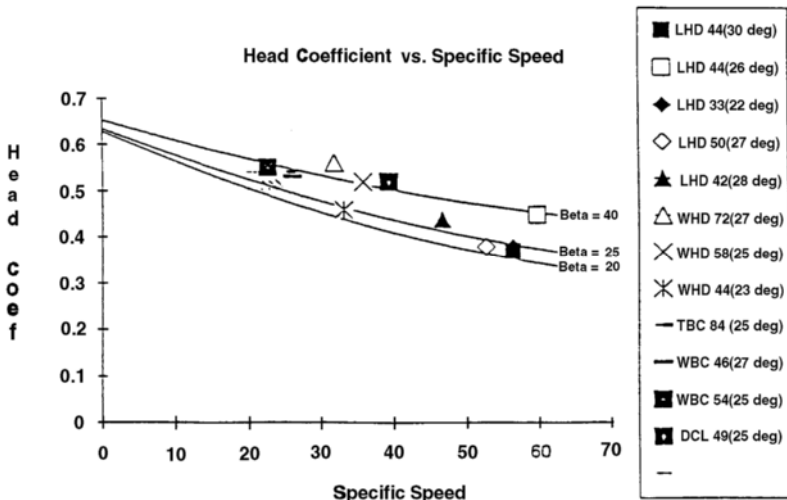
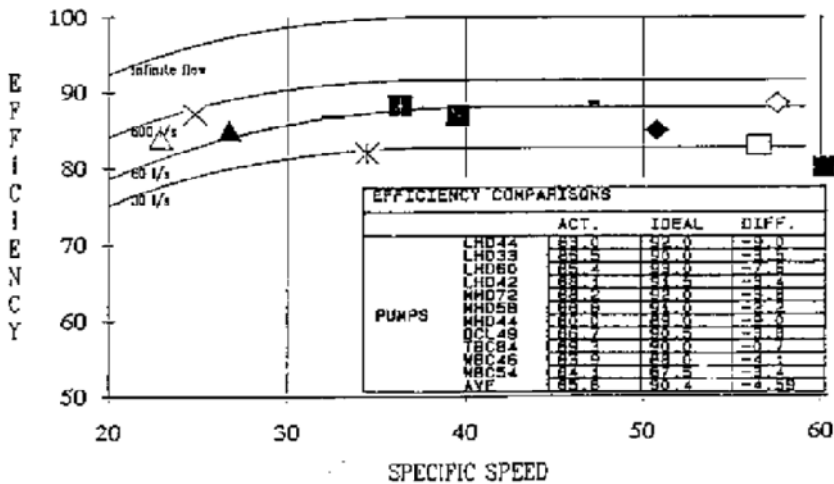


FIGURE 4 Typical double-wall elastomer-lined slurry pump



**FIGURE 5** Head coefficient versus specific speed  $n_q$  based on m<sup>3</sup>/s, m, and rpm (from Addie and Helmlj, 1989). [Note: for specific speed  $N_q$ , based on gpm, ft, and rpm, multiply  $n_q$  by 51.65; for universal specific speed  $\Omega_s$ , divide  $n_q$  by 52.92.]

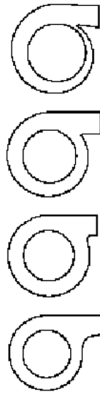
**EFFICIENCY COMPARISONS WITH STANDARDS**



**FIGURE 6** Pump efficiency as a function of specific speed  $n_q$  based on m<sup>3</sup>/s, m, and rpm (from Addie and Helmlj, 1989). [Note: for specific speed  $N_q$ , based on gpm, ft, and rpm, multiply  $n_q$  by 51.65; for universal specific speed  $\Omega_s$ , divide  $n_q$  by 52.92.]

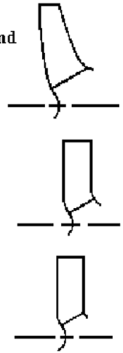
**SHELL TYPES**

- T - TIGHT CUTWATER  
Volute Type
- C - CONVENTIONAL  
Semi-Volute Type
- A - ANNULAR  
Annular Type
- OB - "ODD BALL"  
Extended Neck Type



**IMPELLER TYPES**

- HE - HIGH EFFICIENCY  
Twisted vanes in rounded and narrowed meridional section.
- ME - MEDIUM EFFICIENCY  
Twisted vanes in rounded meridional section.
- RV - RADIAL VANES  
Radial vanes in rectangular meridional section.



**(The ME and RV type impellers are usually interchangeable and use the same suction liner and plate.)**

FIGURE 7 Types of shells (casings) and impellers

**Shell Shape**

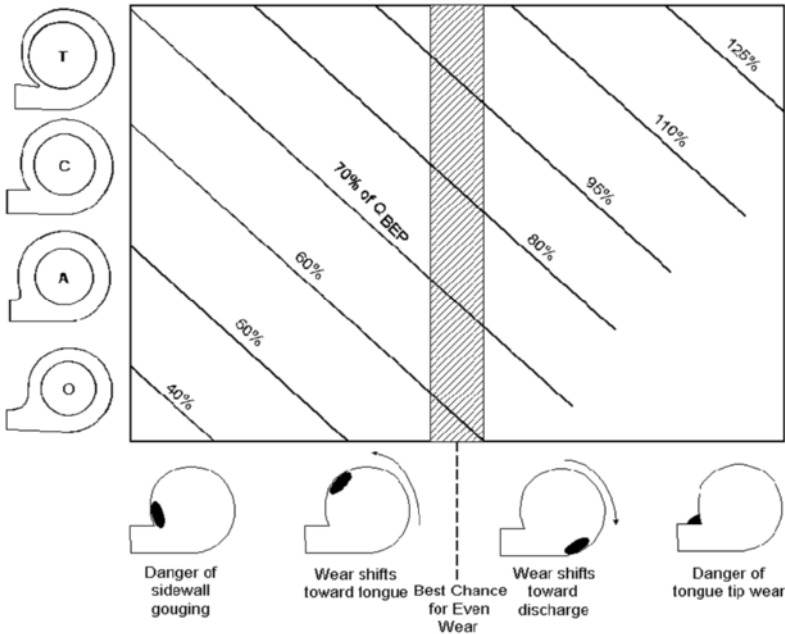


FIGURE 8 Trends in location of casing belly wear

neck intended for limiting wear in the tongue area due to excessive recirculation (which itself is symptomatic of misapplication). The general applicability of each of these is shown in Figure 8, taken from Addie and Helmly (1989).

Impeller types may be roughly categorized also as being of the old-style square meridional section radial vane RV type (still common in rubber-lined pumps where it is difficult to mold a twisted vane), the most common rounded rectangular meridional section with twisted vanes ME type, and the HE type which is closer to a water pump.

Each combination of the types illustrated in Figure 7 has its own hydraulic performance and wear characteristics. The HE/T combination generally has the highest performance, but is not necessarily the most forgiving for wear, whereas the ME/C combination is capable of respectable efficiency while at the same time having more predictable wear performance. In extremely heavy-duty wear service, operation must be at low discharge flow rates—below BEPQ. The A type shell, or even the OB type, could be best for wear where a pump has been misapplied badly. For additional information on the selection of different hydraulic types, see Addie et al. (1996).

Impeller and shells using elastomers such as rubber, neoprene, and urethane tend to be limited to impeller tip speeds less than about 75 ft/s (23 m/s), although this can rise with stiffer elastomers, at some expense to wear life. Impellers employing elastomers require higher available *NPSH* because of the thicker impeller vane sections needed, and this condition may limit their use, for example in pumping flue-gas desulfurization slurries.

## MECHANICAL DESIGN OF SLURRY PUMPS

---

Given the distortions noted earlier the mechanical design of a slurry pump is similar to that of a water pump. Slurry specific gravities (SG) of up to 1.6 and higher may have to be pumped, so the shaft and bearings of necessity must be more robust. Figures 3 and 4 show typical pump bearing housings.

Impeller attachment by an Acme-type screw has generally been found best capable of carrying the heavy loads required, and the connections can be manufactured economically in the hard materials most commonly employed in impellers. The large loads associated with heavy-duty service require roller bearings with separate roller thrust bearings. Designs with ball bearings are suited only for light-service pumps.

The absence of radial sealing in slurry pumps allows shaft deflections larger than those found in water pumps, and these may limit the life of stuffing boxes and mechanical seals. Newer and better designs, however, tend to have shorter shafts and smaller deflections, extending the seal life. A conventional packed stuffing box is still the simplest and most common rotating-assembly seal. Configurations are similar to those used for water pumps, with the lantern-ring supplying a clear-water flush to the center for minimum dilution, or to the product side for maximum life. An expeller-type seal is popular where dilution of the product is unacceptable. These seals are limited to one stage and involve additional efficiency losses, which usually range to 3% or more.

Mechanical seals are now available that take their coolant from the product and operate with no clear-water flush; they are mostly of the single partially balanced type. In some cases, where a pump may run dry, a double type of mechanical seal must be used. At present, mechanical seals are the preferred shaft sealing method for fine-particle light-duty service such as pumps for flue gas desulfurization. These seals are also fairly widely used in the aluminum industry for red-mud pumping service. A mechanical seal described in Maciejewski *et al.* (1993) is used for pumps handling tar sands tailings at pump discharge pressures up to 350 lb/in<sup>2</sup> (2400 kPa), with  $d_{50}$  about 120 microns and average slurry density near 0.0578 lb/in<sup>3</sup> (1600 kg/m<sup>3</sup>). In this case, the process fluid is at an average temperature of about 130°F (55°C) and some 0.16 gpm (0.01 l/s) of water is used for external cooling. In this application, representative of the limits of mechanical seal technology at the present, the average seal life is about 3000 hours.

As noted before, pump casings made entirely of elastomeric materials have insufficient strength to withstand the pressure loads, so it is necessary to have an outer casing of some sort, a configuration that is commonly called a double-wall design. For versatility, some manufacturers make these designs for interchangeable wetted internal shell components of hard metal, rubber, or urethane as the service warrants. For very large slurry pumps, the double-wall configuration is heavy and costly. As a cost-effective design for this case, it

is worth considering tie-bolt construction using high-tensile outer side plates over a hard-metal plate and liners as shown in Figure 1.

Further, single-wall designs with the main shell casing in hard metal are simple to construct and maintain and thus are very popular. These can be used unlined or provided with liners of bonded rubber or other material. Ceramic materials are now available that are capable of several times the life of both elastomer and hard-metal components. At the moment, the cost-effectiveness of these materials is such that their use tends to be limited to areas of high wear and other selected areas of wetted surfaces.

In a shell of single-wall metal design, the wearing components must carry the water load. Wear tends to progress until leakage of the shell occurs, but the wear is almost always localized so leakage occurs before the structural integrity of the assembly is affected. Single-wall designs may easily be ribbed or thickened locally to increase strength and wear life in a particular area. In small slurry pumps, minimum casing thicknesses usually produce safe designs of adequate pressure rating.

### SELECTION OF SLURRY PUMPS

As noted earlier, service conditions vary significantly, so when selecting a slurry pump, a recommended approach is to select a service class and limit nozzle (branch) and other velocities according to that. Figures 9 and 10 from Wilson et al. (1997) outlines an approach that can be used.

For a given service class, Table 1 provides a guide to maximum impeller, nozzle (branch), and other velocities that should give reasonable wear life and keep the cost and size of the pump to a minimum.

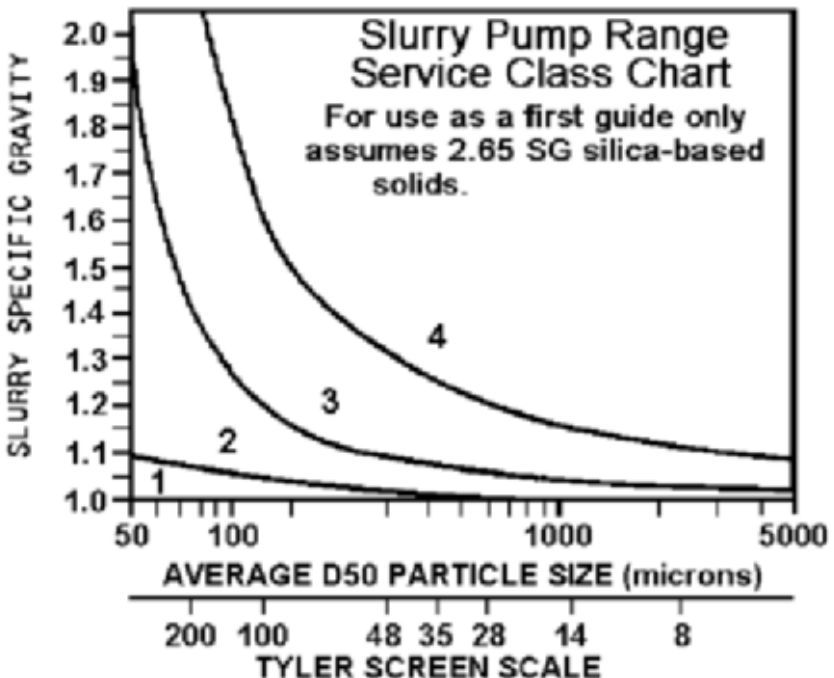


FIGURE 9 Slurry pump range service class chart

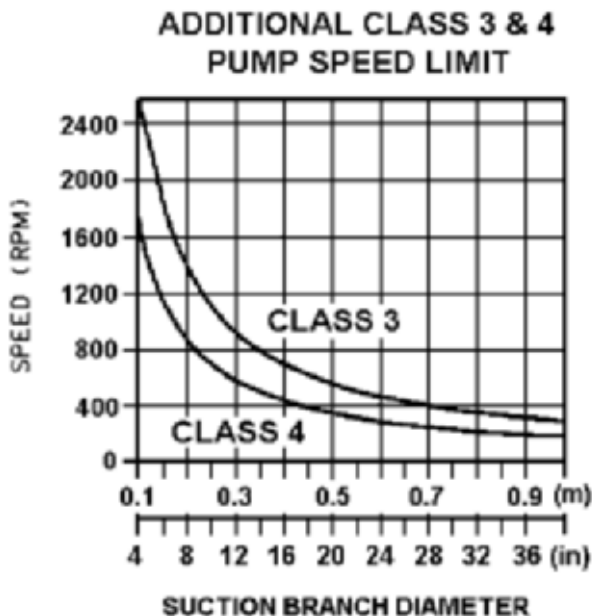


FIGURE 10 Pump speed limit chart for classes 3 and 4

**TABLE 1** Recommended operating limits for slurry pumps

OPERATING* LIMITS	SHELL TYPE	SERVICE CLASS			
		1	2	3	4
MAXIMUM DISCHARGE (R) VELOCITY		40. (ft/s) 12.2 (m/s)	32. (ft/s) 9.8 (m/s)	27. (ft/s) 8.2 (m/s)	20. (ft/s) 6.1 (m/s)
MAXIMUM THROAT (R.) VELOCITY		50. (ft/s) 15.2 (m/s)	40. (ft/s) 12.2 (m/s)	30. (ft/s) 9.1 (m/s)	20. (ft/s) 6.1 (m/s)
RECOMMENDED PERCENT RANGE (C) OF BEP FLOWRATE	ANNULAR (A)	20 - 120%	30 - 110%	40 - 100%	50 - 90%
	SEMI-VOLUTE (C)	30 - 130%	40 - 120%	50 - 110%	60 - 100%
	NEAR VOLUTE (T)	50 - 140%	60 - 130%	70 - 120%	80 - 110%
	ANNULAR/OBLIQU E NECK (OB)	10 - 110%	20 - 100%	30 - 90%	40 - 80%
ALL METAL PUMP MAXIMUM IMPELLER (R) PERIPHERAL SPEED		8500 (sfpm) 43.2 (m/s)	7500 (sfpm) 38.1 (m/s)	6500 (sfpm) 33.0 (m/s)	5500 (sfpm) 27.9 (m/s)
RUBBER LINED PUMP MAXIMUM IMPELLER (R) PERIPHERAL SPEED		5500 (sfpm) 27.9 (m/s)	5000 (sfpm) 25.4 (m/s)	4500 (sfpm) 22.9 (m/s)	4000 (sfpm) 20.3 (m/s)

[Note: sfpm = ft/min; for ft/s, Divide by 60]

Except in the case of dredges (which are usually diesel driven), most slurry pumps are driven by electric motors. Because of the difficulty associated with trimming impeller diameters and variations of system head, it is common for plant slurry pumps up to 250 hp (185 kW) to have V-belt drives. For larger pumps, four pole motors and gearboxes are most common, with one or more variable speed units when there are several (usually up to six) units operating in series.



**SOLIDS EFFECT ON CENTRIFUGAL PUMPS**

The presence of solid particles in the flow tends to produce adverse effects on pump performance, and detailed information on these effects is needed to achieve reliable and energy-efficient operation. Head-flow curves for centrifugal pumps are often rather flat. Also, the pipeline characteristic for slurry flow usually displays a slow rise with increasing discharge. As a result, the two characteristic curves often intercept at a rather shallow angle. Therefore, even a small diminution in pump head can produce a disproportionately large drop in flow rate. The resulting difficulties in operation can cause large and expensive systems to run inefficiently or not run at all.

The effects on pump characteristics are shown schematically in Figure 11, which is a definition sketch for illustrating the reduction in head and efficiency of a centrifugal pump operating at constant rotary speed and handling a solid-water mixture. In this sketch, and the discussion that follows,  $\eta_m$  represents the pump efficiency in slurry service, and  $\eta_w$  is the clear-water equivalent. Likewise,  $P_m$  and  $P_w$  are the power requirements for slurry service and water service, respectively. The head  $H_m$  is developed in slurry service, measured in height of slurry, whereas  $H_w$  represents the head developed in water service in height of water. The head ratio  $H_r$  and the efficiency ratio  $\eta_r$  are defined as  $H_m/H_w$  and  $\eta_m/\eta_w$  respectively. The fractional reduction in head (the head reduction factor) is denoted by  $R_H$  and defined as  $1 - H_r$ ; for efficiency, the fractional reduction (efficiency reduction factor) is  $R_\eta$ , given by  $1 - \eta_r$ .

Test loop results for a large variety of solids at the GIW Hydraulic Testing Laboratory have been put together in a generalized design diagram (Figure 12) for larger heavy-duty pumps and smaller pumps having impeller diameters of 8 in (0.2 m) to 16 in (0.4 m). The diagram gives  $R_H$  and  $H_r$  in terms of pump impeller diameter ( $D$ ) and solid average size ( $d_{50}$ ) at a solids concentration by volume ( $C_v$ ) of 0.15 (15%) with a solids density ratio 2.65 and a negligible amount of fine particles ( $X_f = 0$ ). For example, a pump with an impeller diameter of 32 in (0.81 m),  $R_H$  becomes 14% ( $H_r = 0.86$ ) for a  $d_{50}$  of 0.39 in (10 mm).

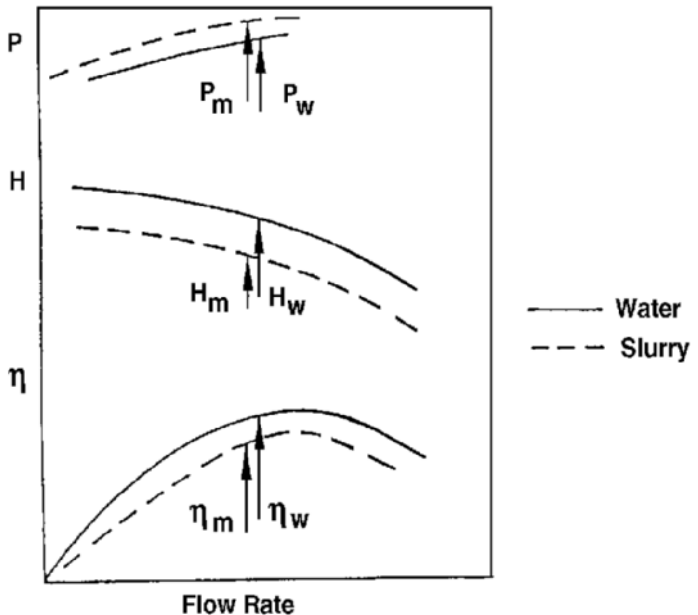
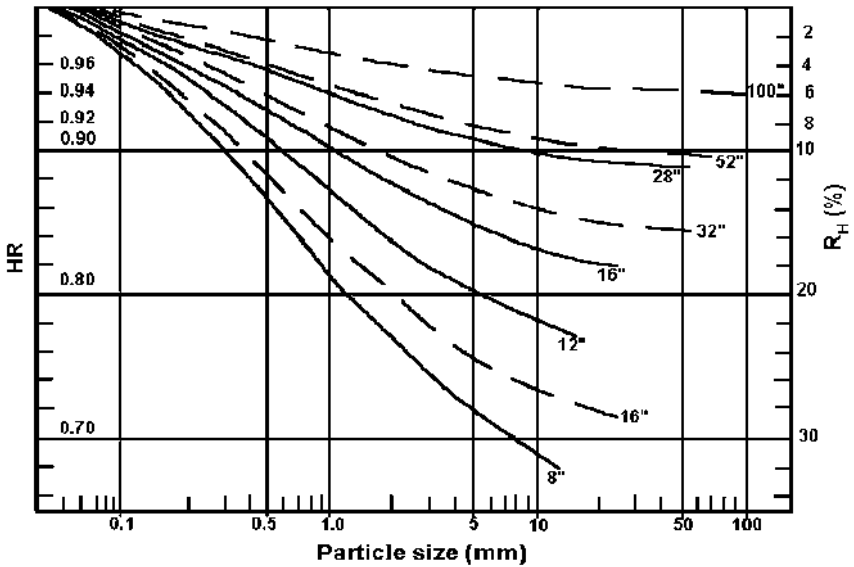


FIGURE 11 Effect of slurry on pump characteristics (schematic)



**FIGURE 12** Effects of particle size ( $d_{50}$  mm) and impeller diameter ( $D$  in) on  $H$ , and  $R_H$ . For solids concentration by volume,  $C = 15\%$  with solids density ratio,  $S_s = 2.65$  and a negligible amount of fine particles ( $X_f = 0$ ). Solid lines represent smaller newer design pumps while dashed lines represent conventional heavy duty pumps. Adapted from GIW Industries Inc., U.S.A. [Note: for particle size in inches, multiply by 0.039; for impeller diameters in mm, multiply inches by 25.4.]

Corrections for various values of  $C_v$ ,  $S_s$ , and  $X_h$  will now be given together with estimations of the reduction in efficiency,  $R_\eta$ . Based on experimental results discussed in Wilson et al. (1997), the  $R_H$  values obtained from Figure 12 may be multiplied by the following factors when the solids density ratio and the fine particle content are different from 2.65 and zero, respectively.

solids density ratio,  $S_s$ : 
$$\left[ \frac{S_s - 1}{1.65} \right]^{0.65}$$

fine particlue content,  $X_h$ : 
$$(1 - X_h)^2$$

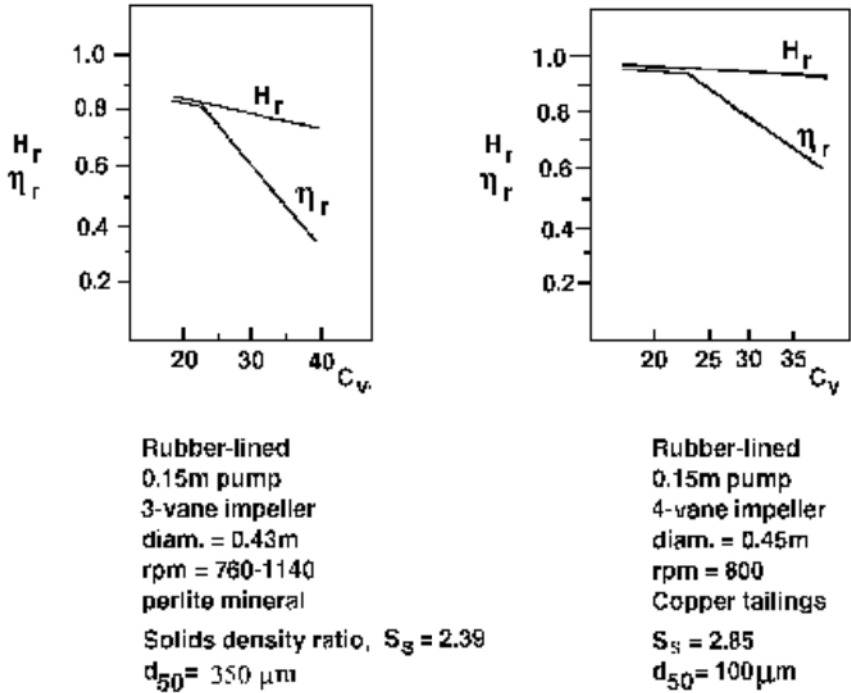
For example, with  $S_s = 4.4$  and  $X_h = 0.08$  (8%), the factors become 1.6 and 0.85, respectively. The pump previously mentioned with an impeller diameter of 36 in (0.91 m) had  $R_H$  of 14%. This value is now corrected to give

$$R_H = 14 (1.6) 0.85 = 19\%$$

$R_H$  can normally be related linearly to  $C_v$ , for cases with  $C_v$  less than 15–20%. Thus with  $C_v = 6\%$  in the previous example,  $R_H$  will be  $19 (6/15) = 8\%$  because the reference value for  $C_v$  in Figure 12 is 15%.

For the larger pumps in Figure 12, the reduction in efficiency,  $R_\eta$ , is normally less than  $R_H$ . For the smaller pumps, with  $D < 16$  in (0.4 m),  $R_\eta$  usually equals  $R_H$ ; however, it may be sensitive to solids properties. Independent of the pump type in Figure 12,  $R_\eta$  may exceed  $R_H$  if  $C_v$  exceeds about 20%, indicated on Figure 13.

In opposition to these tendencies, there have also been investigations where the reduction in efficiency remains small at very high concentrations, specifically with broad particle-size distributions.



**FIGURE 13** Head and efficiency reduction curves for two products (from Sellgren and Vappling, 1986). [Note: for dimensions in inches, divide mm by 25.4 and multiply m by 39.36.]

With equivalent reductions,  $R_H = R_\eta$ , the power consumption increases directly with the relative slurry density.

$$P_m = S_m \cdot P_w \tag{1}$$

with  $R_\eta < R_H$  ( $H_r > \eta_r$ ), Eq. 1 becomes

$$P_m > S_m \cdot P_w$$

that is, the power consumption becomes larger than that given by Eq. 1.

Finally, the calculated reductions may be underestimated if the solid particles are coarse and very angular. For example, the solids used in the preceding examples consisted of crushed angular particles and actually gave reductions in head and efficiency well over 10% (Sellgren et al., 1997), compared to  $R_H = 8\%$  calculated here based on Figure 12.

On the other hand, with very fine particles, or large  $X_h$ -values and high solids concentrations, most slurries are practically nonsettling. In this case, the solids effect is mainly related to the rheological behavior. When pumping nonsettling slurries in industrial applications, the slurry normally behaves in a non-Newtonian way, giving widely varied pump performance effects. In general, however, small pumps are affected more than large units when pumping highly viscous or non-Newtonian media. Furthermore, the influence on the efficiency is normally larger than on the head.

Occasionally, highly non-Newtonian slurries may be pumped by centrifugal pumps operating at flow rates much lower than the maximum-efficiency value  $Q_{BEP}$ . This may cause a dramatic drop in head, which creates an unstable head curve, seen for example in Figure 14.

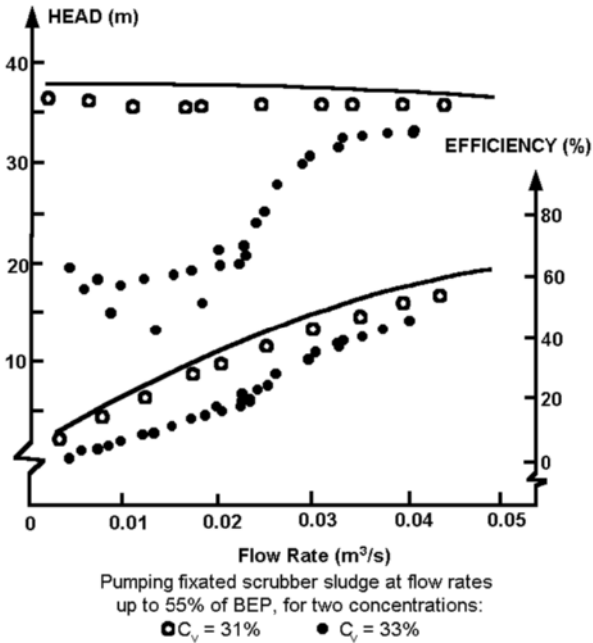


FIGURE 14 Effect of highly non-Newtonian slurries on pump head and efficiency (from Sellgren et al., 1997). [Note: for flow rate in gpm, multiply m³/s by 15,850; for head in ft, multiply m by 3.28.]

**WEAR MECHANISMS AND MATERIALS**

As noted earlier, wear in a slurry pump can be severe. It is not possible, therefore, to use normal cast iron or other materials. Ideally, the life of components should be a year or more. In practice, even with the best design and materials, it can sometimes be as low as a month. Understanding wear and using the correct materials is key in the design of a slurry pump. The major erosive mechanisms are sliding abrasion and particle impact. The sliding-abrasion mode of wear typically involves a bed of contact-load particles bearing against a surface and moving tangentially to it, as illustrated in Figure 15. In pipelines,

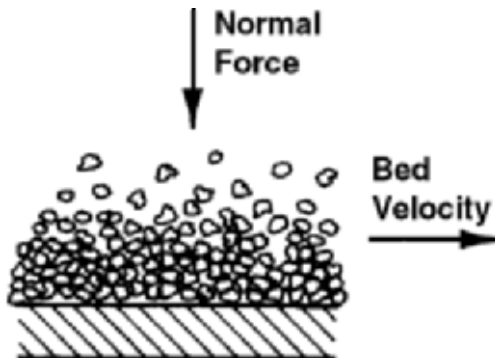


FIGURE 15 Erosion by sliding abrasion

the stress normal to the surface is caused by gravity. For sliding abrasion, the erosion rate depends on the properties of particles and wear surfaces, the normal stress, and the relative velocity.

The normal stress is enhanced when the flow streamlines are curved, as in a pump casing. In this case there is a centrifugal acceleration, equal to  $u^2/r$ , where  $u$  is the local velocity and  $r$  is the radius of curvature of the streamlines. This acceleration can often be much greater than that of gravity, producing a commensurate increase in the normal stress between the moving contact-load solids and the wall material, and hence a greatly increased rate of sliding-abrasion wear. This type of behavior can cause a pump casing to wear through when adjacent straight-pipe sections of the same material have hardly been affected by erosion. Near the tongue of the pump casing, however, the other major wear type is more significant.

The second type of wear is the particle-impact mode, which occurs where individual particles strike the wearing surface at an angle, despite the fact that the fluid component of the slurry is moving along the surface (Figure 16). Removal of material over time occurs through small-scale deformation, cutting, fatigue cracking, or a combination of these, and thus depends on the properties of both the wearing surface and the particles. Ductile materials tend to exhibit erosion primarily by deformation and cutting, with the specific type depending on the angularity of the eroding particles. Brittle or hardened materials tend to exhibit fatigue-cracking erosion under repeated particle impacts. For a given slurry, the erosion rate depends on properties of the wearing surface: hardness, ductility, toughness, and microstructure. The mean impact velocity and mean angle of impact of the solids are also important variables, as are particle characteristics such as size, shape, and hardness, and the concentration of solids near the surface.

As wear mechanisms vary considerably, so also do the engineering materials that resist them. A survey of all the available wear-resistant materials and their applications would provide subject matter for a volume in itself. Nevertheless, there are a few groups of materials that have found widespread successful application against erosion in slurry systems, and thus merit particular attention. These materials fall into the broad categories of hardened metals, elastomers (rubbers and urethanes), and ceramics. Materials in each of these

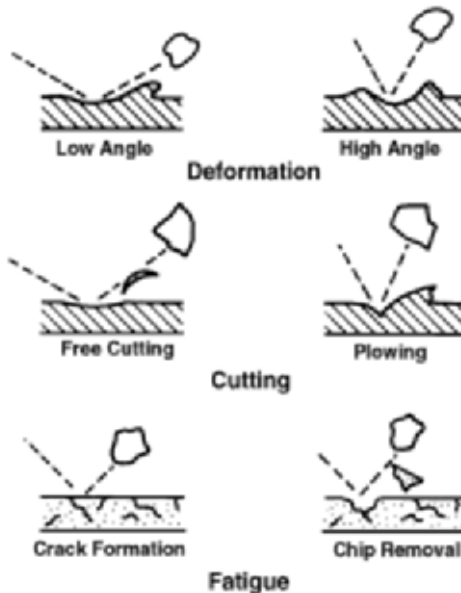


FIGURE 16 Mechanisms of particle-impact erosion

categories have their advantages and disadvantages, and the final choice of a material must account for wear resistance, strength, ease of maintenance, direct cost, and indirect costs such as plant downtime for maintenance, or failure, safety of operation, and effect on system efficiency.

Within the metals group, superior wear resistance is given by the high-alloy white cast irons, particularly nickel-chrome (for example, NiHard), chromemoly (for example, 15% chromium and 2% molybdenum), and high chrome (for example, 27% chromium) alloys. These materials exhibit higher hardness (600 plus Brinell), but less toughness than steel alloys of similar tensile strength. The high carbon content and resultant massive carbides present in these metals gives them excellent resistance to all forms of particle erosion, especially in sliding or impact at low angles (cases often encountered in slurry applications). For the coarsest slurries, hard metal is common, principally the so-called NiHard, high-chrome, or chrome-molybdenum alloys of 600–700 Brinell hardness.

For slurries without coarse particles, elastomers such as rubber, neoprene, and urethane tend to wear better than hard metal, especially for liners and shells. This improvement applies only if there is no “tramp” (that is, extraneous material such as tools, bolts, or pieces of broken castings). Elastomer selection may also be determined by the corrosive characteristics of the slurry. Natural soft rubber remains an excellent and economical pump lining material to handle fine abrasive and corrosive slurries. Carbon black can be added for additional strength, hardness, and tear resistance, to better withstand the impact of large particles in the slurry. Like all other materials, rubber has limitations that should be considered in the selection process. Wear rates in the presence of coarse material or high tip speeds may make it uneconomical, and tramp material or adverse suction conditions can tear the rubber. High temperature or the presence of oils or chemicals may require the use of one of the higher-cost synthetic materials. For example, neoprene has been found to tolerate higher temperatures and higher impeller tip speeds than can be used with natural rubber.

## **CALCULATION OF SLURRY PUMP WEAR**

---

The general selection rules noted earlier aim at keeping wear to generally acceptable levels, but are otherwise non-quantitative. Finite element and other methods such as those described by Addie et al. (1996) or Pagalthivarthi (1991) are now available. They allow particle velocities inside a pump to be calculated, which, using material wear tests coefficients as described by Pagalthivarthi (1990), can be used to determine wear rates and component lives.

For example, numerical simulations allow calculation of wear around the periphery of a given pump shell for a given set of conditions. Figure 17 is an example of how wear varies with different flows from Roco et al (1983). Addie et al. (1987) shows also how a particular collector can be altered and optimized for the best possible wear.

Modeling methods of calculating wear inside a slurry pump impeller and in the nose sealing face area are also being developed so in the near future it will be possible to evaluate the wear of the complete pump in a given application. Although all of these methods cannot predict three-dimensional turbulent wear, they are now opening up the possibility of better designs, better selection, and the calculation and evaluation of the total cost of ownership, Addie et al (1998), and the benefits that could come from that.

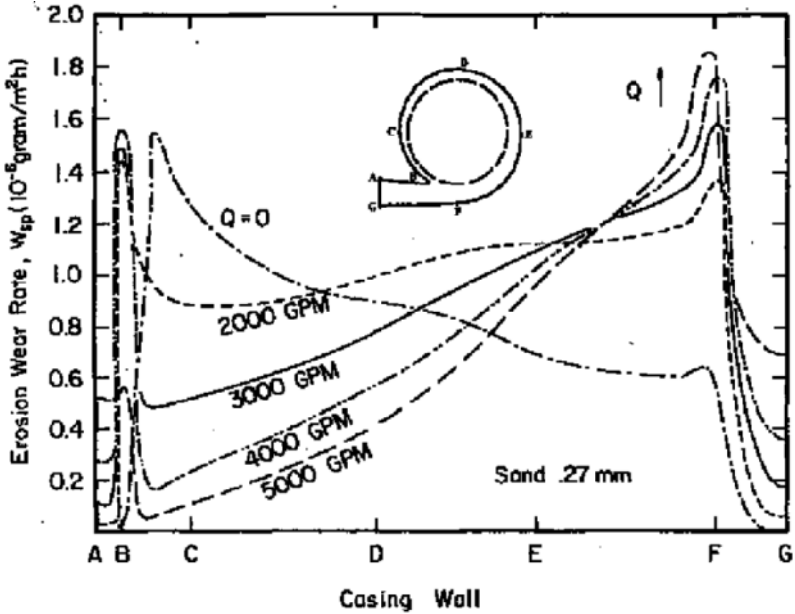


FIGURE 17 Erosion wear distributions calculated at different flow rates. [Note: for flow in l/m, multiply gpm by 3.79; for particle size in inches, divide mm by 25.4.]

## REFERENCES

- Addie, G. R., and Helmlly, F. W. (1989). Recent Improvements in Dredge Pump Efficiencies and Suction Performances. *Proc. CEDA Dredging Day*, Amsterdam.
- Addie, Graeme R., Pagalthivarthi, K. V., and Visintainer, R. J. (1996). Centrifugal Slurry Pump Wear, Technology, and Field Experience. *Proc. ASME Fluids Meeting*, San Diego, CA, pp. 703–716.
- Addie, Graeme R., and Carlson, R. R. (1998). Tools and Technology for Selecting Slurry Pumps. *CIM Montreal '98*.
- Addie, G. R., Visintainer, R. J., and Roco, M. C. (1987). Experiences with a Numerical Method of Calculating Slurry Pump Casing Wear. *Proc. 4th International Pump Symposium and Short Courses*.
- Cooper, Paul, et al. (1987). Centrifugal Slurry Pump Wear and Hydraulic Studies. Report, Ingersoll-Rand Company for U.S. Department of Energy Office of Fossil Energy and Pittsburgh Energy Technology Center. DE-AC22–82PC50035.
- Kasztejna, P. J., et al. (1986). Hydraulic Development of Centrifugal Pumps for Coal Slurry Service. *Proc. 8th International Symposium on Coal Slurry Fuels Preparation and Utilization*, pp. 646–665.
- Maciejewski, et al. (1993). Transport of coarse rock with sand and clay slurries, *Proc. Hydrotransport 12*, BHRA Fluid Engineering, Cranfield, UK, pp. 705–741.
- Pagalthivarthi, K. V., and Helmlly, H. W. (1990). Application of Materials Wear Testing to Solids Transport via Centrifugal Slurry Pumps. *Wear Testing of Advanced Materials, ASTM STP 1167*, Divakar and Blau, eds. American Society for Testing Materials, Philadelphia, PA.

- Pagalthivarthi, K. V., Desai, P. V., and Addie, G. R. (1991). Quasi-3D Computation of Turbulent Flow in Centrifugal Pump Casings. *Proc. ASME Symposium on Multidisciplinary Application of CFD*.
- Roco, M. C., and Addie, G. R. (1983). Analytical Model and Experimental Studies on Slurry Flow and Erosion in Pump Casings. *Proc. 8th International Conf. Technology*. Slurry Transportation Association, p. 263.
- Sellgren, A., and Addie, G. (1993). Solids effects on the characteristics of centrifugal slurry pumps. *Proc. 12th International Conference on the Hydraulic Transport of Solids in Pipes*, Brugge, Belgium, pp. 3–18.
- Sellgren A., and Addie, G. (1996). Pump and pipeline solids effects of transporting sands with different size distributions and concentrations. *Proc. 13th International Conference on the Hydraulic Transport of Solids in Pipes*, Johannesburg, South Africa, pp. 227–236.
- Sellgren, A., and Vappling, L. (1986). Effects of Highly Concentrated Slurries on the Performance of Centrifugal Pumps. *Proc. International Symposium on Slurry Flows*, FED Vol. 38, ASME, USA, pp. 143–148, 1986.
- Sellgren, A., Addie, G., and Wei-chung, Y. (1997). Effect of Coarse and Heavy Solid Particles on Centrifugal Pumps Head and Efficiency. *47th Canadian Chemical Engineering Conference*, Edmonton, AB.
- Wilson, K. C., Addie, G. R., Sellgren, A., and Clift R. (1997). *Slurry Transport Using Centrifugal Pump*, 2nd edition. Blackie Academic and Professional, London.



# 9.16.3 CONSTRUCTION OF SOLIDS- HANDLING DISPLACEMENT PUMPS

WILL SMITH

## APPLICATIONS

---

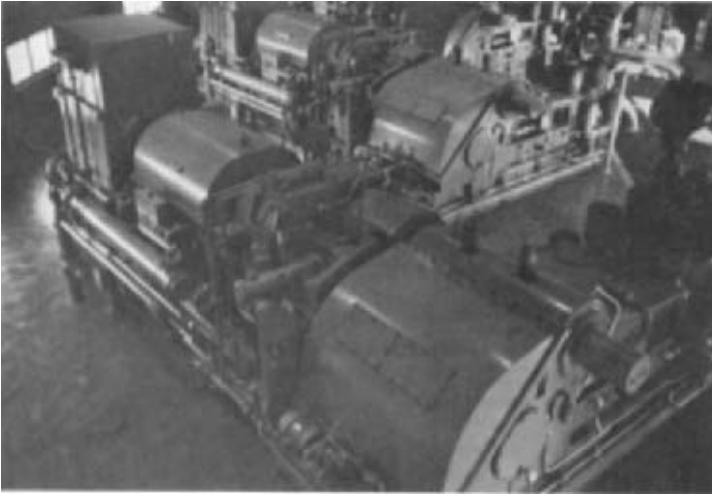
Positive displacement pumps are especially suited for many solids-pumping applications because constant high pressures and good efficiency are achieved over the full range of pump capacities. Low relative velocities between abrasive liquid-solids mixtures and the pump parts minimize erosion. With centrifugal pumps, an increase in system resistance, such as a flow blockage caused by settled solids or the apparent viscosity increase characteristic of many slurries due to momentary capacity reduction, results in a self-defeating reduction in pump flow rate.

Positive displacement pumps are popular for a number of solids-handling applications. Each application presents peculiar demands for pump features.

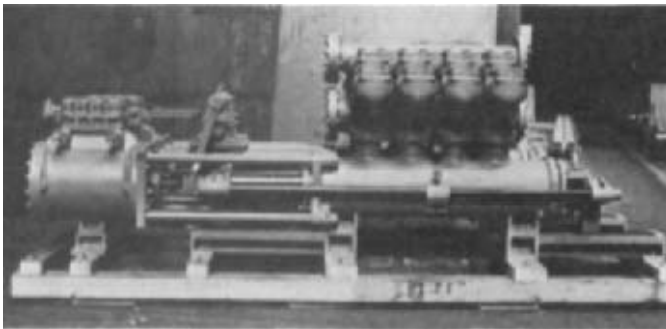
**Solids Transport** Large-capacity positive displacement pumps at moderate pressures are used to pump coal and ores over relatively long distances. Solids for transport are usually slurried with water and are pumped at ambient temperatures. Double-acting horizontal piston pumps with large, “mud pump” valves and piston rings (Figure 1) typify transport service.

Most pipelines have multiple pumping stations at intervals along the route, dictated by topography and by pipeline and pumping station first and operating cost balances. Centrifugal booster pumps are employed at the first station to deliver the prepared slurry to the displacement pumps at a sufficient pressure to satisfy their *NPSH*, including acceleration head, requirement. Subsequent stations are located at points where there is sufficient residual pipeline pressure to fulfill the displacement pump's suction requirements. The capacity of each station is adjusted by pump speed control so the next station's inlet pressure is kept relatively constant.

Most stations muse multiple positive displacement pumps in parallel, with at least one standby pump. Capacity modulation requires but one of the pumps to be operating with



**FIGURE 1** Horizontal double-acting duplex coal slurry pipeline pumps (Black Mesa Pipeline, Oil Well Div. of U.S. Steel)



**FIGURE 2** Horizontal double-acting plunger pump for slurry of grain mash and water for alcohol production (Flowserve Corporation)

speed control, although all are generally so fitted. Unlike centrifugal pumps, displacement pumps can provide full rated pressures at all speed-controlled capacities.

**Process Pumping** Some chemical and petroleum processes require pumping of solids to high pressures for process reactions. Typical of these are bauxite ore in hot caustic for alumina plants, ground coal in water or coal liquids for synthetic fuel production, and grain in water for alcohol production (Figure 2).

Process streams involve a vast variety of liquids and solids. Concentrations may be as high as 70% solids by weight. Temperatures can reach 800°F (427°C). Pressures from several hundred to many thousands of pounds per square inch are accommodated.

**Other Specialty Services** A number of specialty services employ positive displacement pumps to handle solids. Some are relatively simple applications of standard catalog pumps, and others are single-purpose developments and thus have evolved with unique characteristics.

*Mud pumps* are used to inject drilling mud, which transports cuttings out of wells and lubricates the drill bit during well drilling. Because of the limited duration of a drilling project, the life of expendable parts (packing, valves, rods) is compromised in favor of size and weight for portability and ease of overhaul. *Sludge disposal pumps* are common in sewerage treatment plants, and *tailings pumps* move solids out of mines.

## PUMP CONSTRUCTION

---

Solids-handling displacement pumps differ from ordinary displacement pumps in the means used to alleviate the deleterious effects of the solids on the packing, the displacement element (whether plunger, piston, or diaphragm), and the suction and discharge check valves. To protect parts from the ravages of the solids, (1) particles are prevented from entering close clearances, (2) operation is at lower speeds to reduce the effects of erosion and abrasion, or (3) the susceptible parts are made of wear-resistant materials. Because sacrificial wear parts must be replaced more often than in clear liquid pumps, special design attention for ease of replacement of these parts is justified.

The designer's choice is between hard materials that resist wear and resilient materials that may accommodate the particles of solids. This choice is often limited by other factors, such as temperature and chemical compatibilities. Hard materials used include

- Tungsten carbide
- Ceramics—chrome oxide and aluminum oxide
- Hardenable stainless steel
- Cobalt-nickel alloys

Some common soft materials are

- Synthetic elastomers
- Softer metals (sacrificial)

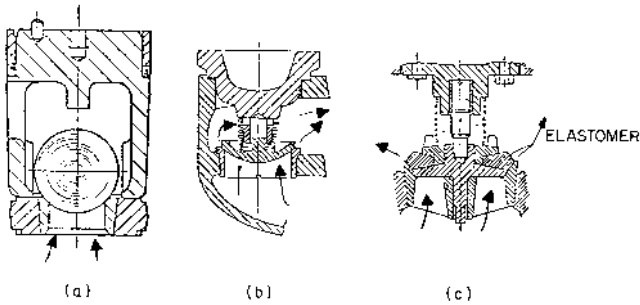
Unlike centrifugal pumps, positive displacement pumps are more prone to abrasive than erosive wear. This is due to the much lower relative velocities between the liquid and the pump parts. Centrifugal pumps must generate high relative velocities, typically greater than 100 ft/s (30 m/s), for the dynamic specific energy that is converted to discharge pressure. Positive displacement pump velocities are kept low, limited usually by the settling velocity of the slurry, which is on the order of less than 10 ft/s (3 m/s).

There are four types of positive displacement solids-handling pumps:

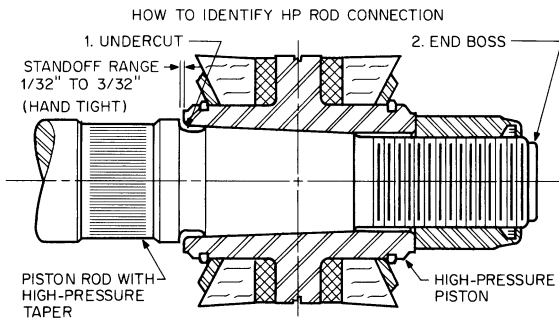
1. Reciprocating piston pumps
2. Reciprocating plunger pumps
3. Diaphragm pumps
4. Hydraulic displacement pumps

**Valves** Common to all types are suction and discharge check valves, the purpose of which is to allow the solids-laden liquid to flow into the pump from the suction line and into the discharge line from the pumping chamber while preventing backflow. The features of slurry valves include

1. Large areas for low flow velocity
2. Smooth, unobstructed passages to avoid trapping and build-up of solids
3. Special designs to enhance sealing against pressure in the closed position
4. Special materials to minimize wear



**FIGURE 3A through C** Three types of slurry valves: (a) free-floating ball valve, (b) spring-loaded spherical (Rollo) valve, (c) spring-loaded elastomer-seal (mud) valve



**FIGURE 4** Double-acting mud pump piston. Standoff range varies between 0.030 to 0.090 in (0.75 to 2.25 mm).

Figure 3 illustrates some valves developed particularly for solids-handling pumps. Which valve is selected for a particular application depends on the abrasiveness, viscosity, temperature, solids size, and uniformity of the slurry. It is important that the valve lift be sufficient to pass the largest particles of solids expected. Adequate sealing in the closed position is necessary to avoid excessive back leakage, which detracts from the volumetric efficiency of the pump.

Valve materials must meet temperature, corrosion, abrasion, and mechanical strength requirements. Materials for valves and seats range from cast iron and bronze through hardenable stainless steels to solid tungsten carbide. The cost of replacement or refurbishment over the expected life, including labor and downtime, should be balanced against first cost.

**Packing Protection** A distinguishing feature of solids-handling displacement pumps is the means used to avoid or minimize packing wear. Five different approaches are

1. Use of conventional designs with special materials and operation at less demanding conditions, such as reduced speeds
2. Provision of a clean nonslurry environment for the packing rubbing surfaces
3. Separation of the slurry from the displacement element
4. Separation of the slurry from the pumping element
5. Total isolation of the slurry from the packing

**CONVENTIONAL DESIGN WITH MODIFIED OPERATION** Piston pumps usually fall into this category. By using larger pumps at speeds that are lower than those normally found with clear fluids, velocity-sensitive wear rates are reduced. *Special piston rings* (Figure 4) are used

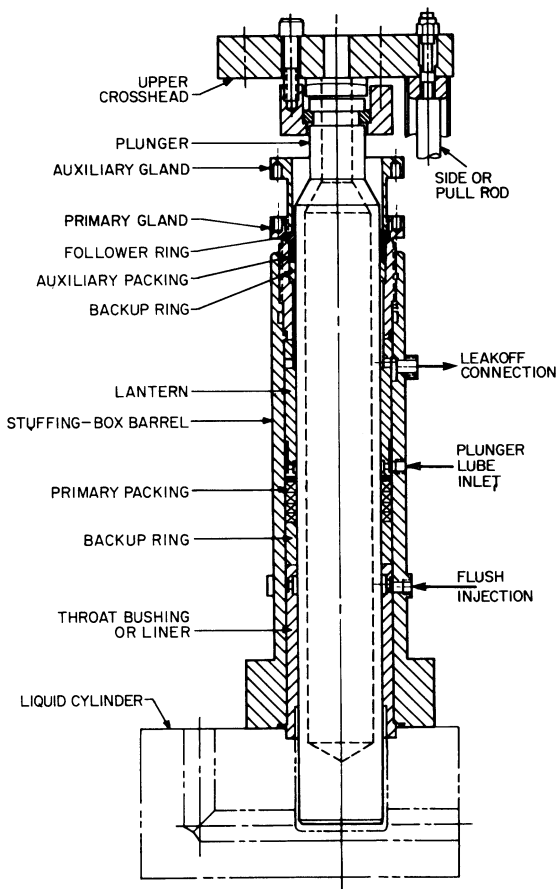
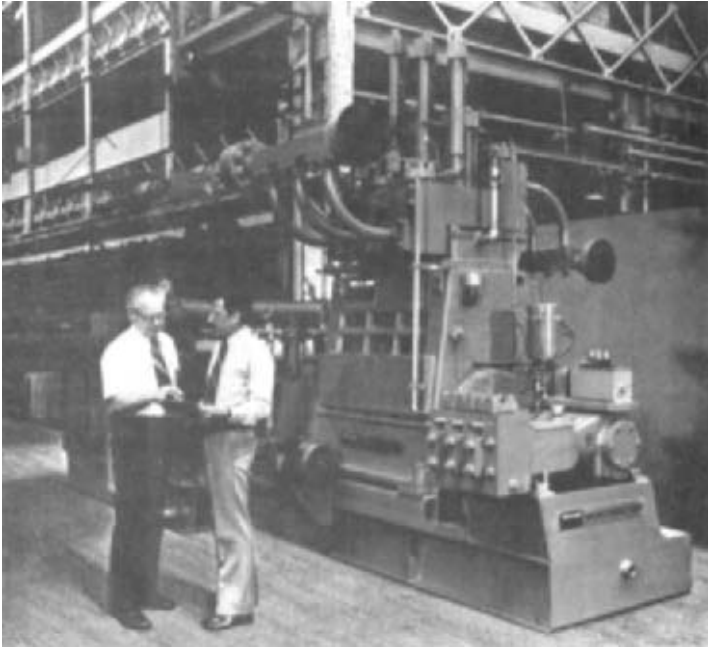


FIGURE 5 Typical flush injection

that tend to resist abrasion because they are made of zero clearance elastomeric materials and designed to scrape clean the cylinder wall. Such piston packing is a normal wear item and must be replaced at regular intervals.

**CLEAN NONSLURRY ENVIRONMENT** This is accomplished by the injection of clear liquid (Figure 5). Such injection may be either *continuous* or *synchronized* with the stroke of the plunger or piston. When effectively accomplished, flush injection presents essentially clear pumpage to the packing so it attains normal clear liquid packing life. Flush liquid that enters the pumping chamber dilutes the pumpage and decreases the suction volumetric efficiency.

Clear, compatible flush liquid may be scarce or expensive. Therefore special stuffing box plus flush injection systems have been developed. Required flush rates are a function of pump type and size and system employed. Satisfactory operation has been attained with flush rates of about 2 to 5% of pumped flow and even less for very large pumps. If other than a positive displacement flush pump is used, flush flow will increase as packing and throat bushings wear.



**FIGURE 6** Vertical single-acting triplex plunger pump with synchronized flush liquid injection (Flowsolve Corporation)

Flushing prevents incursion of slurry particles by providing a liquid velocity counter to the unwanted slurry flow in clearances and by washing solids particles from the plunger or rod surfaces as they move toward the packing. Injection systems may be as simple as a constant-pressure liquid fed to a point between the packing and the throat bushing or as complex as a sophisticated synchronized injection system involving an additional positive displacement pump driven directly from the slurry pump drive train and independently furnishing a definite quantity of flush fluid to each plunger or piston during each pump stroke (Figure 6).

Combinations of positive, independent, synchronized pumped injection, and auxiliary buffer liquids have been proposed for very special situations.

**SEPARATION OF SLURRY FROM DISPLACEMENT ELEMENT** One means of reducing the concentration and temperature of slurry at the pump packing is the use of a liquid, or surge, leg (Figure 7). The displacement element—plunger or piston—is separated from the suction and discharge valves by a length of pipe that is filled with clear liquid. This liquid leg communicates with the valve chambers such that, as the liquid ebbs and flows in response to the motion of the displacement element, it acts as a liquid piston, inducing and then expelling slurry through the suction and discharge valves. Make-up liquid is injected into the surge leg, preferably through a throat bushing isolating the displacement chamber from the packing so there is theoretical flow away from the stuffing box. The surge leg thus offers the packing some degree of protection from the solids and from thermal effects.

Surge legs are, however, subject to the complete span of suction-to-discharge pressure change on each stroke. Therefore they must be designed for endurance fatigue loading. When high-temperature isolation is involved, thermal expansion and contraction must also be considered. Although surge leg pumps have been demonstrated to increase piston or plunger packing life, they do not totally prevent solids migration from the pumping

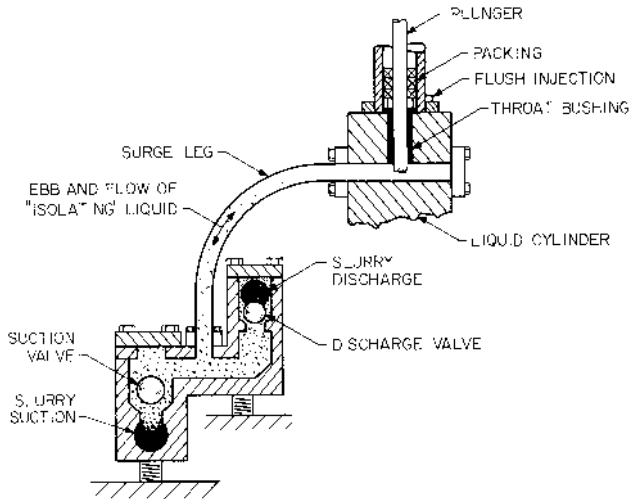


FIGURE 7 Surge leg plunger pump

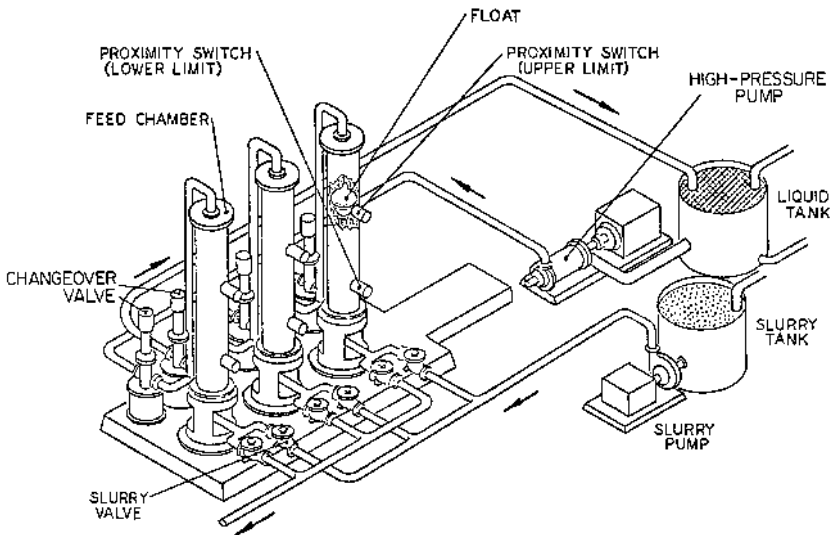


FIGURE 8 Large, low-cycle chamber feeders separate the high-pressure pumping element from the slurry (Hitachi)

chamber. Therefore special construction materials, flush injection, and reduced speeds are still appropriate.

**SEPARATION OF SLURRY FROM PUMPING ELEMENT** A special case of the liquid leg pump is the large, low-cycle chamber feeder (Figure 8). Although these units may or may not properly qualify as positive displacement pumps (because the motivating liquid may be delivered by a centrifugal pump), they do nevertheless have much in common with surge leg pumps.

The motivating liquid is pumped into a chamber and displaces a charge of slurry through suitable check valves. The chamber may have a moving separation barrier between the motivating and motivated liquids. When the slurry is expelled, controls cause valves to reverse the flow, filling the chamber again with slurry while voiding it of the clear liquid. By employing two or more chambers, a virtually continuous flow of slurry is obtained. Advantages of this scheme are the extra-low frequency of check valve operation, low slurry velocities, and high capacities. Centrifugal, positive displacement, or even compressed gas pumps can be used for motivation. Because the motivation pump is independent of the slurry system, it can operate at normal speed.

Two disadvantages of chamber feeders are their dependence on controls and switching valves in addition to the slurry valves and the fact that the systems are large.

**TOTAL ISOLATION** Many types of diaphragm pumps that completely separate the slurry from the running gear of the pump have been designed (Figure 9). Because the separating diaphragm is wetted on one side by the slurry, it is vulnerable to the mechanical, chemical, and thermal abuse that might otherwise apply to pistons, plungers, packing, and so on. Of course, the diaphragm is also subjected to full reversal loads and must be designed for fatigue life. Both elastomeric and metallic diaphragms have been used.

The severity of diaphragm failure problems has been alleviated somewhat in some designs that employ double diaphragms with intervening barrier liquids. The thesis is that there is a much reduced probability of both diaphragms failing before detection and repair.

## DIAGNOSTIC SYSTEMS

Diagnostic monitoring of vibration, pressure pulsations, speed, flow rate, temperatures, and pressures may be applied to these pumps as well as other large machines. Such monitoring is relevant to slurry pumps because of the necessity to replace worn parts more frequently than is the case with clear-liquid pumps. Designers and users of displacement pumps for handling solids should consider using available monitoring equipment as an aid to maintenance and as a means to ensure the safety of personnel by warning of imminent failure. Vibration signatures are readily obtained from sensors placed in critical locations on the pump, and this information can be valuable in assessing the operating integrity of the pump. To this should be added valve wear detection, as would be indicated by a difference between the expected flow rate at the speed involved and the actual flow rate. In addition, proximity probes and vibration sensors could be used to monitor wear of plungers, piston rods, bearings, and crossheads.

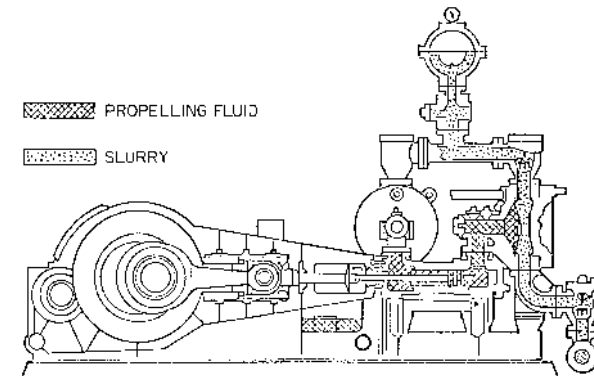


FIGURE 9 Diaphragm pump isolates slurry from packing (Geho)



---

# SECTION 9.17

---

# OIL WELLS

---

JOHN R. BRENNAN  
WILLIAM M. VANCE

## **ARTIFICIAL LIFT OF OIL WELLS**

---

Oil wells can range in depth from approximately 200 ft (60 m) to more than 20,000 ft (6000 m). They require pumps that are unique in their configuration. About 90% of pumping oil wells are equipped with either 2-in (50.8-mm) or  $2\frac{7}{16}$  in (61.9-mm) ID tubing. Sucker rod pumps, hydraulic reciprocating pumps, or hydraulic jet pumps that must run inside this tubing cannot have their outside diameters exceed  $1\frac{7}{8}$  in (47.6 mm) or  $2\frac{5}{16}$  in (58.7 mm). These pumps are installed as close as possible to the bottom in order to achieve the maximum possible drawdown of fluid in the well. The output pressure required of the pump varies directly with the depth that the fluid must be lifted. For example, to compensate for the lift required and the fluid friction in the tubing, a 10,000-ft (3049-m) well might require a 4000-lb/in<sup>2</sup> (276-bar<sup>o</sup>) pump.

In a newly discovered field, wells will usually flow of their own accord and require no artificial lift. The volume from these wells is controlled by holding back pressure at the wellhead with a choke. The annulus between the production tubing and the oil well casing is closed off at the wellhead; thus all of the gas produced by the well flows up the production tubing with the oil. When the bottom hole pressure is no longer adequate to produce the well by natural flow, some form of artificial lift must be installed. This can be a sucker rod pump, a subsurface hydraulic reciprocating pump, a subsurface hydraulic jet pump, an electric submersible centrifugal pump, or a gas lift. The sucker rod pump is by far the most common form of artificial lift. More than 80% of the wells that must be artificially lifted are pumped with sucker rod pumps.

## THE SUCKER ROD PUMPING SYSTEM

---

The sucker rod pumping system consists of a prime mover, a pumping unit, a polished rod with a stuffing box to seal off the pumped fluid pressure at the surface of the well, and a sucker rod string to transmit the reciprocating movement from the pumping unit to the sucker rod pump. The pumping unit is the mechanism that converts the rotary movement of the prime mover to the reciprocating movement needed to power the sucker rod pump. The sucker rod string consists of individual sucker rods of 25- or 30-ft (7.6- or 9.1-m) lengths that are connected with couplings when they are lowered into the well. This total length of rods connects the surface polished rod to the pump at the bottom and is called the sucker rod string. The complete sucker rod pumping system is illustrated in Figure 1.

The operation of a sucker rod pump is illustrated in Figure 2. The pump is submerged in fluid near the bottom of the oil well. As the sucker rod string and plunger make an upstroke, fluid from the well bore flows past the standing valve into the pump barrel. Also on this upstroke, the traveling valve is closed and the fluid above the plunger is pumped up the annulus between the sucker rod string and the tubing string. On the downstroke, the traveling valve is open and the standing valve is closed. The fluid in the pumping chamber between the traveling valve and standing valve is displaced into the annulus between the tubing and the sucker rod string above the plunger. The fluid in the annulus is lifted toward the surface only on the upstroke.

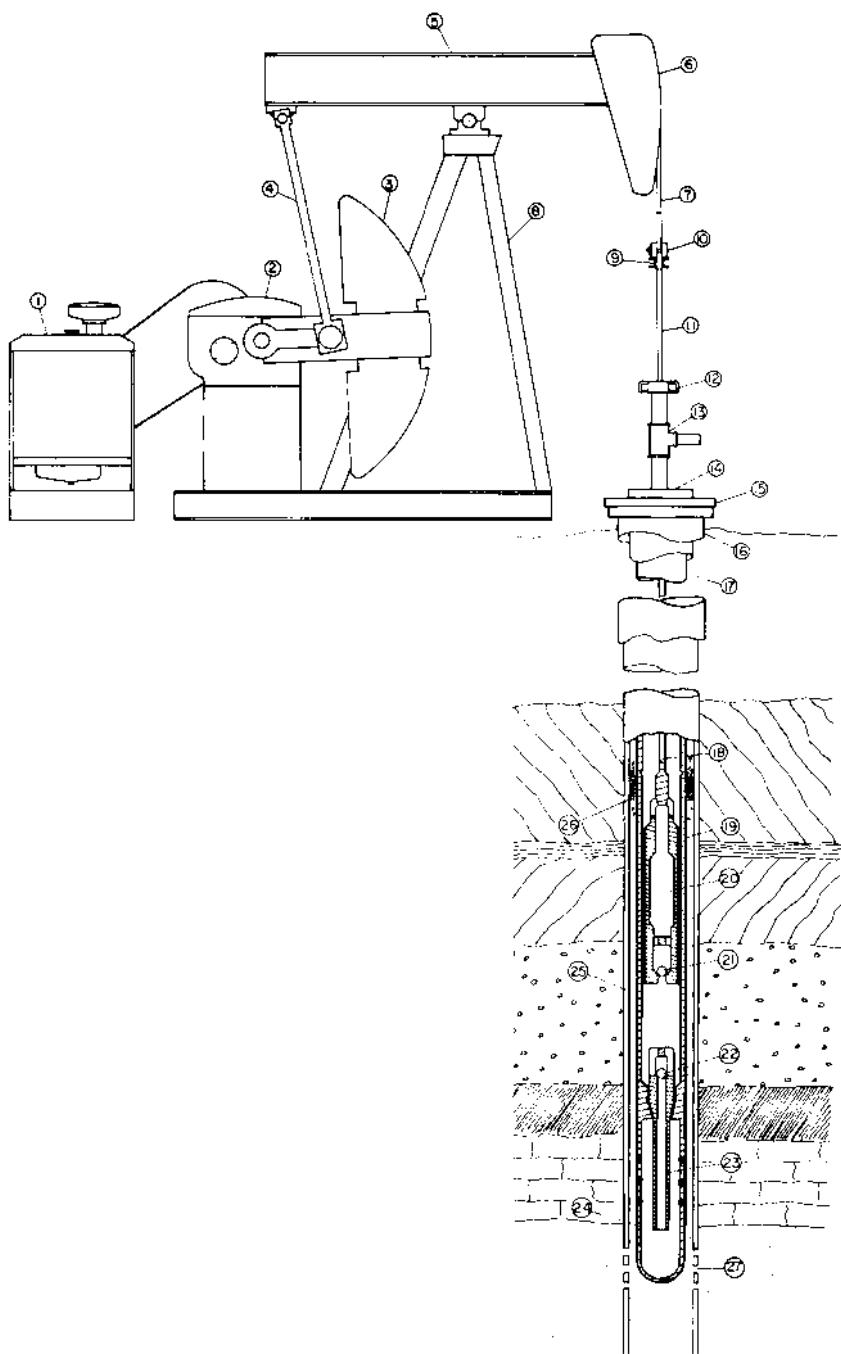
**The Sucker Rod Pump** The principal parts of the sucker rod pump are the barrel, plunger, traveling valve, and standing valve. These are seen in a cutaway section in Figure 3. In shallow wells relatively free of sand, soft-packed plungers are frequently used. These have a number of fabric rings or cups that are expanded by the pumping pressure to a close fit with the barrel. In deep wells or in hard-to-pump shallow wells, the precision-fit metal barrel and plunger as shown in Figure 3 are used. The most common precision barrel is made from steel tubing with a case-hardened or induction-hardened inside wear surface. The inside diameter of the barrel is honed to the nominal bore size with a tolerance of  $\pm 0.001$  in (0.025 mm). Premium barrels are chrome-plated on the inside diameter to a thickness of 0.003 in (0.076 mm) per side. Material for these barrels may be carbon or stainless steel, brass or Monel. The brass or Monel tubes are used when hydrogen sulfide, carbon dioxide, and brine mixed with produced fluid create an extremely corrosive condition. More common barrel lengths range from 5 to 24 ft (1.5 to 7.3 m), but longer lengths are available for use with very long-stroke surface units.

There are several kinds of plungers. A chrome-plated one-piece plunger or a plunger made of hard cast alloy iron sections assembled over a steel plunger tube is usually used with the precision hardened steel barrel. A plunger that is hard-faced with a nickel-based spray metal material is usually used with the chrome-lined barrel, although the cast plunger can also be used there. Plungers range from 2 to 6 ft (0.6 to 1.8 m) in length, depending on the depth of the well. These plungers are all ground to a precision tolerance of  $+ 0.0000$ ,  $-0.0005$  in ( $+0.000$ ,  $-0.013$  mm). The diametral fit between the inside of the barrel and the outside of the plunger ranges from 0.002 to 0.005 in (0.05 to 0.13 mm), depending on the quality of the well fluid and the diameter and length of the plunger.

The traveling valve and standing valve of the pump are simple ball-and-seat check valves. Type 440 hardened stainless steel materials are the most common, but in corrosive wells, a cobalt-chromium-tungsten alloy is frequently used, and in very abrasive wells tungsten carbide seats and balls are used.

**Sucker Rods** Sucker rods are manufactured from carbon or low-alloy steel. Table 1 lists the properties of the grades of rod used most frequently. Most sucker rods are manufactured in 25-ft (7.62-m) lengths, but a few areas use 30-ft (9.14-m) lengths. Both ends of the rods are upset\* and externally threaded (Figure 4). The upset ends also have a square for wrenching. Internally threaded couplings are used for connecting rods to make the

\*In oil field terminology, an upset is an enlarged portion formed on the end of the rod by forging. This allows for a joint that is stronger than the body of the rod.



**FIGURE 1** Sucker rod pumping system: (1) prime mover, (2) gear reducer (3) crank and counterweight, (4) pitman, (5) walking beam, (6) horsehead, (7) bridle, (8) Samson post, (9) carrier bar, (10) polished rod clamp, (11) polished rod, (12) stuffing box, (13) pumping tee, (14) tubing ring, (15) casing head, (16) casing surface string, (17) tubing string, (18) sucker rod, (19) pump barrel, (20) pump plunger, (21) traveling valve, (22) standing valve, (23) mosquito bill, (24) gas anchor, (25) casing oil string, (26) fluid level, (27) casing perforations (National Supply)

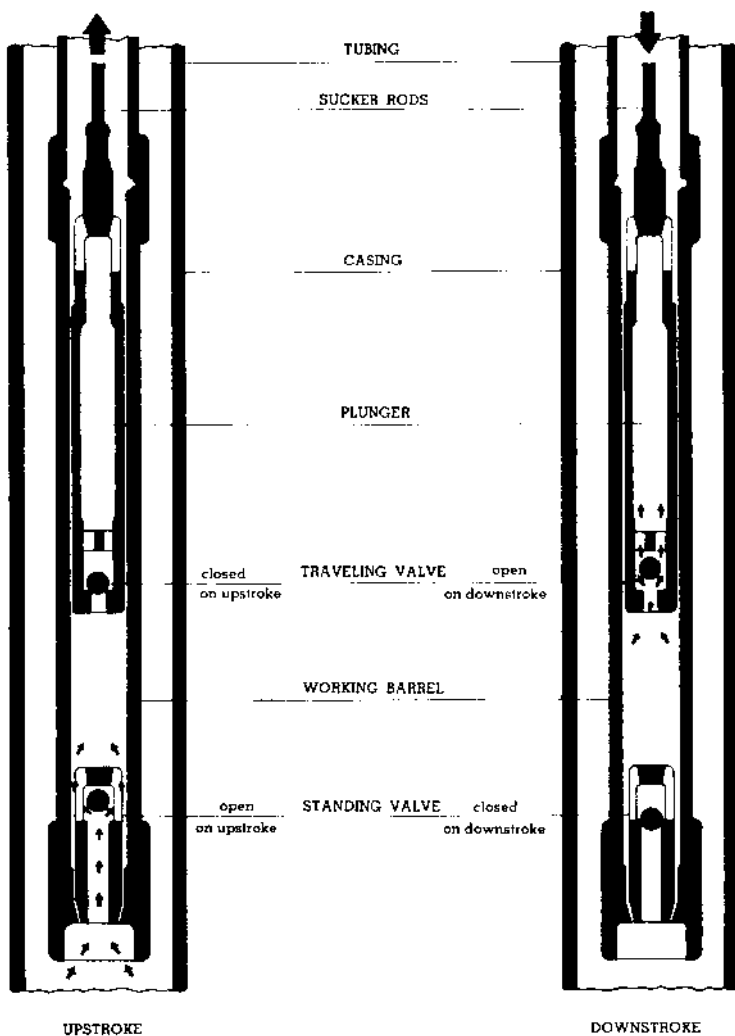


FIGURE 2 Operation of a tubing pump

TABLE 1 Mechanical properties of sucker rods

API class	AISI steel	Yield point, 1000 lb/in <sup>2</sup> (MPa)	Tensile strength, 1000 lb/in <sup>2</sup> (MPa)	Brinell hardness	Heat treatment
C	1036	60–75 (414–517)	90–105 (621–724)	190–205	Normalized
M	4621	68–80 (469–552)	85–100 (586–689)	175–207	Normalized and tempered
D	4142	100–115 (689–793)	115–140 (793–965)	240–280	Normalized and tempered



FIGURE 3 Sucker rod pump

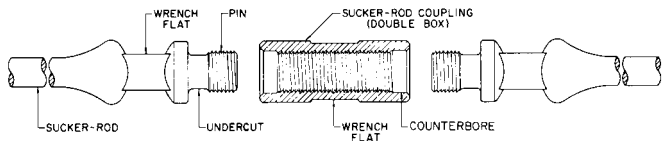


FIGURE 4 A typical sucker rod joint (API)

TABLE 2 Sucker rod data

Rod size, in (mm)	Pin size, in (mm)	Coupling OD, in (mm)	Cross- sectional area, in <sup>2</sup> (mm <sup>2</sup> )	Dry weight, lb/ft (kg/m)	Stretch factor <i>C</i> , USCS <sup>a</sup> (SI) <sup>b</sup>
$\frac{5}{8}$ (15.88)	$\frac{15}{16}$ (23.81)	$1\frac{5}{8}$ (41.28)	0.307 (198)	1.15 (1.71)	1.322 (24.76)
$\frac{3}{4}$ (19.05)	$1\frac{1}{16}$ (26.99)	$1\frac{13}{16}$ (46.04)	0.442 (285)	1.63 (2.43)	0.919 (17.21)
$\frac{7}{8}$ (22.22)	$1\frac{3}{16}$ (30.16)	$2\frac{3}{16}$ (55.66)	0.601 (388)	2.18 (3.25)	0.676 (12.66)
1 (25.40)	$1\frac{3}{8}$ (34.92)	$2\frac{3}{8}$ (60.32)	0.785 (507)	2.94 (4.38)	0.517 (9.68)

<sup>a</sup>in/1000 ft · 1000 lb load

<sup>b</sup>mm/km · kN load

sucker rod string. Maximum design stress for sucker rods is between 30,000 and 40,000 lb/in<sup>2</sup> (207 and 276 MPa), depending on the metallurgy of the rod and the corrosive environment of the well. Useful data for designing sucker rod strings are shown in Table 2.

**TABLE 3** Maximum rating of standard pumping units

Torque, in · lb (N · m)	Stroke length, in (m)	Structure capacity, lb (kN)	Design spm <sup>a</sup>
6,400 (8,677)	16 (0.406)	3,200 (14.23)	25
10,000 (13,560)	20 (0.508)	4,000 (17.79)	25
16,000 (21,690)	24 (0.610)	5,300 (23.58)	25
25,000 (33,800)	30 (0.762)	6,700 (29.80)	24
40,000 (54,230)	36 (0.914)	8,900 (39.59)	22
57,000 (77,280)	42 (1.07)	10,900 (48.49)	20
80,000 (108,400)	48 (1.22)	13,300 (59.16)	19
114,000 (154,600)	54 (1.37)	16,900 (75.17)	18
160,000 (216,900)	64 (1.63)	20,000 (88.96)	17
228,000 (309,000)	74 (1.88)	24,600 (109.4)	15
320,000 (433,900)	120 (3.05)	25,600 (113.9)	12
456,000 (618,300)	144 (3.66)	30,400 (135.2)	11
640,000 (867,700)	168 (4.27)	35,600 (158.4)	10
912,000 (1,237,000)	192 (4.88)	42,700 (189.9)	9

<sup>a</sup>Design spm (strokes per minute) is based on a Mills impulse load of 0.25 with a maximum spm of 25. This cycle rate may be exceeded; however, the values given here are considered good design practice.

Design of a single-size string for use in wells of shallow to moderate depth is a straightforward calculation and the tables and formulas included here are sufficient. In deeper wells, tapered\* strings of rods are used, frequently  $1\frac{7}{8}$ , and  $\frac{3}{4}$  in (25.4, 22.2, and 19.0 mm). Various methods are used for calculating the proper taper, but so many variables are involved that computer programs are frequently used to provide the total system design.

**Surface Pumping Units** Rating standards of beam pumping units have been established by the American Petroleum Institute (API). There are fourteen gear reducer torque ratings established, and these can be combined with various structures and a variety of stroke lengths to supply a pumping unit matched to virtually any well condition. Table 3 shows these torque ratings, the maximum stroke length, and the maximum structure capacity of standard units.

**Pumping Installation Calculations** The pump bore (ID of the pump barrel) is selected based on the quantity of fluid to be produced. A trial calculation is made to select a pump bore and a pumping unit stroke length that will produce the required volume of fluid. A volume calculation at 100% efficiency is performed using the bore factor from Table 4 and the stroke length and design strokes-per-minute value shown in Table 3. This is multiplied by 0.7 to correct for anticipated pump efficiency under average well conditions.

**WEIGHT OF FLUID ON PLUNGER** The trial calculation continues with the weight of the fluid on the plunger. Freshwater exerts a pressure of 0.433 lb/in<sup>2</sup> per vertical foot (9.79 kPa per vertical meter). The weight of the fluid on the plunger can be calculated with the formula

$$\text{in USCS units} \quad W_f = 0.433 A_p D(\text{sp. gr.})$$

$$\text{in SI units} \quad W_f = 0.00979 A_p D(\text{sp. gr.})$$

\*When the sucker rod string is made up of several shorter strings, each of a different diameter, the total string is called tapered because the smallest-diameter strings are at the bottom and the largest at the top. This is done to reduce the total weight and to maintain approximately the same stress levels top to bottom.

**TABLE 4** Sucker rod pump data

Pump bore, in (mm)	Plunger area, in <sup>2</sup> (mm <sup>2</sup> )	Bore factor, USCS <sup>a</sup> (SI) <sup>b</sup>
1 $\frac{1}{16}$ (26.99)	0.887 (572.1)	0.132 (0.826)
1 $\frac{1}{4}$ (31.75)	1.227 (791.7)	0.182 (1.139)
1 $\frac{3}{8}$ (38.10)	1.767 (1140.)	0.262 (1.639)
1 $\frac{3}{4}$ (44.45)	2.405 (1552.)	0.357 (2.234)
2 (50.80)	3.142 (2027.)	0.466 (2.917)
2 $\frac{1}{4}$ (57.15)	3.976 (2565.)	0.590 (3.691)
2 $\frac{1}{2}$ (63.50)	4.909 (3167.)	0.728 (4.555)
2 $\frac{3}{4}$ (69.85)	5.940 (3832.)	0.881 (5.512)
3 $\frac{1}{4}$ (82.55)	8.296 (5352.)	1.231 (7.702)
3 $\frac{3}{4}$ (95.75)	11.045 (7126.)	1.639 (10.255)

<sup>a</sup>Bore factor  $\times$  stroke length in inches  $\times$  spm = barrels/day (42-gal oil barrels).

<sup>b</sup>Bore factor  $\times$  stroke length in meters  $\times$  spm = cubic meters/day.

where  $W_f$  = weight (force) of fluid on plunger, lb (N)

$A_p$  = area of plunger (Table 4), in<sup>2</sup> (mm<sup>2</sup>)

$D$  = fluid lift, distance from fluid level while pump is operating to ground surface, ft (m)

sp. gr. = specific gravity of fluid pumped, ratio of density of fluid to density of water at 60°F (16°C)

**WET WEIGHT OF RODS** The next calculation is the weight of the rods. The dry weight (force) of the rods  $W_r$  in pounds is computed by multiplying the weight (force) per foot of the rods (Table 2) by the length of the rods. This weight (force) in newtons is kilograms per meter times the acceleration of gravity (9.807 m/s<sup>2</sup>) times the length of the rod. Because the rods have buoyancy when immersed in a fluid, their wet weight (force)  $W_w$  can be calculated with the formula

$$W_w = W_r (1 - 0.128 \text{ sp. gr.})$$

**DEAD WEIGHT OF RODS AND FLUID** This value is needed in subsequent calculations. It is the weight (force) of fluid on the plunger plus the wet weight of the rods:

$$W_{df} = W_f + W_w$$

**IMPULSE LOAD** The acceleration due to the reciprocating motion of the rods causes additional stresses in the sucker rod string. Twice during each stroke,<sup>c</sup> the rods are stopped and their motion reversed as they follow a sinusoidal acceleration pattern provided by the pumping unit. The resulting impulse load can be approximated using the Mills impulse load formula:

$$\text{in USCS units} \quad I = \frac{L (\text{spm})^2 W_r}{70,000}$$

$$\text{in SI units} \quad I = \frac{L (\text{spm})^2 W_r}{1780}$$

<sup>c</sup>In oil field terminology, a stroke is defined as the complete up and down cycle of the plunger. Distance traveled in one direction is stroke length.

where  $I$  = impulse load, lb (N)  
 $L$  = length of polished rod stroke, in (m)  
 spm = strokes per minute  
 $W_r$  = dry weight (force) of rods, lb (N)

**PEAK POLISHED ROD LOAD** The peak polished rod load  $P$  is

$$P = W_{df} + I$$

This peak polished rod load is used in final sizing of the surface pumping unit. If a single size of rod is used,  $P$  divided by the cross-sectional area of the rod gives the maximum rod stress. In a tapered string of rods,  $P$  divided by the cross-sectional area of the top rod will also approximate the maximum rod stress unless the rod string design is such that the rod under maximum stress is not at the top but lower in the string.

**MINIMUM POLISHED ROD LOAD** In addition to the peak polished rod load, a minimum polished rod load is also needed to determine the peak torque on the gearbox of the surface pumping unit. The minimum polished rod load  $P_m$  is

$$P_m = W_{df} - I$$

**LOAD RANGE** Load range  $P_r$  is

$$P_r = P - P_m$$

**PEAK TORQUE** The work transmitted from the prime mover through the gear reducer and crank applies a torque to the gears. Gear reducers are rated by the peak torque they can carry on a continuous basis. The peak torque  $T$  in inch-pounds (newton-meters) is proportional to the load range and may be calculated from the formula

$$T = 0.25P_rL$$

The calculated peak torque must be lower than the torque rating, and the calculated peak polished rod load must be lower than the structure capacity rating of the unit selected (Table 3).

**POLISHED ROD POWER** The polished rod power  $P_{pr}$  in horsepower (kilowatts) can be calculated from the formula

$$\text{in USCS} \quad P_{pr} = \frac{L (\text{spm})^2 P_r}{750,000}$$

$$\text{in SI units} \quad P_{pr} = \frac{L (\text{spm})^2 P_r}{113,600}$$

Because the polished rod power calculation does not take friction into account, the prime mover selected should have at least double the power of the calculated figure.

**PLUNGER OVERTRAVEL** In accurately calculating pump displacement, it is necessary to calculate the actual plunger stroke, which is not the same as the polished rod stroke. The plunger gains stroke from overtravel. Long strings of rods are elastic and capable of stretching several feet. When the pumping unit stops the polished rod at the bottom of the surface stroke, the plunger continues to move downward because of inertia. This plunger overtravel  $OT$  in inches (meters) can be calculated from the formula



**TABLE 5** External upset tubing data

Tubing size, in (mm)	Actual ID, in (mm)	Weight T&C, <sup>a</sup> lb/ft (kg/m)	Upset OD, in (mm)	Collar OD, in (mm)	Shrink factor <i>K</i> USCS (SI)
2 $\frac{3}{8}$ (60.32)	1.995 (50.67)	4.63 (6.89)	2.594 (65.89)	3.063 (77.80)	0.313 (5.86)
2 $\frac{7}{8}$ (73.02)	2.441 (62.00)	6.44 (9.58)	3.094 (78.59)	3.668 (93.17)	0.224 (4.20)
3 $\frac{1}{2}$ (88.90)	2.992 (76.00)	9.27 (13.80)	3.750 (95.25)	4.500 (114.30)	0.151 (2.83)

<sup>a</sup>Threaded and coupled

$$\text{in USCS units} \quad OT = \frac{(R_t \times \text{spm})^2 L}{50,000}$$

$$\text{in SI units} \quad OT = \frac{(R_t \times \text{spm})^2 L}{4645}$$

where  $R_t$  is the total length of rod string in 1000 feet (kilometers).

**SUCKER ROD STRETCH, TUBING SHRINK** The sucker rod stretch starts when the plunger starts its upstroke and the fluid load is transferred from the tubing string to the sucker rod string. This occurs when the standing valve opens and the traveling valve closes. As the sucker rod string lengthens, the tubing string shortens. Both result in a stroke loss. The stroke loss due to rod stretch is shown in Table 2 as factor  $C$ , and the stroke loss due to tubing shrink is shown in Table 5 as factor  $K$ . Both are in inches per 1000 feet per 1000 pounds load (millimeters per kilometer per kilonewton).

**NET PLUNGER STROKE** The formula below illustrates a method of computing the net plunger stroke for a tapered string of 1-,  $\frac{7}{8}$ - and  $\frac{3}{4}$ -in (25.4-, 22.2- and 19.0-mm) rods with the tubing suspended freely. If the tubing is anchored to the well casing near the pump, the  $KR_t$  factor will be zero.

$$\text{In USCS units} \quad L_p = L + OT - (CR_1 + CR_2 + CR_3 + KR_t)W_f \times 10^{-3}$$

$$\text{In SI units} \quad L_p = L + OT - (CR_1 + CR_2 + CR_3 + KR_t)W_f \times 10^{-6}$$

where  $L_p$  = net plunger stroke, in (m)

$R_1$  = length of  $\frac{3}{4}$ -in (19.0-mm) rods, 1000 ft (km)

$R_2$  = length of  $\frac{7}{8}$ -in (22.2-mm) rods, 1000 ft (km)

$R_3$  = length of 1-in (25.4-mm) rods, 1000 ft (km)

$R_t$  = length of tubing string, 1000 ft (km)

For a single-size rod string, zero values are assigned to the sizes not used. The pump displacement can now be calculated with the formula

$$\text{in USCS units,} \quad \text{Barrels/day} = L_p \times \text{bore factor} \times \text{spm} \times 0.8$$

$$\text{in SI units} \quad \text{Cubic meters/day} = L_p \times \text{bore factor} \times \text{spm} \times 0.8$$

The 0.8 factor assumes an 80% pump volumetric efficiency after correcting for sucker rod stretch and plunger overtravel. A lower efficiency should be assumed if the well is known to be gassy. If the pump displacement is more than required and the torque and

structure capacity ratings of the unit are not exceeded, the calculations should be repeated using the next smaller size unit.

**COUNTERBALANCE** The pumping unit is supplied with a counterbalance in order to load the prime mover equally on the upstroke and the downstroke. The counterweights balance out the wet weight of the rods and half the weight of the fluid. All of the work in lifting is done on the upstroke. The energy stored in the counterweights during the downstroke supplies about half of the energy required for lifting the fluid. Because it lifted no fluid on the downstroke, the prime mover expends its energy lifting the unbalanced portion of the counterbalance load. Counterbalance effect  $CB$  is

$$CB = W_w + 1/2 W_f$$

The pumping unit pictured in Figure 1 is known as a beam pumping unit. These are most common, but there are other types. One is a hydraulic surface unit, where a cylinder is set directly over the wellhead and a piston provides the reciprocating motion of the rods. These use commercial hydraulic pumps and control valves to supply the hydraulic power to the piston.

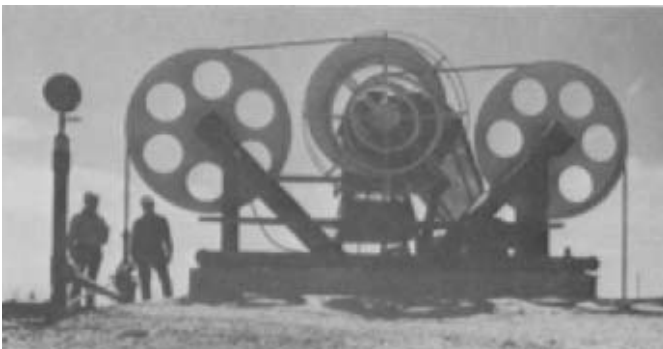
As shown in Table 3, standard sizes of beam pumping units have stroke lengths ranging from a little more than 1 ft (0.3 m) to a maximum of 16 ft (4.9 m). Recently a number of units have been marketed that permit stroke lengths up to 40 ft (12 m). The long stroke improves pump efficiency, prolongs sucker rod life, and reduces energy requirement. The unit pictured in Figure 5 uses wire line wound and unwound on a reversible drum to supply the reciprocating motion.

### **SUBSURFACE HYDRAULIC PUMPING SYSTEM**

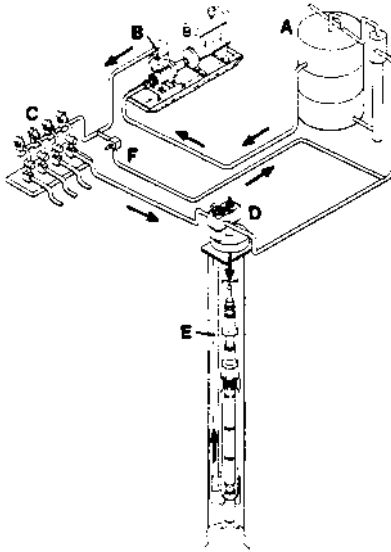
A complete hydraulic system consists of a fluid cleaning system, a power pump (usually a triplex), surface controls, a subsurface hydraulic pump, and tubing connecting the surface power pump to the subsurface pump. (See Section 3.1 for a complete description of power pumps.) Figure 6 is a schematic drawing of a complete multiple-well hydraulic system.

Because the pressurized power fluid supplies the energy needed to pump the well, the heavy sucker rod string and the heavy structure of the pumping unit required with the sucker rod pump are eliminated. Therefore, the hydraulic system can produce larger volumes of fluid from greater depths than the sucker rod pump.

The subsurface pump can be either a reciprocating piston pump or a jet pump. Both are usually made to be interchangeable in the same subsurface installation. Both pumps are



**FIGURE 5** Winch pumping unit (Bethlehem Steel)



**FIGURE 6** Multiple-well hydraulic installation: (A) power fluid tank, (B) triplex pump, (C) manifold, (D) well-head, (E) tubing, (F) bypass valve (Kobe)

made in what is called the free pump configuration, which means that the pump assembly can be pumped down into the well or pumped out of it by the same surface power fluid system that powers the pump during normal operation with the pump on the bottom. The free pump feature gives the hydraulic pump a distinct servicing advantage over the sucker rod pump, which requires a mast or derrick over the well and a pulling unit to pull the rods one or two at a time when the pump needs servicing.

There are two basic types of hydraulic installations for the free pump: parallel free and casing free. Both result in a U-tube arrangement in which one leg of the U tube delivers the power fluid to the pump at the bottom and the other leg directs spent power fluid plus production back up to the surface. In the parallel free system, two parallel tubing strings\* make up the U tube, and both are lowered into the well casing. In the casing free system, only one string is lowered into the well, and the annulus between this tubing and the well casing acts as the second leg of the U tube. Figure 7a illustrates installing a hydraulic pump in a parallel-free installation. A standing valve closes the bottom of the U tube, and the two strings are filled with fluid. The pump is inserted into the power fluid string, which is then securely capped, and the four-way valve is set to pump power fluid down the power fluid tubing. When the hydraulic pump reaches the bottom, a tapered bottom plug engages a seat on the standing valve and forms a pressure-tight seal. At the same time, an elastomer seal at the top of the pump enters a seal that now forces power fluid into the hydraulic pump (Figure 7b) to start it pumping (as described later). When it is desired to retrieve the pump to replace worn parts, the position of the four-way valve is reversed and power fluid is directed down the production tubing (Figure 7c.) The standing valve closes, the pump is unseated, and the circulation of fluid carries the pump to the surface, where it latches into the cap. The pressure is bled off from the U tube, and the wellhead cap with the worn pump is removed from the well.

\*Individual joints of tubing coupled together to reach from the wellhead to the subsurface pump are called tubing strings.

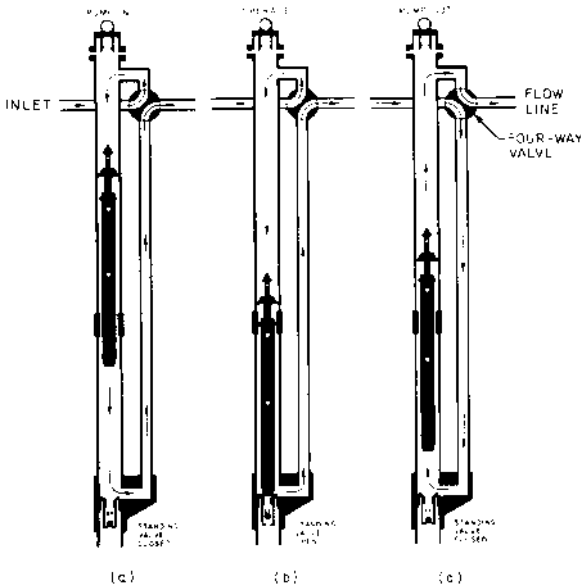


FIGURE 7A through C Hydraulic parallel free pump installation

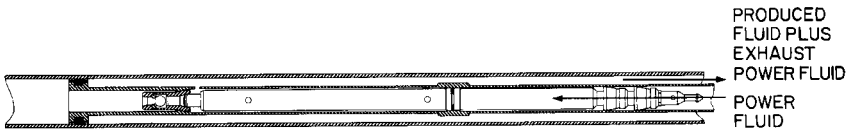


FIGURE 8 Casing free installation

The casing free installation (Figure 8) employs a packer that anchors and seals the tubing to the casing just below the pump assembly. The annulus between the tubing and casing above the packer takes the place of the production string in the parallel free installation. In operation, the power fluid is pumped down the power fluid string as before, but the mixture of exhaust power fluid plus production is returned to the surface in the tubing casing annulus. The annulus below the standing valve is at pump suction pressure. The casing free hydraulic pump installation is more economical because it requires only one string of tubing. It also has the advantage that the return fluid passage up the annulus is very large and fluid frictional losses are very low.

Natural gas separates from the crude oil as it enters the well bore. In the parallel free installation, this gas rises to the surface in the annulus between the tubing strings and the casing, entering the flow line with the produced fluid at the wellhead. In the casing free installation, however, this annulus is used to return the liquid discharged from the pump, and all of the produced gas must be pumped with the produced liquid. The hydraulic pump is not very efficient in pumping gas. Therefore, in gassy wells, the pump efficiencies for the casing free system will be lower.

Both the reciprocating hydraulic pump and the jet pump are designed to operate on fluid from the well. Either crude oil or water may be used as the power fluid. Sand particles and other abrasives contained in the produced fluid are removed either by gravity separation in surface settling tanks or by centrifugal force in cyclone separators. The cleaned

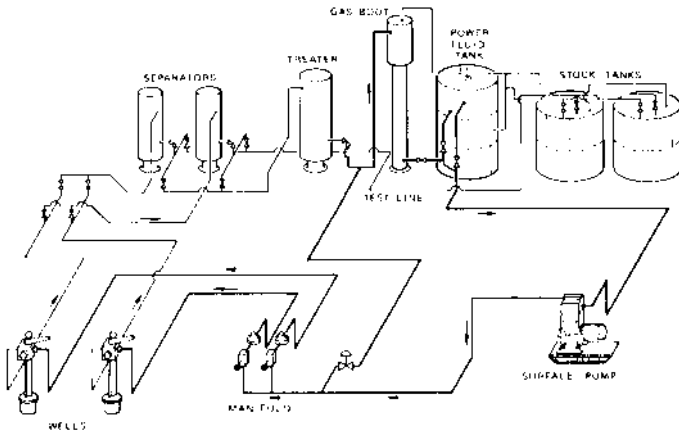


FIGURE 9 Typical central system (Kobe)

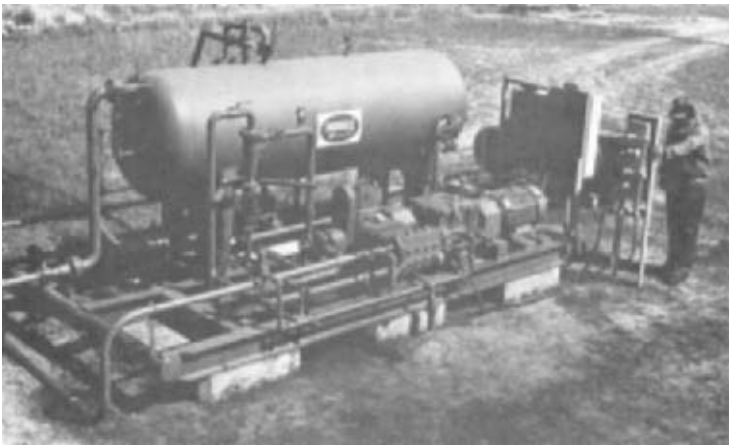


FIGURE 10 One-well unitized system (National Supply)

oil or water is then pressurized—typically to between 2500 and 4000 lb/in<sup>2</sup> (172 and 276 bar)—by a power pump at the surface, and then the high-pressure fluid is returned down the power fluid tubing to operate the subsurface hydraulic pump. The exhausted power fluid from the hydraulic pump mixes with the produced fluid from the well, and the mixture is returned to the surface in the parallel side string or the casing tubing annulus.

Figure 9 illustrates a typical central system. The power fluid is separated by settling in tanks. A triplex pump or a battery of triplex pumps manifolded together supplies the power fluid to a number of oil wells. Figure 10 shows a one-well unitized system, in which the combined stream of well production and power fluid is brought into a pressure vessel for a brief period for gas separation and solids settling. The selected fluid is then passed through a cyclone for cleaning before going to the surface pump. The abrasive-laden underflow from the cyclone and the surplus fluid from the pressure vessel then go into the flow line and are carried to the lease tanks. This fluid constitutes the well production.

**Subsurface Reciprocating Hydraulic Pumps** A subsurface reciprocating hydraulic pump basically consists of an engine piston and cylinder with an engine reversing valve, and a pump barrel and plunger. These are assembled into one unit, and a polished rod connects the engine piston to the pump plunger so the two reciprocate together.

Several designs of subsurface hydraulic reciprocating pumps are available. Figure 11a is a schematic of a double-acting pump. The engine valve directs high-pressure power fluid below the piston and opens the area above the piston to exhaust pressure on the upstroke. On the downstroke, it directs high-pressure power fluid above the piston and exhausts the power fluid below the piston to low pressure. The double-acting design exhausts an equal amount of power fluid from the engine and produces fluid from the pump on the upstroke and downstroke.

Figure 11b illustrates a balanced-design pump where the polished rod area is equal to half of the piston area. The underside of the piston is always connected to high-pressure power fluid. On the downstroke, the engine valve directs high pressure on top of the piston. Because this area is larger than the bottom area of the piston, the unit makes a downstroke. On the upstroke, the engine valve exhausts the area above the piston to low pressure. The high pressure below the piston then causes the unit to make an upstroke. The balanced design exhausts all of the spent power fluid on the upstroke and all of the produced fluid displaced by the pump on the downstroke.

Figure 11c illustrates a single-acting pump where the polished rod area is small relative to the piston area. The underside of the piston is always connected to high-pressure power fluid. The engine valve directs high-pressure power fluid to the top of the piston on the downstroke and exhausts it to low pressure on the upstroke. The single-acting unit exhausts all of the exhaust power fluid and most of the produced fluid displaced by the pump on the upstroke. Only the displacement of the polished rod is exhausted on the downstroke.

In general, subsurface hydraulic reciprocating pumps are used in small- to medium-volume wells. When they are installed in 2 $\frac{3}{8}$ -in (60-mm) OD tubing, they are most commonly used to produce 25 to 500 barrels/day (4 to 80 m<sup>3</sup>/day); in 2 $\frac{7}{8}$ -in (73-mm) OD tubing, from 50 to 1000 barrels/day (8 to 158 m<sup>3</sup>/day); and in 3 $\frac{1}{2}$ -in (89-mm) OD tubing, from 100 to 1500 barrels/day (16 to 240 m<sup>3</sup>/day). Where conditions are right, these volumes can be exceeded, but in the higher volume ranges, the jet pump is usually a better application. Most subsurface hydraulic units have a maximum power fluid pressure rating of 4000 lb/in<sup>2</sup> (278 bar).

Reciprocating hydraulic pumps are available in several pressure ratios. For moderate-depth wells, the engine cylinder and the pump barrel can be of the same diameter. In deeper wells, a pump plunger smaller than the engine cylinder is used; thus the operating pressure can be reduced proportionally, but a proportionally greater quantity of power fluid will be required. Hydraulic pumps are also offered with tandem engines and single pump for deep wells and with single engine and tandem pumps for shallow wells. The pump-to-engine-area ratio in these models varies from a low of 0.40 to a high of 2.00. There is no standardization of design among the various manufacturers, and the models of each are so diverse that no typical charts are offered here. Data can be obtained from the individual manufacturers.

As mentioned previously, the complete up and down cycle of the piston and plunger is called a stroke, and the distance traveled in one direction is called the stroke length. Stroke lengths offered vary from 1 to 5 ft (0.3 to 1.5 m). Stroke-per-minute ratings are from 200 on the shortest stroke to 50 on the longest stroke. The strokes are visible on the surface pressure gage because the pressure rises at each reversal when fluid flow is momentarily interrupted. Because the triplex power pump is positive displacement, the power fluid rate to the pump is usually controlled by bypassing the unneeded surplus. Some triplex pumps are equipped with a three-speed manual transmission that can be used to vary the speed of the surface pump. By selecting the proper rotational speed, the output volume of the surface pump can be adjusted closely to the requirements of the subsurface pump. The triplex pump normally runs continuously, although occasionally in small-volume wells, it will be run intermittently by a time clock.

**Subsurface Jet Pumps** A jet pump has no moving parts, but it pumps by transferring momentum from a very-high-velocity—1000 ft/s (300m/s)—fluid jet to the pumped fluid

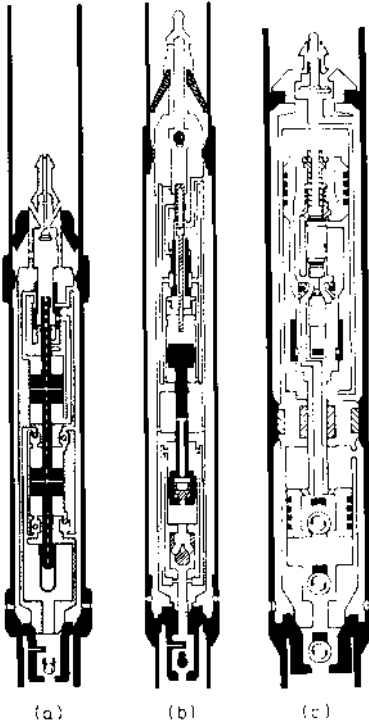


FIGURE 11 Designs of subsurface hydraulic pumps: (a) double-acting, (b) balanced, (c) single-acting

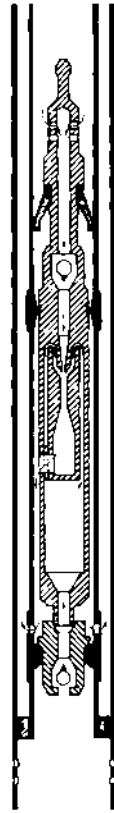
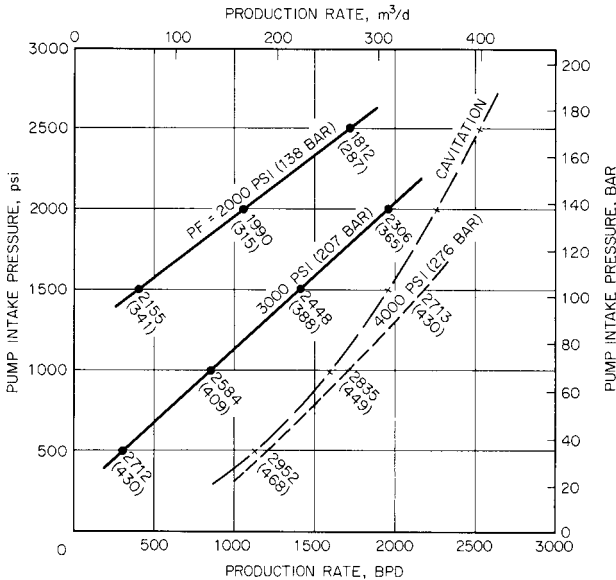


FIGURE 12 Jet free pump

(Figure 12). At the nozzle exit, the jet creates a low-pressure area, thereby drawing in the fluid and carrying it to the throat of the pump, where the momentum transfer is completed. Then the combined stream enters the expanding tapered section of the diffuser, where the velocity head is converted back to a static head. The static head at this point is sufficient to lift the combined stream back to the surface. For a complete description of the general theory of jet pumps, see Chapter 4.

The jet pump has a broad range of application. It has been applied in wells as shallow as 800 ft (240 m) and as deep as 15,000 ft (4800 m). In general, a jet pump is capable of producing wells in the following volume ranges: in  $2\frac{3}{8}$ -in (60-mm) OD tubing, from 25 to 8000 barrels/day (4 to 475 m<sup>3</sup>/day); in  $2\frac{5}{8}$ -in (73-mm) OD tubing, from 50 to 6000 barrels/day (8 to 950 m<sup>3</sup>/day); and in  $3\frac{1}{2}$ -in (89-mm) OD tubing, from 100 to 12,000 barrels/day (16 to 1900 m<sup>3</sup>/day).

Jet pumps are less energy-efficient than reciprocating pumps. A well-designed jet pump may perform at approximately 40% hydraulic efficiency, as compared with more than 90% efficiency for a reciprocating pump. However, jet pumps do have numerous advantages. With no moving parts, they have a high level of reliability, and sustained runs of several years are not uncommon. In addition to their high volume capability, jet pumps have a higher tolerance to abrasives in the produced fluid as well as in the power fluid. They are also more efficient in handling entrained gas in the pumped fluid.



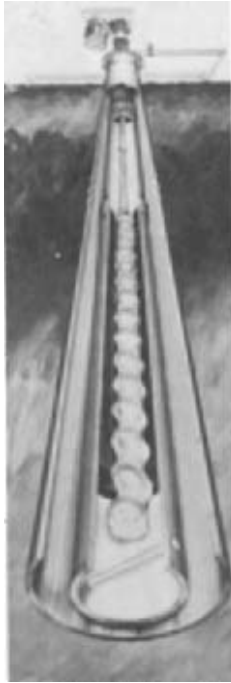
**FIGURE 13** Typical characteristic curves for a jet pump. Numbers adjacent to curves are power fluid in barrels (cubic meters) per day. Jet pump operation must be above and to the left of cavitation line.

Manufacturers offer a broad range of nozzle and throat sizes to cover the varied requirements of depths and volumes. Published data show the smallest nozzle requires 13.5 hydraulic hp (10 kW) and the largest requires 506 hydraulic hp (377 kW) at 4000 lb/in<sup>2</sup> (276 bar) power pump pressure. It requires a complex calculation to determine the optimum nozzle and throat sizes for any given set of well conditions. Manufacturers offer computer solutions, usually in graphical form. Variable factors such as tubing friction, changing specific gravity due to gas, and changing well conditions all contribute to the need of a graphical presentation. The chart in Figure 13 shows a jet pump calculation for an 8000-ft (2440-m) well to predict the anticipated production volume versus pump intake pressure for power fluid pressures of 2000, 3000, and 4000 lb/in<sup>2</sup> (138, 207, and 276 bar). Note that at 4000 lb/in<sup>2</sup> (276 bar) power oil pressure, the pump would be cavitating, and this condition must be avoided. Cavitation occurs when the pressure at the entrance of the throat is less than the vapor pressure of the fluid pumped. The collapse of cavitation bubbles in the throat is so damaging that no known metal can resist destruction. Throat life in severe cavitation can be as short as two or three days. It may also be noted from the chart that the jet is very sensitive to pump intake pressure. Both the production rate and the overall hydraulic efficiency increase as pump intake (suction) pressure increases. A down-well pressure-recording instrument may be installed with the jet pump. It records pump intake pressure versus time for a six-day period, at the end of which the jet pump with the instrument is pumped out and the pressure recording read and analyzed. This information is then used to determine if the nozzle and throat sizes are optimum and to select the power fluid pressure that will maximize production but still avoid cavitation.

**Subsurface Progressing Cavity Pumps** A positive displacement screw-type pump (Section 3.7) can be used for handling the range of oil field fluids. Rotative speed can be varied to match well production with a smooth and steady delivery. No valves are required for pump operation. This type of pump is well suited to handling gaseous formations.

As shown in Figure 14, the rotor is a single rounded-cross-section external screw. The stator is a double internal helix molded of synthetic rubber. As the rotor turns, cavities





**FIGURE 14** Subsurface progressing cavity pump (Fluids Handling Division, Robbins & Myers)

form, and these cavities remain the same size as they progress from the bottom suction to the top discharge. The pump stator is suspended from a standard API tubing string and driven by standard API sucker rod. The pump is electric-motor-driven through belts and sheaves to obtain desired speeds.

Pumps of this type are available for oil well services (or for pumping fluids out of gas wells) to 3000 ft (914) or more. For pumping light or heavy crudes, pump sizes are available up to 100 barrels/day (16 m<sup>3</sup>/day) with speeds varying up to 550 rpm and power ratings to 5 hp (3.7 kW), depending on the well depth and flow required. A sucker rod size of  $\frac{5}{8}$  in (15.9 mm) is common.

### **ELECTRIC SUBMERSIBLE CENTRIFUGAL PUMPS**

Electric submersible centrifugal pumps are adapted to a wide variety of pumping conditions. However, because of their high capacity, they are most frequently installed in wells where the volume of fluid to be produced exceeds the capacity of sucker rod or reciprocating hydraulic pumps. They are installed suspended from the discharge tubing and submerged in the well fluid. A three-conductor electric cable strapped to the discharge tubing transmits the power to the motor to the end of the pump.

The electric submersible pump system is illustrated schematically in Figure 15. The electric motor and pump rotate at 3500 rpm to 60-Hz power and 2900 rpm for 50-Hz power. The electric motor is directly coupled to the pump with a seal section between the two. The motor is filled with an oil especially selected to provide high dielectric strength, lubrication for the bearings, and good thermal conductivity. The seal section isolates this

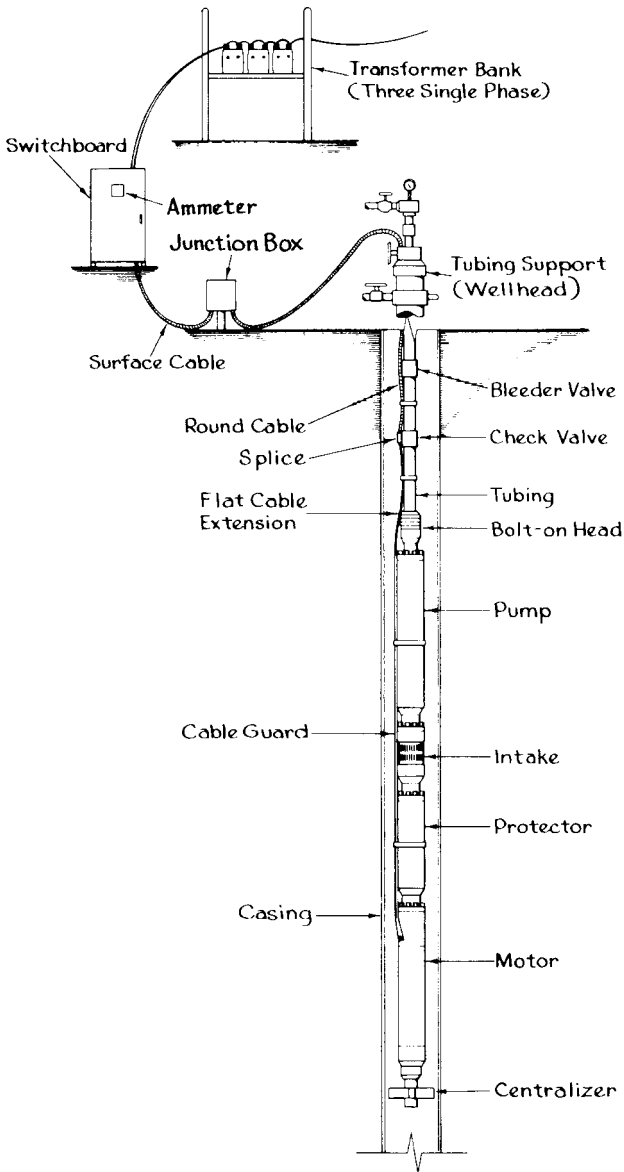


FIGURE 15 Electric submersible centrifugal pump system (PennWell Publishing)

fluid from the pump and allows for expansion and contraction of the fluid with temperature changes at the bottom of the well. The motor, which is the bottom element of the assembly, is usually installed in the well above the casing perforations where the fluid enters the well bore. This allows all of the fluid entering the pump suction to flow past the motor housing and provide the needed cooling.

**TABLE 6** Typical characteristics electric submersible centrifugal pumps

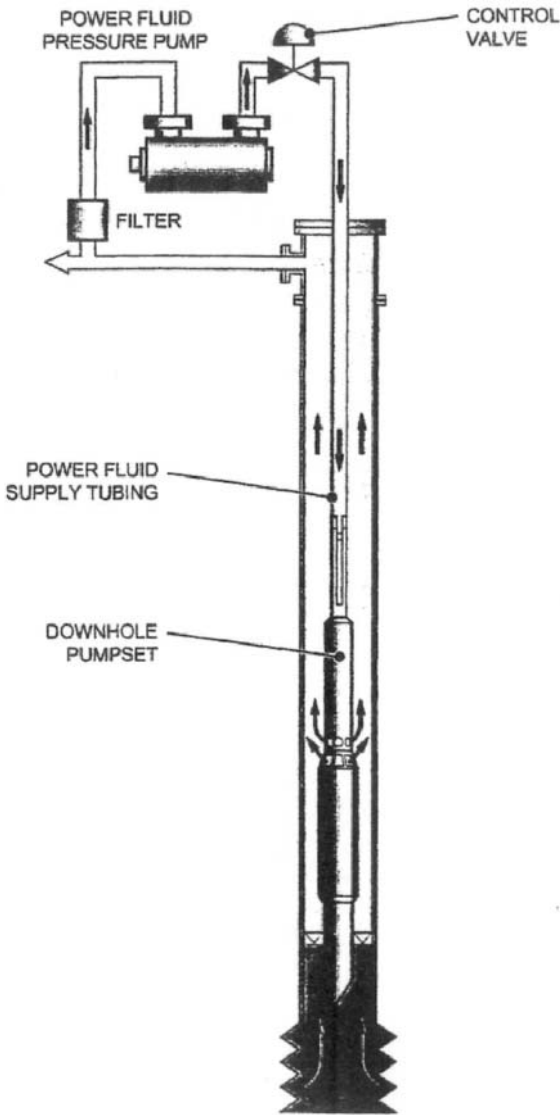
Well casing OD, in (mm)	Motor OD, in (mm)	Pump OD, in (mm)	Motor power, hp (kW)		Pump capacity, bbl/day (m <sup>3</sup> /day)		Pump head per stage, ft (m)	Efficiency, pump only, %
			Min	Max	Min	Max		
4.500 (114)	3.75 (95)	3.75 (95)	25 (18.7)	127 (94.7)	400 (64)	1,500 (238)	16 (5.2)	54
5.500 (140)	4.56 (116)	4.56 (116)	120 (89.5)	240 (179)	400 (64)	2,800 (445)	23 (7.5)	61
7.000 (178)	4.56 (116)	5.40 (137)	120 (89.5)	—	1,400 (223)	7,000 (1113)	30 (9.8)	68
—	5.40 (137)	5.40 (137)	—	600 (488)	1,400 (223)	7,000 (1113)	—	—
8.625 (219)	4.56 (116)	6.50 (165)	120 (89.5)	—	12,000 (1908)	20,000 (3180)	42 (13.8)	72
—	5.40 (137)	6.50 (165)	—	600 (488)	12,000 (1908)	20,000 (3180)	—	—
—	7.38 (188)	6.50 (165)	—	720 (537)	12,000 (1908)	20,000 (3180)	—	—

The small diameter of the casing in which these pumps must be run severely limits design options. Length must be substituted for diameter to achieve the needed characteristics, and the motor design of the electric submersible pump barely resembles its surface counterpart. Single-motor assemblies range up to 32 ft (9.8 m) in length, and when power requirements exceed that of a single motor, two or more motors are assembled in tandem. The pumps must use many stages in order to gain the required head. The smallest-diameter pump—3.75-in (95.2-mm) OD—has 166 stages in an overall length of 12 ft (3.7 m). In deeper wells, two or more of these units can be assembled in tandem to gain the needed head. Manufacturers catalog pump combinations with as many as 400 stages. Table 6 gives typical data on the more common sizes. The numbers in the table are not limits, and manufacturers have available both smaller and larger sizes than those shown.

### HYDRAULIC SUBMERSIBLE CENTRIFUGAL PUMPS

Hydraulic turbine drive submersible pumps have been an emerging technology since the 1980s. They are particularly suited for use in wells where other artificial lift technologies are unsuitable due to high liquid viscosity, high temperature, or high gas-to-oil ratio. The hydraulic turbine drive submersible pumpset unit comprises a multistage turbine mounted on a common shaft with a multistage centrifugal pump located directly below it. They are installed in the well bore as part of the production tubing, by wireline or coiled tubing methods, and are submerged in the well fluid.

The simplest hydraulic submersible pump system consists of a surface charge pump, power fluid control valve, hydraulic submersible pumpset, and a power fluid filter (Figure 16). In operation, power fluid is boosted in pressure by the surface charge pump and is passed through the control valve before being injected down the well tubing and into the turbine. The power fluid drives the turbine stages, causing the pump to rotate before exhausting at the lower end of the turbine unit. The pump suction flow enters at the bottom of the pump and is boosted in pressure through the various pump stages before discharging at the upper end of the pump unit. The most common configuration (open loop) results in the discharged pump flow comingling with the exhaust power fluid and returning to the surface for separation and processing. The power fluid is then filtered and



**FIGURE 16** Aquifer lift principle of operation (Weir Pumps Ltd.)

returned to the surface charge pump to begin the cycle over again. The turbine power fluid can be produced water, aquifer water, or produced oil, depending on which is more suitable for the application under consideration. The ratio of power to produced fluid is in the region of 1:1, although this can be varied to suit specific operational flow and pressure requirements.

Oil field artificial lift systems require a high degree of flexibility to take account of changing well conditions that may alter over the installed life of the pumpset. The hydraulic submersible pump is a nominally constant power machine that will use all the

**TABLE 7** Typical characteristics of a hydraulic submersible centrifugal pump

Well casing OD, in (mm)	Turbine OD, in (mm)	Pump OD, in (mm)	Capacity bbl/day (m <sup>3</sup> /day)	Max. Pump Head per stage, ft (m)	Pump Efficiency, pump only, %
5.500 (140)	3.465 (88)	4.528 (115)	8000 (1260)	143 (44)	62
7.000 (178)	5.433 (138)	5.709 (145)	11,000 (1740)	165 (50)	68.5
7.765 (197)	5.433 (138)	5.906 (150)	19,000 (3000)	165 (50)	70
9.625 (244)	6.772 (172)	7.480 (190)	25,000 (3950)	158 (48)	76
10.750 (273)	8.858 (225)	8.662 (220)	39,000 (6160)	158 (48)	78
11.750 (298)	8.858 (225)	10.630 (270)	75,000 (11,900)	193 (59)	79.5

power being fed to it in the form of flow and pressure energy. By this fact, the pump will automatically vary its speed to take into account varying well conditions. Typical pump speeds are in the region of 8500 rpm for smaller unit to 4000 rpm for larger units. Designs are available from 3000 barrels/day to 75,000 barrels/day (480 m<sup>3</sup>/day to 12,000 m<sup>3</sup>/day), depending on the pumpset configuration. Typical characteristics of hydraulic submersible centrifugal pumps are listed in Table 7.

The hydraulic submersible pump uses clean turbine power fluid to continually flush the pump end bearings while in operation. Hydrostatic bearings are used and the absence of any rolling element bearings or mechanical seals provides a simple, robust construction. The high power density of the hydraulic turbine and the relatively high speed of the pump makes for a compact unit typically less than 20 ft (6 m) long.

## OFFSHORE OIL WELL PUMPS

Most offshore oil well platforms are located in high-pressure fields where the wells will flow from natural pressure for several years. When the pressure declines, the wells are frequently produced with gas lift, where high-pressure gas is directed down the casing. This gas mixes with the well fluid at the bottom of the tubing, and the fluid-gas mixture lightens the fluid gradient in the tubing string to a point where the bottom hole pressure is sufficient to cause the well to flow. Where gas lift is not applicable, wells are pumped with subsurface submersible electric pumps, subsurface hydraulic reciprocating or jet pumps, or sucker rod pumping systems. A few wells are completed with the well head on the ocean floor. These must either flow or be gas-lifted, and the other systems are not applicable.

## FURTHER READING

Brennan, J. R. *Engineering Data and Production Calculations*. National Supply, Los Nietos, CA, 1968.

Brown, K. *The Technology of Artificial Lift Methods, Vol. 2b*. PennWell Publishing, Tulsa, OK, 1980.

*Primer of Oil and Gas Production*. 3rd ed., Johnson Printing, Dallas, TX, 1976.

Shanahan, S. T. *The Basics of Subsurface Oil Well Pumps*, BMW-Monarch, Gardena, CA, 1975.

Wilson, P. M. *Introduction to Hydraulic Pumping*, Kobe, Huntington Park, CA, 1976.

---

# SECTION 9.18

---

# CRYOGENIC LIQUEFIED GAS SERVICE

---

L. R. SMITH  
THOMAS MOYES

The regime of cryogenic technology has been generally taken to indicate temperatures colder than  $-100^{\circ}\text{F}$  ( $-73^{\circ}\text{C}$ ). Fluids such as liquid oxygen, nitrogen, hydrogen, helium, argon, methane, and ethane, with normal boiling points below  $-100^{\circ}\text{F}$  ( $-73^{\circ}\text{C}$ ) are called cryogenic fluids.

For the pump designer, the cryogenic regime requires consideration of the effect of low temperatures on the properties of construction materials and the effect of varying shrinkage rates on critical fits and clearances. The problem is further complicated by the fact that cryogenic fluids are stored at near atmospheric pressure and must be pumped at or near their normal boiling point, so the only *NPSH* available is that due to the liquid level above the pump suction.

The history of commercial cryogenic pumping divides into two eras. The first, commencing in the early 1930s with the first liquid oxygen plant in the United States, was the period in which end-suction shaft seal pumps were developed and produced for pumping liquefied atmospheric gases, such as liquid oxygen, nitrogen, and argon. This industry grew until the late 1960s. Though continuing to grow, the explosive period appears to have ended.

The second era commenced in 1959 with the first transport of a commercial cargo of liquefied natural gas (LNG) from Lake Charles, La., across the Atlantic Ocean to England. This voyage, carrying an almost token quantity of  $5000\text{ m}^3$  of LNG, inaugurated an era of international trade in liquefied hydrocarbon gases that has grown with astounding rapidity and seems still to be barely on the threshold of realizing its full potential.

## **ATMOSPHERIC GASES**

---

Cryogenic pumps first came into being with the production of liquefied atmospheric gases in commercial quantities. The initial liquefaction of air and the subsequent separation of

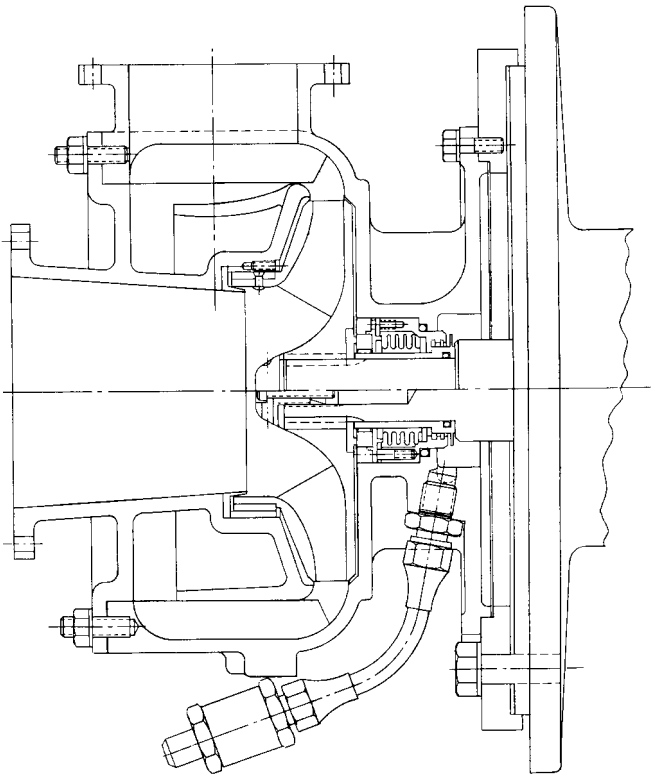


FIGURE 1A In-flight refueling pump (J. C. Carter Company, Inc.)

oxygen and nitrogen did not require pumps because the small volume of liquids produced could be readily transferred by pressure. Early pumps, where needed, were designed and built by the gas companies themselves and were primarily used to fill high-pressure bottles or cylinders. Flows were very low, so positive displacement pumps were commonly used. These were notoriously inefficient, primarily because of the flashing that occurred during the intake stroke and led to a very low volumetric efficiency. However, the low volume of product being handled permitted this efficiency to be tolerated.

The World War II development of rocket engines that used liquid oxygen as an oxidizer to burn kerosene fuel and the postwar development of the large rocket booster required the development of centrifugal pumps to feed the propellants to the engine. These turbine-driven rocket engine pumps were adapted to electric motors for use in transferring the propellants from storage into the rocket's tanks because there were no high-capacity cryogenic pumps available from the industry. Although these early rocket pumps were also inefficient, they could be tolerated in the rocket because the fluid was burned immediately and temperature rise across the pump was not a problem.

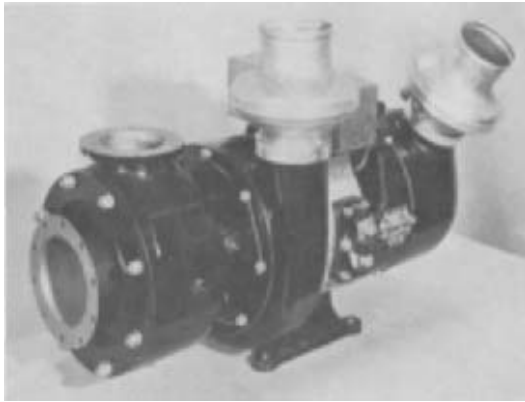
Two other developments in the early postwar years increased the volume of liquefied gases in industrial applications. The first was the development of the basic oxygen furnace for making steel, and the second was the use of liquefied nitrogen in the fast-freezing of foods and as an inert atmosphere for heat-treating and chemical processes. These developments required the storage and transfer of large volumes of liquids, so the boiloff loss due to pump inefficiency became a major economic factor in the profit and loss of the liq-

ufactation company. The major companies instituted internal studies to reduce these losses, and soon the transfer pumps were brought under scrutiny.

Thus a two-pronged impetus developed to find pumps that would more efficiently and reliably transfer these valuable liquids; the first was the need to load military rockets with the coldest possible liquid with utmost reliability, and the second was from industry. Investigators studying the problem first turned to the producers of commercial pumps. However, because the pump volumes required were small and the technical problems formidable, they were unable to retain the interest of the major manufacturers and so turned to small producers of custom-designed pumps.

The earliest custom producer to enter the field was a builder of high-capacity in-flight refueling pumps for the military. One of these pumps was adapted to a commercial 60-Hz electric motor using a newly designed face-type shaft seal with the stationary face mounted on a stainless steel convoluted bellows. A cross section of this pump is shown in Figure 1a.

The refueling pump was constructed of aluminum castings with bronze wear rings and stainless steel trim. These materials were good choices for cryogenic service as well, and so, aside from the seal, it was necessary only to change to standard pipe flanges on the inlet and discharge nozzles. Figure 1b shows this pump mounted on the original dc aircraft motor used on the KB29 airplane, transferred to a 60-Hz, 3-phase motor but still with the original flanges. Figure 1c shows the full commercial cryogenic configuration with ANSI



**FIGURE 1B** DC-motor-driven refueling pump with original flanges (J. C. Carter Company, Inc.)



**FIGURE 1C** Full commercial cryogenics configuration of dc-motor-driven refueling pump with ANSI flanges (J. C. Carter Company, Inc.)



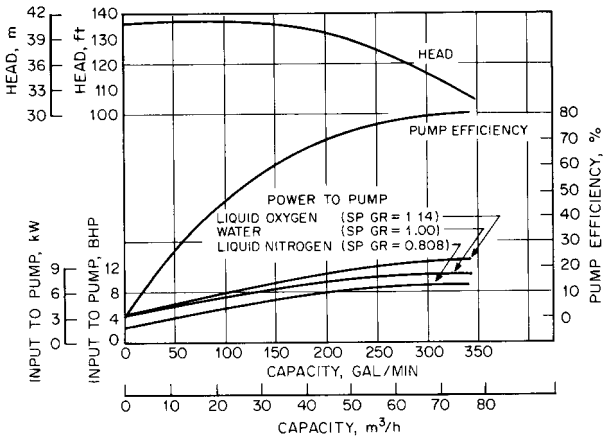


FIGURE 2 Performance characteristics for a refueling pump at 3500 rpm (J. C. Company, Inc.)

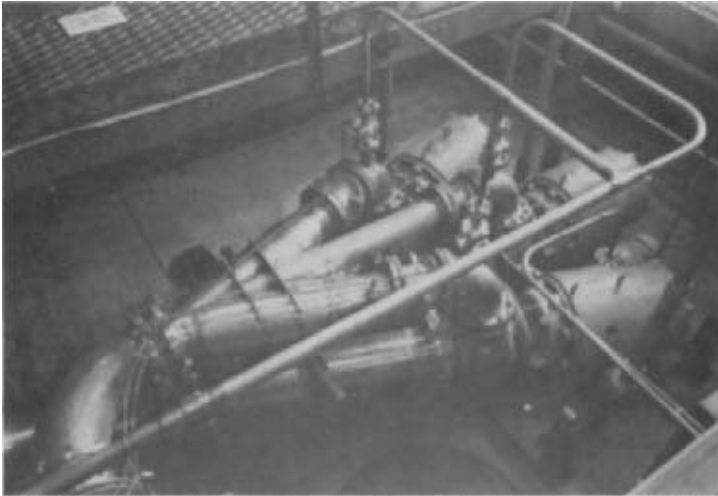
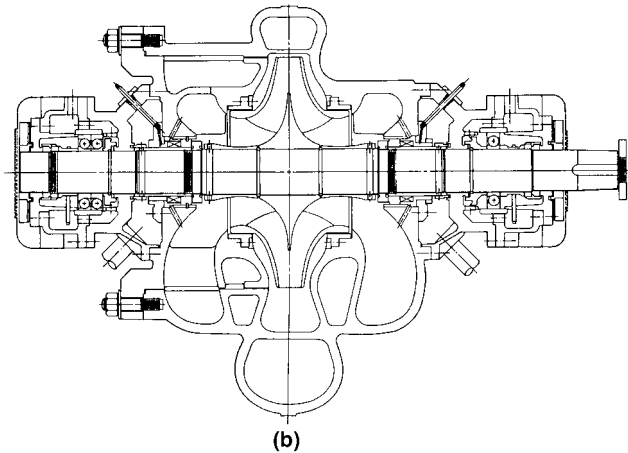
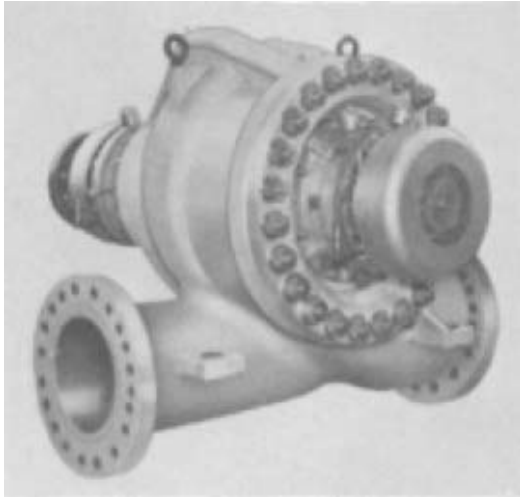


FIGURE 3 Cryogenic pumps for loading liquid-propelled ICBMs (J. C. Company, Inc.)

standard flanges and stainless steel thermal barrier/distance piece for mounting the pump onto the motor. The pump, originally designed under the space and weight limitations of aircraft service, also fit the requirements of cryogenic pumping in that the low heat capacity and surface area resulted in short cool-down time and low heat leak. Because the pump was also very efficient (Figure 2), the boiloff problem was greatly alleviated. The gas industry welcomed this pump, and it became one of the most popular transfer pumps for loading and unloading tank cars and trailers.

Following the lead set by this pump, several other small manufacturers began building similar pumps. As the industry grew, pumps of larger capacity and higher heads were built, covering the range from 4 gpm (0.9 m<sup>3</sup>/h), used in transferring liquid from rectifier columns to storage, to more than 5000 gpm (1125 m<sup>3</sup>/h), used for loading the early liquid-propelled ICBMs during the 1960s (Figure 3). Only one of these latter systems was built. The pumps shown in Figure 3 were about the largest end-suction close-



**FIGURE 4** (a) Double-suction cryogenic pump, (b) cross-sectional view (Flowsolve Corporation)

coupled pumps ever built. The pump built to load the Saturn rocket at 10,000 gpm (2250 m<sup>3</sup>/h) was not close-coupled and was possibly the only double-suction cryogenic pump ever built (Figure 4).

### **LIQUEFIED HYDROCARBON GASES**

The cryogenic fluids encountered in this service are primarily LNG (a mixture that is normally more than 90% methane), ethylene, and ethane, along with the liquefied petroleum gases (LPG) propane and butane. A novel approach to pumping these fluids was introduced in 1959 with the application of the submerged electric-motor-driven pump. Because these fluids are excellent dielectrics, part of the pumped fluid stream can be directed

through the motor to cool it and lubricate the bearings. There is no need to can or treat the windings with anything other than specially selected varnishes. Many advantages accrue to this design, such as

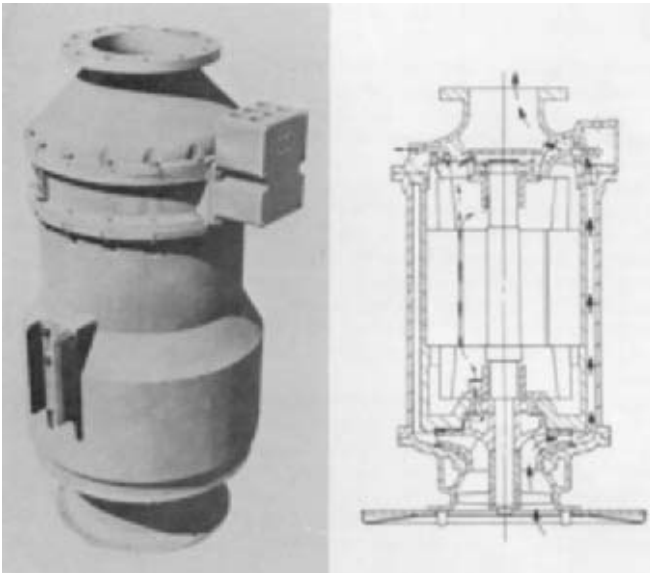
- No cool-down requirement on pumps installed in tanks
- High inherent reliability due to protection from corrosion and humidity and elimination of shaft seal
- Low hazard due to 100% rich environment
- Minimal differential shrinkage problems
- Capability of directing rejected heat in accordance with designer's wishes

Also, the pump is close-coupled to the motor, eliminating the need for a long line shaft, line shaft bearing problems, and differential shrinkage problems. As a result, higher speeds can be used and pumps can be smaller and less expensive.

This construction has found many applications that have led to a variety of configurations, including the single and multistage units used in the liquefaction process plant to transfer to storage, load and unload cargo ships, and pump to high pressures for regasification. The pumps can be mounted in tubes inside the tanks so they can be removed for service through the roof without emptying the tank, thus eliminating the need for an opening in the bottom of the tank. They are also mounted in suction barrels that can be maintained cold indefinitely on instant standby.

A typical cargo pump for use on board ships is shown in Figure 5. This pump uses aluminum castings for all housings as well as for the pump impeller. The motor uses electrical iron laminations, a stainless steel shaft, and stainless steel ball bearings with special nonmetallic separators. The path of the top wear ring flow up through the motor and back into the tank is easily seen.

This pump stands about 5 ft (1.5 m) high from the suction flange to the discharge flange. Flow is typically in the 5000-gpm (1125-m<sup>3</sup>/h) range. Motors with ratings up to 450 hp (336 kW) are available.



**FIGURE 5** On-board cryogenic cargo pumps—photograph on left and cross-section on right showing flow through the motor (J.C. Carter Company, Inc.)



**FIGURE 6** Ship-loading cryogenic pump (J.C. Carter Company, Inc.)



**FIGURE 7** Multistage cryogenic pump on test stand (J.C. Carter Company, Inc.)

Other configurations are shown in Figures 6 and 7. Figure 6 is a typical ship-loading pump provided with an 800-hp (597 kW) motor and capable of pumping more than 20,000 gpm (4500 m<sup>3</sup>/h). This type of pump is designed for mounting in a suction pot. Figure 7



**FIGURE 8** Multistage variable geometry expander on test stand (Flowserve Corporation)

shows a 1200-hp (894 kW) multistage pump being removed from the test tank. Pumps such as this are capable of more than  $1000 \text{ lb/in}^2$  ( $69 \text{ bar}^1$ ) discharge pressure pumping LNG and are in service with motors of 2500 hp (1860 kW).

Many users are migrating toward the vertical canned-style pump for critical LNG services. Liquefied gas producers are keenly aware of the high reliability and capability of immediate start-up these vertical units offer. These pumps are used more often for continuous process service than for standby service that merely backs up gas compressors. There is a trend in this industry toward an increase in flows and pressures—up to 4000 ft (1220 m). The vertical canned-style pump provides space saving, a neat installation, and superior suction performance when there is little net positive suction head (*NPSH*) available.

The LNG and liquefied air industries utilize both fixed- and variable-geometry, multistage vertical turbines (Figure 8). These units are referred to as expanders in the LNG industry and dense fluid expanders (DFEs) in the air separation industry. The units are

<sup>1</sup>1 bar =  $10^5$  Pa.

capable of breaking down pressure in a product flowstream or a closed refrigeration loop very efficiently as compared to a common pressure breakdown (control) valve. Expanders dramatically increase overall plant process efficiency and can actually lower initial plant construction costs by allowing downsizing of main compressors. The expanders break down the product efficiently, produce electricity as a by-product, and allow for vaporization of the product. The amount of sellable product increases by up to 5% when utilizing expanders rather than valves to break down the flowstream pressure. Payback periods of 6 to 12 months are common.

## **ENGINEERING PROBLEMS**

---

The pumps described in the preceding pages, although widely diverse in configuration, still have a number of common problems. First, there is the extreme, paralyzing cold. It is small wonder that the early pumps were considered successful when they did not freeze into immobility. The cold penetrated the motor, causing grease-lubricated bearings to seize and filling the inside of the motor with ice that locked the rotor fan blades and kept them from turning. The piping attached to the pumps shrank, distorting the pump casings into heavy rubbing contact with the impeller. Frost and ice entered the external side of the seal, immobilizing it so that leakage was uncontrollable. It was difficult to find materials for construction that did not become unusually brittle, and there were almost no data available on the total shrinkage of common materials at cryogenic temperatures.

Sources of data on the properties of materials at low temperatures are listed at the end of this section.

Other problems resulting from low-temperature operation are mainly mechanical and are surmounted by using thermal barriers, flexible sections of piping, and dry purge gas to prevent the ingress of moist air. Gasketing and lubrication problems are both currently being solved by materials that did not exist when the problems were originally encountered.

One common problem has to do with the characteristics of the fluids being pumped. Cryogenic fluids are stored in insulated tanks maintained at pressures only slightly above atmospheric, and the fluids become saturated at the storage pressure. Because it is not possible to obtain any pump elevation relative to the tank bottom, net positive suction head becomes a real problem. Various style of inducers have been used to improve the suction performance of the pumps, but in nearly all cases some degradation of performance must be anticipated as the tank is drawn down to low levels and cavitation operation is inevitable. Fortunately, operation in cavitation is not as severe a problem in cryogenic fluids as it is in water, because of the much lower energy of the cryogenic fluid bubble, and so severe cavitation damage to pump parts is seldom encountered.

Testing of pumps for cryogenic service is difficult and requires a heavy investment in test loop equipment. It is also fraught with problems that are peculiar to testing and will not be present in actual operation. One such problem has to do with the recirculation operation in a test loop. The work put into a saturated fluid is usually released by allowing some of the fluid to boil away. Because it proves nearly impossible to extract all the vapor from the liquid, the test fluid specific gravity effectively decreases by an unknown amount. This makes it difficult to establish the exact performance that has been obtained because the data will be lower than true values based on the specific gravity of the unadulterated fluid. It has been found with careful testing that exact duplication of water head-capacity performance will be obtained on any cryogenic fluid, subject only to adjustment for the shrinkage in impeller diameter.

## **REFERENCES AND FURTHER READING**

---

ASTM Special Technical Bulletin No. 302. "Symposium on Evaluation of Metallic Materials in Design for Low-Temperature Service." 64th Annual Meeting, Atlantic City, NJ, June, 1961, American Society of Testing and Materials, 1916 Race St., Philadelphia, PA 19103.

ASTM Special Technical Publication No. 78. "Symposium on Effects of Low Temperatures on the Properties of Materials." March 1946, American Society of Testing and Materials, 1916 Race St., Philadelphia, PA 19103.

"Effects of Low Temperature on Structural Metals." NASA SP-5012, December 1964, National Aeronautics and Space Administration, Washington, D.C.

"The Nil Ductility Transition Temperature of Cast Steels." August 1971, Technical Research Committee (Peter F. Weiser, Research Director), Steel Founders' Society of America, Rocky River, OH, 44116.

Stephens, R. I. "Fatigue at Low Temperatures." ASTM Special Publication 857, American Society for Testing and Materials, 1916 Race St., Philadelphia, PA 19103, May, 1983.

"The Toughness of Cast Steels—NDTT, Charpy V-Notch and Dynamic Tear Tests." Research Report No. 80, May, 1974, Carbon and Low Alloy Steel Technical Research Committee (Peter F. Weiser, Research Director), Steel Founders' Society of America, Rocky River, OH 44116.

---

# SECTION 9.19

---

# AEROSPACE

---

## 9.19.1

### AIRCRAFT FUEL PUMPS

J. E. CYGNOR

The operating characteristics and reliability of aircraft fuel pumps are absolutely critical with respect to the performance and the safety of flight of today's gas turbine-powered commercial and military aircraft. With a large commercial airliner carrying upwards of 50,000 gallons (189,000 liters) of fuel on a long range flight, making fuel the single heaviest load the aircraft must handle, the importance of intelligent and safe processing of this fuel load is clearly evident.

The aircraft fuel pump system is divided into two separate but related systems: the airframe fuel pump system and the engine fuel pump system. Two systems are required because of the significantly different functional requirements of each system. The airframe system is a low pressure system that operates continuously at low values of inlet *NPSH* and utilizes booster pumps located throughout the airframe fuel system to supply pressurized vapor free fuel to the engine fuel system. The engine fuel system is a high-pressure system that further pressurizes the fuel for delivery to the engine combustor fuel nozzles and other engine systems. The requirements of these systems and the pumps in them are covered by a wide range of government and industry specifications. Minimally, these define the performance, fuel types, operating and ambient conditions, drive source, reliability, life, weight, installation, quality, materials, and test requirements to which the fuel pump must conform.

The detailed nature of these specifications further emphasizes the critical nature of aircraft fuel pumps. The fuel pump designer's task is to provide fuel pumps that meet these specifications with the lowest weight, best efficiency, and at a competitive cost. Both centrifugal and positive displacement types of pumps are used in performing the necessary fuel pumping functions on essentially all large gas turbine-powered aircraft.

Because of the specific installation and performance requirements for airframe and engine fuel pumps, each pump is an individual and custom design for each specific application. As such, there are no catalogue type standard pump configurations or designs for aircraft applications.



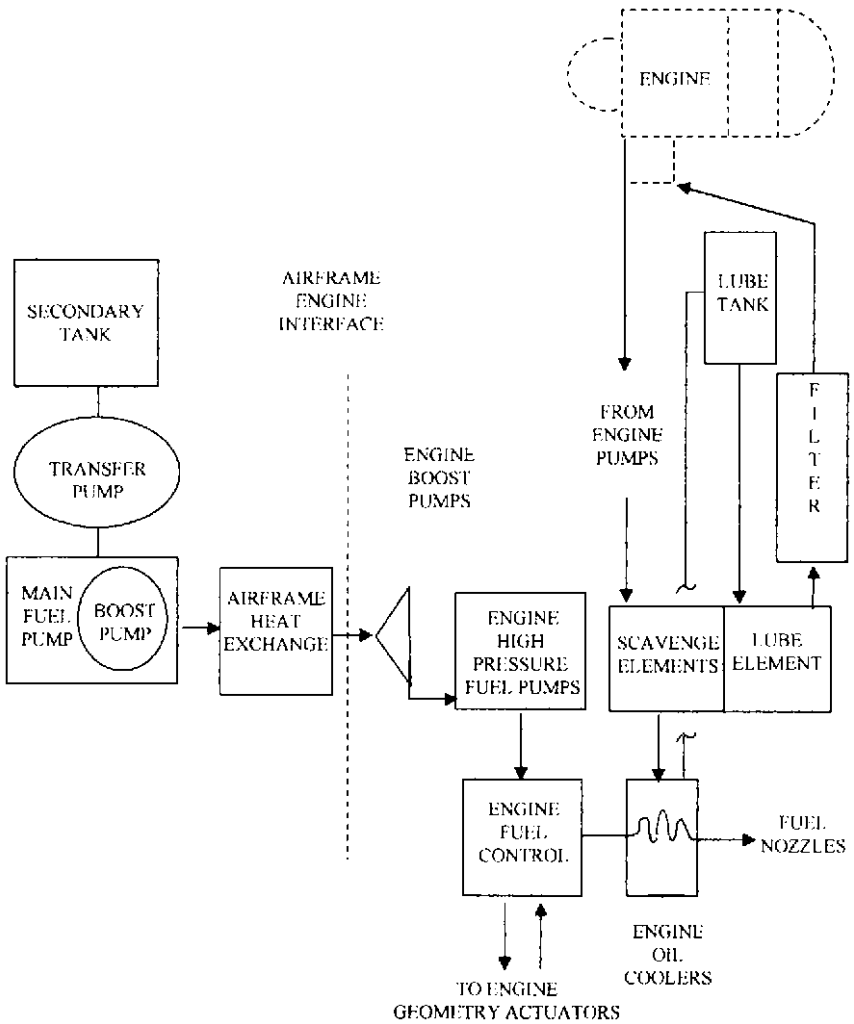


FIGURE 1 Basic schematic of fuel system

## OVERALL AIRCRAFT FUEL SYSTEM

Figure 1 presents a basic schematic of the fuel pump components in the overall aircraft fuel system. The division between the airframe and engine systems is shown.

The primary function of the airframe fuel system is to provide a pressurized fuel feed to the engine fuel pump system under all operating conditions. In the event of the emergency conditions of non-operating or failed boost pumps, a bypass located either in the airframe plumbing or the boost pump allows the engine pump system to receive sufficient fuel to provide take-off and climb thrust. Other functions required of the airframe fuel pump system are as follows:

- Provides fuel transfer between various fuel tanks to maintain continuous engine feed and to adjust the center of gravity of the aircraft.
- Provides fuel jettison in flight in the event it is necessary to quickly reduce the aircraft weight.
- Assists in the defueling of the aircraft on the ground.

The primary function of the engine fuel system is to receive the fuel from the airframe fuel system, under normally pressurized conditions or emergency conditions, and provide pressurized fuel to the engine. This fuel is used for burning in the combustors and for powering actuators that control the engine's variable geometry.

Because fuel is the only consumable fluid carried by the aircraft, it represents the sole heat sink on board the aircraft. (For extreme conditions, some aircraft have carried an additional disposable heat sink fluid.) The on-board fuel and the air ingested by the engines or scoops provide all of the cooling necessary for the proper functioning of the various airframe and engine systems. The impact of this on the fuel pumps is a significant increase in the temperature of the fuel on which the pumps must operate.

### **GENERAL DISCUSSION OF AIRFRAME FUEL PUMPS**

---

The primary type of pump used for providing the fuel boost and fuel transfer functions on an airframe is a centrifugal pump element driven by a fuel-flooded AC induction electric motor. Positive displacement elements are rarely used and alternate drive means such as hydraulic motors and air or fuel driven turbines have only been used on a selected few military aircraft. On small general aviation aircraft, jet pumps with the motive flow provided by the engine fuel pump are popular.

Helicopters commonly incorporate a special type of fuel system called a "suction feed" fuel system. Because a helicopter is altitude-limited, it is not necessary to provide a pressurized engine fuel inlet condition. In fact, for safety considerations, it is desirable not to pressurize the fuel lines between the fuel tanks, located in the lower sections of the airframe, and the engines, which are located in the upper sections of the airframe. For these applications, the engine fuel pumps are designed to continuously operate with a fuel inlet pressure lower than the fuel tank pressure by the height of the fuel lift between the fuel tank and the engine and the incurred fuel line pressure losses.

The standard electric power on aircraft is 400 Hertz, three-phase 115-volt line to neutral/200 volt line to line type. This type of power has been selected to minimize the weight and size of the total aircraft electrical system.

Various inlet configurations are used on airframe fuel boost pumps depending upon the configuration of the fuel tanks and the flight conditions under which the pump must operate. Figure 2 presents illustrations of some of the most common configurations.

The two configurations labeled "single attitude" are applicable to commercial airlines and transport-type aircraft. In these applications, only positive "G" loads are experienced; so the fuel location in the tank is always downward in the illustrations. Depending upon the fuel tank configuration and airframe structural requirements, either a tank bottom mount location or a snorkel-type fuel inlet is commonly employed. The bottom mount configuration results in the least complex pump configuration because when the pump inlet is covered with fuel, the pump is automatically primed.

With the snorkel-type inlet, some means must be provided within the fuel pump to evacuate the inlet line to prime the centrifugal element after the inlet to the snorkel is covered. This is most commonly provided by a liquid ring type-pumping element (see Reference 20 of Section 2.1) contained within the fuel pump.

For aircraft that will experience negative "G" and zero "G" conditions in flight operations, such as military tactical aircraft, the fuel may be located at the top, bottom, or anywhere in-between within the fuel tank. The configurations labeled negative "G"-capable in Figure 2 are applicable to these types of aircraft. Aircraft that are capable of the most extreme flight maneuvers generally use the dual impeller configuration. With this type of

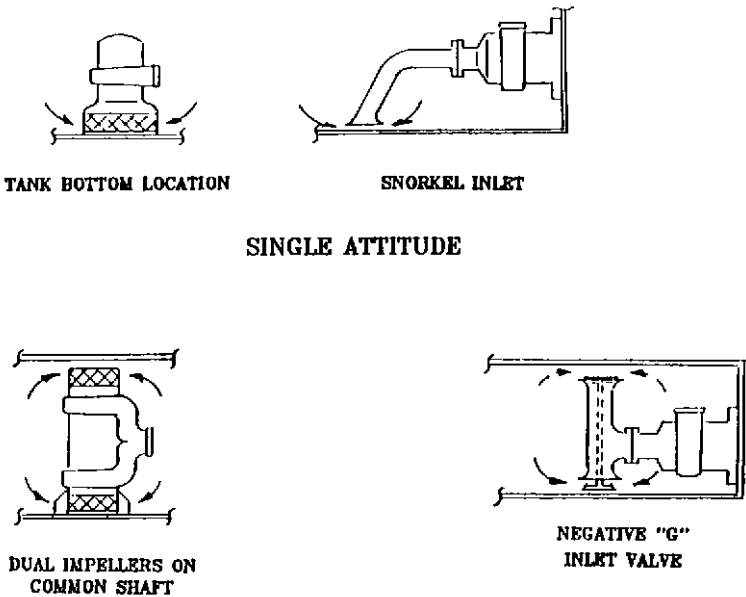


FIGURE 2 Airframe boost pumps—inlet types

pump, the response to negative "G" forces is essentially instantaneous, and full engine fuel flow is provided under all flight conditions. For aircraft with less demanding flight conditions, a pump with a single impeller and a negative "G" shuttle type inlet valve to ensure that only the primed inlet is connected to the impeller is commonly used. The number of pumps, the position of the pumps, and the configuration of the fuel tank are selected to ensure adequate fuel flow is delivered to the engines under all flight attitudes.

### **DESCRIPTION OF THE DESIGN OF AIRFRAME BOOST PUMPS**

Figures 3 and 4 present a cross section view and a photograph of an electric motor-driven boost pump assembly that is used on a commercial airliner. This pump utilizes a snorkel inlet. The design of this pump incorporates cartridge type pump and discharge valve modules that greatly enhances the maintainability of these pumps. The elliptical shaped main housing is a semi-permanent assembly in the airframe fuel tank. The pump modules are easily removable from it without draining the fuel tank through an interlocking inlet valve mechanism that is actuated by the removal action of the pump modules. Except for a screwdriver to remove the cover plate, no tools are required for this maintenance function. The removal of the discharge valve modules are similarly enhanced by this type of design. The immense fuel loads carried by commercial airliners clearly emphasizes the desirability of these maintenance features.

In the interest of weight, all of the housing and structure of the pump assembly are made out of aluminum. Steel is used for high stress parts such as shafts and fasteners and the electric motor laminations. Fuel is circulated throughout the pump cartridge to lubri-

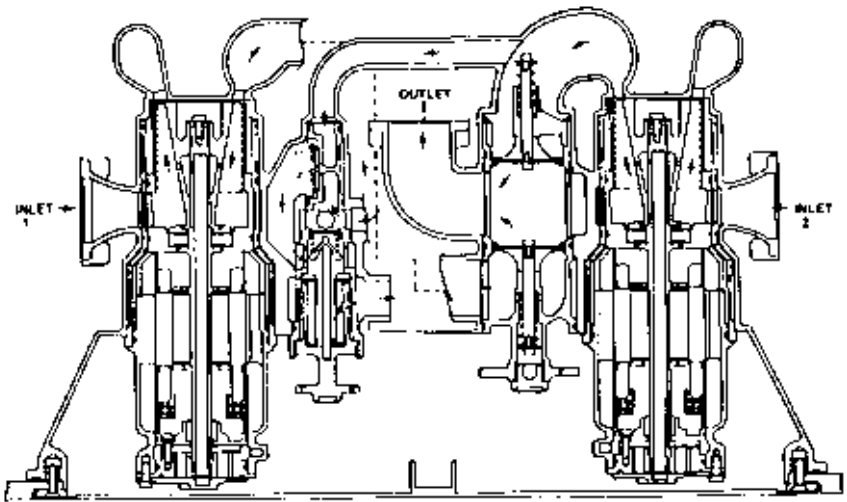


FIGURE 3 Main boost pump flow schematic (Courtesy Sundstrand Corporation)

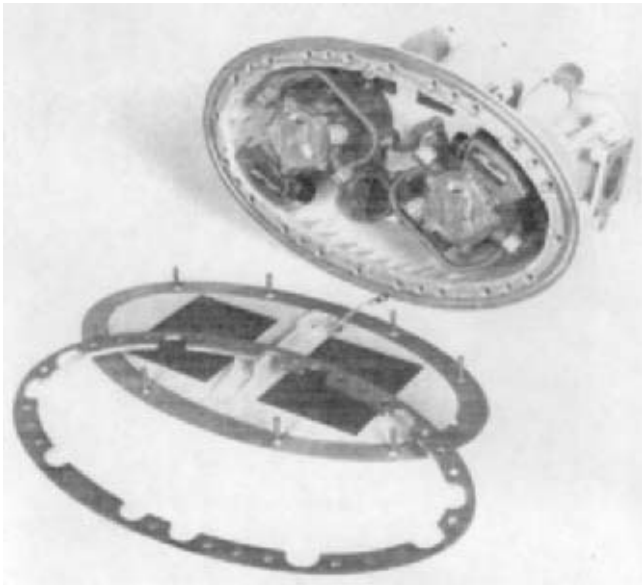


FIGURE 4 Main boost pump assembly (Courtesy Hamilton Sundstrand)

cate the bearings and cool the motor. This fuel is returned to the tank through a port that incorporates a flame arrester.

In the normal operation of the aircraft, fuel tanks will be run dry by the selective usage of fuel from the various fuel tanks to maintain aircraft balance. Under these conditions,

the fuel pumps in these tanks will run dry. To simplify the management of the fuel system, it is normal practice to let the pumps run dry for the remainder of the flight. It is therefore necessary to provide a bearing system for the pump, which will accept continuous dry running without detrimental results to the pumps. This is generally accomplished through special configurations of carbon journal and thrust bearings with chrome plated journal and thrust running surfaces.

Because these pumps are located in the aircraft fuel tanks and are totally immersed in fuel, their safety and explosion-proof features are of utmost importance. All openings that communicate the pump electric motor cavity with the interior of the fuel tank must incorporate flame-arresting features. This includes communication through the pumping elements to the pump inlet. Also non-resettable thermal fuses are incorporated in the motor end turns to ensure the motor is disconnected before it can reach the minimum auto-ignition temperature of jet fuel (approximately 390°F/199°C) through various failure modes. It is general practice to provide two electrical insulation barriers between all points of different electrical potential.

Electric motor driven boost pumps are in use in sizes up to 200 gpm (45.42 m<sup>3</sup>/h) flow and at pressure rises ranging from 10 to 50 lb/in<sup>2</sup> (.69 to 3.45 bar) with a motor out power of up to 6.5 hp (4.85 kw).

Electric motors of 8, 6, and 4 poles designs are in general use. The synchronous speeds of the motors with 400 Hertz power are 6000, 8000, and 12000 rpm respectively. The constant demand for smaller and lighter components has seen the increased application of 6- and 4-pole motors in recent years.

The overall weight per pump element (impeller, motor and housings) ranges from 7 to 25 pounds (3.17 to 11.34 kg). The number of pump elements used on large commercial aircraft in service today ranges from four to sixteen.

## **PERFORMANCE CRITERIA OF AIRFRAME BOOST PUMPS** \_\_\_\_\_

The fact that aircraft boost pumps operate at very low net positive suction heads is evident in their operating environment. Fuel tanks are vented to ambient pressure and commercial airlines fly up to 45,000 foot altitudes where the standard atmospheric pressure is 2.14 lb/in<sup>2</sup> (.148 bar). Altitudes are even greater for supersonic aircraft. Tank pressurization above the ambient pressure is employed only on some specialized military aircraft.

The performance criteria that specifically define the design of the centrifugal pumping element in an airframe boost pump are presented in the following discussions.

## **MAXIMUM/MINIMUM PRESSURE RISE AND MOTOR SPEED** \_\_\_\_\_

The pressure rise limits of the pump are defined by the pump specification and are determined by airframe and engine system needs.

The motor speed (that is, the number of poles) is selected by the pump designer to be compatible with the overall requirements of the pump, in particular the altitude requirements. Because of the need to minimize size and weight, the maximum possible speed is employed. This has, in recent years, resulted in the almost exclusive use of axial inducers in airframe boost pumps. They are used either alone, as purely axial pumping elements, or in conjunction with mixed-flow sections depending upon the flow and pressure requirements. Axial inducers are a pumping element that have proven to provide the best suction performance because of their low blade loading and gradual pressure rise characteristic. The inducers on airframe boost pumps incorporate features such as blade sweep back, blended suction surfaces, and thin blade inlet edges. The inlet blade angle at the tip usually ranges from eight to ten degrees measured from a plane perpendicular to the axis of rotation. These pump elements have demonstrated the capability of operating at suction-specific speeds in excess of 40,000 measured in units of gpm, feet of fluid, and rpm (that is, the universal suction specific speed  $\Omega_{ss}$  exceeds 14.6).

## FUEL TYPE

---

Two types of fuels are in general use worldwide in aircraft gas turbine engines. They are referred to as “wide cut fuels” and “kerosene-based fuels.”

Both types of fuel are composed of a complex mixture of a range of individual hydrocarbon compounds. As the name suggests, the wide cut fuels have a wider range of hydrocarbons than kerosene-based fuels. The composition of the fuel is controlled, rather loosely, by the fuel specifications through defining limits on such factors as distillation range, density, flash temperature, heat of combustion, vapor pressure, freezing point, additives, and limits on certain compounds. Wide cut fuels are characterized by relatively low density, low freezing point ( $-65^{\circ}\text{F}/-53.9^{\circ}\text{C}$ ), high vapor pressure and low flash point ( $-45^{\circ}\text{F}/-42.8^{\circ}\text{C}$ ). Kerosene-based fuels on the other hand are characterized by a relatively high density, higher freezing point ( $-40^{\circ}\text{F}/-40^{\circ}\text{C}$ ), low vapor pressure, and high flash point ( $140^{\circ}\text{F}/60^{\circ}\text{C}$ ). The United States designations for wide cut fuels for commercial and military uses are Jet B and JP-4 respectively. The designations for kerosene-based fuels are Jet A1 for commercial uses and JP-5 and JP-8 for military uses. Jet A1 predominates in production because of the huge demands of the airlines. Jet A1 is used in commercial service worldwide primarily for safety reasons because of its high flash point. Jet B is only used when its low freezing point is required; for example, in northern Canada in the winter. The U.S. Air Force previously used JP-4 as their standard fuel, but for availability and safety reasons have switched to JP-8, which is a military version of Jet A1. The navy uses JP-5 because of its high flash point for safety considerations on board aircraft carriers.

The knowledge of the true vapor pressure of the fuel used is necessary in the design and test evaluation of the centrifugal pump element. Because the fuels are a mixture of a range of hydrocarbons, the direct determination of the true vapor pressure is difficult. It is determined indirectly, for a desired temperature, through the Reid Vapor Pressure (RVP). The RVP is an average vapor pressure determined under a defined set of conditions, established by test at  $100^{\circ}\text{F}$  ( $38^{\circ}\text{C}$ ). The True Vapor Pressure (TVP) at this temperature is slightly higher than the RVP. Moreover, the TVP-versus-temperature relationship is determined by the RVP (see Reference 1).

Another key property of the fuel that directly influences the design and performance of airframe boost pumps is the solubility of air in the fuel. This is defined by Henry's law through a solubility coefficient. The ullage volume above the fuel in the aircraft tanks is generally vented to the ambient pressure. The maximum amount of dissolved air in the fuel will occur on the ground. The fuel will be in an air-saturated condition.

Any reduction in the pressure of the fuel will result in the release of this air in accordance with Henry's law and expansion of this air to a volume in accordance with Dalton's law of partial pressures. In addition, as the pressure is reduced, the vapor pressure of the light end hydrocarbon constituents of the fuel is reached. They too will vaporize, adding to the volume of vapor evolved. Reference 1 provides a detailed review of all of the properties of aircraft gas turbine engine fuels.

## ALTITUDE CLIMB PERFORMANCE

---

The altitude climb performance required of an airframe boost pump is specified in terms of altitude achieved versus time in minutes, flow required with respect to altitude, the fuel tank temperature with respect to altitude, and the minimum pump pressure rise required versus altitude. The temperature versus altitude represents the cooling of the fuel through heat transfer to the cold ambient atmosphere and boiling of the fuel that is experienced in a climb event.

Immediately upon take-off, as the aircraft gains altitude, the dissolved air in the fuel will begin to evolve. The rate of this air evolution will depend upon the climb rate of the aircraft. Presently, there is no accurate way to determine this rate of air evolution. This volume of evolved air is handled in the design of the pump by judicious oversizing of the inlet based upon experience and empirical design parameters. Further assistance in handling the volume of vapor is provided in tank bottom mount pumps through pump element

inlet tip vapor vents and discharge hub vapor vents. Snorkel inlet pumps can receive vapor handling assistance through the liquid ring reprime element. Any remaining air and fuel vapor mixture is compressed as it passes through the increasing pressure within the inducer and is redissolved into the fuel. Therefore, the pressurized fuel delivered to the engine is free of vapor.

As the altitude increases, a tank pressure will be reached that will equal the vapor pressure of the fuel. At this point, especially with wide cut fuels, the vapor release will become quite violent (boiling). Here, the rate of vapor evolution will be determined by the capacity of the tank vent system. As the light ends leave the fuel, the vapor pressure of the fuel will decrease. This is referred to as "weathering" of the fuel. After the maximum cruise altitude is reached, the vapor pressure of the fuel will reach equilibrium with the altitude pressure.

The altitude climb test is the most difficult test to perform on airframe boost pumps because it must be a single fuel pass test without recirculation to accurately reproduce an actual climb condition. This requires approximately 1500 gallons (5,680 liters) of fuel for one test on an average commercial airliner fuel boost pump element. Figure 5 presents the results of an altitude climb test on the fuel boost pump depicted in Figures 3 and 4.

### **CONSTANT ALTITUDE PERFORMANCE**

---

This requirement for an airframe boost pump is specified in terms of a required fuel flow range at a given temperature and at a constant altitude. The minimum required pressure rise is also specified. The submergence of the inlet of the pump (for bottom mount types) or the snorkel inlet (for snorkel inlet types) is also defined and is measured in the range of a few inches. For altitude pressures lower than the initial fuel vapor pressure, the fuel is weathered to achieve equilibrium with the altitude pressure. The fuel is recirculated in this test. Figure 6 presents the constant altitude performance of the fuel boost pump depicted in Figures 3 and 4.

### **GENERAL DISCUSSION OF ENGINE FUEL PUMPS**

---

The primary fuel pump used for providing the boost and high-pressure fuel pumping function for an engine is called the "main fuel pump." It is engine gearbox-mounted and driven. In its most common form, it includes a positive displacement external spur gear high-pressure stage and an integral centrifugal boost stage. This type of pump is exclusively used on all modern commercial airliner engines and supplies all of the fuel flow requirements of the engine combustors. On commercial airliner engines, the main fuel pump is the sole engine fuel pump and therefore is a prime reliability piece of equipment. All engines, commercial and military, have a main fuel pump.

Positive displacement pumps have certain operating characteristics that make them very adaptable to aircraft gas turbine engine fuel systems. These characteristics include the ability to reprime from a completely dry condition and the ability to deliver useful fuel pressure over a wide speed range. Engine control systems utilize a portion of the main fuel pump discharge flow to power the actuation systems for fuel burn flow metering and engine variable geometry control for all operating conditions. Corner point operating conditions, such as altitude re-light and ground starting, occur at 8 to 10 percent of rated operating speed. The pressure required for actuator muscle and response characteristics at these conditions is generally a 250 lb/in<sup>2</sup> (17.2 bar) pressure rise. At the maximum power take off condition at 100 percent speed, the pressure rise requirement ranges up to 1500 lb/in<sup>2</sup> (103 bar). Positive displacement pumps have proven capable of meeting these needs and the external spur gear pump type has received the widest acceptance from the industry.

The key attribute of the external spur gear main fuel pumps relates to the safety of flight and prime reliability requirements. In over fifty years of experience, this type of

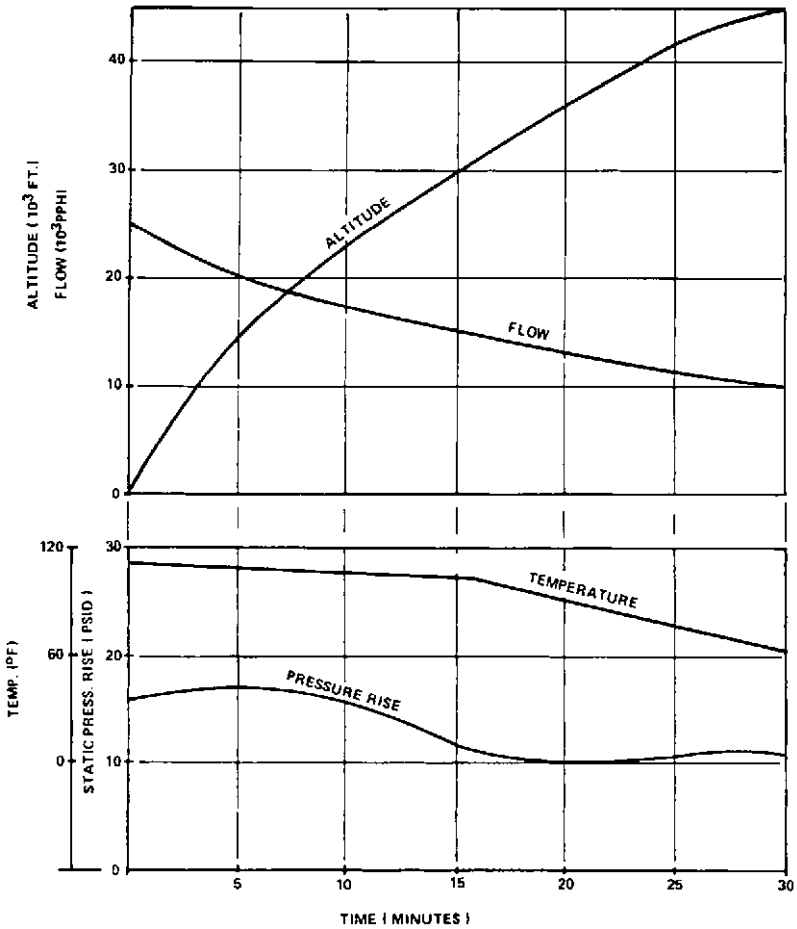


FIGURE 5 Main boost pump altitude climb ( $\text{kg/h} = \text{PPH} \times 0.4536$ ;  $\text{m} = \text{ft} \times 0.3048$ ;  $\text{bar} = \text{psi} \times 0.06895$ ;  $^{\circ}\text{C} = (^{\circ}\text{F} - 32) \times 0.556$ ).

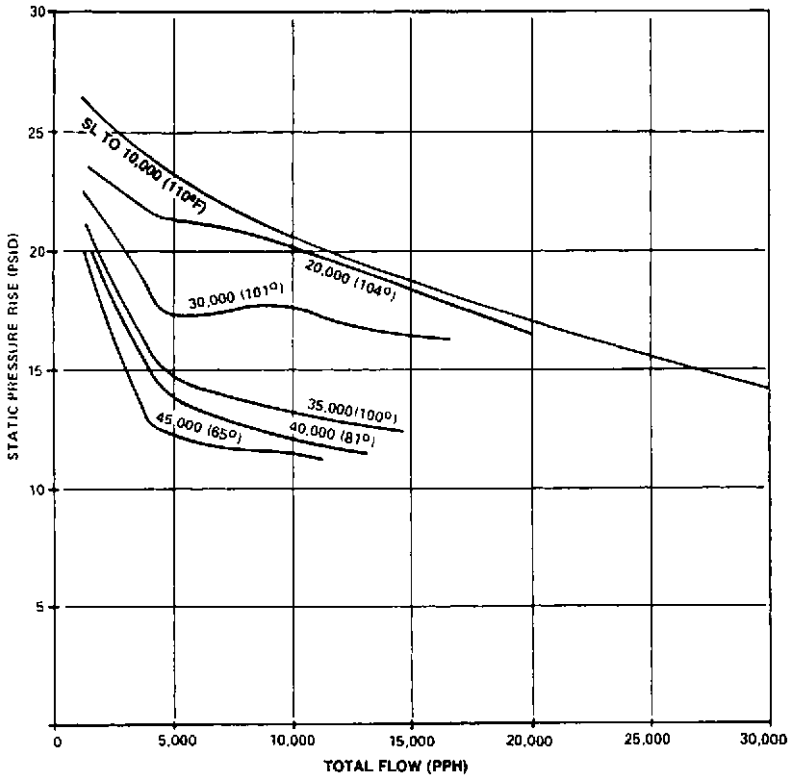
pump has demonstrated a graceful type of failure mode. It does not fail in a catastrophic manner in which it suddenly ceases to function. It slowly, over an extended period of time, degrades in performance until it no longer meets minimum requirements, but continues to function. In commercial service, these pumps routinely operate for over 10,000 flight hours without service or repair.

Table 1 presents the pertinent characteristics of representative external spur gear main fuel pumps.

Other types of positive displacement pumps, such as axial piston and sliding vane pumps, have been applied to engine main fuel pumps. These have not achieved the level of acceptance of external tooth gear pumps.

On highly specialized engines, such as military fighter aircraft engines, additional high-pressure fuel pump functions may be required. These include fuel pumps for supplying the thrust augmentation systems (afterburners) and, in some applications, fuel pressure for the actuation system for the engine's exhaust nozzle. Because augmentation fuel





**FIGURE 6** Main boost pump altitude performance (Altitudes are shown on the curves in ft;  $m = ft \times 0.3048$ ;  $kg/h = PPH \times 0.4536$ ;  $bar = psi \times 0.06895$ ;  $^{\circ}C = (^{\circ}F - 32) \times 0.556$ ).

flows are very high and the systems are operational for only a small percentage of the mission time, high-speed centrifugal pumps are used in these situations. Centrifugal pumps offer a low unit weight and the ability to be run dry when the system is not operating, thereby conserving power. These centrifugal pumps operate at speeds up to 25,000 rpm and deliver up to 200 gpm (45.42  $m^3/h$  at 1000  $lb/in^2$  (69 bar) pressure rise. The fuel actuation function has been provided by variable displacement piston pumps. The fuel boost function for the multiple high-pressure fuel pump engines is usually provided by a single centrifugal boost element either separately mounted on the gearbox or integrated with the main fuel pump.

An alternative drive means has been used for the centrifugal augmentor fuel pump in some applications. An air turbine utilizing engine compressor bleed has been used as a drive source. When the system is non-operational, the pump may be stopped or idled by throttling the turbine inlet air supply, thereby conserving power.

For large engines, such as those used on commercial airlines, the boost stage is a conventional centrifugal element that generally incorporates an axial inducer. For smaller engines used on general aviation and helicopter applications, various specialized centrifugal elements and jet pumps have been used and have shown the capability of meeting the needs of suction feed fuel systems.

As discussed the engine boost pump must function with the airframe boost pump in both the operating and failed, or not operating, conditions. The engine fuel inlet pressure with the airframe boost pumps operational is generally specified over a range from

**TABLE 1** Main fuel pump parameter chart

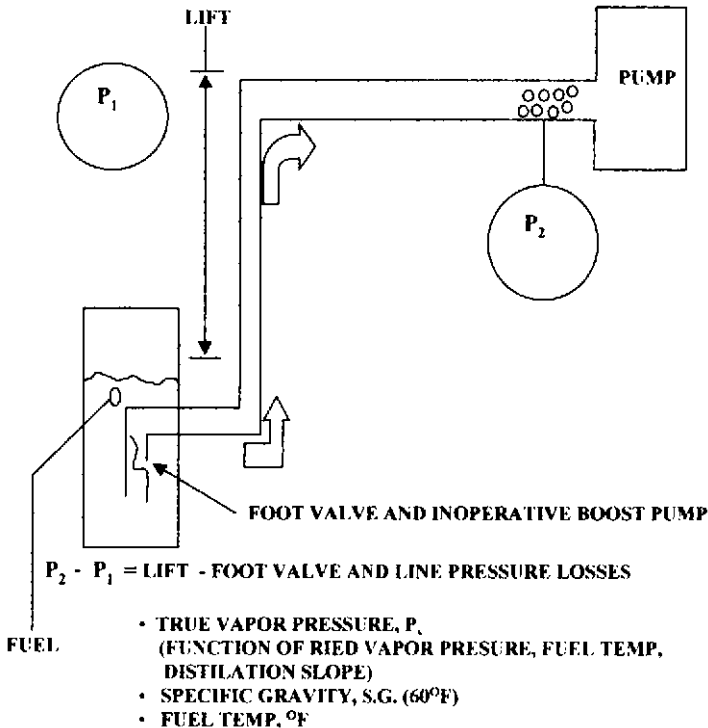
Engine Application and Engine Power	Gear Stage Displacement in <sup>3</sup> /rev (cm <sup>3</sup> /rev)	Rated Input Speed RPM	Rated Output Flow GPM (m <sup>3</sup> /h)	Rated Pressure Rise lb/in <sup>2</sup> (bar)	Unit Weight Pounds (kg)
<ul style="list-style-type: none"> <li>• Commercial Airliner</li> <li>• 68,000 Pounds (302 kN) Of Thrust</li> </ul>	3.487 (57.142)	6270	86 (19.53)	1250 (86.2)	34 (15.42)
<ul style="list-style-type: none"> <li>• Fighter Aircraft</li> <li>• 28,000 Pounds (124 kN) Of Thrust</li> </ul>	2.341 (38.36)	6075	55.2 (12.54)	1390 (95.8)	24.5 (11.11)
<ul style="list-style-type: none"> <li>• Executive Jet</li> <li>• 5,000 Pounds (22 kN) Of Thrust</li> </ul>	.631 (10.34)	6300	15.5 (3.52)	1200 (82.7)	12 (5.44)
<ul style="list-style-type: none"> <li>• Helicopter</li> <li>• 650 H.P. (485 kW)</li> </ul>	.233 (3.818)	4205	4 (.91)	1000 (69)	4.6 (2.09)

50 lb/in<sup>2</sup> (3.45 bar) to 5 lb/in<sup>2</sup> (.345 bar) plus TVP for all engine operating conditions. There are to be no vapor or air bubbles present in the fuel. For the condition of failed, or non-operating, air frame boost pumps, the engine boost pump is required to operate with an inlet vapor-to-liquid volume ratio (V/L) of .45 at the maximum fuel tank temperature for takeoff conditions to at least a 10,000 ft (3048m) altitude (to cover high altitude airports) and appropriate V/L and fuel temperature conditions for maximum continuous thrust conditions up to 45,000 ft (13,716m). The V/L condition occurs because of the line pressure drop that occurs between the fuel tank and the engine boost pump inlet. This is depicted in Figure 7. The value of the V/L ratio is defined as the volume of vapor divided by the volume of fuel. A V/L of .45 represents a void volume ratio of approximately 30 percent.

Because the engine mounted boost pump is line-mounted and is external to the airframe fuel tank, the vapor entrained by the fuel cannot be ejected back to the tank as it is with the tank-mounted airframe pumps. All the vapor must be ingested by the boost pump and be compressed and re-dissolved back into the fuel. If the boost stage becomes overwhelmed by vapor, the vapor will build up at the pump inlet and the system will become vapor locked. This must be absolutely avoided.

The value of .45 for the take-off V/L ratio has been established over the years as a value that will provide adequate vapor lock margin. See Reference 2 for a history of the V/L parameter. Airframe systems are analyzed to ensure the margin is maintained. The reduced usage of wide cut fuels in the future will somewhat relieve this requirement. Figure 8 presents the relationship between V/L and tank altitude. Note that for a constant value of V/L, as the tank altitude level increases, the pump inlet pressure, and therefore its *NPSH*, decreases.

In addition to the magnitude of the V/L ratio and the boost pump *NPSH*, the condition of the multiphase flow is important. To ensure continuous and stable operation of the system, the phases must be well mixed and have equal transport velocities. An operating limit is reached when the phases separate and transport velocities of the vapor phases are less than that of the liquid phase. Under these conditions, vapor will collect at a high point in the system. In time, the system will become unstable if some means of removing this collecting vapor is not provided. A rule of thumb for roughly estimating this transition point is a minimum velocity of 3 ft/sec (1 m/s) for the liquid phase occupying the full diameter of the pipe. For velocities below this level, the probability that phase separation will occur increases. In practice, an adequate mixing of the phases is maintained in pump tests that are run to prove the pump will meet the emergency conditions as previously defined.

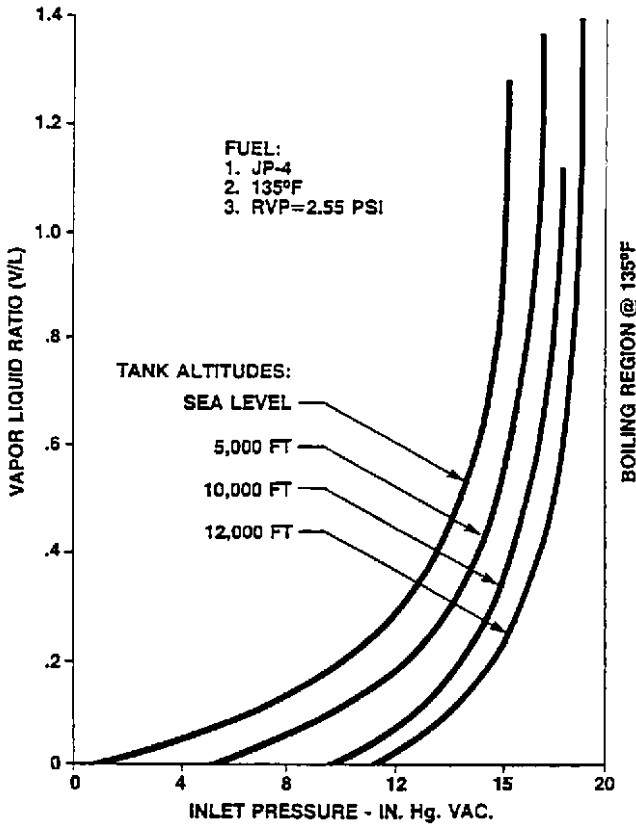


**FIGURE 7** Factors that determine  $V/L$  ratio.  $V/L = O \times (P_1 - P_2)/(P_2 - P_v)$ , where the Ostwald coefficient  $O$  for typical fuels is in the range 0.1 to 0.2, depending upon these factors. Pressures  $P$  are absolute.  
 $[^{\circ}\text{C} = (^{\circ}\text{F} - 32) \times 0.556]$

For the suction-feed fuel systems employed on some helicopters, the uniform mixing of the vapor and liquid phases may not be maintained for all operating conditions. As previously discussed, these systems operate continuously under fuel-vapor-forming pump inlet conditions for all engine operating conditions; that is, from flight idle to maximum contingency power at all altitudes. Depending upon the engine fuel flow requirements, the fuel temperature and type and the fuel line configuration, separation of the liquid and vapor phases may occur. Because of the significant vertical pipe runs in these systems, this separated flow may exist in the form of alternating “slugs” of vapor and liquid flow in the line. When flow conditions of this type occur at the inlet to the engine fuel boost pump, a reserve volume of fuel must be provided within the pump. It is necessary to maintain a continuous flow of liquid fuel to the engine combustors for the time period when the vapor slug is being ingested by the pump and being compressed and redissolved into the fuel. Figure 9 is a pictorial presentation of the potential vapor and liquid flow conditions at the pump inlet. References 3 and 4 present a detailed review of these flow conditions.

### **DESCRIPTION OF THE DESIGN OF MAIN FUEL PUMPS**

In this subsection, the design of a main fuel pump utilizing an external spur gear high-pressure element for application on engines powering modern airliners will be discussed. The designs of main fuel pumps for engines powering other classes of aircraft such as military fighters, executive aircraft, and helicopters are similar and differ mainly in the



**FIGURE 8** Vapor/liquid ratio versus inlet pressure ( $m = ft \times 0.3048$ ;  $bar = psi \times 0.06895$ ;  $^{\circ}C = (^{\circ}F - 32) \times 0.556$ ;  $mm\ Hg = in\ Hg \times 25.4$ )

details of size and specific operating requirements. The flow and component schematic of a typical commercial engine main fuel pump is presented by Figure 10. The components encompassed by the dotted square are contained within the pump. As shown, the fuel from the airframe system enters the boost stage inlet. It then passes through the engine oil-to-fuel cooler where the fuel absorbs rejected engine heat, thereby fulfilling its function as a heat sink. This positioning of the oil-to-fuel cooler also provides the de-icing function for the next component in the system, the engine fuel filter. Using the engine oil-rejected heat for the de-icing function eliminates the need for fuel heaters using engine compressor bleed air as the heat source. These types of systems were used on previous generations of engines incurring weight and engine efficiency penalties.

Fuel filters are usually rated at 10 microns nominal and 40 microns absolute. The minimum filter surface area is usually determined by the worst icing condition. A filter bypass valve is provided to ensure continuous engine fuel flow in the event the filter becomes blocked. An indicator is provided to indicate impending filter bypass so maintenance actions can be initiated.

The fuel then enters the high-pressure gear stage element and is delivered to the engine fuel control unit at a pressure determined by the downstream resistance characteristics. A high-pressure relief valve is utilized for burst protection for the high-pressure components of the fuel system in the event of a downstream blockage.

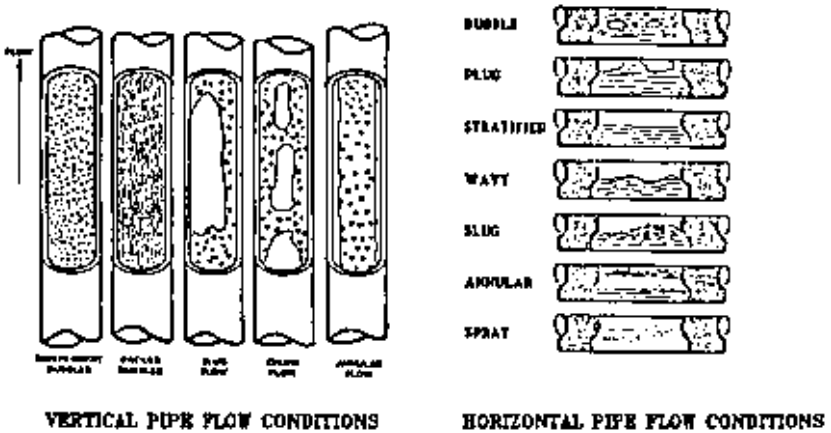


FIGURE 9 Possible multiphase flow conditions at pump inlet

The control of the engine fuel flow is achieved in the fuel control system by bypassing the excess fuel back to the fuel pump upstream of the fuel oil cooler. This returned flow represents waste heat that is proportional to the quantity of the bypassed flow and the pressure differential between the gear stage and boost stage discharge pressures. This waste heat further increases the gear stage fuel inlet temperature.

The volumetric flow characteristics of positive displacement pumps closely match the fuel flow requirements of aircraft gas turbine engines. The ideal volumetric flow rate of a positive displacement pump is directly proportional to its rotational input speed. In actual practice, this is somewhat modified by the internal leakage flows that occur from the high-pressure discharge to the low-pressure inlet. These leakage flows are a combination of flow through the clearances between the pump parts and the necessary bearing lubrication and cooling flows. Also, leakage flows are proportional to the pressure rise across the pump and essentially constant over the operating speed range of the pump. Therefore, the leakage flows are a higher percentage of the ideal flow for lower percentages of rated pump speed. The percentage of the ideal flow that the delivered flow represents is the volumetric efficiency of the pump. Figure 11 depicts the basic relationship between the output characteristics of a positive displacement pump and the engine fuel flow requirements.

As previously discussed, the main fuel pump is required to provide both the engine burn flow requirements and the engine geometry actuation flow requirements. For a given class and type of engine (for example, commercial airline turbo fan engines), the engine geometry actuation flows are usually an essentially constant value for all engine speeds for a given number of actuator servos. Therefore, because of the volumetric characteristics of positive displacement pumps, the displacement sizing point of the high-pressure element for larger engines will tend to be the rated take-off power high pump rotational speed condition. For smaller engines, it will tend to be the starting low pump rotational speed condition. The example in Figure 11 is sized at the starting condition. The disadvantage of this type of pump concept, clearly shown in Figure 11, is the significant over-capacity of the high-pressure element for low engine power conditions such as the idle condition. This over-capacity represents the quantity of waste heat in the form of throttling loss in the bypass control loop that complicates the engine heat management system. The task is to avoid reaching the fuel thermal stability temperature limit (about 325°F/163°C) in the combustor fuel nozzles. Exceeding this limit will result in clogging the nozzles with fuel "coking" deposits. Significant effort has been expended on alleviating this problem through the application of variable displacement pumps. These efforts have not achieved general acceptance because of reliability, safety, and cost disadvantages.

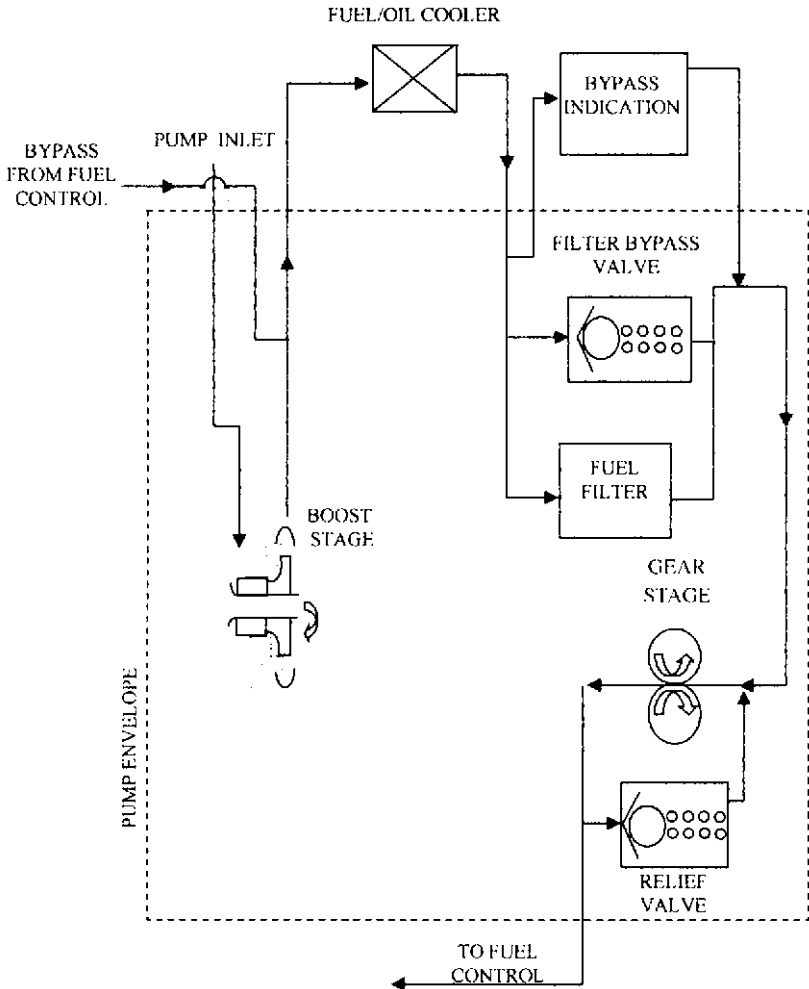


FIGURE 10 Main fuel pump system schematic

Figures 12 and 13 present a photograph and a cross-section of a main fuel pump incorporating an external spur gear high-pressure stage and centrifugal boost stage. The pump is mounted directly to the engine gearbox and the rotational input power is transmitted directly to the spur gear stage by a spline coupling. The boost stage is driven by a secondary splined coupling. The drive priority is selected to reflect the power input order of the elements and that the high-pressure element is the primary pumping element. The housings are aluminum castings that provide the minimum weight and also provide the necessary structural integrity and stiffness for all specified conditions.

A face-type dynamic mechanical shaft seal is provided at the drive end of the pump. A wide range of design configurations have been employed, but all modern pumps utilize the sealing faces as the primary seal and "O" rings for the secondary seal. These seals are required to operate with pressure differentials in both directions. Special design features must be employed to accommodate this requirement. The drive shaft seal is vented to a

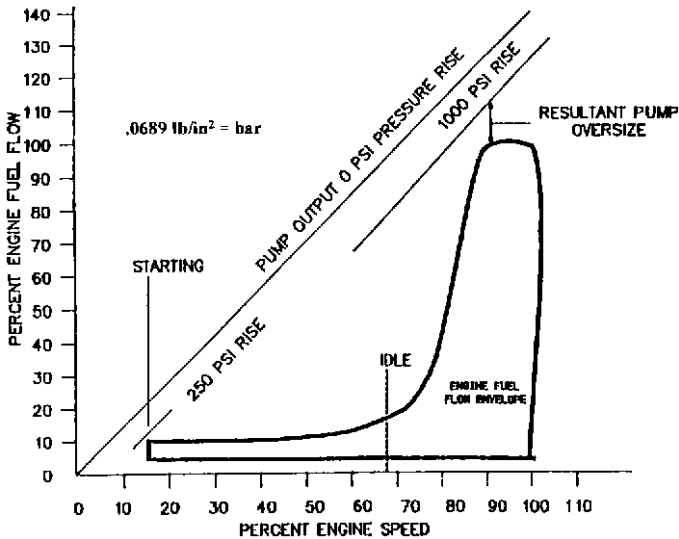


FIGURE 11 Positive displacement pump output characteristic versus engine flow requirements

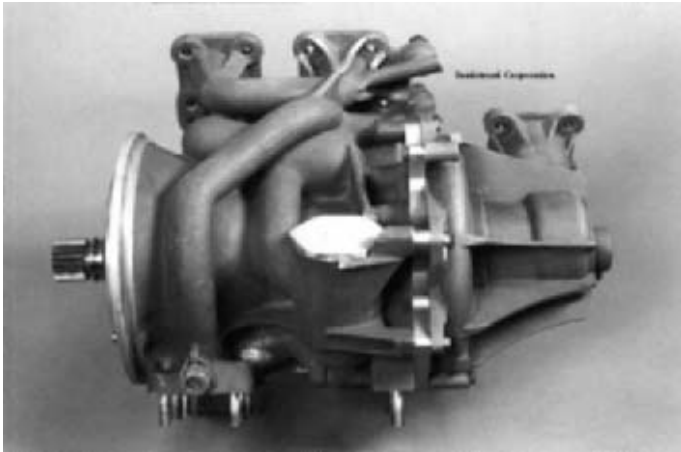


FIGURE 12 Main fuel pump assembly (Courtesy Hamilton Sundstrand)

dry cavity that is connected to the engine overboard drain system. For reasons of safety, all fuel and oil passages separated by seals, static or dynamic, must have double seals with a drain port between them.

The type of external spur gear pump element used in main fuel pumps is the fully pressure-loaded type. Figure 14 depicts the basic details of the configuration used. The six parts shown in Figure 14 are assembled into a figure-eight bore arrangement in the pump housing. The four bearing blocks, which are a slip fit, are pressure-loaded towards the faces of the spur gears, and the assembly as a whole is pressure-loaded towards the inlet side of the housing bores. An initial axial sealing force is provided by springs. The axial

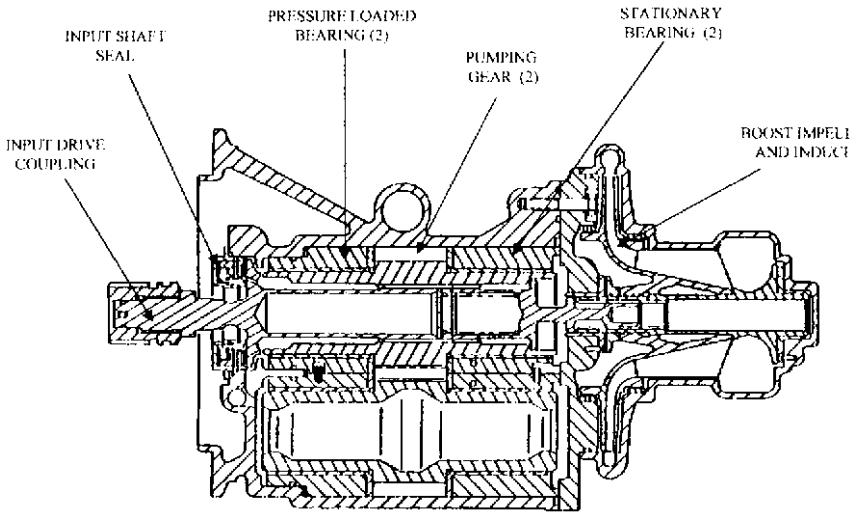


FIGURE 13 Main engine fuel pump cross section (Courtesy Hamilton Sundstrand)

pressure blow-off and pressure loading forces are closely balanced. This provides a pressure-balanced seal between the end faces of the spur gears and the bearings. This minimizes leakage over a wide range of delivery pressures on low viscosity jet fuels. The overall arrangement provides the necessary flexibility to maintain the minimum possible leakage clearances between the discharge and inlet over the complete range of operating conditions for many thousands of hours of operating life. The inherent flexibility of the design provides it with the unique capability of automatically compensating for the differing rates of thermal expansion of the materials used in the construction of the pump and the wear that will inevitably occur in usage.

The gears are manufactured from highly alloyed tool steels and surface hardened to resist wear in the harsh environment of low viscosity and low lubricity aircraft gas turbine fuels. The gear profile, lead error, and tooth spacing are held to very low limits. The roundness of the gear journals is also held to a very close limit and a mirror-like finish is applied. These journal dimensional characteristics are required because of the very low film thickness (6 to 30 micro inches or 0.15 to 0.76 microns) encountered. This is attributed to the low viscosity of hot aircraft gas turbine fuel (1 to .5 centipoise). The bearing surfaces, radial and thrust, are a highly leaded bearing bronze alloy generally with a solid film lubricant coating to assist in the initial "bedding" in.

The bearings are designed to provide full film lubrication for all operating conditions with the exception of the starting condition. On some pumps, a hybrid bearing design that incorporates a high-pressure pad to augment the bearings load carrying capacity is used. The bearing thrust faces contain gear trapping relief cuts that control the gear mesh flow dynamics. This includes avoiding any fluid trapping conditions, controlling gear stage inlet and discharge pressure pulsations. Figure 15 is a photograph of a gear set with two of the bearings.

The design of the centrifugal boost stage is quite similar to that used for the airframe boost elements. The inlet must be sized to handle the total inlet flow rate consisting of the vapor phase and the liquid phase. The use of axial inducers has become common on all sizes of pumps because of the severity of the required inlet conditions. The selected overall pressure rise of the boost stage is primarily dependent upon the temperature and, therefore, vapor pressure of the fuel at the entrance to the high-pressure element and the various pressure losses between the boost stage discharge and the high-pressure element



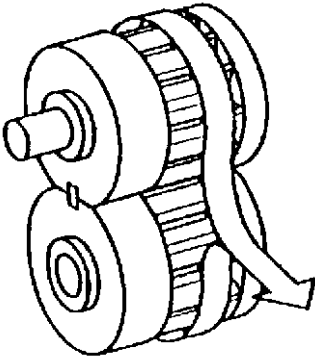


FIGURE 14 Pressure-loaded spur gear pump



FIGURE 15 Spur gear pump gears and bearings (Courtesy Hamilton Sundstrand)

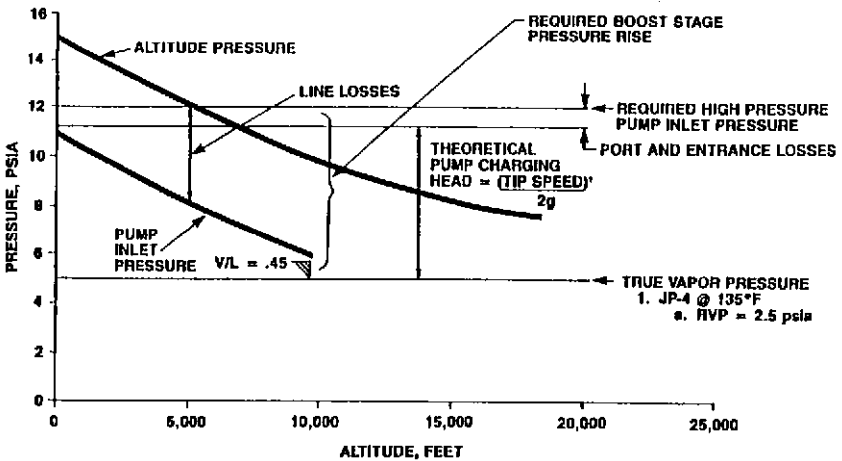


FIGURE 16 Typical pump inlet pressure stack (bar = 0.06895 × psi; °C = (°F – 32) × 0.556; m = ft × 0.3048)

inlet. These pressure losses include filter pressure losses (clean filter and clogged filter), oil-to-fuel cooler pressure losses, and various coring and plumbing pressure losses. A pressure “stack” analysis between the boost stage inlet condition and the gear stage inlet pressure requirement must be made for all operating conditions across the pump input speed range—including the emergency conditions—to determine which operating condition is the critical sizing point for the pressure rise of the pump boost stage. A simplified example of a pump pressure stack is presented by Figure 16. Reference 5 discusses boost impeller sizing. Figure 17 is a photograph of various impellers and inducers that have been used in airframe and engine fuel pumps. The specific speeds in units of feet of fluid, gpm, and rpm range from 500 to 6000 (universal specific speed  $\Omega_s = 0.18$  to 2.2) and suction-specific speeds in the same units range up to 40,000 (14.6).



**FIGURE 17** Various impellers and inducers (Courtesy Hamilton Sundstrand)

With respect to boost stages, particular attention must be paid to minimize the conduction of heat from the hot high-pressure stage to the relatively cool boost stage. This is required to avoid the possibility of vapor lock through fuel “boiling” in low-pressure regions of the boost stage under conditions of low fuel burn flow rates and, therefore, low boost stage through flow rates. These conditions generally occur at engine idle and descent operating conditions.

The pump-splined drive couplings are key to the reliability and safety criteria of the pump. Similar to the pump gears, the splined couplings are fabricated from high alloy steels with a surface hardening treatment. The design of the involute splines in terms of profile wear must take into account the lubricant used for the splines and the misalignment imposed by the various drive line elements. A spline design that will satisfy the wear conditions at rated speed will generally meet all overload conditions, including the maximum shaft shear torque requirements. Spline lubricants that have been successfully used include engine oil, fuel, and specially blended greases. Specific spline design parameters must be applied for each lubricant.

### **PERFORMANCE CRITERIA OF ENGINE MAIN FUEL PUMPS**

The key performance criterion for the high-pressure positive displacement stage of a main fuel pump is to be capable of delivering the volumetric fuel flow rate required by the engine for all operating conditions. Before it is released for flight usage, the test sequence with which the positive displacement stage must successfully comply is primarily directed at evaluating the durability of the stage under the most extreme conditions it is expected to encounter in service. There are success criteria for these tests. At the completion of each individual test, the stage must meet its specified volumetric flow service limits. Upon completion of all the tests, the unit is subjected to a teardown inspection and the component parts must not exhibit any unusual wear or distress and must be in a condition that is deemed acceptable for continued service.

The key performance criterion of the boost stage is to provide adequate pressure to the inlet of the gear stage to suppress fuel vaporization and cavitation for all operating conditions; that is, with assistance from the airframe boost pumps and the emergency conditions without assistance from the airframe boost pumps. The tests that confirm this

capability are run in conjunction with the positive displacement stage and are subject to similar success criteria. The performance criteria that specifically determine the design of the boost and high-pressure main fuel pump are presented in the following discussions.

**GEAR STAGE VOLUMETRIC PERFORMANCE**

The engine fuel flow requirements are specified in mass units. These must be converted to volumetric flow units for the lowest density fuel specified for all operating conditions. For these volumetric flow rates, the displacement required for each operating condition is determined by applying factors for pump volumetric efficiency that encompass the temperature of the fuel, production variance, and the service life flow deterioration. When the critical displacement sizing operating condition has been established, the overall volumetric performance of the pump can be defined for the complete input speed and pressure rise operating range including the required input power. Figure 18 presents the overall performance characteristic of a pressure-loaded external spur gear high-pressure stage of an aircraft engine main fuel pump.

**GEAR STAGE CYCLIC DURABILITY**

The ability of the pump to accept the cyclic duty imposed by modern engines without distress has been an accurate predictor of the pump's capability of meeting its service life requirement. The test is based upon the real-time pressure, temperature, and speed transients for engine operating conditions such as starting, ground idle, takeoff and climb, cruise, descent, and thrust reverse.

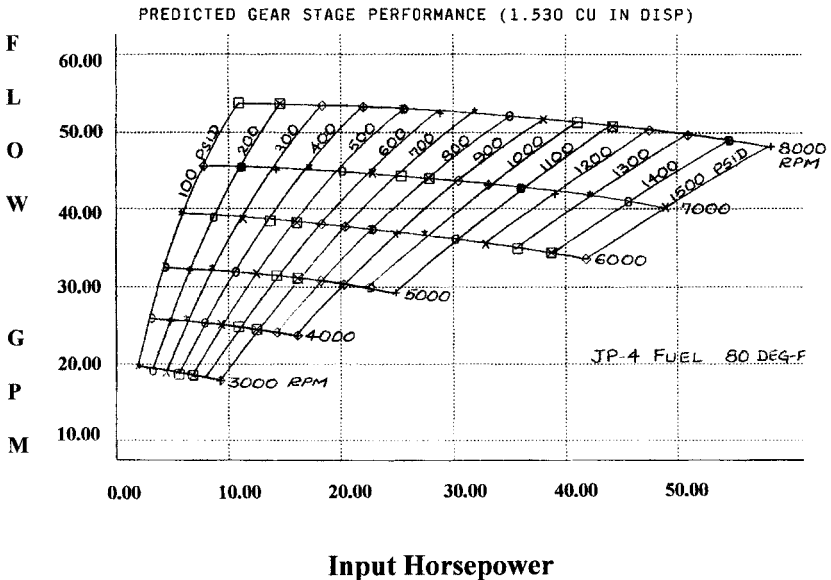


FIGURE 18 Gear stage performance ( $m^3/h = 0.227 \times \text{gpm}$ ;  $kW = 0.7457 \times \text{hp}$ ;  $\text{bar} = 0.06895 \times \text{psi}$ ;  $\text{liter} = 0.0164 \times \text{in}^3$ ;  $^\circ\text{C} = (^\circ\text{F} - 32) \times 0.556$ )

The worst cases for the sequencing of the transients are selected to achieve the highest levels of stress in the gear and bearing system. The real transient times are halved and the steady state operating times minimized to accelerate the test. The number of test cycles and overall test time are based upon the expected service life of the pump.

### **LOW LUBRICITY FUEL**

---

The use of the pumped fuel as the lubricant for the pump and all components within the fuel system is an established and required practice. Unfortunately, there is no requirement for lubricity in the fuel specifications. Therefore, some knowledge of the minimum lubricity to be expected in the field is necessary. The key factor to determine is the lubricity of the fuel under boundary lubricating conditions for evaluating the wear characteristics of the gear tooth profiles and the fuel lubricated spline teeth. An intensive cooperative industry and government evaluation effort has identified the Exxon ball and cylinder wear test machine as an accurate and reliable method of evaluating the lubricity characteristic of aircraft gas turbine fuels. The pump specification will contain the fuel lubricity level with which the pump will be required to demonstrate operation for its intended service. The pump designer must select gear materials and geometries that are compatible with the specified lubricity level and operating conditions. Wear experienced on low-lubricity fuel is a threshold type of surface failure. Therefore, this threshold limit must be avoided for all operating conditions. The test for compliance with this requirement is usually operation at take-off and cruise conditions on the specified fluid at controlled lubricity conditions. The fluid lubricity level is checked periodically to ensure compliance is met. See Reference 6 for a detailed description of the test procedure.

### **COLD STARTS**

---

Cold start tests demonstrate the capability of the pump to provide the performance necessary to start the engine under the most severe cold conditions expected and to demonstrate that the fits and clearances in the pump are compatible with the low temperatures. The cold start requirement ranges from  $-40^{\circ}\text{F}$  ( $-40^{\circ}\text{C}$ ) to  $-65^{\circ}\text{F}$  ( $-53.9^{\circ}\text{C}$ ), depending upon the fuel used and service expected.

### **CONTAMINATED FUEL**

---

The large amount of fuel an engine burns in operation and the widely varying service conditions worldwide virtually ensures that some contaminants will be introduced into the engine's fuel system. In addition to these operational contaminants, there will be built-in contaminants because of the complexity of the airframe and engine fuel system that will be experienced in the initial operation of the pumps. Tests are specified that define operation of the pump at various operating conditions on fuel containing both liquid and solid contaminants. These included salt water, quartz crystals, sand, and iron oxide ranging in particle sizes from 1500 microns to less than 5 microns. These tests are more severe for military applications than commercial applications. Military applications usually require the contamination to be metered into the inlet of the pump in relation to the fuel flow rate and then removed from the system downstream of the pump by a filtration system. Hence, the contaminant is passed through the pump in a continuous single pass manner. In all modern fuel systems, the high-pressure positive displacement stage is protected by the engine-mounted fuel filter element. The low-pressure boost stage is not protected by the engine-mounted filter element. Although the centrifugal boost stage is inherently capable of operating on the specified contaminant, special design features are employed to minimize the abrasive wear effects of swirling contaminated fuel.

## V/L CAPABILITY

---

The reason for the need of the boost stage of an engine main fuel pump to have a V/L capability and some detail of the design requirements has been presented in previous discussions. The test set-up used for V/L testing is similar to the example shown in Figure 7. The testing is usually accomplished in two parts. Both parts are run with the maximum fuel RVP expected in service. The first part is to evaluate the V/L performance of the pump at all of the specified emergency conditions and prove all conditions can be met. The second part is an endurance test at high V/L conditions to ensure that no excessive cavitation erosion damage occurs that could limit the performance or life of the pump.

## MINIMUM INLET PRESSURE

---

As long as the main fuel pump is being assisted by the airframe boost pumps, it must meet a minimum inlet pressure requirement. This inlet pressure is 5 lb/in<sup>2</sup> (0.345 bar) above the true vapor pressure (TVP) of the fuel. At this condition, the main fuel pump is required to supply the required engine fuel flow for all operating conditions. The design procedure and details for meeting this requirement were previously discussed.

The test set-up is arranged to ensure that vapor-free fuel is provided to the inlet of the fuel pump at 5 lb/in<sup>2</sup> (.345 bar) above TVP for all operating conditions. Heat exchangers are introduced into the system as required to establish the required boost and gear stage inlet temperatures. The full range of hot operating conditions, including the critical altitude idle conditions, are run to ensure vapor lock conditions do not occur. The maximum fuel RVP expected in service is used.

## REFERENCES

---

1. "Aviation Fuel Properties." Coordinating Research Council, Society of Automotive Engineers SAE.
2. "Aircraft Fuel System Vapor-Liquid Ratio Parameter." Aerospace Information Report AIR1326, Society of Automotive Engineers SAE.
3. Baker, O. "Simultaneous Flow of Oil and Gas." *The Oil and Gas Journal*, July, 1954.
4. Greenberg, C. "Flight Testing with Hot JP-4 Fuel." *American Helicopter Society*. Preprint No. RWP-11, 1982.
5. Rohatgi, V. "Sizing of an Aircraft Fuel Pump." *Transactions of the ASME*, Vol. 117, June 1995.
6. "Aircraft and Aircraft Engine Fuel Pump Low Lubricity Fluid Endurance Test." *Aerospace Recommended Practice ARP 1797*, Society of Automotive Engineers SAE.

# 9.19.2 LIQUID ROCKET PROPELLANT PUMPS

PAUL COOPER  
RAYMOND B. FURST  
ADIEL GUINZBURG

Liquid-fueled rocket engines have been used on all the major launch vehicles, including the large, first-stage booster rockets as well as the upper stages of those same vehicles, and various smaller vehicles such as the lunar lander. The propellant pumps are major components of the engine. They pump a) the oxidizer, usually liquid oxygen, and b) the fuel, which is usually liquid hydrogen, up to the high pressures needed to feed the combustion processes. In the past, a widely used fuel was kerosene in a rocket propellant formulation specified as “RP1.”

Of necessity, the pumps for these engines must have the minimum possible size and weight. They therefore run at extremely high speeds. Most have inducers or are fed by inducer pumps. These inducers have extremely high suction-specific-speed capability,  $N_{ss}$  exceeding 35,400 ( $\Omega_{ss} = 13$ ) and being as high as 70,000 ( $\Omega_{ss} = 26$ ) in liquid hydrogen<sup>1</sup>. This is so because the hydrogen is nearer its thermodynamic critical point and so generates less vapor volume when it cavitates than do other propellants. (See the discussion under “NPSH-Effects” in Section 2.1. All symbols in this subsection are defined in the nomenclature of that Section 2.1.) The main engine propellant pumps have higher heads per stage than any other centrifugal pumps in existence. As such, they are the world’s highest-energy pumps, as indicated in Figure 32 and Table 13 of Section 2.1. Whereas the high-energy pump portion of that section is devoted largely to the challenges of designing such machines for long life—say 40,000 hours or more—the life of a rocket engine pump is measured in minutes; or, in the case of reusable rockets, not much more than a few hours. For good materials choices, such a short operating life means that these pumps are unlikely to suffer failure from cavitation erosion or other wear-related phenomena, despite the high inlet tip speeds of the inducers and impellers. Extreme attention to details of the mechanical design is required in order for these pumps to survive at design conditions—near which they generally operate. A few examples of rocket propellant pumps are given in this subsection, but many others also exist in various configurations<sup>1,2</sup>.

## THE SATURN V BOOSTER ROCKET ENGINES

The Saturn V booster rocket was used in the Apollo program of the 1960s and '70s, which landed men on the moon. This rocket had a vertical height of more than 350 ft (197 m) at launch. The first or lowest stage was the largest and was propelled by five F-1 engines, each producing 1.5 million pounds (6.7 million N) of thrust. Propellants were liquid oxygen and RP1. Each engine was topped by a turbopump assembly that included both pumps on the same shaft and driven by the same hot-gas turbine. A cross-section of this assembly is shown in Figure 1, the two pumps being arranged in a back-to-back configuration and each having an inducer. The RP1 pump is the one next to the turbine, there being a considerably lower temperature difference between RP1 and the hot gas flowing through the turbine from the combustor than there would be for liquid oxygen. At the design speed of 5,490 rpm, the two pumps together consumed 52,700 hp (39 MW)—and considerably more at overspeed (approximately 6000 rpm). Table 13 of Section 2.1 contains performance figures. Essentially the same data are presented in the following descriptions of the pumps, which are summarized in Table 1. The table has been developed from various sources, including the references cited at the end of this section, as well as information supplied by the Boeing Company.

- *The oxygen pump* took in the liquid axially through a 15.75-in (400-mm) diameter inducer at the opposite end of the assembly from the turbine, as seen in Figure 1. Designed for a suction-specific speed  $N_{ss}$  of 35,400 ( $\Omega_{ss} = 13$ ) meant that when ingesting 25,080 gpm (1.58 m<sup>3</sup>/s) this machine could operate at an inlet static pressure of 22 lb/in<sup>2</sup> (0.15 MPa) above the vapor pressure  $p_v$  of the liquid oxygen. Because this liquid is cryogenic,  $p_v$  equals the pressure inside the fuel tank of the first stage of the rocket, which was not much above atmospheric pressure. Actually, the g-force and head of liquid in the tankage above the pump combined to provide additional available *NPSH*. This pump, which was designed for a specific speed  $N_s$  of about 2,100 ( $\Omega_s = 0.77$ ), consumed

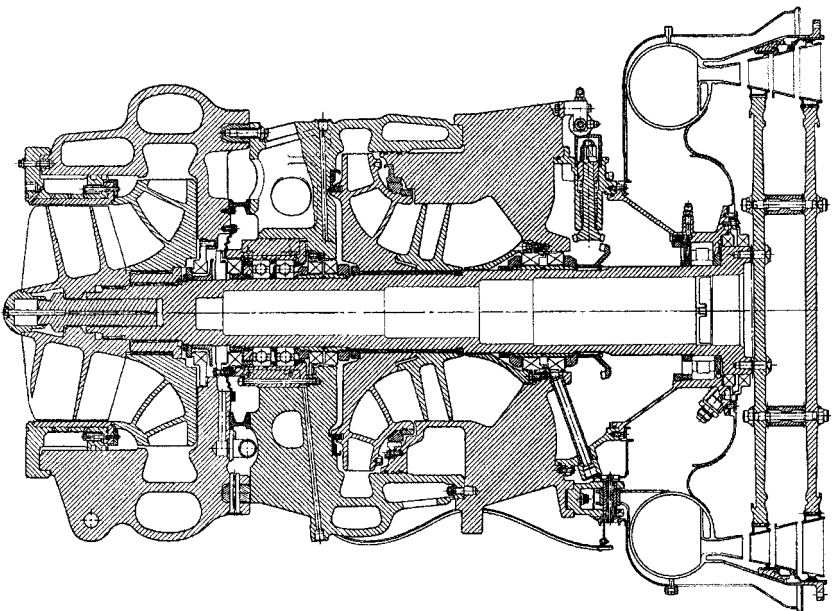


FIGURE 1 F-1 Turbopump assembly, used on Saturn V first stage rocket engine (Courtesy of The Boeing Company)

TABLE 1 Data on liquid rocket propellant pumps\*

Parameter	Units	F1 Engine		Space Shuttle Main Engine			
		Oxygen pump	RP1 pump	Oxygen pumps		Hydrogen pumps	
				LPOTP	HPOTP	LPFTP	HPFTP
Shaft power	hp (MW)	30,000 (22.4)	22,700 (19.9)	1,740 (1.3)	27,770 (20.7)	2,900 (2.2)	77,000 (57.4)
Rotative speed	rpm	5,490	5,490	5,450	31,100	15,700	37,400
Mass flow rate	lb/s (kg/s)	3,977 (1,804)	1,762 (799)	964 (437)	1,148 521	161 (73)	161 (73)
Inlet volume flow rate	gpm (m <sup>3</sup> /s)	25,080 (1.58)	15,640 (0.99)	6,080 (0.38)	7,240 (0.46)	16,300 (1.03)	16,300 (1.03)
Pressure rise	Lb/in <sup>2</sup> (MPa)	1,530 (10.5)	1,810 (12.5)	332 (2.3)	4800** (33.1)	222 (1.5)	6,840 (47.2)
Head rise (approx.)	ft (m)	3,100 (945)	5,100 (1,555)	670 (204)	9,700 (2,960)	7,240 (2,200)	200,000 (61,000)
Specific speed (stage)	rpm,gpm,ft (universal)	2,095 (0.77)	1,130 (0.41)	3,230 (1.18)	2,700 (0.99)	2,550 (0.93)	1,150 (0.42)
Inducer diameter	in (mm)	15.75 (400)	16.00 (406)	11.725 (298)	4.7 (119)	12.014 (305)	
Impeller exit diameter	in (mm)	19.50 (495)	22.95 (583)		6.80 (173)		12.00 (305)
Overall diameter x length	in x in (mm x mm)	44 x 60 (1,118 x 1,524)		18 x 18 (457 x 457)	24 x 36 (610 x 914)	18 x 24 (457 x 610)	22 x 44 (559 x 1,118)
Turbopump weight	lb (kg)	3,080 1,397		276 (125)	622 (282)	177 (80)	775 (352)

\*Compiled from information supplied by The Boeing Company and References 1-5.

\*\*Main stage. Small preburner stage pumps 117 lb/sec (53 kg/s) to approximately 3300 psi (23 MPa) above main stage discharge.

30,000 hp (22 MW) or 57 percent of the total turbine shaft power, and it generated over 1,500 lb/in<sup>2</sup> (10 MPa) of pressure rise.

- *The fuel (RP1) pump*, being in the middle of the turbopump assembly, had to take in the 15,640 gpm (0.99 m<sup>3</sup>/s) of RP1 through a side inlet piping configuration, which generally results in less  $N_{ss}$ -capability than axial inlet piping. Here the inducer is larger and the flow rate lower than for the liquid oxygen pump, creating the potential for higher  $N_{ss}$ ; yet it ended up being lower, namely  $N_{ss} = 34,200$  ( $\Omega_{ss} = 12.5$ ). Nonetheless, this enabled the RP1 pump to operate at a static inlet pressure as low as 16 lb/in<sup>2</sup> (0.11 MPa) above the (negligible) vapor pressure of this liquid. With specific speed  $N_s$  just over 1,100 (0.40), this pump consumed the remaining turbine shaft power of 22,700 hp (17 MW) and generated a pressure rise of just over 1,800 lb/in<sup>2</sup> (12.4 MPa).
- Throughout the burn, these pumps deviated no more than about 8 percent from the design value of  $Q/N$ ; that is, the flow coefficient was essentially constant. Thus, this turbopump



did not suffer from the off-design low-flow conditions of most commercial, industrial pumps, as described in Section 2.1 and Subsection 2.3.2, including those of high energy level, which made it a little easier for this machine to operate at high energy levels.

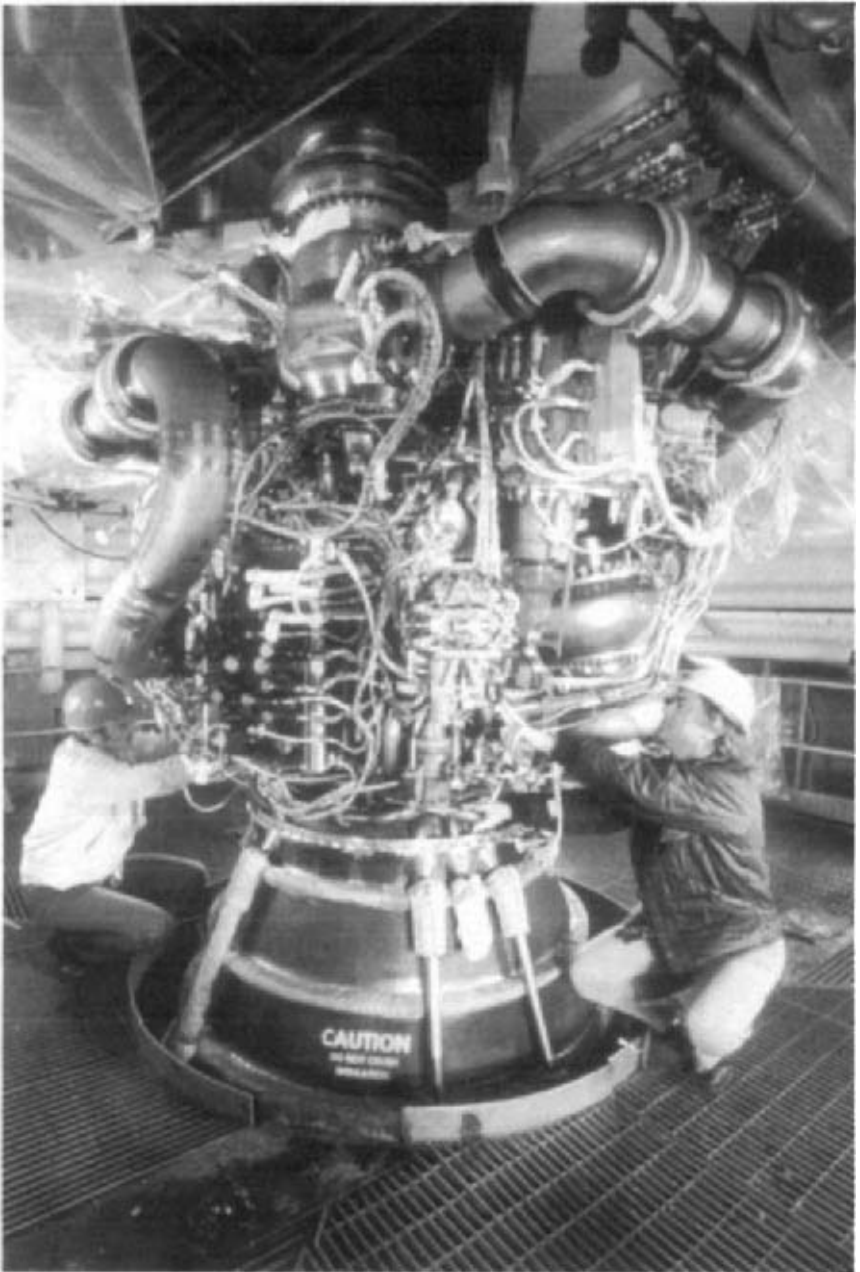
## THE SPACE SHUTTLE MAIN ENGINES

The space shuttle program, which began in the 1970s, dealt with a launch vehicle that was flanked by two large solid-fueled rockets. In the middle at the base were three liquid-fueled “main” engines, each having nearly 500,000 lb (2.2 million N) thrust and propelled by hydrogen fuel and oxygen at a mixture mass ratio of 6:1 (oxygen to hydrogen). Each of these space shuttle main engines (SSME’s) has a dedicated pumping system, consisting of a low-pressure single-stage inducer-type pump for each propellant, which in turn feeds a high pressure pump. Three of these four pumps can be seen in the photograph of the engine in Figure 2. Located up above is the low-pressure hydrogen pump, with its large discharge line going off to the right and down to the high-pressure hydrogen pump below. Opposite, on the left, is the high-pressure oxygen pump, with its large inlet line also in view. Engineering of these high-pressure propellant pumps embodied a triple challenge in comparison to the F-1 pumps, because a) this engine was designed to be re-used, so the pumps had to have a life of 7.5 hours with 100 starts; b) the pumps for this engine have higher energy levels than the F-1 pumps, and, c) due to the mission profile, they have to be throttled back further from the design point. Each of these pumps is boosted by a low-pressure inducer-type pump to suppress cavitation enough to maintain performance<sup>3</sup>.

The propellant flow system is illustrated in the schematic diagram of Figure 3. (The pump speeds, pressures, and flow rates shown in this figure are somewhat lower than the design conditions of Table 1, which for the SSME pertains to the maximum engine thrust level.) All four of the pumps are driven by turbines and so are called “turbopumps.” The system picks itself up by its own bootstraps, so to speak; each low-pressure turbopump boosts the flow to the corresponding high-pressure pump and is driven by the same fluid that it pumps. This driving fluid comes back from each high-pressure pump, the low-pressure oxygen turbopump (LPOTP) being driven by recirculated liquid oxygen, and the low-pressure hydrogen or fuel turbopump (LPFTP) turbine being fed by gaseous hydrogen heated by the thrust chamber, as indicated in Figure 3.

The high-pressure pumps are driven by turbines fed by “preburners,” which are combustors that burn hydrogen-rich. Some of the fuel entering these combustors is the gaseous hydrogen coming from the LPFTP turbine exhaust, which cools the turbine housings on the way to the preburners. But most of the fuel supplied to the preburners is the 80 percent of the liquid hydrogen discharging from the high-pressure fuel turbopump (HPFTP), which first flows through the cooling passages of the nozzle walls. [Eleven percent of the oxygen is also fed to the preburners by way of the preburner boost stage that is a part of the high-pressure oxygen turbopump (HPOTP) package. Finally, the partially burned fuel passes as a hot gas into the main combustion chamber, where more oxygen is added and the pressure is 3,000 lb/in<sup>2</sup> absolute (21 MPa)<sup>3,4</sup>.] Most of the remaining 20 percent of the hydrogen is that which was already described as cooling the main combustion chamber and, along the way, becomes gaseous and powers the drive turbine of the LPFTP. It also cools the hot-gas manifold and injector and pressurizes (in a small amount) the fuel tank. Approximately 75 percent of the liquid from the high-pressure oxygen turbopump (HPOTP) goes directly to the main combustion chamber, 11 percent to the preburners (as already stated), about 13 percent to drive the turbine of the low-pressure oxygen turbopump (LPOTP), and a small amount is sent to pressurize the tank.<sup>5</sup> A brief description of each pump follows:

- *The low-pressure oxygen turbopump (LPOTP) consumes 1,740 hp (1.30 MW) and runs at 5,450 rpm. It has a single-stage, axial-flow, inducer-type impeller that is 11.725 in (298 mm) in diameter and is driven by a six-stage liquid-oxygen hydraulic turbine. Pump head rise is 670 ft (204 m) so the HPOTP therefore operates without pressure*



**FIGURE 2** The space shuttle main engine (SSME) (National Geographic Magazine, March 1981: Jon Schneeberger/NGS Image Collection)

# SSME PROPELLANT FLOW SCHEMATIC

(RPL/MR 6.0)

FMOF

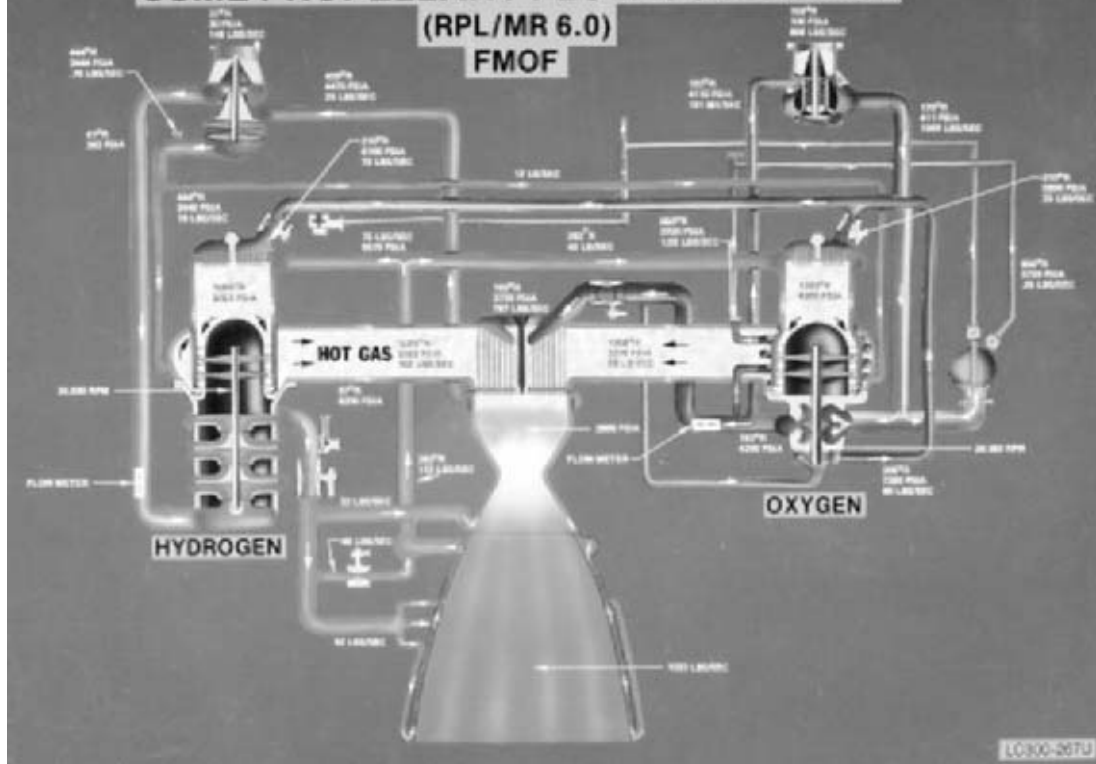


FIGURE 3 SSME liquid oxygen and hydrogen pumping arrangement (Courtesy of The Boeing company)

loss due to cavitation at all engine conditions. Specific speed  $N_s = 3,230$  (1.18), which is low for an inducer, but this one performs a more substantial pumping task than do inducers running at high speeds on the same shaft as the high-pressure centrifugal stages they feed. The shaft has two ball bearings cooled by liquid oxygen, and the envelope of the package is 18 in (457 mm) in diameter  $\times$  18 in (457 mm) long.

- *The low-pressure fuel turbopump (LPFTP)* is similar in concept to the LPOTP. It is a 2,900 hp (2.2 MW) machine that runs at 15,700 rpm. The inducer-type impeller is 12.014 in (305 mm) in diameter and is driven by a two-stage gaseous-hydrogen turbine. It ingests liquid hydrogen to the extent of  $\frac{1}{6}$  of the mass flow rate of oxygen. Due to the very low specific gravity of liquid hydrogen ( $= 0.0708$  at atmospheric pressure), the head rise is more than 7,000 ft (2,100 m).  $N_s = 2,550$  ( $\Omega_s = 0.93$ ). The shaft has three ball bearings cooled by liquid hydrogen, and three seals limit leakage between the pump and the turbine before engine start and during operation.
- Both low-pressure pumps exhibited suction-specific speeds  $N_{ss}$  in excess of 35,000 ( $\Omega_{ss} = 13$ )<sup>4</sup>. They are shown schematically at the top of Figure 3, and the high-pressure pumps are below them.
- *The high-pressure oxygen turbopump (HPOTP)* is shown in cross-section in Figure 4 together with the associated preburner unit. Inducers are shown in the detailed cross-sectional drawing of Figure 5 feeding the double-suction main stage that generates nearly 5,000 lb/in<sup>2</sup> (34 MPa)—making this one of the world's highest-energy pumps (as defined in Section 2.1, Figure 32). And more than 3,000 lb/in<sup>2</sup> (21 MPa) in addition to this pressure is generated in the small booster impeller (on the outer end of the turbopump as seen in Figures 4 and 5) that feeds about 11 percent of the main flow to the preburners for driving both high-pressure pumps. Both shrouds of the main impeller act as orificed balancing disks to keep all but a small preload off the two angular-contact ball bearings, which are cooled by liquid oxygen. Radial loads are minimized by the use of a vaned diffuser. The compact design and high speed (over 31,000 rpm) of this 28,000 hp (21 MW) machine result in operation between the first and second critical speeds. Several seals are utilized,

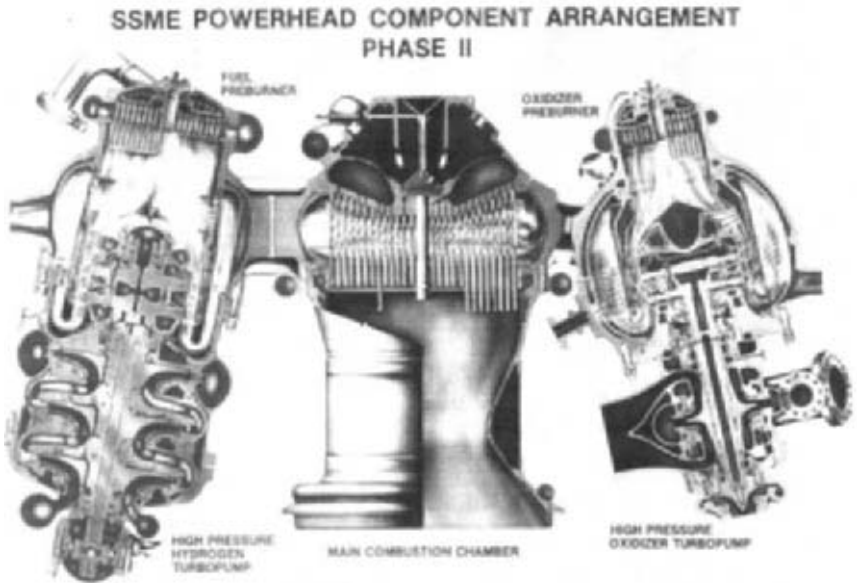


FIGURE 4 SSME high-pressure turbopumps (Courtesy of The Boeing company)

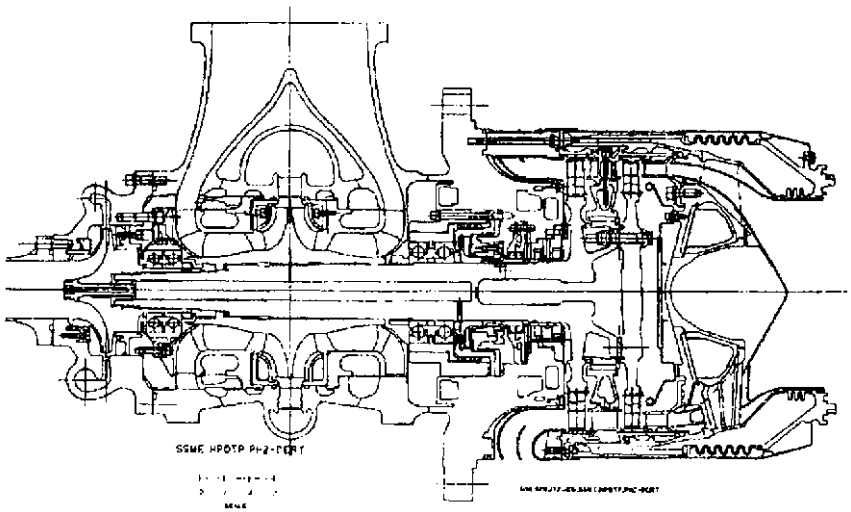


FIGURE 5 Cross-section of SSME high-pressure oxygen turbopump (Courtesy of The Boeing company)

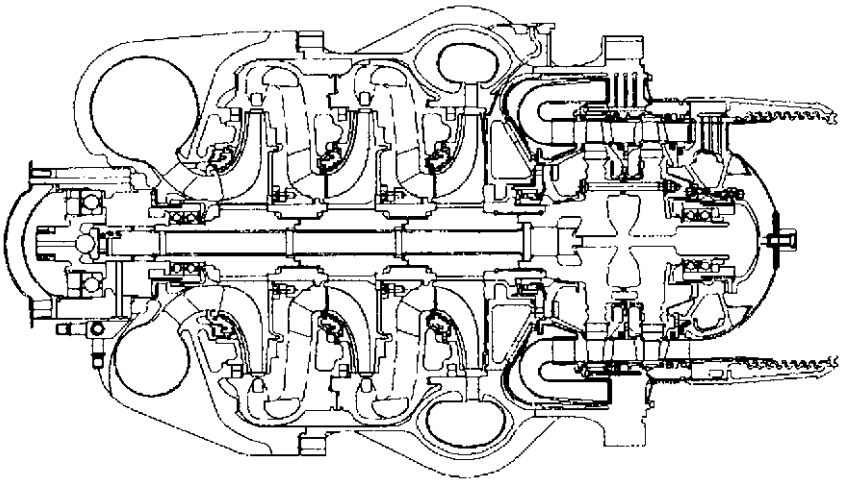


FIGURE 6 Cross-section of SSME high-pressure oxygen turbopump (Courtesy of The Boeing company)

including a helium-purged seal that isolates the hot gas of the turbine from the cold liquid oxygen. Special material combinations are used to prevent sparking, ignition and explosion due to rubbing in the strong oxidizing environment of the liquid oxygen.

- *The high-pressure fuel turbopump (HPFTP)* is also shown in Figure 4. Additional detail is afforded by the cross-sectional drawing of Figure 6. No inducer is needed due to the pressurization of the LPFTP and the more favorable vaporization characteristics of liquid hydrogen. The pump has three identical impellers and diffusers, except that the third-stage diffuser discharges into a scroll or volute, and the third-stage impeller also

acts as an orificed balancing disk, which removes all axial thrust (except for a small spring-preload force) from the angular-contact, liquid hydrogen-cooled ball bearings located at each end of the pump-and-turbine package. The head per stage is over 65,000 ft (20,000 m) because of the high pressure rise and low density of liquid hydrogen. This leads to an impeller OD tip speed of nearly 2,000 ft/sec (600 m/s)—probably the highest in existence for a pump and successfully deployed in titanium, which has the benefit of a higher strength-to-weight ratio than the more commonly used steels. The high speed (over 37,000 rpm) keeps this 77,000 hp (57 MW) machine small and light and necessitates operation between the second and third critical speed.

### THE RD-170 ENGINE

---

The RD-170 rocket engine was developed in the Soviet Union and is described in some detail by Sutton<sup>6</sup>. Propellants are liquid oxygen and an RP1 equivalent. Consisting of four nozzles, each of which produces about the same thrust as one SSME, this “four-engines-in-one” configuration is fed by a single propellant pump assembly—similar in concept to the F-1 turbopump. Referring to Table 13 of Section 2.1, the oxygen pump produces a pressure rise of about 8,500 lb/in<sup>2</sup> (59 MPa), which is undoubtedly the highest pressure rise of any centrifugal pump stage in the world, making it the highest-energy pump of Figure 32 in Section 2.1. Not far behind is the RP1 pump at 7,100 lb/in<sup>2</sup> (49 MPa). Assuming the pump efficiency to be 80 percent would yield a total shaft power for both pumps of about 230,000 hp (172 MW). At such high energy levels, as discussed in Section 2.1, the life of this pump must indeed be quite short. However, the design appears to have been successful. The only drawback is the environmental issue concerning the burning of a large quantity of hydrocarbon fuel, which is also an inhibition to further use of the F-1 engine.

### REFERENCES

---

1. “Liquid Rocket Engine Centrifugal Flow Turbopumps.” Report SP-8109 of the series entitled *NASA Space Vehicle Design Criteria (Chemical Propulsion)*. NASA, 1973.
2. “Turbopump Systems for Liquid Rocket Engines.” Report SP-8107 of the series entitled *NASA Space Vehicle Design Criteria (Chemical Propulsion)*. NASA, 1975.
3. Furst, R. B. “Space Shuttle Main Engine Turbopump Design.” Society of Automotive Engineers, Paper No. 730926, October 1973.
4. Furst, R. B. “Space Shuttle Main Engine Turbopump Design and Development.” American Institute of Aeronautics and Astronautics, Paper No. 75-1301, September 1975.
5. “Space Shuttle Technical Manual: SSME Description and Operation, Space Shuttle Main Engine.” Report E41000/RSS-8559-1-1-1, published for NASA under Contract NAS8-27980, The Boeing Company, Rocketdyne Propulsion and Power, July 1977.
6. Sutton, G. P. *Rocket Propulsion Elements*, 6th edition, Wiley, 1992.

---

# SECTION 9.20

---

# PORTABLE TRANSFER OF HAZARDOUS LIQUIDS

---

P. A. NOLTE

Transfer systems for hazardous chemicals must not only take into account the best means to transport the chemical based on the chemicals fluid characteristics, but must also pay particular attention to both safety and environmental issues. The chemical can be something as common as gasoline, or a very poisonous restricted-use pesticide such as Parquat. When the requirement of portability is added to the chemical handling system, design parameters must now take into account variables such as power source, environmental conditions, and chemical restraints. Several power sources have been incorporated through out the years for the portable transferring of hazardous chemicals. One of the earliest is simple hand power. Others consist of gasoline powered, ground-driven, compressed air, and battery operated pumping systems.

Major markets that require the portable transfer of chemicals include petroleum, agricultural, construction, pest control, and lawn care. Systems must be adaptable to changing environmental regulations, chemical container designs, and application requirements.

## **AGRICULTURAL REQUIREMENTS**

---

The need for portable chemical transfer systems in the agricultural market arises from farmers working fields with large equipment, usually several miles away from local chemical dealerships and storage facilities. It is usually more economical to bring the chemical to the piece of application equipment while it is in the field, rather than transporting the application equipment back and forth from the field. Chemical is delivered to the field in several different ways, depending on the volume required. Tanks can vary in size from 120 gallon (450 liter) herbicide tanks that can be transported by pickup trucks, to large 1000 gallon (3800 liter) tanks that are delivered by trailers or large custom trucks. With the growth of the custom applicator business, the sophisticated chemical transfer rigs have



focused on speed of transfer, flexibility to supply the chemical required, and the ability to cover large areas. Some large aerial applicator rigs have the ability to allow spray helicopters to land directly on the rig, thus allowing quick, portable, and convenient transfer of spray solution from tanks into the helicopter.

The majority of hazardous chemical transferring in the agricultural market deals with the usage of either fertilizers or pesticides. A pesticide is a group of chemicals that consist of insecticides, herbicides, or fungicides. Insecticides focus on the control of insects, herbicides are chemicals used to control of grasses and weeds, and fungicides are chemicals used to control crop damaging bacteria and/or fungus. During the last 20 years, the usage of chemicals in the agricultural market has been greatly affected by growing environmental concerns and worker safety. Environmental concerns have caused chemical formulations to use less aromatic solvents. As an alternative, many chemicals are now viscous water-based suspensions that generate pumping challenges. Chemical systems have also seen new regulations that control items such as chemical spillage from fittings, tank sizes, and design and testing parameters. This, in turn, has affected the needs and requirements of the chemical handling systems.

Fertilizers present a transferring challenge due to the large volumes that are used, and the corrosive nature of most solutions. Two types of power modes are commonly used in the market for the transferring of fertilizers: gasoline-powered centrifugal pumps and ground-driven positive displacement pumps. Gasoline-powered centrifugal pumps used are usually lightweight aluminum or plastic units with 2 in (50 mm) ports. The pumps are coupled to a 3 to 5 hp (2 to 4 kW) gasoline engine and are capable of transferring rates up to 150 gpm (568 l/min). These high flowrate gasoline powered pumps are used to transfer fertilizer and water from large 1000 to 2000 gallon (3785 to 7570 liter) transport tanks into the application equipment's on-board storage tanks, 300 to 500 gallons (1135 to 1890 liters) in size. Ground driven pumps are mounted on the implement equipment such as planters and cultivators. The pumps are used to transfer and meter the fertilizer through a network of tubing that runs to the backside of cutting blades. This allows the knifing of the fertilizer into the ground. Ground driven pumps are popular for this type of application because the volume dispensed is directly proportional to the ground speed of the implement. Popular pumps that have been adapted for ground driven applications are positive displacement piston, diaphragm or multi-tube peristaltic pumps.

Pesticide transfer is now rigorously regulated because of environmental concerns and an increased emphasis on decreasing worker exposure to the hazardous formulation of a large percentage of these chemicals. The Environmental Protection Agency (EPA) has guided the agricultural chemical industry away from using 2.5 gallon (9.5 liter) throw-away containers to larger, returnable, re-usable, chemical-specific containers. These "Mini Bulk" tanks range in size from 15 to 200 gallons (50 to 750 liters), depending on the chemical usage rate. This change in the way farm chemicals are packaged to the end user has generated new requirements for portable pumps. Current chemical delivery systems have evolved around the usage of 12-volt power systems. Due to regulator restrictions that forbid the cross contamination of agricultural chemicals, the delivery systems are usually designed for a particular chemical or container. An adequate pumping rate for most 12-volt portable system is a rate of 5 to 10 gpm (18 to 38 l/min). Agricultural chemicals come in a wide range of viscosities, varying from 1 to 500 centipoise. Some are true liquids, whereas most are a suspension or mix. Typically, positive displacement pumps of the diaphragm, piston, or gear type are used for portable chemical transferring. Gear pumps are usual limited to the low viscosity chemicals with no suspended solids. Piston and diaphragm pumps are best suited to handle the higher viscous chemicals, many of which have suspended solids. Chemicals with solids usually will require tank circulation, and this must be designed into the transfer system.

Figure 1 shows a pumping system on a 120 gallon (450 liter) tank that consists of a pump, 12-volt motor, a digital meter system, and no-drip hose coupling. The pump is permanently mounted to the shipping container at the time of tank manufacture. The motor, meter, and hose are removable items that are normally supplied by the chemical dealer. This allows the drive unit and metering device to be transferred from tank to tank, after a tank is emptied. The pump is a 6-chambered plastic diaphragm pump and is mounted to the tank by means of a bolting flange. The mounting flange also contains a built-in vent to





**FIGURE 1** Portable 12-volt chemical pump (FlowsERVE Corporation)

allow air in during fluid pumping. An internal bypass valve in the pump is connected to the inside of the chemical tank, allowing chemical circulation within the tank during bypassing. This pump also allows manual opening of the bypass valve to allow drainage of chemical from the meter and hose before removal. When the pump is mounted to the tank during shipping, the complete system must meet and pass specific Department of Transportation (DOT) tests. These tests are specified in the United States by DOT's HM181 specifications. Depending on the size of the container and the hazardousness of the chemical, these tests can require drop tests of several feet at 0°F (minus 17.8°C), vibration, stacking, and pressure tests.

Figure 2 shows a typical 120 gallon (450 liter) chemical "Mini-Bulk" tank with the pump connected to the tank by a coupler (not permanently attached). The coupler system provides a means for attaching and detaching the pump and the tank, a means for venting, and a dip tube assembly allowing suction from the bottom of the tank. The pump assembly is coupled through the tank coupling for chemical dispensing and is then removed for transporting. The pump shown is a stainless steel, 12-volt diaphragm pump, with a stainless steel flow meter. The chemical dealer fills the mini-bulk tank with chemical. The grower purchases the chemical, uses the pump to dispense chemical into an application rig, and then returns the tank empty to the dealer.

## **PETROLEUM AND CONSTRUCTION REQUIREMENTS**

---

One of the original areas requiring the use of portable pumps is the transfer of gasoline and diesel fuel. The need to refuel and maintain equipment in remote locations has generated a large need for portable transfer equipment. Road and building construction, mining, and farming all involve heavy equipment that must be refueled and maintained on a regular schedule. One of the earliest and simplest methods of portable transferring was with hand pumps. Hand pumps are positive displacement pumps of piston, vane, or diaphragm-type design. Of course, the power supply is very limited with hand pumps, and they are typically used only on thin liquids and small jobs. On large pieces of equipment,



**FIGURE 2** 120 gallon (454 l) “Mini-Bulk” Container and pump (Flowsolve Corporation)

the need is to transfer large volumes of fluids, such as water, antifreeze, diesel, gear lube, grease, and transmission fluid.

Figure 3 shows a portable maintenance vehicle with air powered piston pumps. In the construction industry, compressed air is a common power source for transferring product. A typical truck consists of a gasoline-powered air compressor, several tanks of petroleum products plus water and antifreeze. The size and type of pump will normally depend on the size of the equipment requiring servicing and the fluid being pumped. For thin fluids, such as diesel oil or gasoline, high volume, low pressure ratio pumps (approaching 1:1) will be used. Occasionally, on units that have the option of a power take-off (PTO), a high volume centrifugal-type pump will be used. For the oils and lubricants, higher pressure ratio pumps (3:1 to 5:1) are required because of higher transfer pressure requirements. To transfer grease, high pressure ratio pumps—to 20:1—are required. The pumps are normally coupled with a hose reel, 50ft (15 m) of hose, and a control nozzle.

### **LAWN AND PEST CONTROL**

Lawn and pest control companies require a portable means of transferring chemicals in order to provide treatments. Liquids are used to treat yard infestations; in addition, the majority of homes and buildings are treated for termites during construction. It is common for lawn care companies to use PTO-driven centrifugal pumps capable of delivering 10 to 15 gpm (38 to 56 l/min) through a 100 ft (30 m) hose. Specialty requirements, such as tree spraying, will require a higher pressure system, normally a gasoline-powered piston pump. For insecticide treatment, the power source is commonly either electricity or gasoline. Typical pumps are roller pumps, capable of approximately 4 gpm (15 l/min) at 50 lb/in<sup>2</sup> (3.45 bar).

These industries have taken major steps to limit chemical exposure to the general public and to their operators. Efforts have been made by many to eliminate the need of transporting large 100-plus gallon (378 liter) tanks of mixed chemicals. One method that allows



**FIGURE 3** Flatbed service truck (Aro Fluid Products)

the tanks to hold and transport only clean water is to inject the chemical into the discharge only at time of use. The chemical is kept in small, 1 to 5 gallon (3.5 to 20 liter) containers with 12-volt metering pumps attached, which allow direct injection into the clean water line. Other systems use small proportioning pumps. These units are two-stage piston pumps powered by clean water. The smaller piston injects a set volume of chemical into the water supply for each stroke of the larger water piston.

---

# SECTION 9.21

---

# WATER PRESSURE BOOSTER SYSTEMS

---

SATORU SHIKASHO

## ***TYPES OF WATER PRESSURE BOOSTER SYSTEMS***

---

Plumbing fixtures and equipment connected to a water source will function properly only when a minimum water supply pressure is consistently available. Whenever this minimum pressure cannot be maintained by the supply source, a means of boosting the water pressure should be considered.

The commonly used methods for boosting pressure are

1. Elevated gravity (tank) systems
2. Hydropneumatic tank systems
3. Variable-speed-drive centrifugal pump booster systems
4. Tankless constant-speed multiple centrifugal pump systems
5. Limited-storage, constant-speed multiple centrifugal pump systems

Table 1 identifies the significant advantages and disadvantages of each system.

Although gravity and hydropneumatic tank systems have some distinct advantages, most installations favor constant-speed multiple-pump and variable-speed-drive systems. Because gravity and hydropneumatic tank systems are now seldom specified, they will not be discussed in detail here. Multiple-pump systems are well suited for high-rise buildings, apartment buildings, schools, and commercial installations. Variable-speed-drive systems are particularly suited for industrial applications, where control precision is required and maintenance capability for complex electronic apparatus is present.

It is important to remember that the primary function of a pressure booster pump for a building, whether variable- or constant-speed, is to maintain the desired system pressure over the entire design flow range. It is also important to recognize that the cold water service piping configuration is an open-loop system, not a closed-loop system as it is in

**TABLE 1** Comparison of significant factors for pressure booster systems

System type	Advantages	Disadvantages
Elevated gravity tank	Simplicity, large storage capacity, low energy usage, reserve storage capacity for fire protection	Size and weight, water damage potential, freeze potential if roof-mounted, corrosion and contamination potential, limited pressure for floor immediately below tank, possible unsightly appearance, periodic cleaning and painting
Hydropneumatic tank	Location not critical, low energy usage, limited storage capacity, pump does not run when there is no demand, operation in optimum pump flow range	Requires compressed air source, corrosion and contamination potential, large pressure variation, relatively large, standby provision costly
Variable-speed drive: Fluid couplings	Simple controls, off-the-shelf motor, standby provision less costly than for above units	Slow response to sudden demand change, may require heat exchanger to cool drive, slip losses result in lower maximum speed and higher motor power, requires selective application, no water storage
Variable-speed drive: ac type	Low motor current inrush, precise pressure control, higher than 3600 rpm possible, few mechanical devices, large power capability at lower first cost	Complex electric circuitry, high initial cost for low-power units, may require special motors, motor low-speed limitation, rapidly changing technology, requires selective application
Tankless constant-speed multiple pump	Relatively low first cost, uses time-proven components, compact size, inherent partial standby capacity, extra standby capacity inexpensive, location not critical, good pressure regulation	Continuously running lead pump, difficult to accurately determine capacity split among pumps, no water storage, problems associated with low flow rates
Limited-storage constant-speed multiple pump	Shuts down during very low water demand, uses time-proven components, standby capacity inexpensive, location not critical, limited water storage, no air-to-water contamination with diaphragm tank	No significant disadvantages, tanks with high maximum working pressure may be difficult to obtain

heating and cooling systems. With an open-loop system, the static head above the pump is not canceled by the down leg of the piping, and therefore the pump must develop a head equal to or greater than the static head, even at zero flow (with suction pressure at design). Review Sections 8.1 and 8.2 for further discussions on closed-loop systems.

**Variable-Speed-Drive Pressure Booster Systems** Initial variable-speed drives were fluid couplings, magnetic couplings, and liquid rheostat (wound rotor motor) drives. The coupling-type drives were driven by a constant-speed motor, with the coupling output shaft varying in speed. With the advent of solid-state electronics technology and circuit miniaturization, most variable-speed drives currently used for pressure booster applications are of the solid-state, ac, adjustable-speed type. These drives are discussed in Subsection 6.2.2.

Variable-speed drives are usually specified for their low operating cost potential. To achieve the energy-savings goal, the system conditions should cause the drive speed to vary between 50 and 75% of full speed during most of the operating period.

The pump speed, head, and flow relationships are expressed by the affinity laws:

- Flow varies directly as speed:

$$\frac{Q_2}{Q_1} = \frac{N_2}{N_1} \quad (1)$$

- Head varies directly as the square of the speed:

$$\frac{H_2}{H_1} = \left(\frac{N_2}{N_1}\right)^2 \quad (2)$$

where  $Q$  = flow rate, gpm ( $\text{m}^3/\text{h}$ )

$N$  = pump speed, rpm

$H$  = pump total head, ft (m)

The required pump total head at design conditions is

$$H = (H_d - H_s) + H_f \quad (3)$$

where  $H$  = required pump total head at design conditions, ft (m)

$H_d$  = design system pressure at point of control, ft (m)

$H_s$  = minimum design suction pressure, ft (m)

$H_f$  = sum of all losses between  $H_d$  and  $H_s$  at design flow, ft (m)

At flow rates less than design conditions and suction pressures higher than the minimum design pressure, the pump head requirement is reduced by the change in pipe frictional losses  $H_f$  and the additional suction pressure  $H_s$  available. Also, because of the rising characteristic of the centrifugal pump performance curve as the flow decreases, an excess head is developed by the pump. All of these changes will alter the required pump total head and the pump speed from the design (maximum) values.

For a single operating pump unit, design maximum speed will be required at design minimum suction head and design maximum flow. Minimum speed will be required at maximum suction head and minimum flow. The procedure required to determine the speed range of the pump driver requires construction of the system-head curve, the pump head-capacity curve (see Section 8.1), and the affinity curve. Rearranging the affinity equations (Eqs. 1 and 2), the speed changes are calculated:

$$N_2 = N_1 \left(\frac{Q_2}{Q_1}\right) \quad (4)$$

$$N_2 = N_1 \left(\frac{H_2}{H_1}\right)^{1/2} \quad (5)$$

where the subscripts 1 and 2 represent the higher and lower speed values, respectively, for pump conditions at the same specific speed (see Subsection 2.3.1) or along the same affinity line.

The following examples illustrate how changes in flow rate, pipe frictional losses, and suction head affect pump speed.

EXAMPLE 1 With no change in suction pressure—first (design) conditions:

$$H_d = 193 \text{ ft (58.8 m)}$$

$$H_s = 50 \text{ ft (15.2 m)}$$

$$H_f = 7 \text{ ft (2.1 m)}$$

$$Q = 190 \text{ gpm (43.1 m}^3\text{/h)}$$

$$N = 3500 \text{ rpm}$$

$$H = (193 - 50) + 7 = 150 \text{ ft (45.7 m) (Eq. 3)}$$

Second conditions:

$$H_d = 193 \text{ ft (58.8 m)}$$

$$H_s = 50 \text{ ft (15.2 m)}$$

$$H_f = 1.9 \text{ ft (0.58 m)}$$

$$Q = 100 \text{ gpm (22.7 m}^3\text{/h)}$$

$$N = \text{to be calculated}$$

$$H = (193 - 50) + 1.9 = 144.9 \text{ ft (44.18 m) (Eq. 3)}$$

The 3500-rpm pump head-capacity curve, the system-head curves, and the affinity (square) curves are shown in Figure 1. The operating points are lettered. Point A is for maximum flow at minimum suction head (design conditions). Point B is for lower flow at minimum suction head at a speed to be determined. The reduced piping losses between head points  $H_d$  and  $H_s$  are represented by the system-head curves.

To determine the approximate speed at point B, it is necessary to use trial and error because the flow and head ratios in Eqs. 4 and 5 are not known. The following procedure may be used to estimate the speed (Figure 1):

1. Draw an affinity (square) curve passing through the zero-flow/zero-head point and the lower operating point (point B) and intersecting at head-capacity curve of known speed (point C).

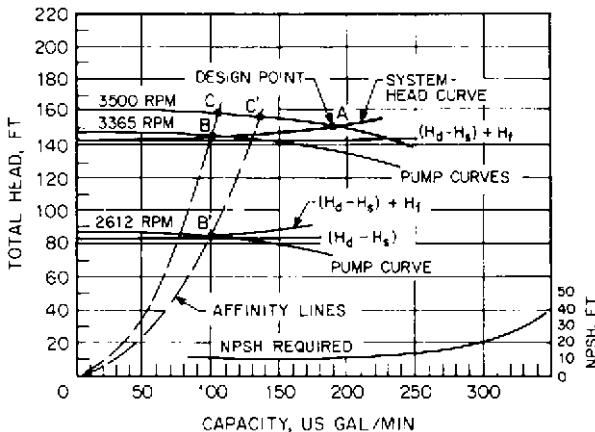


FIGURE 1 System and pump curves to determine speed reduction for the 2-in (51-mm) pump in Examples 1 and 2. (ft  $\times$  0.3048 m; gpm  $\times$  0.2271 = m<sup>3</sup>/h)

2. Read the probable flow rate at point *C*, the point of intersection between the affinity curve and the pump curve of known speed.
3. Calculate the head relative to the flow rate read at point *C*, based on the square curve relationship:

$$H_1 = \frac{H_2}{\left(\frac{N_2}{N_1}\right)^2} \quad (6)$$

where subscripts 1 and 2 represent the values at the 3500-rpm and lower speeds (points *C* & *B*), respectively.

4. Compare the head calculated in step 3 with the head of the pump curve (point *C*) of known speed at the probable flow rate of step 2. If the values differ significantly, try another flow rate and repeat steps 3 and 4.
5. Using the accepted head from step 4, calculate the speed at the operating point (point *B*) using Eq. 4 or 5. The equation not used may then be used for verification.

For this example, the estimated flow rate at point *A* (step 2) is 104 gpm (23.6 m<sup>3</sup>/h) and the calculated head at the same point (steps 3 and 4) is

$$H_1 = \frac{144.9}{\left(\frac{100}{104}\right)^2} = 156.7 \text{ ft} \quad \text{or} \quad \frac{44.18}{\left(\frac{22.7}{23.6}\right)^2} = 47.76 \text{ m}$$

The speed at the operating point (point *B*) is

$$N_2 = 3500 \left(\frac{100}{104}\right) \quad \text{or} \quad 3500 \left(\frac{22.7}{23.6}\right) = 3365 \text{ rpm} \quad (\text{Eq. 4})$$

Check:

$$N_2 = 3500 \left(\frac{144.9}{156.7}\right)^{1/2} \quad \text{or} \quad 3500 \left(\frac{44.17}{47.76}\right)^{1/2} = 3366 \text{ rpm} \quad (\text{Eq. 5})$$

The speed change is

$$\frac{3500 - 3365}{3500} \times 100 = 3.9\%$$

**EXAMPLE 2** With change in suction pressure—first conditions: same as Example 1.

Second conditions: same as Example 1, except

$$\begin{aligned} H_s &= 110 \text{ ft (33.5 m)} \\ H &= (193 - 110) + 1.9 = 84.9 \text{ ft (25.88 m)} \quad (\text{Eq. 3}) \end{aligned}$$

Operating point *B'* and other curves related to this example are shown in Figure 1. Again by trial and error, the flow rate and pump head at the intersection of the affinity curve and the 3500-rpm pump curve (point *A'*) are 134 gpm (30.4 m<sup>3</sup>/h) and 152.4 ft (46.45 m). The speed at the operating point is

$$N_2 = 3500 \left(\frac{100}{134}\right) \quad \text{or} \quad 3500 \left(\frac{22.7}{30.4}\right) = 2612 \text{ rpm} \quad (\text{Eq. 4})$$



Check:

$$N_2 = 3500 \left( \frac{84.9}{152.4} \right)^{1/2} \quad \text{or} \quad 3500 \left( \frac{25.88}{46.45} \right)^{1/2} = 2612 \text{ rpm} \quad (\text{Eq. 5})$$

The speed change is

$$\frac{3500 - 2612}{3500} \times 100 = 25.4\%$$

These examples indicate that the speed of the pump is not significantly affected unless there is an appreciable change in suction pressure.

For optimum performance, it should be confirmed, after the speed has been determined, that the most often occurring flow demand range is ideally near the pump's maximum efficiency.

Generally, the design point at maximum speed should be selected to the right of the pump's best efficiency point. The operating flow range at different speeds should be within the hydraulically and mechanically stable ranges of the pump.

The pump shaft power at any specified speed is

$$\begin{aligned} \text{in USCS units} \quad \quad \quad \text{hp} &= \frac{QH(\text{sp. gr.})}{3960E} \\ \text{in SI units} \quad \quad \quad \text{kW} &= \frac{QH(\text{sp. gr.})}{367E} \end{aligned} \quad (7)$$

where  $H$  = pump total head, ft (m)

$Q$  = flow rate, gpm ( $\text{m}^3/\text{h}$ )

sp. gr. = specific gravity of fluid

$E$  = pump efficiency, % (expressed in decimal equivalent)

$H$ ,  $Q$ , and  $E$  are values from the pump performance curve for the specified speed and impeller size.

The motor power is the same as the shaft power for pumps driven directly by the motor. For pumps driven through intermediate variable-speed couplings, the motor power must also include the drive slip and fixed losses.

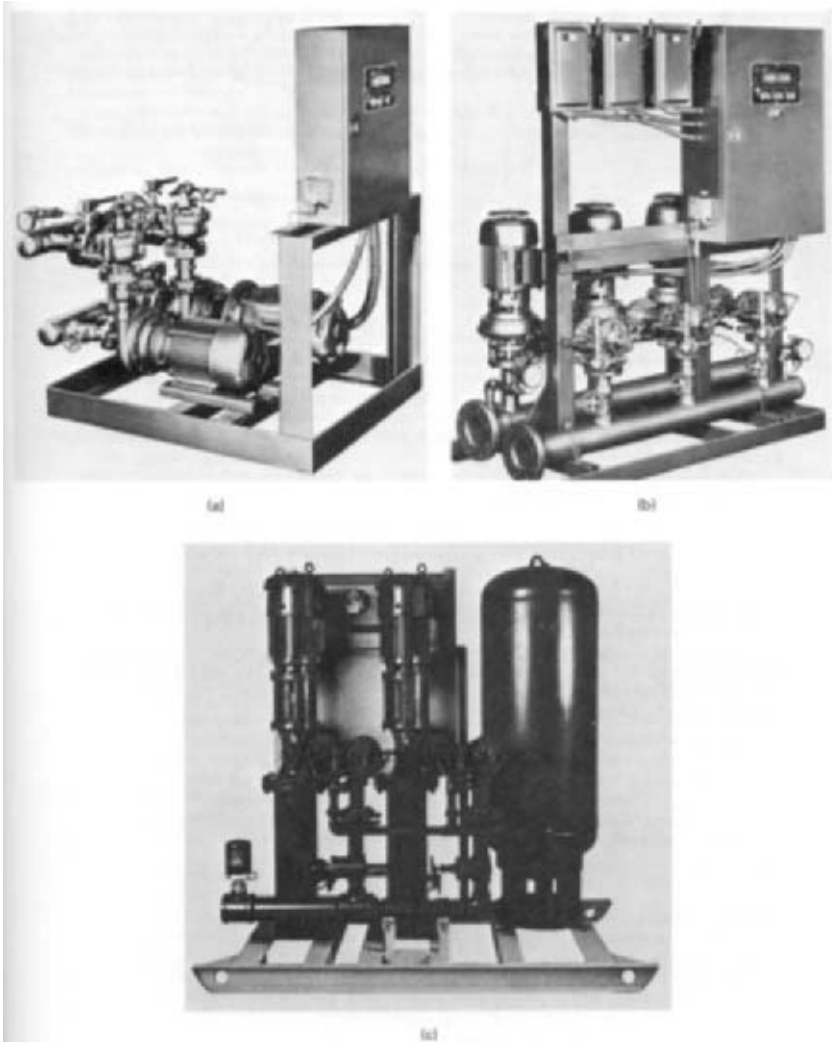
When the required design flow exceeds the capacity of a single pump, several pumps, including possibly one constant-speed unit, can be arranged to operate in parallel. Two methods of staging the pumps are usually used:

1. The first pump is operated in the variable-speed mode until its maximum speed is reached; the second pump, also a variable-speed unit, is energized. Now both pumps are operating in parallel at the same reduced speed. This sequence is repeated for the other pumps.
2. The first pump is operated in the variable-speed mode until its maximum speed is reached and is then locked in at this speed to operate as a constant-speed pump. The second pump is energized and operates in the variable-speed mode. The sequence is repeated for the other pumps. The speed variation of the second pump is relatively small because it must develop the same head as the first pump operating at maximum speed. Because the flow rate through the second pump is less, its speed is affected by the increase in total head available from the rise in the pump performance curve.

Which method of sequencing is selected depends on economics, equipment redundancy, and other considerations. For example, with the first method, both pumps must be furnished with variable-speed drive units. With the second method, only one variable-speed drive unit is required if it is an electronic type because the first pump is locked in by separate electric means.

The sole function of the pumps is to maintain constant pressure at the control point; therefore, the controller selected must be pressure-actuated. The type (follower signal) of controller chosen depends on the type of speed change signal acceptable by the variable-speed control unit. For electronic motor speed controls, such as variable-voltage and variable-frequency units, typical follower signals are low-voltage dc, milliamp dc, 135-ohm potentiometer, and pneumatic.

**Tankless Constant-Speed Multiple-Pump System** The major components of this system (Figure 2) are



**FIGURE 2** Constant-speed multiple-pump pressure booster systems: (a) horizontal end-suction volute pumps (ITT Bell and Gossett), (b) vertical end-suction volute pumps (ITT Bell and Gossett), (c) vertical turbine pumps with limited storage (SynchroFlo)

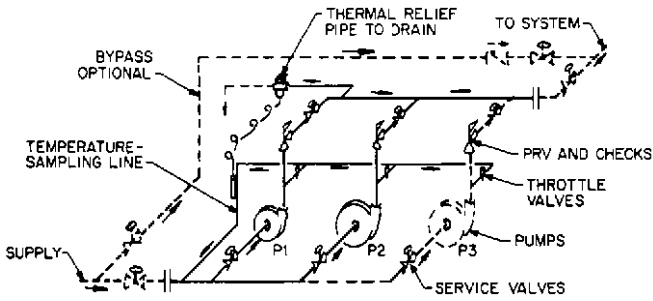


FIGURE 3 Constant-speed multiple-pump pressure booster schematic (ITT Bell and Gossett)

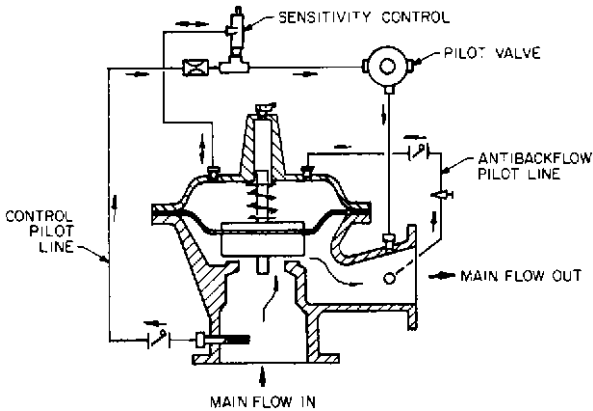


FIGURE 4 Typical pressure-reducing and check valve to maintain constant system pressure and prevent backflow (Cla-Val)

1. One or more pumps, with two or three most common
2. A combination pressure-reducing and check valve (PRCV) for each pump (parallel-piped PRCVs are used with larger sizes; separate pressure-reducing valves and check valves may be used)
3. An automatic sequencing control panel
4. When factory assembled, a steel frame for the entire unit

**PIPING ARRANGEMENT AND FLOW PATH** A schematic of the piping arrangement and flow path in a constant-speed multiple-pump system is shown in Figure 3. Supply water under fluctuating pressure enters the suction header and flows into the pump, where it is boosted to a higher pressure. This varying high-pressure water enters the PRCV (Figure 4), and the pressure is reduced to the constant pressure desired over the design flow range. Flow reversals through the idle and parallel pump circuits are prevented by the checking feature of the PRCV, which also dampens the pressure fluctuations caused by sudden flow changes.

When only minor changes in supply water pressure are anticipated, such as from a nonpressurized tank, and the pump head-capacity curve is relatively flat, silent check valves without pressure-reducing feature may be used. This will result in a slight increase in discharge pressure above the desired design constant pressure. When pumps of different sizes are used, care should be exercised to avoid having the higher-head pump force

the lower-head pump to shut off or to operate at less than minimum design pump flow. A decrease in flow from a centrifugal pump must be accompanied by an increase in pump total head as required by the pump head-capacity curve. If check valves only are used, it is preferable to have all pumps and valves identical to avoid unbalanced flows.

Operating the pumps at shutoff (no flow) will cause the water temperature in the pump castings to rise (Subsection 2.3.1). To keep the temperature in the pumps within a safe limit, the heated water is relieved through the thermal relief valve. This valve may be either a self-actuated (thermostatic) type or a solenoid valve actuated by a temperature controller.

**PUMP CONTROL PANEL** One of the advantages of a factory-assembled pressure booster package is the prewired, pretested, pretubed, mounted control panel that requires a minimum of field connections. In addition to providing for the proper sequencing of the pumps, the control panel should contain electrical interlocks for the operating and safety controls and circuit connections for remote control units.

Standard items and optional equipment vary considerably from one manufacturer to another. The components usually included with a standard panel are listed:

Steel enclosure	Starters
Control transformer	Sequencing controllers
Control circuit protector	Pump failure interlocks
Selector switches	Minimum-run timers
Low-suction pressure control	Time delays
	Pilot lights

Optional features that may be available:

Power supply fused disconnects or circuit breakers	Low system pressure control
Enclosure door interlock	Low water level control
High water temperature control	Emergency power switchover
High system pressure control	Unit failure alarm
Pump alternation	Low-flow shutdown
Program time switch	Miscellaneous enclosure types
Elapsed time meters	Power economizer circuit
	Additional pilot lights

Most factory-wired panels conform to one or more of the consumer safety agencies, such as Underwriters' Laboratories (UL), National Electrical Code (NFPA/NEC), and Canadian Standards Association (CSA) and are furnished with a label so indicating.

**PUMP CONTROL SEQUENCE** A typical elementary wiring diagram provides the following sequences of events. With both pump selector switches in the auto mode and all safety and operating controls in run status, the lead pump starter is energized, starting pump 1. As the system water demand increases, a staging control switch, which senses motor current, flow, or system pressure, starts pump 2. Pump 2 continues to operate until the decreasing water demand causes the staging control switch to open, stopping pump 2. If the circuit is provided with a minimum-run timer, pump 2 will continue to run for the set time period regardless of the staging switch status. This timer prevents pump 2 from short-cycling during rapidly fluctuating demand periods.

For test purposes and emergency operation, both pumps may be operated by placing the selector switches in the *hand* mode. In this position, most of the safety and operating controls are bypassed.

Should pump starter 1 fail to operate because of an overload heater relay trip or starter malfunction, a failure interlock switch automatically starts pump 2.

Pump 1 will run continuously unless the circuit is provided with shutdown features, such as high-suction pressure control and/or low-flow shutdown control.

Many units are specified for manual or automatic alternation of the equally sized pumps. This feature is intended to equalize the wear among the pumps and associated components. Alternation of any pump designated for *standby duty* (emergency use) may not be prudent. The standby pump should be preserved until needed, similar to an emergency power generator.

**Limited-Storage Constant-Speed Multiple-Pump System** The most notable shortcoming of the tankless multiple-pump system is the need for a continuously running pump, even at zero water usage. This drawback is remedied by the addition of a pressurized storage tank connected to the high-pressure side of the piping system with low-flow shutdown controls to stop the pumps.

The limited-storage system is not a scaled-down version of the hydropneumatic system. It differs in three important aspects:

1. The primary function of the tank is water storage.
2. Tank pressure is developed by the booster pump.
3. Air and water in the tank are separated by a flexible barrier (diaphragm, bladder) to eliminate direct interaction between the gas and water in the tank. The barrier also prevents the gas from escaping when the tank is emptied of water.

**SEQUENCE OF OPERATION CONTROL CIRCUITRY** During periods of normal water usage, the operating sequence is that of the tankless unit. As the water flow approaches zero, a low-flow sensing device stops the pumps. The tank provides the water needs during the shutdown period until the water pressure diminishes to the minimum allowable value. At this time, a pressure switch starts the lead pump to restore the pressure and recharge the tank with water.

The low-flow device may be a flow switch, a pressure switch, or a temperature-actuated switch and must be capable of switching at flows below 5 gpm (1.14 m<sup>3</sup>/h).

The tank should be sized for sufficient drawdown volume (water available from tank during shutdown) to avoid excessive pump cycling.

**RELATIONSHIPS BETWEEN TANK SIZE, DRAWDOWN VOLUME, AND PRESSURE** The approximate formula for sizing prepressurized diaphragm tanks at constant temperature is

$$V_t = \frac{V_e}{1 - \frac{P_f}{P_0}} \quad (8)$$

where  $V_t$  = tank volume, ft<sup>3</sup> (m<sup>3</sup>)

$V_e$  = change of gas volume in tank, ft<sup>3</sup> (m<sup>3</sup>)

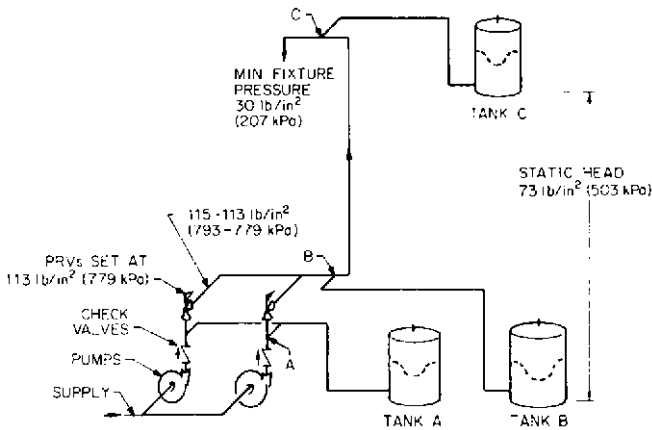
$P_f$  = final gas pressure lb/in<sup>2</sup> (kPa) abs

$P_0$  = initial gas pressure, lb/in<sup>2</sup> (kPa) abs

The corresponding relationships of water volume and pressures in the tank are

- $V_e$  is equal to the drawdown volume.
- $P_f$  is the water pressure at the end of the drawdown cycle, the minimum allowable system pressure.
- $P_0$  is the water pressure at the beginning of the drawdown cycle or at the termination of the charging cycle.

**TANK LOCATION** Because both  $P_f$  and  $P_0$  are influenced by the static head above the tank and the available charging pressure, the location of the tank and point of connection to the system should be carefully selected. Connecting the tank at A in Figure 5 provides the highest available tank charging pressure because this pressure is not affected by the reduction through the PRVs. However, there are several disadvantages to this point of connection:



Tank Location Comparisons

Tank location	Drawdown volume		Tank size		Min. operating pressure		Max operating pressure	
	gal	(liters)	gal	(liters)	lb/in <sup>2</sup>	(kPa)	lb/in <sup>2</sup>	(kPa)
A	20	(76)	128	(484)	104	(717)	126 <sup>a</sup>	(869) <sup>a</sup>
B	20	(76)	216	(818)	103	(710)	115	(793)
C	20	(76)	95	(360)	30	(207)	42	(290)

<sup>a</sup>Higher when suction pressure rises above design pressure

**FIGURE 5** Relative effect of tank location on tank size and pressure for equal draw-down volumes (ITT Bell and Gossett)

1. The highest static pressure is applied to the tank because the pumps are usually located on the lowest floor of the building.
2. The tank may be subjected to high working pressure because any increase in suction pressure above the minimum design pressure is additive to the pump head.
3. The tank and all alternated lead pumps must be interconnected.
4. A silent check valve must be placed between the tank connection point and the pump discharge nozzle.

Connecting the tank in *B* in Figure 5, downstream of the PRVs, will eliminate disadvantages 2, 3, and 4. The available charging pressure is less, and therefore a larger tank is required. However, tank location is not critical.

Locating the tank on the upper elevation of the building, such as at *C*, reduces the static head pressure on it; consequently, a smaller tank will suffice. The maximum design working pressure is also lower, and therefore it may be possible to use a tank with a lower pressure rating at less cost.

## PRESSURE BOOSTER SYSTEM SIZING

**Design Data** The proper sizing of a pressure booster system is subject to the accuracy of the design data available. Experience has indicated that the greatest single cause for unsatisfactory pressure booster performance is oversizing. Submitted data may be rough estimates or historical data not relevant to the location; therefore, their source and accuracy

should be scrutinized. Pertinent factors are the flow demand rate and hourly profile, pressure conditions, and types of building occupancy.

**FLOW DEMAND RATE AND HOURLY PROFILE** Estimating water demand rate is one of the most difficult and controversial subjects. To determine the water demand, many designers refer to the classical Hunter curve (National Bureau of Standards, Report BMS79, by R. B. Hunter) or a modified version of it for lack of a more accurate method. Numerous studies have indicated that the Hunter method often results in very appreciable demand rate overstatement. It should be noted that the Hunter curve was intended for determining pipe sizes, not water demand.

The average hourly demand profile is helpful in proportioning the system demand rate among the pumps in the system. Optimum selection results in the lowest total energy consumption by the pumps while maintaining the demand requirements.

**PRESSURE CONDITIONS** Four accurate pressure values are required: design system pressure, minimum suction pressure, maximum suction pressure, and minimum allowable system pressure. The difference between design system pressure and minimum suction pressure is used to determine the developed head of the pump at design flow. Inaccurate values will result in incorrect impeller sizing and incorrect motor power selection.

The design system pressure can be calculated with reasonable accuracy. However, when the water supply is from the municipal water main, obtaining accurate values of suction pressures for the proposed site of installation is very difficult because of the absence of recent pressure data. Often the minimum and maximum pressures are haphazardly estimated from average citywide values. A minimum suction pressure error as small as 5 lb/in<sup>2</sup> (35 kPa) could result in selection of the next larger motor.

The maximum suction pressure will determine the working pressures required of the pumps and piping and whether there is sufficient pressure to justify a bypass connection (Figure 3) paralleling the pumps.

Knowing the minimum allowable system pressure is helpful in setting controls associated with this pressure.

**TYPE OF OCCUPANCY** If the hourly demand profile is not available, the type of building occupancy could be used to determine the standby capacity requirement, whether low-flow shutdown is applicable, and the number of pumps for the system. Most pressure booster manufacturers provide data for determining demand, capacity splits, and pump sizing.

**Pump Sizing Procedures** Information should be collected on system information and component performance. The system information required is

$Q_d$  = total design capacity, gpm (m<sup>3</sup>/h)

$P_d$  = design pressure at system header outlet, lb/in<sup>2</sup> (kPa)

$P_s$  = minimum available pressure at suction header inlet, lb/in<sup>2</sup> (kPa)

$Q_1, Q_2, Q_3$  = design capacity of individual pumps, gpm (m<sup>3</sup>/h)

Components performance data required are

- Pump performance characteristic curve
- Pressure-reducing valve (and check valve) flow chart\* (Figure 6)

Next, the required pump total head at the maximum flow design condition should be calculated:

$$H = (H_d - H_s) + H_v + H_u \quad (9)$$

where  $H$  = required total head, ft (m)

$H_d$  = design system pressure at PRCV outlet, ft (m)

\*Add loss through separate check valve if not integral with PRV.

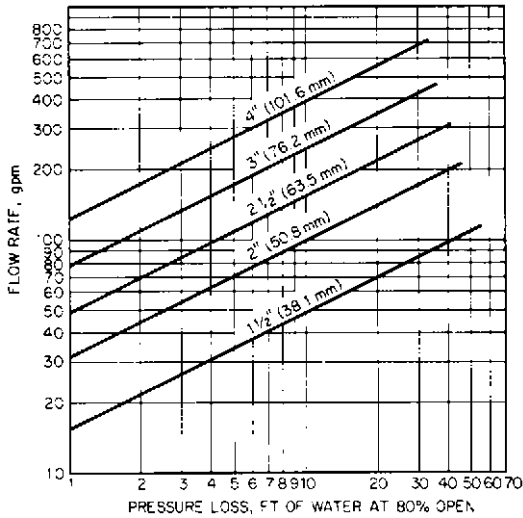


FIGURE 6 Typical PRV or PRCV flow chart ( $\text{ft} \times 0.3048 = \text{m}$ ;  $\text{gpm} \times 0.2271 = \text{m}^3/\text{h}$ ;  $\text{in} \times 25.4 = \text{mm}$ ) (Cla-Val)

$H_s$  = minimum design suction pressure, ft (m)

$H_v$  = PRCV pressure loss, ft (m)\*

$H_u$  = sum of all unaccounted losses in the pressure booster package, ft (m)

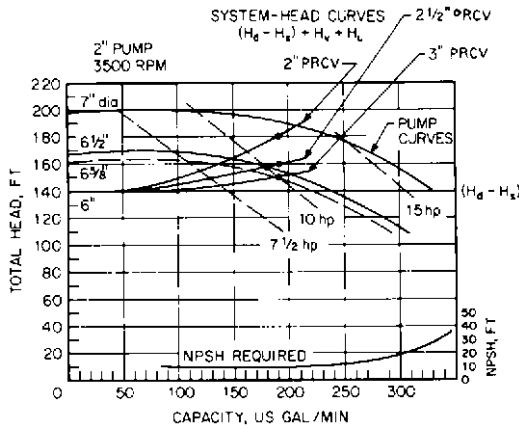
For pressure booster applications, the PRCV is usually sized for a nominal pipe velocity between 8 and 18 ft/s (2.4 and 5.5 m/s). The pressure loss  $H_v$  is based on the valve being 80% open (Figure 6). Operating the valve at less than full-open position is desirable for good pressure regulation. The term  $H_u$  represents the allowance for piping frictional losses between the suction header inlet and the system header outlet at design capacity, exclusive of the PRCV loss. Manufacturers of booster packages differ in determining this value. Some ignore it completely to compensate for usual oversizing as the result of inaccuracies in the design capacity and minimum suction pressure statements. Others assign a fixed value, about 5 ft (1.5 m), or a percentage, about 3%, of the difference of system and suction pressures ( $H_d - H_s$ ). It is recommended that some value be used.

Then determine the best combination of pump and PRCV sizes. The selection will depend on whether the design criterion is least capital cost or lowest operating cost. Usually the smallest pump and PRCV combination will result in lowest first cost and the pump equipped with the smallest motor will yield the lowest operating cost. Various pump, PRCV, and motor combinations may be examined by plotting system curves (Figure 7) for two or three PRCV sizes on one or more pump performance curves.

The pumps tentatively selected should exhibit the highest efficiency at the most frequent operating flow point on their head-capacity curves. When pumps are operated at suction pressures higher than design minimum, the PRCVs will throttle the excess suction head and maintain the same pump total head and constant design discharge pressure. When the flow demand is less than the design maximum, characteristically, the head on the centrifugal pumps will increase to some higher value on the pump head-capacity curve. The PRCVs will reduce this excess head to maintain the constant design discharge pressure. Therefore, each pump operates along its own head-capacity curve, which is also the adjusted system-head curve.

Add loss through separate check valve if not integral with PRV.





**FIGURE 7** System curves for PRCV sizing (ft × 0.3048 = m; gpm × 0.2271 = m<sup>3</sup>/h; hp × 0.7457 = kW; in × 25.4 = mm) (ITT Bell and Gossett)

When several pumps are to be used, especially pumps of different sizes, their head-capacity characteristics should be compatible. A pump having a shutoff total head less than the system total head at any operating point (with or without other pumps operating) will not pump. Also, pumps should be so selected and controls should be such that no one pump will operate at too low a flow; that is, at a flow less than the minimum recommended for mechanical and hydraulic stability. If the minimum suction pressure is very low, the net positive suction head required by the pumps throughout their operating flow range must be checked (Subsection 2.3.1).

**PUMP AND PRCV SELECTION EXAMPLE**

Total system design capacity	$Q_d = 380 \text{ gpm (} 86.3 \text{ m}^3/\text{h)}$
Design capacity	$Q_1, Q_2 = 190 \text{ gpm (} 43.1 \text{ m}^3/\text{h)}$
Design pressure at system header outlet	$H_d = 210 \text{ ft (} 64.0 \text{ m)}$
Minimum pressure at suction header	$H_s = 70 \text{ ft at } 100 \text{ ft NPSH inlet (} 21.3 \text{ m at } 30.5 \text{ m NPSH)}$
PRCV loss, Figure 6	$H_v = 36 \text{ ft (} 11 \text{ m) for trial 2-in (} 51\text{-mm) valve}$
Allowance for internal frictional losses	$H_u = 5 \text{ ft (} 1.5\text{m)}$

Calculate  $H$ :

In USCS units  $H = (210 - 70) + 36 + 5 = 181 \text{ ft}^*$  (Eq. 9)

In SI units  $H = (64.0 - 21.3) + 11 + 1.5 = 55.2 \text{ m}$

Table 2, calculate and tabulate  $H$  for all applicable PRCV sizes up to the design flow rate of 190 gpm (43.1 m<sup>3</sup>/h).  $H_v$  and  $H_u$  terms vary as the square of the flow rate.

Now locate  $H$  at 190 gpm (43.1 m<sup>3</sup>/h) on the applicable pump curve. Select the pump and PRCV combination that best satisfies the design criterion of least first cost or lowest energy input.

\*Due to the many approximations, decimal amounts are not used in the final results.

**TABLE 2** Required head for pressure reducing valves

PRV size, in (mm)	Flow, gpm (m <sup>3</sup> /h)				
	0 (0)	50 (11)	100 (23)	150 (34)	190 (43)
2 (51)	140 (42.7)	143 (43.6)	151 (46.0)	166 (50.6)	181 (55.2)
2½ (64)	140 (42.7)	141 (43.0)	146 (44.5)	153 (46.6)	160 (48.8)
3 (76)	140 (42.7)	141 (43.0)	143 (43.6)	147 (44.8)	151 (46.0)

Note: All values are head in ft (m).

Plot  $H$  values on the selected pump curve to obtain the system curves for the three PRCV sizes (Figure 7). The plots reveal that the 3-in (76-mm) valve, a 10-hp (7.5-kW) motor, and 6⅜-in diameter (162-mm) impeller are the proper selections.

Note that if the design capacity of the pump could be reduced to about 178 gpm (40.4 m<sup>3</sup>/h, a 2½-in (64-mm) PRCV with the impeller sized for 6½-in (165-mm) diameter may be used without additional power input. This choice reduces the cost and improves the PRCV performance at low flow rates.

Using a 2-in (51-mm) PRCV would require a 15-hp (11-kW) motor operating at about 12.5 hp (9.3 kW) load. This choice is not energy effective.

The power required to drive the pump may be approximated by using the pump curve and Eq. 7. The available  $NPSH$  is in excess of the required pump  $NPSH$  (Figure 7).

## PUMP TYPES AND MATERIALS

Single-stage volute centrifugal pumps, followed by multistage vertical turbine diffuser pumps in a suction tank, are most commonly used for domestic water pressure booster systems. The volute pumps can be end-suction with a vertically split case, double-suction with an axially split case, or in-line. For high-pressure service, two-stage axially split case pumps or multistage vertical turbine pumps may be selected.

In selecting the type of pump best suited for the application, such inherent characteristics as low-flow recirculation, low-flow cavitation, high-flow cavitation, steepness of the pump curve, noise, and operating efficiencies should be evaluated. These factors are discussed in Subsection 2.3.1.

The most often discussed factor in booster application is low-flow recirculation. Low pump flow conditions do occur; they cannot be completely designed out of the system. Most well-designed small pumps with positive (above atmospheric) suction pressure can operate safely in the low-flow region, with the only point of concern being water temperature rise at or near shutoff flow. Should radial thrust be a major consideration, double-volute pumps or diffuser (vertical turbine) pumps offer advantages.

Vertical pumps generally require less space. Pumps may be close-coupled to their drivers, or, if not, a coupling requiring careful alignment is required. Close-coupled pumps may require less maintenance, as there are no pump bearings. Shaft sealing may be either packing or mechanical seal.

All pumps and drivers in packaged units are mounted on a common steel frame, but individual bases for each pump and driver may be necessary for larger units.

The materials of construction for pumps, valves, and piping should be suitable for the water quality and conditions furnished to the system. Because water impurities vary from location to location, careful analysis is recommended. Federal and local agencies, such as the Food and Drug Administration, may also prescribe allowable materials.

## FURTHER READING

American Society of Heating, Refrigerating, and Air-Conditioning Engineers. *Equipment Handbook*, ASHRAE, Atlanta, GA, 1983.

ITT Bell and Gossett. "Domestic Water Service." Bulletin TEH-1175, Morton Grove, IL, 1970.

ITT Fluid Handling Division. "Pressurized Expansion Tank Sizing/Installation." Bulletin TEH981, Morton Grove, IL, 1981.

Potter, P. J. *Steam Power Plants*, Ronald Press, New York, 1949.

Steel, A. *High Rise Plumbing Design*, Miramar, Los Angeles, 1975.

---

# SECTION 9.22

---

# HYDRAULIC PRESSES

---

A. B. ZEITLIN

## **TYPES OF PRESSES**

---

Hydraulic presses, both vertical and horizontal, are used in many industrial technologies. Vertical press applications include forging presses with flat dies, used for hot work to break down ingots and shape them into rolls, pressure vessels (mandrel forgings), forged bars, rods, plates, and so on; forging presses with closed dies, used to process preheated billets into various shapes, such as aircraft bulkheads, engine supports, and main fuselage and wing beams; and upsetting presses, used for the production of items with elongated shafts—long hollow bushings, pipes, vessels, and so on. Horizontal presses are used primarily for conventional hot extrusion. Cold hydrostatic extrusion is finding application in the production of various end products and bulk items, such as very thin wire in long strands.

## **ACCUMULATORS**

---

Until about 1932, all power systems for hydraulic presses were operated with water. With the advent of reliable, fast, high-pressure oil pumps, a trend of significantly less expensive oil pumps developed.

Installations requiring a relatively uniform and constant supply of hydraulic power are preferably designed with drives drawing the pressurized liquid directly from the pumps. In installations with high power (and liquid) peak demands of short duration, it is in most cases advantageous to arrange for a constant average flow of pressurized liquid from the pumps while providing equipment in which pressurized liquid can be stored in times of low demand and from which liquid can be drawn during demand peaks. These storage

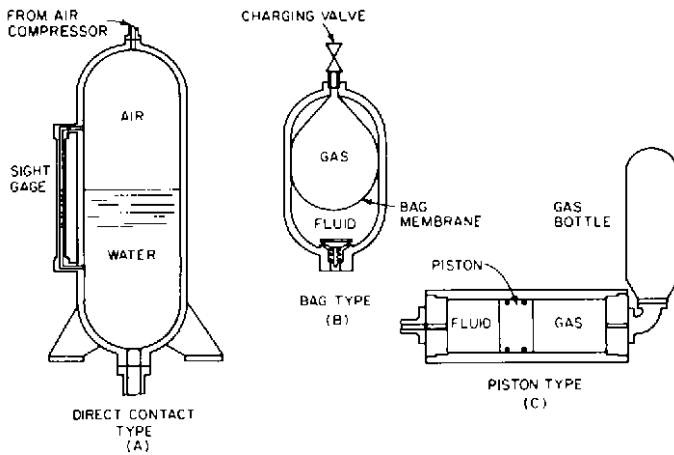


FIGURE 1A through C Accumulators

facilities are called accumulators and are illustrated in Figure 1. A modern accumulator is buffered by a large pressurized gas (mostly air) cushion.

Until about 1960, the direct-contact surface between gas and liquid virtually precluded the use of oil in accumulator installations for larger presses. Gas diffuses into oil under pressure. When oil is discharged from the press at the end of the pressing cycle, the gas begins to bubble out of the liquid; the liquid foams, and because of its large volume, this foam is difficult to handle. This condition exists whether the pneumatic cushion is air or nitrogen. In addition, if air is used as the pneumatic cushion, the oxygen diffused into the oil oxidizes it, producing sludge and gum. (Spring- and weight-loaded accumulator installations have other serious drawbacks and have almost completely disappeared.)

A modification of the accumulator station uses a floating piston to separate oil from the pneumatic cushion (Figure 1C). This design eliminates foaming and oxidizing, thus allowing the inclusion of accumulators into oil systems.

Power plants operated with water are used exclusively in special cases (for instance, where extreme precaution must be taken against fires caused by leaking oil). The increasing viscosity of oil precludes the use of oil at very high pressures.

## CENTRIFUGAL VERSUS RECIPROCATING PUMPS

The competition between centrifugal and reciprocating pumps for hydraulic presses has been decisively won by reciprocating pumps. Under full load, centrifugal pumps have higher efficiency than reciprocating pumps (Figure 2). However, in press installations, the power plants are idle a significant portion of the time. The losses during idling are only about 10% of full load for reciprocating pumps and well over 60 to 70% for centrifugal units. The total combined losses in installations with reciprocating pumps are less than half the losses in centrifugal pump plants, as shown in Figures 3 and 4.

Reciprocating pumps for hydraulic presses that use water as the hydraulic medium are generally of the single-acting multiplunger type. Although there are large installations in operation using double-acting pumps, the faster vertical single-acting pump, which requires less floor space, offers a considerable saving in capital expenditure and has proved itself dependable in service. In most cases, this type of pump is used in conjunction with an accumulator, which allows the averaging of demand and thus a reduction in required pump capacity. There are, however, installations in which a vertical single-acting pump drives hydraulic cylinders directly.

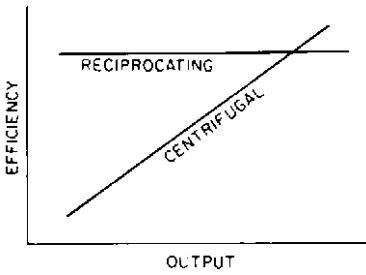


FIGURE 2 Comparison of pump efficiency

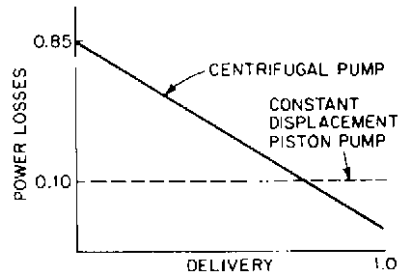


FIGURE 3 Comparison of pump power losses

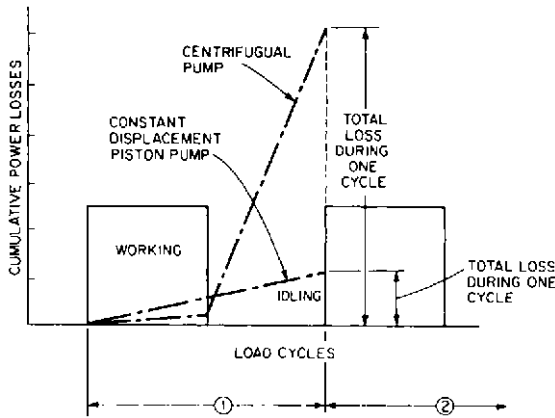


FIGURE 4 Comparison of load cycling losses

Idling is controlled by remotely operated bypass valves or pump suction valve lifters that take command from the operator, accumulator level control, or some other sensor-monitoring press action.

Oil pumps most commonly used for the power strokes of presses are

1. Vane rotary constant-delivery pumps, generally for pressures not in excess of 2500 lb/in<sup>2</sup> (17,200 kPa)
2. Piston rotary constant-delivery pumps
3. Piston rotary variable-delivery pumps

The constant-delivery pumps require a bypass system for idling. This is generally accomplished by an arrangement of directional control valves or by relief bypass valves.

The variable-delivery pump has the advantage of providing efficient press speed control and idling by an adjustment of piston stroke. In cases of multiple pump application, constant- and variable-delivery pumps are often used jointly, their selection depending on the speed ranges required. It is possible to obtain these pumps designed for use with non-flammable liquid as a hydraulic medium.

Generally, both water and oil pumps in press applications are driven directly by electric motors, the motor speed matching the pump speed. Sometimes, on large water pumps, a geared speed reducer is installed between motor and pump.

## OPERATING PRESSURES

Operating pressures in hydraulic presses have been slowly moving upward. The most popular level for water hydraulic installations is a rated pressure of 5000 lb/in<sup>2</sup> (34,500 kPa) and an actual operating pressure of 4500 lb/in<sup>2</sup> (31,000 kPa). Intensifiers are used to raise this pressure to between 6750 and 7500 lb/in<sup>2</sup> (46,500 and 51,700 kPa) in large presses, which corresponds to a rated power of from 7000 tons (62,300 N) upward. When used, the intensifiers are installed between the accumulators (and pump) on the low side and the press on the high side. A bypass is always provided. For very large presses, pressures of up to 15,000 lb/in<sup>2</sup> (10,300 kPa) have been suggested. In the former Soviet Union, designers are using 15,000 lb/in<sup>2</sup> (10,300 kPa) regularly.

In oil hydraulic installations, 3000 lb/in<sup>2</sup> (20,700 kPa) is the most popular pressure because of the availability of 3000-lb/in<sup>2</sup> (20,700-kPa) equipment from many reputable firms (pumps, valves, fittings, and so on). However, there are now on the market excellent units for pressures up to 6600 lb/in<sup>2</sup> (45,500 kPa), and the tendency in new installations is to provide 5000 lb/in<sup>2</sup> (34,500 kPa). Today, oil pumps for pressures as high as 9000 to 15,000 lb/in<sup>2</sup> (62,000 to 103,500 kPa) are being offered.

In the field of what is called ultrahigh-pressure equipment, pumps with direct action up to 225,000 lb/in<sup>2</sup> (1.55 MPa) are available today.

## DESIGN PROCEDURE

Considerations and calculations required to dimension the hydraulic power plant for a hydraulic press are given in Table 1. A standardized procedure for determining the basic design features of the power plant for a hydraulic press is offered in the left column. The right column gives an example of how the standard procedure should be used. The press selected for the example is an open die press for forging ingots into billets or bars through gradual reduction of cross section on narrow, flat dies that, at each stroke, penetrate several inches into the hot metal (cogging). The ingot is advanced and rotated, and, when it is close to the desired size, the surface is made smooth by the application of shallow-penetration— $\frac{1}{8}$ - to  $\frac{1}{2}$ -in (0.32- to 1.27-cm)—fast strokes (planishing) of the press (Figure 5).

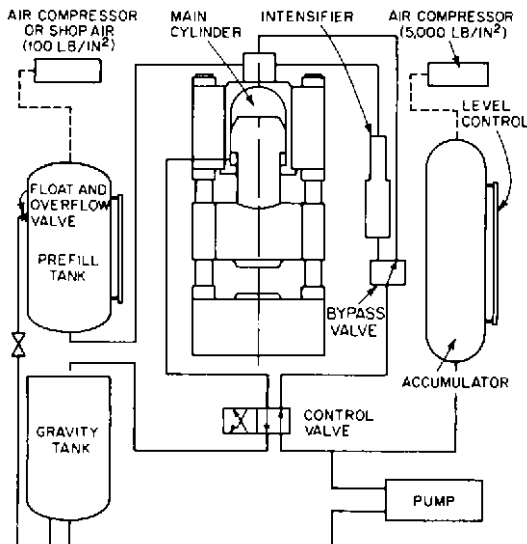


FIGURE 5 Vertical forging press with double-acting cylinder

**TABLE 1** Example of power plant design for a hydraulic press

Standard Procedure

1. Water or oil can be used as the liquid in a hydraulic system of a vertical or horizontal press. The decision can be made in accordance with the general discussion in this section. The generation of full pressure during planishing is not required; because of rapid stroking, there would not be enough time to pressurize the liquid fully and expand the cylinder fully. The pull-back cylinders are kept continuously under pressure during planishing, thus reducing the time required for valving. The generation of about 10% of nominally rated pressure is considered sufficient for planishing.

2. Select operating pressure  $p$  in pounds per square inch (megapascals) of the hydraulic system.
3. Determine the required effective pressing area  $A$  in square inches (square centimeters) of the main plunger of the press:

$$A = \frac{T \times 2000}{p}$$

where  $T$  is the rated power in tons (newtons).

Example

Requirements:

Press rating  $T = 6000$  tons (53 MN)

Pull-back rating  $T_R = 600$  tons (5.3 MN)

Total stroke  $S_t = 48$  in (122 cm)

Maximum pressing stroke  $S_p = 12$  in (30 cm)

Fast advance speed  $v_a = 360$  in/min = 6 in/s (5 cm/s) minimum

Fast return speed  $v_r = 360$  in/min = 6 in/s (15 cm/s) minimum

Pressing speed  $V_p$  required:

At full 6000-ton (53-MN) rating: 120 in/min 2 in/s (5 cm/s) maximum

At  $\frac{2}{3} = 4000$ -ton (36-MN) rating: 180 in/min = 3 in/s (8 cm/s) maximum

At  $\frac{1}{3} = 2000$ -ton (18-MN) rating: 360 in/min = 6 in/s (15 cm/s)

maximum

Rated operating cycles:

Cogging: 15 c/min, each cycle consisting of

Fast advance—4 in (10 cm)

Pressing—4 in (10 cm)

Return—8 in (20 cm)

Planishing: 80 c/min, each cycle consisting of

Advance— $\frac{1}{4}$  in (0.64 cm)

Pressing— $\frac{1}{4}$  in (0.64 cm)

Return— $\frac{1}{2}$  in (1.3 cm)

1. Selected: oil hydraulic system
2. Selected:  $p = 5000$  lb/in<sup>2</sup> (34 MPa)
3. in USCS units

$$A = \frac{6000 \times 2000}{5000} = 2400 \text{ in}^2$$

in SI units  $\frac{53}{34} = 1.55 \text{ m}^2 = 15,500 \text{ cm}^2$



**TABLE 1** Continued.

Standard Procedure

- Select the number of cylinders  $N_c$  comprising the main system of the press and their individual ratings  $T_1, T_2, T_3 \dots$
- Subdivide  $A$  in accordance with selected ratings and determine the individual diameters:  

$$D = \sqrt{\frac{A}{0.785}}$$

If any piston rods detract from the effective plunger area, their area should be added to  $A$  before determining  $D$ .

- Using the total stroke  $S_t$  and the rated pressing stroke  $S_p$ , determine the geometric volumes  $V_t$  and  $V_p$  corresponding to these strokes.
- Using a general compressibility curve, determine the compressibility  $c$  of the liquid between atmospheric pressure and rated operating pressure.

Example

- Select three cylinders.  
 Center cylinder  $T_2 = 4000$  tons (36 MN)  
 Two side cylinders  $T_1 = T_3 = 1000$  tons (8.9 MN)  
 Operating all three cylinders:  $T = 6000$  tons (53 MN)  
 Operating center cylinder alone: 4000 tons (36 MN)  
 Operating side cylinders alone: 2000 tons (18 MN)
- $A_1 = A_3 = \frac{1}{6} \times 2400 = 400 \text{ in}^2$  ( $\frac{1}{6} \times 15,500 = 2580 \text{ cm}^2$ )  
 $A_2 = \frac{4}{6} \times 2400 = 1600 \text{ in}^2$  ( $\frac{4}{6} \times 15,500 = 10,300 \text{ cm}^2$ )  
 $D_1 = D_3 = \sqrt{\frac{400}{0.785}} = 23 \text{ in}^a$  (58.4 cm)  
 Adjusted area  $A'_1 = A'_3 = 415 \text{ in}^2$  (2680 cm)  
 $D_2 = \sqrt{\frac{1600}{0.785}} = 45 \text{ in}^a$  (114 cm)  
 Adjusted area  $A'_2 = 1590 \text{ in}^2$  (10,200 cm<sup>2</sup>)  
 Total adjusted area  $A' = (2 \times 415) + 1590 = 2420 \text{ in}^2$  [(2 × 2680) + 10,200 = 15,600 cm<sup>2</sup>]
- $V_t = S_t \times A' = 48 \times 2420 = 116,160 \text{ in}^3$  (122 × 15,600 = 1,903,000 cm<sup>3</sup>)  
 For cogging  $V_{pc} = 4 \times 2420 = 9680 \text{ in}^3$  per cogging stroke (10 × 15,600 = 156,000 cm<sup>3</sup>)  
 For planishing  $V_{pp} = \frac{1}{4} \times 2420 = 605 \text{ in}^3$  per planishing stroke (0.635 × 15,600 = 9900 cm<sup>3</sup>)
- For 5000 lb/in<sup>2</sup> (34 MPa), the oil compressibility may be assumed at  $c_0 = 1.5\%$ .

<sup>a</sup>It is customary to select diameters of large plungers in full-inch or  $\frac{1}{2}$ -inch sizes; this requires adjustment of the area.

Standard Procedure

8. Assume a reasonable approximate level of hoop stresses  $s_h$  along the inner surface of the cylinder barrel. The cylinder diameter expansion will be

$$d_e = \frac{s_h}{E} \times D$$

where  $E$  = modulus of elasticity, assumed to be  $30 \times 10^6$  lb/in<sup>2</sup> (207 GPa)

9. On the basis of  $c_0$  and  $s_h$ , determine the volume of liquid required to compensate for compression of liquid  $V_{c1}$  as well as for expansion of cylinder  $V_{ec}$ . During planishing, the pressures rise to only about 10% of rated; therefore, the compressibility of the liquid and expansion of the cylinder may be neglected.

Example

8. Assume  $s_h = 30,000$  b/in<sup>2</sup> (207 MPa)

$$\text{Main cylinder } dem = \frac{30,000}{30 \times 10^6} \times 45 = 0.045 \text{ in}$$

$$\left( \frac{207}{207 \times 1000} \times 114 = 0.114 \text{ cm} \right)$$

$$\text{Side cylinders } des = \frac{30,000}{30 \times 10^6} \times 23 = 0.023 \text{ in}$$

$$\left( \frac{207}{207 \times 1000} \times 58.4 = 0.058 \text{ cm} \right)$$

where  $dem$  is the main cylinder diameter expansion and  $des$  is the side cylinder expansion.

9. Compression of the liquid takes place along the entire length of the cylinder barrel. Assuming the length of the barrel to be approximately  $S + \frac{1}{2}S$ , or  $48 + 25 = 72$  in ( $122 + 61 = 183$  cm):

$$V_{c1} = 72 \times 2420 \times 0.015 = 2614 \text{ in}^3$$

$$(183 \times 15,600 \times 0.015 = 42,800 \text{ cm}^3)$$

Omitting quantities small in the second order,

$$V_{ec} = 72 \frac{\pi}{4} \left( 2D \times \frac{30,000}{30 \times 10^6} \times D \right)$$

$$= 72 \times 1.57 \times 0.001 \times D^2 = 0.113 \times D^2 (183 \times 1.57 \times 0.001 \times D^2 = 0.287 \times D^2)$$

For the center cylinder:

$$V_{ec2} = 0.113 \times 45^2 = 229 \text{ in}^3 \quad (0.287 \times 114^2 = 3730 \text{ cm}^3)$$

For the side cylinders:

$$V_{ec1} = V_{ec3} = 0.113 \times 23^2 = 60 \text{ in}^3 \quad (0.287 \times 58.4^2 = 980 \text{ cm}^3)$$

$$V_{ec} = 229 + (2 \times 60) = 349 \text{ in}^3 \quad [3730 + (2 \times 980) = 5700 \text{ cm}^3]$$

Total additional volume of liquid required.

$$2614 + 349 = 2963 \text{ in}^3 \text{ per stroke} \quad (42,800 + 5700 = 48,500 \text{ cm}^3)$$

**TABLE 1** Continued.

Standard Procedure	Example
10. Determine the total amount of liquid $V$ required per cogging stroke.	10. $V = 9680 + 2963 = 12,643 \text{ in}^3$ ( $156,000 + 48,500 = 204,500 \text{ cm}^3$ ) This value shows what additional burden can be imposed on the power plant by unnecessarily generous dimensioning of the total stroke.
11. Check whether specified speeds are compatible with the required number of cogging strokes. If not, increase the specified speeds (or reduce the number of strokes).	11. Fast advance time: $\frac{4}{6} = 0.67 \text{ s}$ Pressing time: $\frac{4}{2} = 2 \text{ s}$ Fast return time: $\frac{6}{3} = 1.33 \text{ s}$ Valving time (3 switches) = 0.45 s Total cycle time = 4.45 s  This time is too long to allow 15 cogging strokes per minute. Increase fast advance and fast return to 480 in/min = 8 in/s (20 cm/s) and pressing to 180 in/min = 3 in/s (8 cm/s). Then
12. Determine the liquid requirements for the pull-back stroke (Figures 6 and 7). In general, the pull-back cylinders have an area equal to 10% of the area of the main cylinders and twice as long a stroke as the pressing stroke; in general, the required volume is therefore, with sufficient accuracy:	Fast advance time: $\frac{4}{8} = 0.5 \text{ s}$ Pressing time: $\frac{4}{3} = 1.33 \text{ s}$ Fast return time: $\frac{6}{6} = 1 \text{ s}$ Valving time = 0.45 s 12. $12,643 \times 0.2 = 2528 \text{ in}^3$ ( $204,500 \times 0.2 = 40,900 \text{ cm}^3$ )

$$V \times 0.1 \times 2 = 0.2 \times V$$

**TABLE 1** Continued.

**Standard Procedure**

13. Determine the pumping requirements for the pump station with or without an accumulator. Without an accumulator:

$$\text{gpm} = \frac{V \times 60}{231 \times t_p} \quad \left( \text{m}^3/\text{h} = \frac{V \times 60}{1000 \times t_p} \right)$$

where  $V$  is the volume in gallons (cubic meters) required for one pressing stroke and  $t_p$  is the pressing time in seconds.

With an accumulator:

$$\text{gpm (acc)} = \frac{V_{tc} \times 60}{231 \times t_c} \quad \left( \text{m}^3/\text{h} = \frac{V_{tc} \times 3600}{10^6 \times t_c} \right)$$

where  $V_{tc}$  is the total volume in gallons (cubic meters) of pressurized liquid required during one cycle and  $t_c$  is the cycle time in seconds.

14. Determine size of the accumulator required to store the accumulated volume  $V_s$  of liquid:

$$V_s = \text{gpm (acc)} \times \frac{t_c - t_p}{60} - V_R \quad \left( \text{m}^3/\text{h} \times \frac{t_c - t_p}{3600} - V_R \right)$$

where  $V_R$  is the volume required for the return stroke in gallons (cubic meters).

Air volume required, based on 10% pressure fluctuation for isothermic condition, is  $10V_s$ . For adiabatic or, more often, polytropic conditions and 10% pressure fluctuation, the air volume is

$$V_{\text{air}} = \frac{V_s}{1.11^{1/n} - 1}$$

Although  $n = 1.4$  is the exponent for adiabatic compression,  $n = 1.3$  is considered satisfactory, even for severe and demanding conditions, which require full utilization of press stroke and a fast cycle. Based on  $n = 1.3$ ,

$$V_{\text{air}} = 12V_s$$

**Example**

13. Without an accumulator:

$$\frac{12,643 \times 60}{231 \times 1.33} = 2469 \text{ gpm} \quad \left( \frac{204,500}{10^6 \times 1.33} = 553 \text{ m}^3/\text{h} \right)$$

With an accumulator:

$$\frac{(12,643 + 2,528) \times 60}{231 \times 4} = 985 \text{ gpm (acc)}$$

$$\left( \frac{(204,500 + 40,900) \times 3600}{10^6 \times 4} = 221 \text{ m}^3/\text{h (acc)} \right)$$

It is evident that the use of an accumulator will result in significant savings and in a substantial reduction of the peak load.

14.  $V_s = 985 \times \frac{4 - 1.33}{60} - \frac{2528}{231} = 32.9 \text{ gal} = \frac{32.9}{7.48} = 4.4 \text{ ft}^3$

$$\left( 224 \times \frac{4 - 1.33}{3600} - \frac{40,900}{10^6} = 0.125 \text{ m}^3 \right)$$

$$V_{\text{air (isometric)}} = 12 \times 32.9 = 395 \text{ gal} = 10 \times 4.4 = 44 \text{ ft}^3$$

$$(10 \times 0.125 = 1.5 \text{ m}^3)$$

$$V_{\text{air (polytropic)}} = 12 \times 32.9 = 395 \text{ gal} = \frac{395}{7.48} = 53 \text{ ft}^3$$

$$(12 \times 0.125 = 1.5 \text{ m}^3)$$

$$\text{Total accumulator volume} = 44 + 4.4 = 48.4 \text{ ft}^3$$

$$(1.25 + 0.125 = 1.38 \text{ m}^3)$$

$$= 53 + 4.4 = 57.4 \text{ ft}^3$$

$$(1.5 + 0.125 = 1.63 \text{ m}^3)$$

**TABLE 1** Continued.

Standard Procedure

15. Check planishing conditions.

Example

15. Timing:

$$\text{Fast advance: } \frac{1/4}{8} = 0.032 \text{ s}$$

$$\text{Pressing: } \frac{1/4}{3} = 0.084 \text{ s}$$

$$\text{Fast return: } \frac{1/2}{8} = 0.063 \text{ s}$$

$$\text{Valving (2 switches) = 0.3 s}$$

$$\text{Total = 0.479 s}$$

There will be more than enough time for 80 planishing strokes per minute. Only two valve switches are required for planishing because, during planishing, the pull-back cylinders are permanently connected to the pressure source.

During planishing, the pressure reaches only about 10% of rated; therefore compressibility and expansion require only 10% of the previously calculated amount. The pull-back system is constantly pressurized and does not require any liquid for compression of liquid and expansion of cylinder. The total requirements are thus

For the pressing stroke:

$$605 + 296 = 901 \text{ in}^3 \quad (9900 + 4850 = 14,750 \text{ cm}^3)$$

For the pull-back stroke:

$$605 \times 0.2 = 121 \text{ in}^3 \quad (9900 \times 0.2 = 1980 \text{ cm}^3)$$

$$\text{Total} = 1022 \text{ in}^3 \quad (= 16,730 \text{ cm}^3)$$

$$\text{gpm required} = \frac{1022}{231} \times 80 = 354$$

$$\text{m}^3/\text{h required} = 16,730 \times 10^{-6} \times 80 \times 60 = 80.3$$

The selected accumulator and pump power plant will be more than sufficient for planishing. As a matter of fact, 100 or even 110 planishing strokes per minute will be feasible.

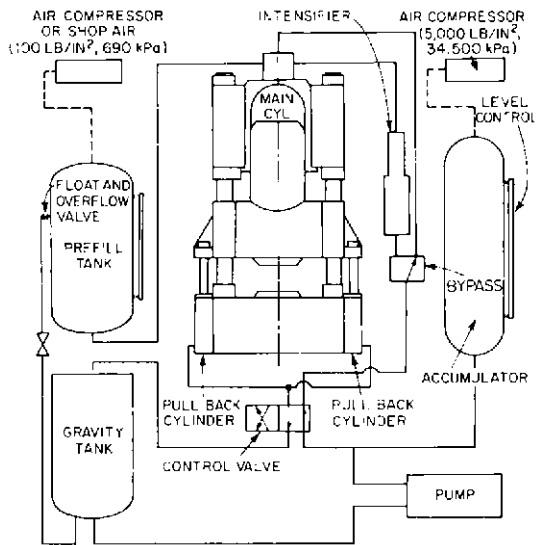


FIGURE 6 Vertical forging press with pull-back cylinders

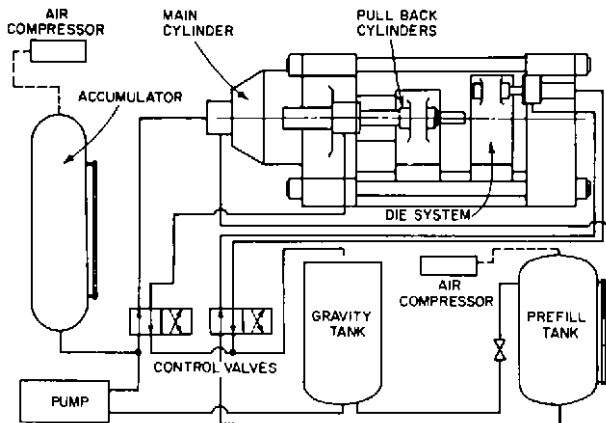


FIGURE 7 Horizontal extrusion press

**INTAKES  
AND  
SUCTION  
PIPING**

---

---

# SECTION 10.1

---

# INTAKES, SUCTION PIPING, AND STRAINERS

---

WILSON L. DORNAUS  
CHARLES C. HEALD

The most critical part of a system involving pumps is the suction approach, or inlet, whether in the form of piping or open pit. A centrifugal pump that lacks proper pressure or flow patterns at its inlet will not respond properly or perform to its maximum capability. Uniformity of flow and flow control to the point of pumped fluid contact with the impeller inlet vanes are the most important. Part of this may be controlled by proper pump design, but the pit designer and suction piping designer have definite responsibilities to achieve satisfactory pump operation. In open suction pit (wet-well) designs, the fluid flow must be as uniform as possible right up to contact with the pump suction bell or suction pipe, preferably without a change in direction or velocity.

Examples of dry-pit and wet-pit centrifugal pumps connected to open suction pits are shown in Figure 1.

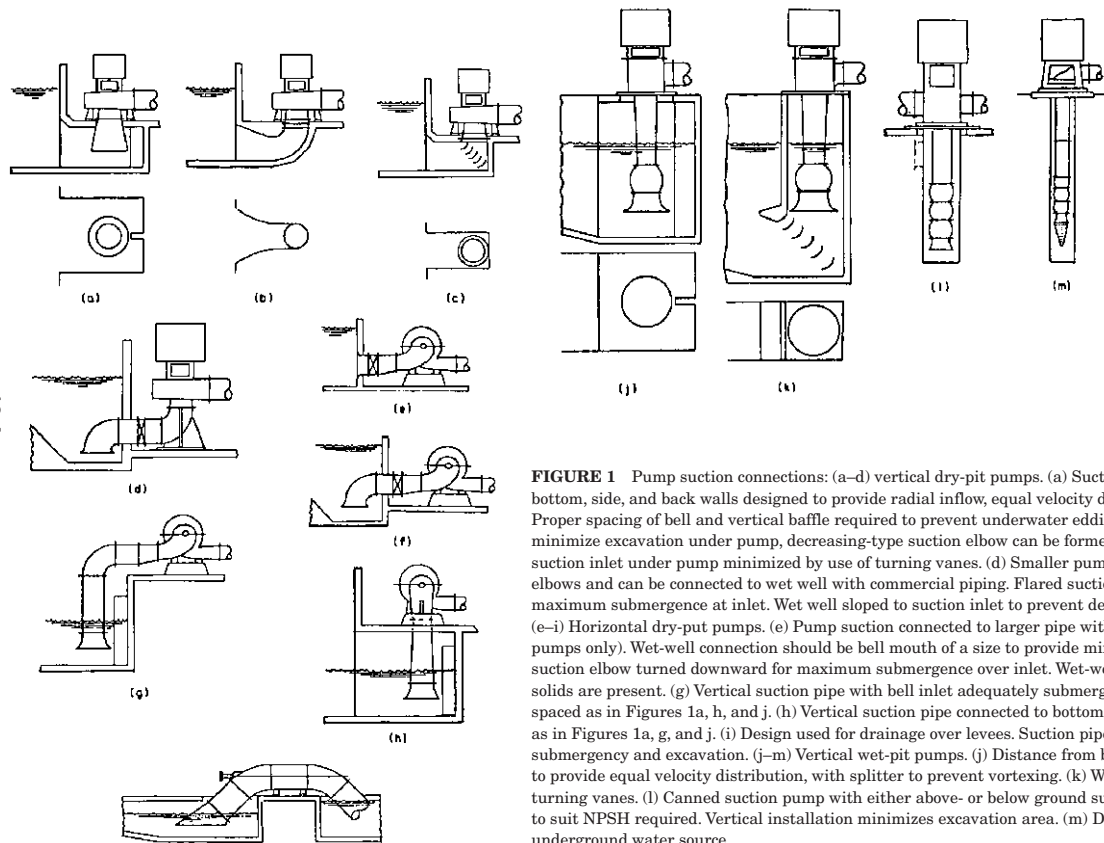
In dry-pit pumping, the pipe leading to the pump suction flange should not include elbows close to the pump in any plane. Also, any other fittings which change flow direction and velocity and which may impart a spinning effect to the flow should be avoided within 8-10 pipe diameters of the pump suction flange. Centrifugal pumps not designed for pre-rotation of the fluid entering the impeller, either dry or wet pit, may suffer loss of efficiency and an increase in noise if a spinning inlet flow occurs. Fluid rotation with the direction of impeller rotation can result in a decrease in pump developed head. Fluid rotation against the direction of impeller rotation can result in an increase in pump developed head and required power, possibly overloading the driver as well as drastically affecting the pump curve shape and performance in the system. If the total system is to operate efficiently and with minimum maintenance, close attention to the suction environment of the pumps is required.

## **INTAKE STRUCTURES**

---

Intake structures can be categorized as being for clear liquids or solids-bearing liquids. For clear liquids, intakes are further classified into rectangular, formed, circular, and





**FIGURE 1** Pump suction connections: (a–d) vertical dry-pit pumps. (a) Suction bell diameter and distance from bottom, side, and back walls designed to provide radial inflow, equal velocity distribution, minimum entrance loss. Proper spacing of bell and vertical baffle required to prevent underwater eddies and rotation at inlet. (b) To minimize excavation under pump, decreasing-type suction elbow can be formed in the foundation. (c) Width of suction inlet under pump minimized by use of turning vanes. (d) Smaller pumps provided with integral suction elbows and can be connected to wet well with commercial piping. Flared suction elbow is turned downward to obtain maximum submergence at inlet. Wet well sloped to suction inlet to prevent deposition of solids. (e–i) Horizontal dry-pit pumps. (e) Pump suction connected to larger pipe with eccentric reducer (double-suction pumps only). Wet-well connection should be bell mouth of a size to provide minimum required velocity. (f) Flared suction elbow turned downward for maximum submergence over inlet. Wet-well floor may be sloped toward inlet if solids are present. (g) Vertical suction pipe with bell inlet adequately submerged to prevent vortexing. Bell sized and spaced as in Figures 1a, h, and j. (h) Vertical suction pipe connected to bottom-suction pump. Bell sized and shaped as in Figures 1a, g, and j. (i) Design used for drainage over levees. Suction pipe designed to require minimum submergency and excavation. (j–m) Vertical wet-pit pumps. (j) Distance from bottom, side, and back walls designed to provide equal velocity distribution, with splitter to prevent vortexing. (k) Width of inlet minimized by use of turning vanes. (l) Canned suction pump with either above- or below ground suction connection. Can length to suit NPSH required. Vertical installation minimizes excavation area. (m) Deep-well pump takes suction from underground water source.

trench types, as well as suction tanks and cans. For solids-bearing liquids, trench-type and rectangular wet wells are usually considered. These structures are covered in detail in American National Standard for Pump Intake Design, ANSI/HI 9.8-1998, Reference 1. Further references to this standard will be contained in this section.

## COOLING WATER PUMP INTAKES

---

**Purpose** Water circulating systems must have either a continuously renewable source, such as an ocean, lake, or river, or they must recirculate the same water from cooling ponds or cooling towers. Regardless of the type of pump selected (wet or dry pit), the suction water will come from an open pit of some sort or from a pressurized pipeline.

### *Types of Intake*

**ONCE-THROUGH: OCEAN, LAKE, OR RIVER SOURCE—WET PIT** Once-through intake structures are usually constructed of concrete and are arranged to gather the water into a localized area for pickup and to support the pumps. The optimum design will bring relatively clear water directly into the pump suction area at a low velocity.

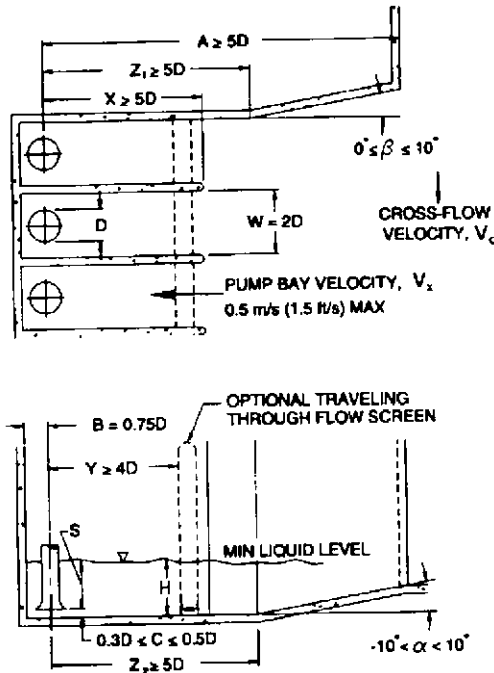
It is recommended that the submergence of the pumps and the dimensions of the suction pit in the immediate vicinity of the pump suction inlet be as suggested by the pump manufacturer. Preliminary intake drawings, however, must usually be prepared for making studies and estimates and for writing specifications for equipment. During this preliminary stage of intake design for vertical wet pit pumps (or for dry-pit pumps having vertical suction pipe with a bell-mouth entrance), the recommendations found in the American National Standard for Pump Intake Design, ANSI/HI 9.9-1998 (Reference 1) should be followed. Figures 2 and 3 show the basic layout of the pumps and intake structure. Geometry is generally defined in terms of the pump inlet bell diameter, as shown. Once the number and size of pumps required is determined, a pump inlet bell diameter can be estimated. At this point, the bell diameter can be estimated based on an inlet pipe velocity of between 3 and 8 ft/s (0.9 and 2.4 m/s). The resulting pipe diameter can then be converted to a corresponding bell diameter approximately 1.5–2.0 times the inside pipe diameter. With the bell diameter selected, the proportions of the inlet structure can be estimated from Figures 2 and 3. Table 1 gives recommended values for the dimensions. For establishing velocities, the minimum submergence over the suction bell for vertical wet-pit pumps can be estimated from Figure 4, based on maximum expected flow rate.

Once the intake pump manufacturer has been selected, final intake dimensions can be established on the basis of actual pump inlet pipe dimensions and the equipment supplier's recommendations. Should there be an appreciable variation in any of the dimensions from various sources, a model test of the intake structure is justified and recommended.

For further guidance, ANSI/HI 9.8-1998 (Reference 1) provides intake design recommendations for both suction pipes and all types of wet pits that are a result of the combined efforts of sump designers, hydraulic researchers, pump manufacturers, and end users. It is intended to provide designers, owners, and users of pumping facilities a foundation upon which to develop functional and economical pumping facility designs.

The intake design process is intended to arrive at a cross-sectional area such that straight-line flow to the bell area is at an average velocity of 1 ft/s (0.3 m/s) or less. This assumes the source to be either a lake or a river with a maximum velocity of 2 ft/s (0.6 m/s). For higher velocities, correspondingly greater distances should be used to the trash rack or screen. The choice of providing a trash rack or screen, or both, is based on the type and amount of debris likely to be encountered at the inlet.

An ocean inlet has additional requirements because of tidal action and variable direction currents which may exist. For these situations, it may be necessary to create a forebay inlet basin. Such a basin would be independent of the pump pit and fed by a submerged inlet tube extending out into the ocean for some distance (Figure 5). This tube may utilize normal pipe velocities, but the inlet must turn upward and the opening should be protected by a horizontal cap to allow the water to travel horizontally at a velocity high enough to scare



**FIGURE 2** Recommended intake structure layout (American National Standard for Pump Intake Design, ANSI/HI 9.8-1998, Reference 1)

fish away. The discharge into the forebay can be pipe velocity because the turbulence will be dissipated by lower outlet velocities [2 ft/s (0.6 m/s)] through trash racks and traveling screens. From this point on to the pump chamber, the velocity should be low and constant.

Any necessary change in inlet channel dimensions should be made gradually. Tapering walls should not diverge at more than a 14 degree included angle. If it is necessary to slope the floor, a maximum of 7 degrees is recommended and, if possible, the floor should level off before reaching the pump area, as far back as possible. No sharp drops (waterfall effect) should be permitted.

If the inlet channel is a closed pipe with full-wetted perimeter, pipe velocities can be used up to a distance from the pump chamber where the tapered wall rule can be applied. This means that the pipe size would be increased in accordance with the rules for maximum taper rate to ensure that the velocity as it discharges into the pump chamber is not over 1.5 ft/s (0.46 m/s). Unless the inlet velocity into the pump chamber is kept below 1.5 ft/s (0.46 m/s), extensive baffling and additional space will be necessary, and this can only be effectively determined by model testing of the pit.

**RECIRCULATING SYSTEM—COOLING TOWER** For cooling tower systems, the pump pit is normally adjacent to the tower basin. Cooling tower basins are shallow, usually not more than 6 ft (1.8 m) water depth. Because pumps will require more submergence than this, a sloping ramp or sharp drop-off will be required if pumps are to be placed close to the basin. This will save initial costs for excavation and concrete work, but the resulting poor flow patterns conditions will cause endless pump problems.

Some successful small installations have been built with downslopes of 15 degrees or more, but tower basin outlet velocity has been no more than 2 ft/s (0.6 m/s) and the downslope widened as it approaches the pump pit. For low flows, low velocities, and fortunate

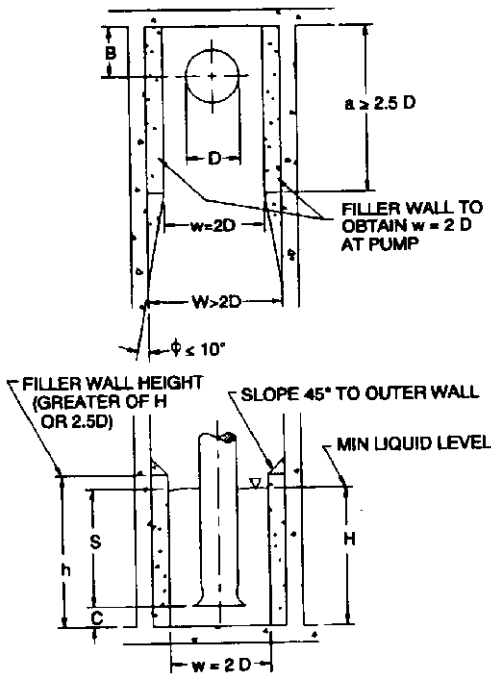


FIGURE 3 Filler wall details for proper bay width (American National Standard for Pump Intake Design, ANSI/HI 9.8-1998, Reference 1)

arrangements of tower piers (lack of recirculation piping, and so on), such installations may be operated with reasonable success. Others of similar design, however, have proven to have disastrous effects on pump performance. Impellers and bearings may suffer rapid deterioration under such conditions.

The best solution, but obviously the most expensive solution, is to build the pump pit far enough from the tower basin to obtain a flat channel bottom. The channel should have an average channel velocity of 1 ft/s (0.3 m/s) or less for a distance at least equal to A in Figure 2, whether trash racks and screens are available. The slope from the basin floor to the channel bottom should not be more than 10 degrees, preferably less than 7 degrees. The basin exit width should be such as to make the exit velocity less than 2.5 ft/s (0.75 m/s). If several tower piers are in the exit path, this velocity limit should be reduced to 2 ft/s (0.6 m/s) or less. Upstream sides of the piers should be rounded off and the downstream sides should be tapered. Make the sidewalls of the downslope diverging so the velocity at the bottom is no more than 1 ft/s (0.3 m/s).

Velocities should be based on the runout flow of one pump. All dimensions and velocities mentioned are limits. If they are used based on maximum required flow rate, and the pump is selected for reasonable velocities, operation should be satisfactory. Obviously, if a pump with high velocities (suction bell inlet, impeller eye, rotative speed) is selected, it will require more submergence than a more conservatively designed machine. This will increase the cost by requiring a deeper pump pit located further away from the tower basin in order to perform satisfactorily.

A model test of the inlet structure is highly recommended if the best solution seems too expensive, or if topography will not allow the ideal arrangement. A model with a variable slope, variable sidewalls, and true representation of piers, pipes, and other obstructions should enable a satisfactory design to be achieved with a possible net reduction in overall

**TABLE 1** Recommended dimensions for Figures 2 and 3 (American National Standard for Pump Intake Design, ANSI/HI 9.8-1998, Reference 1)

Dimension Variable	Description	Recommended Value
A	Distance from the pump inlet bell centerline to the intake structure entrance	A = 5D minimum, assuming no significant cross-flow <sup>a</sup> at the entrance of the intake structure
a	Length of constricted bay section near the pump inlet	a = 2.5D minimum
B	Distance from the back wall to the pump inlet bell centerline	B = 0.75D
C	Distance between the inlet bell and floor	C = 0.3D to 0.5 D
D	Inlet bell design outside diameter	(see text)
H	Minimum liquid depth	H = S + C
h	Minimum height of constricted bay section near the pump inlet bell	h = (greater of H or 2.5D)
S	Minimum pump inlet bell submergence	S = D (1.0 + 2.3 F <sub>D</sub> )
W	Pump inlet bay entrance width	W = 2D minimum
w	Constricted bay width near the pump inlet bell	w = 2D
X	Pump inlet bay length	X = 5D minimum, assuming no significant cross-flow at the entrance to the intake structure
Y	Distance from pump inlet bell centerline to the through-flow traveling screen	Y = 4D minimum. Dual-flow screens require a model study
Z <sub>1</sub>	Distance from pump inlet bell centerline to diverging walls	Z <sub>1</sub> = 6D minimum, assuming no significant cross-flow <sup>a</sup> at the entrance to the intake structure
Z <sub>2</sub>	Distance from inlet bell centerline to sloping floor	Z <sub>2</sub> = 5D minimum
α	Angle of floor slope	α = -10 to +10 degrees
β	Angle of wall convergence	β = 0 to +10 degrees (Negative values of β, if used, require flow distribution devices developed through a physical model study)
φ	Angle of convergence from constricted area to bay walls	φ = 10 degree maximum

<sup>a</sup>Cross-flow is considered significant when  $V_c > 0.5 V_x$  average

cost. Actual pumps and valves should be used to create the flow in the pump pit, and extremes of flow and submergence should be included in the test program.

Sometimes the cooling towers are on a hill, so a substantial drop in elevation provides pressure available nearer the flow area. If dry-pit pumps are used, this pressure can be utilized to reduce pump requirements. When this is done, the pump suction becomes a pipe, and the latter part of this section should be consulted.

**RECIRCULATING SYSTEM—POND WET PIT** The intake structure in a cooling pond should be located as far as possible from the inlet pipe to the pond to generate the maximum cooling effect. If spray surface equipment is used, it should be so arranged in relation to the intake building that a minimum surface disturbance is encountered. Prevailing winds should be considered, and the building should be located on the lee (upwind) side of the

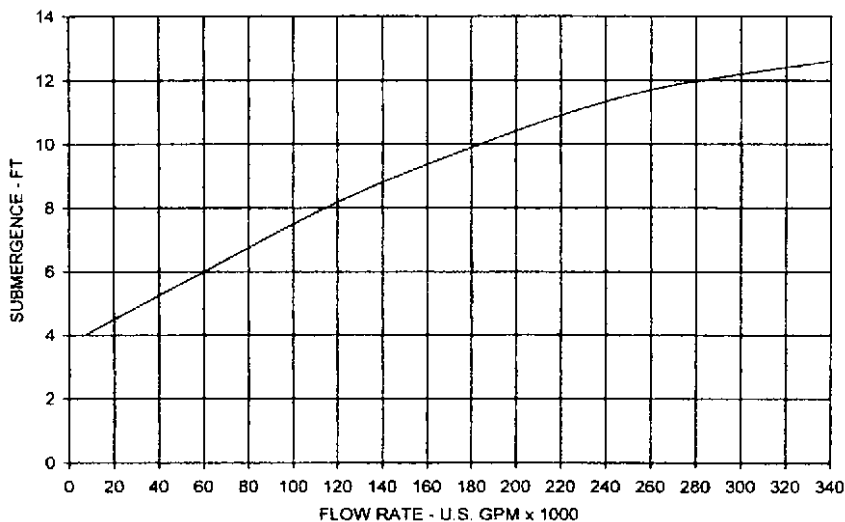


FIGURE 4 Flow rate vs. submergence over suction bell for vertical wet pit pumps. (U.S. gpm  $\times$  0.227 = m<sup>3</sup>/h, ft  $\times$  0.305 = m).

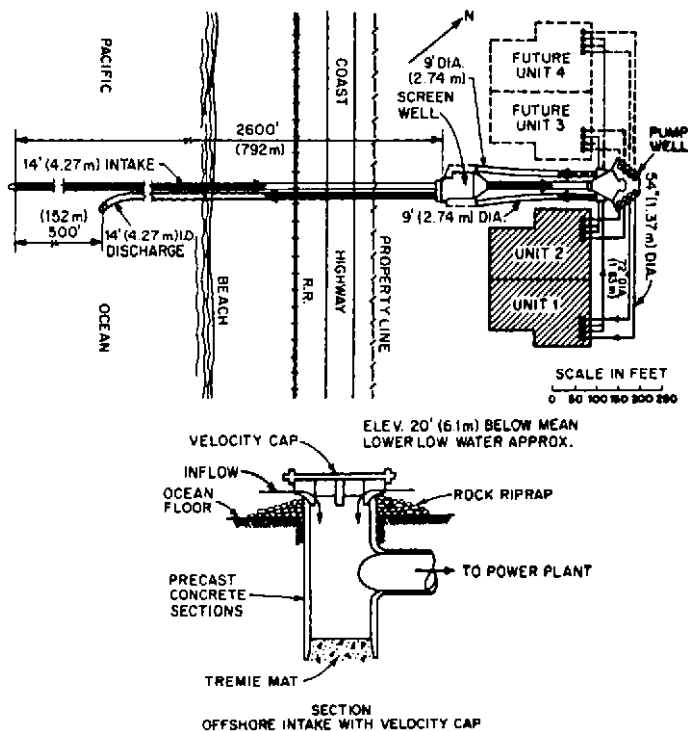
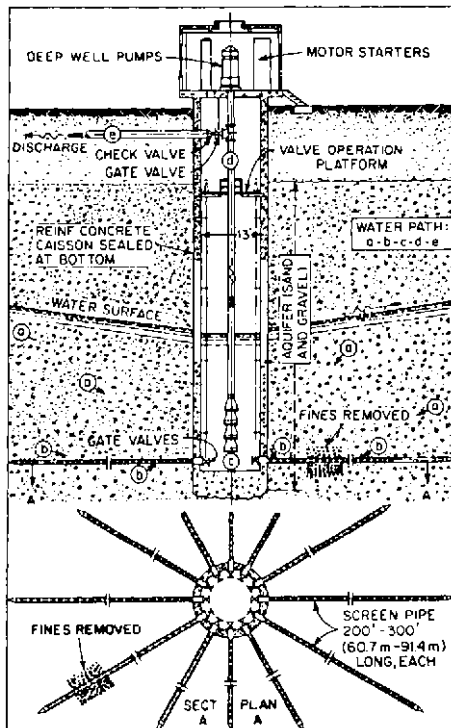


FIGURE 5 Ocean intake with velocity cap to minimize fish pickup

pond. If side and bottom areas might be easily disturbed to include silt in the flow, riprap—a wall or covering of stones thrown together randomly—should be applied to approach slopes as well as to bottom mats well beyond the inlet wing walls.

The handling of silt is usually not desirable in a pumping system. A high velocity through the pump will accelerate wear. At low velocity points in the system, silt will settle out and produce higher velocities, and more wear will occur as a result of the area blockage. If space is available, a silt-settling basin can be constructed ahead of the inlet basin. Cross baffles should be provided to slow the inlet flow to a velocity less than 1 ft/s (0.3 m/s). Most stream debris will settle out at this velocity, and the flow into the pump suction pit will be relatively clean, preventing the deposit of additional silt around the pump suction bell. If space is not available for silt beds in large-capacity installations, the main channel can be furnished with a weir across the flow path. The height of the weir should be selected to give an overflow depth above the weir of not more than one-third to one-fourth the water depth just preceding the weir. The velocity over the crest should not exceed the intake channel velocity. Weirs of this type are particularly effective when the intake channel is at right angles to the supply mainstream.

In areas where river levels vary considerably throughout the year, problems arise not only from silt and debris accumulation, but from the structures required to prevent damage to motors and electrical switch gear. If the required flow is moderate, a system known as the Ranney well (Figure 6) can be constructed. A Ranney well is a concrete silo 13 ft (4 m) in diameter, which becomes the collecting basin and pump well. It may be situated in or near a river and can be partly below and partly above water level with settings up to 100 ft (30 m). Small perforated pipes radiate horizontally from the base of the well and tap



**FIGURE 6** Ranney well collects into a pool from underground strata (Ranney Method Division, Pentron Industries)

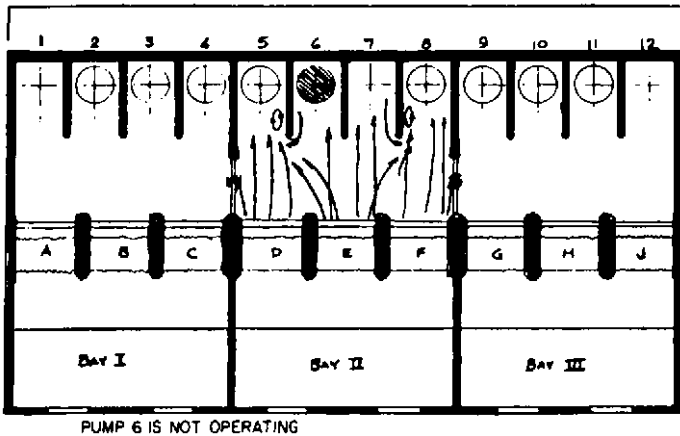


FIGURE 7 Empty spaces on nonoperating pumps cause vortexing at wall ends because of flow reversal.

into porous strata, bringing small flows of water into the main well. This water can then be pumped from the well with a deep-well wet-pit vertical pump.

**Multiple Pumps** Some pump requirements are easily met with 100% capacity single pumps, but more reliability usually requires two 50% or three 33% pumps, or, if the service is sufficiently critical, three 50% or four 33% pumps, and so on. There are practical limits of size for various pump types, so large flow demands will undoubtedly call for a multiple pump arrangement.

The problem arising from multiple pumps arranged in a common pit is from the probable nonuse of some of the pumps while others are operating. This can cause variables in flow patterns that may lead to eddying and vortexing (Figure 7). Installation of separating walls in the common pit may introduce additional problems because the ends of the separating walls can create eddy currents in the corners at the unused pumps. A back vent in the dividing wall will relieve this situation, provided it vents at the water surface (Figure 8b left). If walls are extended past the screens and trash racks to a forebay, this problem will not occur, but the design has then become that of a single-pump basin.

The same velocity rules apply to multiple arrangements as to single-pump basins. Odd arrangements should be avoided even when they look invitingly symmetric—fan-shaped, round, radial, peripheral—all have directional problems that are not easily overcome. A basic pit design, consisting of a number of equally-sized pumps in a common pit basin with flow entering parallel and straight in at 1 ft/s (0.3 m/s) or less, would not need to be model tested to assure reliability (Figure 8a left). If separating walls are required for structural support, and they are properly shaped and vented, no model test is recommended. The pumps should be located at the extreme rear of the pit so the whole approach assumes the characteristics of a suction pipe. Individual pump manufacturers may vary the location of the pump relative to the pit bottom, velocity of inlet spacing, and so on. It has been found that some of these variations require additional splitters or baffles below the pump, up the back wall behind the pump, or centered in the flow ahead of the pump. If so, a model test should be run and the additional pit cost weighed against other alternatives (changing the pit shape, pump location, pump size, and pump speed).

A dry-pit pump installation will have the pumps located either in a dry well at or below wet well water level (Figures 1e and 1f) or directly above the wet well and using a suction lift (Figures 1g and 1h), which calls for priming equipment. The additional cost of priming equipment (vacuum pumps, and so on) may be partially offset by the additional space and valve requirement of the first option. In either case, the suction piping in the wet well



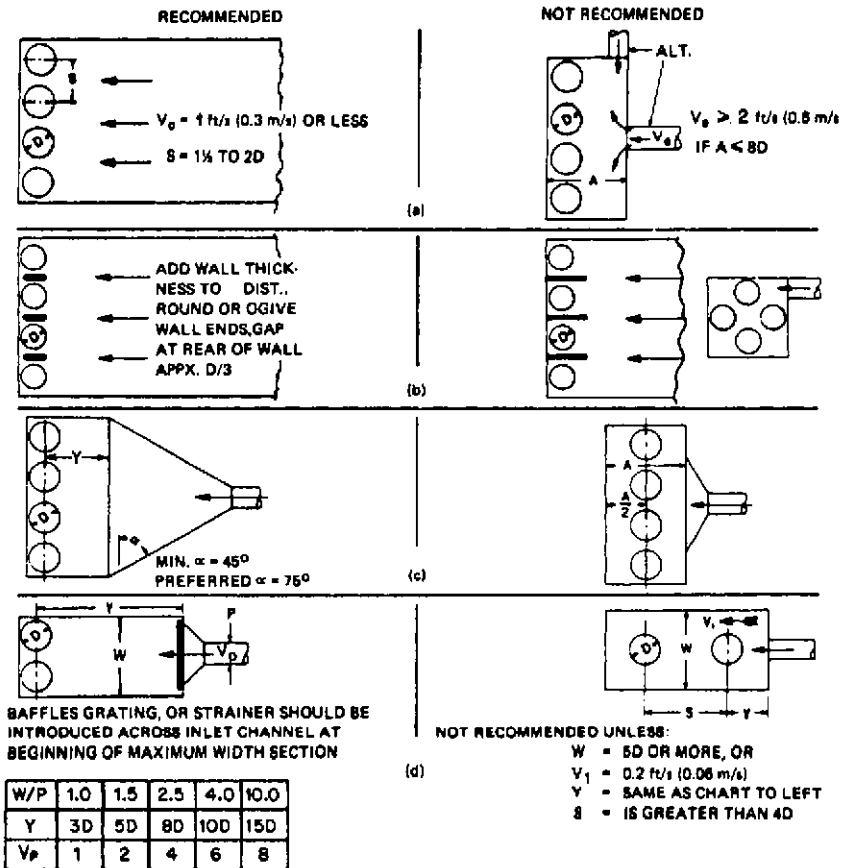


FIGURE 8 Using basics of good pit design precludes the need for model testing (Hydraulic Institute Standards, 13th Edition, 1975—out of print).

should be treated in the same fashion as the pump suction bells in wet-pit installations as far as spacing, direction, and velocity of flow are concerned.

When the pump is installed at an elevation that may be below the water level in the suction pit, a valve must be installed at the suction of the pump. The temptation to reduce the inlet size to use a smaller valve should be avoided. Pipe size at a pump inlet may decrease into the pump down to the pump suction size, but it would not be reduced below that size and then have to increase again as it enters the pump. The pipe in the wet well should preferably have a bell end and project downward. The minimum water level above the top edge of the pipe or the lip of the bell should be at least 5 ft (1.5 m) for a recommended entrance velocity of 5 ft/s (1.5 m/s). The bell mouth should protect downward to assure uniform inlet flow and to attain maximum submergence.

A wet-pit intake style that closely approximates a suction pipe arrangement and uses what is essentially a dry-pit pump has been expanded by the U.S. Department of the Interior, Bureau of Reclamation to an elbow-type suction tube design. This incorporates a formed concrete suction inlet with a swing of 135 degrees in the vertical plane and a gradual decrease in area to the suction eye of the pump (Figure 9). The resulting design saves considerable excavation in the wet well area, reduces losses in the pump,

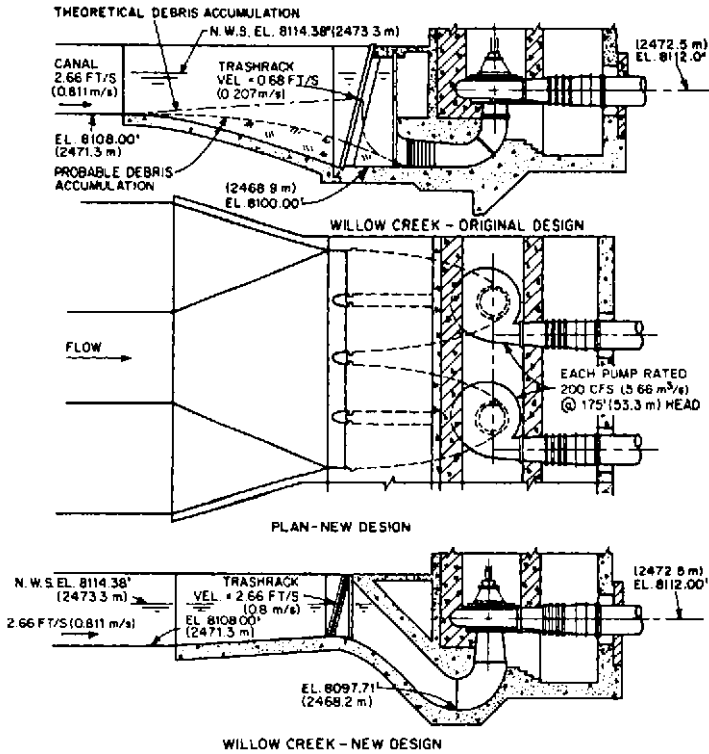


FIGURE 9 Improved 135° design of Bureau of Reclamation elbow suction tube inlet (U.S. Department of the Interior, Bureau of Reclamation)

and allows a smaller, higher-speed pump to be used. With higher velocities, debris dropout is reduced so silt buildup does not occur as readily and a smaller trashrack area remains effective longer. These inlets are independently self-sufficient and may be grouped into multiples as long as the forebay is designed to adhere to the basic design rules for wet-pit approach channels. Additional guidelines on the proportions of formed suction intakes are included in the Hydraulic Institute Pump Intake Design Standard.

Considerations for either single- or multiple-pump pit design relate primarily to even flow and low velocity into the pump. At the leading edge of the pump impeller (suction) vanes, this velocity will be increased and the direction of flow violently changed. To make the transition from pit flow to pump flow is the work of the pump designer. Some pump designs include ribs in the suction bell; others do not. It is obvious that the transition from parallel flow at 1 ft/s (0.3 m/s) to right-angle rotating flow at 15 to 20 ft/s (4.6 to 6.1 m/s) requires a high degree of skill in matching the suction bell to the impeller. If the pump is not designed to handle a wet-pit installation as described in previous paragraphs, a turning vane pit may be required.

**Suction Pit Turning Vanes** Figure 1c illustrates how turning vanes are used to guide the flow of water into the inlet of a vertical volute dry-pit pump. Figure 1k shows the same for the suction bell of a vertical diffuser wet-pit pump. If these pumps were connected to an inlet sump without turning vanes, as illustrated in Figures 1a and 1j, a wider and longer channel would be required to feed the suction bell from all directions. The pumps

with turning vanes narrower inlet channels may be desirable as multiple pumps can be spaced closer together providing screen width requirements do not dictate spacing.

Comparing depth of pit bottom below pumps with and without turning vanes, the following is to be noted. The excavation beneath a vertical volute dry-pit pump with turning vanes can be slightly less than the excavation beneath the same pump with no vanes but with a suction bell. The velocity approach into the closed portion of the channel beneath the pump can be as high as 3 ft/s (0.9 m/s) if turning vanes are used at the design flow; but it should be limited to 1.5 ft/s (0.46 m/s) with no turning vanes. Although the suction bell design requires a wider channel than a vaned inlet (approximately two bell diameters), this is not wide enough and the channel must be made deeper to meet the lower velocity requirement for this type of inlet. When turning vanes are used with a vertical diffuser wet-pit pump, the pit must be excavated deeper than would be required if no vanes were used. This additional depth is required to form an elbow in the narrower channel and provide equal flow distribution to the impeller. Design velocity at the inlet vanes is 3 ft/s (0.9 m/s).

The setting of the lip of the suction bell and the pump impeller below design low-water level for volute dry-pit pumps must be the greater of the dimensions required to

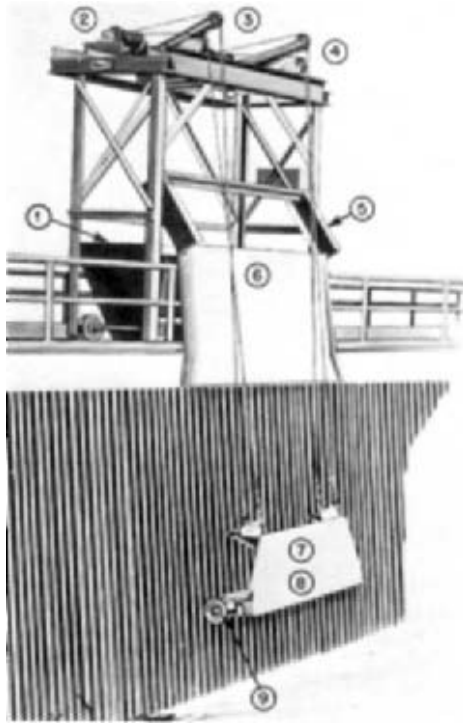
- Prevent vortexing (ANSI/HI dimensions)
- Provide adequate *NPSH* at the centerline of the impeller
- Provide a level of water sufficient for the unit (impeller) to be self-priming

As an alternative to the use of turning vanes under a vertical volute dry-pit pump, the long-radius suction elbow inlet illustrated in Figure 1b offers some advantage in reducing the width and depth of excavation under the pump. The inlet velocity to the long-radius elbow, which is usually formed in concrete, is preferably no greater than 3 ft/s (0.9 m/s) at the design flow rate.

A decision to use turning vanes should not be based on a guarantee that there will be an increase in pump efficiency. The design of the vanes—their number and spacing—is still an art more than a science, and it is difficult to prove pump performance in the field. Turning vanes can be effective in eliminating underwater vortices, a problem sometimes associated with suction bells without turning vanes. It has been observed during model testing that the suction bell, as illustrated in Figure 1a, must be placed closer to the back wall than normally recommended for open channel inlets (similar to that in Figure 1j), to prevent underwater vortexing. The flow of water into a closed channel from an open pit containing water of considerably greater depth creates an unequal flow pattern in which the maximum velocity is along the floor. Also, there is little, if any, flow to the back side of the suction bell down from the top of the channel. Unless the bell lip is close to the back wall, flow along the floor and from the front only will overshoot the inlet and roll over, back, and up into the bell, forming an underwater vortex. Although turning vanes can prevent this, they may not prevent uneven flow distribution up into the pump impeller unless they are properly designed. They may even cause hydraulic and mechanical unbalance, which could result in noise, vibration, and accelerated wear of the pump bearings. For this reason, model testing of the turning vanes is recommended.

**Screens and Trashracks** Although it may not be feasible economically to eliminate all refuse from a pumping system, it probably will be necessary to limit the size and amount of debris or sediment carried into the system. Depending on the probable source of debris, such as a river subject to flooding with considerable flotsam in the runoff and with a very loose bottom, or a lake at constant level without disturbing inlet flows near the structure and with a solid bottom, the protection needed may include only a bar trashrack plus rotating, flushed, fine-mesh screens. If sediment deposit is likely, a settling basin may be required.

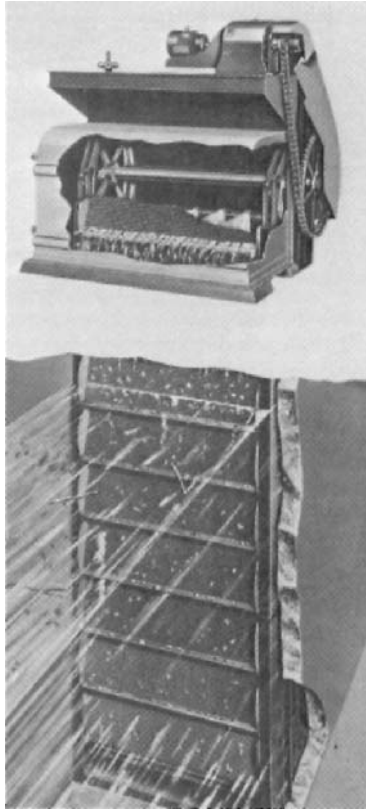
The designer must note that, if this equipment is useful, it will pick up debris and gradually increase the velocity through the openings as the net area decreases with blockage. When this occurs at the trashrack, the water level differential will build up, causing a waterfall with increased velocity and turbulence on the pump side of the rack. In addition,



**FIGURE 10** Trashrack with raking mechanism: (1) Large enclosed trash hopper contains debris discharged by rake. Hinged door in end of hopper opens wide for debris removal. (2) Heavy-duty, single-drum hoist, push-button-controlled with two separate cables—one for carriage, one for rake teeth. (3) Walking beam actuated by hydraulic cylinder controls position of rake teeth. (4) Fixed sheave. Cable operating over stationary sheave raises and lowers rake carriage. (5) Discharge guide flanges assure positive positioning of rake over trash chute prior to dumping. (6) Dead plate, or apron, integral with superstructure guides rake to discharge point—prevents trash from falling off rake prematurely. Design permits operation over 3.5-ft. (1.1 m) high hand rail. (7) Self-centering rack-guided carriages allows rake to ride over obstructions in water during lowering cycle. Debris of all types picked up on lifting cycle rather than forced to bottom of channel. (8) Rake mechanism assures positive removal of debris with maximum carrying capacity. Hydraulic relief valve provides automatic overload relief. Teeth automatically open if overload occurs, permitting load to drop off rake. No cable failures due to overload. (9) Wide, flanged rollers ride on at least two rack bars (Envirex, Inc., a Rexnord Company)

the increase in velocity may pull more debris through the bars than can be tolerated. It is best to rake these racks (Figure 10) frequently enough to keep the differential head across the rack below 6 in (0.15 m). The spacing of the bars should be such that objects that cannot be pumped would be excluded from passing through. This, in general, will call for the bar spacing to be in proportion to the size of the pump. A pump manufacturer can determine the maximum size sphere a pump will handle, and the bar spacing should be limited to 50% of that value. The size of the bar, the lateral distance between supports, and the pier spacing will influence the rate of debris accumulation and the allowable design differential head.

Rotating screens (Figure 11) will remove trash of a much smaller size because the accumulation is continuously removed and the open area is kept uniform. Finer screening than that required by the pump may be necessary in installations where the liquid pumped must pass through small openings in equipment serviced, such as condenser tubes or spray nozzles (Figure 12). Screens are usually installed in conjunction with trashracks so large, heavy pieces will not have to be handled by the screens. Because velocity through

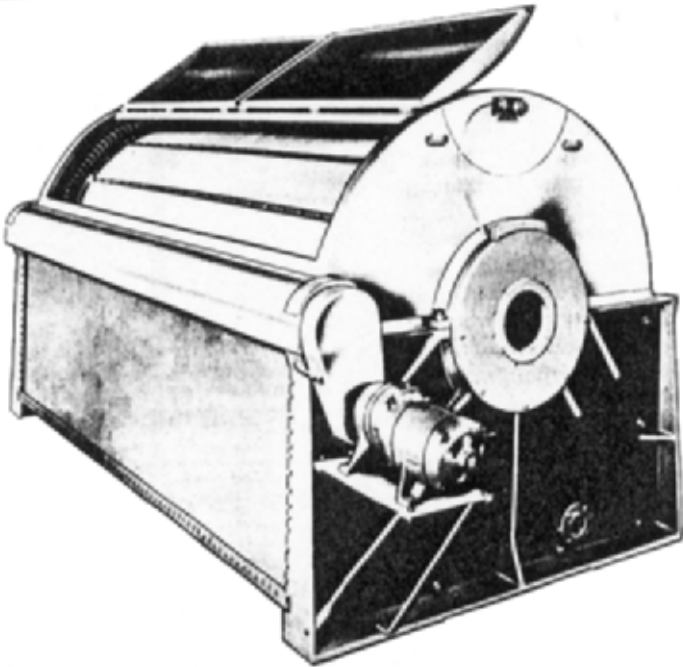


**FIGURE 11** Traveling water screen (Envirex Inc., a Rexnord Company)

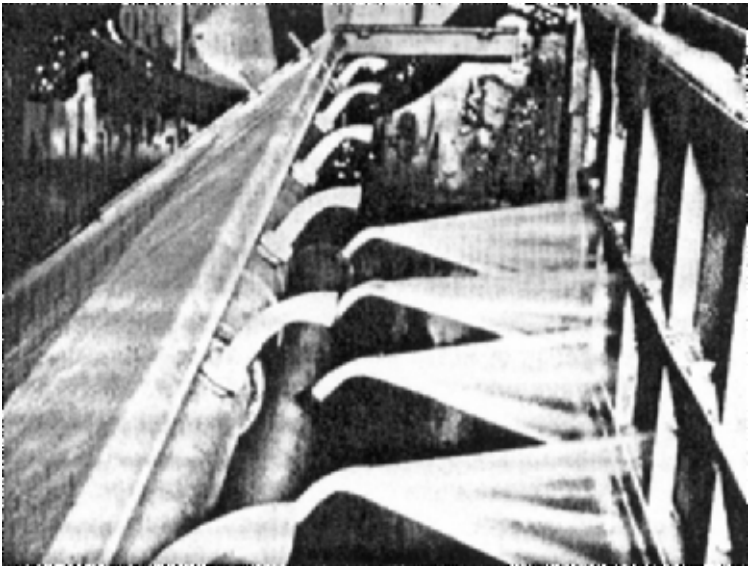
the screen is limited to 2 ft/s (0.6 m/s) unless environmental considerations require lower velocities, the pit cross section may be determined by screen requirements. If flow is such that a maximum-width screen available would be too long (deep) for practical or economic reasons, two screens may be employed with a center pier. In this case, the distance to the pump should be increased 50% over single-screen distance. Piers should be rounded (radiused) on the upstream side and ogived (tapered to a small radius) on the downstream side. Any corners at the sidewalls should be faired at small angles to the opening and wall to prevent pockets where eddies can form.

The trash collected by the screens must be disposed of. Traveling screens carry trash up into a hood above the operating floor, at which point a series of spray nozzles wash the trash into a trough leading into a disposal area (Figure 13). The nozzles are supplied by pumps sized for 200 to 300 gpm (45 to 68 m<sup>3</sup>/h) with pressures of 60 to 100 lb/in<sup>2</sup> (413 to 690 kPa). These pumps are normally deep-well turbine multistage units. They are located in the clear well, if possible, close to a wall. If this is not possible, they can be suspended in the circulating water pit, to one side and ahead of the main pumps. Care must be taken that they do not disturb the flow to the larger pumps. Their submergence requirements are usually less than those of the main pumps, and this allows use of the pump setting that gives the least interference with either pump flow.

It is possible to have these pumps also dewater the pit. This will require additional piping and valves and a more careful location of the pump because it will, of necessity, be close



**FIGURE 12** Drum filter (Green Bay Foundry and Machine Works)



**FIGURE 13** Spray nozzle cleaning of baskets on traveling water screens (Envirex Inc., a Rexnord Company)

to the bottom of the pit. A small chamber off the main pit, located far enough from the main pumps to avoid eddying, will be required.

The direction of the flow from the forebay through the screens and into the pump area should be continuous. Avoid right-angle screens, through which flow must change direction at least once and possibly twice. If screens must be at an angle to the flow into the pumps, increase the screen-to-pump distance by 100%. Environmental considerations may increase the possibility of problems in this area.

**Environmental Considerations** Suction pit requirements will vary according to whether hydraulic or structural standpoints are being considered. Both of these may also be in conflict with environmental considerations.

A design to accommodate fish limitations was mentioned briefly in a previous paragraph. Fish react to a horizontal velocity but are not aware of a pull in a vertical direction. Thus, to keep them from entering the inlet, a horizontal flow must be established at a velocity low enough to permit fish to escape.

Intakes that take their flow directly from a river may have a high velocity that would trap fish. Even if the velocities are lowered to reasonable screen levels—2 ft/s (0.6 m/s)—fish may still be drawn into the screen area and carried up to trash disposal.

When the source of a water supply system is a body of water containing fish, steps must be taken to prevent undue disturbance and destruction of the fish. A site survey should determine

- The intake location furthest from natural feeding areas and from attractive, or “trap,” areas
- The number of species involved
- The size range of each species and whether they are anadromous or settled

Sites for intakes should not be selected near feeding areas for large schools of fish (kelp beds, coral reefs, and similar attractive spots). Sheltered spots most suitable for intake flows may also be most attractive to fish.

Next, total flow, probable intake size, and the velocities at inlet, through screens, and at trashracks should be determined. Variations in flow throughout the year and temperature ranges in winter to summer should be available.

The best source of information about local fish is marine biologists who have studied the local areas. They may not only have information on fish habits, feeding patterns, population, and so on, but may also have test information about the fish swimming ability. If they do not already have this information, they can probably run a survey to develop the data.

The most difficult problem to overcome is related to small fish. Screen openings must be held to a minimum, and under velocity conditions, small fish have much less swimming-sustaining ability than larger fish, both in speed and in duration time. In a given steam flow (such as is generated by pumps with inlet water going through screens), a fish must have the ability to sustain a given speed against this flow for a certain length of time. When it weakens, it will fall into the current flow and will be impaled against the screen and destroyed. If the fish senses the velocity early enough, and has an alternate route, it can use darting speed to escape. Or it can follow another attraction (cross velocity flow into a separate chamber or a light attraction to the chamber) and be removed on an elevator or pumped out to a safety channel (Figure 14). Migrating fish need a continuation channel to restore their interrupted journey.

In designing an intake, it is necessary to keep the velocity below 0.5 ft/s (0.15 m/s) through the screen to avoid drawing fish into the screen. For a tube inlet away from shore, a horizontal *velocity cap* (Figure 5) should be placed over the inlet. This will prevent fish from being subject to a vertical velocity and will allow them to maintain a horizontal velocity that will direct them away from the inlet. Alternatively, a cross flow can be created that will propel or attract the fish to one side of the inlet area. From there, they can be directed into a bypass pool and lifted back to their own living area, or they can be sent around the plant to a downstream location. If they are anadromous, they can be sent to an upstream rendezvous. Piers and screens should be kept flush across their inlet face to prevent attractive pockets where fish can hide and be drawn into the screens when they weaken.



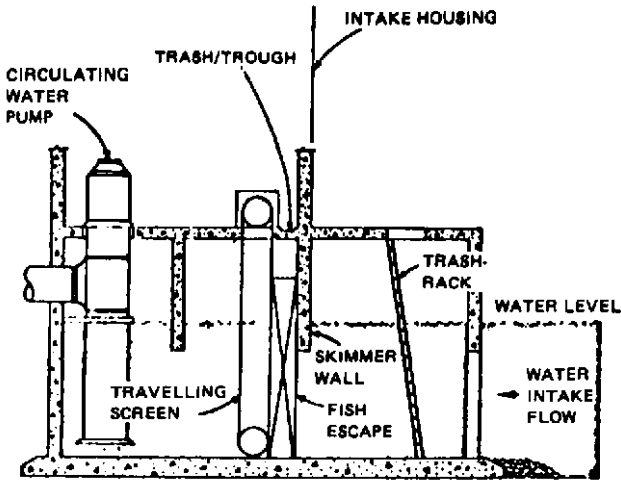
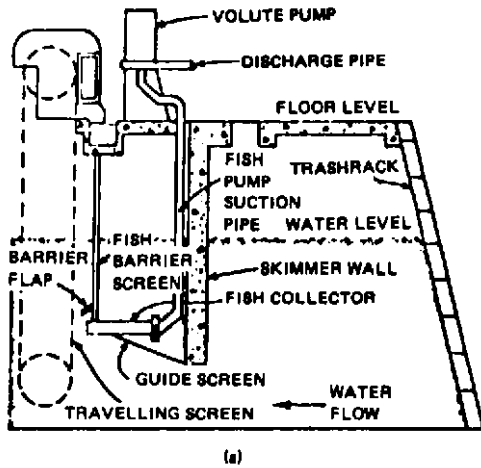


FIGURE 14 (a) Fish pump prevents entrapment on traveling screen (Detroit-Edison). (b) Fish escape allows fish to bypass screen area.

Inlet screen areas should be in small sections rather than one long face so a fish will not be trapped in the center and find it too far to swim to safety after it realizes its predicament. The maximum deterrent flow is about 10 ft/s (3 m/s), but this may be too much disturbance for the flow to the pumps. Smaller areas allow short-term limits for enticing fish away from the inlet, and survival will be much higher.

Fish congregating at an inlet or in a forebay pool can be crowded or herded to an outlet point by the use of vertical nets or horizontal screens. In a direct channel, horizontal moving screens can route fish past a sloping (relative to stream flow, say 35 degrees) moving screen. This results in directing fish to a narrow outlet at one side, leading to an outlet channel away from the main inlet.

The Environmental Protection Agency has had a major impact on plant design since the passage of the Federal Water Control Act of 1972 (as amended) in the US. Enforcement



of Section 316a regarding thermal effluent has softened somewhat as later studies indicate that the effects of heat distribution on marine life are variable. Section 316b, however, covers every aspect of best-known technology and is applicable to any facility using a water intake structure.

Young fish must be kept from impinging on inlet screens. This can be accomplished by

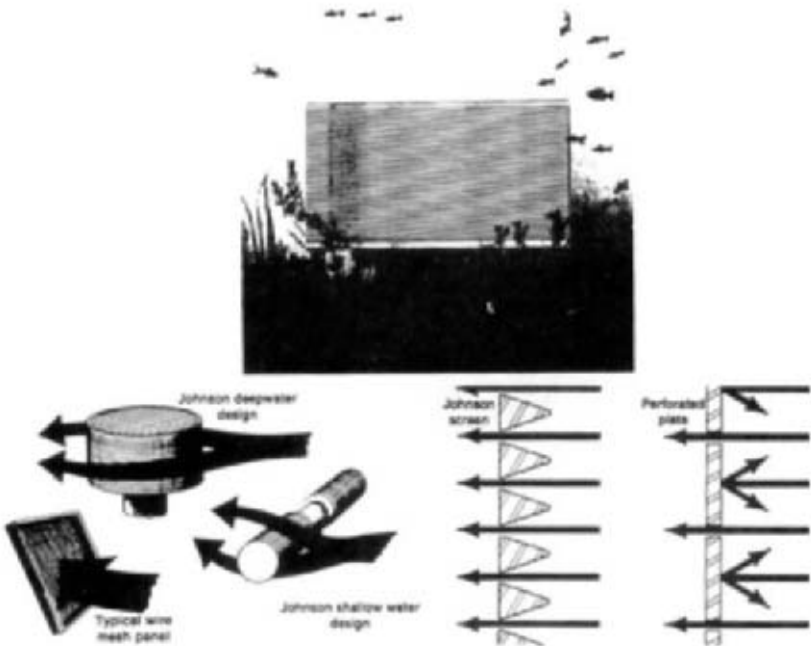
- Lowering the velocity through the inlet screens
- Diverting or attracting the fish to other areas
- Providing restraints at inlets
- Using fish buckets and elevators to remove the fish before they can enter the plant area
- In short, by helping the fish avoid contact with the intake to the greatest extent possible

Obviously, trash and fish must be handled in separate areas, and screen wash pressures must be lowered to prevent harm to the fish.

Entrainment of marine organisms too small to be restrained by normal screens causes further problems in areas where such organisms normally develop. If the intake structure must be located in such an area, extensive information must be gathered at the site. Analyzing as much data as are available, in conjunction with plant flow and location requirements, may give the designer some idea of which equipment to select.

Small slot-width wedgewire screens (Figure 15) are now being furnished in larger sizes, and, with their very low inlet velocity and backflushing capability, offer one good approach to reducing entrainment. Sand, chemical, and cloth filters may suit some situations, but backflushing and cleaning problems make them less attractive costwise.

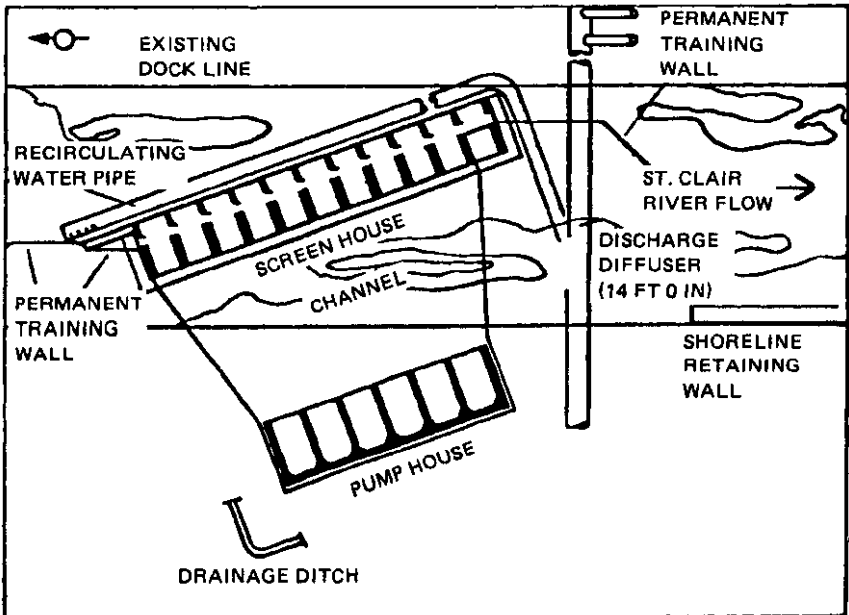
Equipment may consist of any combinations of



**FIGURE 15** V-shaped slotted screen provides velocity control to avoid attracting fish and good air or water backflushing for debris cleanup (Johnson Division, UOP).

1. Stationary screens
  - a. Bar racks in various attitudes (Figure 10), with or without automatic rakes
  - b. Air bubble, lighting, or electric heaters
  - c. Underground, as in Ranney wells (Figure 6)
2. Moving screens
  - a. Vertical or horizontal (Figure 11)
  - b. Drum (Figure 12)
3. Transportation devices
  - a. Elevators
  - b. Pumps (Figure 14)
  - c. Baskets on vertical screens
  - d. Attractive escape areas (Figure 15)
  - e. Velocity changes
4. Remote intakes
  - a. Ocean outfall with velocity cap (Figure 5)
  - b. Ranney well (Figure 6)

If the source is a river, the angle of the intake structure relative to the direction of flow is important in modifying the impact of these design requirements. A case in point is shown in Figure 16. The screen house at a low angle to the river flow (instead of the usual 90 degree inlet) allows the river current to provide a swim-by attitude for fish while a low-velocity screen approach is maintained. If the pump house is in line with the screen house,



**FIGURE 16** Angling the intake structure to the river flow allows fish to swim by Belle River power plant (Detroit-Edison)

minimal disturbance will be felt by the pumps. A tendency for eddies to form (and create vortices) can be minimized by placing wing walls upstream and downstream to control velocity.

**Testing Model Pit Design** When the basic rules for good pump suction pit design are adhered to, no model test will be required to ensure proper operation of the pumps and pumping system. The substance of these rules is to keep a straight-in approach at a constant low velocity from the water source to the pump chamber. The ANSI/Hydraulic Institute Standard dimensions and charts satisfy these criteria for the average pump in general application.

Site layout problems may make the ideal solution impossible. Structural and environmental requirements may outweigh hydraulic requirements in some instances. When the ideal pit may not be possible or economically feasible, a model test should be considered. It should be noted that the ideal dimensions are a composite covering not only a range of specific speeds but also a complex melding of pump design philosophies. Some variation from ideal dimensions should be expected from individual pump manufacturers.

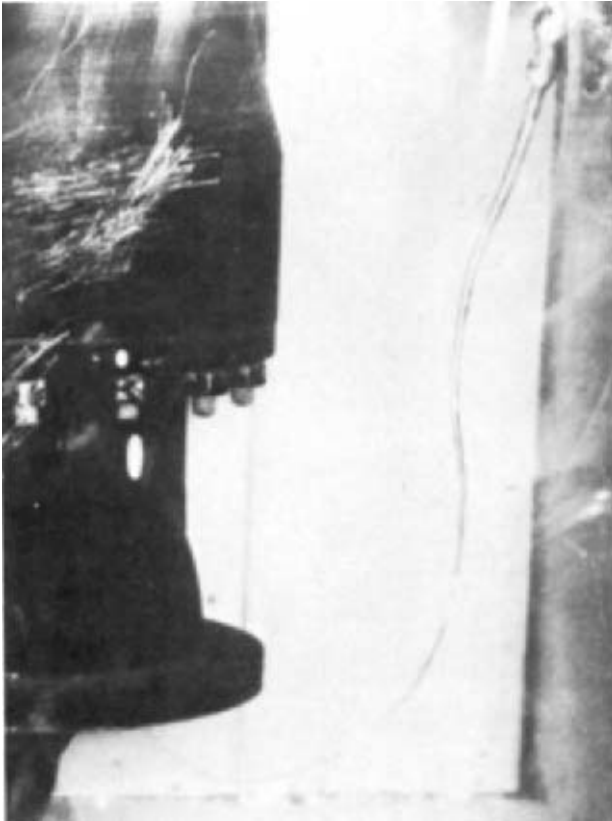
Pump manufacturers are not in a position to guarantee the pump pit design. Differences of opinion between the structural and hydraulic pit design engineers and the pump design engineers may best be resolved by performing a model pit test (Figure 17). Refer also to Section 10.2.

**Vortexing** The real problems resulting from improper pit design occur largely on the water surface in the form of vortices, or cones, produced by localized eddies on the surface of the water. If this disturbance continues, the flow of water will carry the underwater part of the vortex down toward the pump suction bell and ultimately into the pump (Figure 18). This introduces air into the impeller and will affect the mechanical radial balance of the impeller by interrupting the normal solid-liquid flow pattern. This type of disturbance will produce hydraulic pulsations in the pump flow and mechanical overloading of bearings and impeller guides.

Underwater vortexing sometimes occurs in round pits or in pits where the pump suction bell is at some distance from the rear wall. Flow past the suction bell strikes the rear



**FIGURE 17** Model pit test setup with fixed screens and pumps and valves for variable flow, to scale (Flowsolve Corporation)



**FIGURE 18** Surface vortex drawing air into pump suction bell

wall and rolls back toward the bell, forming an eddy current that disturbs the normal flow into the pump. In a round pit, a cross baffle below the pump bell may reduce this effect. Where the pump is some distance from the back wall, a wall can be installed near the pump, or a horizontal baffle at suction bell level behind the pump will also reduce the disturbance. In all cases, the distance between the suction bell and the bottom of the pit should not be more than one-half the suction bell diameter, and one-third the diameter is preferable.

The use of the suction bell diameter as a basis for spacing should be carefully evaluated. It will be seen that there is nothing magical in this relationship, especially when several pump manufacturers all use different bell diameters. The real criterion is the allowable velocity at the suction bell. It has been found that very-low-head pumps are much more sensitive to bell velocity over 6 ft/s (1.8 m/s). For example, the velocity head loss at the bell inlet with a high velocity may be such a large percentage of total pump head that efficiency could drop as much as 10%. A good design rule for safe operation can be related to pump head. For pumps having up to a 15-ft (4.6-m) head, the suction bell velocity should be held to 2.5 ft/s (0.76 m/s); up to 50-ft (15-m) head, 4 ft/s (1.2 m/s); and above 50-ft (15-m) head, 5.5 ft/s (1.7 m/s). These values should be used for any substantial amount of pumping, but for occasional short-term pumping, they can be exceeded without destroying the pump.

Vortices may be broken up and effectually nullified by arrangements of baffles and vanes, or they may be prevented from occurring initially by a proper pit design. The only

way to determine what type of baffling should be used and its effectiveness is by model testing. Methods of eliminating vortexing are discussed in Section 10.2.

Vortices are usually generated when the flow direction of the liquid to be pumped changes or when there is high velocity past an obstruction, such as a gate inlet corner, screen pier, or dividing wall. In combination, these two causes invariably generate vortices. For this reason, the pump suction pit should be immediately preceded by a straight channel in which the velocity does not exceed 1.25 ft/s (0.4 m/s). Satisfactorily operating pump pits with higher velocities are rare and should not be put into operation without the assurance of a model study.

An additional condition likely to generate vortices is a multiple pump pit with individual cells in which only a portion of the pumps will operate simultaneously. The dead space behind the non-operating pump will have flowing water tending to reverse direction and form eddies. Eddies and vortices can be avoided by eliminating or venting the walls at the rear of the pit. It also helps to position the pumps at the extreme rear of the pit. Alternatively, expensive modifications to the pit, such as splitter walls and baffles, may be required (Figure 7).

Round pits tend to generate vortices, especially when the pump is centered in the pit. These vortices usually occur around the pump column because of eccentric inlet flow. Special cases of the round pit are tolerable either when a Ranney well (Figure 6) is used or when there are booster pumps in the pipelines (Figure 19). In the Ranney well, the ratio of pump size (and flow) to pit size (and capacity) is such that very low velocity exists, as in a lake inlet. Water comes into the Ranney well all around the periphery. These conditions of direct flow and low velocity prevent vortexing. Booster pumps installed in a circular can



**FIGURE 19** Booster pump suspended in a steel well (or can) that requires a minimum space for suction pit (Flowsolve Corporation)

(suction tank) must be centered in the can, and all inlet velocities to the can and flow in the can and into the pump must be uniform and high enough to provide fluid control. This velocity will vary from 4 to 6.5 ft/s (0.76 to 1.98 m/s).

Vortices are not generated by a pump or pump impeller and so do not fall into clockwise or counterclockwise rotation because of the pump rotation. Also, in a pump pit, vortices do not have a directional rotation induced by the rotation of the earth and therefore are not of opposite rotations above and below the equator, as is the case with "bathtub vortexing," which occurs in tanks being drained without pumps.

**Submergence** Centrifugal pumps in intake pumps must be submerged deeply enough to provide

- A pressure sufficient to prevent cavitation in pump first-stage impellers, referred to as *NPSH* (it is assumed that the proper pump has been selected to perform satisfactorily with available *NPSH*)
- Prevention of vortexing and associated pit flow problems detrimental to pump operation

A pump may have adequate submergence from a pressure standpoint and still be lacking in sufficient depth of cover above the suction inlet to prevent surface air from being drawn in. Any wet-pit pump must have its suction inlet submerged at all times, and for continuous pumping every pump will have a fixed minimum submergence requirement. Because this relates to velocity, there are two basic parameters: the suction inlet diameter and the depth of water above the inlet lip. As pump size (and flow) increase, the inlet velocity may stay constant as the bell diameter increases, but at the same time, the impeller distance above the suction inlet becomes larger, so a fixed submergence value would lead to increased surface velocity, peripheral drawdown, and an increase in air intake.

Basically, submergence must of necessity increase with pump size. For the final determination, some balance must be struck between submergence and pit width to satisfy an average flow velocity of 1 to 1.25 ft/s (0.3 to 0.4 m/s) and maintain reasonable economic balance between excavation costs, concrete costs, and screen costs without neglecting ecological requirements and still fulfilling the primary need for circulating water in adequate quantities.

## SUCTION TANKS

There are a variety of shapes and configurations for suction tanks. They may be vertical or horizontal, cylindrical, or rectangular. Outlets from the tanks may be vertically downward, horizontal, from either the side or bottom of the tank, or in the case of a pressurized tank, vertically upward. The formation of vortices in the tank can cause air or gas entrapment even when the tank outlet is fully submerged. This can cause pulsating pump flow, noisy operation or a reduction in pump performance.

To determine minimum submergence of the outlet pipe in the tank, the Hydraulic Institute recommends the following relationship:

$$S/D = 1.0 + 2.3F_D,$$

where  $F_D$  = Froude number =  $V/(gD)^{0.5}$

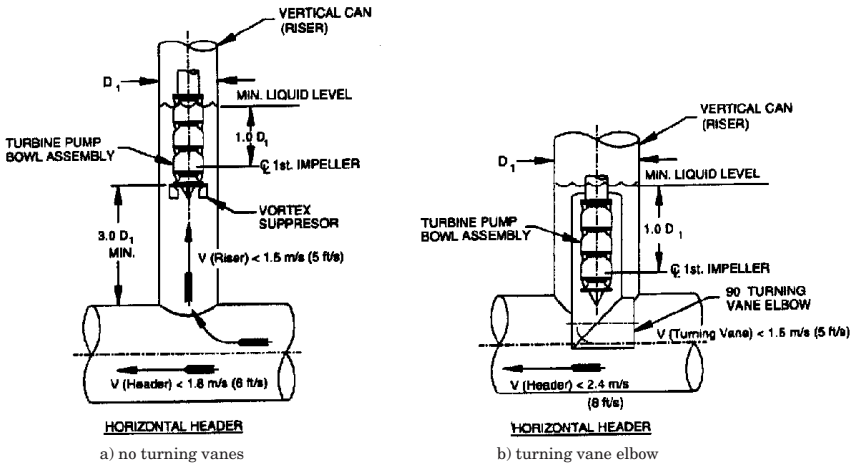
$D$  = outlet fitting diameter, ft (m)

$S$  = submergence, ft (m)

$V$  = outlet fitting velocity, ft/s (m/s)

$g$  = acceleration of gravity, ft/s<sup>2</sup> (m/s<sup>2</sup>)

Figure 20 shows examples of how to apply the calculated submergence value depending on tank orientation and outlet configuration. Figure 21 shows how to use the above equation to calculate velocity for the Froude number calculation, depending on type of



**FIGURE 20** Open bottom can intakes for pumps less than 5000 gpm (315 l/s) (American National Standard for Pump Intake Design, ANSI/HI 9.8-1998, Reference 1)

outlet fitting and direction of tank outlet flow and nozzles. If the tank has multiple inlets or outlets, the design should be such that flow interaction is not detrimental to overall performance.

### CAN PUMP INTAKES

A can pump is defined as one that has a can, or barrel, surrounding the pumping unit. This can acts as a "sump" or intake structure for the pump suction impeller. The can may be either closed bottom, and contain the pump suction nozzle, or open bottom and connect directly to a piping header. The can design must provide uniform, stable flow distribution to the suction impeller inlet.

Vertical turbine pumps (Figure 19) require uniform inflow to the suction bell to avoid swirling and submerged vortices that may result in cavitation, vibration, and accelerated pump wear. When a pump with an open bottom can design is connected to a horizontal header (Figure 20a), the velocity in the header should be no more than 6 ft/s (1.8 m/s) to allow the liquid to turn and flow upward to the pump suction bell. The velocity in the can rising to the pump should not exceed 5 ft/s (1.5 m/s), and the suction bell inlet should be located at least three diameters above the top of the horizontal header. For velocities approaching the maximum recommended levels, vortex-suppressing vanes may be added to the suction bell area to break up swirling and nonsymmetrical flow patterns as they approach the impeller inlet.

If a 90 degree turning vane elbow on the can assembly surrounding the pumping element is used (Figure 20b), the velocity in the horizontal header can be as high as 8 ft/s (2.4 m/s). The turning vane elbow should be sized for a maximum velocity of 5 ft/s (1.5 m/s).

Most can pumps are of the closed bottom design (Figure 21). In this arrangement, the pump suction nozzle is located either in the can or in the pump nozzle head that contains both the suction and discharge nozzles. The pumping element (assembly) must be centered in the can to avoid non-uniform flow to the suction impeller. Flow straightening vanes are suggested for all can intakes. Because of the limited volume of liquid in the can, surging of the liquid level within the can—or barrel—cannot be tolerated; the can should be

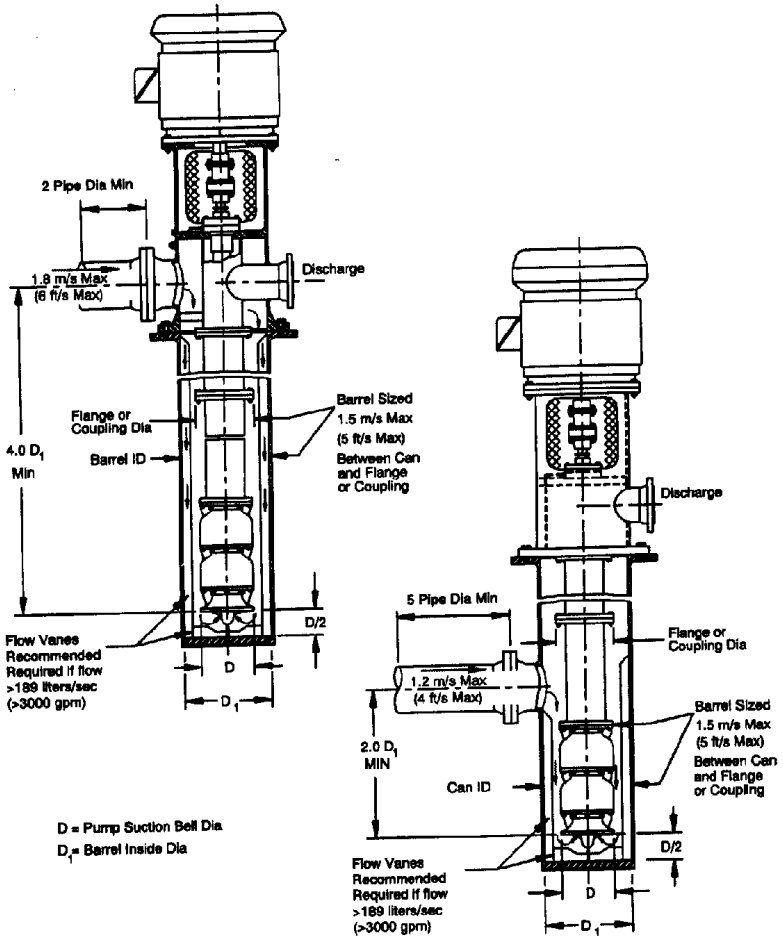


FIGURE 21 Closed bottom can (American National Standard for Pump Intake Design, ANSI/HI 9.8-1998, Reference 1)

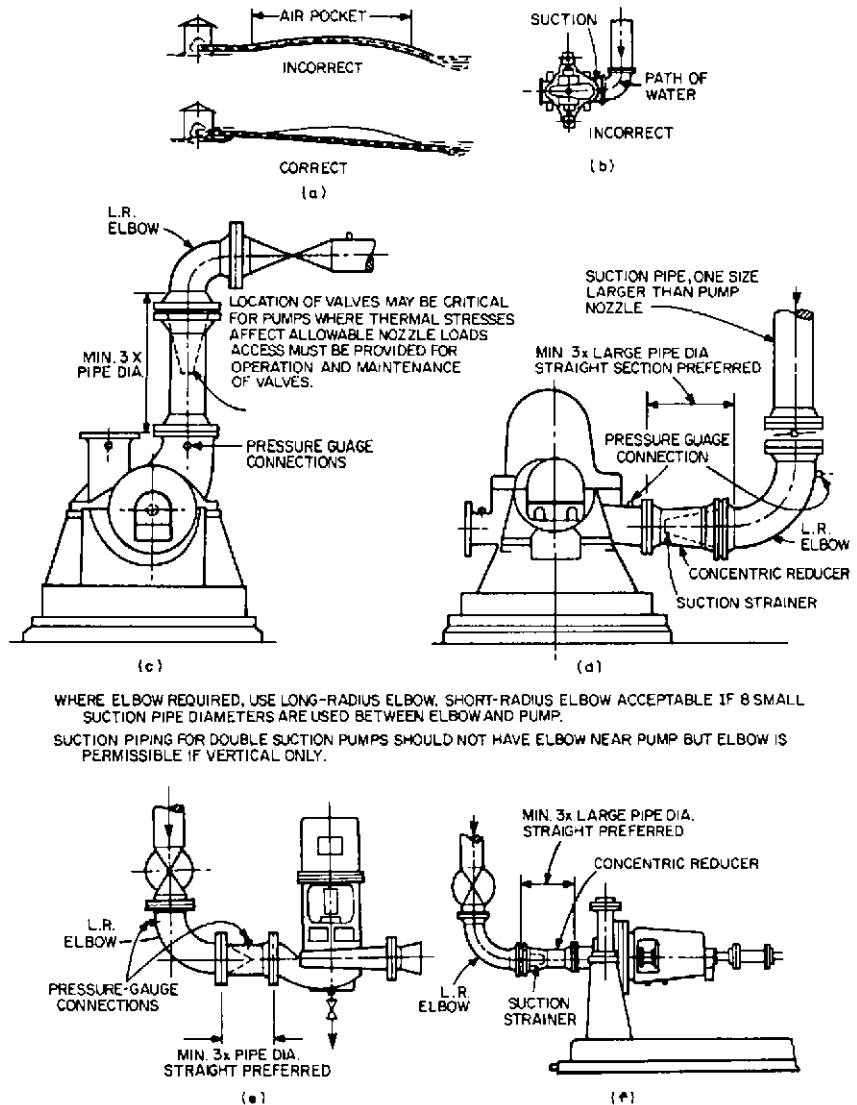
arranged so it is always full. The velocity of the flow between the pumping element and the inside of the can should not exceed 5 ft/s (1.5 m/s). For a suction nozzle velocity of 4 ft/s (1.2 m/s) maximum, the centerline of the nozzle should be at least two diameters above the suction bell inlet. To ensure uniform flow distribution into the can, the suction nozzle should be connected to at least five pipe diameters of straight pipe before elbows or other flow-disturbing fittings are installed.

Pumps with submersible well-type motors require flow around the motor for cooling. A shroud is typically used to direct flow across the motor as it goes into the pump. The top of such a cooling shroud is covered to restrict downward fluid flow and still allow venting of air from the shroud. This arrangement is described in detail in ANSI/HI 9.8-1998 (Reference 1). It is recommended that the inlet piping be sized to limit draw-down of the liquid below the minimum required level during the startup to a period of less than 3 seconds.



## SUCTION PIPING

**Single Pumps** Piping to the suction of a dry-pit centrifugal pump (Figure 22) must be carefully planned to provide uniform, straight-line flow to the impeller, and adequate pressure and sealing against leakage, in or out. Air pockets just prior to entrance to the pump should be avoided, as well as down flow lines subject to sudden pressure changes. Air pock-



**FIGURE 22** Suction piping faults for dry-pit centrifugal pump. (a) Air pockets should be avoided. (b) Suction elbow should not be in a plane parallel to pump shaft. (c) Valve location may be critical to pump nozzle loading. (d), (e), Suction elbow should be one size larger than pump's, long radius and three large pipe diameters distant. (d), (f) Concentric reducer should be installed distant from pump.

ets can be prevented by proper elevations (Figure 22a). Pressure surges can be controlled by surge tanks, air tubes, and so on, which may require a system pulsation study to determine possible need and solution.

To provide an optimum flow pattern to avoid impeller disturbance, it may be necessary to have a straight run of pipe of as much as eight pipe diameters immediately prior to the pump suction (for example, following a short radius elbow or tee). Following a long radius elbow or a concentric reducer, a straight run of at least three pipe diameters is recommended (Figure 22c to f). Eccentric reducers should not be used next to the pump suction nozzle. Although installing eccentric reducers with the flat side on top will eliminate a potential air pocket, large changes in diameter could result in a disturbed flow pattern to the impeller and cause vibration and rapid wear. Pipe venting, in conjunction with a concentric reducer, may be preferable to the use of an eccentric reducer.

Ideally, a suction pipe should approach a double suction pump perpendicular to the shaft centerline. If there is an elbow in the suction piping upstream of the suction flange, it should be bringing flow from either overhead or below, not from the side of the pump. If there is a short radius elbow or other flow-disturbing device in the suction piping upstream of the suction flange, there should be at least five pipe diameters between the device and the suction flange. If a short radius elbow is in the same plane as the impeller shaft, there should be at least eight pipe diameters between the elbow and the suction flange. An incorrect installation could result in an uneven flow to both sides of the double suction impeller. This could cause a reduction in capacity and efficiency, an increase in thrust on the bearing, noise, and possible cavitation damage to the impeller.

A dry-pit pump (Figure 1g) may operate with a suction lift and therefore will be located above the liquid source. All losses in piping and fittings will reduce the available suction pressure. Suction piping should be kept as simple and straightforward as possible. Any pipe flange joint or threaded connection on the suction line should be gasketed or sealed to prevent air in-leakage, which would upset the vacuum and keep the pump from operating properly.

If expansion joints are required at the suction of a pump, an anchor should be interposed between the pump nozzle and the expansion joint to prevent additional forces from being transmitted to the pump case and disturbing rotating clearances. The same requirement applies to a sleeve coupling used to facilitate installation alignment.

Reciprocating pumps must have additional consideration because of the pulsating nature of their flow. Suction piping should be as short as possible and have as few turns as possible. Elbows should be long-radius. Pipe should be large enough to keep the velocity between 1 and 2 ft/s (0.3 and 0.6 m/s). This will generally result in pipe one to two sizes larger than the pump nozzle. High points that may collect vapor are to be avoided or, if necessary, properly vented. A pulsation dampener or suction bottle should be installed next to the pump inlet. Available *NPSH* should be sufficient to cover not only reciprocating pump requirements and frictional losses but also acceleration head (see "Surge and Vibration").

**Manifold Systems** All comments relative to single pumps apply to manifold-pump systems, as well as some additional points.

In a suction manifold, the main-line flow should not be more than 3 ft/s (0.9 m/s). Branch outlets should be at 30 to 45 degrees relative to main-line flow rather than 90 degrees, and velocity can increase to 5 ft/s (1.5 m/s) through a reducer (Figure 23). With such velocities, branch outlets can be spaced to suit pump dimensions in order to avoid crowding. Also, if the angled manifold outlet is used, pumps can be set as close to the manifold as the elbow, valve, and tapered reducer will allow.

Manifold sections beyond each branch takeoff should be reduced to such a size that the velocity remains constant. One exception to this scheme is a tunnel suction (Figure 24). The flow through the tunnel may operate independent of the pumps, which are suspended in boreholes drilled into the roof of the tunnel. Boreholes at least one-third of the tunnel diameter should be horizontally spaced at least 12 borehole diameters apart. Smaller ratios can be closer to a minimum of six diameters. Pump suction bells should be at least two borehole diameters above the tunnel roof. Velocities in the tunnel should be kept below 8 ft/s (2.4 m/s) for best pump performance.

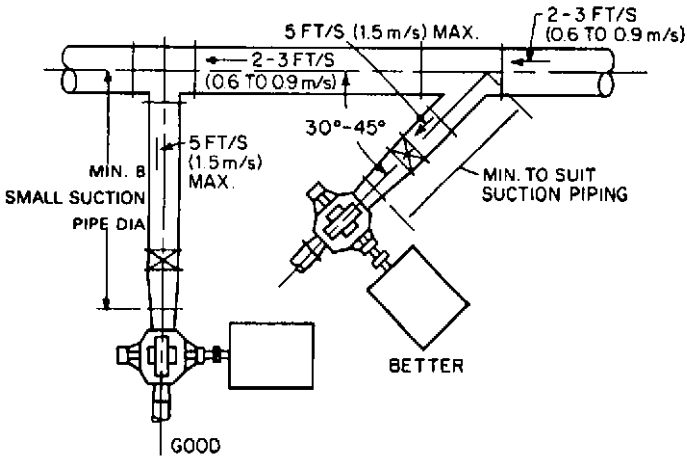


FIGURE 23 Suction pipe header recommendations for dry-pit centrifugal pump

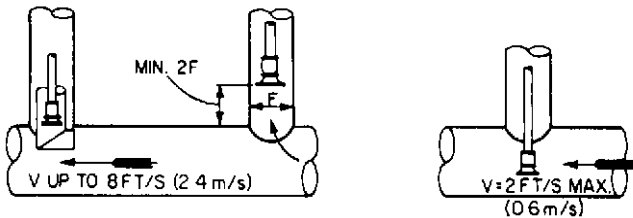


FIGURE 24 Higher tunnel velocities require isolation of pump from direct flow to prevent distortion of close-clearance parts and shaft (Hydraulic Institute Standards, 13th Edition, 1975—out of print)

**NPSH** The net positive suction head so essential to trouble-free pump operation is always reduced by losses in suction piping. An economic balance must be obtained between pump size and speed, required *NPSH*, pipe size, and suction velocity. If the suction source is a tank, such as a deaerator in a power plant, it is quite expensive to elevate the tank. Therefore, the available *NPSH* is low. The pipe size from the tank to the pump should be large for low velocity and the length should be short for minimum losses. A cooling tower on a hill supplying water to a pump station below could have a much higher pipe velocity and longer length without forcing an extremely low *NPSH* requirement on the pump.

A dry-pit pump should be as close to the suction source as possible. When the *NPSH* required indicates a suction lift is possible, the most advantageous solution is to reduce the suction losses by increasing the pipe size, flaring the inlet bell, and keeping the pump suction eye of the first-stage impeller close to the minimum water level.

**High-Pressure Inlets** Pumps in series build up pressure, so the second and following pumps will have a high-pressure suction piping connection. This emphasizes the need for tight joints and flanges and careful welding. Expansion joints should not be used because the hydraulic forces on the pump would be large, difficult to restrain, and perhaps impos-

sible for the pump to handle without distortion. As *NPSH* will not be a problem for pumps downstream of the first pump, the pipe size between pumps can be kept small to minimize design problems and valve costs.

**Effect on Pump Efficiency** Other than mechanical operation, the greatest effect of flow disturbance at the pump suction is on pump efficiency. The higher the pumping head, the lesser this effect becomes. For very high-head pumps, a high velocity may be ignored completely unless there is an extremely large power evaluation factor. Greater attention should be given to the suction pipe design for pumps producing 100 ft (30 m) of head or less than those with high head, as efficiency may be worth many dollars in power costs over the life of the plant and equipment.

Pump efficiency relates to the efficiency of the whole system, and so it may be well worthwhile to invest more money in a large suction pipe.

**Surge and Vibration** One of the possibilities arising from a power failure at a pump station is the reversal of a centrifugal pump if a valve fails to close, and its subsequent operation as a turbine. Under rated head, a pump will run from 20 to 60% above rated speed in the reverse direction. In its transition to that phase, the forward motion of the water is interrupted and gradually reversed. At the time of the power failure, the flow velocity in the suction pipe may not decelerate slowly enough to prevent a surge in the direction of the pump. The suction piping should be designed to withstand the resulting pressure rise because absolute integrity of valving and power supply will be too costly as a design parameter (see Chapter 8 for additional information on this subject).

Rotating machinery must have a design vibration frequency that is sufficiently removed from a system frequency to avoid sympathetic activity. Any combination of vibration frequencies near enough to each other to react will do so when a prime source, such as a pump, excites them. When a piping system has been designed to allow only very low stresses to be transmitted to a pump nozzle, it is quite vulnerable to vibration. It is usually good practice to analyze a suction system made up of pipe, valves, hangers, restraints, pump nozzle loads, pump speed and impeller configuration, foundation, and anchors to be sure the system is not "in tune." At the design stage, it is relatively easy to change a valve or elbow location or to add a surge suppresser. It is usually much more costly to change a pump.

Reciprocating pumps are surge producing machines. In particular, they require sufficient energy at suction to overcome pump required *NPSH* and pipe friction and a form of energy called *acceleration head*. The pump energy must overcome the acceleration-deceleration pulsation flow in the suction end, which could lead to liquid flashing with pump noise and vibration. Surges large enough to rupture the pump cylinders may also be produced.

The total *NPSH* required by a reciprocating pump must include the *NPSH* required by the pump plus frictional loss from the suction pipe plus acceleration head. Acceleration head in feet (meters) is

$$H_a = \frac{LVNC}{gK}$$

where  $L$  = actual (not equivalent) length of suction pipe, ft (m)

$V$  = velocity of flow in the suction line, ft/s (m/s)

$N$  = pump speed, rpm

$C$  = pump constant, decreasing with number of cylinders from 0.2 to 0.04

$g$  = acceleration of gravity, 32.17 ft/s<sup>2</sup> (9.807 m/s<sup>2</sup>)

$K$  = liquid constant: 2.5 for compressible fluids, 1.5 for water

The acceleration head can be reduced by installing a pulsation dampener in the suction line near the pump.

## PIPE SCREENS AND STRAINERS

---

Except for special designs for handling slurries and other solids, most pumps are limited in their ability to handle dirt, trash, and solids of any size down to microparticles. Pump passageways (volute, diffusers, impellers) handle generally spherical objects up to a “sticking size,” but a severe problem may be caused by dust-size particles that lodge in sleeve bearings, bushings, and wear rings and cause either rapid wear or rotation seizure. A wet-pit source may never be quite free from some degree of silt or sand. After it is accepted by the pump, this liquid goes into a piping system, usually one with other pumps involved. The original pit pump may also be a dry-pit type. In either case, if the pumps of a system are to operate for long periods of time with minimum maintenance, wearing parts must be protected by fine screens or strainers.

In any screening operation, it is essential to remember that if the screen is necessary and does a good job, it will plug up and thus requires cleaning. In a wet pit, therefore, neither the suction bell of a wet-pit pump nor the suction bell going to a dry-pit pump should be basket-screened. Collection of debris will soon increase inlet velocity to unmanageable proportions, and the pump operation will suffer.

It follows that if the basic screening discussed previously does not provide liquid clear enough to be pumped, additional strainers must be put into the system. The need for such strainers, and the degree of particle reduction, are usually specified by the pump manufacturer. In some instances, the system may require water as pure as it is possible to produce, as in boiler-feed service. For any situation, a variety of strainers is available.

Drum rotating strainers (Figure 12) can handle solids as small as approximately 0.01 in (250  $\mu\text{m}$ ). Backflushing is used to renew the strainer area. The addition of woven wire cloth (Table 2) to such strainers may remove materials down to 0.1 in (25  $\mu\text{m}$ ). Woven wire drum strainers used in conjunction with sand filters will reduce the amount of backflushing required for the sand filters.

Where a finer degree of filtration is required, a line filter is used. Single flow filters require system shutdown to remove and clean baskets, but either a motorized automatic type of single flow filter (Figure 25) or twin filters with alternate flow by valve arrangement (Figure 26) permit uninterrupted system operation. When a particularly difficult situation exists, a battery of filters in series may be used.

For areas where wear can be extremely critical, such as bearings and stuffing boxes (mechanical seals), additional filtering is necessary, especially if the entrained silt is abrasive. A vortex filter using centrifugal flow action will remove particles down to a few micrometers. These filters have continuous sediment removal and should not require any maintenance (Subsection 2.2.1, Figure 78).

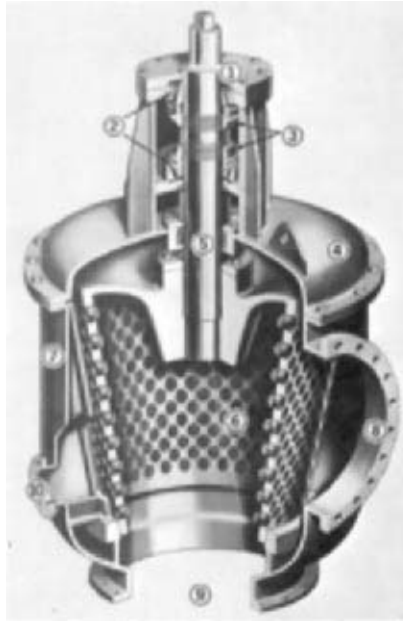
Some systems, such as boiler feedwater, are “closed” after they are in an operating cycle. Chemical and mechanical cleaning components are designed into the system to obtain a high degree of water purity. Before the system is ready to operate, however, the piping, tanks, valves, and so on, will have a residue of weld spatter, metal chips, and other debris from the fabrication process. Temporary strainers are used in the suction lines of boiler feed pumps and condensate pumps to gather up this debris. These strainers are in-line fabricated metal mesh of either a cone or box type. Feed pumps are most often equipped with cone strainers, pointing preferably upstream (Figure 27). The length and diameter are set to conform to the suction pipe size and the mesh so the velocity does not become excessive. These strainers, set between flanges in a pipe section, must be removed and cleaned whenever the differential pressure reaches 2–3  $\text{lb/in}^2$  (15 to 20 kPa). Condensate pump strainers are usually box strainers, a square section directly in front of the suction flange with a square box larger than the pipe diameter laced with egg crate metal mesh (Figure 28). This basket strainer can be lifted out of the box for cleaning as necessary. These strainers for collecting fabrication debris may be removed when the need disappears and the system will remain clean.

TABLE 2 Wire mesh data

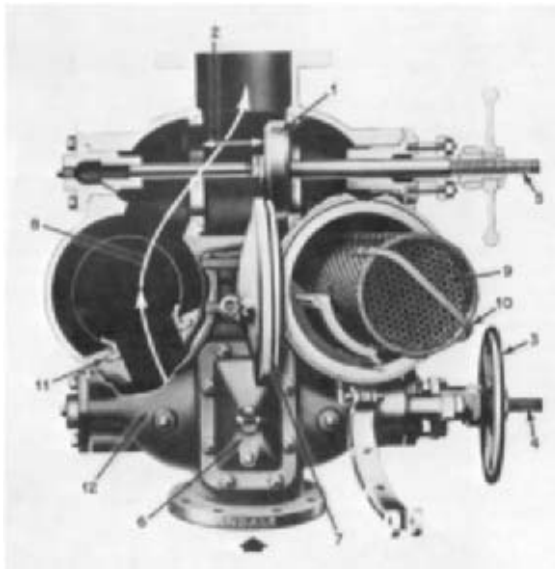
Screen mesh number, square weave	Equivalent in corduroy weave	Size		% open area	Screen mesh number, square weave	Equivalent in corduroy weave	Size		% open area
		in	$\mu\text{m}$				in	$\mu\text{m}$	
6		0.126	3327	57.2	90	20 × 120	0.0056	159	25.4
8		0.090	2362	51.8	100	20 × 150	0.0055	147	30.3
10		0.068	1651	46.2	115		0.0051	124	30.0
12		0.060	1397	51.8	120		0.0046	120	30.7
14		0.051	1168	51.0	130		0.0043	115	31.1
16		0.045	991	53.0	140		0.0042	109	34.9
20		0.033	833	43.6	150		0.0041	104	37.4
24		0.0287	701	47.4	160	20 × 200	0.0038	96	36.4
28		0.0227	589	40.4	170	20 × 250	0.0035	88	35.1
30		0.0203	495	37.1	180	20 × 300	0.0033	82	34.7
35		0.0176	417	37.9	200	20 × 350	0.0029	74	33.6
40	12 × 64	0.0150	380	36.0					
42		0.0138	351	33.6					
50		0.0105	280	27.6					
60	14 × 88	0.0077	246	21.3	120 × 330			70	
65		0.0084	208	29.8	120 × 400			40	
70		0.0068	190	22.7	120 × 600			30	
80	24 × 110	0.0070	175	31.4	200 × 600			25	

1  $\mu\text{m}$  =  $10^{-6}$  m = 1 micron = 0.00004 in; 1 in = 25.4 mm.

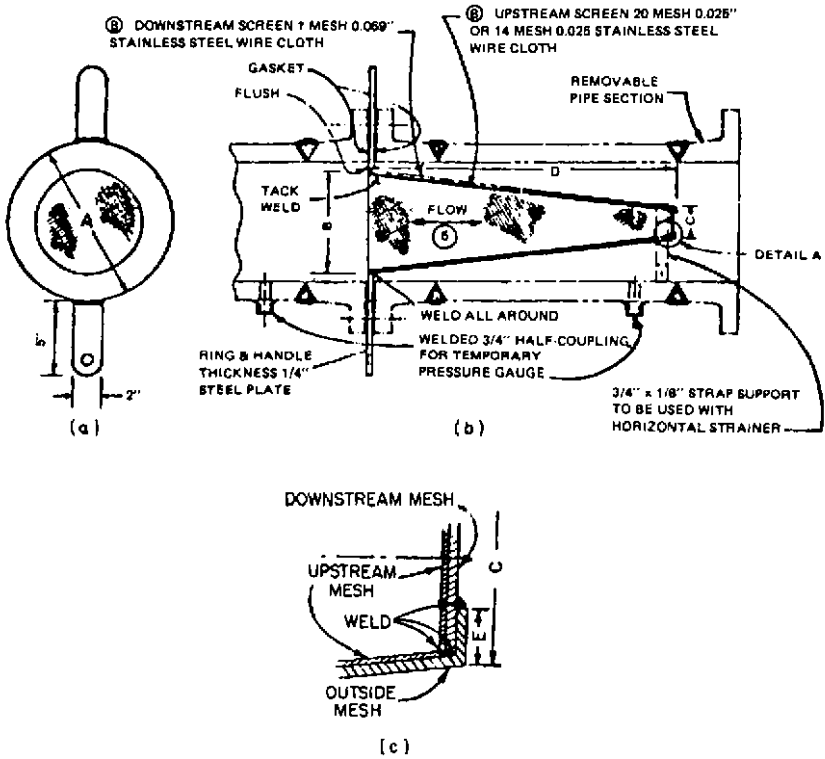
SOURCE: Green Bay Foundry & Machine Works.



**FIGURE 25** Single flow strainer with provision for backwashing without interrupting service: (1) strainer drive, (2) strainer drum support bearings, (3) lock nuts for drum adjustment, (4) cover, (5) shaft, (6) drum—tapered for adjustment, (7) body, (8) inlet, (9) outlet, (10) backwash opening (S. P. Kinney Engineers)



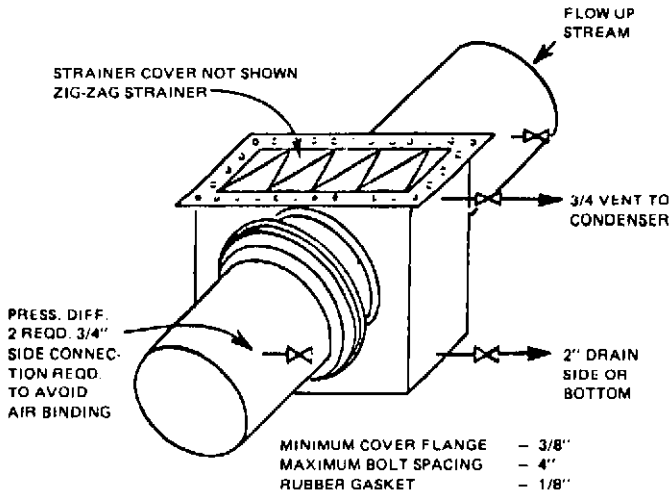
**FIGURE 26** Duplex basket strainer. Flow through one side allows cleaning of opposite basket while line is still in service. (1) positive flow diversion, (2) rapid switchover, (3) free-turning handwheels, (4) visual indication of valve position, (5) external acme threads, (6) internal access, (7) cover and clamp(s), (8) streamlined flow, (9) basket, (10) basket handle, (11) basket, (12) one-piece body construction (Andale)



Flange or pipe size	D					
	A	B	C	20 mesh 0.025-in wire, 0.025-in opening	14 mesh 0.025-in wire, 0.046-in opening	E
3	5	2- $\frac{1}{2}$	1- $\frac{1}{2}$	16	11	$\frac{1}{4}$
4	6- $\frac{3}{8}$	3- $\frac{1}{2}$	1- $\frac{1}{2}$	16	11	$\frac{1}{4}$
6	8- $\frac{1}{2}$	5	2	18	12	$\frac{1}{4}$
8	10- $\frac{1}{4}$	7- $\frac{1}{4}$	2	20	13	$\frac{1}{4}$
10	12- $\frac{1}{4}$	9- $\frac{1}{4}$	3	23	14	$\frac{1}{4}$
12	15	11	3- $\frac{1}{4}$	24	15	$\frac{1}{4}$

FIGURE 27 Cone strainer for start-up service in boiler-feed pump system. (a) cross-section, (b) lengthwise section, (c) typical detail A (nose pointing downstream). All dimensions are in inches (1 in = 0.0254 m = 2.54 cm). Strainer ring material is carbon steel. When a strainer has served its purpose, the screen portion is removed, the ID of ring is cut to suit ID of pipe, and the ring is used as a spacer. Cone strainers may be installed with nose pointing either upstream or downstream. The fine mesh screen should always be on the upstream surface of the strainer.





**FIGURE 28** Box strainer for temporary start-up service. Pressure differential connections are on top or side only. Upstream mesh is #16 stainless steel with 0.018-in (0.46-mm) wire diameter. Downstream mesh is #2 stainless steel with 0.063-in (1.6-mm) wire diameter (1 in = 25.4 mm).

## REFERENCES

1. American National Standard for Pump Intake Design, ANSI/HI 9.8-1998, Hydraulic Institute, Parsippany, NJ, [www.pumps.org](http://www.pumps.org).

## FURTHER READING

- Aten, R. E. "Alternative Cooling Water Sources for the 'Water-Short' Midwestern States." Paper presented at American Power Conference, Chicago, IL, 1979.
- Budris, A. R., and Mayleben, P. A. "Effects of Entrained Air, NPSH Margin, and Suction Piping on Cavitation in Centrifugal Pumps." 15th International Pump Users Symposium, Turbomachinery Laboratory, Texas A&M University, College Station, TX, 1998.
- Dicmas, J. L. "Development of an Optimum Sump Design for Propeller and Mixed Flow Pumps." Paper presented at ASME meeting, New York, 1967.
- Dicmas, J. L. "Effect of Intake Structure Modifications on the Hydraulic Performance of a Mixed Flow Pump." *Joint Symposium on Design and Operation of Fluid Machinery*. Vol. 1, p. 403, June, 1978.
- Dornaus, W. L. "Flow Characteristics of a Multiple-Cell Pump Basin." *Trans. ASME*, July 1958, p. 1129.
- Dornaus, W. L. "Stop Pump Problems Before They Begin with Proper Pit Design." *Power Engineering Magazine*, February 1960, p. 89.
- Fraser, W. H. "Hydraulic Problems Encountered in Intake Structures of Vertical Wet Pit Pumps and Methods Leading to Their Solution." *Trans. ASME*, May 1973, p. 3.
- Howard, J. H. G., and Hermann, P. "Flow Field Investigation for a Series of Right-Angle Minimum Axial Depth Pump Intakes." 2nd International Pump Users Symposium, Turbomachinery Laboratory, Texas A&M University, College Station, TX, 1985.

- Langewis, C., Jr., and Gleeson, C. W. "Practical Hydraulics of Positive Displacement Pumps for High-Pressure Waterflood Installations." *J. Petrol. Technol.* 23:173 (1971).
- Messina, J. P. "Periodic Noise in Circulating Water Pumps Traced to Underwater Vortices at Inlet." *Power*, September 1971, p. 70.
- Mussalli, Y. G., Hofman, P., and Taft, E. P. "Influence of Fish Protection Considerations on the Design of Cooling Water Intakes." Paper presented at Joint Symposium on Design and Operation of Fluid Machinery, Colorado State University, June, 1978.
- Prosser, M. J. "The Hydraulic Design of Pump Sumps and Intakes." BHRA, July, 1977.
- Scotton, L. N., and Anson II, D. T. "Protecting Aquatic Life at Plant Intakes." *Power*, January 1977, p. 74.
- Silvaggio, J. A., Jr. "Air Model Testing to Determine Entrance Flow Fields." 1st International Pump Users Symposium, Turbomachinery Laboratory, Texas A&M University, College Station, TX, 1984.
- Tsai, Y. J. "Sediment Control for a Power Plant Intake Screenwell." Paper presented at ASME meeting, New York, 1977.
- Wallen, P. J., and Towsley, G. S. "A Case History—Improvements to an Existing Cooling Tower Sump and Horizontal Split Case Pumps." 16th International Pump Users Symposium, Turbomachinery Laboratory, Texas A&M University, College Station, TX, 1999.

---

# SECTION 10.2

---

# INTAKE MODELING

---

MAHADEVAN PADMANABHAN  
JOHANNES LARSEN

---

## **PROBLEMS ENCOUNTERED IN PUMP INTAKES**

---

The various hydraulic problems associated with a pump pit include formation of surface and subsurface vortices, prerotation and swirl, and flow separation at or near the suction bell of either wet-pit or dry-pit centrifugal pumps (Figures 1a and 2). Any of these problems can adversely affect pump performance by causing cavitation, vibrations, or loss of efficiency.<sup>1</sup> Usually there is more than a single reason for these problems, and the extent of the combined effects is difficult to predict reliably by mathematical modeling or Computational Fluid Dynamics (CFD). Formation of vortices, for example, even though dependent on suction pipe velocity and submergence, is strongly influenced by added circulation from vorticity sources, such as a nonuniform approach flow resulting from intake and approach channel geometries; rotational wakes shed from obstructions, such as columns or piers; and the velocity gradients resulting from boundary layers at the walls and floor.<sup>2</sup> The circulation contributed by these vorticity sources is unpredictable and strongly dependent on intake design and operating conditions, especially for large pumping units with multiple bays fed by a common approach channel. In these cases, physical modeling is the best way of predicting the behavior of the prototype with a reasonable degree of reliability.

**Free Surface Vortices** This type of vortex is considered objectionable when it draws air bubbles or an air core into the pump inlet (Figure 1b). Under nominal approach flow conditions, strong air core vortices causing air ingestion with air concentration as high as 10% have been reported.<sup>29</sup> It has been established that an air concentration in the suction pipe of from 3 to 5% can lower pump efficiency.<sup>3</sup> Also, air in the form of large bubbles or slugs can cause the impeller to vibrate. Strong surface vortices that do not draw air are also objectionable if they draw debris into the suction pipes and because their high rotational velocity can reduce the local pressure sufficiently to induce cavitation.

## INTAKES AND SUCTION PIPING

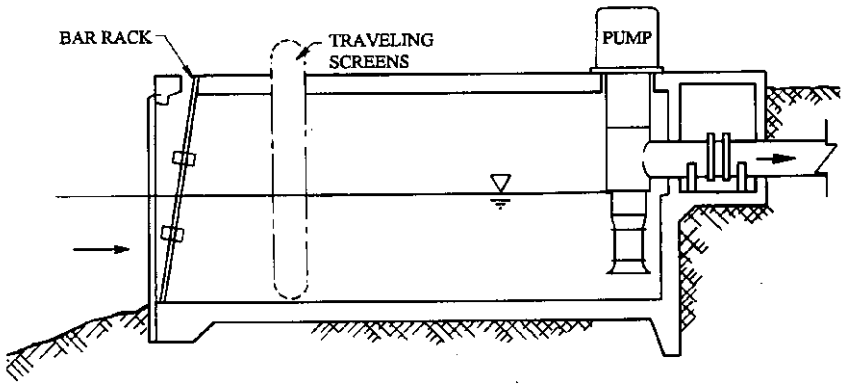


FIGURE 1A Typical vertical wet-pit pump intake.

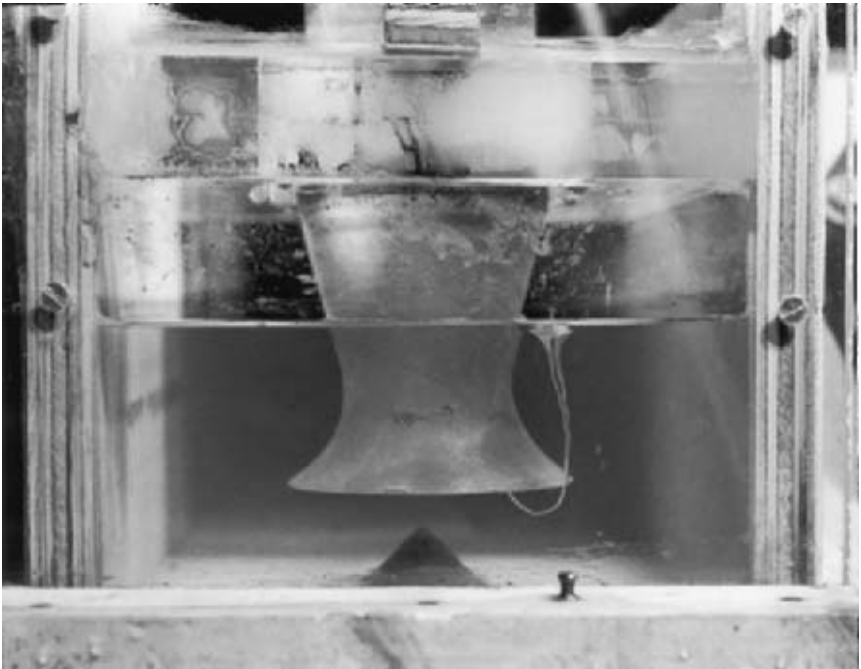
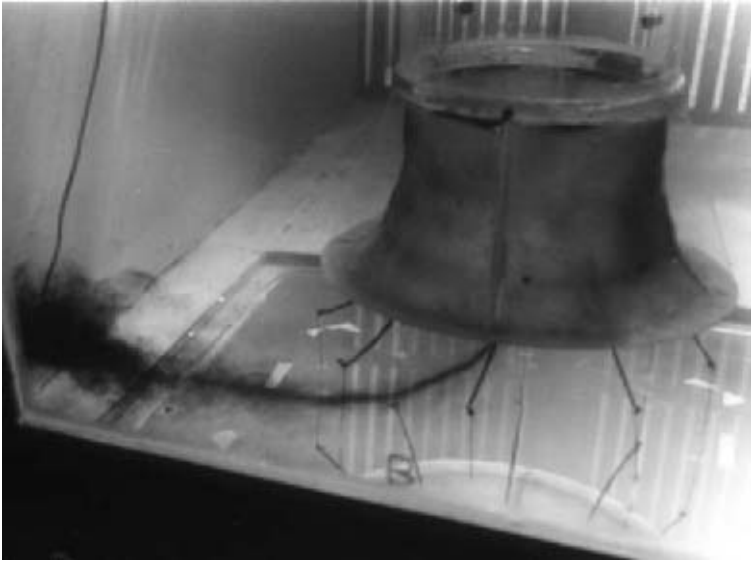
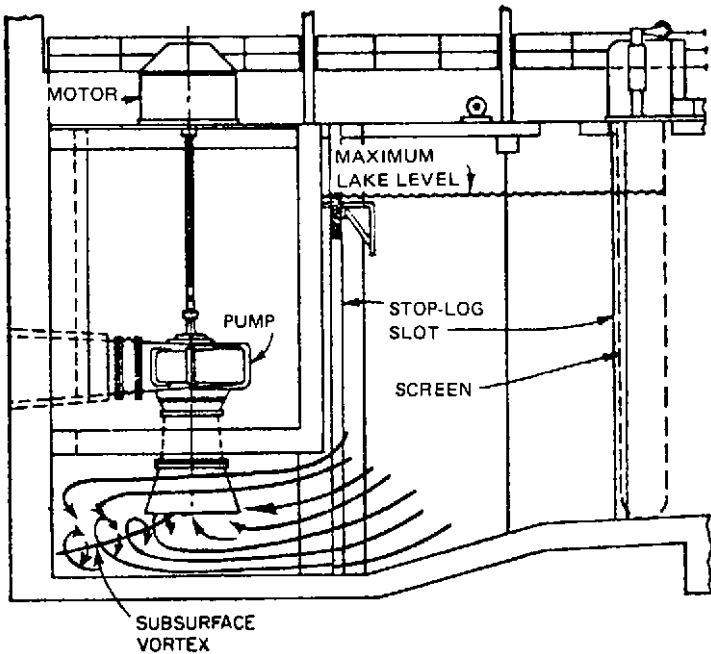


FIGURE 1B Free surface vortex can form at pump suction bell entrance due to combination of low submergence, high suction velocity, nonuniform approach flow, or other vorticity sources (Courtesy of Alden Research Laboratory, Inc.)

**Subsurface Vortices** This type of vortex, also known as a submerged vortex (Figures 1c and 2), usually originates from a floor or wall and is induced by vorticity produced in separation zones close to the pump entrance or, in wet-pit pumps, below the bell. The



**FIGURE 1C** Subsurface vortex formed at the side wall due to poor flow guidance to the bell; vortex identified in the model with dye (Courtesy of Alden Research Laboratory, Inc.)



**FIGURE 2** Typical vertical dry-pit pump intake. Improper spacing of suction bell relative to floor and back wall caused subsurface vortexing. Model test revealed problem and correction (Reference 4).

reduced pressure in the vortex core causes fluctuating load on the pump impeller along with associated vibration and noise,<sup>4,5</sup> increased possibility of cavitation, higher inlet losses, and decreased pump efficiency, especially when the core pressure is sufficiently low to release dissolved air or other gases from the fluid.

**Prerotation and Swirl** *Swirl* is a general term for any flow condition (due to vortexing or a pipe bend) where there is a tangential velocity component in addition to a usually predominating axial flow component. *Prerotation* is a specific term to denote a cross-sectional average swirl in the suction line of a pump or, in case of a vertical wet-pit pump, upstream of the impeller.

The prerotation angle  $\theta$  is a measure of the strength of the tangential velocity component  $u_t$  relative to that of the axial velocity component  $u$  in the flow approaching the pump impeller; that is,  $\theta = \tan^{-1}(u_t/u)$ . Adverse effects on the pump are decreased capacity and head when the rotation is in the direction of pump rotation and increased capacity and head when the rotation is opposite the pump rotation (antirotation). The increased capacity is associated with an increase in power requirement and may cause motor overheating.

Prerotation will influence pump performance because the flow approaching the impeller already has a rotational flow field that may oppose or add to the impeller rotation, depending on direction. The design of the pump blades (that is, shape and angle) usually assumes no prerotation, and the existence of prerotation implies flow separation along one side of the impeller blades. The degree of prerotation that should be of concern depends on the type of pump and may not always be known. Prerotation could be quantified in a model by an average cross-sectional swirl angle, determined by detailed velocity measurements, or by readings on a swirl meter. Because swirl decays along a pipe as a result of wall friction, internal fluid shear, and turbulence, the swirl meter in a model suction pipe should be located near the impeller.

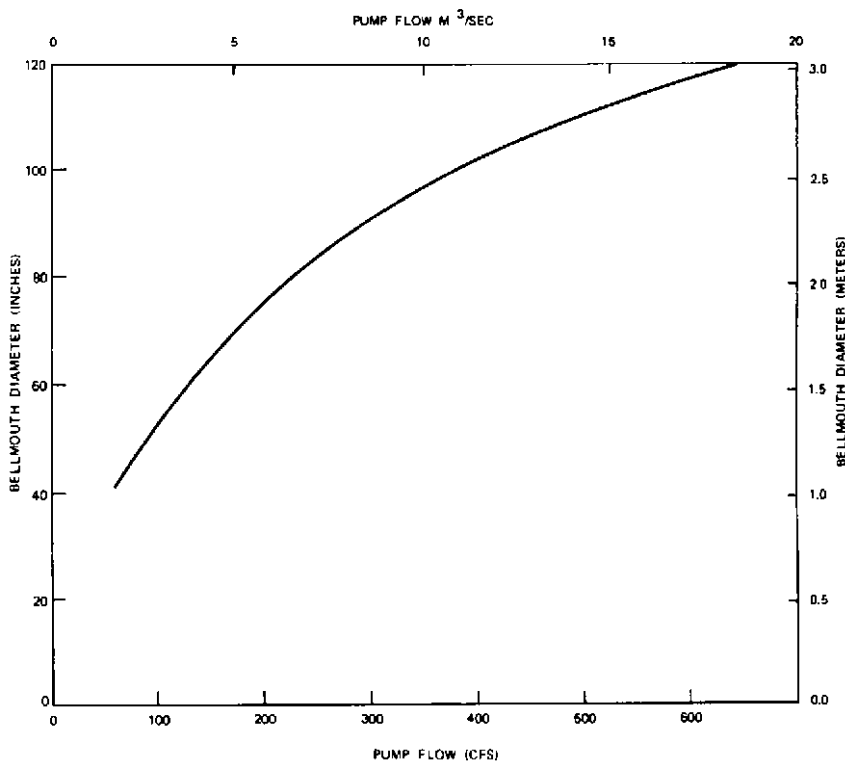
**Losses Leading to Insufficient NPSH** A poorly designed pump intake could result in large inlet losses. Losses caused by screens, poor entrance conditions, vortexing and swirl, and vortex suppression devices may add up to a value so great that the required *NPSH* of the pump is not satisfied. Increased inlet losses due to swirl have been reported in laboratory studies.<sup>6</sup> In a nuclear reactor residual-heat-removal sump model, inlet losses in a preliminary design wherein air core vortices and a high degree of swirl were present were 20% higher than in a revised design with no strong vortices and swirl, and with similar pipe entrance geometry and flows. Because the degree of vorticity and swirl cannot be predicted and it is therefore not possible to calculate inlet losses reliably; they are usually obtained from model studies. With the experimentally derived values of the inlet losses, the *NPSH* available should be checked by recalculation.

## DESIGN GUIDES

---

As a preliminary design guide (Section 10.1), published information may be used to establish pump sump dimensions and a minimum desired submergence.<sup>7-10</sup> Figures 1 and 2 of Section 10.1 show the basic layout of a pump sump and present typical dimensions in relation to the flow required per pump, as published by the Hydraulic Institute.<sup>7</sup> Some of these references may express sump dimensions in terms of bell mouth diameter, and Figure 3 shows the typical relationship between design flow for a given wet-pit pump and the bell mouth diameter required to achieve reasonable and desirable velocities approaching the impeller. One should be aware that the sump dimensions and minimum derived submergences given by design guides are considered applicable for the ideal condition of a simple, straight approach flow with a constant, low approach velocity to the pump sump.

The need for a physical model study still exists when site or operating conditions make the ideal condition impossible. For example, for a particular pump intake configuration, a hydraulic model study indicated that a strong submerged floor vortex existed with floor clearance of 0.5 times the bell diameter (a usual design value) and that a reduced floor



**FIGURE 3** An approximate relationship between design flow and required suction bell diameters for vertical propeller pumps for preliminary evaluations.

clearance of 0.3 times the bell diameter eliminated the vortex. Typically, for pump intakes of the following types, model studies should be considered essential:

1. Intakes with nonsymmetric approach flow; for example, an offset in the approach channel
2. Intakes with multiple pump bays with a common approach channel and a variety of pump operating combinations
3. Intakes with pumps of capacities greater than 40,000 gpm (2.5 m<sup>3</sup>/s) per pump
4. Intakes with expanding approach channel
5. Intakes with possibilities of screen blockages or obstructions close to suction pipe entrance; for example, reactor containment recirculation sumps, gate guides for dry-pit pumps
6. Dual flow screens intake

For items 1, 2, 4, 5, and 6, a model study is recommended because of the unknown effects a nonuniform approach flow can have on vortexing and swirl. For item 3, considering the cost of large pump installations and the cost of backfit, should problems occur, a model study is recommended to ensure proper pump operation.

**MODEL SIMILITUDE**

The principle of dynamically similar fluid motion forms the basis for the design and operation of hydraulic models and the interpretation of experimental data. The basic concept of dynamic similarity is that two systems with geometrically similar boundaries have similar flow patterns at corresponding instants of time.<sup>11,12</sup> To achieve this, all individual forces acting on corresponding fluid elements must have the same ratios in the two geometrically similar systems. The condition required for complete similitude may be developed from Newton's second law of motion:

$$F_i = F_p + F_g + F_v + F_t \quad (1)$$

where  $F_i$  = inertial force, defined as mass  $m$  times acceleration  $a$

$F_p$  = pressure force connected with or resulting from the motion

$F_g$  = gravitational force

$F_v$  = viscous force

$F_t$  = surface tension force

Additional forces, such as fluid compression, magnetic, or Coriolis forces, may be relevant under special circumstances, but generally these forces have little influence and are, therefore, not considered in the following development.

Equation 1 can be made dimensionless by dividing all the terms by  $F_i$ . Two systems of different size that are geometrically similar are dynamically similar if both satisfy the same dimensionless form of Equation 1. We may write each of the forces of Equation 1 as

$$F_p = \text{net pressure difference} \times \text{area} = \alpha_1 \Delta p L^2$$

$$F_g = \text{specific weight} \times \text{volume} = \alpha_2 \gamma L^3$$

$$F_v = \text{shear stress} \times \text{area} = (\alpha_3 \mu \Delta u / \Delta y) (\text{area}) = \alpha_3 \mu u L$$

$$F_t = \text{surface tension} \times \text{length} = \alpha_4 \sigma L$$

$$F_i = \text{density} \times \text{volume} \times \text{acceleration} = \alpha_5 \rho L^3 u^2 / L = \alpha_5 \rho u^2 L^2$$

where

$\alpha_1, \alpha_2,$  and so on = proportionality factors

$\Delta p$  = net pressure difference

$L$  = representative linear dimension

$\gamma$  = specific weight =  $\rho g$

$\mu$  = dynamic viscosity

$\Delta u / \Delta y$  = depth-wise velocity gradient

$u$  = representative velocity

$\sigma$  = surface tension

$\rho$  = density

$g$  = acceleration due to gravity

Noting that the kinematic viscosity,  $\nu$ , is given by  $\mu/\rho$ , substituting the above terms in Equation 1 and making it dimensionless by dividing by the inertial force, we obtain

$$\frac{\alpha_1}{\alpha_5} E^{-2} + \frac{\alpha_2}{\alpha_5} F^{-2} + \frac{\alpha_3}{\alpha_5} R^{-1} + \frac{\alpha_4}{\alpha_5} W^{-1} = 1 \quad (2)$$

where

$$E = \frac{u}{\sqrt{\Delta p / \rho}} = \text{Euler number} \propto \frac{\text{inertial force}}{\text{pressure force}}$$



$$F = \frac{u}{\sqrt{gL}} = \text{Froude number} \propto \frac{\text{inertial force}}{\text{gravitational force}}$$

$$R = \frac{uL}{\sqrt{\mu/\rho}} = \text{Reynolds number} \propto \frac{\text{inertial force}}{\text{viscous force}}$$

$$W = \frac{u^2L}{\sigma/\rho} = \text{Weber number} \propto \frac{\text{inertial force}}{\text{surface tension force}}$$

Because the proportionality factors  $\alpha_1$ ,  $\alpha_2$ , and so on, are the same in model and prototype, complete dynamic similarity is achieved if the values of each dimensionless group,  $F$ ,  $R$ , and  $W$  are equal in model and prototype. In practice, this is difficult to achieve. For example, to have  $F_{\text{model}} = F_{\text{prototype}}$  and  $R_{\text{model}} = R_{\text{prototype}}$  requires either a 1:1 "model" or a fluid of very low kinematic viscosity in the reduced-scale model. Hence, the accepted approach is to select the predominant force and then design the model according to the appropriate dimensionless group. The influences of the other forces become secondary and are called scale effects.<sup>11,12</sup>

**Froude Scaling** Pump intake models are generally designed and operated using Froude similarity because the flow is controlled by gravitational and inertial forces. The Froude number is, therefore, made equal in model and prototype:

$$F_r = F_m/F_p = 1 \quad (3)$$

where  $m$ ,  $p$ , and  $r$  denote model, prototype, and ratio between model and prototype.

In modeling a pump intake sump to study the formation of vortices, it is important to select a reasonably large geometric scale to achieve large Reynolds numbers. At a large Reynolds number, energy loss coefficients usually behave asymptotically with Reynolds number. Hence, with  $F_r = 1$  and a sufficiently high Reynolds number, the Euler number  $E$  will be equal in model and prototype. This implies that flow patterns and loss coefficients may be considered similar in model and prototype. From Equation 3, the velocity, flow, and time scales are

$$u_r = L_r^{0.5} \quad (4)$$

$$Q_r = L_r^2 u_r = L_r^{2.5} \quad (5)$$

$$t_r = L_r^{0.5} \quad (6)$$

For example, if a model-to-prototype scale of 1:10 is used, a prototype velocity of 1.0 ft/s (0.3 m/s) becomes a model velocity of  $(1 \div 10)^{1/2} = 0.32$  ft/s (0.09 m/s). In the model, all physical dimensions of the pump bays and approach channel are scaled to the ratio 1:10. Submergence, being a linear dimension, is also scaled to 1:10. A flow of 100 gpm (0.006 m<sup>3</sup>/s) in the model corresponds to a flow of  $100 \times 10^{2.5} = 31,623$  gpm (2 m<sup>3</sup>/s) in the prototype. Similitude parameters and laws are treated in detail in References 11 and 12.

**Similarity of Vortices** The fluid motions involving vortex formation in pump sumps have been studied by several investigators. It can be shown by principles of dimensional analysis that the dynamic similarity of fluid motion that could cause vortices at an intake is governed by the following dimensionless parameters:

$$\frac{ud}{\Gamma}, \frac{u}{\sqrt{gd}}, \frac{d}{s}, \frac{ud}{\nu}, \text{ and } \frac{u^2d}{\sigma/\rho}$$

where  $u$  = average axial velocity at the bell entrance

$\Gamma$  = circulation contributing to vortexing

$d$  = diameter of the bell entrance

$s$  = submergence at the bell entrance

- $\nu$  = kinematic viscosity of water  
 $g$  = acceleration due to gravity  
 $\sigma$  = surface tension of water air interface  
 $\rho$  = water density

The influence of viscous effects is defined by the parameter  $ud/\nu = R$ , the Reynolds number. Surface tension effects are indicated by  $u^2 d \rho / \sigma = W$ , the Weber number. As strong air-core type vortices, if present in the model, would have to be eliminated by a modified sump design, the main concern for interpretation of model performance involves the similarity of weaker vortices. If the influence of viscous forces and surface tension on vortexing is negligible, dynamic similarity is obtained by equating the parameters  $ud/\Gamma$ ,  $u/\sqrt{gd}$ , and  $d/s$  in model and prototype. A Froude model satisfies this condition, provided the approach flow pattern in the vicinity of the sump, which governs the circulation,  $\Gamma$ , is properly simulated.

Considerable research on scaling free surface and submerged vortices has been conducted in the past few years. From a study of horizontal outlets for a depressed sump, it was determined that for pipe Reynolds numbers above  $7 \times 10^4$ , no scale effect on vortex strength, frequency, or air withdrawal existed.<sup>30</sup> Another study indicated that an inlet Reynolds number of  $3 \times 10^4$  is sufficient to obtain a good model to prototype correlation of vortices.<sup>6</sup> Surface tension effects on vortexing have been shown to be negligible for Weber numbers greater than 120 based on laboratory experiments.<sup>14</sup>

A review of all available data on model versus prototype vortex intensity indicated negligible scale effects for weak vortices and small scale effects for air drawing vortices, and that this effect could be overcome by a relatively small increase in model flow rate.<sup>27</sup> The model flow rate should only be increased by an amount such that sufficient Reynolds and Weber numbers result. Excessively increasing the model flow, particularly to prototype velocity, produces highly exaggerated vortices incompatible with prototype observations.

## DESIGN AND OPERATION OF MODELS

---

**Model Scale** Scale effects are less as model size increases but construction and operation costs increase with model size, so a compromise must be made. In general, the formation of vortices, both free surface and submerged, is highly responsive to approach flow patterns, and it is important to select a geometric scale that achieves Reynolds numbers large enough to keep the flow turbulent and to meet the fluid mechanic criteria for minimizing scale effects.<sup>13</sup> Also, one should consider other factors such as access for instruments, accurate flow measurements, and ease of modification in selecting a proper scale.

Information on preferred minimum values of Reynolds number and Weber number, discussed earlier, may be used in designing a model and deciding geometric scale. However, adhering to these limits does not, in itself, guarantee negligible scale effects in a Froude model because these limits are based on tests run under ideal laboratory conditions. In real situations, there is usually more than one source of vorticity generation of unknown extent, and a generalization of scale effects for all cases would be inappropriate. To compensate for such unknown scale effects, a common practice is to test a model at higher-than-Froude scaled flows.

A special test procedure involving high temperatures may be used to determine scale effects and to project the model results to prototype ranges of Reynolds numbers.<sup>2</sup> The water temperature in the model is varied over a range, say 50 to 120°F (10 to 49°C), and flow velocities in the pipes are varied over a range of values, if possible, up to the prototype velocities. Vortexing and other flow patterns over a range of Reynolds numbers are obtained from these tests and can be used to evaluate any possible scale effects. A prediction of the prototype performance can be made based on these tests.

**Extent of Model** It is very important to include a sufficient length of approach channel in the model because approach flow nonuniformities contribute greatly to vortex formation and swirl. The decision on what approach length should be included is usually based

on the experience and engineering judgment of the model designer. The requirement is essentially the proper simulation of approach velocity profile to the intake and then on to the pump bays. In some cases, considering the cost and time involved in including a sufficient channel length in a pump intake model, a separate, smaller model can be built to determine the approach flow patterns to the intake and these flow patterns then simulated in the pump intake model.<sup>18</sup>

Figure 4a shows a 1:10 geometric scale model of a four-bay pump intake, with each pump designed to draw 140,000 gpm (312 cfs or 8.83 m<sup>3</sup>/s) flow. Figure 4b shows a 1:18 geometric scale model pump intake for a flood control project involving several low head high flow pumps—each handling 360,000 to 450,000 gpm (800 to 1,000 cfs) at 12 ft head (22.68 to 28.35 m<sup>3</sup>/s at 3.65 m head).

**Modeling of Screens and Gratings** In addition to providing protection from debris, screens suppress nonuniformities of approach flow. The aspects of flow through screens that are of concern in a model study are (1) energy loss in the fluid passing through the screen, (2) modification of the velocity profile, and (3) production of turbulence. As all these factors could affect vortex formation in a sump with approach flow directed through screens, a proper modeling of screen parameters is important.

The fluid passing through the screen loses energy at a rate proportional to the drop in pressure, and this loss dictates the effectiveness of the screen in altering velocity profiles. The pressure drop across the screen is analogous to the drag induced by a row of cylinders in a flow field and can be expressed in terms of a pressure drop coefficient  $K$  (or, alternately, a drag coefficient), defined as<sup>19</sup>

$$K = \Delta p / (0.5\rho u_a^2) = \Delta H / (u_a^2/2g) \quad (8)$$

where  $\Delta p$  = drop in pressure across screen

$u_a$  = mean velocity of approach flow to screen

$\Delta H$  = head loss across screen

The loss coefficient is a function of three variables: (1) screen pattern, (2) screen Reynolds number  $R_s = u_a d_w / \nu$ , where  $d_w$  is the wire diameter of the screen, and (3) solidity ratio  $S'$ , the ratio of closed area to total area of screen (Section 8.1).

If  $S'$  and the wire mesh pattern are the same in the model and prototype screens, the corresponding values of  $K$  are a function of  $R_s$  only. This is analogous to the drag coefficient in a circular cylinder. At values of  $R_s$  greater than about 1,000,  $K$  becomes practically independent of  $R_s$ .<sup>19</sup> However, for models with low approach flow velocity and fine wire screens, it is necessary to ascertain the influence of  $R_s$  on  $K$  for both model and prototype screens before selecting screens for the model that are to scale changes in velocity distribution.

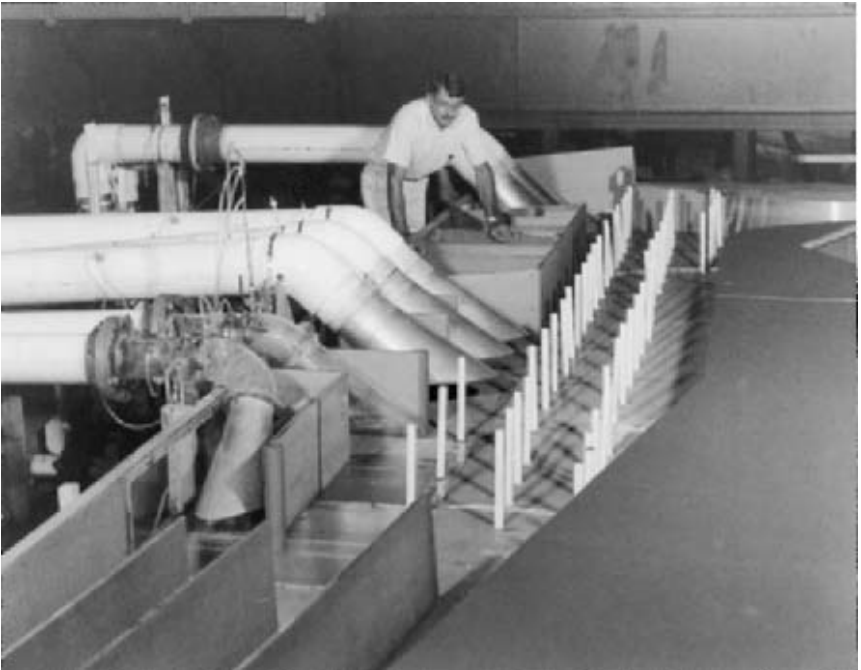
Velocity modification equations relating the upstream and downstream velocity profiles usually indicate a linear relationship between the two, the shape and solidity ratio of the screen, and the value of  $K$ .<sup>20</sup> If wire shapes and solidity ratios are the same in model and prototype, it is possible to select a suitable wire diameter to keep the values of  $K$  approximately the same for the model and prototype screens in the corresponding Reynolds number ranges. This produces a head loss across the model screen that is scaled to the geometric scale of the model and that produces identical velocity modifications in model and prototype. Some model designers consider it a conservative approach to leave out the screens in the model altogether, under the assumption that this omission will only worsen the nonuniformity of the approach flow. This approach is not recommended unless it is not practically possible to select an appropriate model screen.

**Modeling of Pumps** The exterior submerged surfaces of the pump bowl assembly and, for wet-pit pumps, the column including the bell mouth must be modeled to scale as well as the interior geometry from the bell mouth perimeter to the impeller eye. This is to ensure that flow patterns approaching the impeller are properly simulated.

Prerotation induced by the pump's rotating element is discussed in Sections 2.3 and 10.1 and in References 21 to 24. It has been shown that the rotating element does not affect upstream flow patterns when the pump is operated at design flow, and hence,



**FIGURE 4A** A 1:10 geometric scale model of a four pump-bay pump intake (Courtesy of Alden Research Laboratory, Inc.)



**FIGURE 4B** A 1:18 geometric scale model of a flood control pumping station with high capacity (800 to 1000 cfs/22.7 to 28.3 m<sup>3</sup>/s), low head (about 12ft/3.65 m) pumps (Courtesy of Alden Research Laboratory, Inc.)

including the rotating element in a pump intake study is not necessary. When the pump is operated at less than rated flow, a degree of swirl is induced upstream of the rotating element. This swirl increases rapidly at flow rates less than 45% of rated flow as reversed flow out of the impeller intensifies, and this may affect vortex activity in the pump well and flow distribution to the pump.

**Model Operation** Operating a model at the prototype suction pipe velocity is thought to be a conservative method to compensate for excessive viscous energy dissipation and the consequent less intense model vortices in a Froude model.<sup>17</sup> This method is often referred to as the Equal Velocity Rule. Operating a model at a higher than Froude scaled velocity should be considered a reasonable procedure for evaluating scale effects. However, operating a model based on the equal velocity rule may not be advisable unless the model is large enough, say at least a 1:4 scale model, because increasing the flow to many times the Froude scaled flow while keeping a scaled submergence could distort the approach flow patterns and turbulent intensities and, thus, cause unrealistic results. In general, a velocity increase to about 1.5 times the Froude scaled velocity can be considered reasonable. More appropriately, the information contained in References 25 and 26 may be used to decide the velocity ratio for exaggeration, which often is considered a function of model scale. If the final recommended design does not show any coherent core vortices in a model, no large scale effects should be expected, and operating the model at higher than Froude scaled flows may be unnecessary in such cases.<sup>27</sup>

**Model Cost** The cost of model studies varies considerably and is dependent on such factors as number of pump bays, number of operating conditions, and complexity of approach flow. Typically, \$40,000 to \$90,000 (in 1999 U.S. dollars) can be expected to cover the range from simple one- or two-bay sumps to multibay installations with complex approach flow and several operating modes.

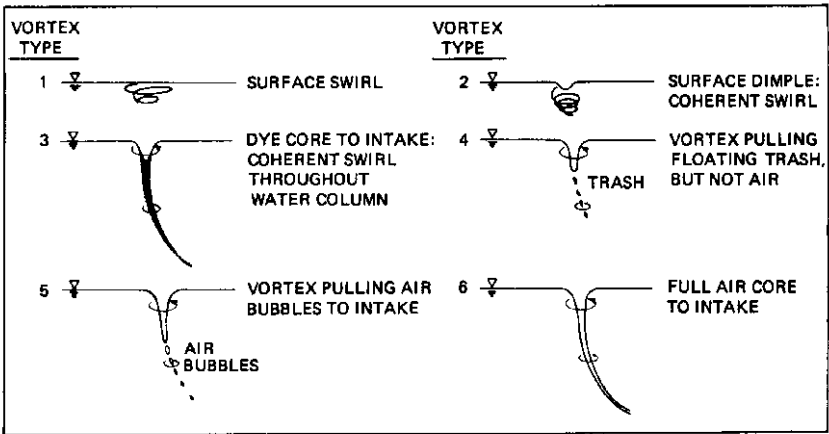
## MODEL OBSERVATION TECHNIQUES

---

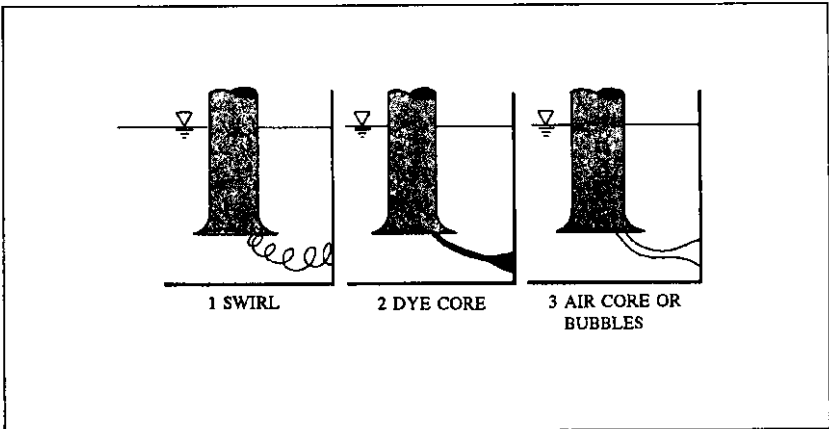
**Free Surface Vortices** Vortices in a model usually contain little energy, and therefore, vortex circulation cannot readily be measured because any measuring device will affect the strength of the vortex. Therefore, vortex strength is best characterized by visual observation and classified by comparison with a vortex strength scale, such as the one shown in Figure 5a. Observations are carried out continuously for a representative period of time, usually one hour prototype, and the resulting data are analyzed in terms of the maximum observed vortex strength and in terms of persistence; that is, the percentage of time a given vortex strength occurred.<sup>28</sup> Vortices of Type 5 and 6 are clearly objectionable in an intake design because of the effect air entrainment and localized pressure reductions have on pump performance. Usually in model studies, a vortex type of 3 is considered the maximum allowable, as prototype strength may be slightly underestimated as a result of possible scale effects.

**Sub-Surface Vortices** Vortices attached to fixed boundaries below the surface can be difficult to detect and may require a careful search with a dye tracer or an air-injection technique. The vortex strength is best characterized by visual observations and classified by comparison to a vortex strength scale such as one shown in Figure 5b. A strong sub-surface vortex may reduce the pressure locally within its core sufficiently low to allow dissolved air to come out of solution resulting in an air core (Type 3 in Figure 5b).

Submerged vortices are most commonly found below the center of wet-pit pumps and around splitter plates introduced to even out flow into the bell mouth. Pressure measurements made with electronic pressure transducers located in the floor under the pump may provide information on rapidly forming and disappearing vortices that cannot be detected with flow visualization. Sub-surface vortices should, as far as practical, be eliminated from any design because their presence imposes fluctuating loads on the impeller and the resulting low-pressure areas may cause local cavitation damage to the pump.



a. FREE-SURFACE VORTICES



b. SUBSURFACE VORTICES

FIGURE 5A and B Vortex strength scale (Courtesy of Alden Research Laboratory, Inc.)

**Prerotation** The tangential velocity component may be measured by a swirl meter, or vortimeter, which is an impeller with zero pitch in the axial direction mounted axially in the pump column two to four column diameters downstream from the suction bell. A typical vortimeter is shown in Figure 6. Vortimeter rotation is measured by either electronic or manual counting of rotation over a given time. Prerotation can also be determined from velocity traverses obtained with a two-dimensional pitot tube.

**Intake Loss Coefficient** Water manometers connected to piezometric taps along the pipe are used to measure the hydraulic gradient along the suction pipe. An intake loss coefficient is then determined by extrapolating the measured hydraulic gradient to the suction pipe inlet and computing the head loss  $h_L = \Delta h - u^2/2g$ , where  $\Delta h$  is the differ-



FIGURE 6 Swirl meter in a model pump column (Courtesy of Alden Research Laboratory, Inc.)

ence between the pump pit water surface and the extrapolated pressure gradeline at the pipe inlet. With this procedure, the computed head losses will not include any pipe frictional losses and consequently any model pipe Reynolds number influence is avoided. At the same time, pressure measurements are done far downstream from the region of flow separation near the entrance, and hence, more accurate measurements of total pressure loss, including entrance losses, are obtained. The loss coefficient  $C_L$  is usually defined as  $C_L = h_L/(u^2/2g)$ , where  $(u^2/2g)$  represents the velocity head in the pipe. The computed model loss coefficient is valid for the prototype, and hence, the prototype inlet losses are  $C_L$  times the prototype pipe velocity.

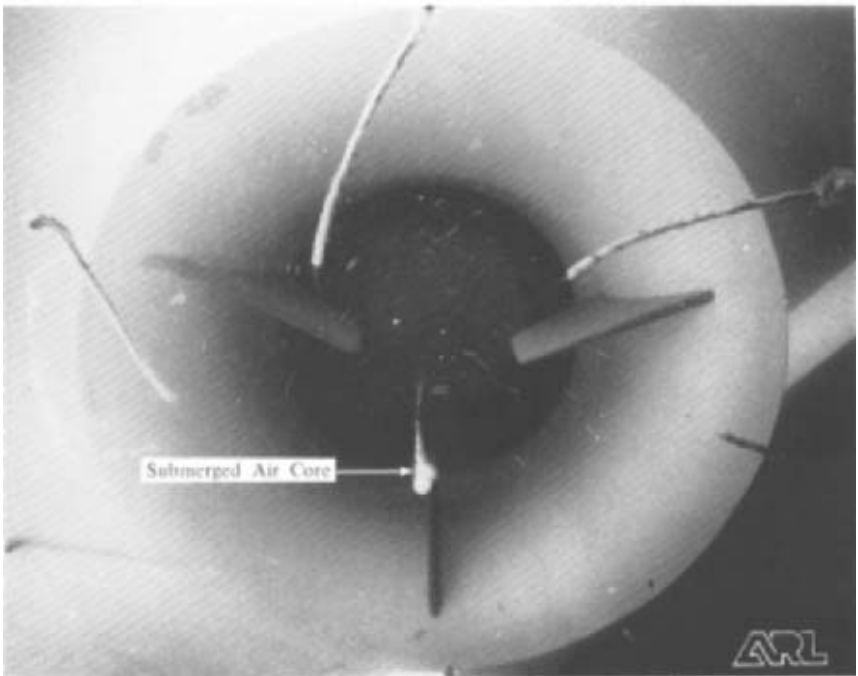
**Flow Distribution** Radial flow under the perimeter of the pump bell is required to avoid vibrations and loss in efficiency caused by uneven impeller loading. Flow direction is usually indicated by six to eight yarn streamers equally spaced and mounted on wire supports 0.2 bell mouth diameter below the bell mouth perimeter. Figure 7 shows a typical installation. For an acceptable design, these streamers should not deviate more than 10 to 15° from radial. Velocity distribution approaching the pump is usually measured with miniature propeller meters.

### CORRECTIVE MEASURES

---

Problems in pump sumps such as severe vortexing, intense swirl, or uneven flow distribution at the bell can be reduced or eliminated by deriving proper corrective methods using models. Because no single remedial method to correct these problems exists, it is important to try several suitable methods in the model to derive an effective and practical one.





**FIGURE 7** Yarn streamers around the suction bell of a model intake to observe flow direction into the bell (Courtesy of Alden Research Laboratory, Inc.)

Even though the pump bell velocity and submergence are very important parameters contributing to problems, it is seldom possible to change these values. Hence, the corrective measures are usually incorporated in the geometry of the pump pit and include the introduction of suitable appurtenant devices.

Severe free surface vortices may be prevented by providing a uniform approach flow to the pumps while maintaining a sufficient submergence. Required submergences can be predicted by empirical equations available in the literature.<sup>31</sup> Relocation of pumps, introduction of horizontal grids below the water surface, changing of wall and floor clearances, improvements in approach channel configurations, and changes in lengths and spacing of piers are some of the common techniques for reducing vortex activity. Surface vortices can also be controlled by installing a curtain wall immediately upstream of the pump. Figure 8 indicates various methods of eliminating poor flow conditions as given in Reference 7.

Submerged vortices are usually eliminated by installing splitter vanes or floor cones under the bell. Variations in floor and wall clearances can also be effective and should be tried in the model. Figure 9 shows a 1:4 scale model of a two-bay pump intake—each pump designed to draw 25,000 gpm (1.575 m<sup>3</sup>/s). Flow distributor walls are installed to assure a nearly uniform flow to the pumps, and splitters and fillets are provided to guide the flow into the pump bells without any sub-surface vortices.

The choice of corrective measures should always be made with the pump use in mind. For example, in testing pump intakes that will be used for sewerage, corrections that will allow trash build up, such as vanes or grids, should be avoided. It is also important that a continuous dialogue exist between the intake designer and the test laboratory so the most practical and inexpensive solution for a specific installation can be obtained with a minimum of effort.



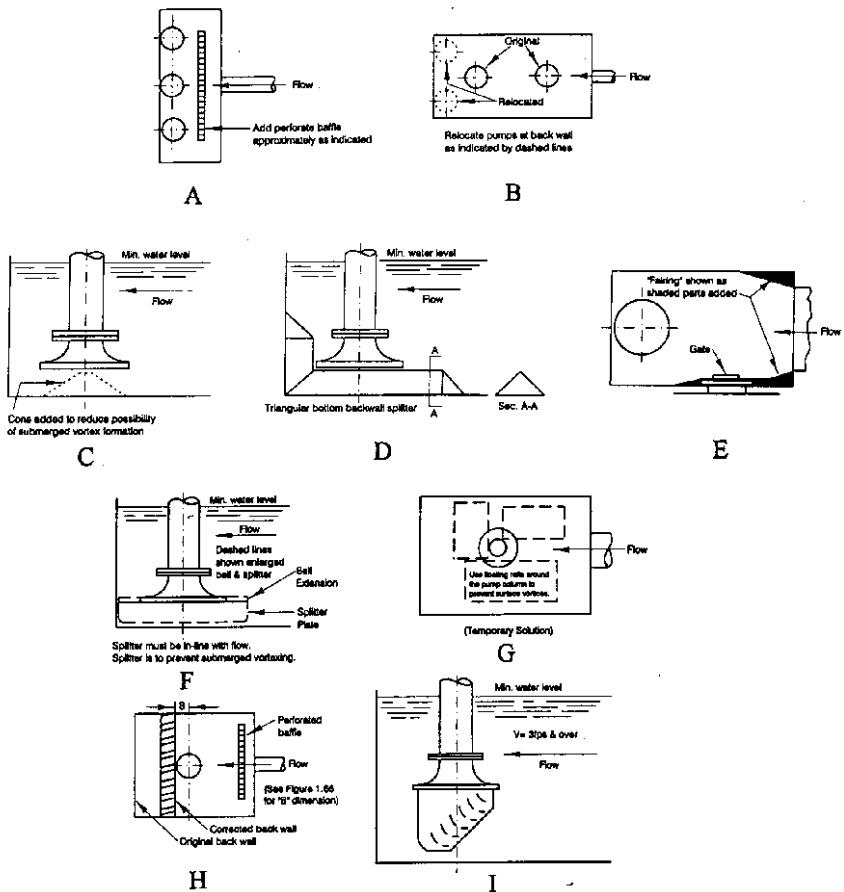
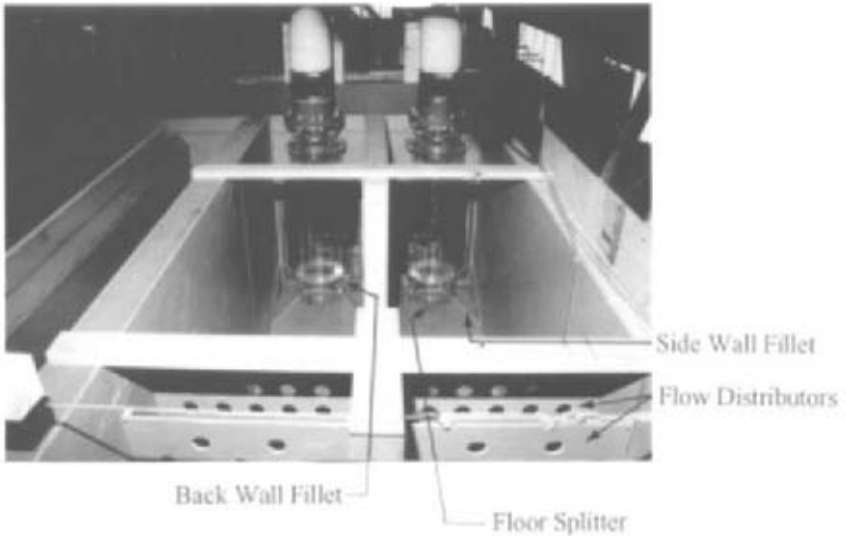


FIGURE 8A through I Common method of eliminating vortexing problems in pump pits (Hydraulic Institute ANSI/HI 2000 Edition Pump Standards, Reference 7)



**FIGURE 9** A 1:4 geometric model of a two-bay intake showing flow distributors, splitters, and fillets to eliminate objectionable vortices (Courtesy of Alden Research Laboratory, Inc)

## REFERENCES

1. Tullis, J. P. "Modeling in Design of Pumping Pits." *Journal Hydraulic Division, ASCE*, September 1979, p. 1053.
2. Durgin, W. W., and Hecker, G. E. "The Modeling of Vortices at Intake Structures." In *Proceedings of the ASCE, IAHR, and ASME Joint Symposium on Design and Operation of Fluid Machinery*, Colorado State University, Fort Collins, CO, June 1978, Vol. 1, p. 381.
3. Murakami, M., and others. "Flow of Entrained Air in Centrifugal Pumps." In *Proceedings of the 13th Congress IAHR*, Kyoto, Japan, 1969, Vol. 2, p. 71.
4. Messina, J. P. "Periodic Noise in Circulating Water Pumps Traced to Underwater Vortices at Inlet." *Power*, September 1971, p. 70.
5. Denny, D. F. "Experimental Study of Air-Entraining Vortices in Pump Sumps." In *Proceedings of the Institution of Mechanical Engineers*, London, 1956, p. 1.
6. Daggett, L. L., and Keulegan, G. H. "Similitude Conditions in Free Surface Vortex Formations." *Journal Hydraulic Division, ASCE*, November 1974, p. 1565.
7. American National Standard for Pump Intake Design, ANSI/HI 9.8-1998, Hydraulic Institute, Parsippany, NJ [www.pumps.org](http://www.pumps.org).
8. Chang, E., and Prosser, M. J. "Intake Design to Prevent Vortex Formation." In *Proceedings of the ASCE, IAHR, and ASME Joint Symposium on Design and Operation of Fluid Machinery*, Colorado State University, Fort Collins, CO, June 1978, Vol. 1, p. 393.
9. Sweeny, C. E., Elder, R. A., and Hay, D. "Pump Sump Design Experience Summary." *Journal Hydraulic Division, ASCE*. March 1982, p. 361.
10. Reddy, Y. R., and Pickford, J. A. "Vortices at Intakes in Conventional Sumps." *Water Power* **24**(3): 108, 1972.
11. Rouse, H. *Handbook of Hydraulics*. Wiley, New York, 1950.
12. Daily, J. W. and Harleman, D. R. F. *Fluid Dynamics*. Addison-Wesley, Reading, MA, 1966.

13. Anwar, H. O. "Prevention of Vortices at Intakes." *Water Power*. October 1968, p. 393.
14. Jain, A. K., and others. "Vortex Formation at Vertical Pipe Intakes." *Journal Hydraulic Division, ASCE*. October 1978, p. 1429.
15. Hattersley, R. T. "Hydraulic Design of Pump Intakes." *Journal Hydraulic Division, ASCE*, March 1965, p. 223.
16. Anwar, H. O., and others. "Similarity of Free Vortex at Horizontal Intake." *Journal Hydraulics Res*, 2: 95, 1978.
17. Denny, D. F. and Young, G. A. J. "The Prevention of Vortices and Swirl at Intakes." Paper No. C1 in *Proceedings of IAHR 7th Congress*, Lisbon, 1957.
18. Larsen, J., and Bozoian, P. M. "Model Studies of Intake Pumphouse for the Perry Nuclear Power Plant Cooling Towers." Report 153-77/M294EF, Alden Research Laboratory, Inc., Holden, MA, 1977.
19. Padmanabhan, M., and Vigander, S. "Pressure Drop Due to Flow Through Fine Mesh Screens." *Journal Hydraulic Division, ASCE*, August 1978, p. 1191.
20. Baines, W. D., and Peterson, E. G. "An Investigation of Flow Through Screens." *Trans. ASME* 73: 467, 1951.
21. Toyokura, T. "Studies on the Characteristics of Axial Flow Pumps, Part 1." *Bull. Japanese Society Mechanical Engineering* 4(14):287, 1961.
22. Minami, S., and others. "Experimental Study on Cavitation in Centrifugal Pump Impellers." *Bull. Japanese Society Mechanical Engineering* 3(9): 19, 1960.
23. Kurian, T., and Radhakrishna, H. C. "A Study of the Phenomena of Pre-Rotation at the Suction Side of Centrifugal Pumps." *Irrigation and Power*, July 1974, p. 381.
24. "Prerotation in Pumps Induced by the Impeller." Internal Technical Memo, Alden Research Laboratory, Inc., Holden, MA, July 1980.
25. Zajdlik, M. "New Checking Mode of Model Parameters for Vortex Formation in Pump Tanks." In *Proceedings of the IAHR 17th Congress*, Baden-Baden, Germany, 1977, p. 379.
26. Chang, E. "Scaling Laws for Air-Entraining Vortices." Report No. RR1519, British Hydromechanics Research Association, Cranford, Bedford, England, 1979.
27. Hecker, G. E. "Model-Prototype Comparison of Free-Surface Vortices." *Journal Hydraulic Division, ASCE*, October 1981, p. 1243.
28. Larsen, J., and Pennino, B. J. "Hydraulic Model Study of Jefferson Parish Drainage Pump Station No. 3." Report 68-81/M429F, Alden Research Laboratory, Inc., Holden, MA, 1981.
29. Padmanabhan, M. "Air Ingestion Due to Free-Surface Vortices." *Journal Hydraulic Engineering, ASCE*, December 1984, p. 1855.
30. Padmanabhan, M., and Hecker, G. E. "Scale Effects in Pump Sump Models." *Journal Hydraulic Engineering, ASCE*, November 1984, p. 1540.
31. "Swirling Flow Problems at Intakes." Edited by J. Knauss, IAHR Hydraulic Structures Design Manual, A. A. Balkema, Rotterdam, 1987.

**SELECTING  
AND  
PURCHASING  
PUMPS**

**Vinod Patel**

**Trygve Dahl**

## STEPS IN THE PROCESS

---

After the initial decision that pumping equipment is required, purchasing of the equipment can be divided into the following general steps.

- Engineering of the pumping system
- Selection of the pump and driver type
- Pump specification and data sheet preparation
- Inquiry and quotation
- Evaluation of bids and negotiation
- Purchase of the selected pump and driver

In the process of specifying pumping equipment, the engineer must determine system requirements and system head curves, select pump type, write the pump specification, complete the pump data sheet, determine testing, inspection and vendor drawing and data submittal requirements and develop all the data necessary to define the required equipment from the supplier.

Having completed this phase of work, the engineer is then ready to take the steps necessary to purchase the equipment. These steps include issuing the pump inquiry to the bidders, technical and commercial evaluation of pump bids, selection of the supplier, and release of data necessary to issue the purchase order. The ultimate result of this process is the selection of a pump/driver combination that satisfies both the process and mechanical requirements.

## ENGINEERING OF PUMPING SYSTEM REQUIREMENTS

---

The first step is to define the requirements and conditions under which the equipment will operate.

**Fluid Type** A thorough description of the fluid to be handled must be developed. This includes properties such as viscosity, density, vapor pressure, corrosiveness, erosiveness, volatility, flammability, and toxicity. Depending on the process and the system, some or all of these properties may have an important effect on the pump and system design. For example

- The corrosiveness of the fluid will influence the materials of construction.
- If the fluid contains solids in suspension, suitable types of pump seal designs and abrasion-resistant pump construction must be considered.
- Erosion due to high particle content may cause premature performance decline. Large particles may favor open impeller design.
- Fluid toxicity may necessitate the use of dual (tandem or double) mechanical seals due to government regulations or safety considerations.
- Entrained gases may affect the pump's ability to produce the required differential pressure.

The specified fluid physical and chemical properties must cover the entire expected operating range of the pumping system. Influences such as varying temperatures and pressures must also be defined.

**System Head Curves** The engineer must have a clear understanding of the process and system in which the pumping equipment will operate. A preliminary design of the system should be made and should include an equipment layout and a P&ID (piping and instrument diagram). These preliminary drawings will show the various fluid flow paths

for system operation, preliminary pipe diameters and lengths, relative elevations of system components and all valves and other piping components that will be used to establish the system head losses. These drawings will be used by the engineer to calculate the final piping sizes and pumping system head requirements.

With this information, the engineer can develop system head curves that show the relationship between flow rate and hydraulic losses in the piping system. In determining the hydraulic losses, the engineer must include adequate allowances for future corrosion and scale deposits in the piping system over the plant life.

Because hydraulic losses are a function of flow rate, pipe size, and layout, each individual flow path alignment in a given system will have its own characteristic operating curve. Care must be taken when specifying the required pump characteristics to take into account all possible system operating flow paths. It is convenient to add the effects of static pressure and elevation differences in the system to form a combined system head curve. This combined curve shows the total head required of the pumping equipment to overcome system resistance as well as differential static pressure and elevation. The pump head must be at or above the combined system curve at all required operating points and fluid conditions for the various system flow paths. Refer to Sections 8.1, 8.2, 9.1, and 9.2 for guidance in constructing system head curves.

**Modes of System Operation** System operating modes are important considerations when specifying pumping equipment. Will the pump be used in continuous or intermittent operation? Will the pump operate in parallel or series with other pumps? Will there be significant differences in head or flow rate requirements in different system alignments? Will a single pump be used as a common spare for two different pumping applications? These and other questions arising from analyzing the different modes of operation will help influence decisions as to the number of pumps needed, heads and capacities and whether booster pumps are desirable in some system alignments. It should be noted that unnecessarily conservative hydraulic requirements may increase pump complexity (such as the selection of a more elaborate multistage or double suction pump in place of simpler single stage, overhung pump) and cost.

The engineer should also consider the length of time between plant maintenance expected of the pumping system. This factor will influence the decision of quantity, pump type, requirement for installed spare(s), and the manufacturing quality required of the specified pumps. Frequently, due to the critical nature of a pumping service where high reliability is necessary, installed spares are provided. In some cases, 2–100% pumps are provided. When system flowrate requirements fluctuate, 3–50% pumps may be called for. When reduced flowrates will not adversely affect operations, 2–50% pumps can be specified. Plant operating philosophies will dictate if automatic start of a spare pump is required.

**Pump Flow/Head Margins** Pumps are normally specified with a capacity margin above what has been determined necessary for the process. In addition, the calculated system head losses are also determined conservatively. The reasons for this include the following:

- During system design, many assumptions are made while determining pump requirements, some of which might eventually be determined to be incorrect.
- During the plant life cycle, process conditions are likely to change due to aging catalyst, changes in feed stock, seasonal feed temperature variations, and so on.
- Final piping design may be significantly different from preliminary design.
- System hydraulic losses may change due to corrosion, and so on.

During preliminary system design, these potential future changes in head/capacity must be studied to determine the required design margin. Because a pump should be selected to operate close to its best efficiency point, it is important to minimize the selected margin. Margins of 5 to 10% on flow are typical but even 20% is common, for example, in reflux tower service. In cases where the process is well proven and understood, and system operating requirements are well defined, a zero margin is sometimes appropriate.

Plans for future capacity increase may be foiled if the piping system does not provide for adequate net positive suction head at the future flow conditions.

Care must be taken when applying margins to ensure that the purchased pump is not oversized. If the total head produced is too large, impellers may be trimmed within the allowable range of the pump model provided. If the flow is significantly oversized, a costly energy penalty can result over the life of the plant. This is caused by lower pump operating efficiency at off-design flow rates and discharge throttling losses that may be necessary to control the flow rate to the desired value.

**Type of Pump Control** The type of control for the required pump is also an important consideration for pump specification and selection. Since the actual piping system usually incorporates a design margin, a control valve is normally employed in centrifugal pump applications. This control valve (not supplied by the pump manufacturer) is used to adjust the system curve over the life of the unit. Flow sensing control provides the most stable operation for most systems. Pressure control can have very large swings in flow when operating in a flat or drooping area of a centrifugal pump curve. For this reason, most centrifugal pump specifications incorporate the requirement for the centrifugal pump operating curve to rise continually to pump discharge valve shut in (also known as the pump shut off).

Both temperature and level sensing control can lead to a pump running at shut off or at the end-of-curve condition during upset or failure modes. Centrifugal pumps with a 10% to 20% head rise between the specified operating point and the shut off point may be preferred for some services such as for parallel pump operation.

Pumps that may operate in the shut off condition may need a continuously open bypass to prevent pump damage. Pump manufacturers will advise of the minimum required flow for an offered pump, but many end users require an additional margin above the manufacturers recommended minimum flow. If a continuous flow bypass is incorporated in the system design, this additional flow must be added to the specified pump requirement. Refer to Section 2.3.4 for bypass designs.

**Future System Changes** A final factor to be considered is the possibility of providing for future system changes. When future system changes can be predicted with a degree of certainty, the system can be designed with this in mind. Rather than selecting a pump that is operating at the high end of its preferred operating region, a larger impeller diameter or the next larger size pump operating at the beginning of its preferred operating range might be considered. In addition, the capability for installing a larger diameter impeller to handle future higher head requirements must be considered. Because minimizing capital costs for a project is usually the prime consideration, oversizing a pump for future operations is not normal practice. Pumps are expected to operate efficiently and reliably in the present system, and this fact should be noted during the selection progress.

## **SELECTION OF PUMP, DRIVER, AND AUXILIARIES**

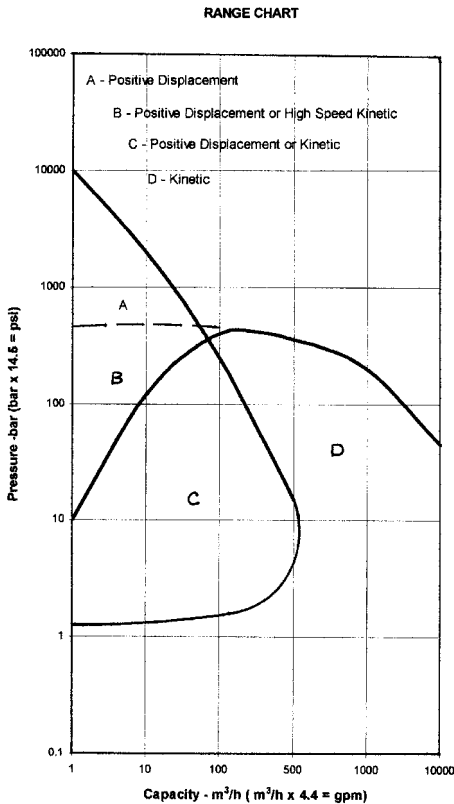
---

As stated previously, the selection of pump type for a particular application is influenced by such factors as the fluid characteristics, required materials of construction, system flow/head requirements, intended equipment life, energy cost, and availability of certain utilities, such as cooling water. Accuracy in these areas is critical for proper selection of pumps.

**Pump Types** There are several different types of basic pump designs. Each design can be used for a range of flow and head combinations. Figure 1 gives a general overview of the type of pump that can be used for various heads and flow rates.

In addition to capacity and head considerations, other operating characteristics of a pump will help the engineer to select a pump type for a given application. Some of the considerations are detailed in the following sections.

**Self Priming Requirement** If a pump is taking suction from a source below the pump suction nozzle, a self-priming capability may be necessary. Positive displacement pumps



such as a piston pump or a rotary screw or gear pump are able to self-prime within limits in the smaller capacity range. There are also special centrifugal pump designs that will self-prime in this situation.

**Variable Head/Flow Requirement** Centrifugal and axial flow pumps are able to operate in variable head/flow conditions. By reviewing the pump curve for a given pump, the head/flow range capability for these types of pumps can easily be determined. Refer to centrifugal pump operating curve, Figure 2. For a specific impeller size, a centrifugal pump will produce any flow rate within its head-flow rate characteristic curve which corresponds to the system head curve (see Figure 2), if sufficient *NPSH* is available. The system head characteristics can be changed to vary the flow by discharge throttling or by varying pump speed.

**High Head Required (Above Single Stage Centrifugal Pump Ability)** Depending on the required flow rate, either a centrifugal or a piston pump may fulfill the need for high differential head. If a relatively small flow is required, either an integrally geared high-speed centrifugal pump or a piston pump may be applied. When selecting between these two choices, other questions to ask might be



Customer : Y  
 Item No :  
 Service :  
 IDP Ref : 0150-W0000  
 Date : Jan 31, 1997



# Ingersoll-Dresser Pumps

Pump : 2HPX13A  
 Stages : 1  
 Curve : 2HPX13A-1-1

Flow (US gpm) : 293. SG : 1.00  
 Head (ft) : 634. RPM : 3540

CURVES ARE APPROXIMATE. PUMP IS GUARANTEED FOR THE SET OF CONDITIONS. CAPACITY, HEAD AND EFFICIENCY GUARANTEES ARE BASED ON SHOP TEST WHEN HANDLING CLEAR FRESH WATER AT A TEMPERATURE OF NOT OVER 65 F.

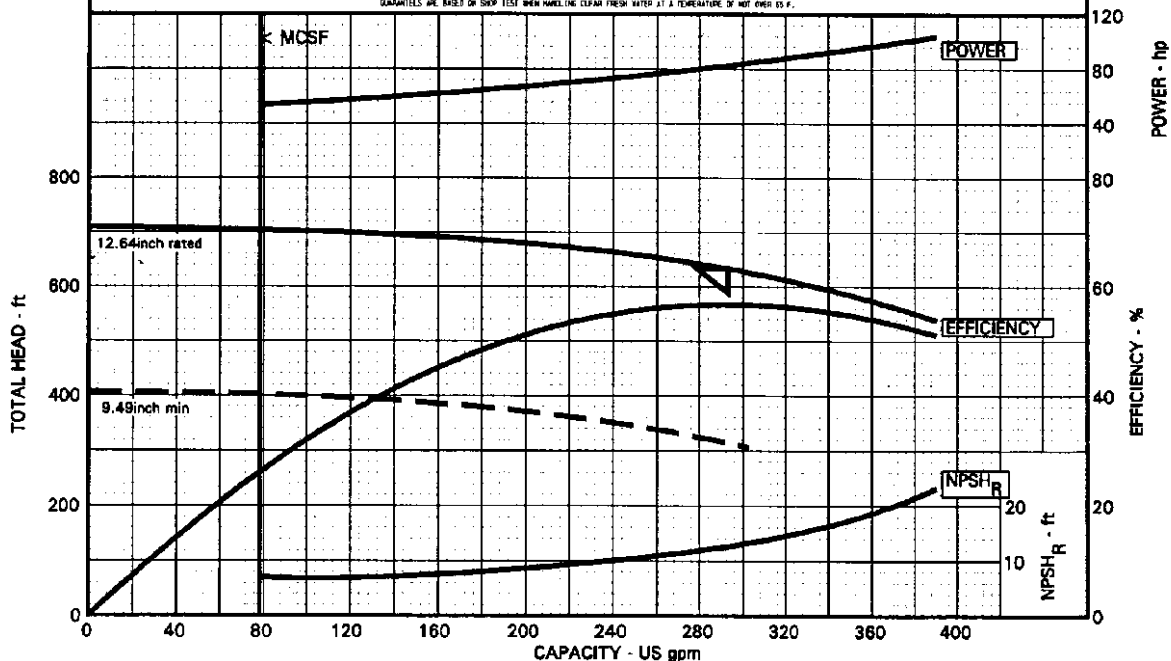


FIGURE 2 Typical centrifugal pump characteristic curves versus flow rate or capacity. ( $m^3/h = 0.277 \times \text{gpm}$ ;  $m = 0.305 \times \text{ft}$ ;  $kW = 0.746 \times \text{hp}$ ) (Flowserve Corporation)

- Will the pulsating flow of a piston pump be detrimental to system operation? Will a pulsation dampener take care of this problem?
- Is the liquid clean enough to avoid premature wear on pistons and cylinders?

For high flow and high head combinations, a multi-stage centrifugal pump can be used. Various designs of this type of pump are available with a wide range of prices reflecting special designs for a whole range of applications (high temperature, cryogenic, water, hydrocarbon, and so on).

**Low Flow with Precise Flow Adjustment Ability** For low-flow applications where accurate flow metering is necessary, a proportioning pump is appropriate. This type of pump can also be provided with variable flow capability. Certain types of gear, plunger, and diaphragm pumps can also be used in combination with a variable speed drive for flow rate regulation.

**Low Available Net Positive Suction Head** If the available net position suction head (*NPSHA*) is low, specially designed centrifugal pumps can be considered. Depending upon how low the *NPSHA* is, either a horizontal end suction with a suction inducer or a horizontal double suction arrangement may be applied. A vertical turbine pump may also be used, either immersed in the process fluid (possibly in a tank or vessel) or in a specially designed vessel (known as a suction can) that can be installed below grade to increase the *NPSHA*.

**Code and Industry Standard Requirements** The design, construction, rating, and testing of most pumps used in refining and chemical industries are governed by standards such as API (American Petroleum Institute), ASME (American Society of Mechanical Engineers), the Hydraulic Institute, NFPA (National Fire Protection Association), PIP (Process Industry Practices), ISO (International Organization for Standardization) and various other international standards. The severity of the service in which the pump will be applied, as well as the location of the plant, will determine which industry standard (or standards) will be used, if any.

In the case of a fire pump service, NFPA compliance might be mandatory to meet the user's insurance company requirements. If a pump will be installed in an oil refinery or chemical plant, either API or ASME standards will be applied depending on the severity of the service and client preferences. International standards such as DIN (German), BS (British), JIS (Japanese), or ISO can also be used. These standards are intended to provide a pump with a level of quality to match the needs and expectations of the end user of the equipment. It is obvious that the quality requirement for an emergency feed water pump in a nuclear power plant needs to be much more stringent than a potable water booster pump in an office building. The quality issues covered by these codes/standards ranges from detailed design issues to inspection and performance testing requirements.

**Fluid Characteristics** Fluid characteristics such as viscosity, density, vapor pressure, volatility, chemical stability, solid content, and entrained gases are important factors to be considered for proper pump selection. Pumps are available to handle a full range of fluid types. A positive displacement progressing cavity pump can be used to pump toothpaste, peanut butter and shampoo, but it will not usually be a good choice for pumping water or gasoline. A rotary, variable displacement piston pump is a good choice for a hydraulic control system, but not for a potable water application. A rotary sliding vane pump can be successfully applied for pumping hot asphalt and for limited application in a lube oil system.

Making the best pump selection for a certain fluid application is often difficult. Previous successful experience is usually the best guideline for proper pump selection. This information can be obtained from end users, from process licensors, and from pump manufacturers. Recommendations from all of these sources should be carefully considered.

**Pump Materials** Material selection is affected both by the pumped fluid and the environment. Resistance to corrosion and erosion are of prime importance. The engineer must

determine which material is most suitable and economical for a particular service. This requires that an evaluation be made comparing the more expensive longer life material to a less expensive material, which may provide a shorter pump life. Requirements such as continuous or intermittent operation, critical or non-critical service and plant life cycle should be considered when selecting materials.

Pumps are commonly available in cast iron, ductile iron, bronze, carbon steel, alloy steels, and in some cases composite materials or special alloys such as Monel, Hastelloy, or Titanium. In addition to the importance of pump design life, safety must also be considered when selecting materials. Cast iron construction is not used for pressure casing parts of pumps that are to handle flammable or hazardous liquids because cast iron is brittle and subject to fracture when thermally shocked. For these services, pressure-casing parts must be high strength ductile materials such as carbon or alloy steel.

**Driver Selection** The choice of driver type for a pumping service is as important as the pump selection. Factors that affect the driver choice are capital cost, driver type availability, operating reliability and the availability and cost of utilities.

Constant speed electric motors are most economical when only the first cost is considered. Often there is excess steam available within a facility that, when compared to the cost of electricity, will justify the extra cost of a steam turbine. Reliability requirements may necessitate the use of both a steam driven main pump and an electric motor driven back-up pump. In the case of firewater pumps, a battery-start, diesel-fueled internal combustion engine is needed to be completely independent of plant utilities. More expensive variable speed electric motors can sometimes be justified if the pump is operated well below its design conditions and there is the potential for significant savings in power.

There are other factors that should be considered when selecting the pump driver. The capital cost as well as the installation cost is more expensive for a steam turbine due to required piping. Steam turbines also require more maintenance during plant life, which may be undesirable to the owner. Selection based on past proven performance and selection to match existing plant equipment to minimize spare part inventory is a common consideration.

Air-operated diaphragm-type pumps are available in relatively small capacities, and these can be particularly effective in hazardous area classifications where use of electric motors may be undesirable.

**Other Equipment Supply Decisions** For both technical and commercial reasons, the purchaser may decide to purchase the pump/driver combination in various ways.

The pump and driver may be purchased separately. This may be advantageous if either the pump or driver (but not both) can be purchased locally. This will save shipping costs and possibly allow the purchaser to meet client requirements for locally manufactured content for a project. Separate purchase of drives on large capital projects can also lead to quantity price discounts and limited spare part inventories.

The purchaser must consider the risk associated with the separate purchase of the pump and driver. Equipment installation and alignment problems (with resulting start-up delay) are more probable than when the pump vendor takes single source responsibility for the purchase and skid mounting of all components.

If the decision is made to purchase the driver separately from the pump, the pump manufacturer can provide the equipment for block mounting or provide a skid on which the driver can be installed in the field. Either way, additional shop inspection is recommended to verify dimensions for field interface. It should be noted that pump manufacturers may purchase a high volume of electric motors and obtain greater discounts than most operating companies and engineering contractors.

## **PUMP BID REQUISITION**

---

It is obviously necessary to fully define the scope of supply for the desired piece of equipment. To do so requires the right amount of documentation provided by the purchaser (no more, no less) to match the type of equipment being purchased. This is easier said than

done, but the engineer needs to be conscious of the fact that a bid requisition package should be clear and concise as possible. One industry joke relates the cost of a piece of equipment to the weight of the paper included in the bid requisition.

**Requisition** A bid requisition is a document that requests a vendor or series of vendors provide a quote for a specified item. This can also be called an inquiry or request for quotation or simply an RFQ.

The bid requisition can be as simple as a one-page listing of the pump requirements. It can also be a document that incorporates data sheets, technical specifications, shipping specifications, purchasing terms and conditions, vendor drawing requirements, and any other document that will help define the full requirements of the intended purchase. A fully detailed requisition for a complicated pumping service might include over 100 pages of requirements.

As a minimum, the requisition must include a clear scope of supply, applicable specifications and data sheets, and commercial terms and conditions. In addition, the requisition can be used to specify additional requirements that have not been adequately addressed in other documents.

**Commercial Terms and Conditions** The requisition should include the following commercial terms and conditions:

- Name of buyer, place to which proposals must be delivered, information on ownership of documents, time allotted for submission of bids, governing laws and regulations
- Location of plant site
- Site storage conditions and anticipated length of storage (preparation requirements)
- Schedule for submittal of drawings/documentation, and pump delivery
- Guaranty/warranty requirements
- Instruction on minimum information to include in the proposal, number of copies that vendor must provide, status of alternative offerings, and a statement on the owners right to accept or reject bids that are not in accordance with the bid package
- Acceptable terms of payment
- Method of transportation to site that establishes the vendor's responsibility. If the vendor will not be responsible for providing shipping, he must be requested to provide enough information in the quote for others to estimate shipping costs
- Customer shop inspection requirements
- Any penalty or bonus related to late or early shipping, and so on

The list of specifications and data sheets must include document name or description, document number, revision number, and revision date. This will provide a record of what documents have been sent to a vendor. See Figure 3 for an example of a requisition format that might be used to request bids for pumps in an oil refinery or petrochemical plant.

**Pump Technical Specification** As discussed previously, there are many different designs of pumps that can be purchased. Engineering and operating companies may have standard technical specifications for all categories of equipment that are commonly purchased. When a pump service is being prepared for bids, a technical specification can be used in standard form, or updated to incorporate special requirements based on client or other project specific needs.

A technical specification is usually written to cover a wide range of equipment within a given category. Because many variations exist within any equipment category, the technical specification is usually written to be applicable to this range of equipment. Data sheets may be used to provide the specific requirements not covered in the technical specification.

Most technical specifications are written as performance specifications rather than design specifications. Care must be exercised to ensure that the pump manufacturer (not

REQUISITION					
Type of Order:		Requisition Number		Rev. No.	
Client:					
Plant Location:		Technical Review Required:			
Level of Technical Data Sufficient for:		P.O. #:			
Vendor Inquiry Place Purchase Order		Vendor:			
Line Ref	Item No.	Quantity	Material & Attachment Description	Budget	
				Unit	Extension
Originator		Ext.	Approved By:	Total Budget (US)	

FIGURE 3 Example of a requisition format

the purchaser) is responsible for the actual equipment design. If design requirements rather than performance requirements are specified, the vendor may claim that he is not responsible when performance requirements are not met. Care must be taken to assure that the equipment selected is from qualified vendors with proven design experience in similar applications. The purchaser must resist the temptation to force the vendor to modify a proven design and build a pump with which the vendor does not have proven experience.

As a minimum, a technical specification must list the following:

1. Industry codes and standards to which the pump must be designed, constructed, and tested. It is also possible to create a technical specification that stands alone and does

not reference (or minimally references) codes and standards. This stand-alone technical specification will require a more thorough listing of needed requirements than one that references common design, fabrication, and testing standards.

2. A list of desired deviations and preferences from the main technical standards used to help define the pump requirements.
3. A definition of any technical terms used in the specifications that are not defined in referenced standards. This will help prevent misunderstandings between the purchaser and pump vendors.
4. A list of documents to be submitted by the successful bidder, both with the quotation and after the order is placed.

**Pump Data Sheets** As stated previously, a data sheet is used to list specific requirements for each individual pump service. These requirements are not general enough to be listed in the technical specification. Each pump service requires its own data sheet. As a minimum, the following items must be included on the data sheets for each service:

1. Pump name and item number
2. All required system design conditions and pump performance values needed to fully define the pump operating requirements, including any known turndown, start-up, or upset conditions
3. Materials of construction (unless the vendor is free to recommend standard materials)
4. All accessory requirements (unless the vendor is free to offer the standard selections) such as driver, coupling, seal, and packaging needs
5. Utility conditions available
6. Intended site location and annual environmental conditions in this location
7. Electrical hazardous area classification
8. Instrumentation and control requirements (usually out of the vendors scope)
9. Noise requirements
10. Any specific preferences that deviate from requirements of the technical specifications
11. Inspection and testing requirements

In addition, the vendor should be advised to fill in the applicable blanks in the data sheet and submit the proposal. The manufacturer's data will help define the offering. See Figures 4a to 4e for the API-610, 8th edition, data sheet.

**Other Requisition Documents and Requirements** A purchaser may include many additional options in the bid requisition. These requirements may be included in the requisition narrative or data sheets. Some possible options are addressed in the following paragraphs.

**Alternates** It is extremely difficult for a specification to cover all possible pumps offered by various manufacturers. In addition, the pump industry constantly updates their products due to competition and revisions to industry standards. Because of this, it is good practice to allow manufacturers to offer alternatives to the specified pumping equipment. This allows manufacturers to present their best offerings and gives the purchaser the advantage of obtaining commercially and technically attractive alternate offerings. However, the choice of whether to accept an alternative is retained by the purchaser.

**Energy Evaluation** The purchaser may choose to include operating costs in the equipment evaluation. If so, the vendor needs to be informed of this requirement so the most

**API 610, 8TH EDITION**  
**CENTRIFUGAL PUMP DATA SHEET**  
**SI UNITS / ISO STANDARDS (1.2.2)**

JOB NO. \_\_\_\_\_ ITEM NO. \_\_\_\_\_  
 REQ / SPEC NO. \_\_\_\_\_  
 PURCH ORDER NO. \_\_\_\_\_ DATE \_\_\_\_\_  
 INQUIRY NO. \_\_\_\_\_ BY \_\_\_\_\_  
 REVISION \_\_\_\_\_ DATE \_\_\_\_\_

1	APPLICABLE TO: <input type="radio"/> PROPOSAL <input type="radio"/> PURCHASE <input checked="" type="radio"/> AS BUILT	
2	FOR _____	UNIT _____
3	SITE _____	SERVICE _____
4	NO. REQ. _____ PUMP SIZE _____	TYPE _____ NO. STAGES _____
5	MANUFACTURER _____ MODEL _____	SERIAL NO. _____
6	NOTE: <input type="radio"/> INDICATES INFORMATION COMPLETED BY PURCHASER <input type="checkbox"/> BY MANUFACTURER <input checked="" type="checkbox"/> BY MANUFACTURER OR PURCHASER	
7	<b>GENERAL (3.1.1)</b>	
8	PUMPS TO OPERATE IN (PARALLEL) _____ NO. MOTOR DRIVEN _____ NO. TURBINE DRIVEN _____	
9	(SERIES) WITH _____ PUMP ITEM NO. _____ PUMP ITEM NO. _____	
10	GEAR ITEM NO. _____ MOTOR ITEM NO. _____ TURBINE ITEM NO. _____	
11	GEAR PROVIDED BY _____ MOTOR PROVIDED BY _____ TURBINE PROVIDED BY _____	
12	GEAR MOUNTED BY _____ MOTOR MOUNTED BY _____ TURBINE MOUNTED BY _____	
13	GEAR DATA SHEET NO. _____ MOTOR DATA SHEET NO. _____ TURBINE DATA SHEET NO. _____	
14	<b>OPERATING CONDITIONS</b>	<b>SITE AND UTILITY DATA (CONT.)</b>
15	<input type="radio"/> CAPACITY, NORMAL _____ (m <sup>3</sup> /h) RATED _____ (m <sup>3</sup> /h)	WATER SOURCE _____
16	OTHER _____	CHLORIDE CONCENTRATION (PPM) _____ (3.5.2.6)
17	<input type="radio"/> SUCTION PRESSURE MAX/RATED _____ (kPa)	INSTRUMENT AIR: MAX/MIN PRESS _____ (kPa)
18	<input type="radio"/> DISCHARGE PRESSURE _____ (kPa)	<b>LIQUID</b>
19	<input type="radio"/> DIFFERENTIAL PRESSURE _____ (kPa)	<input type="radio"/> TYPE/NAME OF LIQUID _____
20	<input type="radio"/> DIFFERENTIAL HEAD (m) NPSHA (m)	<input type="radio"/> PUMPING TEMPERATURE:
21	<input type="radio"/> PROCESS VARIATIONS _____ (3.1.2)	NORMAL _____ (°C) MAX _____ (°C) MIN _____ (°C)
22	<input type="radio"/> STARTING CONDITIONS _____ (3.1.3)	<input type="radio"/> VAPOR PRESSURE _____ (kPa abs) @ _____ (°C)
23	SERVICE: <input type="radio"/> CONTINUOUS <input type="radio"/> INTERMITTENT (START/DAY) _____	<input type="radio"/> RELATIVE DENSITY (SPECIFIC GRAVITY):
24	<input type="radio"/> PARALLEL OPERATION REQ'D (2.1.11)	NORMAL _____ MAX _____ MIN _____
25	<b>SITE AND UTILITY DATA</b>	<input type="radio"/> SPECIFIC HEAT, Cp _____ (kJ/kg °C)
26	LOCATION: (2.1.29)	<input type="radio"/> VISCOSITY _____ (cP) @ _____ (°C)
27	<input type="radio"/> INDOOR <input type="radio"/> HEATED <input type="radio"/> UNDER ROOF	<input type="radio"/> MAX VISCOSITY _____ (cP)
28	<input type="radio"/> OUTDOOR <input type="radio"/> UNHEATED <input type="radio"/> PARTIAL SIDES	<input type="radio"/> CORROSIVE/EROSIVE AGENT _____ (2.11.1.8)
29	<input type="radio"/> GRADE <input type="radio"/> MEZZANINE <input type="radio"/>	<input type="radio"/> CHLORIDE CONCENTRATION (PPM) _____ (3.5.2.6)
30	<input type="radio"/> ELECTRICAL AREA CLASSIFICATION (2.1.22 / 3.1.5)	<input type="radio"/> H <sub>2</sub> S CONCENTRATION (PPM) _____ (2.11.1.11)
31	CL _____ GR _____ DIV _____	LIQUID (2.1.3) <input type="radio"/> HAZARDOUS <input type="radio"/> FLAMMABLE
32	<input type="radio"/> WINTERIZATION REQ'D <input type="radio"/> TROPICALIZATION REQ'D	<input type="radio"/> OTHER _____
33	SITE DATA (2.1.29)	<b>PERFORMANCE</b>
34	<input type="radio"/> ALTITUDE (m) BAROMETER _____ (kPa abs)	PROPOSAL CURVE NO. _____ <input type="checkbox"/> RPM _____
35	<input type="radio"/> RANGE OF AMBIENT TEMPS: MIN/MAX _____ (°C)	<input type="checkbox"/> IMPELLER DIA RATED _____ MAX _____ MIN _____ (mm)
36	<input type="radio"/> RELATIVE HUMIDITY: MIN/MAX _____ (%)	<input type="checkbox"/> RATED POWER _____ (BHP) EFFICIENCY _____ (%)
37	UNUSUAL CONDITIONS (2.1.23) <input type="radio"/> DUST <input type="radio"/> FUMES	<input type="checkbox"/> MINIMUM CONTINUOUS FLOW:
38	<input type="radio"/> OTHER _____	THERMAL _____ (m <sup>3</sup> /h) STABLE _____ (m <sup>3</sup> /h)
39	<input type="radio"/> UTILITY CONDITIONS:	<input type="checkbox"/> PREFERRED OPERATING REGION _____ TO _____ (m <sup>3</sup> /h)
40	STEAM: DRIVERS _____ HEATING _____	<input type="checkbox"/> ALLOWABLE OPERATING REGION _____ TO _____ (m <sup>3</sup> /h)
41	MIN _____ (kPa) _____ (°C) _____ (kPa) _____ (°C)	<input type="checkbox"/> MAX HEAD @ RATED IMPELLER _____ (m)
42	MAX _____ (kPa) _____ (°C) _____ (kPa) _____ (°C)	<input type="checkbox"/> MAX POWER @ RATED IMPELLER _____ (kW)
43	ELECTRICITY: DRIVERS _____ HEATING _____ CONTROL _____ SHUTDOWN _____	<input type="checkbox"/> NPSH REQUIRED AT RATED CAP _____ (m) (2.1.8)
44	VOLTAGE _____	<input checked="" type="checkbox"/> SUCTION SPECIFIC SPEED _____ (2.1.9)
45	HERTZ _____	<input type="radio"/> MAX SOUND PRESS. LEVEL REQ'D _____ (dBA) (2.1.14)
46	PHASE _____	<input type="checkbox"/> EST MAX SOUND PRESS. LEVEL _____ (dBA) (2.1.14)
47	COOLING WATER: (2.1.17)	REMARKS _____
48	TEMP INLET _____ (°C) MAX RETURN _____ (°C)	
49	PRESS NORMAL _____ (kPa) DESIGN _____ (kPa)	
50	MIN RETURN _____ (kPa) MAX ALLOW DP _____ (kPa)	
51		

FIGURE 4A API 610 data sheet, page 1 of 5 (Courtesy American Petroleum Institute)

attractive proposal can be offered. In this case, the overall equipment cost will be a combination of first cost and the differential cost of energy used over a specified period of time.

This evaluation is often calculated to a cost per horsepower penalty that includes all economic factors. If so, the vendor must be informed of the present worth payback time for this analysis (such as three years), cost of a unit of energy, and the number of hours per





**API 610, 8TH EDITION**  
**CENTRIFUGAL PUMP DATA SHEET**  
**SI UNITS / ISO STANDARDS (1.2.2)**

JOB NO. \_\_\_\_\_ ITEM NO. \_\_\_\_\_  
 REQ / SPEC NO. \_\_\_\_\_  
 PURCH ORDER NO. \_\_\_\_\_ DATE \_\_\_\_\_  
 INQUIRY NO. \_\_\_\_\_ BY \_\_\_\_\_  
 REVISION \_\_\_\_\_ DATE \_\_\_\_\_

1	<b>BEARINGS AND LUBRICATION (cont)</b>	<b>MECHANICAL SEAL OR PACKING (CONT)</b>
2	<input checked="" type="checkbox"/> OIL HEATER REQ'D <input type="checkbox"/> ELECTRIC <input type="checkbox"/> STEAM (2.9.2.9.5.2.6.3)	<input type="checkbox"/> VAPOR PRESSURE _____ (kPa abs) @ _____ (°C)
3	<input type="checkbox"/> OIL PRESS TO BE GREATER THAN COOLANT PRESS (5.2.6.2.b)	<input type="checkbox"/> HAZARDOUS <input type="checkbox"/> FLAMMABLE <input type="checkbox"/> OTHER _____
4	REMARKS _____	<input type="checkbox"/> FLOW RATE MAX/MIN _____ / _____ (m <sup>3</sup> /h)
5	_____	<input type="checkbox"/> PRESSURE REQUIRED MAX/MIN _____ / _____ (kPa)
6	_____	<input checked="" type="checkbox"/> TEMPERATURE REQUIRED MAX/MIN _____ / _____ (°C)
7	<b>MECHANICAL SEAL OR PACKING</b>	<b>QUENCH FLUID:</b>
8	SEAL DATA: (2.7.2)	<input type="checkbox"/> NAME OF FLUID _____
9	<input type="checkbox"/> SEE ATTACHED API-682 DATA SHEET	<input type="checkbox"/> FLOW RATE _____ (m <sup>3</sup> /h)
10	<input type="checkbox"/> NON-API 682 SEAL (2.7.2)	<b>SEAL FLUSH PIPING: (2.7.3.19 AND APPENDIX D)</b>
11	<input type="checkbox"/> APPENDIX H SEAL CODE _____ (2.11.1.1)	<input type="checkbox"/> SEAL FLUSH PIPING PLAN _____
12	<input checked="" type="checkbox"/> SEAL MANUFACTURER _____	<input checked="" type="checkbox"/> TUBING <input checked="" type="checkbox"/> CARBON STEEL
13	<input checked="" type="checkbox"/> SIZE AND TYPE _____ / _____	<input checked="" type="checkbox"/> PIPE <input checked="" type="checkbox"/> STAINLESS STEEL
14	<input checked="" type="checkbox"/> MANUFACTURER CODE _____	<input type="checkbox"/> AUXILIARY FLUSH PLAN _____
15	SEAL CHAMBER DATA: (2.1.6.2.1.7)	<input checked="" type="checkbox"/> TUBING <input checked="" type="checkbox"/> CARBON STEEL
16	<input checked="" type="checkbox"/> TEMPERATURE _____ (°C)	<input checked="" type="checkbox"/> PIPE <input checked="" type="checkbox"/> STAINLESS STEEL
17	<input checked="" type="checkbox"/> PRESSURE _____ (kPa)	<input type="checkbox"/> PIPING ASSEMBLY: (3.5.2.10.1)
18	<input checked="" type="checkbox"/> FLOW _____ (m <sup>3</sup> /h)	<input checked="" type="checkbox"/> THREADED <input type="checkbox"/> UNIONS <input checked="" type="checkbox"/> SOCKET WELDED
19	<input type="checkbox"/> SEAL CHAMBER SIZE (TABLE 2.3)	<input checked="" type="checkbox"/> FLANGED <input checked="" type="checkbox"/> TUBE TYPE FITTINGS
20	<input type="checkbox"/> TOTAL LENGTH _____ (mm) <input type="checkbox"/> CLEAR LENGTH _____ (mm)	<input checked="" type="checkbox"/> PRESSURE SWITCH (PLAN 52/53) TYPE _____
21	SEAL CONSTRUCTION:	<input type="checkbox"/> PRESSURE GAUGE (PLAN 52/53)
22	<input type="checkbox"/> SLEEVE MATERIAL _____	<input checked="" type="checkbox"/> LEVEL SWITCH (PLAN 52/53) TYPE _____
23	<input type="checkbox"/> GLAND MATERIAL _____	<input type="checkbox"/> LEVEL GAUGE (PLAN 52/53)
24	<input type="checkbox"/> AUX SEAL DEVICE (2.7.3.20)	<input type="checkbox"/> TEMP INDICATOR (PLANS 21, 22, 23, 32, 41)
25	<input checked="" type="checkbox"/> JACKET REQUIRED (2.7.3.17)	<input type="checkbox"/> HEAT EXCHANGER (PLAN 52/53)
26	GLAND TAPS: (2.7.3.14)	REMARKS _____
27	<input checked="" type="checkbox"/> FLUSH (F) <input checked="" type="checkbox"/> DRAIN (D) <input type="checkbox"/> BARRIER/BUFFER(B)	
28	<input checked="" type="checkbox"/> QUENCH (Q) <input checked="" type="checkbox"/> COOLING (C) <input checked="" type="checkbox"/> LUBRICATION (G)	
29	<input checked="" type="checkbox"/> HEATING (H) <input checked="" type="checkbox"/> LEAKAGE <input checked="" type="checkbox"/> PUMPED FLUID (P)	
30	<input type="checkbox"/> BALANCE FLUID (E) <input checked="" type="checkbox"/> EXTERNAL FLUID INJECTION (X)	<b>PACKING DATA: (APPENDIX C)</b>
31	SEAL FLUIDS REQUIREMENT AND AVAILABLE FLUSH LIQUID:	MANUFACTURER _____
32	NOTE: IF FLUSH LIQUID IS PUMPAGE LIQUID (AS IN FLUSH PIPING	TYPE _____
33	PLANS 11 TO 41), FOLLOWING FLUSH LIQUID DATA IS NOT REQ'D.	SIZE _____ NO. OF RINGS _____
34	<input type="checkbox"/> SUPPLY TEMPERATURE MAX/MIN _____ / _____ (°C)	<input type="checkbox"/> PACKING INJECTION REQUIRED
35	<input type="checkbox"/> RELATIVE DENSITY (SPECIFIC GRAVITY) _____ @ _____ (°C)	<input type="checkbox"/> FLOW _____ (m <sup>3</sup> /h) @ _____ (°C)
36	<input type="checkbox"/> NAME OF FLUID _____	<input type="checkbox"/> LANTERN RING
37	<input type="checkbox"/> SPECIFIC HEAT, Cp _____ (kJ/kg °C)	<b>STEAM AND COOLING WATER PIPING</b>
38	<input type="checkbox"/> VAPOR PRESSURE _____ (kPa abs) @ _____ (°C)	<input checked="" type="checkbox"/> COOLING WATER PIPING PLAN _____ (3.5.4.1)
39	<input type="checkbox"/> HAZARDOUS <input type="checkbox"/> FLAMMABLE <input type="checkbox"/> OTHER _____	<input type="checkbox"/> COOLING WATER REQUIREMENTS
40	<input type="checkbox"/> FLOW RATE MAX/MIN _____ / _____ (m <sup>3</sup> /h)	SEAL JACKET/BRG HSG _____ (m <sup>3</sup> /h) @ _____ (kPa)
41	<input type="checkbox"/> PRESSURE REQUIRED MAX/MIN _____ / _____ (kPa)	SEAL HEAT EXCHANGER _____ (m <sup>3</sup> /h) @ _____ (kPa)
42	<input type="checkbox"/> TEMPERATURE REQUIRED MAX/MIN _____ / _____ (°C)	QUENCH _____ (m <sup>3</sup> /h) @ _____ (kPa)
43	<b>BARRIER/BUFFER FLUID (2.7.3.21):</b>	TOTAL COOLING WATER _____ (m <sup>3</sup> /h)
44	<input type="checkbox"/> SUPPLY TEMPERATURE MAX/MIN _____ / _____ (°C)	<input type="checkbox"/> STEAM PIPING: <input type="checkbox"/> TUBING <input type="checkbox"/> PIPE
45	<input type="checkbox"/> RELATIVE DENSITY (SPECIFIC GRAVITY) _____ @ _____ (°C)	REMARKS _____
46	<input type="checkbox"/> NAME OF FLUID _____	
47		

FIGURE 4C API 610 data sheet, page 3 of 5 (Courtesy American Petroleum Institute)

been limited to the cost of the initial capital equipment plus some evaluation for the cost of energy. LCC evaluations include the following major cost categories:

- Purchase price of the pump set (including pump(s), motor, motor starter, and so on)
- Placement cost (includes installation costs such as foundations, electrical installation, piping, isolation valves, and so on)
- Energy cost (usually electricity because most pumps are driven by electric motors)

**API 610, 8TH EDITION**  
**CENTRIFUGAL PUMP DATA SHEET**  
**SI UNITS / ISO STANDARDS (1.2.2)**

PAGE 4 OF 5

JOB NO. \_\_\_\_\_ ITEM NO. \_\_\_\_\_  
 REQ / SPEC NO. \_\_\_\_\_ DATE \_\_\_\_\_  
 PURCH ORDER NO. \_\_\_\_\_ BY \_\_\_\_\_  
 INQUIRY NO. \_\_\_\_\_ DATE \_\_\_\_\_  
 REVISION \_\_\_\_\_

<p>1 <b>INSTRUMENTATION</b></p> <p>2 <b>VIBRATION:</b></p> <p>3 <input type="radio"/> NONCONTACTING (API 670)    <input type="radio"/> TRANSDUCER</p> <p>4 <input type="radio"/> PROVISION FOR MOUNTING ONLY (2.9.2.11)</p> <p>5 <input type="radio"/> FLAT SURFACE REQ'D (2.9.2.12)</p> <p>6 <input type="radio"/> SEE ATTACHED API-670 DATA SHEET</p> <p>7 <input type="radio"/> MONITORS AND CABLES (3.4.3.3)</p> <p>8 REMARKS _____</p> <p>9 _____</p> <p>10 _____</p> <p>11 <b>TEMPERATURE AND PRESSURE:</b></p> <p>12 <input checked="" type="checkbox"/> RADIAL BRG METAL TEMP    <input type="checkbox"/> THRUST BRG METAL TEMP</p> <p>13 <input type="radio"/> PROVISION FOR INSTRUMENTS ONLY</p> <p>14 <input type="radio"/> SEE ATTACHED API-670 DATA SHEET</p> <p>15 <input type="radio"/> TEMP GAUGES (WITH THERMOWELLS) (3.4.1.3)</p> <p>16 OTHER _____</p> <p>17 <input type="radio"/> PRESSURE GAUGE TYPE (3.4.2.2) _____</p> <p>18 LOCATION _____</p> <p>19 REMARKS _____</p> <p>20 _____</p> <p>21 _____</p> <p>22 <b>SPARE PARTS (TABLE 6.1)</b></p> <p>23 <input type="radio"/> START-UP                      <input type="radio"/> NORMAL MAINTENANCE</p> <p>24 <input type="radio"/> SPECIFY _____</p> <p>25 _____</p> <p>26 _____</p> <p>27 <b>MOTOR DRIVE (3.1.5)</b></p> <p>28 <input checked="" type="checkbox"/> MANUFACTURER _____</p> <p>29 <input type="checkbox"/> _____ (kW)    <input type="checkbox"/> _____ (RPM)</p> <p>30 <input type="checkbox"/> HORIZONTAL                      <input checked="" type="checkbox"/> VERTICAL</p> <p>31 <input type="checkbox"/> FRAME _____</p> <p>32 <input checked="" type="checkbox"/> SERVICE FACTOR _____</p> <p>33 <input checked="" type="checkbox"/> VOLTS/PHASE/HERTZ _____ / _____ / _____</p> <p>34 <input type="radio"/> TYPE _____</p> <p>35 <input checked="" type="checkbox"/> ENCLOSURE _____</p> <p>36 <input type="radio"/> MINIMUM STARTING VOLTAGE (3.1.6) _____</p> <p>37 <input type="radio"/> TEMPERATURE RISE _____</p> <p>38 <input checked="" type="checkbox"/> FULL LOAD AMPS _____</p> <p>39 <input checked="" type="checkbox"/> LOCKED ROTOR AMPS _____</p> <p>40 <input checked="" type="checkbox"/> INSULATION _____</p> <p>41 <input checked="" type="checkbox"/> STARTING METHOD _____</p> <p>42 <input type="checkbox"/> LUBE _____</p> <p>43 <input type="checkbox"/> VERTICAL THRUST CAPACITY</p> <p>44 UP _____ (N) DOWN _____ (N)</p> <p>45 <b>BEARINGS (TYPE / NUMBER):</b></p> <p>46 <input type="checkbox"/> RADIAL _____ / _____</p> <p>47 <input type="checkbox"/> THRUST _____ / _____</p> <p>48 _____</p>	<p><b>MOTOR DRIVE (cont) (3.1.6)</b></p> <p>REMARKS _____</p> <p>_____</p> <p>_____</p> <p><b>SURFACE PREPARATION AND PAINT</b></p> <p><input type="radio"/> MANUFACTURER'S STANDARD</p> <p><input type="radio"/> OTHER (SEE BELOW)</p> <p><b>PUMP:</b></p> <p><input type="radio"/> PUMP SURFACE PREPARATION _____</p> <p><input type="radio"/> PRIMER _____</p> <p><input type="radio"/> FINISH COAT _____</p> <p><b>BASEPLATE: (3.3.18)</b></p> <p><input type="radio"/> BASEPLATE SURFACE PREPARATION _____</p> <p><input type="radio"/> PRIMER _____</p> <p><input type="radio"/> FINISH COAT _____</p> <p><b>SHIPMENT: (4.4.1)</b></p> <p><input type="radio"/> DOMESTIC    <input type="radio"/> EXPORT    <input type="radio"/> EXPORT BOXING REQUIRED</p> <p><input type="radio"/> OUTDOOR STORAGE MORE THAN 8 MONTHS</p> <p><b>SPARE ROTOR ASSEMBLY PACKAGED FOR:</b></p> <p><input type="radio"/> HORIZONTAL STORAGE    <input type="radio"/> VERTICAL STORAGE</p> <p><input type="radio"/> TYPE OF SHIPPING PREPARATION _____</p> <p>REMARKS _____</p> <p>_____</p> <p>_____</p> <p><input type="checkbox"/> <b>WEIGHTS</b></p> <p><b>MOTOR DRIVEN:</b></p> <p>WEIGHT OF PUMP (kg) _____</p> <p>WEIGHT OF BASEPLATE (kg) _____</p> <p>WEIGHT OF MOTOR (kg) _____</p> <p>WEIGHT OF GEAR (kg) _____</p> <p>TOTAL WEIGHT (kg) _____</p> <p><b>TURBINE DRIVEN:</b></p> <p>WEIGHT OF BASEPLATE (kg) _____</p> <p>WEIGHT OF TURBINE (kg) _____</p> <p>WEIGHT OF GEAR (kg) _____</p> <p>TOTAL WEIGHT (kg) _____</p> <p>REMARKS _____</p> <p>_____</p> <p>_____</p> <p><b>OTHER PURCHASER REQUIREMENTS</b></p> <p><input type="radio"/> COORDINATION MEETING REQUIRED (6.1.3)</p> <p><input type="radio"/> REVIEW FOUNDATION DRAWINGS (2.1.27)</p> <p><input type="radio"/> REVIEW PIPING DRAWINGS</p> <p><input type="radio"/> OBSERVE PIPING CHECKS</p> <p><input type="radio"/> OBSERVE INITIAL ALIGNMENT CHECK</p> <p><input type="radio"/> CHECK ALIGNMENT AT OPERATING TEMPERATURE</p> <p><input type="radio"/> CONNECTION DESIGN APPROVAL (2.11.3.5.4)</p>
--	---

FIGURE 4D API 610 data sheets, page 4 of 5 (Courtesy American Petroleum Institute)

- Auxiliary services (includes operating costs such as cooling water, steam heating, centralized oil lubrication systems, and so on)
- Maintenance (includes routine servicing and unplanned repairs)
- Potential loss of income due to unplanned downtime (sometimes neglected if a spare pump is included in purchase price)
- Disposal (to dispose of the equipment, in an environmentally responsibly way)

**API 610, 8TH EDITION  
CENTRIFUGAL PUMP DATA SHEET  
SI UNITS / ISO STANDARDS (1.2.2)**

JOB NO. \_\_\_\_\_ ITEM NO. \_\_\_\_\_  
 REQ / SPEC NO. \_\_\_\_\_  
 PURCH ORDER NO. \_\_\_\_\_ DATE \_\_\_\_\_  
 INQUIRY NO. \_\_\_\_\_ BY \_\_\_\_\_  
 REVISION \_\_\_\_\_ DATE \_\_\_\_\_

<p>1 <b>OTHER PURCHASER REQUIREMENTS (cont)</b></p> <p>2 <input type="checkbox"/> RIGGING DEVICE REQ'D FOR TYPE OH3 PUMP (5.1.2.7)</p> <p>3 <input type="checkbox"/> HYDRODYNAMIC THRUST BRG SIZE REVIEW REQ'D (5.2.5.2.4)</p> <p>4 <input checked="" type="checkbox"/> LATERAL ANALYSIS REQUIRED (5.1.4.3/5.2.4.1)</p> <p>5 <input checked="" type="checkbox"/> ROTOR DYNAMIC BALANCE (5.2.4.2)</p> <p>6 <input checked="" type="checkbox"/> MOUNT SEAL RESERVOIR OFF BASEPLATE (3.5.1.4)</p> <p>7 <input checked="" type="checkbox"/> INSTALLATION LIST IN PROPOSAL (6.2.3L)</p> <p>8 <input type="checkbox"/> SPARE ROTOR VERTICAL STORAGE (5.2.9.2)</p> <p>9 <input type="checkbox"/> TORSIONAL ANALYSIS/REPORT (2.8.2.6)</p> <p>10 <input type="checkbox"/> PROGRESS REPORTS REQUIRED (6.3.4)</p> <p>11 REMARKS: _____</p> <p>12 _____</p> <p>13 _____</p>	<p><b>QA INSPECTION AND TEST (cont)</b></p> <p><b>ADDITIONAL INSPECTION REQUIRED FOR:</b></p> <p>_____ (4.2.1.3)</p> <p><input type="checkbox"/> MAG PARTICLE      <input type="checkbox"/> LIQUID PENETRANT</p> <p><input type="checkbox"/> RADIOGRAPHIC      <input type="checkbox"/> ULTRASONIC</p> <p><input type="checkbox"/> ALTERNATIVE ACCEPTANCE CRITERIA (SEE REMARKS) (4.2.2.1)</p> <p><input type="checkbox"/> HARDNESS TEST REQUIRED FOR: _____ (4.2.3.2)</p> <p><input type="checkbox"/> WETTING AGENT HYDROTEST (4.3.2.5)</p> <p><input type="checkbox"/> VENDOR SUBMIT TEST PROCEDURES (4.3.1.2/6.2.5)</p> <p><input type="checkbox"/> RECORD FINAL ASSEMBLY RUNNING CLEARANCES</p> <p><input type="checkbox"/> INSPECTION CHECK-LIST (APPENDIX N) _____ (4.1.6)</p> <p>REMARKS _____</p>																																																				
<p>14 <b>QA INSPECTION AND TEST</b></p> <p>15 <input type="checkbox"/> REVIEW VENDORS QA PROGRAM (4.1.7)</p> <p>16 <input type="checkbox"/> PERFORMANCE CURVE APPROVAL</p> <p>17 <input type="checkbox"/> SHOP INSPECTION (4.1.4)</p> <p>18 <input checked="" type="checkbox"/> TEST WITH SUBSTITUTE SEAL (4.3.3.1.2)</p> <table border="1" style="width:100%; border-collapse: collapse;"> <thead> <tr> <th style="width:60%;">TEST</th> <th style="width:10%;">NON-WIT</th> <th style="width:10%;">WIT</th> <th style="width:20%;">OBSERVE</th> </tr> </thead> <tbody> <tr><td>19 HYDROSTATIC (4.3.2)</td><td style="text-align:center"><input type="checkbox"/></td><td style="text-align:center"><input type="checkbox"/></td><td style="text-align:center"><input type="checkbox"/></td></tr> <tr><td>20 PERFORMANCE (4.3.3)</td><td style="text-align:center"><input type="checkbox"/></td><td style="text-align:center"><input type="checkbox"/></td><td style="text-align:center"><input type="checkbox"/></td></tr> <tr><td>21 NPSH (4.3.4.1)</td><td style="text-align:center"><input type="checkbox"/></td><td style="text-align:center"><input type="checkbox"/></td><td style="text-align:center"><input type="checkbox"/></td></tr> <tr><td>22 COMPLETE UNIT TEST (4.3.4.2)</td><td style="text-align:center"><input type="checkbox"/></td><td style="text-align:center"><input type="checkbox"/></td><td style="text-align:center"><input type="checkbox"/></td></tr> <tr><td>23 SOUND LEVEL TEST (4.3.4.3)</td><td style="text-align:center"><input type="checkbox"/></td><td style="text-align:center"><input type="checkbox"/></td><td style="text-align:center"><input type="checkbox"/></td></tr> <tr><td>24 <input type="checkbox"/> CLEANLINESS PRIOR TO FINAL ASSEMBLY (4.2.3.1)</td><td></td><td></td><td></td></tr> <tr><td>25 <input type="checkbox"/> NOZZLE LOAD TEST (3.3.6)</td><td style="text-align:center"><input type="checkbox"/></td><td style="text-align:center"><input type="checkbox"/></td><td style="text-align:center"><input type="checkbox"/></td></tr> <tr><td>26 <input type="checkbox"/> BRG HSG RESONANCE TEST (4.3.4.5)</td><td style="text-align:center"><input type="checkbox"/></td><td style="text-align:center"><input type="checkbox"/></td><td style="text-align:center"><input type="checkbox"/></td></tr> <tr><td>27 <input type="checkbox"/> REMOVE/INSPECT HYDRODYNAMIC BEARINGS AFTER TEST (5.2.8.5)</td><td style="text-align:center"><input type="checkbox"/></td><td style="text-align:center"><input type="checkbox"/></td><td style="text-align:center"><input type="checkbox"/></td></tr> <tr><td>28 <input type="checkbox"/> AUXILIARY EQUIPMENT TEST (4.3.4.4)</td><td style="text-align:center"><input type="checkbox"/></td><td style="text-align:center"><input type="checkbox"/></td><td style="text-align:center"><input type="checkbox"/></td></tr> <tr><td>29 _____</td><td style="text-align:center"><input type="checkbox"/></td><td style="text-align:center"><input type="checkbox"/></td><td style="text-align:center"><input type="checkbox"/></td></tr> <tr><td>30 _____</td><td style="text-align:center"><input type="checkbox"/></td><td style="text-align:center"><input type="checkbox"/></td><td style="text-align:center"><input type="checkbox"/></td></tr> </tbody> </table> <p>31 <input type="checkbox"/> MATERIAL CERTIFICATION REQUIRED (2.11.1.7)</p> <p><input type="checkbox"/> CASING      <input type="checkbox"/> IMPELLER      <input type="checkbox"/> SHAFT</p> <p><input type="checkbox"/> OTHER _____</p> <p>32 <input type="checkbox"/> CASTING REPAIR PROCEDURE APPROVAL REQ'D (2.11.2.5)</p> <p>33 <input type="checkbox"/> INSPECTION REQUIRED FOR CONNECTION WELDS (2.11.3.6)</p> <p><input type="checkbox"/> MAG PARTICLE      <input type="checkbox"/> LIQUID PENETRANT</p> <p><input type="checkbox"/> RADIOGRAPHIC      <input type="checkbox"/> ULTRASONIC</p> <p>34 <input type="checkbox"/> INSPECTION REQUIRED FOR CASTINGS (4.2.1.3)</p> <p><input type="checkbox"/> MAG PARTICLE      <input type="checkbox"/> LIQUID PENETRANT</p> <p><input type="checkbox"/> RADIOGRAPHIC      <input type="checkbox"/> ULTRASONIC</p>	TEST	NON-WIT	WIT	OBSERVE	19 HYDROSTATIC (4.3.2)	<input type="checkbox"/>	<input type="checkbox"/>	<input type="checkbox"/>	20 PERFORMANCE (4.3.3)	<input type="checkbox"/>	<input type="checkbox"/>	<input type="checkbox"/>	21 NPSH (4.3.4.1)	<input type="checkbox"/>	<input type="checkbox"/>	<input type="checkbox"/>	22 COMPLETE UNIT TEST (4.3.4.2)	<input type="checkbox"/>	<input type="checkbox"/>	<input type="checkbox"/>	23 SOUND LEVEL TEST (4.3.4.3)	<input type="checkbox"/>	<input type="checkbox"/>	<input type="checkbox"/>	24 <input type="checkbox"/> CLEANLINESS PRIOR TO FINAL ASSEMBLY (4.2.3.1)				25 <input type="checkbox"/> NOZZLE LOAD TEST (3.3.6)	<input type="checkbox"/>	<input type="checkbox"/>	<input type="checkbox"/>	26 <input type="checkbox"/> BRG HSG RESONANCE TEST (4.3.4.5)	<input type="checkbox"/>	<input type="checkbox"/>	<input type="checkbox"/>	27 <input type="checkbox"/> REMOVE/INSPECT HYDRODYNAMIC BEARINGS AFTER TEST (5.2.8.5)	<input type="checkbox"/>	<input type="checkbox"/>	<input type="checkbox"/>	28 <input type="checkbox"/> AUXILIARY EQUIPMENT TEST (4.3.4.4)	<input type="checkbox"/>	<input type="checkbox"/>	<input type="checkbox"/>	29 _____	<input type="checkbox"/>	<input type="checkbox"/>	<input type="checkbox"/>	30 _____	<input type="checkbox"/>	<input type="checkbox"/>	<input type="checkbox"/>	<p><b>GENERAL REMARKS</b></p> <p>REMARK 1: _____</p> <p>REMARK 2: _____</p> <p>REMARK 3: _____</p> <p>REMARK 4: _____</p> <p>REMARK 5: _____</p> <p>REMARK 6: _____</p>
TEST	NON-WIT	WIT	OBSERVE																																																		
19 HYDROSTATIC (4.3.2)	<input type="checkbox"/>	<input type="checkbox"/>	<input type="checkbox"/>																																																		
20 PERFORMANCE (4.3.3)	<input type="checkbox"/>	<input type="checkbox"/>	<input type="checkbox"/>																																																		
21 NPSH (4.3.4.1)	<input type="checkbox"/>	<input type="checkbox"/>	<input type="checkbox"/>																																																		
22 COMPLETE UNIT TEST (4.3.4.2)	<input type="checkbox"/>	<input type="checkbox"/>	<input type="checkbox"/>																																																		
23 SOUND LEVEL TEST (4.3.4.3)	<input type="checkbox"/>	<input type="checkbox"/>	<input type="checkbox"/>																																																		
24 <input type="checkbox"/> CLEANLINESS PRIOR TO FINAL ASSEMBLY (4.2.3.1)																																																					
25 <input type="checkbox"/> NOZZLE LOAD TEST (3.3.6)	<input type="checkbox"/>	<input type="checkbox"/>	<input type="checkbox"/>																																																		
26 <input type="checkbox"/> BRG HSG RESONANCE TEST (4.3.4.5)	<input type="checkbox"/>	<input type="checkbox"/>	<input type="checkbox"/>																																																		
27 <input type="checkbox"/> REMOVE/INSPECT HYDRODYNAMIC BEARINGS AFTER TEST (5.2.8.5)	<input type="checkbox"/>	<input type="checkbox"/>	<input type="checkbox"/>																																																		
28 <input type="checkbox"/> AUXILIARY EQUIPMENT TEST (4.3.4.4)	<input type="checkbox"/>	<input type="checkbox"/>	<input type="checkbox"/>																																																		
29 _____	<input type="checkbox"/>	<input type="checkbox"/>	<input type="checkbox"/>																																																		
30 _____	<input type="checkbox"/>	<input type="checkbox"/>	<input type="checkbox"/>																																																		

FIGURE 4E API 610 data sheets, page 5 of 5 (Courtesy American Petroleum Institute)

A life cycle cost equation, representing each of these cost components, is readily developed as follows:

$$LCC = C_{ic} + C_{in} + C_e + C_{aux} + C_m + C_l + C_d$$

The LCC is usually discounted to a present value, based on an assumed discount rate, inflation rate, and expected equipment life.

**TABLE 1** Utility cost comparison

Job No.:	1	2	3	4
Client:	Super Awesome			
Location:	Lake Charles, Louisiana			
Subject:	Job No. XXX, utility cost comparison for item low pressure boiler Feed S01/JA/JB/JC, water pumps 2 pumps normally operate—one motor / one turbine			
	Vendor "A"	Vendor "B"	Vendor "C"	
Motor drive:				
Normal BHP	100	110	90	
$\Delta$ BHP	10	20	0	
Penalty (\$750/hp*)	\$7500	\$15000	0	
Turbine drive:				
Normal BHP	100	110	0	
$\Delta$ BHP	10	20	0	
Norm. Stm. Rate (lb/BHP - hr)	15	14	16	
$\Delta$ STM. USED lb/hr	150	280	0	
Penalty (\$73.5/lb/hr**)	\$11,025	\$20,580	0	
Total Penalty (Motor + Turbine)	\$18,525	\$35,580	0	

\*Motor drive penalty basis:

$$\begin{aligned} \$/\text{hp} &= (\$0.039/\text{kWhr}) \times 8200 \text{ hr/yr} \times 3 \text{ yr} \times (0.746 \text{ kw/hr input}) / (0.95 \text{ hp/hp input}) \\ &\cong \$750/\text{hp} \text{ [for 3 yr]} \end{aligned}$$

\*\*Turbine drive penalty basis:

$$\begin{aligned} \$/(\text{lb/hr}) &= (\$0.003/\text{hr}) / (\text{lb/hr}) \times 8200 \text{ hr/yr} \times 3 \text{ yr} \\ &\cong 73.5/(\text{lb/hr}) \text{ [for 3 yr]} \end{aligned}$$

Assumptions

1. Utility evaluation is based on normal operating point.
2. Pay-out period is for three years (one year = 8200 operating hours)
3. Utility cost expressed as a penalty against equipment less efficient than the lowest utility consumer.
4. Estimated motor efficiency is 95%.

**Vendor Data Requirement (VDR) Form** For complicated equipment where many different documents are requested for submittal by the purchaser, a list of these documents is usually included in the requisition. This list should include a listing of each generic document, the number of copies required and the time after placement of purchase order that the document is required by the purchaser. Figures 5a and 5b are copies of typical VDR forms for an API-610 pump service.

It should be noted that requirements for drawings are significantly different for an end user maintenance group and an engineering contractor. Because documentation can add a significant amount to the purchase cost, care should be taken when specifying required drawings and drawing quantities.

**Inspection and Testing Checklist** For critical and special pump applications, the purchaser may require significant shop inspection and testing of the equipment above the vendor's standard procedures. This might include materials certification, NDE, welding inspections, rotor balancing, inspection reports, and mechanical/performance tests.

Figures 6a to 6c show typical Inspection and Testing documents that might be used for ASME, API-610, and other types of centrifugal pumping services. These documents allow the purchaser's representative to maintain a record of requirements for such items as the following:

TYPICAL CENTRIFUGAL PUMPS Vendor Drawing and Data Requirements							Page 1 Of 2	
pselvdr.xls		Job Number: XYZ Vendor:			Rev. No	0	1	
Drawings & Documents shall be submitted on agreed dates and as per specification.		Requestion No.: XYZ-1A/B-01			Date			
		P O Number:			Originator			
		Client: Chemical Company			Rev /Appr			
		Item / Tag No(s) : P-1A/B						
Drawings and Documents Description	Preliminary with fabricating proposed	Quantity to be Supplied After Award			SCHEDULE			
		Incoming Status			Lead Time for CF Drawings After Commitment			
		PR	CF	AB	Req'd Weeks	Prom'd Weeks	Agreed Date	
Completed Data Sheets for Pump Driver and Noise	✓							
A.1 Dimensioned Outline Drawings (Note1)								
a) Pump & Driver (w / Major & Minor Connections)								
b) Pump & Driver (w/o Minor Connections)	✓							
c) Auxiliary Equipment (Supplied but not mounted)								
d) Customer connection list								
e) Allowable Piping Forces and Moments								
f)								
A.2 Foundation Loading Diagrams	✓							
A.3 Schematic Wiring and/or Flow Diagrams								
a) Switch/Alarm Summary and Set Points								
b) Seal Systems Diagrams								
c) Lube Oil Diagrams								
d) Cooling Water Diagrams								
e) Bill of Material (BOM)								
f) Motor Wiring								
B.1 Detail Drawings								
a) Pump Cross Section	✓							
b) Coupling Cross Section								
c) Mechanical Seal Cross Section								
d) Gage Boards								
e)								
f)								
B.2 Erection/Assembly Drawings								
B.3 Predicted Performance Curves	✓							
C.1 Manufacturer's Data Reports								
a) Test Procedures								
b) Rotor Balance Reports								
c) Hydrotest Certificates								
d) Material Certificates								
e)								
Incoming Status				Drawings / Documents				
PR = Preliminary, CF = Certified, AB = As Built				P = Paper Print, R = Reproducible (Sepia)				

FIGURE 5A VDR form, page 1 of 2

- Witness test requirements
- Test procedures and approvals
- Preliminary test results before a witness travels to the vendor's shop
- Acceptability of test results
- Vibration limits



PUMP INSPECTION AND TESTING CHECKLIST

BY INSPECTOR'S	Number	0	1	2	3	4
	Date					
	Originator					
	Reviewed					
	Approved					

Job No.	XYZ	Page 1 of 3
Client	Chemical Company	
Location	Anywhere	
Unit	Utilities	
Item No.	P-1A/B	
Service	Boiler Feedwater Pump	
Requisition No.	XYZ-P1A/B-01	

Inspection & Testing Requirements						
DESCRIPTION OF EXAMINATION	Item Number					Legend:
						Comments
1						
2						
3						
4						
5						
6						
7						
8						
9						
10						
11						
12						
13						
14						
15						
16						
17						
18						
19						
20						
21						
22						
23						
24						
25						
26						
27						
28						
29						
30						
31						
32						
33						
34						
35						
36						
37						
38						
39						
40						
41						

FIGURE 6A Typical inspection and testing documents, page 1 of 3

equipment being purchased. One way to accomplish this is to include a noise data sheet that lists the allowable levels for the equipment provided. This data sheet should be designed to require the vendor to fill in the expected noise level for the equipment being offered. If the expected noise is greater than the specified maximum value, the vendor should be directed to provide special design options (that is, noise enclosure, WP II motor special noise ducting, and so on) to lower the expected noise level. See Figure 7 for a typical noise data sheet.

**Bidders List Preparation** The preparation of a bidders list for the required equipment on a project is of utmost importance. This list is comprised of suppliers that the client and purchaser agree are qualified to supply the needed equipment.

PUMP INSPECTION AND TESTING CHECKLIST

REVISIONS	Number	0	1	2	3	4
	Date					
	Originator					
	Reviewed					
	Approved					

Job No.	XYZ	Page 2 of 3
Client	Chemical Company	
Location	Anywhere	
Unit	Utilities	
Item No.	P-1A/B	
Service	Boiler Feedwater Pump	
Requisition No.	XYZ-P1A/B-01	

Inspection & Testing Requirements						
DESCRIPTION OF EXAMINATION	Item Number					Legend:
						Comments
						R = Report required, non-witnessed O = Observed W = Witnessed E = Examine X = Required NW = Not witnessed
7. Non-Destructive Examination						
a. Visual Weld Inspection						
b. MT or LPT Pressure Castings						
c. Radiography - Pump Nozzle						
8. Pressure Tests						
a. Hydrostatic Casing						
b. Hydrostatic Piping						
9. Material Test Certificate (MTR)						
a. Pressure Castings						
b. Impeller						
c. Piping						
10. Alloy Verification						
a. Casing						
b. Impeller						
11. Painting/Coatings						
12. Preparation For Shipment						
a. Release certificate						
<b>Testing</b>						Test results require approval by customer prior to shipping
13. Pump						
a. Performance						
b. NPSH						
c. Vibration measurement						
d. Bearing temperature measurement						
e. Dis-assembly inspection (bearings only)						
f. Sound level check						
g. Certified copies of test data						
14. Driver						

FIGURE 6B Typical inspection and testing documents, page 2 of 3

Qualification requirements may include a variety of categories such as the following:

- Vendor proven successful experiences supplying similar equipment
- Vendor ability to meet required delivery schedule
- Vendor ability to support field installation
- ISO 9001 certification standing
- Location of manufacture or material supply
- After sales service, spare parts supply, and so on



PUMP INSPECTION AND TESTING CHECKLIST

REVISIONS	Number	0	1	2	3	4
	Date					
	Originator					
	Reviewed					
	Approved					

Job No.	XYZ	Page 3 of 3
Client	Chemical Company	
Location	Anywhere	
Unit	Utilities	
Item No.	P-1A/B	
Service	Boiler Feedwater Pump	
Requisition No.	XYZ-P1A/B-01	

Inspection & Testing Requirements						
DESCRIPTION OF EXAMINATION	Item Numbers					Legend:
						Comments
83 a. Turbine						
84 Mechanical run						
85						
86						
87 b. Motor						
88 Routine test						
89 Complete test						
90						
91						
92 Notes:						
93						
94 1. Levels Of Inspection						
95 #1: Final inspection only and issue of inspection release						
96 certificate.						
97 #2: Pre-inspection meeting, random inspection, witness						
98 major tests, review documentation, and issue						
99 inspection release certificate.						
100 #3: Same as level #2 except regular inspection visits are						
101 more frequent. Witness/hold points will be as agreed						
102 at the pre-inspection meeting.						
103 #4: Resident company inspector continuously monitoring						
104 the work (in addition to the activities outlined in						
105 level # 2).						
106 2. Repair plan must be reviewed by purchaser prior						
107 to start of repairs.						
108 3. Test results shall be reviewed by purchaser prior						
109 to equipment shipping.						
110						
111						

FIGURE 6C Typical inspection and testing documents, page 3 of 3

If a proposed vendor is not known to the purchaser, a shop survey may be required to satisfy the purchaser of a potential supplier's ability. This type of survey will usually include an inspection and assessment of the manufacturer's shops, engineering and design facility, and quality assurance organization. The complexity of the required equipment and the project needs will determine the level of qualification required of the vendors. Remember that a vendor is required to provide not only the specified equipment, but also civil, piping, and electrical interface information required for project design. A vendor must possess the skills necessary to support all of these requirements.

The number of vendors that are to receive bid requests is usually between three and five. This number will provide for effective competition and will limit the quantity of quotes that require evaluation.

Pump alliance agreements, or the need to duplicate existing equipment, may reduce the list to a single bidder. In addition, unique design or vendor experience may dictate a sole source supplier.

**EQUIPMENT NOISE DATA SHEET**

DATE	NUMBER	0	1	2	3	4
	DATE					
	ORIGINATOR					
	REVIEWED					
	APPROVED					

psends

JOB NO.	PAGE 1 OF 1
CLIENT	Chemical Company
LOCATION	Anywhere
UNIT	Utilities
ITEM NO.	P-1A/B
SERVICE	Boiler Feedwater
REQUISITION NO.	XYZ-P-1A/B-01

1 DESIGN, MANUFACTURE, INSPECTION AND TESTING SHALL CONFORM TO THE SPECIFICATION: \_\_\_\_\_

2 INFORMATION TO BE COMPLETED :  BY PURCHASER  BY MANUFACTURER

**GENERAL**

4  Manufacturer: \_\_\_\_\_  Description of Equipment: \_\_\_\_\_

5 Location of Equipment:  Indoors  Outdoors  Under Roof  Partial Sides  Other: \_\_\_\_\_

6 Elevation of Equipment:  Grade  Mezzanine  Other: \_\_\_\_\_

**EQUIPMENT DESCRIPTION**

8 The Noise Data Provided Shall be a Composite of the Following Equipment: (Indicate all that Apply)

	Item No.	Type of Equipment (Pump, Motor, Valve, etc)	Description of Equipment (BkW, Flow Rate, etc.)	Mfr. Model No.
<input type="radio"/> Driven Equipment				
<input type="radio"/> Gear				
<input type="radio"/> Driver				
<input type="radio"/> Other:				
<input type="radio"/> Other:				

**SOUND PRESSURE LEVELS**

	A-Weighted	Sound Pressure Level (SPL) Decibels (dB) at 1 meter								
Octave Band Center Frequency (Hz) ▶		31.5	63	125	250	500	1000	2000	4000	8000
<input type="checkbox"/> Maximum Allowable										
<input type="checkbox"/> Std. Equip.: Driver	85 dBA									
<input type="checkbox"/> Std. Equip.: Driven Equipment	85 dBA									
<input type="checkbox"/> Std. Equip.:										
<input type="checkbox"/> Std. Equip.:										
<input type="checkbox"/> Std. Equip.: Lube System	NA									
<b>Noise Abated Equipment (Note 1)</b>										
<input type="checkbox"/>										
<input type="checkbox"/>										
<input type="checkbox"/>										

**Sound Pressure Level Remarks:**

31 Has the Noise Data Presented been Corrected to Predict the Expected Max. Noise Level at the Installation Site?  Yes

32  No ▶ Estimate the Correction to Predict the Expected Max. Noise Level at the Installation Site: Add/Subtract \_\_\_\_\_ dB

33 Source of Data:  Test Stand  Field  Shop Floor  Computation  No Data Available

34 Computational Basis:  Test Data  Field Data  Shop Data  Theory  By Subvendor  By Consultant

35 Data Condition:  Semi-Reverberant  Reverberant  Indoors  Outdoors  Free Field

36  Loaded  Unloaded  Averaged  Maximum

37  Includes Safety Factor of \_\_\_\_\_ dB

38 Additional Remarks:

39 **Note 1: Vendor to complete if needed to fulfill max. sound level requirement**

40 \_\_\_\_\_

41 \_\_\_\_\_

42 \_\_\_\_\_

43 Description of Noise Abatement: \_\_\_\_\_

44 \_\_\_\_\_

45 \_\_\_\_\_

46 Notes:

47 \_\_\_\_\_

48 \_\_\_\_\_

49 \_\_\_\_\_

50 \_\_\_\_\_

51 \_\_\_\_\_

FIGURE 7 Typical noise data sheet

**Bidding Time** The time required to prepare a bid will depend on the complexity of the equipment, the relative cost of buy-out items (such as exotic castings and turbine drivers), and the level of business activity in the market. It also depends on the number of pump services included in the requisition. The more sub-vendors the main equipment supplier must depend on, the longer the time needed for the vendor to provide an accurate quote.

As a guideline, the following timing may be used to set the bid due date.

#### Bid Preparation Time

Application	Weeks Required
Pre-engineered and conventional pumps—6 in (152 mm) discharge and smaller	2–3
Pumps with 8 in to 48 in (203 to 1219 mm) discharge	3–4
Larger pumps or multiple pump requisitions	4–6

Often a vendor may have several bids due at approximately the same time. For this and other reasons, vendors may ask that the bid due date be extended. Extensions can be granted if the project schedule allows for this extra time.

It is in the interest of the purchaser to be flexible on bidding time limits to avoid losing a potentially favorable bid. If a bid is extended, all bidders should be notified of the extension so the additional time can be used to improve all quotes.

In many cases, it may not be acceptable to extend a bid due date. If a project schedule is tight, timing may not allow for an extension. In the case of many public sector bids, bid openings are advertised long in advance and may not be extended for this reason.

**Pre-Bid Meeting** If the required equipment is for a complex or difficult service, or if project timing is such that the purchasing cycle must be minimized, a pre-bid meeting may be of benefit. This meeting should be held after the vendors have read the inquiry but before quote preparation has begun. During this meeting, the full range of requirements are reviewed and emphasized when necessary. Areas of compromise may be suggested. At this time, the vendor is free to ask questions and determine if alternatives to the specified equipment might be advantageous. If specification errors or oversights are noted during these meetings, all bidders must be quickly informed.

The chances of obtaining quotes that are usable without major upgrading are much more likely after a pre-bid meeting. This meeting might prevent a full re-bidding process that might be necessary if vendors misinterpret requirements or are not able to offer equipment in accordance with the inquiry.

**Evaluation of Bids** After the bid requisition has been prepared and sent to the approved pump vendors for quotation, it is time to start preparing bid review documents. Both commercial and technical evaluations will be necessary and can be accomplished on the same or separate documents.

**Review Strategies** Review strategies differ between projects and clients. Often, technical reviewers are not made aware of the quoted costs and are concerned only with technical specification compliance and scope of supply. In this case, the commercial evaluation is done by others. The final comparison of costs can be made after the various vendors quotes are conditioned to meet all technical requirements. If the cost is withheld from the technical reviewer, an important piece of evaluating information is missing, which increases the chance of missing key requirements. Based on a quick comparison of cost, it is easy for the document reviewer to establish the quoted general scope for each vendor. If large cost differences are noted between vendors, the reviewer must carefully determine what major differences in quoted scope likely exist.

The number of quotes that will be fully evaluated will depend partly on the number received. The goal is to ensure that the least expensive, technically acceptable bidder can be determined while also minimizing evaluation hours.

**Short Listing of Quotes** When bids are first received, a quick commercial and technical tabulation is often prepared that lists the main scope of supply, extent of specification compliance, major deviations, and the associated total cost. This is done to get a general

idea of the completeness of the quotes as well as to provide information to determine which of the quotes will be fully evaluated.

**Technical Bid Evaluation** Quotations must be evaluated against the specified requirements. Avoid a temptation to conditions bids so they are apples to apples. Comparing apples to oranges is acceptable providing that specified requirements are met. Professional ethics prohibit giving a vendor's better idea to competitors. A vendor should be encouraged to use ingenuity when preparing a quotation. One vendor's ingenuity should never be shopped around to the others.

After the decision is made on which bids to fully evaluate, the formal review and conditioning process can begin. A technical bid tabulation form is necessary to ensure that the equipment is provided in compliance with the requisition. This tabulation will list the important points of each vendor quote in table form. Each quote is then compared line by line.

Items that are usually contained in a technical bid tab include

- Equipment model number and size
- Compliance with process duty requirements (flow, head, *NPSHR*, and so on)
- Mechanical design limitations (pressure and temperature)
- Mechanical and hydraulic operating parameters (such as brake horsepower, head rise to shutoff, capacity rise to run out, percentage of best efficiency point)
- Mechanical design features (such as materials of construction, seal type, seal flush type, bearing and lubrication type)

When the technical bid evaluation form is being completed, the reviewer must highlight all items that do not meet requisition requirements or that are not clearly defined in the vendor's quote. In addition, features of the vendor's quotation should be highlighted to clearly indicate advantages, disadvantages, ambiguities, and non-compliances. A typical API-610 technical bid evaluation is shown in Figures 8a to 8c.

**Technical Quote Clarification Questions** When the initial review is complete, a list of clarification questions needs to be prepared and sent to each vendor being evaluated. Questions should be direct and concise to ensure that responses answer the questions asked. The vendors must be encouraged to provide cost adders, if necessary, to meet requisition requirements. It is usually appropriate to allow the vendors one week to reply.

When answers to the clarification questions are received, the bid tabulation must be updated to include any revisions in the vendors quotation. Care must be exercised in tracking revisions to the original quotation. If additional clarification is needed, there are various ways to go about it, depending on the situation. Some suggestions are detailed in the following sections.

**Telephone Inquiry** This method should be discouraged in all but the simplest cases. If used, notes of the telephone conversation must be recorded and filed for later reference. The applicable portion of the vendor quotation should be marked to reflect any changes, with proper reference made to where and why the changes were made. The vendor should confirm all answers in writing, even to verbal questions. Good documentation is necessary to clarify any future misunderstandings either before or after a purchase order is placed.

**E-mailed and Faxed Questions and Answers** It is preferable that questions be asked and answered by e-mail or fax. This will provide a positive information trail and can be as timely as a telephone conversation. Each vendor will require approximately one week to reply to this second round of questions.

**Vendor Clarification Meeting** Many factors will be used to determine if a vendor clarification meeting is necessary. Is the potential value of the order high enough to justify

Feed: Boiler Feedwater	Sp. Gr: 0.94
Flow Rate/Rated: 1500 / 1800 GPM	
Suct. Press. Max/Min: - / 5 PSIG	
Disch. Press: 1144 PSIG	
Diff. Pressure: 1139 PSI	
Diff. Head: 2880 FT	NPSHA 50 ft
Temp. - Normal/Max: 230 / - day C	Vapor Press: 24.8 psia
Drive Type: Motor	Visc: 0.7 cP

## Typical Centrifugal Pump Bid Tabulation

Job No.:	XYX	Page 8 of 3
Client:	Chemical Company	
Location:	Anywhere, World	
Item No.:	P-1A/B	
Service:	Boiler Feedwater Pump	
Requestor No.:	XYZ-1A/B-01	
Originator:	Joe Engineer	Date
Approver:	J. Senior Eng.	Rev No.

Pump Size and Model	Units	Specification	Pump Company A A-6 X 8 X 11 Six	Pump Company B B-6 X 8 X 11 Six	Pump Company C C-6 X 8 X 11 Six
Number of Stages:					
<b>PERFORMANCE:</b>					
Proposed Curve No.:		By Vendor	6 X 11 - A	6 X 11 - B	6 X 11 - C
RPM/Rotation:		By Vendor / CW	3670 / yes	3670 / yes	3560 / YES
Suction Specific Speed:		less than 11000	10680	7314	10900
Head - Rated/Maximum (C):	ft	By Vendor	2800 / 2408	2800 / 3180	2900 / 3420
% BEP @ Rated Flow & Rated Imp.:	%	By Vendor	100	95	100
% Max Head @ Rated Flow & Max Imp.:	%	By Vendor	99 (1)	90	94
% Head rise to Shut-off:	%	20	21	14 (acceptable)	22
Minimum Flow:	gpm	By Vendor	81	850	600
Efficiency, Rated:	%	By Vendor	81	79.4	80
BEIP, Rated/Maximum (EOC):	hp	By Vendor	1478 / 1531	1507 / 1700	1495 / 1533
NPSHR (@ C.L. of impeller):	ft	By Vendor	32.5	32.3	38
<b>CONSTRUCTION:</b>					
CASE - Horizontal/Vertical:		Horizontal	yes	yes	yes
Mount/Spin/Type (A):		CL / A / D / V	yes / yes / yes	yes / yes / yes	yes / yes / Yes
MAWP @ Rated Temp.:	psig	By Vendor	1500	2000	2500
MAWP, % of Max. Disch. Press.:	%		99	62	70
Hydro test Pressure:	psig	By Vendor	2250	3240	3000
Max. Discharge Pressure (B):	psig	By Vendor	1380	1300	1400
<b>IMPELLER:</b>					
Diameter, Rated/Max/Min:	inch	By Vendor	11.69 / 11.81 / 9.82	10.83 / 11.25 / 10	11.5 / 11.88 / 9.5
Rated Impeller Diameter, % of max.:	%	By Vendor	99 (1)	96	97
Suction - Single/Double:		By Vendor	single	double	single
Mount - Between Bearings/Overhung:		Between Bearings	yes	yes	yes
<b>SHAFT:</b>					
Diameter @ Sleeve:	inch		3.0	2.88	3.25
C.L. to C.L. of Bearings:	inch		68.69	ADVICE	69.8
L / D Ratio:			4000	ADVICE	3048
<b>NOZZLES</b>					
<b>PUMP:</b>					
Suction Size/Rating/Facing/Loc.:		900# / RF / Side	8" / yes / yes / yes	8" / yes / yes / yes	8" / yes / yes / yes
Discharge Size/Rating/Facing/Loc.:		900# / RF / Side	8" / yes / yes / yes	8" / yes / yes / yes	8" / yes / yes / yes
Vent/Drain:		Sch 180, SWF/langed	yes / yes / yes	yes / yes / yes	yes / yes / yes
<b>BEARINGS:</b>					
<b>PUMP:</b>					
Type - Radial/Thrust:		Sleeve / Til Pad	yes / yes	yes / yes	yes / yes
<b>ELECTRIC MOTOR</b>					
Type - Radial:		Sleeve	yes	yes	yes
<b>LUBRICATION SYSTEM</b>					
Measuring:		API 610 Force Feed	yes	yes	yes
Lube Pumps:		Separate Baseplate	yes	yes	yes
Material:		Rotary Type	yes	yes	yes
Filters:		Carbon Steel	yes	yes	yes
Material:		Dual, 10 micron	yes	yes	yes
Cooler:		Steel	yes	yes	yes
Material:		Single, TEMA C	yes	yes	yes
Reservoir Retention:		5 minutes	yes	yes	yes
Material:		Stainless steel	yes	yes	yes

FIGURE 8A Typical API 610 technical bid evaluation, page 1 of 3

# Typical Centrifugal Pump Bid Tabulation

Boiler Feedwater	Sp. Gr.	0.94
Flow Rate:	1500 / 1000 GPM	
Max Head:	- / 8 PSIG	
Pressure:	1144 PSIG	
Temperature:	1133 PSI	
Head:	2800 FT	NPSHA 50 ft
Motor:	250 / - deg C	Vapor Press: 24.8 psia
Motor:		Visc: 0.7 cP

Job No.	XYZ	Page 2 of 3
Client	Chemical Company	
Location	Anywhere, World	
Item No.	P-1A/B	
Service	Boiler Feedwater Pump	
Requestion No.	XYZ-1A/B-01	
Originator	Joe Engineer	Date
Approver	J. Senior Eng.	Rev No.

	Units	Specification	Pump Company A	Pump Company B	Pump Company C
Ring:		Butt welded	yes	yes	yes w/CS slip on flanges
Material:		SS downstream of filters	all stainless steel	all stainless steel	yes
PLING:					
Manufacturer/Model/Type:		DEF / Flexo / Disc	DEF / Flexo / Disc	DEF / Flexo / Disc	NA
Rated BHP @ Rated RPM	BHP	By Vendor	482 / 2282	ADVISE	512 / 3100
Coupling Guard		Non Sparking - Aluminum	yes	yes	yes
Material:		CDE / Flex / Disc	NA	NA	CDE / Flex / Disc
MECHANICAL SEAL:					
Manufacturer/Model:		NoLeak Seal Co. / Bestseal	Seal Co. / Bestseal	Seal Co. / Bestseal	Seal Co. / Bestseal
Seal Code:		BSTGN	BSTFN	BSTFM	BSTFN
Manufacturer's Seal Code:		SSOS	SSOS	SSOS	SSOS
Material Nameplate for Seal:		Required	yes	yes	yes
DIARY PIPING:					
Seal Piping Plan:		Plan 23 with TI	yes	yes	yes
Seal Piping Construction:		Stainless Steel Tubing	yes	yes	yes
Seal Shell Material:		Carbon steel	yes	yes	yes
Cooling Water Plan:		API Plan C	Not required	Not required	Not required
Cooling Piping Construction:		Galv steel, if supplied	NA	NA	NA
ALB:					
Material:		Carbon steel	12% Chrome	12% Chrome	12% Chrome
Seal:		12% chrome	yes	yes	yes
Seal/Impeller Wear Rings:		12% chrome	yes	yes	ni-resist
Material:		12% chrome	yes	yes	yes
Seal:		316 SS w/ chr oxide coating	ADVISE	ADVISE	ADVISE
Seal Housing:		By Vendor	CS & CI	Carbon steel	Carbon steel
TRIC MOTOR:					
Material:		C.I or Fab Steel	Fabricated steel	Fabricated steel	Fabricated steel
Impeller Box:		C.I or Fab Steel	Fabricated steel	Fabricated steel	Fabricated steel
Impeller Bar Rotor:		Required	yes	yes	yes
Air Filters:		Stainless steel	yes	yes	yes
Manufacturer:		By Vendor	Sparky Motor Co.	Sparky Motor Co	Motors Are Us
Rated Speed/PSF:	HP	By Vendor / 1800 / 1.15	1750 / yes / yes	1750 / yes / yes	1750 / yes / yes
Material:		WP II	yes	yes	yes
Material:		80 over 40 by Resistance	yes	yes	yes
Material:		Class F - VPI	yes	yes	yes
VENTATION:					
Material:		Not required	NA	NA	NA
Material:		Not required	NA	NA	NA
TRIC MOTORS:					
Material:		Not required	NA	NA	NA
Material:		Not required	NA	NA	NA
Material:		Required	yes	ADVISE Voltage	Advise voltage
Material:		Required	yes	yes	yes
Material:		Required	yes	yes	yes
Material:		Required	yes	yes	yes

FIGURE 8B Typical API 610 technical bid evaluation, page 2 of 3

11.27

for Feedwater	Sp. Gr:	0.94
/Rate: 1500 / 1800 GPM		
Max/Rate: -1.5 PSIG		
e: 1144 PSIG		
re: 1139 PSIG		
2600 FT	NPSHA	50 ft
m/Max: 250 / - deg C	Vapor Press:	24.8 psia
l: Motors	Visc:	0.7 cP

## Typical Centrifugal Pump Bid Tabulation

Job No.	XYZ	Page 3 of 3
Client	Chemical Company	
Location	Anywhere, World	
Item No.	P-1A/B	
Service	Boiler Feedwater Pump	
Request No.	XYZ-1A/B-01	
Originator	Joe Engineer	Date
Approver	J. Senior Eng	Rev No.

	Units	Specification	Pump Company A	Pump Company B	Pump Company C
Warning Arresters:		Required	yes	yes	yes
Warning Equipment:		Not required	NA	NA	NA
ANEQUS:					
Static Balance Rotor:		Req'd after each stage	yes	yes	yes
QC:		Manufacturer standard	yes	yes	yes
Paint:		Prepare for epoxy grout	yes	yes	yes
Parts (including spare rotor):		Required	yes	yes	yes
S:					
Performance - W/Non-wit:		Witnessed	yes	yes	yes
SH - W/Non-wit:		Witnessed, if required	Not required	Not required	Not required
Intro Test - W/Non-wit:		Witnessed	yes	yes	yes
Flow Level Required:		Reference only	NO	yes	NO
Test Report:		Casing and impellers	yes	yes	yes
Geographic Test:		Not applicable	--	--	--
Shipping Part or LPT:		Yes, Casing	yes	yes	To be announced
Acoustic Test:		Not applicable	--	--	--
Witness Test:		Not applicable	--	--	--
TRIC MOTORS:					
Alignment Test - W/Non-wit: NEMA MG-1		Non witness	yes	yes	yes
Complete Test - W/Non-wit: NEMA MG-1		Non witness	yes	yes	yes
Vibration Test:		Non witness	yes	yes	yes
Flow Level Check:		Sound Survey	yes	yes	yes
Flow balance report:		Required	yes	yes	yes
WEIGHTS & DIMENSIONS:					
Weight:		By Vendor			
Impeller:	pounds	By Vendor	6380	4720	10,000
Static Motor:	pounds	By Vendor	6450	6700	6700
Impeller:	pounds	By Vendor	4185	3555	included
Motor System:	pounds	By Vendor	2500	2500	2500
Space:	feet	By Vendor	78 X 210	advise	60 X 150
Acceptability:			yes	yes	yes

1. Unit: CL - Centrifugal, F - Foot, BR - Bracket, SPR - R - Radial, A - Axial, Type: D - Diffuser, SV - Single Volute, DV - Double Volute  
 2. x - discharge pressure based on rated impeller max. head (C), max. SG, max. suet pressure.  
 3. a - head is used to calculate (B) above. (B) plus max suet pressure shall not exceed MAMP of case @ rated temp.  
 4. SHR & NPSHA are referenced to impeller centerline (suet nozzle centerline for vertical in-line pumps).  
 5. OC = End of Curve  
 6. 7 has alternate impeller pattern to meet API 5% future head requirement.

FIGURE 8C Typical API 610 technical bid evaluation, page 3 of 3

the vendor's (or purchaser's) expenses associated with the meeting? Is the equipment sufficiently complex to warrant a face to face meeting to ensure full understanding between the vendor and purchaser? Is timing so critical that this method needs to be used to accelerate the clarification process?

As with any vendor communications, it is important to precisely minute all discussions during the meeting. The vendor and purchaser must both agree on the content and action items that have been noted. Agreements with commercial impact should be confirmed in writing by the vendor. Action items should be assigned to a specific individual with an agreed-upon closure date for each item.

**Commercial Evaluation During Technical Evaluation** Prior to completion of the technical evaluation, certain commercial items can be reviewed and negotiated with the vendors being evaluated. Terms and conditions of payment, guarantee/warranty, and proposed delivery schedule can usually be discussed in parallel with the technical conditioning of the bids.

**Technical Purchase Recommendation** When all issues of bid requisition non-compliance have been satisfactorily addressed, the engineer must recommend which vendor or vendors may be considered for purchase of the required pump. Usually, part of this recommendation is the completed and signed technical bid tabulation. The final bid tabulation may show that all (or none) of the vendors are in complete compliance with all requisition requirements. The bid tab should clearly show where all noncompliance occurs. On the tabulation, a statement of technical compliance or non-compliance for each quote that has been reviewed must be provided. Notes that clarify any ambiguous line item on the tabulation are highly recommended so reviewers will have as few questions as possible on the bid tabulation content.

The bid tab should be attached to a recommendation memo or letter that states the recommendations and provides adequate justification. If a vendor is not in full compliance with the bid requisition, this should be noted, along with other reasons that support the recommendation. All revisions made since the original submission of the quotations that are necessary for purchase must be addressed. This might take the form of a scope of supply listing for each recommended vendor that clearly defines what must be purchased to meet the requisition requirements.

If a vendor is clearly favored over others for technical reasons, this must be clearly stated. Because the purchase order is usually given to the lowest cost technically acceptable bidder, this type of preference must be compelling.

For vendors that have been listed as technically acceptable, recommended for purchase, a list that addresses vendor's exceptions to requisition requirements should be attached. These exceptions should be justified in the technical purchase recommendation.

**Commercial Purchase Recommendation** After the technical recommendation for purchase is complete, the commercial purchase recommendation may be completed. In addition to including the technical bid analysis, this recommendation should cover the following items (if applicable):

1. Listing of original vendor bid scope of supply and the associated cost(s)
2. Listing of revisions to the vendor's original quotes needed for requisition compliance with the associated cost(s)
3. Required spare parts cost
4. Shipping costs
5. Miscellaneous costs associated with documentation, inspection, and so on
6. Utility consumption cost evaluation
7. Agreed delivery schedule
8. Exceptions taken to commercial terms and conditions
9. Economic adjustments for different terms of payment



At this point, the purchase recommendation can be made, usually based on the lowest cost technically acceptable bidder.

**Final Purchase Decision and Purchase Order Issue** Now that the commercial purchase recommendation is complete, it is forwarded to the parties responsible for making the purchasing decision. After the selection is made, the engineer must decide if additional discussions with the vendor are needed prior to issue of the purchase order. For complex, costly equipment, and large orders, this extra discussion often takes place in a pre-award meeting.

During this meeting, the final agreed-upon equipment, technical, and commercial requirements are confirmed. A final review of the vendors technical exceptions to the requisition can also be completed at this point. As with previous meetings, recording all discussions and agreements is very important. Both parties should read and sign the meeting notes.

After final discussions are complete, the last step in purchasing the pump is the issue of the purchase order.

Because the paper trail for the purchasing cycle can be very complex, it is strongly suggested that the purchase order be a stand-alone document. It may or may not be sufficient to only reference previously transmitted narrative specifications. Many options are likely to have been discussed and agreed to during the process. All these agreements, even if properly documented during the process, should be incorporated into the purchase order. This includes revising data sheets as necessary and also incorporating agreed vendor exceptions to the inquiry. Don't make determining the requirements a treasure hunt for anyone involved later in the execution of the order.

Often it takes several days (or weeks) to incorporate all agreements to the various documents that are contained in the requisition. In order to permit the vendor to proceed in advance of the formal purchase order issue, a letter can be written by the purchaser that confirms the order and requests the vendor to begin work immediately.

**Summation of Pump Purchase Cycle** API-610 was used as the base document to specify the pump included for the hypothetical purchase in this chapter. It is considered a complex pumping service. Because of this, a large amount of documentation is necessary to describe the purchase requirements.

The other end of the spectrum might be the purchase of a standard drum pump directly from a supplier's catalog. In this case, a single page purchase order listing the model number and any available options would be adequate to ensure the correct selection for this simple service.

## **SELECTING AND PURCHASING PUMPS IN THE INFORMATION AGE** \_\_\_\_\_

Many firms are applying emerging information technologies during the process of selection and purchasing pumps to improve their competitiveness. Computer-based applications are often used to aid in generating pump proposals or to check part inventory status. Design departments use CAD/CAM systems to shorten the design cycle and run simulations using structural finite element methods. However, the use of computer technology alone does not guarantee a measurable economic benefit.

Organizational and process changes are usually necessary to achieve the benefits of computer automation. These process improvements often extend beyond a single firm with the formation of formal and informal alliances between pump users, owners, engineering contractors, architect-engineers, pump suppliers, and other equipment suppliers. These trends place a greater emphasis on the purchaser-supplier interface during the pump selection process. From the purchaser's perspective, the optimal choice of pumping equipment has significant cost implications over the service life of the equipment. From the manufacturer's perspective, configuring the preferred offering of pumping equipment is crucial in securing a competitive advantage during the purchase evaluation.

The information age is redefining virtually all aspects of conducting business including the way pumping systems are designed, evaluated, procured, manufactured, and main-

tained through their entire lifecycle. In this section, the process of selecting and purchasing pumps will be revisited in the context of the way critical information is communicated between pump purchaser and supplier. Then, four of the emerging information technologies that are contributing to improved quality and cycle time in the overall process will be described.

**Information Flow Between Purchaser and Supplier** Following the decision that pumping equipment is required, an Inquiry/Proposal process is undertaken involving the six major steps outlined in this chapter: (1) engineering the pumping system, (2) selecting the pump and driver type, (3) pump specification and data sheet preparation, (4) inquiry and quotation (proposal), (5) evaluate of bids and negotiation, and (6) purchase the selected pump and driver. The entire process is information intensive, consisting of both technical and commercial information. The first three steps of the process (steps 1–3) are technical in nature, involving the exchange of system design, pump specifications, and performance and construction details of the pump. The last three steps of the process (steps 4–6) transition toward the commercial elements of the purchasing decision such as equipment costs, life cycle cost evaluations, terms and conditions, and delivery lead-times. This flow of technical and commercial information is ascribed by the Inquiry—Quotation information exchange depicted in Figure 9.

This Inquiry—Quotation information exchange is not limited to only one purchaser-supplier interaction. With each new procurement opportunity, this information exchange effects every trading partner participating in the entire supply chain. Consider the simplified example (in Figure 10) of an Operating Company that gives three Engineering/Design contractors the opportunity to bid on an expansion of a chemical process plant. If each of these contractors issues three inquiries to pump manufacturers, nine inquiries are issued. Now, if each manufacturer issues three inquiries to their sub-suppliers, a total of 27 inquiries are pending for this single plant expansion. In the end, only one contractor, one equipment-supplier, and one sub-supplier actually receive orders to supply equipment for the project. Thus, only 3 inquiries out of 27 representing 11% of the total application and quotation effort represent “useful” work. These engineering costs are recovered only when equipment is actually purchased. The cost of the other 89% of effort by those participants in the Inquiry/Proposal process who did not receive a customer order are “wasted”

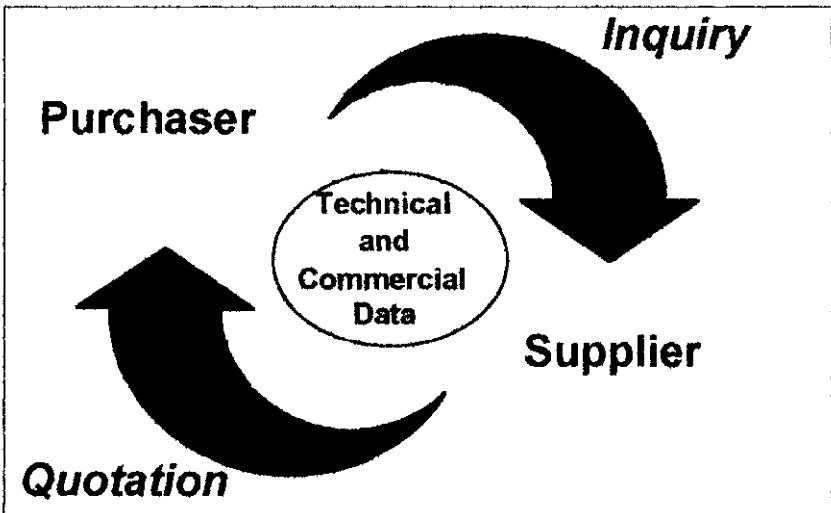


FIGURE 9 Purchaser supplier information exchange

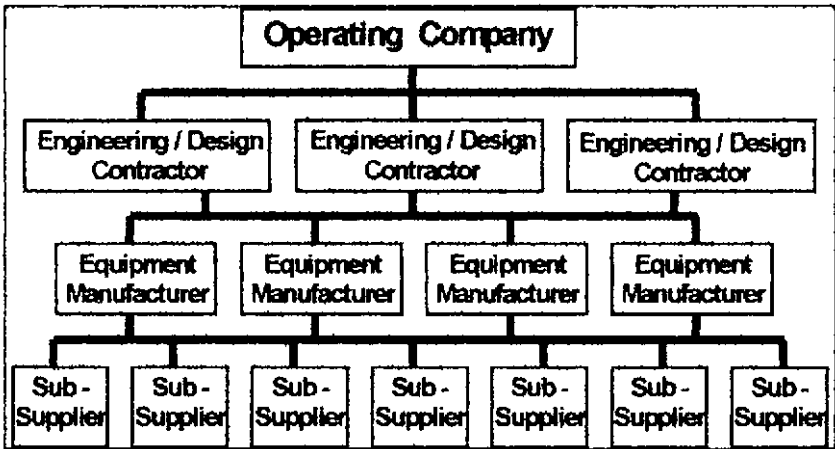


FIGURE 10 Multi-firm information flow

and absorbed as a sales and engineering overhead. This example actually understates the total number of inquiries issued indicating that the “wasted” effort is probably much greater than calculated.

To reduce costs, purchasers are seeking ways to reduce the engineering resources required to process this information without compromising the quality of the competitive evaluation. Similarly, suppliers are developing methods for responding to inquiries (or requests-for-quotation [RFQ]) with less resources and effort while striving to still provide high quality quotations to their customers. Simplifying the inquiry-quotation process is an attractive proposition for both purchaser and manufacturer.

**Strategies for Improving the Selection and Purchasing Process** Both purchaser and manufacturer in the Inquiry/Quotation Process are striving to enhance their competitiveness by reducing costs through process and information technology-oriented productivity improvements. *Intracompany* productivity gains have been the focus of many internal reengineering programs within a given firm. By their nature, these gains are limited to changes made within a single company and cannot effect improvements between multiple companies. However, the “ripple effect” on the total cost across multiple firms, described earlier, is a significant cost and represents a relatively unexplored opportunity for *Intercompany* productivity gains. Some of these cooperative strategies engaged by both purchaser and supplier include the following:

- Form alliances to streamline the Inquiry/Quotation process and flow of information across multiple firms
- Reduce the number of participants in the process by defining a preferred set of customers and suppliers
- Move the pump selection task earlier in the pumping system design process by providing purchasers’ access to computerized selection programs allowing the purchaser to optimize their process design
- Structure the flow of information between companies to reduce ambiguity and enhance common work processes

Existing and emerging information technologies offer a technology platform necessary to implement many of these strategies. The next section describes four of the information technologies that are particularly important in improving intercompany activities in the selection and purchasing process for pumping equipment.

**Applications of Emerging Information Technologies** Information Technologies are used throughout the design, manufacture, and maintenance of pumping equipment and systems. With respect to the specific activity of selecting and purchasing pumps, there are four important information technologies that are playing a more meaningful role, including (1) Pump System and Selection Programs, (2) Pump Configuration and Pricing Systems, (3) Electronic Data Exchange, and (4) the Internet.

**Pump System and Selection Programs** Designing the piping network and sizing the components for a pumping system are performed very early in the overall pump selection and purchasing process. The piping system design involves numerous components that introduce friction losses in the system. These must be calculated in order to estimate the behavior of the system resistance curve needed to properly size the pumps needed in the system. Changes in process conditions (pressure, temperature, fluid properties, tank elevation, and so on) or multiple/variable branch systems introduce additional operating conditions in the system design that must be predicted. This design process, when done manually, is tedious and time-consuming. However, handling design iterations and performing system optimization studies have become more practical with the use of computerized design and analysis programs.

Use of design and analysis programs became more prevalent in the mid-1980s with the advent of personal computers as powerful engineering workstations on the desktops of pumping equipment designers. These computers, with their easier to use software interfaces, encouraged the development of more robust and capable software applications that were more economical to deploy. Consequently, a substantial amount of effort went into the development of engineering programs dedicated to the sizing of piping systems, pumps, and other components.

Numerous Piping System Design/Analysis computer applications are now available to aid in the design or analysis of piping systems and their components. Most of these programs are based on simultaneous path solutions. The more complete programs easily model piping networks and are capable of calculating friction losses through pipes and fittings. They also contain large libraries of standard pumped liquids and their fluid properties such as density, viscosity, and vapor pressure as a function of temperature. These programs are more time-efficient and give more predictable results than former manual methods.

Some of these piping design/analysis programs also contain integrated pump selection programs. Performance curves from various pump manufacturers are digitally programmed and accessed by the program to establish preliminary pump performance and design specifications. These programs can be reasonably sophisticated, using specialized mathematical algorithms to predict pump performance under varying operating conditions of speed, temperature, *NPSHA*, pressure, viscosity, and so on. Some are even capable of adjusting performance based on alternative mechanical seal design, wearing ring design and clearance, bearing design, materials of construction, or other mechanical design features. There are over 30 different pump selection programs used in the industry today (Cotter, 1996). With few exceptions, these pump selection programs were specially developed by each pump manufacturer using proprietary selection and searching methods. These programs are available under a licensing agreement directly from the pump manufacturer and are usually the same programs used by their internal applications engineers. Some third-party programs are available incorporating product lines from multiple pump manufacturers. Versions of both manufacturers and third-party programs are readily available for download from the Internet.

Pump system and selection programs have improved the ability to evaluate large numbers of alternative design alternatives in a short period of time. Accurate performance calculations, even with variable pump speeds, fluid properties (viscosity, temperature, pressure), and mechanical configurations are readily predicted. Design and calculation errors have diminished and the overall quality of the process has greatly improved.

**Pump Configuration and Pricing** The primary tool that pump manufacturers traditionally use during the Inquiry/Quotation process is commonly known as the *Pricebook*. The *Pricebook* is a manual that contains extensive pump performance curves, materials

of construction, engineering data including dimensions and cross-sectional drawings, a plethora of guidelines on proper application of pumping equipment, and pricing information. Essentially, the Pricebook is an engineering design, specification, and pricing manual used by a trained pump applications engineer to convert a customer's inquiry into a customized quotation. These quotations include datasheets, performance curve, general arrangement drawings, and a price quotation including terms and conditions. In many cases, alternative selections, comments to the customer's specification, or other supplementary information are provided. The diverse array of information, expertise, and resources needed to generate a customized proposal has prompted the need to systematize the selection and configuration process using computer-aided tools.

Some manufacturers have responded by developing computerized product configurators. Product configurators aid the applications engineer in developing a pump quotation according to a prescribed product configuration model. These configurators are based on *design rules* and *configuration rules* that limit configuration choices. Examples of design rules are maximum casing pressure, maximum pump torque for a given shaft design, or the allowable temperature range for a given material. Using these design rules, a configurator could automatically upgrade a flange rating on a casing based on casing pressure or restrict the use of a gasket material as a function of temperature. Similarly, configuration rules ensure that a complete and permissible pump scope-of-supply is generated. For example, the mechanical seal type dictates the list of allowable seal flush piping options or the choice of pump and motor automatically defines coupling size required. These rules are coded into a knowledge base and serve to enforce product standardization and reduce configuration errors.

The pump selection program and the product configurator are the hub of the computer-aided tools used by the pump supplier to produce customized quotations. Supplementary programs are used to develop additional information such as pump performance curves, datasheets, general arrangement/outline drawings, and price make-ups. These programs have reduced the quotation cycle time while improving the quality and accuracy of the technical and commercial information required by the purchaser.

**Electronic Data Exchange** The communication of inquiry and quotation information is still predominately managed through paper-based methods in spite of the increasing use of computer-aided inquiry and quotation systems. The exchange of pump technical data has been traditionally handled using the pump datasheet. Both purchaser and manufacturer have developed their own datasheet formats. Consequently, each datasheet exchange requires a laborious translation and interpretation of information from one datasheet format to another.

With the implementation of computerized selection programs and bid-tab programs, this manual translation represents a lost opportunity to streamline the data communication process. In response, some firms have developed proprietary data exchange formats to leverage their own proprietary systems. Unfortunately, that approach has only shifted the burden to their trading partners who must develop special data translators to accommodate this wide variety of datasheet formats. It has been shown that the total number of translators needed for  $M$  data exchange formats follows the relationship,  $M \cdot (M - 1)$ . Therefore, 3 unique data formats require 6 translators, whereas 10 unique formats require 90 translators.

To halt this trend, a neutral data exchange specification was developed under the auspices of the American Petroleum Institute's Standard 610, *Centrifugal Pumps for Petroleum, Heavy Duty Chemical, and Gas Industry Services* (8th edition, August, 1995). This is used to exchange structured pump technical information reliably and efficiently between trading partners requiring each firm to develop only two translators (that is, input and output) to exchange pump data. The same neutral data exchange format has been adopted by *Process Industry Practices* (PIP). A number of purchasers and manufacturers are now using the data exchange file during the Inquiry/Quotation phase.

**The Internet** The use of the Internet has grown dramatically since the advent of the World Wide Web (WWW) in the mid-1990s. The rate of change on the Internet is witnessed in terms of days rather than years. Information or Web sites that exist on the Internet

today may be eliminated or replaced by tomorrow. As a consequence, any references about the use of the Internet for the selection and purchasing of pumping equipment will most likely be obsolete at the time the reader sees it. Nonetheless, it is prudent to anticipate the effect the Internet will have on this process in the pump industry.

Routine communications between purchaser and supplier are increasingly performed over the Internet using electronic mail (e-mail). E-mail is replacing both the paper mailings as well as the use of the fax because of its rapid delivery and ease with which messages are routed to multiple addressees. Other electronic documents such as spreadsheets, proposals, and drawings are readily communicated as file attachments in e-mail messages. Similarly, most purchasers and suppliers are developing, or re-developing a presence on the Internet with their own Web sites. These sites started as relatively simple sites displaying information about the company, its products, and company contact information. These sites improve the access of general information between trading partners, often replacing the need for mailing of brochures or other marketing information. More sophisticated sites are capable of conducting electronic commerce (e-commerce), described next.

The Internet is rapidly becoming the medium by which business-to-business (B-to-B) or electronic commerce will be conducted between trading partners in the future. The pump selection and purchasing processes described in this chapter will be substantially performed across the Internet in the future. Purchasers and suppliers will team up by either contacting each other through their own Web sites or by meeting through special "portals" or exchanges specifically established on the Internet for pumping equipment. These exchanges provide a natural place to host bulletin boards or discuss technical issues about pumping equipment. The pump system and selection processes described earlier will be Web-enabled, allowing users to perform these activities directly on the Internet. Similarly, the process of electronic data exchange will be performed across the Internet using structured data exchange methods that eliminate the manual re-entry of technical information between different systems. Standards created by either international standard bodies or a de facto standard created by a commercial entity will provide the necessary framework for this data exchange.

Finally, the actual business transactions involving inquiry, quotation, purchase order, and invoice will expand over the Internet. This process will evolve starting with commodity-type pumps and eventually will involve more sophisticated types of pumping equipment. Interactions during the order fulfillment cycle will be available such as order status information. Drawings, certifications, test data, and other technical information will be available as secure business transactions. The use of voice and video are also capable of replacing face-to-face meetings or equipment inspections that often involve detailed coordination and expensive travel.

## **SUMMARY**

---

The basic activities involved in the selection and purchasing of pumps as described at the beginning of this chapter are substantially the same now as in the past, and will be in the future. However, the processes and technologies employed in performing these activities are changing rapidly because of the Information age. The motivations surrounding these changes are driven by the desire for shorter cycle times, higher quality, and lower costs in the selection and purchasing process. These objectives are driven by the availability of new and emerging information technologies that offer a seamless and structured flow of information between the purchaser's and the supplier's sales, applications, engineering, and manufacturing functions. The availability of computer systems guarantees only that the infrastructure is in place to achieve the anticipated benefits. However, common work practices in both an intercompany and intracompany environment must be adopted and adapted to these new technologies. These process changes, not the availability of new information technologies, will govern the speed at which the pump industry changes in the future.

The emergence and use of new information technologies such as pumping system and selection systems, product configurators, electronic data exchange, and the Internet were

described. These technologies are in use today, but will be “re-invented” on the Internet in the future in ways that cannot be fully anticipated. However, the rapid changes brought on by the Information age must be recognized for what they are—a support process in the selection and purchase of pumping equipment. The information age will support, but not replace, the basic requirement to design, select, configure, and manufacture high quality and reliable pumps that support a substantial part of our modern life and industry today.

**INSTALLATION,  
OPERATION  
AND  
MAINTENANCE**

**Igor J. Karassik**

**C. C. Heald**



The information contained in this chapter is general and should be supplemented by the specific instructions prepared by the manufacturer of the pump in question.

## **INSTALLATION**

---

**INSTRUCTION BOOKS** Instruction books are intended to help keep the pumps in an efficient and reliable condition at all times. It is necessary, therefore, that instruction books be available to all personnel involved in this function.

**Preparation for Shipment** After a pump is assembled in the manufacturer's shop, it should be suitably prepared for the type of shipment the purchaser has specified. This can include blocking of the rotor, when necessary. If the rotor is blocked, this should be identified by weather-resistant tags. As shipped, the equipment should be suitable for at least six months of outdoor, uncovered storage from the time of shipment, with no disassembly required at the time of installation and operation except for possible inspection of bearings and seals. If storage for a longer time is required and specified, the manufacturer and purchaser should agree on the preparation and storage procedures and requirements prior to shipment.

The pump and driver should be prepared for shipment only after all testing and inspection processes have been completed and the equipment has been released for shipment by the purchaser. If packing was used for testing, it should be removed before shipment. Usually pumps are not disassembled after performance testing. The pump must be completely drained and dried, and all internal parts should be coated with a suitable rust preventative within four hours of testing. Alternatively, within four hours of testing, the pump and seal chamber should be drained to the extent practical, filled with a water-displacing inhibitor, and redrained before shipment.

Flanged openings should be provided with covers, usually metal, at least  $\frac{3}{16}$  in (5 mm) thick and sealed with an elastomeric gasket. Threaded openings should be closed with steel caps or plugs. Any openings that have been prepared for welding in the field should be provided with closures designed to protect against damage to the welding surface as well as the entrance of foreign materials into the equipment.

Exposed shafts and shaft couplings should be wrapped with waterproof cloth or paper and sealed with oil-proof adhesive tape. Bearing assemblies should be protected from moisture and dirt (dust). If vapor phase inhibitor crystals in bags are installed to absorb moisture, the location of the bags should be tagged so they will be removed before installation of the equipment in the field.

Usually a copy of the manufacturer's standard installation instructions is packed inside the equipment prior to shipment.

**Care of Equipment in the Field** The manufacturer should provide the purchaser with the instructions necessary to preserve the integrity of the original storage preparation when the equipment is received at the job site and prior to start-up. All equipment and materials should be stored free from direct ground contact and away from areas subject to collecting water. Indoor storage should be used whenever possible.

All carbon and low alloy steel surfaces should be protected from any contact with corrosive environments to prevent rust formation. All items with machined surfaces should be stored to facilitate periodic examination for damage or rust. Storage areas should be kept clean and free from such contaminants as concrete chipping, sanding, and painting.

Periodic rotation of equipment shafts should be performed in accordance with the equipment manufacturer's instructions for the specific equipment type and preservation methods used. When rotation is performed, determine first that all shipping blocks on rotating components have been removed and that there is adequate lubrication before rotation.

Certain preservatives and storage lubricants can affect safety and operating life of the equipment, especially if they react with the process fluid or operating lubricant. The

installer should ensure that all preservative and storage lubricants are suitable for the specific application. Preservatives should not be used on surfaces where prohibited by the process or application.

**Pump Location** Working space must be checked to assure adequate accessibility for maintenance. Axially split casing horizontal pumps require sufficient headroom to lift the upper half of the casing free of the rotor. The inner assembly of radially split multistage centrifugal pumps is removed axially (Subsection 2.2.1, Figure 23). Space must be provided so the assembly can be pulled out without canting it. For large pumps with heavy casings and rotors, a traveling crane or other facility for attaching a hoist should be provided over the pump location.

Pumps should be located as close as practicable to the source of liquid supply. Whenever possible, the pump centerline should be placed below the level of the liquid in the suction reservoir.

**Foundations** Foundations may consist of any structure heavy enough to afford permanent rigid support to the full area of the baseplate and to absorb any normal strains or shocks. Reinforced concrete foundations built up from solid ground are the most satisfactory. Although most pumping units are mounted on baseplates, very large equipment may be mounted directly on the foundations by using soleplates under the pump and driver feet. Misalignment is corrected with shims.

The space required by the pumping unit and the location of the foundation bolts are determined from the drawings supplied by the manufacturer. Each foundation bolt (Figure 1) should be surrounded by a pipe sleeve three or four diameters larger than the bolt. After the concrete foundations are poured, the pipe is held solidly in place but the bolt may be moved to conform to the corresponding hole in the baseplate.

When a unit is mounted on steelwork or some other structure, it should be placed directly over or as near as possible to the main members, beams, or walls and should be supported so the baseplate cannot be distorted or the alignment disturbed by any yielding or springing of the structure or of the baseplate.

**Mounting of Vertical Wet-Pit Pumps** A curb ring or soleplate must be used as a bearing surface for the support flange of a vertical wet-pit pump. The mounting face must be machined because the curb ring or soleplate will be used in aligning the pump.

If the discharge pipe is located below the support flange of the pump (belowground discharge), the curb ring or soleplate must be large enough to pass the discharge elbow during assembly. A rectangular ring should be used (Figure 2). If the discharge pipe is located above the support flange (aboveground discharge), a round curb ring or soleplate should be provided with clearance on its inner diameter to pass all sections of the pump below the support flange (Figure 3). A typical method of arranging a grouted soleplate for vertical pumps is shown in Figure 4.

If the discharge is belowground and an expansion joint is used, it is necessary to determine the moment that may be imposed on the structure. The pump casing should be attached securely to some rigid structural members with tie rods. If vertical wet-pit pumps are very long, some steadying device is required irrespective of the location of the discharge or of the type of pipe connection. Tie rods can be used to connect the unit to a wall, or a small clearance around a flange can be used to prevent excessive displacement of the pump in the horizontal plane.

**Alignment** When a complete unit is assembled at the factory, the baseplate is placed on a flat, even surface; the pump and driver are mounted on the baseplate; and the coupling halves are accurately aligned, using shims under the driver mounting surfaces where necessary. The pump is usually doweled to the baseplate at the factory, but the driver is left to be doweled after installation at the site.

The unit should be supported over the foundation by short strips of steel plate or shim stock close to the foundation bolts, allowing a space of  $\frac{1}{4}$  to 2 in (2 to 5 cm) between the bottom of the baseplate and the top of the foundation for grouting. The shim stock should extend fully across the supporting edge of the baseplate. The coupling bolts should be

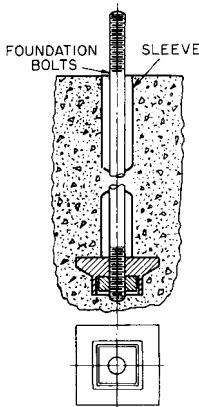


FIGURE 1 Foundation bolt

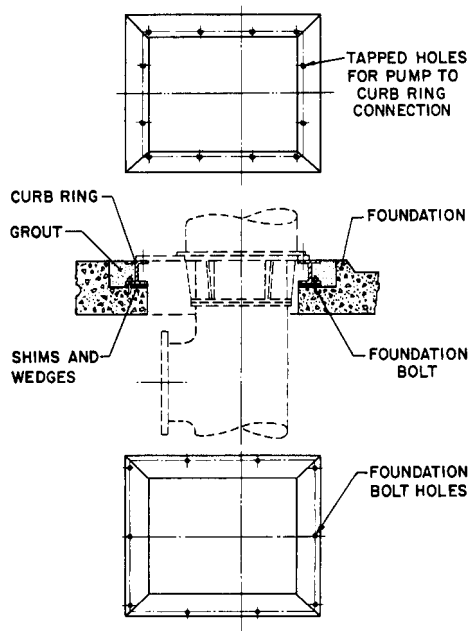


FIGURE 2 Rectangular curb ring for belowground discharge vertical pump

removed before the unit is leveled and the coupling halves are aligned. Where possible, it is preferable to place the level on some exposed part of the pump shaft, sleeve, or planed surface of the pump casing. The steel supporting strips or shim stock under the baseplate should be adjusted until the pump shaft is level, the suction and discharge flanges are vertical or horizontal as required, and the pump is at the specified height and location. When the baseplate has been leveled, the nuts on the foundation bolts should be made handtight.

During this leveling operation, accurate alignment of the unbolted coupling halves must be maintained. A straightedge should be placed across the top and sides of the coupling, and at the same time the faces of the coupling halves should be checked with a tapered thickness gage or with feeler gages (Figure 5) to see that they are parallel. For all alignment checks, including parallelism of coupling faces, both shafts should be pressed hard over to one side when taking readings.

When the peripheries of the coupling halves are true circles of equal diameter and the faces are flat and perpendicular to the shaft axes, exact alignment exists when the distance between the faces is the same at all points and when a straightedge lies squarely across the rims at any point. If the faces are not parallel, the thickness gage or feelers will show variation at different points. If one coupling is higher than the other, the amount may be determined by the straightedge and feeler gages.

Sometimes coupling halves are not true circles or are not of identical diameter because of manufacturing tolerances. To check the trueness of either coupling half, rotate it while holding the other coupling half stationary and check the alignment at each quarter turn of the half being rotated. Then the half previously held stationary should be revolved and the alignment checked. A variation within manufacturing limits may be found in either of the half-couplings, and proper allowance for this must be made when aligning the unit.

A more exact method for checking alignment that is recommended requires the use of a dial indicator. With the indicator bolted to the pump half of the coupling, both radial and

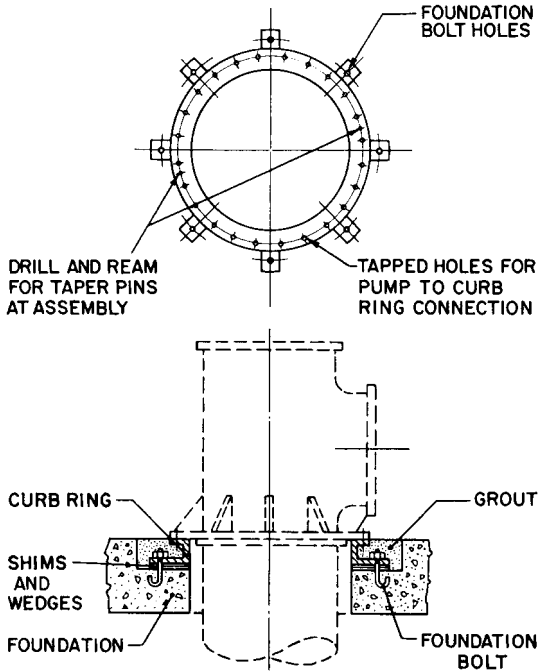


FIGURE 3 Round curb ring for aboveground discharge vertical pump

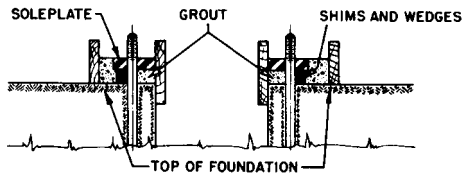


FIGURE 4 Grouting form for vertical pump soleplate (ANSI B-58.1 [AWWAE 101-61])

axial alignment can be checked, as illustrated in Figure 6. This method is called face-and-rim alignment. With the button resting on the periphery of the other coupling half, the dial should be set at zero and a mark chalked on the coupling half at the point where the button rests. For any check (top, bottom, or sides), both shafts should be rotated the same amount, that is, all readings on the dial should be made with the button on the chalk mark. The dial readings will indicate whether the driver must be raised, lowered, or moved to either side. After any movement, it is necessary to check that the coupling faces remain parallel to one another.

For example, if the dial reading at the starting point is set to zero and the diametrically opposite reading at the bottom or sides shows  $\pm 0.020$  in ( $\pm 0.508$  mm), the driver must be raised or lowered by shimming or moved to one side or the other by half of this reading. The same procedure is used to align gear couplings, but the coupling covers must first be moved back out of the way and all measurements should be made on the coupling hubs.

When a spacer-type coupling connects the pump to its driver, a dial indicator should be used to check the alignment (Figure 7). The spacer between the coupling halves should be removed to expose the coupling hubs. The coupling nut on the end of the shaft may be used

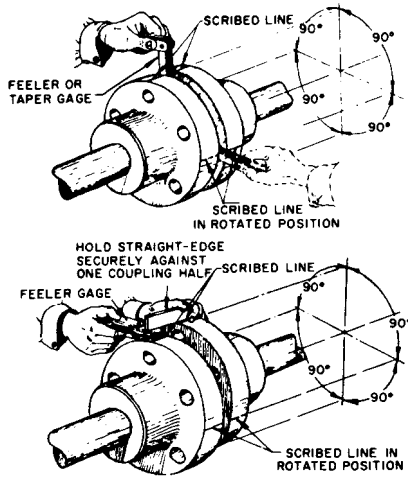


FIGURE 5 Coupling alignment using feeler gages

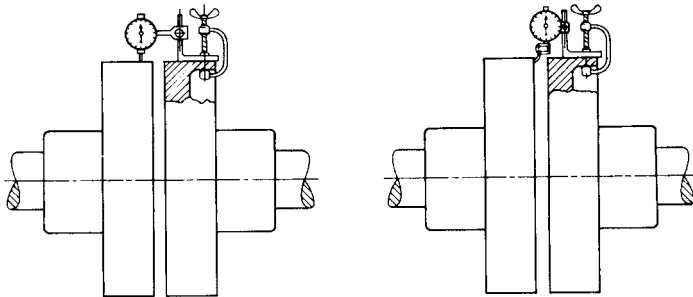


FIGURE 6 Use of dial indicator for face-and-rim alignment of standard coupling

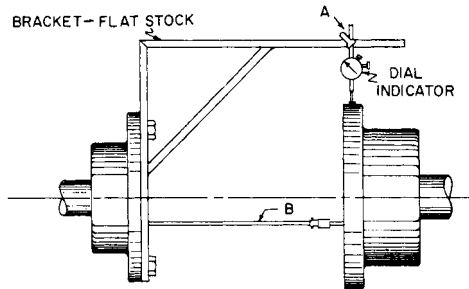


FIGURE 7 Use of dial indicator for face-and-rim alignment of spacer-type coupling

to clamp a suitable extension arm or bracket long enough to extend across the space between the coupling hubs. The dial indicator is mounted on this arm, and alignment is checked for both concentricity of the hub diameters and parallelism of the hub faces.

Changing the arm from one hub to the other provides an additional check. The dial extension bracket must be checked for sag, and readings must be corrected accordingly.

The clearance between the faces of the coupling hubs and the ends of the shafts should be such that they cannot touch, rub, or exert a pull on either pump or driver. The amount of this clearance may vary with the size and type of coupling used. Sufficient clearance will allow unhampered endwise movement of the shaft of the driving element to the limit of its bearing clearance. On motor-driven units, the magnetic center of the motor will determine the running position of the motor half-coupling. This position should be checked by running the motor uncoupled. This will also permit checking the direction of rotation of the motor. If current is not available at the time of installation, move the motor shaft in both directions as far as the bearings will permit and adjust the shaft centrally between these limits. The unit should then be assembled with the correct gap between the coupling halves.

Large horizontal sleeve-bearing motors are not generally equipped with thrust bearings. The motor rotor is permitted to float, and as it will seek its magnetic center, an axial force of rather small magnitude can cause it to move off this center. Sometimes it will move enough to cause the shaft collar to contact and possibly damage the bearing. To avoid this, a limited-end-float coupling is used between the pump and the motor on all large units to restrict the motor rotor (Subsection 6.3.1). The setting of axial clearances for such units should be given by the manufacturer in the instruction books and elevation drawings.

When the pump handles a liquid at other than ambient temperature or when it is driven by a steam turbine, the expansion of the pump or turbine at operating temperature will alter the vertical alignment. Alignment should be made at ambient temperature with suitable allowances for the changes in pump and driver centerlines after expansion. The final alignment must be made with the pump and driver at their normal temperatures and adjusted as required before the pump is placed into permanent service.

For large installations, particularly with steam-turbine-driven pumps, more sophisticated alignment methods are sometimes employed, using proximity probes and optical instruments. Such procedures permit checking the effect of temperature changes and machine strains caused by piping stresses while the unit is in operation. When such procedures are recommended, they are included with the manufacturer's instructions.

When the unit has been accurately leveled and aligned, the hold-down bolts should be gently and evenly tightened before grouting. The alignment must be rechecked after the suction and discharge piping has been bolted to the pump to test the effect of piping strains. This can be done by loosening the bolts and reading the movement of the pump, if any, with dial indicators.

The pump and driver alignment should be occasionally rechecked because misalignment may develop from piping strains after a unit has been operating for some time. This is especially true when the pump handles hot liquids because there may be a growth or change in the shape of the piping. Pipe flanges at the pump should be disconnected after a period of operation to check the effect of the expansion of the piping, and adjustments should be made to compensate for this.

For a further discussion of hot and cold alignment, face-and-rim versus reverse dial methods measurement of dial bracket sag, and graphical alignment plotting procedure, refer to Subsection 2.3.3.

**Grouting** Ordinarily, the baseplate is grouted before the piping connections are made and before the alignment of the coupling halves is finally rechecked. The purpose of grouting is to prevent lateral shifting of the baseplate, to increase the mass to reduce vibration, and to fill in irregularities in the foundation. Generally, it is recommended that all permanently installed pumping equipment be supported by a reinforced concrete foundation. Some pumps that require an elevated installation may be supported on structural steel structures, but care must be taken to ensure that such structures are of adequate stiffness and strength.

Foundation dimensions must consider the size and arrangement of the pump and driver, the piping arrangement and anticipated piping loads, anchor bolt placement, and minimum dimensions required for servicing the equipment. Vertically suspended canned

pump foundations should be designed so the pump can be directly attached to a mounting plate and is removable without disturbing the grout.

Foundation materials must be properly resistant to chemicals and oils. If the environment is aggressive, protective coatings or covers should be considered to protect the foundation and reinforcing steel. Two types of grout are commonly used: epoxy and cement-based. Epoxy grout, although usually more expensive, has significant advantages in higher bond strength and nonporous finished surface characteristics that generally make it the material of choice for most pump installations.

When the foundation has been prepared, the grout material has been selected, and the baseplate has been properly positioned on the foundation, a preliminary coupling alignment is made to ensure that final alignment is possible after the baseplate is finally grouted. After this alignment check is successfully accomplished, the grout is added through the holes in the baseplate. To retain the grout in place, a leak-tight form is built around the outside of the baseplate. Grout is added until the entire space under the baseplate is filled to the top of the underside (Figure 8). The grout holes and vent holes in the baseplate allow air to escape as the grout fills the cavity. A stiff wire may be used through the grout holes to work the grout and release any air pockets. It is usually best to start at one end and force the air out as the grout proceeds toward the other end of the baseplate. Leveling shims and wedges used to level the baseplate should be left in place after grouting.

When the grout has properly cured, voids have been filled and forms have been removed, the exposed surfaces of the grout and foundation can be properly finished. The foundation anchor/hold-down bolts should be finally torqued to the proper values and the coupling halves can be rechecked for alignment.

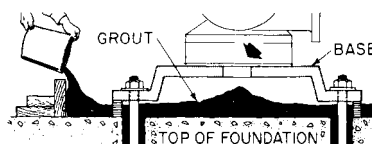
The pump and driver alignment must be rechecked thoroughly after the grout has hardened permanently, and at reasonable intervals thereafter.

**Doweling of Pump and Driver** When the pump handles hot liquids, doweling of both the pump and its driver should be delayed until the unit has been operated. A final recheck of alignment with the coupling bolts removed and with the pump and driver at operating temperature is advisable before doweling.

Large pumps handling hot liquids are usually doweled near the coupling end, allowing the pump to expand from that end out. Sometimes the other end is provided with a key and a keyway in the casing foot and the baseplate.

## PIPING

**Suction Piping** The suction piping should be as direct and short as possible. If a long suction line is required, the pipe size should be increased to reduce frictional losses. (The exception to this recommendation is in the case of boiler-feed pumps, where difficulties may arise during transient conditions of load change if the suction piping volume is excessive. This is a special and complex subject, and the manufacturer should be consulted.) Where the pump must lift the liquid from a lower level, the suction piping should be laid out with a continual rise toward the pump, avoiding high spots in the line to prevent the formation of air pockets. Where a static suction head will exist, the pump suction piping should slope continuously downward to the pump.



**FIGURE 8** Application of grouting. Grout is added until the entire space under the base is filled. Holes in the base (arrow) allow air to escape and permit working of the grout to release air pockets.

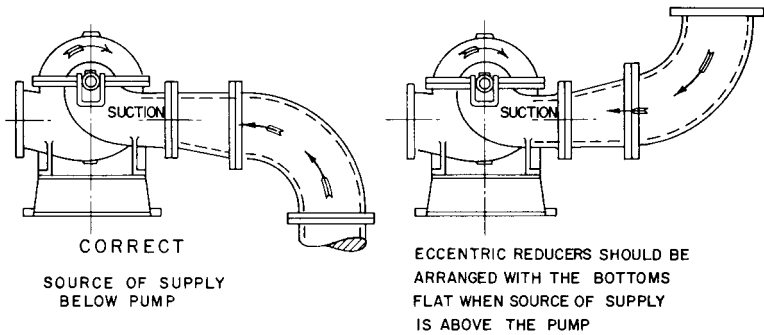


FIGURE 9 Recommended installation of reducers at pump suction

Generally, the suction line is larger than the pump suction nozzle and eccentric reducers should be used. If the source of supply is above the pump centerline, the reducer should be installed straight side up. If the source of supply is above the pump, the straight side of the reducer should be at the bottom (Figure 9). Installing eccentric reducers with a change in diameters greater than 4 in (10 cm) could disturb the suction flow. If such a change is necessary, it is advisable to use properly vented concentric reducers.

Elbows and other fittings next to the pump suction should be carefully arranged, or the flow into the pump impeller will be disturbed. Long-radius elbows are preferred for suction lines because they create less friction and provide a more uniform flow distribution than standard elbows.

It is extremely important to avoid the formation of vortices at the suction of both wet-pit and dry-pit pump installations. For a discussion of this and other suction conditions recommendations, see Sections 10.1 and 10.2.

**Discharge Piping** Generally both a check valve and a gate valve are installed in the discharge line. The check valve is placed between the pump and the gate valve and protects the pump from reverse flow in the event of unexpected driver failure or from reverse flow from another operating pump. The gate valve is used when priming the pump or when shutting it down for inspection and repairs. Manually operated valves that are difficult to reach should be fitted with a sprocket rim wheel and chain. In many cases, discharge gate valves are motorized and can be operated by remote control.

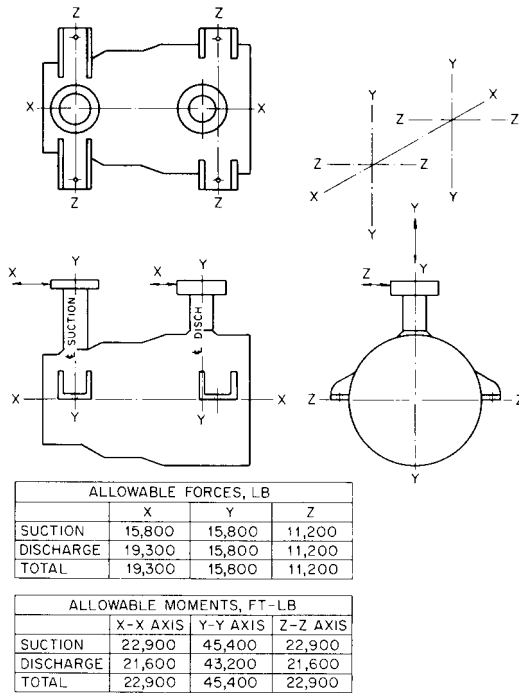
**Piping Strains** Cast iron pumps are never provided with raised face flanges. If steel suction or discharge piping is used, the pipe flanges should be of the flat-face and not the raised-face type. Full-face gaskets must be used with cast iron pumps.

Piping should not impose excessive forces and moments on the pump to which it is connected because these might spring the pump or pull it out of position. Piping flanges must be brought squarely together before the bolts are tightened. The suction and discharge piping and all associated valves, strainers, and so on should be supported and anchored near to but independent of the pump, so no strain will be transmitted to the pump casing.

There are four factors to be considered in determining the effect of nozzle loads: material stress in pump nozzles resulting from forces and bending moments, distortion of internal moving parts affecting critical clearances, stresses in pump hold-down bolts, and distortion in pump supports and baseplates resulting in driver coupling misalignment. API Standard 610 (Centrifugal Pumps for Refinery, Heavy Duty Chemical, and Gas Industry Services) provides guidelines for limiting the magnitude of nozzle loads and moments on pumps with suction nozzles 16 in (41 cm) and smaller and with casings constructed of steel or alloy steel.

With large pumps or when major temperature changes are expected, the pump manufacturer generally indicates to the user the maximum moments and forces that can be





**FIGURE 10** Diagram of typical permissible pipe stresses and moments for a radially split double-casing multistage pump with top suction and discharge ( $1 \text{ N} = 0.225 \text{ lb}$ ;  $1 \text{ N} \cdot \text{m} = 0.737 \text{ ft} \cdot \text{lb}$ ).

imposed on the pump by the piping. A typical diagram is illustrated in Figure 10 for a radially split double-casing multistage pump with top suction and discharge.

**Expansion Joints** Expansion joints are sometimes used in the discharge and suction piping to avoid transmitting any piping strains caused by misalignment or by expansion when hot liquids are handled. On occasion, expansion joints are formed by looping the pipe. More often, they are of the slip-joint or corrugated-diaphragm type. However, they transmit to the pump a force equal to the area of the expansion joint times the pressure in the pipe. These forces can be of very significant magnitude, and it is impractical to design the pump casings, baseplates, and so on to withstand them. Consequently, when expansion joints are used, a suitable pipe anchor must be installed between them and the pump proper. Alternately, tie rods can be used to prevent the forces from being transmitted to the pump.

**Suction Strainers** Except for certain special designs, pumps are not intended to handle liquid containing foreign matter. If the particles are sufficiently large, such foreign matter can clog the pump, reduce its capacity, or even render it altogether incapable of pumping. Small particles of foreign matter may cause damage by lodging between close running clearances. Therefore, proper suction strainers may be required in the suction lines of pumps not specially designed to handle foreign matter.

In such an installation, the piping must first be thoroughly cleaned and flushed. The recommended practice is to flush all piping to waste before connecting it to the pump. Then a temporary strainer of appropriate size should be installed in the suction line as close to the pump as possible. This temporary strainer may have a finer mesh than the

permanent strainer installed after the piping has been thoroughly cleaned of all possible mill scale or other foreign matter. The size of the mesh is generally recommended by the pump manufacturer. For further details on strainers, see Sections 8.1 and 10.1.

**Venting and Draining** Vent valves are generally installed at one or more high points of the pump casing waterways to provide a means of escape for air or vapor trapped in the casing. These valves are used during the priming of the pump or during operation if the pump should become air- or vapor-bound. In most cases, these valves need not be piped up away from the pump because their use is infrequent, and the vented air or vapors can be allowed to escape into the surrounding atmosphere. On the other hand, vents from pumps handling flammable, toxic, or corrosive fluids must be connected in such a way that they endanger neither the operating personnel nor the installation. The suction vents of pumps taking liquids from closed vessels under vacuum must be piped to the source of the pump suction above the liquid level.

All drain and drip connections should be piped to a point where the leakage can be disposed of or collected for reuse if worth reclaiming.

**Warm-Up Piping** When it is necessary for a pump to come up to operating temperature before it is started up or to keep it ready to start at rated temperature, provision should be made for a warm-up flow to pass through the pump. There are a number of arrangements used to accomplish this. If the pump operates under positive pressure on the suction, the pumped liquid can be permitted to drain out through the pump casing drain connection to some point at a pressure lower than the suction pressure (Figure 11). Alternately, some liquid can be made to flow back from the discharge header through a jumper line around the check valve into the pump and out into the suction header (Figure 12). An orifice is provided in this jumper line to regulate the amount of warm-up flow. Care must be exercised in such an installation to maintain the suction valve open (unless the warm-up line valve is closed, as when the pump is to be dismantled) lest the entire pump, suction valve, and suction piping be subjected to full discharge pressure.

The manufacturer's recommendations should be sought in all cases as to the best means of providing an adequate warm-up procedure. Care must be taken to ensure that the pump is warmed uniformly. Stratification of the warm-up flow, or inadequate warm-up flow volume, can result in casing distortion or rotor bowing, or both.<sup>4</sup>

**RELIEF VALVES** Positive displacement pumps, such as rotary and reciprocating pumps, can develop discharge pressures much in excess of their maximum design pressures. To protect these pumps against excessive pressures when the discharge is throttled or shut off, a pressure relief valve might be used. Some pumps are provided with internal integral relief valves, but unless operation against a closed discharge is both infrequent and of very

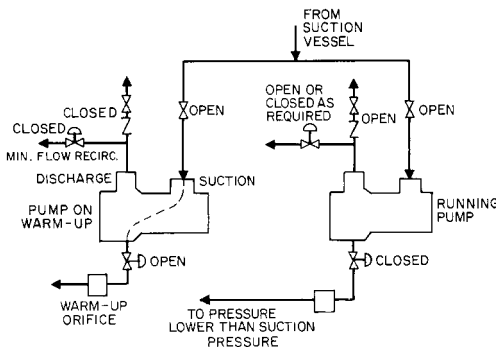


FIGURE 11 Arrangement for warm-up through pump casing drain connection

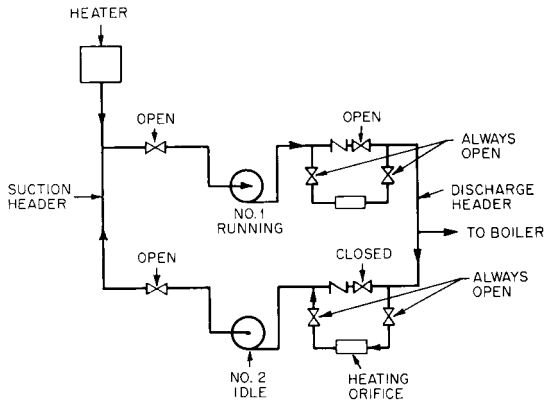


FIGURE 12 Arrangement for warm-up through jumper line around discharge check valve

short duration, a relief valve with an external return connection must be used and the liquid from the relief valve must be piped back to the source of supply.

**Surge Chambers** Generally, centrifugal pumps do not require surge chambers in their suction or discharge piping. Reciprocating pumps may have a suction and discharge piping layout that does not require compensation for variations in the flow velocity in the piping system. In many cases, however, reciprocating pump installations require surge chambers when the suction or discharge lines are of considerable length, when there is an appreciable static head on the discharge, when the liquid pumped is hot, or when it is desirable to smooth out variations in the discharge flow. The type, size, and arrangement of the surge chamber should be chosen on the basis of the manufacturer's recommendations. For more details, see Section 3.4.

**Instrumentation** There are a number of instruments that are essential to maintaining a close check on the performance and condition of a pump. A compound pressure gage should be connected to the suction of the pump, and a pressure gage should be connected to its discharge at the pressure taps that may be provided in the suction and discharge flanges. The gages should be mounted in a convenient location so they can be easily observed.

In addition, it is advisable to provide a flow-metering device. Depending upon the importance of the installation, indicating meters may be supplemented by recording attachments.

Whenever pumps incorporate various leakoff arrangements, such as a balancing device or pressure-reducing labyrinths, a check should be maintained on the quantity of these leakoffs by measuring orifices and differential gages installed in the leakoff lines.

Pumps operating in important or complex services or operating completely unattended by remote control may have additional instrumentation, such as speed indicators, vibration monitors, and bearing or casing temperature indicators. For more detail, see Subsections 2.3.2, 2.3.3, and Section 3.4.

## OPERATION

Pumps are generally selected for a given capacity and total head when operating at rated speed. These characteristics are referred to as "rated conditions of service" and, with few exceptions, represent those conditions at or near which the pump will operate the greatest part of the time. Positive displacement pumps cannot operate at any greater flows than

rated except by increasing their speed, nor can they operate at lower flows except by reducing their operating speed or bypassing some of the flow back to the source of supply. (See Section 3.5.)

On the other hand, centrifugal pumps can operate over a wide range of capacities, from near zero flow to well beyond the rated capacity. Because a centrifugal pump will always operate at the intersection of its head-capacity and system-head curves, the pump operating capacity may be altered either by throttling the pump discharge (hence altering the system-head curve) or by varying the pump speed (changing the pump head-capacity curve). This makes the centrifugal pump very flexible in a wide range of services and applications that require the pump to operate at capacities and heads differing considerably from the rated conditions. There are, however, some limitations imposed upon such operation by hydraulic, mechanical, or thermodynamic considerations (Subsection 2.3.1).

**Operation of Centrifugal Pumps at Reduced Flows** There are certain minimum operating flows that must be imposed on centrifugal pumps for either hydraulic or mechanical reasons. Four limiting factors must be considered: radial thrust, temperature rise, internal recirculation, and shape of the brake horsepower curve.

Radial thrust is discussed in Subsections 2.2.1 and 2.3.1. For sustained operation, it is imperative to adhere to the minimum flow limits recommended by the pump manufacturer, which depend on the specific design of the pump casing and impeller.

The thermodynamic problem that arises when a centrifugal pump is operated at extremely reduced flows is caused by the heating up of the liquid handled. The difference between the brake horsepower consumed and the water horsepower developed represents the power losses in the pump, except for a small amount lost in the pump bearings. These power losses are converted to heat and transferred to the liquid passing through the pump.

If the pump were to operate against a completely closed valve, the power losses would be equal to the shutoff brake horsepower, and because there would be no flow through the pump, all this power would go into heating the small quantity of liquid contained in the pump casing. The pump casing would heat up, and a certain amount of heat would be dissipated by radiation and convection to the atmosphere. However, because the temperature rise in the liquid pumped could be quite rapid, it is generally safer to ignore the dissipation of heat through radiation and the absorption of heat by the casing. Calculations for determining the temperature rise in the pumped liquid are given in Subsection 2.3.1. The maximum permissible temperature rise in a centrifugal pump varies over a wide range, depending on the type of service and installation. For hot-water pumps, as on boiler-feed service, it is generally advisable to limit the temperature rise to about 15°F (8°C). As a general rule, the minimum permissible flow to hold the temperature rise in boiler-feed pumps to this value is 30 gpm for each 100 bhp (9.13 m<sup>3</sup>/h per 100 kW) at shutoff. When the pump handles cold water, the temperature rise may be permitted to reach 50 or even 100°F (28 or 56°C). The minimum capacity based on thermodynamic considerations is then established as the capacity at which the temperature rise is the maximum permitted. Means and controls used to provide the necessary minimum flows are described in Subsection 2.3.4.

There are also hydraulic considerations that may affect the minimum flow at which a centrifugal pump can operate. In recent years, correlation has been developed between operation at low flows and the appearance of hydraulic pulsations both in the suction and in the discharge of centrifugal impellers. It has been proved that these pulsations are caused by the development of an internal recirculation at the inlet and discharge of an impeller at certain flows below the best-efficiency capacity. This subject is treated in Subsections 2.3.1 and 2.3.2. The pump manufacturer's recommendations on minimum flows dictated by these considerations must be followed.

**Priming** With very few exceptions, no centrifugal pump should ever be started until it is fully primed; that is, until it has been filled with the liquid pumped and all the air contained in the pump has been allowed to escape. The exceptions involve self-priming pumps

and some special large-capacity, low-head, and low-speed installations where it is not practical to prime the pump prior to starting; the priming takes place almost simultaneously with the starting in these cases. For further details, see Section 2.4.

Reciprocating pumps of the piston or plunger type are in principle self-priming. However, if quick starting is required, priming connections should be piped to a supply above the pump.

Positive displacement pumps of the rotating type, such as rotary or screw pumps, have clearances that allow the liquid in the pump to drain back to the suction. When pumping low-viscosity liquids, the pump may completely dry out when it is idle. In such cases a foot valve may be used to help keep the pump primed. Alternately, a vacuum device may be used to prime the pump. When handling liquids of higher viscosity, foot valves are usually not required because liquid is retained in the clearances and acts as a seal when the pump is restarted. However, before the initial start of a rotating positive displacement pump, some of the liquid to be pumped should be introduced through the discharge side of the pump to wet the rotating element.

The various methods and arrangements used for priming pumps are described in Section 2.4.

**Final Checks Before Start-Up** A few final checks are recommended before a pump is placed into service for its initial start. For pumps with journal bearings, the bearing covers should be removed, and the bearings should be flushed and thoroughly cleaned. They should then be filled with new lubricant in accordance with the manufacturer's recommendations.

With the coupling disconnected, the driver should be tested again for correct direction of rotation. Generally an arrow on the pump casing indicates the correct rotation.

It must be possible to rotate the rotor of a centrifugal pump by hand, and in the case of a pump handling hot liquids, the rotor must be free to rotate with the pump cold or hot. If the rotor is bound or even drags slightly, do not operate the pump until the cause of the trouble is determined or corrected.

**Starting and Stopping Procedures** The steps necessary to start a centrifugal pump depend upon its type and upon the service on which it is installed. For example, standby pumps are generally held ready for immediate starting. The suction and discharge gate valves are held open, and reverse flow through the pump is prevented by the check valve in the discharge line.

The methods followed in starting are greatly influenced by the shape of the power-capacity curve of the pump. High- and medium-head pumps (low and medium specific speeds) have power curves that rise from zero flow to the normal capacity condition. Such pumps should be started against a closed discharge valve to reduce the starting load on the driver. A check valve is equivalent to a closed valve for this purpose, as long as another pump is already on the line. The check valve will not lift until the pump being started comes up to a speed sufficient to generate a head high enough to lift the check valve from its seat. If a pump is started with a closed discharge valve, the recirculation bypass line must be open to prevent overheating.

Low-head pumps (high specific speed) of the mixed-flow and propeller type have power curves that rise sharply with a reduction in capacity; they should be started with the discharge valve wide open against a check valve, if required, to prevent backflow.

Assuming that the pump in question is motor-driven, that its shutoff power does not exceed the safe motor power, and that it is to be started against a closed gate valve, the starting procedure is as follows:

1. Prime the pump, opening the suction valve, closing the drains, and so on, to prepare the pump for operation.
2. Open the valve in the cooling supply to the bearings, where applicable.
3. Open the valve in the cooling supply if the seal chambers are liquid-cooled.
4. Open the valve in the sealing liquid supply if the pump is so fitted.

5. Open the warm-up valve of a pump handling hot liquids if the pump is not normally kept at operating temperature. When the pump is warmed up, close the valve.
6. Open the valve in the recirculating line if the pump should not be operated against dead shutoff.
7. Start the motor.
8. Open the discharge valve slowly.
9. For pumps equipped with mechanical seals, check for seal leakage: there should be none.
10. For pump with shelf packing, observe the leakage from the stuffing boxes and adjust the sealing liquid valve for proper flow to ensure the lubrication of the packing. If the packing is new, do not tighten up on the gland immediately, but let the packing run in before reducing the leakage through the stuffing boxes.
11. Check the general mechanical operation of the pump and motor.
12. Close the valve in the recirculating line when there is sufficient flow through the pump to prevent overheating.

If the pump is to be started against a closed check valve with the discharge gate valve open, the steps are the same, except that the discharge gate valve is opened some time before the motor is started.

In certain cases, cooling to the bearings and flush liquid to the mechanical seals or to the packing seal cages is provided by the pump. This, of course, eliminates the need for the steps listed for the cooling and sealing supply.

Just as in starting a pump, the stopping procedure depends upon the type and service of the pump. Generally, the steps followed to stop a pump that can operate against a closed gate valve are

1. Open the valve in the recirculating line.
2. Close the gate valve.
3. Stop the motor.
4. Open the warm-up valve if the pump is to be kept at operating temperature.
5. Close the valve in the cooling supply to the bearings and seal chambers.
6. If the sealing liquid supply is not required while the pump is idle, close the valve in this supply line.
7. Close the suction valve, open the drain valves, and so on, as required by the particular installation or if the pump is to be opened up for inspection.

If the pump is of a type that does not permit operation against a closed gate valve, steps 2 and 3 are reversed.

In general, the starting and stopping of steam-turbine-driven pumps require the same steps and sequence prescribed for a motor-driven pump. As a rule, steam turbines have various drains and seals that must be opened or closed before and after operation. Similarly, many turbines require warming up before starting. Finally, some turbines require turning gear operation if they are kept on the line ready to start up. The operator should therefore follow the steps outlined by the turbine manufacturer in starting and stopping the turbine.

Most of the steps listed for starting and stopping centrifugal pumps are equally applicable to positive displacement pumps. There are, however, two notable exceptions:

1. Never operate a positive displacement pump against a closed discharge. If the gate valve on the discharge must be closed, always start the pump with the recirculation bypass valve open.
2. Always open the steam cylinder drain cocks of a steam reciprocating pump before starting, to allow condensate to escape and to prevent damage to the cylinder heads.

**Auxiliary Services on Standby Pumps** Standby pumps are frequently started up from a remote location, and several methods of operation are available for the auxiliary services, such as the cooling supply to bearings or seal chambers:

1. A constant flow may be kept through jackets or oil coolers and through stuffing box lantern rings or seal chambers whether the pump is running or on standby service.
2. The service connections may be opened automatically whenever the pump is started up.
3. The service connections may be kept closed while the pump is idle, and the operator may be instructed to open them shortly after the pump has been put on the line automatically.

The choice among these methods must be dictated by the specific circumstances surrounding each case. There are, however, certain cases where sealing liquid supply to the pump seal chambers must be maintained whether the pump is running or not. This is the case when the pump handles a liquid that is corrosive or that may crystallize and deposit on the sealing components. It is also the case when the sealing supply is used to prevent air infiltration into a pump when it is operating under a vacuum.

**Restarting Motor-Driven Pumps After Power Failure** Assuming that power failure will not cause the pump to go into reverse rotation; that is, that a check valve will protect the pump against reverse flow, there is generally no reason why the pump should not be permitted to restart after current has been re-established. Whether the pump will start again automatically when power is restored will depend on the type of motor control used. (Subsection 2.3.1 and Section 8.1 give reasons why some pumps should not be started in reverse.)

Because pumps operating on a suction lift may lose their prime during the time that power is off, it is preferable to use starters with low load protection for such installations to prevent an automatic restart. This does not apply, of course, if the pumps are automatically primed or if some protection device is incorporated so the pump cannot run unless it is primed.

## **MAINTENANCE**

---

Because of the wide variation in pump types, sizes, designs, and materials of construction, these comments on maintenance are restricted to those types of pumps most commonly encountered. The manufacturer's instruction books must be carefully studied before any attempt is made to service a particular pump.

**Daily Observation of Pump Operation** When operators are on constant duty, hourly and daily inspections should be made and any irregularities in the operation of a pump should be recorded and reported immediately. This applies particularly to changes in sound of a running pump, abrupt changes in bearing temperatures, and seal chamber leakage. A check of pressure gages and of flowmeters, if installed, and vibration should be made routinely during the day. If recording instruments are provided, a daily check should be made to determine whether the current capacity, pressure, power consumption or vibration level indicates that further inspection is required. If these readings are taken electronically, trending charts should be produced to allow observation of changes as a function of time. Certain trends may allow for scheduled outages to address deterioration of specific performance values.

**Semiannual Inspection** The following should be done at least every six months:

1. For pumps equipped with shaft packing, the free movement of stuffing box glands should be checked, gland bolts should be cleaned and lubricated, and the packing should be inspected to determine whether it requires replacement.
2. The pump and driver alignment should be checked and corrected if necessary.
3. Housings for oil-lubricated bearings should be drained, flushed, and refilled with fresh oil.
4. Grease-lubricated bearings should be checked to see that they contain the correct amount of grease and that it is still of suitable consistency.

**Annual Inspection** A very thorough inspection should be performed once a year. In addition to the semiannual procedure, the following items should be considered:

1. Vibration trends should be reviewed. If the pump is trending toward unacceptable vibration levels,
  - a. The bearings should be removed, cleaned, and examined for flaws and wear.
  - b. The bearing housings should be carefully cleaned.
  - c. Rolling element bearings should be examined for scratches and wear.
  - d. Immediately after cleaning, rolling element bearings that are considered acceptable for reinstallation should be coated with oil or grease. *Note:* If there is any sign of damage, or if the bearings were damaged during removal, they should be replaced with new bearings of the correct size and type per the manufacturer's instruction book.
  - e. The assembled rotor—or major rotor components if the rotor is not assembled of shrink-fit components—should be checked for balance prior to reassembly in the pump.
2. For pumps equipped with shaft packing, the packing should be removed and the shaft sleeves—or shaft, if no sleeves are used—should be examined for wear.
3. For pumps equipped with mechanical seals, if the seals were indicating signs of leaking, they should be removed and returned to the seal manufacturer for inspection, possible bench testing, and refurbishment.
4. When coupling halves are disconnected for an alignment check, the vertical shaft movement of a pump with sleeve (journal) bearings should be checked at both ends with packing or seals removed. Any movement exceeding 150% of the original design clearance should be investigated to determine the cause. Endplay allowed by the bearings should also be checked. If it exceeds that recommended by the manufacturer, the cause should be determined and corrected.
5. All auxiliary piping, such as drains, sealing water piping, and cooling water piping, should be checked and flushed, as necessary. Auxiliary coolers should also be flushed and cleaned.
6. Pump equipped with stuffing boxes should be repacked, and the pump and driver should be realigned and reconnected.
7. All instruments and flow-metering devices should be recalibrated, whenever feasible, and—whenever possible—the pump should be tested to determine whether proper performance is being obtained. If internal repairs are made, the pump should again be tested after completion of the repairs.

**Complete Overhaul** It is difficult to make general rules about the frequency of complete pump overhauls as it depends on the pump service, the pump construction and materials, the liquid handled, and the economic evaluation of overhaul costs versus the cost of power losses resulting from increased clearances or of unscheduled downtime. Some pumps on very severe service may need a complete overhaul monthly, whereas other applications require overhauls only every two to four years or even less frequently.



A pump should not be opened for inspection unless either factual or circumstantial evidence indicates that overhaul is necessary. Factual evidence implies that the pump performance has fallen off significantly or that the noise or driver load indicates trouble. Circumstantial evidence refers to past experience with the pump in question or with similar equipment on similar service.

In order to ensure rapid restoration to service in the event of an unexpected overhaul, an adequate store of spare parts should be maintained at all times.

The relative complexity of the repairs, the facilities available at the site, and many other factors enter into the decision whether the necessary repairs will be carried out at the installation site or at the pump manufacturer's plant.

**Spare and Repair Parts** The severity of the service in which the pump is used will determine, to a great extent, the minimum number of spare parts that should be carried in stock at the installation site. Unless prior experience is available, the pump manufacturer should be consulted on this subject. As an insurance against delays, spare parts should be purchased when the pump is purchased. Depending on the contemplated method of overhaul, certain replacement parts may have to be supplied either oversized or undersized instead of the size used in the original unit.

API Standard 610, 8th edition, shows recommended spare parts as a function of the number of identical pumps installed at a site. It also lists parts usually associated with start-up and with normal maintenance. A form based on the recommendations of API Standard 610 is shown in Table 1.

When ordering spare parts after a pump has been in service, the manufacturer should always be given the pump serial number and size (stamped on the nameplate). This information is essential in identifying the pump exactly and in furnishing repair parts of correct size and material.

**Records of Inspections and Repairs** The working schedule of the semiannual and annual inspections should be entered into a log that tracks individual pump maintenance history. This log should then contain a complete record of all the items requiring attention. This log, usually electronic, should also contain comments and observations on the conditions of the parts to be repaired or replaced, on the rate and appearance of wear, and on the repair methods followed. In many cases, it is advisable to photograph badly worn parts before they are repaired.

In all cases, complete records of the cost of maintenance and repairs should be kept for each pump, together with a record of its operating hours. A study of these records will generally reveal whether a change in materials or even construction may be the most economical course of action to improve pump performance, reliability, and life.

**Diagnosis of Pump Problems** Pump operating problems may be either hydraulic or mechanical. In the first category, a pump may fail to deliver liquid, it may deliver an insufficient capacity or develop insufficient pressure, or it may lose its prime after starting. In the second category, it may consume excessive power, or symptoms of mechanical difficulties may develop at the seal chambers or at the bearings, or vibration, noise, or breakage of some pump parts may occur.

There is a definite interdependence between some difficulties of both categories. For example, increased wear at the running clearances must be classified as a mechanical trouble, but it will result in a reduction of the net pump capacity—a hydraulic symptom—without necessarily causing a mechanical breakdown or even excessive vibration. As a result, it is most useful to classify symptoms and causes separately and to list for each symptom a schedule of potential contributory causes. Such a diagnostic analysis is presented in Tables 2 through 5. Additionally, the following parts of this handbook should also be referred to for assistance in diagnosing pump hydraulic and mechanical problems and possible solutions: Subsections 2.2.2, 2.2.3, 2.3.2, and 2.3.3 and Sections 3.4 and 8.4.

**TABLE 1** Recommended spare parts

Part	See Note	Spares Recommended						
		Start-up			Normal Maintenance			
		1-3	4-6	7+	1-3	4-6	7-9	10+
Number of identical pumps								
Cartridge	(2) (5)				1	1	1	1
Element	(2) (6)				1	1	1	1
Rotor	(3) (7)				1	1	1	1
Case	(1)							1
Head (case cover and seal chamber)								1
Bearing bracket	(1)							1
Shaft (w/key)					1	1	2	N/3
Impeller					1	1	2	N/3
Wear rings (set)	(8)	1	1	1	1	1	2	N/3
Bearings complete (rolling element, radial)	(1) (9)	1	1	2	1	2	N/3	N/3
Bearings complete (rolling element, thrust)	(1) (9)	1	1	2	1	2	N/3	N/3
Bearings complete (hydrodynamic, radial)	(1) (9)	1	1	2	1	2	N/3	N/3
Bearing pads only (hydrodynamic, radial)	(1) (9)	1	1	2	1	2	N/3	N/3
Bearing complete (hydrodynamic, thrust)	(1) (9)	1	1	2	1	2	N/3	N/3
Bearing pads only (hydrodynamic, thrust)	(1) (9)	1	1	2	1	2	N/3	N/3
Mechanical seal/packing	(4) (8) (9)	1	2	N/3	1	2	N/3	N/3
Shaft sleeve	(8)	1	2	N/3	1	2	N/3	N/3
Gaskets, shims, O-rings (set)	(8)	1	2	N/3	1	2	N/3	N/3
Add for vertical pump								
Bowls							N/3	N/3
Spiders (set)				1	1	1	N/3	N/3
Bearings, bushings (set)		1	1	2	1	1	N/3	N/3
Add for high speed integral gear								
Gear box			1	1	1	1	1	N/3
Diffuser and cover		1	1	1	1	1	1	N/3
Splined shaft		1	1	1	1	1	1	N/3
Gear box housing					1	1	1	N/3
Oil pump, internal			1	1	1	1	1	N/3
Oil pump, external			1	1	1	1	1	N/3
Oil filter		1	2	N/3	1	2	3	N/3

## Notes:

N = Number of identical pumps

(1) Horizontal pumps only

(2) Vital service pumps are generally unspared, partially spared, or multistage. When a vital machine is down, production loss or violation of environmental permits results.

(3) Essential service pumps are required for operation and have an installed spare. A production loss will occur only if main and spare fail simultaneously.

(4) Cartridge type mechanical seals shall include sleeve and gland.

(5) Cartridge consists of assembled element plus discharge head, seal(s), and bearing housing(s).

(6) Element consists of assembled rotor plus stationary hydraulic parts (diffuser(s) or volute(s)).

(7) Rotor consists of all rotating parts attached to the shaft.

(8) Normal wear parts

(9) Per pump set

**TABLE 2A** Check chart for centrifugal pump problems

Symptoms	Possible cause of trouble (each number is defined in Table 2B)
1. Pump does not deliver liquid	1, 2, 3, 5, 10, 12, 13, 14, 16, 21, 22, 25, 30, 32, 38, 40
2. Insufficient capacity delivered	2, 3, 4, 5, 6, 7, 7a, 10, 11, 12, 13, 14, 15, 16, 17, 18, 21, 22, 23, 24, 25, 31, 32, 40, 41, 44, 63, 64
3. Insufficient pressure developed	4, 6, 7, 7a, 10, 11, 12, 13, 14, 15, 16, 18, 21, 22, 23, 24, 25, 34, 39, 40, 41, 63, 64
4. Pump loses prime after starting	2, 4, 6, 7, 7a, 8, 9, 10, 11
5. Pump requires excessive power	20, 22, 23, 24, 26, 32, 33, 34, 35, 39, 40, 41, 44, 45, 61, 69, 70, 71
6. Pump vibrates or is noisy at all flows	2, 16, 37, 43, 44, 45, 46, 47, 48, 49, 50, 51, 52, 53, 54, 55, 56, 57, 58, 59, 60, 61, 67, 78, 79, 80, 81, 82, 83, 84, 85
7. Pump vibrates or is noisy at low flows	2, 3, 17, 19, 27, 28, 29, 35, 38, 77
8. Pump vibrates or is noisy at high flows	2, 3, 10, 11, 12, 13, 14, 15, 16, 17, 18, 33, 34, 41
9. Shaft oscillates axially	17, 18, 19, 27, 29, 35, 38
10. Impeller vanes are eroded on visible side	3, 12, 13, 14, 15, 17, 41
11. Impeller vanes are eroded on invisible side	12, 17, 19, 29
12. Impeller vanes are eroded at discharge near center	37
13. Impeller vanes are eroded at discharge near shrouds or at shroud/vane fillets	27, 29
14. Impeller shrouds bowed out or fractured	27, 29
15. Pump overheats and seizes	1, 3, 12, 28, 29, 38, 42, 43, 45, 50, 51, 52, 53, 54, 55, 57, 58, 59, 60, 61, 62, 77, 78, 82
16. Internal parts are corroded prematurely	66
17. Internal clearances wear too rapidly	3, 28, 29, 45, 50, 51, 52, 53, 54, 55, 57, 59, 61, 62, 66, 77
18. Axially-split casing is cut through wire-drawing	63, 64, 65
19. Internal stationary joints are cut through wire-drawing	53, 63, 64, 65
20. Packed box leaks excessively or packing has short life	8, 9, 45, 55, 57, 68, 69, 70, 71, 72, 73, 74
21. Packed box: sleeve scored	8, 9
22. Mechanical seal leaks excessively	45, 54, 55, 57, 58, 62, 75, 76
23. Mechanical seal: damaged faces, sleeve, bellows	45, 54, 55, 57, 58, 62, 75, 76
24. Bearings have short life	3, 29, 41, 42, 45, 50, 51, 54, 55, 58, 77, 78, 79, 80, 81, 82, 83, 84, 85
25. Coupling fails	45, 50, 51, 54, 67

**TABLE 2B** Possible causes of problems**Suction Problems**

1. Pump not primed
2. Pump suction pipe not completely filled with liquid
3. Insufficient available NPSH
4. Excessive amount of air or gas in liquid
5. Air pocket in suction line
6. Air leaks into suction line
7. Air leaks into pump through stuffing boxes or through mechanical seal
- 7a. Air in source of sealing liquid
8. Water seal pipe plugged
9. Seal cage improperly mounted in stuffing box
10. Inlet of suction pipe insufficiently submerged
11. Vortex formation at suction
12. Pump operated with closed or partially closed suction valve
13. Clogged suction strainer
14. Obstruction in suction line
15. Excessive friction losses in suction line
16. Clogged impeller
17. Suction elbow in plane parallel to the shaft (for double-suction pumps)
18. Two elbows in suction piping at 90° to each other, creating swirl and prerotation
19. Selection of pump with too high a suction specific speed

**Other Hydraulic Problems**

20. Speed of pump too high
21. Speed of pump too low
22. Wrong direction of rotation
23. Reverse mounting of double-suction impeller
24. Uncalibrated instruments
25. Impeller diameter smaller than specified
26. Impeller diameter larger than specified
27. Impeller selection with abnormally high head coefficient
28. Running the pump against a closed discharge valve without opening a by-pass
29. Operating pump below recommended minimum flow
30. Static head higher than shut-off head

**Other Hydraulic Problems (continued)**

31. Friction losses in discharge higher than calculated
32. Total head of system higher than design of pump
33. Total head of system lower than design of pump
34. Running pump at too high a flow (for low specific speed pumps)
35. Running pump at too low a flow (for high specific speed pumps)
36. Leak of stuck check valve
37. Too close a gap between impeller vanes and volute tongue or diffuser vanes
38. Parallel operation of pumps unsuitable for the purpose
39. Specific gravity of liquid differs from design conditions
40. Viscosity of liquid differs from design conditions
41. Excessive wear at internal running clearances
42. Obstruction in balancing device leak-off line
43. Transients at suction source (imbalance between pressure at surface of liquid and vapor pressure at suction flange)

**Mechanical Problems—general**

44. Foreign matter in impellers
45. Misalignment
46. Foundation insufficiently rigid
47. Loose foundation bolts
48. Loose pump or motor bolts
49. Inadequate grouting of baseplate
50. Excessive piping forces and moments on pump nozzles
51. Improperly mounted expansion joints
52. Starting the pump without proper warm-up
53. Mounting surfaces of internal fits (at wearing rings, impellers, shaft sleeves, shaft nuts, bearing housings, and so on) not perpendicular to shaft axis
54. Bent shaft
55. Rotor out of balance
56. Parts loose on the shaft
57. Shaft running off-center because of worn bearings

**TABLE 2B** Continued.

<b>Mechanical Problems—general (continued)</b>	<b>Mechanical Problems—sealing area (continued)</b>
58. Pump running at or near critical speed	73. Dirt or grit in sealing liquid
59. Too long a shaft span or too small a shaft diameter	74. Failure to provide adequate cooling liquid to water-cooled stuffing boxes
60. Resonance between operating speed and natural frequency of foundation, baseplate, or piping	75. Incorrect type of mechanical seal for prevailing conditions
61. Rotating part rubbing on stationary part	76. Mechanical seal improperly installed
62. IncurSION of hard solid particles into running clearances	<b>Mechanical Problems—bearings</b>
63. Improper casing gasket material	77. Excessive radial thrust in single-volute pumps
64. Inadequate installation of gasket	78. Excessive axial thrust caused by excessive wear at internal clearances or, if used, failure or excessive wear of balancing drive
65. Inadequate tightening of casing bolts	79. Wrong grade of grease or oil
66. Pump materials not suitable for liquid handled	80. Excessive grease or oil in rolling element bearing housings
67. Certain couplings lack lubrication	81. Lack of lubrication
<b>Mechanical Problems—sealing area</b>	82. Improper installation of rolling element bearings such as damage during installation, incorrect assembly of stacked bearings, use of unmatched bearings as a pair, and so on
68. Shaft or shaft sleeves worn or scored at packing	83. Dirt getting into bearings
69. Incorrect type of packing for operating conditions	84. Moisture contaminating lubricant
70. Packing improperly installed	85. Excessive cooling of water-cooled bearings
71. Gland too tight, prevents flow of liquid to lubricate packing	
72. Excessive clearance at bottom of stuffing box allows packing to be forced into pump interior	

**TABLE 2C** Diagnosis from appearance of stuffing box packing in centrifugal pumps

Symptom	Cause
Wear on one or two rings next to packing gland; other rings OK	Improper packing installation
Wear on O.D. of packing rings	Packing rings rotating with shaft sleeve or leakage between rings and I.D. of box. Wrong packing size or incorrectly cut rings
Charring or glazing of inner circumference of rings	Excessive heating. Insufficient leakage to lubricate packing or unsuitable packing
I.D. of rings excessively increased or heavily worn on part of inner circumference	Rotation eccentric

**TABLE 2D** Vibration symptoms and causes in centrifugal pumps

Vibration frequency	Cause
Several times pump RPM	Bad rolling element bearings
Twice pump RPM	Loose parts on rotor, axial misalignment of coupling, influence of twin-volute when gap is insufficient
Running Speed	Imbalance of rotor, clogged impeller, coupling misaligned or loose
Running speed times number of impeller vanes	Vane passing syndrome—insufficient gap between impeller vanes and collector vanes. This is also sometimes seen during operating with suction recirculation.
One-half running speed	Oil whirl in bearing
Random low frequency	Internal circulation in impeller or cavitation
Random high frequency	Usually resonance
Subsynchronous frequency at 70% to 90% of running speed	Hydraulic excitation of resonance

**TABLE 3** Check chart for rotary pump problems

Symptom	Possible cause of trouble (each number is defined in the list below)
Pump fails to discharge	1, 2, 3, 4, 5, 6, 8, 9, 16
Pump is noisy	6, 10, 11, 17, 18, 19
Pump wears rapidly	11, 12, 13, 20, 24
Pump not up to capacity	3, 5, 6, 7, 9, 16, 21, 22
Pump starts, then loses suction	1, 2, 6, 7, 10
Pump takes excessive power	14, 15, 17, 20, 23
<b>Suction problems</b>	System problems (continued)
1. Pump not properly primed	13. Pump runs dry
2. Suction pipe not submerged	14. Viscosity higher than specified
3. Strainer clogged	15. Obstruction in discharge line
4. Foot valve leaking	
5. Suction lift too high	<b>Mechanical troubles</b>
6. Air leaking into suction	16. Pump worn
7. Suction pipe too small	17. Drive shaft bent
	18. Coupling out of balance or alignment
<b>System problems</b>	19. Relief valve chatter
8. Wrong direction of rotation	20. Pipe strain on pump casing
9. Low speed	21. Air leak at packing or seal
10. Insufficient liquid supply	22. Relief valve improperly seated
11. Excessive pressure	23. Packing too tight
12. Grit or dirt in liquid	24. Corrosion

**TABLE 4** Check chart for reciprocating pump problems

Symptom	Possible cause of problem (each number is defined in the list below)
Liquid end noise	1, 2, 7, 8, 9, 10, 14, 15, 16
Power end noise	17, 18, 19, 20
Overheated power end	10, 19, 21, 22, 23, 24
Water in crankcase	25
Oil leak from crankcase	26, 27
Rapid packing or plunger wear	11, 12, 28, 29
Pitted valves or seats	3, 11, 30
Valves hanging up	31, 32
Leak at cylinder valve hole plugs	10, 13, 33, 34
Loss of prime	1, 4, 5, 6
<b>Suction problems</b>	<b>Mechanical problems</b>
1. Insufficient suction pressure	14. Valves broken or badly worn
2. Partial loss of prime	15. Packing worn
3. Cavitation	16. Obstruction under valve
4. Lift too high	17. Main bearings loose
5. Leaking suction at foot valve	18. Bearings worn
6. Acceleration head requirement too high	19. Oil level low
	20. Plunger loose
	21. Main bearings tight
	22. Ventilation inadequate
<b>System problems</b>	23. Belts too tight
7. System shocks	24. Driver misaligned
8. Poorly supported piping, abrupt turns in piping, pipe too small, piping misaligned	25. Condensation
9. Air in liquid	26. Seals worn
10. Overpressure or overspeed	27. Oil level too high
11. Dirty liquid	28. Pump not level and rigid
12. Dirty environment	29. Packing loose
13. Water hammer	30. Corrosion
	31. Valve binding
	32. Valve spring broken
	33. Cylinder plug loose
	34. O-ring seal damaged

**TABLE 5** Check chart for steam-pump problems

Symptoms	Possible cause of problem (each number is defined in the list below)
Pump does not develop rated pressure	4, 5, 7, 8
Pump loses capacity after starting	1, 2, 6
Pump vibrates	9, 10, 11, 14
Pump has short strokes	12, 13, 14
Pump operation is erratic	1, 2, 3, 6
<b>Suction problems</b>	<b>Mechanical problems</b>
1. Suction line leaks	7. Worn piston rings in steam end
2. Suction lift too high	8. Binding piston rings in liquid end
3. Cavitation	9. Misalignment
	10. Foundation not rigid
<b>System problems</b>	11. Piping not supported
4. Low steam pressure	12. Excessive steam cushioning
5. High exhaust pressure	13. Steam valves out of adjustment
6. Entrained air or vapors in liquid	14. Liquid piston packing too tight

**FURTHER READING**

1. American Petroleum Institute. "Centrifugal Pumps for Refinery, Heavy Duty Chemical, and Gas Industry Services." API Standard 610, 8th ed., 1220 L Street, Washington, DC, 20005, 1995, [www.api.org](http://www.api.org).
2. American Petroleum Institute. API Recommended Practice 686 (PIP REIE 686), "Recommended Practices for Machinery Installation and Installation Design." 1st ed., 1220 L Street, Washington, DC, 20005, 1996, [www.api.org](http://www.api.org).
3. Dufour, J. W., and Nelson, W. E. *Centrifugal Pump Sourcebook*. McGraw-Hill, Inc., New York, 1992.
4. Heald, C. C., and Penry, D. G. "Design and Operation of Pumps for Hot Standby Service." 5th International Pump Users Symposium, Texas A&M, Houston, TX 1988.
5. Hydraulic Institute ANSI/HI 2000 Edition Pump Standards, Hydraulic Institute, Parsippany, NJ, [www.pumps.org](http://www.pumps.org).
6. Karassik, I. J. *Centrifugal Pump Clinic*. Marcel Dekker, New York, 1981.



# **PUMP TESTING**

**Wesley W. Beck**

Since the first time a device was used to pump or lift water, pump testing of one sort or another has occurred. Each improvement in pumping devices was accepted only after being tested, which was the proof of its worthiness. As pumping equipment has become more refined, so has the art of pump testing, both in the shop or laboratory and in the field. For very large pumps, model testing is being used to develop the optimum refinement in prototype design.

Every pump, regardless of size or classification, should be tested in some way before final acceptance by the purchaser. If not, the user does not have any way of knowing that all requirements have been fulfilled. What tests to run and what methods to use depend on the ultimate purpose of the tests, which normally have one of two objectives:

1. To check improvement in design or operation
2. To determine if contractual commitments have been met, thus making possible the comparison of specified, predicted, and actual performance

In most cases, the manufacturer supplies a test report and certifies the characteristics of the pump being furnished. Even these can be given a cursory check by the customer from time to time to give a record of performance or an indication of the need for replacement or overhaul. If at all possible, the pump should be tested as installed, with repeat tests from time to time to check operation.

The main object of this chapter is to present a set of procedures and rules for conducting, computing, and reporting on tests of pumping units and for obtaining the head, capacity, power, efficiency, and suction requirements of a pump.

## **CLASSIFICATION OF TESTS**

---

Pump tests should be classified as follows:

- *Shop tests* are also called laboratory, manufacturer's, or factory acceptance tests. They are conducted in the pump manufacturer's plant under geometrically similar, ideal, and controlled conditions and are usually assumed to be the most accurate tests.
- *Field tests* are made with the pumping unit installed in its exact environment and operating under existing field or ultimate conditions. The accuracy and reliability of field testing depend on the instrumentation used, installation, and advance planning during the design stages of the installation. By mutual agreement, field tests can be used as acceptance tests.
- *Index tests* are a form of field testing usually made to serve as a standard of comparison for wear, changing conditions, or overhaul evaluation. Index tests should always be run using the same procedures, instruments, and personnel where possible, and a very accurate record and log of events should be kept to give as complete and comparable a history of the results as possible.
- *Model tests* precede the design of the prototype and are usually quite accurate. They supplement or complement field tests of the prototype for which the model was made. The role of the model test must be clearly established as early in the design as possible, preferably in the specification or invitation to bid. Model tests may be used when very large units are involved, when the performances of several models must be compared, and when an advance indication of prototype design is required.

## DEFINITIONS, SYMBOLS, AND UNITS

For a detailed discussion of letter symbols, definitions, description of terms, and table of letter symbols in general use, the user is referred to ASME Power Test Code<sup>1</sup> and to "SI Units—A Commentary" in front matter of this handbook.

**Standard Units Used in Pump Testing** The following definitions and quantities from the Hydraulic Institute standards<sup>2</sup> are used throughout the industry in pump testing.

**VOLUME** The standard units of volume are the U.S. gallon and the cubic foot (cubic meter). The standard U.S. gallon contains 231.0 in<sup>3</sup> (0.00379 m<sup>3</sup>), and 1 ft<sup>3</sup> = 7.4805 gal (0.028 m<sup>3</sup>). Rate of flow is expressed in gallons per minute (cubic meters per hour), cubic feet per second, or million gallons per 24-h day. The specific weight (mass)  $w$  of pure water at 68°F (20°C), at sea level and 40° latitude, is 62.315 lb/ft<sup>3</sup> (0.998 kg/liter). For other temperatures or locations, proper specific weight corrections should be made. See Table 1 and the appropriate ASME power test codes.

**HEAD** The unit for measuring head is the foot (meter). The relation between a pressure expressed in pounds per square inch (kilopascals) and one expressed in feet (meters) of head is

$$\text{in USCS units} \quad \text{head, ft} = \text{lb/in}^2 \times \frac{144}{w}$$

$$\text{in SI units} \quad \text{Head, m} = \text{kPa} \times \frac{0.102}{w}$$

where  $w$  = specific weight of liquid being pumped under pumping conditions, lb/ft<sup>3</sup> (kg/l)

All pressure readings must be converted to feet (meters) of the liquid being pumped, referenced to a datum elevation, which is defined as follows. For a horizontal shaft unit, the datum elevation is the centerline of the pump shaft (Figure 1). For vertical-shaft single-suction pumps, it is the entrance eye to the first-stage impeller (Figure 2). For vertical-shaft double-suction pumps, it is the impeller-discharge horizontal centerline (Figure 3).

**VELOCITY HEAD** The velocity head  $h_v$  is computed from the average velocity  $V$ , obtained by dividing the flow by the pipe cross-sectional area. Velocity head is determined at the point of gage connection and is expressed by the formula

$$h_v = \frac{V^2}{2g}$$

where  $V$  = velocity in the pipe, ft/s (m/s)

$g$  = acceleration due to gravity = 32.17 ft/s<sup>2</sup> (9.81 m/s<sup>2</sup>) (Table 2)

**FLOODED SUCTION** Flooded suction implies that the liquid must flow from an atmospherically vented source to the pump without the average or minimum pressure at the pump datum dropping below atmospheric pressure with the pump operating at specified capacity.

**TOTAL SUCTION LIFT** Suction lift exists where the total suction head is below atmospheric pressure. Total suction lift  $h_s$  is the reading of a liquid manometer or pressure gage at the suction nozzle of the pump, converted to feet (meters) of liquid, and referred to datum minus the velocity head at the point of gage attachment.

**TOTAL SUCTION HEAD** Suction head exists when the total suction head  $h_s$  is above atmospheric pressure. Total suction head is the reading of a gage at the suction of the pump converted to feet (meters) of liquid and referred to datum plus the velocity head at the point of gage attachment.

**TOTAL DISCHARGE HEAD** Total discharge head  $h_d$  is the reading of a pressure gage at the discharge of the pump, converted to feet (meters) of liquid and referred to datum plus the velocity head at the point of gage attachment.

**TOTAL HEAD** Total head  $H$  is the measure of the work increase per pound kilogram of liquid, imparted to the liquid by the pump, and is therefore the algebraic difference between the total discharge head and the total suction head. Total head, as determined on test where suction lift exists, is the sum of the total discharge head and total suction lift. Where positive suction head exists, the total head is the total discharge head minus the total suction head.

**TABLE 1** Specific weight of water in air

Latitude	Temperature, °F (°C)							
	32 (0)	40 (4.4)	50 (10)	60 (16)	70 (21)	80 (27)	90 (32)	100 (38)
At sea level								
0°	62.1741	62.1823	62.1654	62.1227	62.0578	61.9729	61.8701	61.7514
10	62.1840	62.1921	62.1753	62.1325	62.0677	61.9828	61.8800	61.7612
20	62.2125	62.2206	62.2038	62.1610	62.0961	62.0112	61.9083	61.7895
30	62.2562	62.2643	62.2475	62.2046	62.1397	62.0547	61.9518	61.8328
40	62.3098	62.3179	62.3011	62.2582	62.1932	62.1082	62.0051	61.8861
50	62.3670	62.3751	62.3582	62.3153	62.2503	62.1652	62.0620	61.9429
60	62.4208	62.4289	62.4120	62.3691	62.3040	62.2188	62.1156	61.9963
70	62.4647	62.4728	62.4559	62.4130	62.3478	62.2626	62.1593	62.0399
At 2000 ft								
0°	62.1665	62.1747	62.1578	62.1151	62.0502	61.9654	61.8626	61.7438
10	62.1764	62.1845	62.1677	62.1250	62.0601	61.9752	61.8724	61.7537
20	62.2049	62.2130	62.1962	62.1534	62.0885	62.0036	61.9008	61.7819
30	62.2486	62.2567	62.2399	62.1970	62.1321	62.0471	61.9442	61.8253
40	62.3022	62.3103	62.2935	62.2506	62.1856	62.1006	61.9976	61.8786
50	62.3594	62.3675	62.3506	62.3078	62.2427	62.1576	62.0545	61.9354
60	62.4132	62.4213	62.4044	62.3615	62.2964	62.2112	62.1080	61.9888
70	62.4571	62.4652	62.4484	62.4054	62.3402	62.2550	62.1517	62.0324
At 4000 ft								
0°	62.1588	62.1669	62.1501	62.1073	62.0424	61.9576	61.8549	61.7361
10	62.1686	62.1767	62.1599	62.1172	62.0523	61.9675	61.8647	61.7459
20	62.1971	62.2052	62.1884	62.1456	62.0807	61.9959	61.8930	61.7742
30	62.2408	62.2489	62.2321	62.1893	62.1243	62.0394	61.9365	61.8176
40	62.2944	62.3025	62.2857	62.2428	62.1779	62.0929	61.9899	61.8709
50	62.3516	62.3597	62.3429	62.3000	62.2349	62.1498	62.0467	61.9277
60	62.4054	62.4135	62.3967	62.3537	62.2886	62.2035	62.1003	61.9811
70	62.4493	62.4574	62.4406	62.3976	62.3325	62.2472	62.1440	62.0247
At 6000 ft								
0°	62.1508	62.1589	62.1421	62.0993	62.0345	61.9497	61.8469	61.7282
10	62.1607	62.1688	62.1520	62.1092	62.0444	61.9595	61.8568	61.7380
20	62.1891	62.1972	62.1804	62.1377	62.0728	61.9879	61.8851	61.7663
30	62.2328	62.2409	62.2241	62.1813	62.1164	62.0315	61.9286	61.8097
40	62.2864	62.2945	62.2777	62.2349	62.1699	62.0849	61.9819	61.8630
50	62.3436	62.3517	62.3349	62.2920	62.2270	62.1419	62.0388	61.9198
60	62.3974	62.4055	62.3887	62.3458	62.2807	62.1955	62.0924	61.9732
70	62.4413	62.4495	62.4326	62.3896	62.3245	62.2393	62.1361	61.0168

TABLE 1 Continued.

Latitude	Temperature, °F (°C)							
	32 (0)	40 (4.4)	50 (10)	60 (16)	70 (21)	80 (27)	90 (32)	100 (38)
At 8000 ft								
0°	62.1426	62.1507	62.1339	62.0912	62.0264	61.9416	61.8388	61.7201
10	62.1525	62.1606	62.1438	62.1011	62.0362	61.9514	61.8487	61.7300
20	62.1810	62.1891	62.1723	62.1295	62.0646	61.9798	61.8770	61.7582
30	62.2246	62.2328	62.2159	62.1731	62.1082	62.0233	61.9205	61.8016
40	62.2783	62.2864	62.2696	62.2267	62.1618	62.0768	61.9738	61.8549
50	62.3354	62.3436	62.3267	62.2838	62.2188	62.1338	62.0307	61.9117
60	62.3893	62.3974	62.3805	62.3376	62.2725	62.1874	62.0843	61.9651
70	62.4332	62.4413	62.4244	62.3815	62.3164	62.2312	62.1280	62.0087
At 10,000 ft								
0°	62.1343	62.1424	62.1256	62.0828	62.0180	61.9333	61.8305	61.7119
10	62.1442	62.1523	62.1355	62.0927	62.0279	61.9431	61.8404	61.7217
20	62.1726	62.1807	62.1639	62.1212	62.0563	61.9715	61.8687	61.7500
30	62.2163	62.2244	62.2076	62.1648	62.0999	62.0150	61.9122	61.7934
40	62.2699	62.2781	62.2612	62.2184	62.1534	62.0685	61.9656	61.8466
50	62.3271	62.3352	62.3184	62.2755	62.2105	62.1255	62.0224	61.9034
60	62.3809	62.3890	62.3722	62.3293	62.2642	62.1791	62.0760	61.9568
70	62.4248	62.4330	62.4161	62.3732	62.3080	62.2229	62.1197	62.0005
At 12,000 ft								
0°	62.1258	62.1339	62.1171	62.0743	62.0095	61.9248	61.8221	61.7035
10	62.1357	62.1438	62.1270	62.0842	62.0194	61.9347	61.8319	61.7133
20	62.1641	62.1722	62.1554	62.1127	62.0478	61.9630	61.8603	61.7416
30	62.2078	62.2159	62.1991	62.1563	62.0914	62.0066	61.9037	61.7849
40	62.2614	62.2695	62.2527	62.2099	62.1450	62.0600	61.9571	61.8382
50	62.3186	62.3267	62.3099	62.2670	62.2020	62.1170	62.0140	61.8950
60	62.3724	62.3805	62.3637	62.3208	62.2557	62.1706	62.0675	61.9484
70	62.4163	62.4245	62.4076	62.3647	62.2996	62.2144	62.1112	61.9920

Note: All values are in pounds per cubic foot, 1 lb/ft<sup>3</sup> = 16 kg/m<sup>3</sup>; 1 ft = 0.048 m.

Density of water from Source 1, p. 296

Gravity formula from Source 4, p. 488

$$G_0 = 980.616 (1 - 0.0026373 \cos 2\theta + 0.0000059 \cos^2 2\theta)$$

Altitude correction = 0.0003086 × altitude in meters.

Standard gravity = 980.665 cm/s<sup>2</sup>

Density of air from Source 2:

$$\text{Density} = 0.001225(1 - 0.0065H|288.16)^{4.2561}$$

where  $H$  is in meters

Sources:

1. *Smithsonian Physical Tables*, 9th rev. ed.
2. National Advisory Committee for Aeronautics, TN 3182.
3. American Society of Mechanical Engineers, PTC 2-1971.
4. *Smithsonian Meteorological Tables*, 6th rev. ed.

**NET POSITIVE SUCTION HEAD** The net positive suction head ( $NPSH$ )  $h_{sp}$  is the total suction head in feet (meters) of liquid absolute determined at the suction nozzle and referred to datum less the vapor pressure of the liquid in feet (meters) absolute.

**DRIVER INPUT** The driver input ehp is the input to the driver expressed in horsepower (kilowatts). Usually this is electric input horsepower (kilowatts).

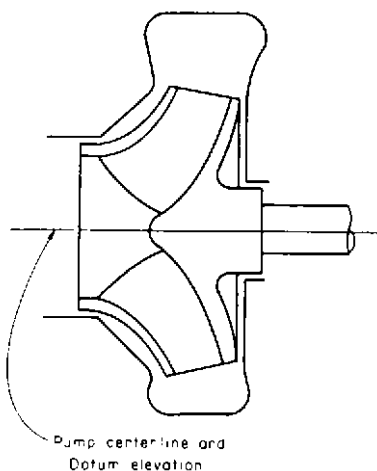


FIGURE 1 Horizontal pump

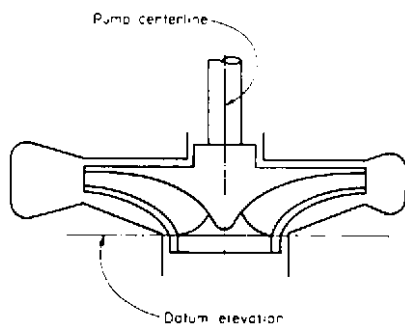


FIGURE 2 Vertical single-suction pump

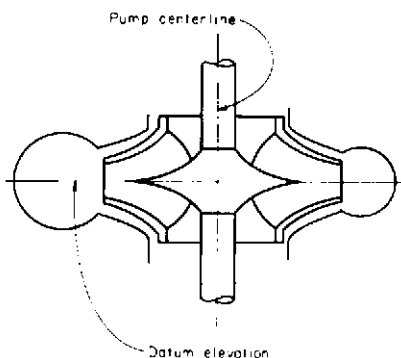


FIGURE 3 Vertical double-suction pump

**PUMP INPUT** Pump input bhp is the power delivered to the pump shaft and is designated as brake horsepower (brake kilowatts).

**LIQUID OR WATER POWER** Water power whp (wkW) is the useful work delivered by the pump and is usually expressed by the formula

in USCS units 
$$\text{whp} = \frac{(\text{sp. gr.})QH}{3960}$$

in SI units 
$$\text{wkW} = 9.8QH(\text{sp. gr.})$$

where sp. gr. = specific gravity of liquid, referred to water at 68°F (20°C)

$Q$  = flow rate, gpm( $\text{m}^3/\text{h}$ )

$H$  = total head, ft (m)

**TABLE 2** Variation of acceleration of gravity with latitude and altitude

Latitude	Altitude above mean sea level, ft						
	0	2000	4000	6000	8000	10,000	12,000
0°	32.0878	32.0816	32.0754	32.0693	32.0631	32.0569	32.0508
10	32.0929	32.0867	32.0805	32.0744	32.0682	32.0620	32.0558
20	32.1076	32.1014	32.0952	32.0890	32.0829	32.0767	32.0705
30	32.1301	32.1239	32.1177	32.1115	32.1054	32.0992	32.0930
40	32.1577	32.1515	32.1454	32.1392	32.1330	32.1269	32.1207
50	32.1872	32.1810	32.1748	32.1687	32.1625	32.1563	32.1501
60	32.2149	32.2087	32.2026	32.1964	32.1902	32.1841	32.1779
70	32.2375	32.2314	32.2252	32.2190	32.2129	32.2067	32.2005

Note: All values are in feet per second per second;  $1 \text{ ft/s}^2 = 0.3048 \text{ m/s}^2$ ;  $1 \text{ ft} = 0.3048 \text{ m}$

Gravity =  $980.616 (1 - 0.0026373 \cos 2\theta + 0.0000059 \cos^2 2\theta)(1.0/30.48)$

Correction for altitude =  $-0.003086 \text{ ft/s}^2/1,000 \text{ ft}$

The international standard value of gravity adopted by the International Commission on Weights and Measures is  $980.665 \text{ cm/s}^2$  ( $32.17405 \text{ ft/s}^2$ ) at sea level and approximately latitude  $45^\circ$ .

#### Sample Computation

Given:

Altitude = 12,000 ft (3657.60 m)

Latitude =  $70^\circ$

Water temperature =  $40^\circ\text{F}$  ( $4.4^\circ\text{C}$ )

Altitude correction for gravity:

$$0.0003086 \times 3657.60 = 1.128785 \text{ cm/s}^2$$

Gravity corrected for latitude and altitude:

$$\text{Gravity} = 980.616 (1 - 0.0026373 \cos 140^\circ - 0.0000059 \cos^2 140^\circ) - 1.128735 = 981.471784 \text{ cm/s}^2$$

Density corrected for gravity:

$$\text{Density} = (0.9999988 \times 981.471784/980.6650 \times 1.000028) = 1.0007930 \text{ g/cm}^3$$

Correcting for buoyancy of air:

$$\text{Density} = 1.0007930 - 0.0008491 = 0.9999438 \text{ g/cm}^3$$

Density in USCS units:

$$\text{Density} = 0.9999438 \times 62.4279606 = 62.4244543 \text{ lb/ft}^3$$

Sources:

1. "Smithsonian Physical Tables," 9th Rev. Ed.
2. American Society of Mechanical Engineers, PTC 2—1971

This formula is derived on p. 13.36.

**EFFICIENCY** Pump efficiency  $E_p$  is the ratio of the power delivered by the pump to the power supplied to the pump shaft; that is, the ratio of the liquid power (also known as water power) to the brake power expressed in percent:

$$\text{In USCS units} \quad E_p = \frac{\text{whp}}{\text{bhp}} \times 100$$

$$\text{In SI units} \quad E_p = \frac{\text{wkW}}{\text{kW}} \times 100$$

Overall efficiency  $E_o$  is the ratio of the power delivered by the pump to the power supplied to the input side of the pump driver; that is, the ratio of the output power to the input power to the driver.

$$\text{In USCS units} \quad E_o = \frac{\text{whp}}{\text{ehp}} \times 100$$

$$\text{In SI units} \quad E_o = \frac{\text{wkW}}{\text{kW}} \times 100$$

**PRIME MOVER RATINGS** The prime movers for driving pumps are rated according to established standards. For example, for electric motor drivers, see the standards of the latest edition of the *National Electrical Manufacturers Association*.

## ACCURACY AND TOLERANCES

---

**Accuracy** The accuracy to which tests can be made depends on the instruments used, their proper installation, the skill of the test engineer, and the shop tests for the simulation of field conditions. The test engineer must have sufficient knowledge of the characteristics and limitations of the test instruments to obtain maximum accuracy when using them, along with a thorough understanding of the pumps, prime movers, controls, and installation peculiarities to interpret the results. For shop testing, the acceptable deviations and fluctuations of the instrumented test readings are given in Table 1.11 of the *ASME Performance Test Code for Centrifugal Pumps* (ASME PTC 8.2-1990). These deviations are not to be misconstrued as tolerances, which must be spelled out in the specifications. The limits of accuracy of pump test measuring devices for use in field testing are shown in Figure 4. Using these limits, the combined accuracy of the efficiency is the square root of the quantity [square of the head accuracy plus square of the flow rate accuracy plus square of the power input accuracy]:

$$A_e = \sqrt{(\pm H^2) + (\pm Q^2) + (\pm \text{ehp}^2)} \quad (\text{percent})$$

Pump speed and voltage are not required for efficiency computations, and so the values for these are not included in this formula.

**Instrumentation** All instruments should be calibrated before the tests, and all calibration and correction data or curves should be prepared in advance. Where required, a certified calibration curve showing the calibration of the instrument, including any procedures for establishing a coefficient, should be furnished before testing begins. The specifications should be explicit in regard to a waiving of these calibration requirements. After testing, all instruments should be recalibrated. Any differences between before and after calibration values must be resolved either by retest or by acceptable variations being spelled out in the specifications.

**Tolerances** The tolerances in pump performance permitted are usually given in the specifications. The user can and should make these requirements known before the order for pumping apparatus is placed. The test tolerances permitted by the Hydraulic Institute are quite commonly used: They state that no minus tolerance or margin shall be allowed on capacity, total head, or efficiency at the rated condition. Also, a plus tolerance of not more than 10% of rated capacity shall be allowed at the rated head and speed.

The tolerances are quite easy to meet; they protect the user from getting pumps that are too small to do the job and also from getting oversized pumps and drivers that would increase building, installation, and operating costs. These tolerances also give the manufacturer liberal leeway when impeller trim is required to meet the specified conditions.

## TEST REQUISITES

---

**Operating Conditions** The primary factors affecting the operation of a pump are the inlet (suction), outlet (discharge or total head), and speed. The secondary factors are phys-



Quantity to be measured	Measuring device	Calibrated limit of accuracy plus or minus, %
Capacity	Venturi meter	$\frac{1}{4}$
	Nozzle	1
	Pitot tube	$1\frac{1}{2}$
	Orifice	$1\frac{1}{4}$
	Disk	2
	Piston	$\frac{1}{4}$
	Volume or weight—tank	1
	Propeller meter	4
Head	Electric sounding line	$\frac{1}{4}$
	Air line	$\frac{1}{2}$
	Liquid manometer, 3- to 5-in (75- to 127-mm) deflections	$\frac{1}{4}$
	Liquid manometer, over 5-in (127-mm) deflections	$\frac{1}{2}$
	Bourdon gage—5 in (127-mm) min dial:	
	$\frac{1}{4}$ – $\frac{1}{2}$ full scale	1
	$\frac{1}{2}$ – $\frac{3}{4}$ full scale	$\frac{1}{4}$
Over $\frac{3}{4}$ scale	$\frac{1}{2}$	
Power input	Watt-hour meter and stopwatch	$1\frac{1}{2}$
	Portable recording wattmeter	$1\frac{1}{2}$
	Test precision wattmeter:	
	$\frac{1}{4}$ – $\frac{1}{2}$ scale	$\frac{1}{4}$
	$\frac{1}{2}$ – $\frac{3}{4}$ scale	$\frac{1}{2}$
	Over $\frac{3}{4}$ scale	$\frac{1}{4}$
	Clamp on ammeter	4
Speed	Revolution counter and stopwatch	$1\frac{1}{4}$
	Handheld tachometer	$1\frac{1}{4}$
	Stroboscope	$1\frac{1}{2}$
	Automatic counter and stopwatch	$\frac{1}{2}$
Voltage	Test meter:	
	$\frac{1}{4}$ – $\frac{1}{2}$	1
	$\frac{1}{2}$ – $\frac{3}{4}$	$\frac{1}{4}$
	$\frac{3}{4}$ –full	$\frac{1}{2}$
	Rectifier voltmeter	5

Source: ANSI B-58.1 (AWWAE 101-61).

FIGURE 4 Limits of accuracy of pump test measuring devices in field use

ical and climatic variables, such as the temperature, viscosity, specific weight, and turbidity of the liquid being pumped and the elevation of the pumping system above sea level. In some installations, it is impossible to measure discharge or even head accurately. In these instances, good shop tests are essential. It follows then that, in order for the shop test to predict the field performance of a pump, the field operating, installation, and suction conditions should be simulated.

The inlet passages are critical, and the sump where used on the suction lift must be duplicated as closely as possible. During the shop tests, no total suction head less than specified should be permitted, nor should the suction head exceed the specified amount in cases where cavitation or possibly operating "in the break" could occur.

For field installations above sea level, the difference in elevation between the shop test site and the field installation must be taken into account by reducing to the barometric pressure at the specified elevation. This is especially true if a suction lift or negative suction head is involved. Standard tables of barometric pressures are available for use in computing the data, and the tables to be used should be acceptable to all interested parties.

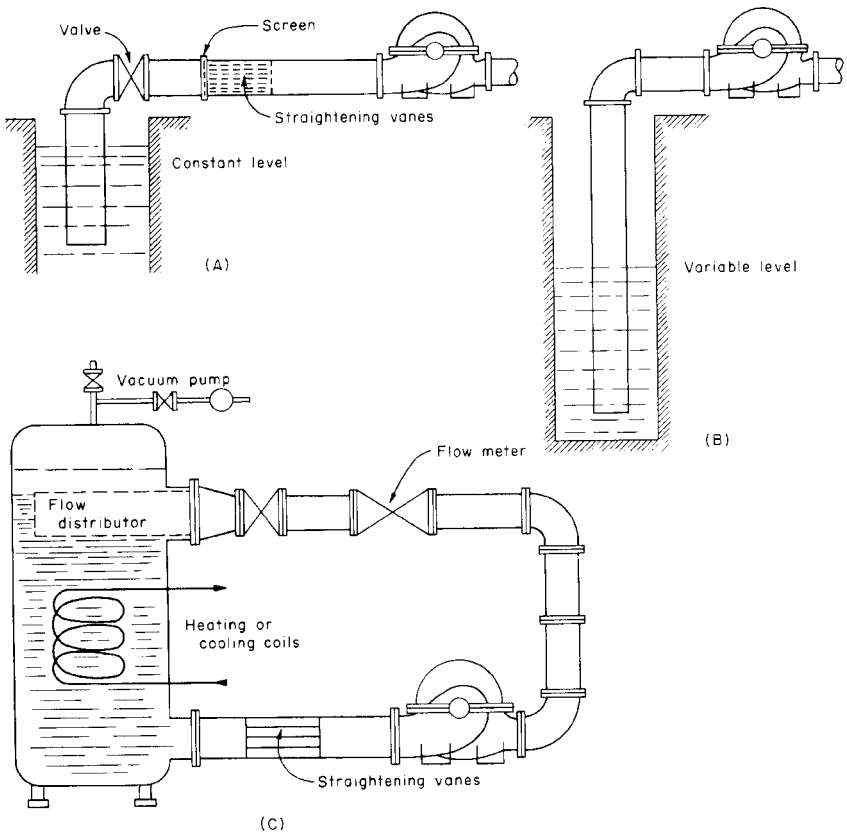


FIGURE 5A through C Typical arrangement for determining cavitation characteristics (Hydraulic Institute Standards, 13th Edition—out of print<sup>2</sup>)

**Cavitation Tests** Cavitation tests should be run if required by the specifications (provided such tests are needed and have not been previously conducted on similar pumps and certified by the manufacturer) or if needed to assume a successful pump installation.

The suction requirements that must be met by the pump are usually defined by the cavitation coefficient  $\sigma$ . Plant  $\sigma$  is defined as  $NPSHA$  (net positive suction head available) divided by total pump head per stage:

$$\sigma = \frac{NPSHA}{H}$$

Three typical arrangements for determining the cavitation characteristics of pumps are illustrated in Figure 5. In Figure 5A, the suction is taken from a sump with a constant-level surface. The liquid is drawn first through a valve (throttle) and then through a section of pipe containing screens and straightening devices, such as vanes and baffles. This setup will dissipate the turbulence created by the suction valve and will also straighten the flow so the pump suction flow will be relatively free from undue turbulence. In Figure 5B, the suction is taken from a relatively deep sump or well in which the water surface can be varied over a fairly large range to provide the designed variation in suction lift. In Figure 5C, the suction is taken from a closed vessel in a closed loop in which the pressure level

## PUMP TESTING

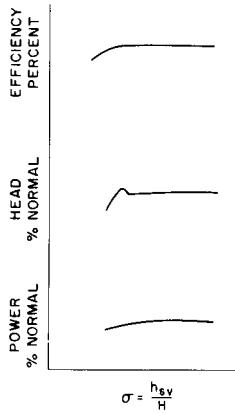


FIGURE 6 Functions of sigma at constant capacity and speed; suction pressure varied

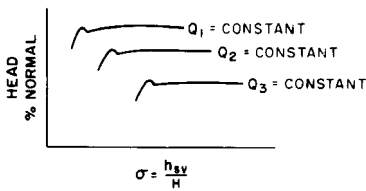


FIGURE 7 Sigma capacities above and below normal; suction pressure varied

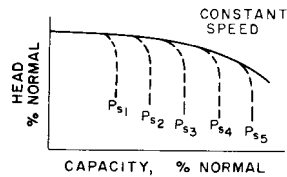


FIGURE 8 Typical cavitation curves at constant speed and suction pressure

can be varied by a gas pressure over the liquid, by temperature of the liquid, or by a combination of these.

By using one of these cavitation test arrangements, the critical value of  $\sigma$  (that is, the value at which cavitation will begin) can be found by one of the following two methods:

1. Constant speed and capacity vary the suction lift. Run the pump at constant speed and capacity with the suction lift varied to produce cavitation conditions. Plots of the head, efficiency, and power input against  $\sigma$  as shown in Figure 6.

When the values of  $\sigma$  are held high, the values of head, efficiency, and power should remain relatively constant. As  $\sigma$  is reduced, a point is reached when the curves break from the normal, indicating an unstable condition. This breakaway condition may and usually does impair the operation of the pump. The extent of impairment depends on the size, specific speed, and service of the pump and on the characteristics of the pumped fluid. A variation of this method is to plot results using capacities both greater and less than normal, as shown in Figure 7.

2. Constant speed and suction lift vary the capacity. Run the pump at constant speed and suction lift and vary the capacity. For a given suction lift, the pumping head is plotted against capacity. A series of such tests will result in a family of curves, as shown in Figure 8.

Where the plotted curve for any suction condition breaks away from the normal, cavitation has occurred. The value of  $\sigma$  may be calculated at the breakaway points by dividing  $NPSHA$  by total head  $H$  at the point under consideration.

## TEST PROCEDURE

---

**Agreements** The specifications and contract should be very clear on any special points that must be covered by the pump testing. All interested parties shall be represented and given equal rights in regard to test date, setup, conditions, instrumentation, calibration of instruments, examination of pump and test setup, and accuracy of results and computations. Any controversial points or methods not provided for in the specifications should be resolved to the satisfaction of all interested parties before testing is begun.

In some special instances and by agreement between parties, an independent test expert may be engaged to take over full responsibility of the test stand and apparatus. This person will make all decisions after consultation with the interested parties and should be used only where an impasse is reached.

Normally, the manufacturer will establish the time and date for the pump tests. In some cases, the specifications will cover such items as duration, limiting date, and notification time. Reasonable notice must be given to all official witnesses or representatives. A 30-day notice is preferred, and one week should be considered a bare minimum.

Any time limitation regarding correction of mechanical defects or equipment malfunctions that arise during testing must be resolved by mutual agreement.

**Observers and Witnesses** Representatives from each party to the contract shall have equal opportunity to attend the testing. Where more than one representative from one of the parties is present, their function as observers, official witnesses, or representatives must be made clear before the start of testing. The number of representatives present from any one party shall not be a deciding factor when disagreements are being resolved. Any comments or constructive criticism from the observers and witnesses should be duly considered.

**Inspection and Preliminary Operation** All interested parties shall make as complete an inspection as possible before, during, and after the test to determine compliance with specifications and correct connection of all instrumentation. The following items should be inspected before or during the test:

- Impeller and casing passages
- Pump and driver alignment
- Piezometer openings
- Electrical connections
- Lubricating devices and system
- Wearing ring and other clearances
- Stuffing box or mechanical seal adjustment and leakage

This is not a complete list of items and should be taken as only a guide for the interested parties. Instruments installed on the pump to obtain the necessary test information shall not affect the pump operation or performance. If a question arises as to the effect an instrument has on the operation, it should be resolved by all parties. Where necessary, comparative preliminary tests can be conducted with the disputed equipment removed and then reinstalled. The dimensions at the piezometer connections on both the suction and discharge sides must be accurately determined to permit accurate determination of the velocity head correction.

On satisfactory completion of the preliminary inspection, the pump may be started. The pump and all instrumentation should then be checked for proper operation, scale readings, or evidence of malfunction. When all equipment and apparatus are functioning properly, a preliminary test run should be made. If possible, this run should be made at or near the rated condition. The correct procedures for observing and recording the data should be established during this run. Also, the time it takes to obtain steady test conditions is determined for use in the pump test runs. The acceptable deviations and fluctuations for test readings are given in the section named "Accuracy."

### **Suggested Test Procedure**

**TIME AND DATE** After tests have been decided upon, it is to the best interests of all parties to conduct them with the least delay. The contract normally will not give a time or date for the test, but will specify a completion date for submission or approval of a final test report.

**PERSONNEL** Pump testing, regardless of classification, should be carried out by personnel specially trained in the operation of the test equipment used. Representatives from each party to the contract shall be given equal opportunity to witness the test or tests and shall also have equal voice in commenting on the conduct of the tests or on compliance with specifications or code requirements where applicable.

**SCHEDULE** A schedule should be agreed upon by all parties in advance of the test. The schedule should be as complete a program as possible and give some particulars on the range of test heads, discharge rates, and speed to be used. This schedule should be flexible and subject to change, especially after the preliminary runs have been made.

**INSPECTION** The pump and test setup should be thoroughly inspected both before and after the tests. Special attention should be given to the hydraulic passages and pressure taps near the suction and discharge sections. Also, the discharge measuring device should be inspected.

**CALIBRATION OF INSTRUMENTS** While the setup is being inspected, all measuring devices should be calibrated and adjusted as explained under the section named "Instrumentation."

**PRELIMINARY TESTS** After it has been determined that the test setup complies with the installation and specification requirements and that the instrumentation is properly installed, the pump is started. A sufficient number of preliminary test runs should be made to check the functioning of the test stand and all control and measuring devices. These preliminary tests also give the test personnel and representatives an opportunity to check and adjust the entire setup and serve as a basis for agreements on accuracy and compliance. Each test point is held until satisfactory stable conditions exist. The acceptable fluctuations in test readings is covered under "Accuracy." It is suggested that preliminary computations be made, plotted, and analyzed prior to actual test runs. (*Note:* Most pump manufacturers will conduct a complete preliminary shop test to be sure of specifications and contractual compliance before inviting the purchaser's representatives to witness the official test.)

**OFFICIAL TEST RUNS** The test points for the official test runs must be sufficient in number to establish the head-discharge curve over the specified range and to provide any other data needed to compute or plot the information required by the specifications. It is suggested that one test run be as near the rated condition as possible and that at least three runs be in the specified operating range of the pump.

**LOGGING OF EVENTS** In most instances, the official pump test is conducted by only two, three, or four test engineers, and no record other than test data is needed. In more complicated or important tests, it is sometimes very desirable to assign someone the task of recording and logging events as they occur. This is most important if reruns are required. Complete records, including any notes or comments on inspection and calibration, shall be kept of all data, readings, observations, and information relevant to the test. A suggested form for shop and field tests is shown in Figure 28.

**PRELIMINARY COMPUTATIONS** Sufficient preliminary computations should be made to determine whether all specification requirements have been met and whether reruns will be necessary.

**RERUNS** When the preliminary computations indicate that reruns are necessary, they should be run immediately or as soon as possible after the official test runs and with the same personnel, instruments, and devices. Sometimes mechanical or electrical faults will necessitate a rerun. If after correction of these faults several reruns indicate a change, a complete retesting may be required. Any official representatives shall have the right to ask for a rerun or be shown to their satisfaction that a rerun is not required.

**COMPUTATIONS, PLOTTING REPORTS** These topics are discussed later in the text.

## TEST MEASUREMENTS

---

**DISCHARGE** The choice of which method of discharge measurement to use should be made by agreement between all parties concerned. Some test codes and procedures in regular use permit or even recommend certain methods for model or shop testing, but restrict their use in field or index testing. Some methods are more adaptable to the site conditions than others, and so the test engineers and interested parties should be completely familiar with the several methods applicable before settling on the one to be used.

The most commonly used methods of discharge measurement are those that use quantity meters and those that use rate-of-flow meters. Both meters are usually classified as liquid meters, and their functions are listed in Table 3.

**QUANTITY METERS** The term *quantity* is here used to designate those meters in which the fluid passes through the primary element in successive and more or less completely isolated quantities, either weights or volumes, by alternately filling and emptying containers of known capacities. The secondary element of a quantity meter consists of a counter with suitably graduated dials for registering the total quantity that has passed through. Quantity meters are classified into two groups: weighing meters and volumetric meters.

**WEIGHING METERS** There are two types of weighing meters: weighing tank and tilting trap. In the tilting trap meter, the equilibrium of a container is upset by a rise of the center of gravity as the container is filled. Weighing tank meters employ a container suspended from a counterbalanced scale beam. The weighing tank and the tilting trap are affected slightly by the temperature of the liquid but not enough to cause concern in normal testing.

**VOLUMETRIC METERS** Volumetric meters measure volumes instead of weights. There are four types: tank, reciprocating piston, rotary piston, and nutating disk.

Tank meters are a very elementary form of meter of limited commercial importance. As the name implies, they consist of one or more tanks that are alternately filled and emptied. The height to which they are filled can be regulated manually or automatically. In some cases, the rising liquid operates a float that controls the inflow and outflow; in others, it

**TABLE 3** Liquid meters and their functions

Quantity meters	Rate-of-flow meters
Weighing meters	Differential pressure meters
Weighing tank	Venturi
Tilting trap	Nozzle
Volumetric meters	Orifice plate
Tank	Pitot tube
Reciprocating piston	Head area meters
Rotary piston	Weir
Nutating disk	Flume
	Current meters

starts a siphon. Occasionally, some tank meters have been erroneously classified as weighing meters.

Reciprocating piston meters use one or more members that have a reciprocating motion and operate in one or more fixed chambers. The quantity per cycle can be adjusted either by varying the magnitude of movement of one or more of the reciprocating members or by varying the relation between the primary and secondary elements.

Rotary (or oscillating) piston meters have one or more vanes that serve as pistons or movable partitions for separating the fluid segments. These vanes may be either flat or cylindrical and rotate within a cylindrical metering chamber. The axis of rotation of the vanes may or may not coincide with that of the chamber. The portion of the chamber in which the fluid is measured usually includes about  $270^\circ$ . In the remaining  $90^\circ$ , the vanes are returned to the starting position for closing off another segment of fluid. This may be accomplished by the use of an idle rotor or gear, a cam, or a radial partition. The vanes must make almost a wiping contact with the walls of the measuring chamber. The rotation of the vanes operates the counter.

Nutating disk meters have the disk mounted in a circular chamber with a conical roof and either a flat or conical floor. When in operation, the motion of the disk is such that the shaft on which it is mounted generates a cone with the apex down. However, the disk does not rotate about its own axis; this is prevented by a radial slot that fits about a radial partition extending in from the chamber sidewall nearly to the center. The peculiar motion of the disk is called *nutating*. The inlet and outlet openings are in the sidewall of the chamber on either side of the partition. These meters are usually adjusted by changing the relation between the primary and secondary elements.

**RATE-OF-FLOW METERS** The term *rate of flow* is applied to all meters through which the fluid passes not in isolated quantities but in a continuous stream. The movement of this fluid stream through the primary element is directly or indirectly utilized to actuate the secondary element. The quantity of flow per unit time is derived from the interactions of the stream and the primary element, using physical laws supplemented by empirical relations.

In rate-of-flow meters, the functioning of the primary element depends upon some property of the fluid other than, or in addition to, volume or mass. This property may be kinetic energy (head meters), inertia (gate meters), specific heat (thermal meters), or the like. The secondary element senses a change in the property concerned and usually embodies some device that draws the necessary inferences automatically, so the observer can read the rate of flow from a dial or chart. In some cases, the secondary element records pressures, such as static and differential, from which the rate of flow and time-quantity flow must be computed. In others, the secondary element not only indicates the rate of flow but also integrates it with respect to time and records the total quantity that has passed through the meter. In some cases, the indications of the secondary element are transmitted to a point some distance from the primary element.

**DIFFERENTIAL PRESSURE METERS** With this group of meters the stream of fluid creates a pressure difference as it flows through the primary element. The magnitude of this pressure difference depends upon the speed and density of the fluid and features of the primary element.<sup>3</sup>

Flow in a pipeline, or closed pressure conduit, can be measured by a wide variety of methods, and the choice of method for a particular installation will depend upon prevailing conditions. The accuracy of flow measurements in pressure conduits made with properly selected, installed, and maintained measuring equipment, such as venturi meters, flow nozzles, orifice meters, and pitot tubes, can be very high.

The venturi meter (Figure 9) is perhaps the most accurate flow measuring device that can be used in a water supply system. It contains no moving parts, requires very little maintenance, and causes very little head loss. Venturi meters operate on the principle that flow in a closed conduit system is faster through areas of small cross section ( $D_2$  in Figure 9) than through areas of large cross action ( $D_1$ ). The total energy in the flow, consisting primarily of velocity head and pressure head, is essentially the same at  $D_1$  and  $D_2$ . Thus the pressure must decrease in the constricted throat  $D_2$ , where the velocity is higher, and conversely must increase at  $D_1$  upstream from the throat, where the velocity is lower. This

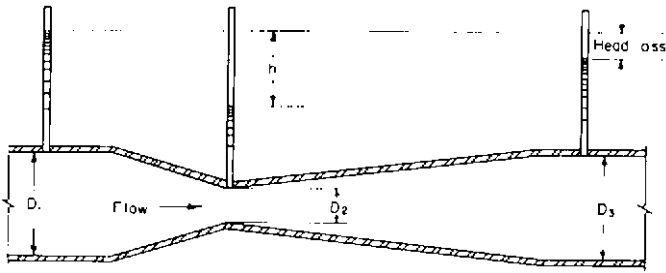


FIGURE 9 Diagram of venturi meter

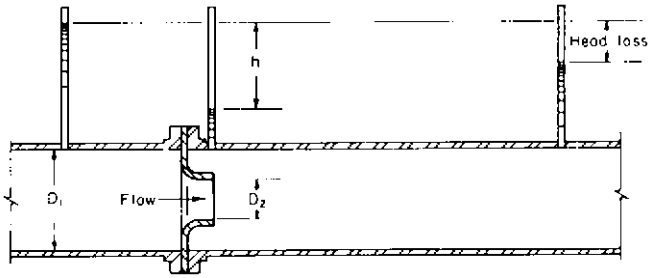


FIGURE 10 Diagram of flow nozzle

reduction in pressure from the meter entrance to the meter throat is directly related to the rate of flow through the meter and is the measurement used to determine flow rate.

The coefficient of discharge for the venturi meter ranges from 0.935 for small-throat velocities and diameters to 0.988 for large-throat velocities and diameters. Equations for the venturi meter are

$$Q = \frac{CA_2\sqrt{2gh}}{\sqrt{1-R^4}}$$

$$Q' = 3.118 \frac{CA'_2\sqrt{2gh}}{\sqrt{1-R^4}}$$

where  $Q$  = rate of flow, ft<sup>3</sup>/s (m<sup>3</sup>/s)

$C$  = coefficient of discharge for meter

$A_2$  = area of throat section, ft<sup>2</sup> (m<sup>2</sup>)

$g$  = acceleration of gravity, 32.17 ft/s<sup>2</sup> (9.81 m/s<sup>2</sup>)

$h$  = differential head of liquid between meter inlet and throat, ft (m)

$R$  = ratio of throat to inlet diameter ( $D_2/D_1$ )

$Q'$  = rate of flow, gpm

$A'_2$  = area of throat section, in<sup>2</sup>

Flow nozzles operate on the same basic principle as venturi meters. In effect, the flow nozzle is a venturi meter that has been simplified and shortened by omission of the long diffuser on the outlet side (Figure 10). The streamlined entrance of the nozzle provides a



straight cylindrical jet without contraction, so the coefficient of discharge is almost the same as that for the venturi meter. In the flow nozzle, the jet is allowed to expand of its own accord, and the high degree of turbulence created downstream from the nozzle causes a greater loss of head than occurs in the venturi meter, where the diffuser suppresses turbulence. The relationship of flow rate to head and flow nozzle dimensions is

$$Q = \frac{CA_2\sqrt{2gh}}{\sqrt{1-R^4}}$$

$$Q' = \frac{3.118CA_2'\sqrt{2gh}}{\sqrt{1-R^4}}$$

where  $Q$  = rate of flow, ft<sup>3</sup>/s (m<sup>3</sup>/s)

$C$  = coefficient of discharge for nozzle

$A_2$  = area of nozzle throat, ft<sup>2</sup> (m<sup>2</sup>)

$g$  = acceleration of gravity, 32.17 ft/s<sup>2</sup> (9.81 m/s<sup>2</sup>)

$h$  = head at or across the nozzle, ft (m)

$R$  = ratio of throat to inlet diameter ( $D_2/D_1$ )

$Q'$  = rate of flow, gpm

$A_2'$  = area of nozzle throat, in<sup>2</sup>

In an orifice meter, a thin plate orifice inserted across a pipeline is used for measuring flow in much the same manner as a flow nozzle (Figure 11). The upstream pressure connection is often located about one pipe diameter upstream from the orifice plate. The pressure of the jet ranges from a minimum at the *vena contracta* (the smallest cross section of the jet) to a maximum at about four or five conduit diameters downstream from the orifice plate. The downstream pressure connection (the center connection in Figure 11) is usually made at the *vena contracta* to obtain a large pressure differential across the orifice.

The pressure tap openings should be free from burrs and flush with the interior surfaces of the pipe. Equations for the orifice plate are

$$Q = \frac{CA_2\sqrt{2gh}}{\sqrt{1-R^4}}$$

$$Q' = \frac{3.118CA_2'\sqrt{2gh}}{\sqrt{1-R^4}}$$

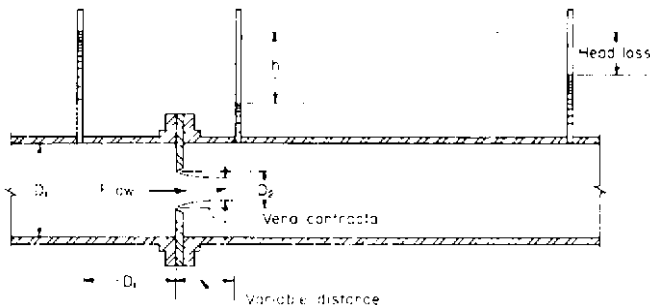


FIGURE 11 Diagram of orifice meter

- where  $Q$  = rate of flow, ft<sup>3</sup>/s (m<sup>3</sup>/s)  
 $C$  = coefficient of discharge for orifice plate  
 $A_2$  = area of orifice, ft<sup>2</sup> (m<sup>2</sup>)  
 $g$  = acceleration of gravity, 32.17 ft/s<sup>2</sup> (9.81 m/s<sup>2</sup>)  
 $h$  = head across the orifice plate, ft (m)  
 $R$  = ratio of throat to inlet diameter ( $D_2/D_1$ )  
 $Q'$  = rate of flow, gpm  
 $A'_2$  = area of orifice, in<sup>2</sup>

The principal disadvantage of orifice meters, compared with venturi meters and flow nozzles, is their greater loss of head. On the other hand, they are inexpensive and capable of producing accurate flow measurements.

It should be noted that the relationship of flow rate to head and dimensions of the metering section is identical for the venturi meter, flow nozzle, and orifice meter except that the coefficients of discharge vary.

Where it is impossible to employ one of the methods previously described, the pitot tube is often used. A pitot tube in its simplest form consists of a tube with a right-angle bend which, when partly immersed with the bent part under water and pointed directly into the flow, indicates flow velocity by the distance water rises in the vertical stem. The pitot tube makes use of the difference between the static and total pressures at a single point.

The height of rise  $h$  of the water column above the water surface, expressed in feet (meters) and tenths of feet (millimeters), equals the velocity head  $v^2/2g$ . The velocity of flow  $v$  in feet (meters) per second may thus be determined from the relation  $v = \sqrt{2gh}$ .

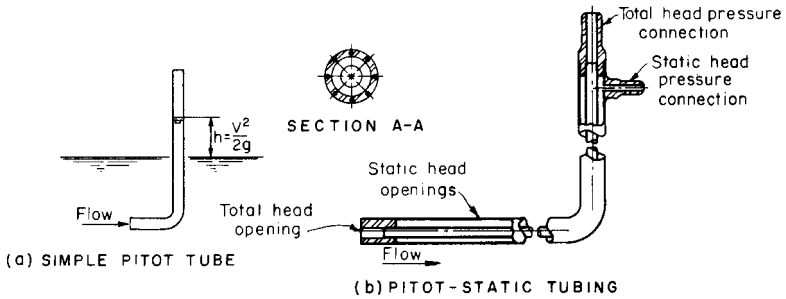
In a more complete form known as the pitot static tube, the instrument consists of two separate, essentially parallel parts, one for indicating the sum of the pressure and velocity heads (total head) and the other for indicating only the pressure head. Manometers are commonly used to measure these heads, and the velocity head is obtained by subtracting the static head from the total head. A pressure transducer may be used instead of the manometer to measure the differential head. Oscillographic or digital recording of the electric signal from the transducer provides a continuous record of the changes in head.

The simple form of the pitot tube has little practical value for measuring discharges in open channels handling low-velocity flows because the distance the water in the manometer tube rises is difficult to measure. This limitation is overcome to a large extent by using a pressure transducer for the measurement and precise electronic equipment for the data readings.

The pitot static tube, on the other hand, works very well for this purpose if the tube is used with a differential manometer of the suction lift type (Figure 12). In this manometer, the two legs are joined at the top by a T that connects to a third line, in which a partial vacuum can be created. After the pitot tube has been bled to remove all air, water flows up through it into the manometer to the height desired for easy reading. Then the stopcock or clamp on the vacuum line is closed. The partial vacuum acts equally on the two legs and does not change the differential head. The velocity head  $h$  is then the difference between the total head reading and the static head reading. If desired, a pressure transducer can also be used for the head measurement.

Pitot tubes can be used to measure relatively high velocities in canals, and it is often possible to make satisfactory discharge measurements at drops, chutes, overfall crests, or other stations where the water flows rapidly and fairly large velocity heads occur. At low velocities, values of  $h$  become quite small. The pitot tube head error for a low velocity will lead to a much larger inaccuracy in discharge computation than the same error when the velocity is high. The velocity traverse with a pitot tube may be made in the same manner as with a current meter (discussed later).

**HEAD AREA METERS** The instruments used to measure flow in open conduits are normally classified as head area meters, the most common of which are weirs and flumes.



(c) SUCTION-LIFT MANOMETER

FIGURE 12A through C Pilot tubes and manometer.

A weir is an overflow structure built across an open channel. Weirs are one of the oldest, simplest, and most reliable structures for measuring the flow of water in canals and ditches. These structures can be easily inspected, and any improper operations can be quickly detected and corrected.

The discharge rates are determined by measuring the vertical distance from the crest of the overflow portion of the weir to the water surface in the pool upstream from the crest and referring to computation tables that apply to the size and shape of the weir. For standard tables to apply, the weir must have a regular shape and definite dimensions and must be placed in a bulkhead and pool of adequate size so the system performs in a standard manner.

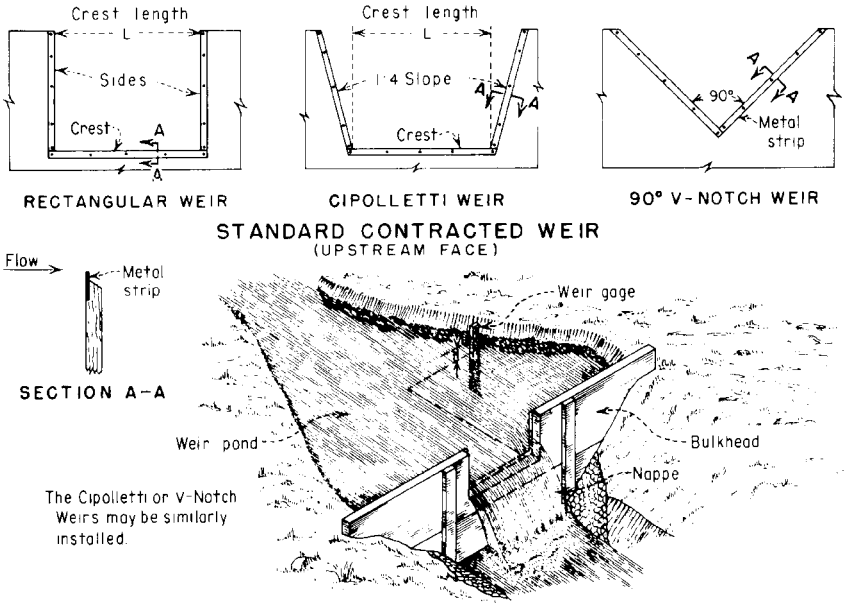
Weirs may be termed rectangular, trapezoidal, or triangular, depending upon the shape of the opening. In rectangular and trapezoidal weirs, the bottom edge of the opening is the crest and the side edges are called *sides* or *weir ends* (Figures 13 and 14). The sheet of water leaving the weir crest is called the *nappe*. In certain submerged conditions, the under-nappe airspace must be ventilated to maintain near-atmospheric pressure.

The types of weirs most commonly used to measure water are

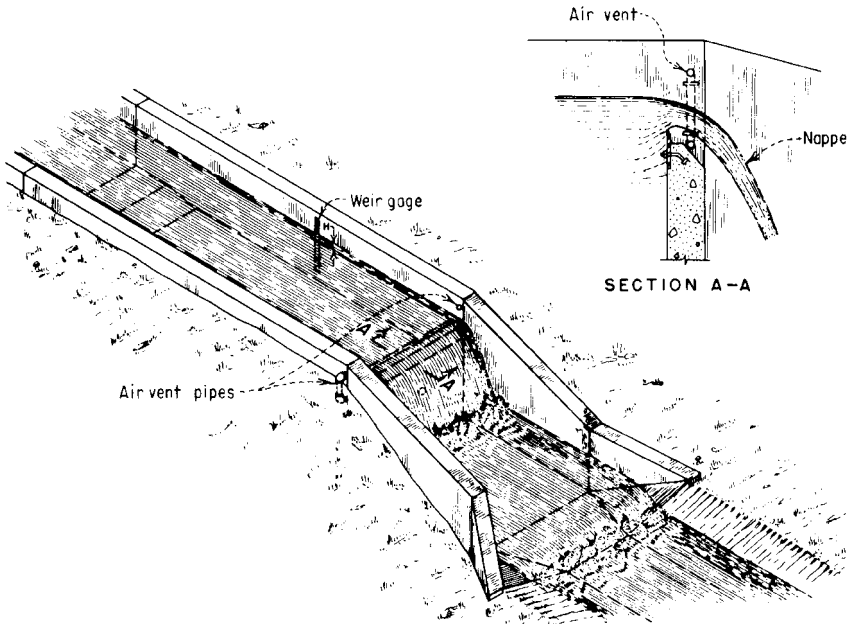
- Sharp-crested and sharp-sided Cipolletti weirs
- Sharp-sided 90° V-notch weirs
- Sharp-crested contracted rectangular weirs
- Sharp-crested suppressed rectangular weirs

For measuring water flow, the type of weir used has characteristics that make it suitable for a particular operating condition. In general, for best accuracy, a rectangular suppressed weir or a 90° V-notch weir should be used.

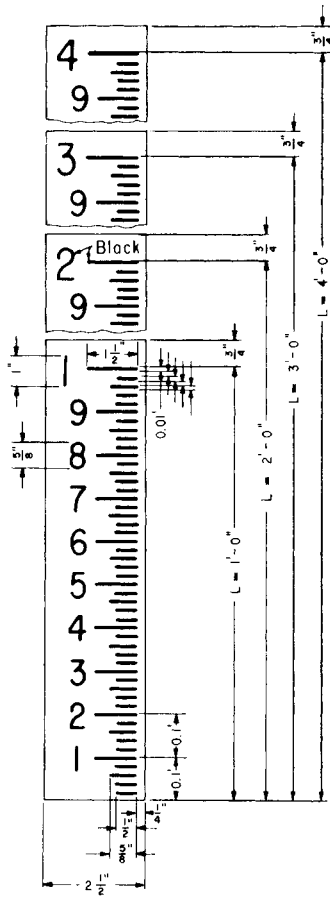
The discharge in second-feet (cubic meters per second) over the crest of a contracted rectangular weir, a suppressed rectangular weir, or a Cipolletti weir is determined by the



**FIGURE 13** Standard contracted weirs and temporary bulkhead with contracted rectangular weir discharging at free flow



**FIGURE 14** Typical suppressed weir in a flume drop



## NOTES

Material of 18 gage (U.S. Standard) metal coated with substantial thickness of porcelain enamel. Face of gage is white. Numerals and graduations are black. Graduations are sharp and accurate to dimensions shown. Length "L" represents gate limits. Gages may be made in any length desired using similar details.

FIGURE 15 Standard weir, or staff, gage

head  $H$  in feet (meters) and the crest length  $L$  in feet (meters). The discharge of the standard 90° V-notch weir is determined directly by the head on the bottom of the V notch.

As the stream passes over the weir, the top surface curves downward. This curved surface, or drawdown, extends upstream a short distance from the weir notch. The head  $H$  must be measured at a point on the water surface in the weir pond beyond the effect of the drawdown. This distance should be at least four times the maximum head on the weir, and the same gage point should be used for lesser discharges. A staff gage (Figure 15) having a graduated scale with the zero placed at the same elevation as the weir crest is usually provided for the head measurements.

Two widely used sets of formulas for computing discharge over standard contracted rectangular weirs are those of Smith<sup>4</sup> and Francis.<sup>5</sup> The formulas proposed by Smith require the use of coefficients of discharge that vary with the head of water on the weir and with the length of the weir. Consequently, the Smith formulas are somewhat inconvenient to use, although they are accurate for the ranges of coefficients usually given. For this type of weir operating under favorable conditions as prescribed in preceding paragraphs, the Francis formula when velocity of approach is neglected is

$$\text{in USCS units} \quad Q = 3.33H^{3/2}(L - 0.2H) \quad (1)$$

$$\text{in SI units} \quad Q = 1.837H^{3/2}(L - 0.2H)$$

and the formula when velocity of approach is included is

$$\text{in USCS units} \quad Q' = 3.33[(H + h)^{3/2} - h^{3/2}](L - 0.2H)$$

$$\text{in SI units} \quad Q' = 1.837[(H + h)^{3/2} - h^{3/2}](L - 0.2H) \quad (2)$$

where  $Q$  = discharge neglecting velocity of approach, ft<sup>3</sup>/s (m<sup>3</sup>/s)

$Q'$  = discharge considering velocity of approach, ft<sup>3</sup>/s (m<sup>3</sup>/s)

$H$  = head on weir, ft (m)

$L$  = length of weir, ft (m)

$h$  = head due to velocity of approach ( $v^2/2g$ ), ft (m)

Note that the Francis formulas contain constant discharge coefficients that allow computation without the use of tables. A table of  $\frac{3}{2}$  powers that provides values of  $H^{3/2}$ ,  $h^{3/2}$ , and  $(H + h)^{3/2}$  for convenience in computing discharge with the Francis formulas may be found in hydraulic handbooks.

The principal formulas used for computing the discharge of the standard suppressed rectangular weir were also proposed by Smith and Francis. In the Smith formulas for suppressed weirs, as for contracted weirs, coefficients of discharge vary with weir head and length; therefore, these formulas are not convenient for use in computations without tables or coefficients.

The Francis formula for the standard suppressed rectangular weir neglecting velocity of approach in

$$\text{in USCS units} \quad Q = 3.33LH^{3/2}$$

$$\text{in SI units} \quad Q = 1.857LH^{3/2} \quad (3)$$

and that including velocity of approach is

$$\text{in USCS units} \quad Q' = 3.33L[(H + h)^{3/2} - h^{3/2}]$$

$$\text{in SI units} \quad Q' = 1.837L[(H + h)^{3/2} - h^{3/2}] \quad (4)$$

In these formulas, the letters have the same significance as in the formulas for contracted rectangular weirs. The coefficient of discharge was obtained by Francis from the same general set of experiments as those used for the contracted rectangular weir. No tests have been made to determine the applicability of these formulas to weirs less than 4 ft (1.2 m) in length.

The Cipolletti weir is a contracted weir and must be installed as such to obtain reasonably correct and consistent discharge measurements. However, Cipolletti has compensated for the reduction in discharge due to end contractions by sloping the sides of the weir sufficiently to overcome the effect of contraction. The Cipolletti formula, in which the Francis coefficient is increased by about 1% and velocity of approach is neglected, is

$$\text{in USCS units} \quad Q = 3.367LH^{3/2} \quad (5)$$

$$\text{in SI units} \quad Q = 1.858LH^{3/2}$$

The formula including velocity of approach is

$$\text{in USCS units} \quad Q' = 3.367L(H + 1.5h)^{3/2} \quad (6)$$

$$\text{in SI units} \quad Q' = 1.858L(H + 1.5h)^{3/2}$$

where  $Q$  = discharge neglecting velocity of approach, ft<sup>3</sup>/s (m<sup>3</sup>/s)

$Q'$  = discharge considering velocity of approach, ft<sup>3</sup>/s (m<sup>3</sup>/s)

$H$  = head on weir, ft (m)

$L$  = length of weir, ft (m)

$h$  = head due to velocity of approach ( $v^2/2g$ ), ft (m)

The accuracy of measurements obtained with Cipolletti weirs and these formulas is inherently not as great as that obtained with suppressed rectangular or V-notch weirs.<sup>6</sup> It is, however, acceptable where no great precision is required.

There are several well-known formulas used to compute the discharge over 90° V-notch weirs. The most commonly used in the field of irrigation are the Cone formula and the Thomson formula. The Cone formula, considered by authorities to be more reliable for small weirs and for conditions generally encountered in measuring water for open channels, is

in USCS units  $Q = 2.49H^{2.48}$

in SI units  $Q = 1.34H^{2.48}$  (7)

where  $Q$  = discharge over weir, ft<sup>3</sup>/s (m<sup>3</sup>/s)

$H$  = head on weir, ft (m)

Ordinarily V-notch weirs are not appreciably affected by velocity of approach. If the weir is installed with complete contraction, the velocity of approach will be low.

Flumes have a measuring section that is produced by contraction of the channel side-walls or by raising of the bottom to form a hump, or by both. The Parshall flume<sup>7</sup> is the most common and best known measuring flume, especially in irrigation canals. It is a specially shaped open-channel flow section that may be installed in a canal, lateral, or ditch to measure the rate of flow of water. The flume has four significant advantages: (1) it can operate with relatively small head loss, (2) it is relatively insensitive to velocity of approach, (3) it has the capability of making good measurements with no submergence, moderate submergence, or even with considerable submergence downstream, and (4) its velocity of flow is sufficiently high to virtually eliminate sediment deposition in the structure during operation.

Discharge through a Parshall flume can occur for two conditions of flow. The first, free flow, occurs when there is insufficient backwater depth to reduce the discharge rate. The second, submerged flow, occurs when the water surface downstream from the flume is far enough above the elevation of the flume crest to reduce the discharge. For free flow, only the flume head  $H_a$  at the upstream gage location is needed to determine the discharge from a standard table. The free-flow range includes some of the range that might ordinarily be considered submerged flow because Parshall flumes tolerate 50 to 80% submergence before the free-flow rate is measurably reduced. For submerged flows (when submergence is greater than 50 to 80%, depending upon flume size), both the upstream and downstream heads  $H_a$  and  $H_b$  are needed to determine the discharge (Figure 16).

A distinct advantage of the Parshall flume is its ability to function as a flowmeter over a wide operating range with minimum head loss while requiring but a single head measurement for each discharge. The head loss is only about one-fourth of that needed to operate a weir having the same crest length. Another advantage is that the velocity of approach is automatically controlled if the correct size of flume is chosen and if the flume is used as it should be, that is, as an in-line structure.

Flumes are widely used because there is no easy way to alter the dimensions of flumes that have been constructed or to change the device or channel to obtain an unfair proportion of water.

The main disadvantages of Parshall flumes are (1) they cannot be used in close-coupled combination structures consisting of turnout, control, and measuring device; (2) they are usually more expensive than weirs or submerged orifices; (3) they require a solid, water-tight foundation; and (4) they require accurate workmanship for satisfactory construction and performance.

Parshall flume sizes are designated by the throat width  $W$ , and sizes range from 1 in (25.4 mm) for discharges as small as 0.01 ft<sup>3</sup>/s ( $2.83 \times 10^{-2}$  m<sup>3</sup>/s) up to 50 ft (15 m) for discharges as large as 3000 ft<sup>3</sup>/s (85 m<sup>3</sup>/s).<sup>8</sup> Flumes may be built of wood, concrete, galvanized

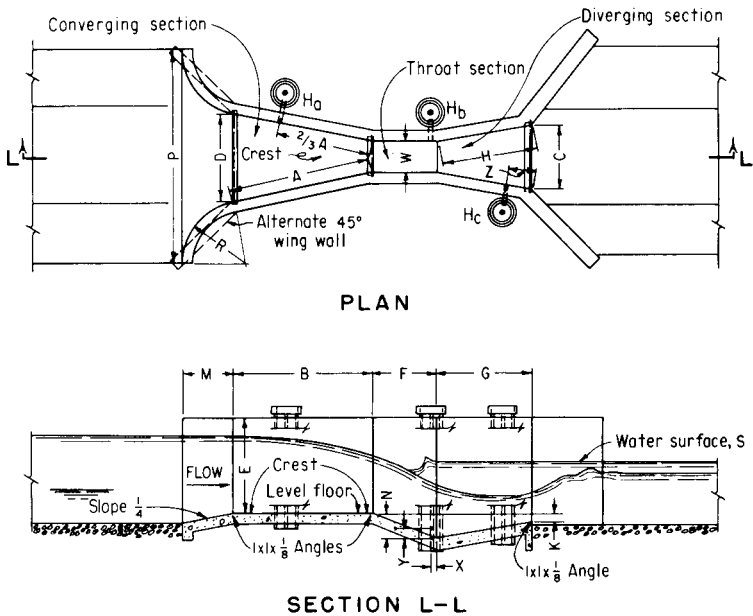


FIGURE 16A Parshall flume dimensions (sheet 1 of 2)

sheet metal, or other desired materials. Large flumes are usually constructed on the site, but smaller flumes may be purchased as prefabricated structures to be installed in one piece. Some flumes are available as lightweight shells, which are made rigid and immobile by placing concrete outside the walls and beneath the bottom. Larger flumes are used in rivers and large canals and streams; smaller ones are used for measuring farm deliveries or for row requirements in the farmer's field.

Flumes can operate in two modes: free flow and submerged flow. In free flow, the discharge depends solely upon the width of the throat  $W$  and the depth of water  $H_a$  at the gage point in the converging section (Figures 16 and 17). Free-flow conditions in the flume are similar to those that occur at a weir or spillway crest in that water passing over the crest is not slowed by downstream conditions.

In submerged flow, other factors are operative. In most installations, when the discharge is increased above a critical value, the resistance to flow in the downstream channel becomes sufficient to reduce the velocity, increase the flow depth, and cause a backwater effect at the Parshall flume. It might be expected that the discharge would begin to be reduced as soon as the backwater level  $H_b$  exceeds the elevation of the flume crest; however, this is not the case. Calibration tests show that the discharge is not reduced until the submergence ratio  $H_b/H_a$  (expressed in percent) exceeds the following values:

- 50% for flumes 1, 2, and 3 in (25, 50, and 75 mm) wide
- 60% for flumes 6 and 9 in (152 and 229 mm) wide
- 70% for flumes 1 to 8 ft (0.3 to 2.4 m) wide
- 80% for flumes 8 to 50 ft (2.4 to 15.2 m) wide

The discharge equations for free flow over flumes are as follows. The equation which expresses the relationship between upstream head  $H_a$  and discharge  $Q$  for widths  $W$  from 1 to 8 ft (0.3 to 2.4 m) is



	W		A		$\frac{2}{3}A$		B		C		D		E		F		G		H		K		M		N		P		R		X		Y		Z		FREE-FLOW CAPACITY	
																																			MINIMUM		MAXIMUM	
	FT	IN	FT	IN	FT	IN	FT	IN	FT	IN	FT	IN	FT	IN	FT	IN	FT	IN	FT	IN	FT	IN	FT	IN	FT	IN	FT	IN	FT	IN	FT	IN	FT	IN	FT	IN	SEC - FT.	SEC - FT.
2	0	1 1/2	1	2 9/32	0	9 17/32	1	2	0	3 21/32	0	6 19/32	0	6 10/9	0	3	0	8	0	8 1/8	0	3 4/8	-	-	0	1 8/16	-	-	-	0	5 5/16	0	1 1/2	0	1 8/16	.01	0.19	
		2 1/2	1	4 5/16		10 7/8	1	4		5 5/16		8 13/32		6 10/10		4 1/2		10		10 1/8		7 7/8	-	-	1 11/16	-	-	-	-	5 5/8	0	1 1/2	1	1 4/4	.02	.47		
		3 1/2	1	6 3/8	1	1 1/4	1	6		7		10 3/16		11 1/2		6	1	0	1		5 3/32		1	-	2 1/4	-	-	-	1	1 1/2	1 1/2			.03	1.13			
3	0	6	2	7 5/16	1	4 5/16	2	0	1	3 1/2	1	3 5/8	2	0	1	0	2	0	-	0	3	1	0	0	4 1/2	2	11 1/2	1	4	0	2	0	3	-	.05	3.9		
		9	2	10 5/8	1	11 5/8	2	10	1	3	1	10 5/16	2	6	1	0	1	6	-		3	1	0	4 1/2	3	6 1/2	1	4	2	2	3	-	.09	8.9				
		1	0	4	6	3	0	4	2	0	2	9 1/8	3	0	2	0	3	0	-		3	1	3	9	4	10 3/4	1	8	2	3	-	.11	16.1					
		1	6	4	9	3	2	4	2	6	3	4 3/8	3	0	2	0	3	0	-		3	1	3	9	5	6	1	8	2	3	-	.15	24.6					
		2	0	5	0	3	4	4	10	7	3	0	3	11 1/2	3	0	2	0	3	-		3	1	3	9	6	1	8	2	3	-	.42	33.1					
		3	0	5	6	3	8	5	4	3	4	0	5	7 7/8	3	0	2	0	3	0	-	3	1	3	9	7	3 1/2	1	8	2	3	-	.61	50.4				
		4	0	6	0	4	0	5	10 2/8	5	0	6	4 1/4	3	0	2	0	3	0	-		3	1	6	9	8	10 3/4	2	0	2	3	-	1.3	67.9				
		5	0	6	4	4	6	4	1 1/2	6	0	7	6 3/8	3	0	2	0	3	0	-		3	1	6	9	10	1 1/4	2	0	2	3	-	1.6	85.6				
		6	0	7	0	4	8	6	10 3/8	7	0	8	8	3	0	2	0	3	0	-		3	1	6	9	11	3 1/2	2	0	2	3	-	2.6	103.5				
		7	0	7	6	5	0	7	4 1/4	8	0	9	11 3/8	3	0	2	0	3	0	-		3	1	6	9	12	6	2	0	2	3	-	3.0	121.4				
	8	0	8	0	5	4	7	10 7/8	9	0	11	1 3/4	3	0	2	0	3	0	-		3	1	6	9	13	8 1/4	2	0	2	3	-	3.5	139.5					
4	10	0	-		6	0	14	0	12	0	15	7 1/4	4	0	3	0	6	0	-	0	6	-	1	1 1/2	-	-	-	0	9	1	0	-	6	200				
	12	0	-		6	8	16	0	14	8	18	4 3/4	5	0	3	0	8	0	-		6	-	1	1 1/2	-	-	-	9	1	0	-	8	350					
	15	0	-		7	8	25	0	18	4	25	0	6	0	4	0	10	0	-		9	-	1	6	-	-	-	9	1	0	-	8	600					
	20	0	-		9	4	25	0	24	0	30	0	7	0	6	0	12	0	-		1	0	-	2	3	-	-	9	1	0	-	10	1000					
	25	0	-		11	0	25	0	29	4	35	0	7	0	6	0	13	0	-		1	0	-	2	3	-	-	9	1	0	-	15	1200					
	30	0	-		12	8	26	0	34	8	40	4 3/4	7	0	6	0	14	0	-		1	0	-	2	3	-	-	9	1	0	-	15	1500					
	40	0	-		16	0	27	0	45	4	50	9 1/2	7	0	6	0	16	0	-		1	0	-	2	3	-	-	9	1	0	-	20	2000					
	50	0	-		19	4	27	0	56	8	60	9 1/2	7	0	6	0	20	0	-		1	0	-	2	3	-	-	9	1	0	-	25	3000					

1) Tolerance on throat width (w)  $\pm \frac{1}{64}$  inch; tolerance on other dimensions  $\pm \frac{1}{32}$  inch. Sidewalls of throat must be parallel and vertical.

2) From Colorado State University Technical Bulletin No. 61.

3) From U.S. Department of Agriculture Soil Conservation Circular No. 843.

4) From Colorado State University Bulletin No. 426-A.

FIGURE 16B Parshall flume dimensions (sheet 2 of 2.) (1 ft = 0.3048 m; ft<sup>3</sup>/s = 0.0253 m<sup>3</sup>/s)

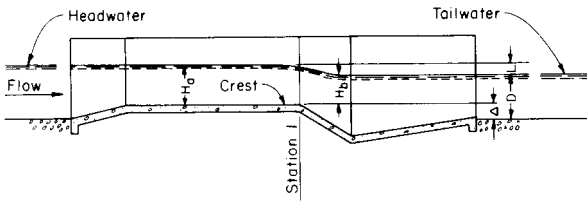


FIGURE 17 Relationships of flow depth to flume crest elevation

in USCS units

$$Q = 4WH_a^{1.522}W^{0.026}$$

in SI units

$$Q = 0.371W \left( \frac{Ha}{0.305} \right)^{1.57}W^{0.026}$$

If this equation is used to compute discharges through flumes ranging from 10 to 50 ft (3 to 15.7 m) wide, the computed discharges are always larger than actual discharges. Therefore, a more accurate equation was developed for the large flumes:

In USCS units

$$Q = (3.6875W + 2.5)H_a^{1.6}$$

In SI units

$$Q = (2.293W + 0.474)H_a^{1.6}$$

This difference in computed discharges obtained by using the two equations for an 8-ft (2.4-m) flume is normally less than 1%; however, the difference becomes greater as the flume size increases. Because of the difficulties in regularly using these equations, discharge tables have been prepared for use with flumes 1 to 50 ft (0.3 to 15.2 m) wide.

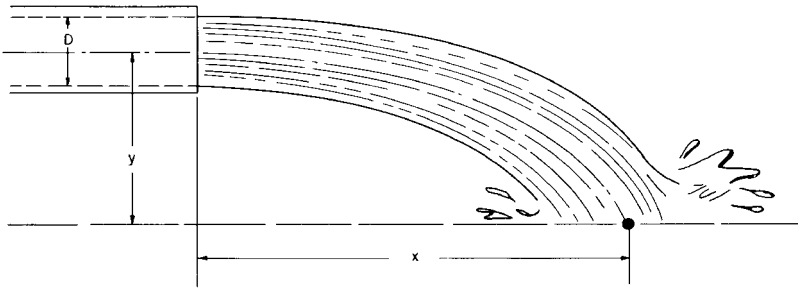
**CURRENT METERS** The essential features of a conventional current meter are a wheel that rotates when immersed in flowing water and a device for determining the number of revolutions of the wheel. For open-channel flow measurement, a type generally used is the Price meter with five or six conical cups. The relationship between the velocity of the water and the number of revolutions of the wheel per unit time is determined experimentally for each instrument for various velocities. Also, the operator must have considerable skill to obtain consistent satisfactory results.

A detailed explanation of the use of current meters is contained in Chapter 5 of Reference 9.

**OTHER METHODS** The discharge measurement methods previously given are the ones in common use; however, a number of other methods, some newer and more sophisticated, are well established. The use of these special methods is acceptable provided their limitations are recognized and all parties to the testing program are in agreement on their use. A few of these methods, not in any particular order, are

Salt velocity	Deflection meters	Radioisotope	Color dilution
Salt dilution	Propeller meters	Gates and sluices	Slope area
Color velocity	Float movement	Acoustic flowmeters	

**FIELD APPROXIMATING** Often a field approximation of water flow from a pump discharge becomes necessary, especially if no other methods are practical or readily available. One of the accepted methods is by trajectory. The discharge from the pipe may be either vertical or horizontal, the principal difficulty being in measuring the coordinates of the flowing stream accurately. The pipes must be flowing full, and the accuracy of this method varies from 85 to 100%. Figure 18 illustrates the approximation from a horizontal pipe. This method can be further simplified by measuring to the top of the flowing stream and



$$\text{CAPACITY, GPM} = \frac{2.45 D^2 x}{\sqrt{\frac{2y}{32.16}}} \quad \text{CAPACITY, m}^3/\text{h} = \frac{0.00283 D^2 x}{\sqrt{\frac{2y}{9.81}}}$$

Where as  
 D = Pipe Dia., Inches (mm)  
 x = Hor. Dist., Feet (m)  
 y = Vert. Dist., Feet (m)

FIGURE 18 Approximating flow from a horizontal pipe

always measuring so  $y$  equals 12 in (300 mm) and measuring the horizontal distance  $X$  in inches (millimeters), as illustrated in Figure 19.

Figure 20 illustrates a method of measuring discharge from a vertical pipe.

**Head Measurements** Head is the quantity used to express the energy content of a liquid per unit weight of the liquid referred to any arbitrary datum. In terms of foot-pounds of energy per pound of liquid, all head quantities have the dimensions of feet of liquid. The unit for measuring head is the foot (meter). The relation between a pressure expressed in pounds per square inch (kilopascals) and one expressed in feet (meters) of head is

$$\text{in USCS units} \quad \text{Head, ft} = \text{lb/in}^2 \times \frac{2.31 \times 62.3}{W} = \text{lb/in}^2 \times \frac{2.31}{\text{sp. gr.}}$$

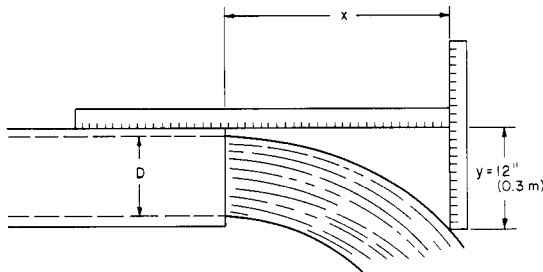
$$\text{in SI units} \quad \text{Head, m} = \frac{0.102 \times \text{kPa}}{W}$$

where  $W$  = specific weight (mass), lb/ft<sup>3</sup> (kg/l)  
 sp. gr. = specific gravity of the liquid

The following excerpt from the *Hydraulic Institute Standard* is used by the Bureau of Reclamation throughout its test program:

*It is important that steady flow conditions exist at the point of instrument connection. For this reason, it is necessary that pressure or head measurement be taken on a section of pipe where the cross section is constant and straight. Five to ten diameters of straight pipe of unvarying cross section following any elbow or curved member, valve, or other obstruction, are necessary to insure steady flow conditions.*

The following precautions should be taken in forming orifices for pressure-measuring instruments and for making connections. The orifice in the pipe should be flush with and normal to the wall of the water passage. The wall of the water passage should be smooth and of unvarying cross section. For a distance of at least 12 in (0.8 m) preceding the orifice, all tubercles and roughness should be removed with a file or emery cloth, if necessary. The orifice should be from  $\frac{1}{8}$  to  $\frac{1}{4}$  in (3–6 mm) in diameter and two diameters long.



CAPACITY, GPM =  $0.818 D^2 X$   
 CAPACITY,  $m^3/h = 1.1336 \times 10^{-5} D^2 X$   
 $D = \text{in (mm)}$   
 $X = \text{in (mm)}$   
 APPROXIMATE CAPACITY, GPM,  
 FOR FULL FLOWING HORIZONTAL PIPES

STD. WT. STEEL  
 PIPE, INSIDE  
 DIA., IN.

DISTANCE X, IN., WHEN Y = 12"

NOMINAL	ACTUAL	12	14	16	18	20	22	24	26	28	30	32
2	2.067	42	49	56	63	70	77	84	91	98	105	112
2½	2.469	60	70	80	90	100	110	120	130	140	150	160
3	3.068	93	108	123	139	154	169	185	200	216	231	246
4	4.026	159	186	212	239	266	292	318	345	372	398	425
5	5.047	250	292	334	376	417	459	501	543	585	627	668
6	6.065	362	422	482	542	602	662	722	782	842	902	962
8	7.981	627	732	837	942	1047	1150	1255	1360	1465	1570	1675
10	10.020	980	1145	1310	1475	1635	1800	1965	2130	2290	2455	2620
12	12.000	1415	1650	1890	2125	2360	2595	2830	3065	3300	3540	3775

FIGURE 19 Simplified method for approximating flow from a horizontal pipe (1 in = 25.4 mm; 1 gpm = 0.227  $m^3/h$ ).

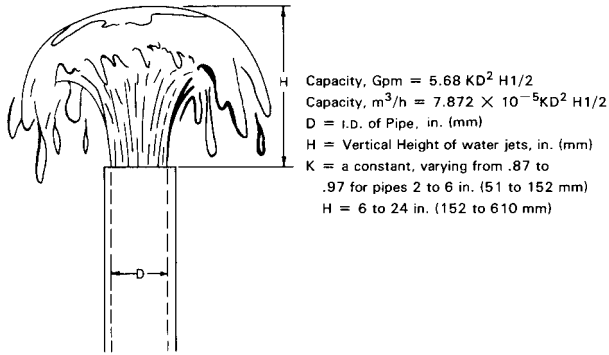
The edges of the orifice should be provided with a suitable radius tangential to the wall of the water passage and should be free from burrs or irregularities. Two pressure tap arrangements shown in Figure 27 indicate taps in conformity with the above. Where more than one tap is required at a given measuring section, separate properly valved connections should be made. As an alternative, separate instruments should be provided.

Multiple orifices should not be connected to one instrument except on those metering devices, such as venturi meters, where proper calibrations have been made.

All leads from the orifice should be tight and as short and direct as possible. For dry-tube leads, suitable drain pots should be provided and a loop of sufficient height to keep the pumped liquid from entering the leads should be formed. For wet-tube leads, vent cocks for flushing should be provided at any high point or loop crest to assure that tubes do not become airbound. All instrument hose, piping, and fittings should be checked under pressure prior to test to assure that there are no leaks. Suitable damping devices may be used in the leads.

If these conditions cannot be satisfied at the point of measurement, it is recommended that four separate pressure taps be installed, equally spaced about the pipe, and that the pressure at that section be taken as the average of the four separate values. If the separate readings show a difference of static pressure that might affect the head beyond the contract tolerances, the installation should be corrected or an acceptable tolerance determined.

Figures 21 to 27 show suitable arrangements for various types of instruments and formulas for translating instrument readings into feet (meters) of liquid pumped, for expressing instrument head as elevation over a common datum, and for correcting these formulas for the velocity head existing in the suction and discharge pipes.



APPROXIMATE CAPACITY, GPM,  
 FOR FLOW FROM VERTICAL PIPES

NOMINAL I.D. PIPE, IN.	VERTICAL HEIGHT, H, OF WATER JET, IN.										
	3	3.5	4	4.5	5	5.5	6	7	8	10	12
2	38	41	44	47	50	53	56	61	65	74	82
3	81	89	96	103	109	114	120	132	141	160	177
4	137	151	163	174	185	195	205	222	240	269	299
6	318	349	378	405	430	455	480	520	560	635	700
8	567	623	684	730	776	821	868	945	1020	1150	1270
10	950	1055	1115	1200	1280	1350	1415	1530	1640	1840	2010

FIGURE 20 Approximating flow from a vertical pipe (1 in = 25.4 mm; 1 gpm = 0.227  $m^3/h$ )

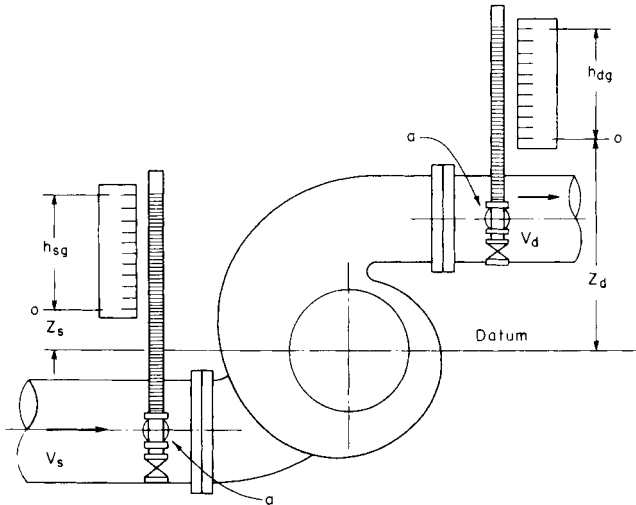


FIGURE 21 Head measurement

$$h_d = +h_{\theta d} + Z_d + \frac{V_d^2}{2g}$$

$$h_s = +h_{\theta s} + Z_s + \frac{V_s^2}{2g}$$

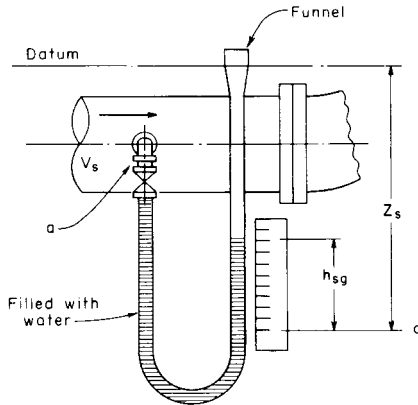


FIGURE 22 Head measurement

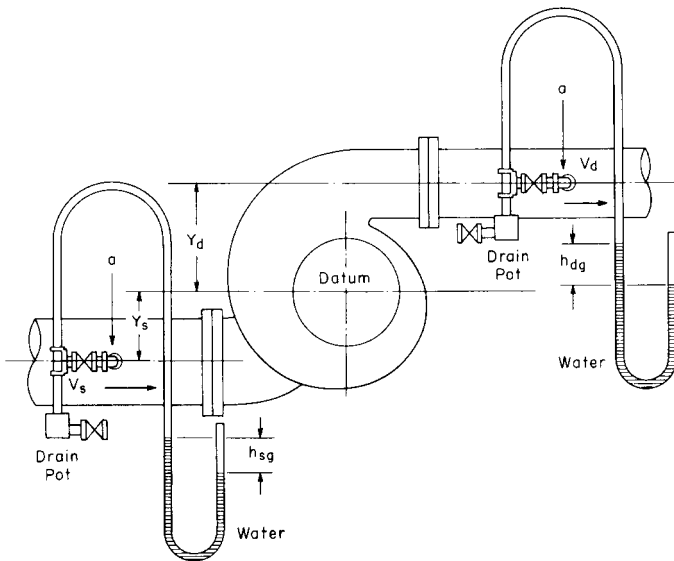


FIGURE 23 Head measurement

The datum is taken as the centerline of the pump for horizontal-shaft pumps and as the entrance eye of the impeller for vertical-shaft pumps.

The instruments, when practicable, are water columns or manometers for normal pressures and mercury manometers, bourdon gages, electric pressure transducers, or dead-weight gage testers for high pressure. When water columns are used, care should be taken

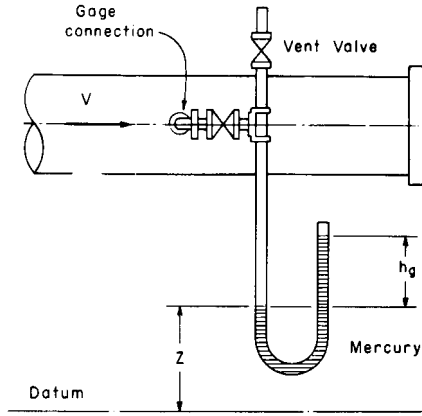


FIGURE 24 Head measurement

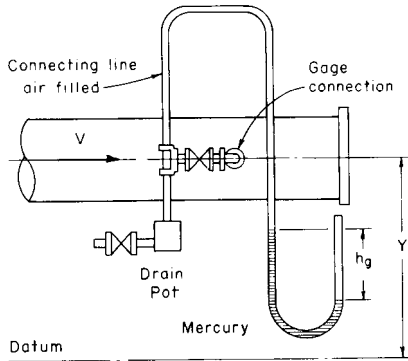


FIGURE 25 Head measurement

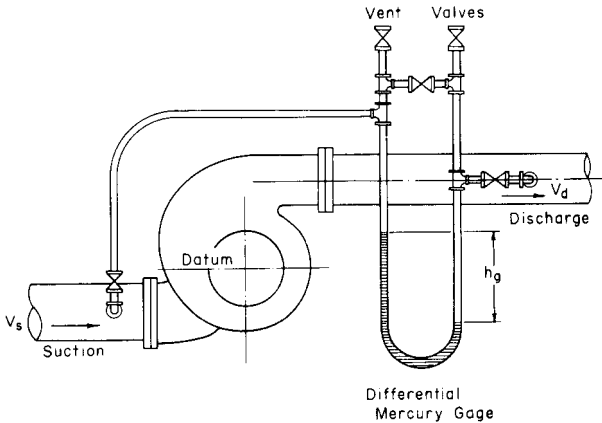
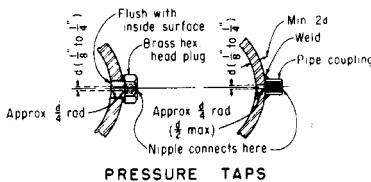
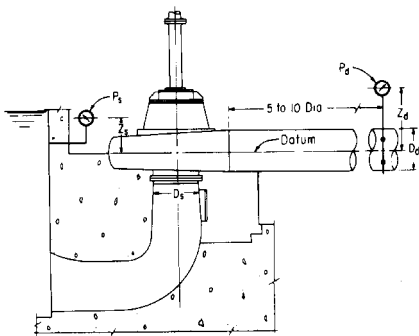
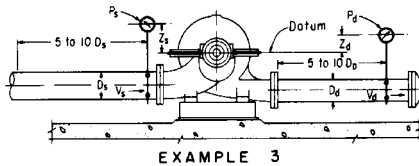
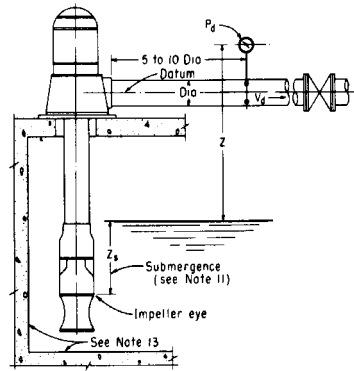
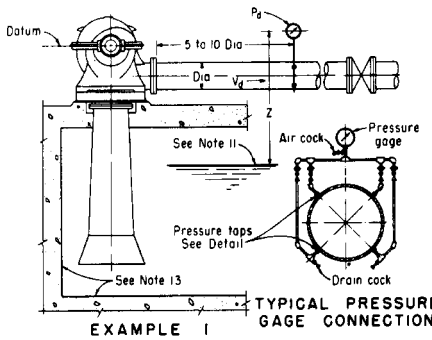


FIGURE 26 Head measurement



IRRIGATION AND DRAINAGE PUMPS  
LABORATORY AND FIELD TESTING  
MEASUREMENT OF TOTAL HEAD

NOTES

- 1 H = Total head required by specifications in feet
- 2  $P_s$  = Suction pressure gage reading, pounds per square inch gage
- 3  $P_d$  = Discharge pressure gage reading, pounds per square inch gage
- 4  $V_s$  = Velocity in suction, feet per second
- 5  $V_d$  = Velocity in discharge, feet per second
- 6 Z = Distance in feet center of gage above or below datum. Z is negative when gage is below datum.  $Z_s$  and  $Z_d$  refer to suction and discharge gages respectively.
- 7 W = Specific weight of liquid pumped, pounds per cubic foot
- 8 For Example 1 and 2  
 $H = \frac{144 P_s}{W} + Z + \frac{V_s^2}{2g}$
- 9 For Example 3,  $H = h_s + h_d - h_s$  where  
 $h_d = \frac{144 P_d}{W} + Z_d + \frac{V_d^2}{2g}$   
 $h_s = \frac{144 P_s}{W} + Z_s + \frac{V_s^2}{2g}$
- 10 For Example 4,  $H = h_d - h_s$   
 $h_d = \frac{144 P_d}{W} + Z_d + \frac{V_d^2}{2g}$   
 $h_s = \frac{144 P_s}{W} + Z_s$
- 11 For Example 1 and 2, sump water surfaces shall be measured at two or more points. Laboratory static lift shall be corrected to reflect altitude (feet above sea level) of installation.
- 12 Pump shall be driven with the motor furnished with the unit.
- 13 For additional information regarding tests and hydraulic duplication of field conditions, see Standards of the Hydraulic Institute Standards for Centrifugal Pumps (2<sup>nd</sup> Edition).
- 14 Laboratory tests require the installation of partitions representing the floor and walls of the sump according to field conditions.

FIGURE 27 Head measurement. In SI units,  $hd = [(0.102 P_d / W) + Z_d + (V_d^2 / 2g)]$ ;  $h_s = [(0.102 P_s / W) + Z_s + (V_s^2 / 2g)]$ . (ft  $\times 0.3048 = m$ ; psi  $\times 6.894 = kPa$ ; pcf  $\times .016 = kg/liter$ )

to avoid errors due to the difference between the temperature of the water in the gage and that of the water in the pump.

DEFINITIONS AND SYMBOLS The symbols used throughout this section for expressing and computing head are those used by the ASME Power Test Code<sup>1</sup> for pumps and the Hydraulic Institute ANSI/HI 2000 Edition Pump Standards (Reference 13). The following symbols apply to Figures 21 to 27 where temperature effects are negligible:



$H$  = total head or dynamic head, ft (m) = the energy increase per pound (kilogram) of liquid imparted to the liquid by the pump and therefore the algebraic difference between total discharge head and total suction head ( $H = h_d - h_s$ );  $h_d$  and  $h_s$  are negative if the corresponding values at the datum elevation are below atmospheric pressure

$h_{gd}$  = discharge gage reading, ft (m)  $H_2O$

$h_{gs}$  = suction gage reading, ft (m)  $H_2O$

Both the discharge gage and the suction gage can be direct-reading water manometers, converted mercury manometers, or calibrated bourdon pressure gages.

$Z_d$  = elevation of discharge gage, zero above datum elevation, ft (m)

$Z_s$  = elevation of suction gage, zero above datum elevation, ft (m)

The quantities  $Z_d$  and  $Z_s$  are negative if the gage zero is below the datum elevation.

$Y_d$  = elevation of discharge gage connection to discharge pipe above datum elevation, ft(m)

$Y_s$  = elevation of suction gage connection to suction pipe above datum elevation, ft (m)

The quantities  $Y_d$  and  $Y_s$  are negative if the gage connection to the pipe lies below the datum elevation.

$V_d$  = average water velocity in discharge pipe at discharge gage connection, ft/s (m/s)

$V_s$  = average water velocity in suction pipe at suction gage connection, ft/s (m/s)

$h_d$  = total discharge head above atmospheric pressure at datum elevation, ft (m)

$h_s$  = total suction head above atmospheric pressure at datum elevation, ft (m)

$h_{vs}$  = velocity head in suction pipe ( $V_s^2/2g$ ), ft (m)

$h_{vd}$  = velocity head in discharge pipe ( $V_d^2/2g$ ), ft (m)

**NPSHA** = net positive suction head available = total suction head in feet (meters) of liquid absolute, determined at suction nozzle and referred to datum less absolute vapor pressure of the liquid in feet (meters) of liquid pumped ( $NPSHA = h_a - H_{vpa} + h_s$ )

$h_{sa}$  = total suction head absolute ( $h_a + h_s$ )

$H_{vpa}$  = vapor pressure of liquid, ft (m) abs

$h_a$  = atmosphere pressure, ft (m) abs

**MEASURING HEAD WITH WATER GAGES** The following examples illustrate how to calculate the head in a centrifugal pump arrangement with gages either above or below atmospheric pressure.

**EXAMPLE** The pressure at gage connection  $a$  in Figure 21 is above atmospheric pressure, and the line between either the discharge or suction pipe and the corresponding gage is filled completely with water. The following equations apply:

$$h_d = +h_{gd} + Z_d + \frac{V_d^2}{2g}$$

$$h_s = +h_{gs} + Z_s + \frac{V_s^2}{2g}$$

*Note:* The word *water* is used to represent the liquid being pumped. The provisions are applicable to the pumping of other liquids, provided the gages and connecting lines contain the liquid being pumped.

**EXAMPLE** The pressure at gage connection *a* in Figure 22 is below atmospheric pressure. The following equation applies:

$$h_s = h_{gs} - Z_s + \frac{V_s^2}{2g}$$

The negative sign of  $Z_s$  indicates that the gage zero is located below the datum.

**EXAMPLE** The pressure at gage connection *a* in Figure 23 is below atmospheric pressure, and the line between either the discharge or suction pipe and the corresponding gage is filled completely with air. The following equations apply:

$$h_d = -h_{gd} + Y_d + \frac{V_d^2}{2g}$$

$$h_s = -h_{gs} - Y_s + \frac{V_s^2}{2g}$$

*Note:* If a connecting pipe is air-filled, it must be drained before a reading is made. Water cannot be used in the U tube if either  $h_{dg}$  or  $h_{ds}$  exceeds the height of the rising loop.

**MEASURING HEAD WITH MERCURY GAGES\*** The following examples illustrate the use of mercury gages for measuring head in a centrifugal pump arrangement.

**EXAMPLE** In Figure 24, the gage pressure is above atmospheric pressure and the connecting line is completely filled with water. The following equation applies:

$$h = \frac{W_m}{W} h_g + Z + \frac{V^2}{2g}$$

where  $W_m$  = specific weight (mass) of mercury, lb/ft<sup>3</sup> (kg/liter)

$W$  = specific weight (mass) of liquid pumped, lb/ft<sup>3</sup> (kg/liter)

$h_g$  = suction or discharge gage reading, ft (m) Hg

The quantities  $h$ ,  $Z$ ,  $Y$ , and  $V$  without subscripts apply equally to suction and discharge head measurements.

**EXAMPLE** The gage pressure in Figure 25 is below atmospheric pressure, and the connecting line is completely filled with air, with a rising loop to prevent water from passing to the mercury column. The following equation applies

$$h = \frac{W_m}{W} h_g = Y + \frac{V^2}{2g}$$

**MEASURING HEAD WITH DIFFERENTIAL MERCURY GAGES\*** Figure 26 indicates a centrifugal pump arrangement in which a differential mercury gage is used to measure head. When

\**Note:* The use of mercury is restricted because of its toxicity. Alternative liquids or alternative measuring devices are commonly used to avoid mercury contamination.

this type of gage is used and the connecting lines are completely filled with water, the correct equation is

$$H = \left( \frac{W_m}{W} - 1 \right) h_g + \frac{V_d^2}{2g} - \frac{V_s^2}{2g}$$

In addition to the differential gage, a separate suction gage can be used, as shown in Figures 22 and 25. The equation in this case is

$$h_s = \frac{W_m}{W} h_{gs} - Z + \frac{V_s^2}{2g}$$

**MEASURING HEAD WITH BOURDON GAGES** An example of a centrifugal pump arrangement that uses calibrated bourdon gages for head measurement is shown in Example 3 of Figure 27, with the gage pressure above atmospheric pressure. The distances  $Z_s$  and  $Z_d$  are measured to the center of the gage and are negative if the center of the gage lies below the datum line.

**MEASURING HEAD ON VERTICAL SUCTION PUMPS IN SUMPS AND CHANNELS** In vertical-shaft pumps drawing water from large open sumps and having inlet passages whose length does not exceed about three inlet opening diameters, such inlet pieces having been furnished as part of the pump, the total head should be the reading of the discharge connection in feet (meters) plus the vertical distance from the gage centerline to the free water level in the sump in feet (meters) (Example 2 of Figure 27).

**Power Measurement** The pump input power may be determined with a calibrated motor, a transmission dynamometer, or a torsion dynamometer. The Hydraulic Institute ANSI/HI 2000 Edition Pump Standards (Reference 13) are generally used as the basis for most power measurement procedures.

**CALIBRATED MOTORS** When pump input power is to be determined with a calibrated motor, the power input should be measured at the terminals of the motor to exclude any line losses that may occur between the switchboard and the driver. Certified calibration curves of the motor must be obtained. The calibration should be conducted on the motor in question and not on a similar machine. Such calibrations must indicate the true input-output value of motor efficiency and not some conventional method of determining an arbitrary efficiency. Calibrated laboratory-type electric meters and transformers should be used to measure power input to all motors.

**TRANSMISSION DYNAMOMETERS** The transmission, or torque-reaction, dynamometer consists of a cradled electric motor with its frame and field windings on one set of bearings and the rotating element on another set, so the frame is free to rotate but is restrained by means of some weighting or measuring device.

When pump input power is to be determined with a transmission dynamometer, the unloaded and unlocked dynamometer must be properly balanced prior to the test at the same speed at which the test is to be run. The balance should be checked against standard weights. After the test the balance must be rechecked to assure that no change has taken place. In the event of an appreciable change, the test should be rerun. An accurate measurement of speed is essential and should not vary from the pump rated speed by more than 1%. Power input is calculated as shown later in this section under "Computations."

**TORSION DYNAMOMETERS** The torsion dynamometer consists of a length of shafting whose torsional strain when rotating at a given speed and delivering a given torque is measured by some standard method. When pump input power is to be determined with a torsion dynamometer, the unloaded dynamometer should be statically calibrated prior to the test. This is done by measuring the angular deflection for a given torque.

Immediately before and after the test, the torsion dynamometer must be calibrated dynamically at the rated speed. The best and simplest method to accomplish this is to use the actual job driver to supply power and use a suitable method of loading the driver over the entire range of the pump to obtain the necessary calibrations. The calibration of the

torsion dynamometer after the pump tests should be within 0.5% of the original calibration. During the test runs the speed should not vary from the pump rated speed by more than 1%. The temperature of the torsion dynamometer during the test runs must be within 10°F (6°C) of the temperature when the dynamic calibrations were made. All torsion dynamometer calibrations should be witnessed and approved by all parties to the test. In the event of a variation greater than allowed, a rerun of the test must be made. Power input calculations are shown in the following text.

**Speed Measurement** The speed of the pump under test is determined by one of the following methods:

- Revolution counter (manual or automatic)
- Tachometer
- Stroboscopic device
- Electronic counter

In all cases, the instruments used must be carefully calibrated before the test to demonstrate that they will produce the required speed readout to within the desired accuracy. Accepted accuracy is usually  $\pm 0.1\%$ . Should cyclic speed change result in power fluctuations, at least five equally spaced, timed readings should be taken to give a satisfactory mean speed.

## COMPUTATIONS

---

### Pump Power

**POWER OUTPUT** The water power, or useful work, done by the pump is found by the formula

$$\text{in USCS units} \quad \text{whp} = \frac{\text{lb of liquid pumped/min} \times \text{total head in ft of liquid}}{33,000}$$

$$\text{in SI units} \quad \text{wkW} = \frac{\text{kg of liquid pumped/min} \times \text{total head in m of liquid}}{6131}$$

If the liquid has a specific gravity of 1 and the specific weight of the liquid is 62.3 lb/ft<sup>3</sup> (1.0 kg/liter) at 68°F (20°C), the formula is

$$\text{in USCS units} \quad \text{whp} = \frac{\text{gpm} \times \text{head in ft}}{3960}$$

$$\text{in SI units} \quad \text{wkW} = 9.8 \text{ m}^3/\text{h} \times \text{head in m}$$

**POWER INPUT** The brake power required to drive the pump is found by the formula

$$\text{in USCS units} \quad \text{bhp} = \frac{\text{gpm} \times \text{total head in ft}}{3960 \times \text{pump efficiency}}$$

$$\text{in SI units} \quad \text{bkW} = \frac{9.8 \text{ m}^3/\text{h} \times \text{total head in m}}{\text{pump efficiency}}$$

where pump efficiency is obtained from the formula

$$\text{Pump efficiency} = \frac{\text{output}}{\text{input}} = \frac{\text{whp}}{\text{bhp}} = \frac{\text{wkW}}{\text{bkW}}$$

(used as a decimal)

The electric power input to the motor is

$$\text{in USCS units} \quad \text{ehp} = \frac{\text{bhp}}{\text{motor efficiency}} = \frac{\text{gpm} \times \text{head in ft}}{3960 \times \text{pump efficiency} \times \text{motor efficiency}}$$

$$\text{in SI units} \quad \text{kW} = \frac{9.8 \text{ m}^3/\text{h} \times \text{head in m}}{\text{pump efficiency} \times \text{motor efficiency}}$$

The kilowatt input to the motor is

$$\begin{aligned} \text{kW input} &= \frac{\text{bhp} \times 0.746}{\text{motor efficiency}} \\ &= \frac{\text{gpm} \times \text{head} \times 0.746}{3960 \times \text{pump efficiency} \times \text{motor efficiency}} \end{aligned}$$

**Pump Efficiency** The pump efficiency is

$$\text{Pump efficiency} = \frac{\text{output}}{\text{input}} = \frac{\text{whp}}{\text{bhp}} = \frac{\text{wkW}}{\text{bkW}}$$

For an electric-motor-driven pumping unit, the overall efficiency is

$$\text{Overall efficiency} = \text{pump efficiency} \times \text{motor efficiency}$$

In many specifications, it is required that the actual job motor be used to drive the pump during shop or field testing. Using this test setup, the overall efficiency then becomes what is commonly called “wire-to-water” efficiency, which is expressed by the formula

$$\text{Overall efficiency} = \frac{\text{water power}}{\text{electric power input}} = \frac{\text{whp}}{\text{ehp}} = \frac{\text{wkW}}{\text{kW}}$$

**Speed Adjustments** The best and standard practice in testing pump speed is to use the actual job motor to drive the pump under test. However, for purposes of plotting test results, it becomes necessary to correct the test values at test speed to rated pump speed. The rated pump speed should always be less than the test speed because even a small increase in speed beyond the test speed may result in going into an unstable zone of the pump. Also, it is recommended that the speed change from test speed to rated or specified speed not be greater than 3%.

To adjust pump flow rate, head, power, and *NPSH* from the values recorded during test to another speed, the following formulas<sup>(10)</sup> should be used:

$$\text{Capacity:} \quad Q_2 = \frac{N_2}{N_1} \times Q_1$$

where  $Q_1$  = flow rate at test speed, gpm ( $\text{m}^3/\text{h}$ )

$Q_2$  = flow rate at rated speed, gpm ( $\text{m}^3/\text{h}$ )

$N_1$  = test speed, rpm

$N_2$  = rated speed, rpm

$$\text{Head:} \quad H_2 = \left(\frac{N_2}{N_1}\right)^2 \times H_1$$

where  $H_1$  = head at test speed, ft (m)

$H_2$  = head at rated speed, ft (m)

Power:

$$\text{in USCS units} \quad \text{hp}_2 = \left(\frac{N_2}{N_1}\right)^3 \times \text{hp}_1$$

in SI units 
$$kW_2 = \left(\frac{N_2}{N_1}\right)^3 \times kW_1$$

where  $hp_1$  = power at test speed, hp  
 $hp_2$  = power at rated speed, hp  
 $kW_1$  = power at test speed, kW  
 $kW_2$  = power at rated speed, kW

Net positive suction head: 
$$NPSH_2 = \left(\frac{N_2}{N_1}\right)^2 \times NPSH_1$$

where  $NPSH_1$  = net positive suction head at test speed, ft (m)  
 $NPSH_2$  = net positive suction head at rated speed, ft (m)

Shop or field testing at either reduced or increased speed should be permitted only when absolutely no alternatives are available. It is recommended, if reduced or increased speed tests are used as official performance tests, that the specifications state the test head and speed and that the performance warranties be based on the specified head and speed conditions.

If reduced or increased speed tests are considered, certain affinity laws must be observed to maintain hydraulic similarity between actual and test conditions. These affinity law relationships can be expressed by

$$\frac{Q_1}{Q} = \frac{N_1}{N} = \left(\frac{H_1}{H}\right)^{1/2}$$

where test =  $Q_1$  = flow rate and  $H_1$  = head at  $N_1$  = rpm  
 actual =  $Q$  = flow rate and  $H$  = head at  $N$  = rpm

## RECORDS

---

**Data** There probably are as many test data forms as there are test laboratories. Each may or may not have an advantage for its particular application. A form for recording pump performance data is shown in Figure 28.

The manufacturer's serial number, type, and size or other means of identification of each pump and driver involved in the test should be carefully recorded in order that mistakes in identity may be avoided. The dimensions and physical conditions not only of the machine tested but of all associated parts of the plant which have any important bearing on the outcome of a test, should be noted.

Normal practice suggests that one test run be either at or as near as possible to the rated condition and that at least three runs be within the specified range of heads.

**Plotting Test Results** In plotting curves from the test results, it should be kept in mind that any one point may be in error but that all the points should establish a trend.

Unless some external factor is introduced to cause an abrupt change, a smooth curve can be drawn for the points plotted, not necessarily through each and every one. Figure 29 is a graphic representation showing the determination of pump performance with the total head, power input, and efficiency in percent, all plotted on the same graph with the capacity as the abscissa.

**Reports** In some instances a preliminary report may be issued as part of a contract agreement. However, normally a final report is all that is required.

On shop tests of relatively small pumps, the test log and plotted results constitute the entire report. Reports get progressively more involved as pumps become larger. Where

### RECORD OF PUMP PERFORMANCE TEST

DATE OF TEST \_\_\_\_\_ TEST NO. \_\_\_\_\_ CUSTOMER \_\_\_\_\_ CUST. ORDER NO. \_\_\_\_\_  
 MANUFACTURER'S ORDER NO. \_\_\_\_\_ PLANT \_\_\_\_\_ UNIT NO. \_\_\_\_\_  
 PROJECT \_\_\_\_\_

RATED CONDITIONS:  
 CAPACITY, G.P.M. (m<sup>3</sup>/h) \_\_\_\_\_ TOTAL HEAD, FEET (m) \_\_\_\_\_ R. P.M. \_\_\_\_\_  
 OVERALL EFFICIENCY PERCENT \_\_\_\_\_ RANGE OF HEAD \_\_\_\_\_

DRIVER:  
 TYPE \_\_\_\_\_ HORSEPOWER (kW) \_\_\_\_\_  
 MANUFACTURER \_\_\_\_\_ SERIAL NO. \_\_\_\_\_ TEST VOLTAGE \_\_\_\_\_

TEST EQUIPMENT:  
 DISCHARGE MEASUREMENT METHOD \_\_\_\_\_ CONVERSION FACTOR \_\_\_\_\_  
 DISCHARGE GAGE \_\_\_\_\_ CORRECTION \_\_\_\_\_ SUCTION GAGE \_\_\_\_\_ CORRECTION \_\_\_\_\_  
 DIFFERENTIAL BETWEEN GAGES \_\_\_\_\_ INSIDE DIAMETER SUCTION \_\_\_\_\_ INSIDE DIAMETER DISCHARGE \_\_\_\_\_

PUMP DATA:  
 TYPE OF PUMP \_\_\_\_\_ SIZE \_\_\_\_\_ NO. STAGES \_\_\_\_\_  
 MANUFACTURER \_\_\_\_\_ SERIAL NO. \_\_\_\_\_ SUCTION SIZE \_\_\_\_\_ DISCHARGE SIZE \_\_\_\_\_

RUN NO.		1	2	3	4	5	6	7	8	9	10
HEAD	PRESSURE, P.S.I. (kPa)										
	HEAD, FEET (m)										
	GAGE $\epsilon$ TO WATER LEVEL, FEET (m)										
	VELOCITY HEAD, FEET (m)										
	TOTAL HEAD, FEET (m)										
CAPACITY	READING										
	CONVERSION										
	FLOW, G.P.M. (m <sup>3</sup> /h)										
POWER DATA	MOTOR VOLTAGE										
	AMPERES										
	KILOWATTS										
	TOTAL HORSEPOWER INPUT										
	MOTOR EFFICIENCY, %										
	SPEED, R.P.M.										
	DYNAMOMETER										
	BRAKE HORSEPOWER (kW)										
	WATER HORSEPOWER (kW)										
	PUMP EFFICIENCY, %										
OVERALL EFFICIENCY, %											

TESTED BY \_\_\_\_\_ WITNESSED BY \_\_\_\_\_  
 TYPE OF TEST \_\_\_\_\_  
 (FIELD OR SHOP)  
 REMARKS:  
 \_\_\_\_\_  
 \_\_\_\_\_

FIGURE 28 Record of pump performance test

model testing is used, the final report is a complete record of the agreements, inspections, personnel, calibration data, sample computations, tabulations, descriptions, discussions, etc.

## MODEL TESTING

Models are tested for one or more of the following purposes:

1. To develop new ideas and new designs
2. To give the manufacturer a range of warranties for performance and efficiency

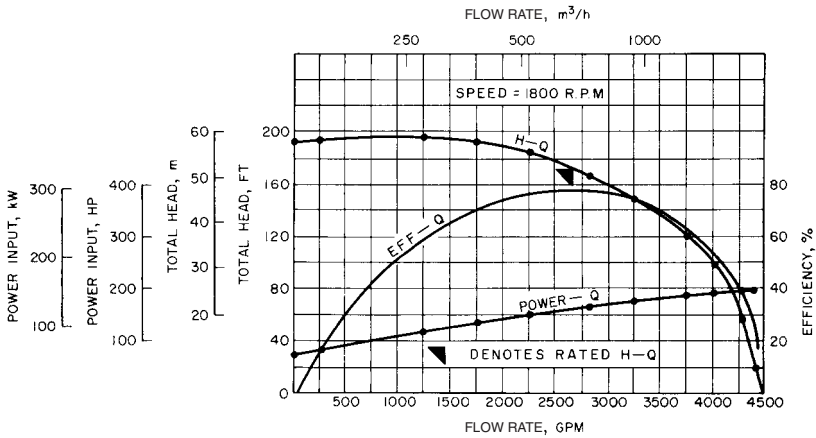


FIGURE 29 Plotted pump performance

3. To give the buyer some assurance that requirements are being met
4. To replace or supplement field testing of a prototype
5. To compare performances of several models

Model testing in advance of final design and installation of a large unit not only provides advance assurance of satisfactory performance but allows for alterations in time for incorporation into the prototype.

**Testing Procedures** The model should have complete geometric similarity to the prototype in all wetted parts between the intake and discharge sections of the pump. The model should be tested in the same horizontal- or vertical-shaft position as the prototype. The speed of the model should be such that, at the test head, the specific speed for each test run is the same as that of the installed unit or prototype. Unless otherwise specified, the suction head or suction lift should give the same (cavitation factor) value.

If model and prototype diameters are  $D_1$  and  $D$ , respectively, then the model speed  $N_1$  and capacity  $Q_1$  under the test head  $H_1$  must agree with the relations

$$\frac{N_1}{N} = \frac{D}{D_1} \sqrt{\frac{H_1}{H}} \quad \text{and} \quad \frac{Q_1}{Q} = \left(\frac{D_1}{D}\right)^2 \sqrt{\frac{H_1}{H}}$$

In testing a model of reduced size under the previous conditions, complete hydraulic similarity will not be secured unless the relative roughness of the impeller and pump casing surfaces are the same. With the same surface texture in model and prototype, the model efficiency will be lower than that of the prototype, and greater relative clearances and shaft friction in the model will also reduce its efficiency.

The efficiency of a pump model can conveniently be stepped up to match the prototype efficiency by applying a formula of the same general form as the Moody formula used for hydraulic turbines:

$$\frac{1 - e_1}{1 - e} = \left(\frac{D}{D_1}\right)^n$$

The exponent  $n$  should be determined for a given laboratory and given type of pump on the basis of an adequate number of comparisons of the efficiencies of models and prototypes, with consistent surface finish in model and prototype. The *Hydraulic Institute Stan-*



*dards*<sup>2</sup> states that  $n$  has been found to vary from zero (when the surface roughness and clearances of the model and prototype are proportional to their size) to 0.26 (when the absolute roughness is the same in both).

When model tests are to serve as acceptance tests, it is generally recommended that the efficiency guarantees be stated in terms of model performance rather than in terms of calculated prototype performance. In the absence of such a provision, the efficiency stepup formula and the numerical value of its exponent should be clearly specified or agreed upon in advance of tests.

The Hydraulic Institute ANSI/HI 2000 Edition Pump Standards (Reference 10) give an example of model testing as follows:

**EXAMPLE** A single-stage pump to deliver 200 ft<sup>3</sup>/s (5.66 m<sup>3</sup>/s) against a head of 400 ft (122 m) at 450 rpm and with a positive suction head, including velocity head, of 10 ft (3 m) has an impeller diameter of 6.8 ft (2.1m). The pump being too large for a shop or laboratory test, a model with an 18-in (0.46-m) impeller is to be tested at a reduced head at 320 ft (97.5 m). At what speed, capacity, and suction head should the test be run?

Applying the above relations:

$$\text{in USCS units } N_1 = N \frac{D}{D_1} \sqrt{\frac{H_1}{H}} = 450 \left( \frac{6.8}{1.5} \right) \sqrt{\frac{320}{400}} = 1825 \text{ rpm}$$

$$Q_1 = Q \left( \frac{D_1}{D} \right)^2 \sqrt{\frac{H_1}{H}} = 200 \left( \frac{1.5}{6.8} \right)^2 \sqrt{\frac{320}{400}} = 8.73 \text{ ft}^3/\text{s} = 3920 \text{ gpm}$$

$$\text{in SI units } N_1 = 450 \left( \frac{2.1}{0.46} \right)^2 \sqrt{\frac{97.5}{122}} = 1825 \text{ rpm}$$

$$Q_1 = 5.66 \left( \frac{0.46}{22.1} \right)^2 \sqrt{\frac{97.5}{122}} = 0.247 \text{ m}^3/\text{s}$$

To check these results, the specific speed of the prototype is

$$\text{in USCS units } N_s = N \frac{\sqrt{Q}}{H^{3/4}} = 450 \frac{\sqrt{200}}{400^{3/4}} = 71.2 \text{ in the ft}^3/\text{s system}$$

$$\text{in SI units } N_s = \frac{450 \sqrt{5.66}}{122^{3/4}} = 39 \text{ in the m}^3/\text{s system}$$

and that of the model is

$$\text{in USCS units } N_{s1} = 1.825 \frac{\sqrt{8.73}}{320^{3/4}} = 71.2 \text{ (or 1,510 in the gpm system)}$$

$$\text{in SI units } N_{s1} = 1825 \frac{\sqrt{0.247}}{97.5^{3/4}} = 29$$

The cavitation factor  $\sigma$  for the field installation, assuming a water temperature of 80°F (27°C) as a maximum probable value and  $H_b = 32.8$  ft (10 m) as in the first example, will be

$$\text{in USCS units } \sigma = \frac{H_b - H_s}{H} = \frac{32.8 - 10}{400} = 0.057$$

$$\text{in SI units } \sigma = \frac{10 - 3}{122} = 0.057$$

where  $H_b = h_{sa} - H_{upa}$  (absolute atmospheric pressure minus absolute vapor pressure)  
 $H_s$  = distance from datum to suction level

which should be the same in the test. With the water temperature approximately the same,

$$\sigma = \frac{H_b - H_{s1}}{H_1}$$

in USCS units  $H_{s1} = H_b - \sigma H = 32.8 - (0.057)(320) = 14.6 \text{ ft}$

in SI units  $H_{s1} = 10 - (0.057)(97.5) = 4.4 \text{ m}$

Hence the model should be tested with a positive suction head of 14.6 ft (4.4 m) to reproduce the field conditions.

Normally one of the requirements when using model tests as acceptance tests is to make sure true geometric similarity exists between model and installed prototype. True values of all required and specified dimension should be determined. The actual parts, areas, shape, clearances, and positions should be clearly understood by all parties. Also, the amount of permissible geometric deviation between prototype and model should be agreed to, in writing, before the test is begun.

## OTHER OBSERVATIONS

---

**Testing Noncentrifugal Pumps** The next largest class of pumps after centrifugal are displacement pumps. This classification includes reciprocating, rotary, screw, and other miscellaneous displacement pumps. Testing of these closely parallels the centrifugal procedures. Normally the capacities are smaller and the heads higher, but the objectives, methods, and measurements are all about the same. The Hydraulic Institute ANSI/HI 2000 Edition Pump Standards (References 11 and 12) thoroughly cover testing of rotary and reciprocating pumps.

The testing of pumps not falling into the two broad classifications of centrifugal and displacement is usually very special, and each case must be treated separately. The test procedures are normally spelled out in the specifications; otherwise an agreement between all parties must be made before testing is started. The testing of eduction or jet pumps falls under this special category of testing.

**Other Test Phenomena** When testing pumps, other phenomena of interest should also be checked and noted on the test record. The two phenomena normally reported on are vibration and noise. The acceptable limits of these plus instrumentation for measuring them are special and normally covered in the contract. If the pumps are to be installed in a special environment, this should also be taken into consideration during testing.

## REFERENCES

---

1. American Society of Mechanical Engineers. "Performance Test Codes, Centrifugal Pumps," PTC 8.2-1990, ASME, New York, www.asme.org.
2. Hydraulic Institute. "Standards for Centrifugal, Rotary and Reciprocating Pumps," 13th ed., 1975 (out of print).
3. American Society of Mechanical Engineers. "Fluid Meters: Their Theory and Application," 6th ed., ASME, New York, 1971.
4. Smith, H., Jr. "Hydraulics," Wiley, New York, 1884.
5. Francis, J. B. "Lowell Hydraulic Experiments," Van Nostrand, New York, 1883.
6. Shen, J. "A Preliminary Report on the Discharge Characteristics of Trapezoidal-Notch Thin-Plate Weirs," U.S. Geological Survey, 1959.

7. Parshall, R. L. "Improving the Distribution of Water to Farmers by Use of the Parshall Measuring Flume," Bulletin 488, Soil Conservation Service, U.S. Department of Agriculture, Washington, DC, 1945.
8. Parshall, R. L. "Measuring Water in Irrigation Channels with Parshall Flumes and Weirs," Bulletin 843, Soil Conservation Service, U.S. Department of Agriculture, Washington, DC, 1950.
9. "Water Measurement Manual." 2nd ed., Bureau of Reclamation, U.S. Department of Interior, Denver, CO, 1967.
10. American National Standards for Centrifugal Pump Tests, ANSI/HI 1.6-2000, Hydraulic Institute, Parsippany, NJ, [www.pumps.org](http://www.pumps.org).
11. American National Standards for Rotary Pump Tests, ANSI/HI 3.6-2000, Hydraulic Institute, Parsippany, NJ, [www.pumps.org](http://www.pumps.org).
12. American National Standards for Reciprocating Pump Tests, ANSI/HI 6.6-2000, Hydraulic Institute, Parsippany, NJ, [www.pumps.org](http://www.pumps.org).
13. Hydraulic Institute ANSI/HI 2000 Edition Pump Standards, Hydraulic Institute, Parsippany, NJ, [www.pumps.org](http://www.pumps.org).

# TECHNICAL DATA

<b>Table 1A</b>	Base Units of the International System of Units (SI) and Their Definitions	A.2
<b>Table 1B</b>	Supplementary SI Units and Their Definitions	A.2
<b>Table 2</b>	Derived Units of the SI System	A.3
<b>Table 3</b>	Prefixes of SI Multiple and Submultiple Units	A.3
<b>Table 4</b>	Velocity and Frictional Head Loss in Old Cast Iron Piping Based on Hazen-Williams $C = 100$	A.4
<b>Figure 1</b>	Change in Hazen-Williams Coefficient $C$ with Years of Service for Cast Iron Pipes Handling Soft, Clear, Unfiltered Water	A.6
<b>Figure 2</b>	Atmospheric Pressures for Altitudes up to 12,000 ft (3600 m)	A.7
<b>Table 5</b>	Velocity and Frictional Head Loss in New Schedule 40 (Standard Weight) Steel Piping Based on Darcy-Weisbach	A.8
<b>Table 6</b>	Viscosity of Common Liquids	A.10
<b>Table 7</b>	Viscosity Conversion Tables	A.20
<b>Table 8</b>	Properties of Water at Temperatures from 40 to 705.4°F (4.4 to 374.1°C)	A.22
<b>Table 9</b>	Conversions of USCS to SI Units	A.25

**TABLE 1A** Base units of the International System of Units (SI) and their definitions

Symbol	Unit	Definition
m	meter <sup>a</sup>	Unit of length equal to 1,650,763.73 wavelengths in vacuum of the radiation corresponding to the transition between the $2p^{10}$ and $5d^5$ levels of the krypton-86 atom
kg	kilogram	Unit of mass equal to that of the international prototype of the kilogram
s	second	Unit of time equal to the duration of 9,192,631,770 periods of the radiation corresponding to the transition between two hyperfine levels of the ground state of the cesium-133 atom
A	ampere	Unit of electric current equal to that which, if maintained in two straight parallel conductors of infinite length and negligible cross-section and placed 1 meter (m) apart in vacuum, produces between those conductors a force equal to $2 \times 10^{-7}$ newtons per meter (N/m) of length
K	kelvin	Unit of thermodynamic temperature equal to the fraction 1/273.16 of the thermodynamic temperature of the triple point of water
cd	candela	Unit of luminous intensity equal to that (in the perpendicular direction) of a surface of 1/600,000 m <sup>2</sup> of a blackbody at the temperature of freezing platinum under a pressure of 101,325 newtons per square meter (N/m <sup>2</sup> )
mol	mole	Unit of substance equal to the amount of substance of a system that contains as many elementary entities <sup>b</sup> as there are atoms in 0.012 kg of carbon-12

<sup>a</sup>Spelled *metre* in countries other than the United States.

<sup>b</sup>When the mole is used, the elementary entities must be specified and may be atoms, molecules, ions, electrons, other particles, or specified groups of each particles.

**TABLE 1B** Supplementary SI units

Symbol	Unit	Definition
rad	radian	Unit of measure of a planar angle with its vertex at the center of a circle subtended by an arc equal in length to the radius
sr	steradian	Unit of measure of a solid angle with its vertex at the center of a sphere and enclosing an area of the spherical surface equal to that of a square with sides equal in length to the radius

**TABLE 2** Derived units of the SI system

Quantity	Unit	Symbol	Formula
Acceleration	meters per second per second	$\text{m/s}^2$	—
Angular acceleration	radians per second per second	$\text{rad/s}^2$	—
Angular velocity	radians per second	$\text{rad/s}$	—
Area	square meters	$\text{m}^2$	—
Density	kilograms per cubic meter	$\text{kg/m}^3$	—
Energy	joules	J	$\text{N} \cdot \text{m}$
Force	newtons	N	$\text{kg} \cdot \text{m/s}^2$
Frequency	hertz	Hz	cycle/s
Power	watts	W	J/s
Pressure	pascals	Pa	$\text{N/m}^2$
Stress	newtons per square meter	$\text{N/m}^2$	—
Velocity	meters per second	$\text{m/s}$	—
Viscosity, dynamic	newton-seconds per square meter	$\text{N} \cdot \text{s/m}^2$	—
Viscosity, kinematic	square meters per second	$\text{m}^2/\text{s}$	—
Volume	cubic meters	$\text{m}^3$	—
Work	joules	J	$\text{N} \cdot \text{m}$

**TABLE 3** Prefixes for SI multiple and submultiple units

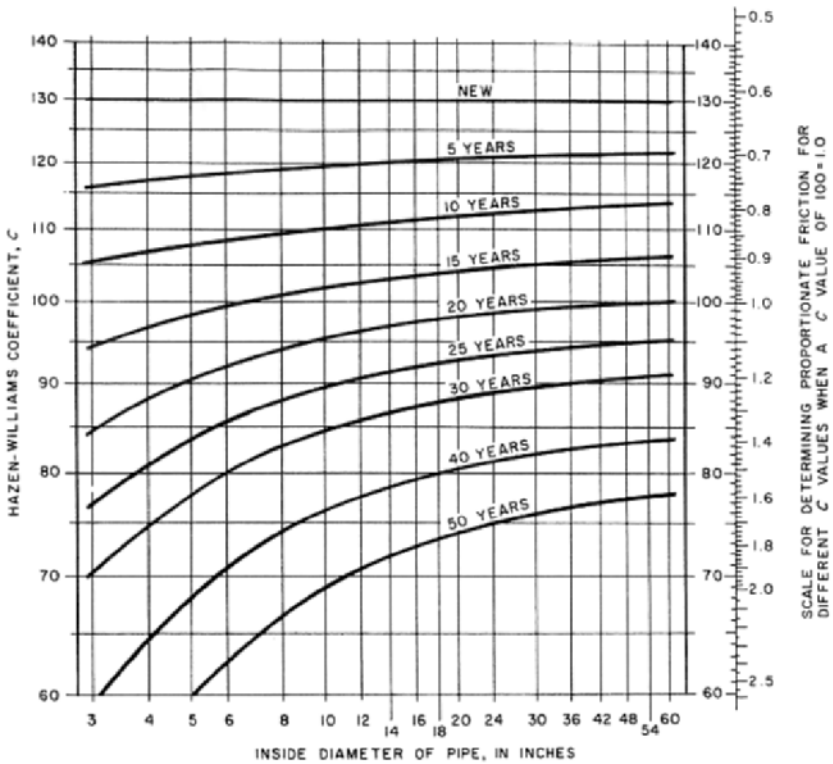
Prefix	SI symbol	Multiplication factor
exa	E	$10^{18}$
peta	P	$10^{15}$
tera	T	$10^{12}$
giga	G	$10^9$
mega	M	$10^6$
kilo	k	$10^3$
hecto	h	$10^2$
deka	da	10
deci	d	$10^{-1}$
centi	c	$10^{-2}$
milli	m	$10^{-3}$
micro	$\mu$	$10^{-6}$
nano	n	$10^{-9}$
pico	p	$10^{-12}$
femto	f	$10^{-15}$
atto	a	$10^{-18}$

**TABLE 4** Velocity and frictional head loss in old cast iron piping based on Hazen-Williams  $C = 100$ 

	$gpm^a$	$v^b$	$f^c$	$v$	$f$	$v$	$f$	$v$	$f$	$v$	$f$	$v$	$f$	$v$	$f$	$v$	$f$	$v$	$f$	$v$	$f$	$v$	$f$	gpm			
								3-in ID pipe <sup>d</sup>		4-in ID pipe																	
	30							1.36	0.534	0.77	0.131	5-in ID pipe													30		
	40							1.81	0.910	1.02	0.224															40	
	50							2.27	1.38	1.28	0.338	0.82	0.114	6-in ID pipe												50	
	60							2.72	1.92	1.53	0.475	0.98	0.160													60	
	70							3.18	2.56	1.79	0.631	1.14	0.213	0.79	0.088											70	
	80							3.63	3.28	2.04	0.808	1.31	0.273	0.91	0.112											80	
	90							4.08	4.08	2.30	1.01	1.47	0.339	1.02	0.139											90	
	100							4.54	4.96	2.55	1.22	1.63	0.412	1.14	0.170	8-in ID pipe										100	
	125							5.68	7.50	3.19	1.85	2.04	0.623	1.42	0.256											125	
	150							6.81	10.5	3.83	2.59	2.47	0.874	1.70	0.360	0.96	0.89									150	
	175							7.95	14.0	4.47	3.44	2.86	1.16	1.99	0.478	1.12	0.118									175	
	200							9.08	17.9	5.10	4.41	3.27	1.49	2.27	0.613	1.28	0.151	10-in ID pipe									200
	225							10.2	22.3	5.74	5.48	3.68	1.85	2.55	0.762	1.44	0.188									225	
	250							11.3	27.1	6.38	6.67	4.08	2.25	2.84	0.926	1.60	0.228	1.02	0.077							250	
	275							12.5	32.3	7.02	7.96	4.50	2.68	3.12	1.11	1.76	0.272	1.12	0.092							275	
		12-in ID pipe																									
	300							13.6	37.9	7.65	9.34	4.90	3.13	3.41	1.30	1.91	0.320	1.23	0.108							300	
	350	0.99	0.059	14-in ID pipe				15.9	50.4	8.93	12.4	5.72	4.20	3.97	1.73	2.23	0.425	1.43	0.144								350
	400	1.13	0.076					18.2	64.6	10.2	15.9	6.54	5.38	4.54	2.21	2.55	0.545	1.63	0.184							400	
	450	1.28	0.094	0.94	0.044					11.5	19.8	7.36	6.68	5.10	2.75	2.87	0.678	1.84	0.228							450	
	500	1.42	0.114	1.04	0.054				12.8	24.1	8.18	8.12	5.68	3.34	3.19	0.823	2.04	0.278								500	
						16-in ID pipe																					
	550	1.56	0.136	1.15	0.064					14.0	28.7	8.99	9.69	6.24	3.99	3.51	0.982	2.24	0.331							550	
	600	1.70	0.160	1.25	0.076	0.96	0.039			15.3	33.7	9.81	11.4	6.81	4.68	3.82	1.15	2.45	0.389							600	
	650	1.84	0.186	1.36	0.088	1.04	0.046	18-in ID pipe		16.6	39.1	10.6	13.2	7.38	5.43	4.15	1.34	2.65	0.452							650	
	700	1.99	0.214	1.46	0.100	1.12	0.052			17.9	44.9	11.4	15.1	7.94	6.23	4.47	1.53	2.86	0.518							700	
	750	2.13	0.242	1.56	0.114	1.20	0.060	0.95	0.034			12.3	17.2	8.51	7.08	4.78	1.74	3.06	0.589							750	
	800	2.27	0.273	1.67	0.129	1.28	0.067	1.01	0.038	20-in ID pipe		13.1	19.4	9.08	7.98	5.10	1.97	3.26	0.666							800	
	900	2.55	0.339	1.88	0.160	1.44	0.084	1.13	0.047			14.7	24.1	10.2	9.92	5.74	2.44	3.67	0.825							900	
	1,000	2.83	0.412	2.08	0.195	1.60	0.102	1.26	0.057	1.02	0.034	16.3	29.3	11.4	12.1	6.38	2.97	4.08	1.00							1,000	
	1,100	3.12	0.492	2.29	0.232	1.76	0.121	1.39	0.068	1.12	0.041	18.0	35.0	12.5	14.4	7.02	3.55	4.50	1.20							1,100	
	1,200	3.40	0.578	2.50	0.273	1.92	0.143	1.51	0.080	1.23	0.048			13.6	16.9	7.66	4.17	4.90	1.41							1,200	







**FIGURE 1** Change in Hazen-Williams coefficient  $C$  with years of service, for cast iron pipes handling soft, clear, unfiltered water at 60°F (15.6°C). To correct head loss from Table 4, which is based on  $C = 100$ , multiply by the conversion factor. For example, with a flow of 700 gpm through a 6-in pipe, the frictional head loss is 6.23 ft per 100 ft of pipe with  $C = 100$ . For  $C = 130$ , the conversion factor is 0.613; therefore, the frictional head loss is  $6.23 \times 0.613 = 3.82$  ft per 100 ft of pipe (see also Section 8.1) (1 in = 25.4 mm).

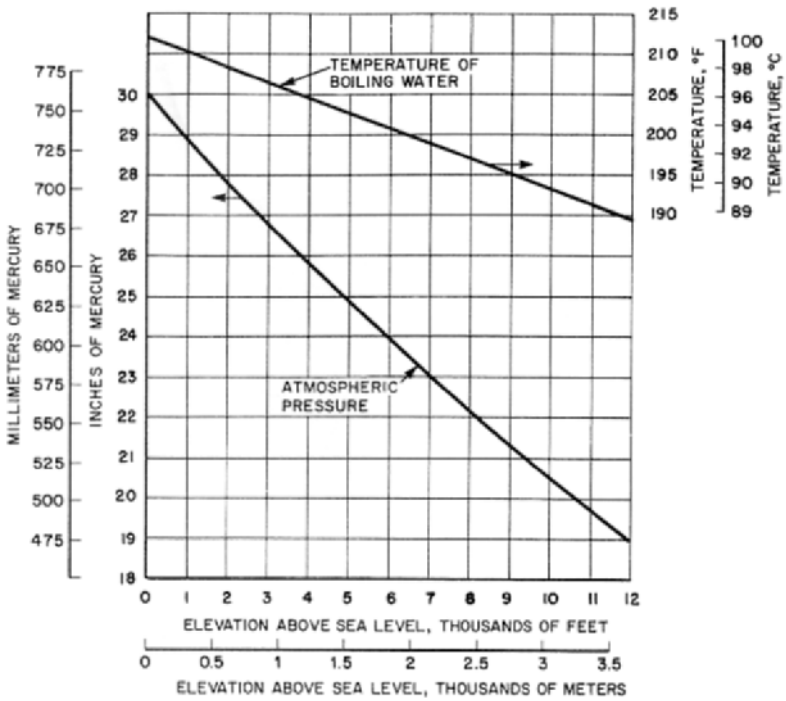


FIGURE 2 Atmospheric pressures for altitudes up to 12,000 ft (3600 m)

**TABLE 5** Velocity and frictional head loss in new schedule 40 (standard weight) steel piping based on Darcy-Weisbach

		$gpm^a$	$v^b$	$f^c$	$v$	$f$	$v$	$f$	$v$	$f$	$v$	$f$	$v$	$f$	$v$	$f$	$v$	$f$	$v$	$f$	gpm	
<b>A 8</b>					1-in pipe <sup>d</sup> (1.049-in ID)		1¼-in pipe (1.380-in ID)		1½-in pipe (1.610-in ID)		2-in pipe (2.067-in ID)		2½-in pipe (2.469-in ID)		3-in pipe (3.068-in ID)							
	1				0.37	0.11																1
	2				0.74	0.39	0.43	0.10														2
	3				1.11	0.82	0.64	0.21	0.47	0.10												3
	4				1.49	1.37	0.86	0.36	0.63	0.17												4
	5				1.86	2.08	1.07	0.54	0.79	0.26												5
	6				2.23	2.83	1.28	0.76	0.95	0.35	0.57	0.10										6
	8				2.97	4.88	1.72	1.29	1.26	0.61	0.76	0.17										8
	10				3.71	7.12	2.14	1.95	1.57	0.90	0.96	0.26	0.67	0.11								10
	15	3 ½-in pipe (3.548-in ID)				5.56	15.0	3.21	4.06	2.36	1.87	1.43	0.54	1.00	0.23							15
	20				7.41	25.6	4.28	6.80	3.15	3.12	1.91	0.92	1.34	0.38	0.87	0.13						20
				4-in pipe (4.026-in ID)				5.35	10.3	3.94	4.70	2.38	1.39	1.67	0.58	1.08	0.20					25
	25	0.81	0.10					6.43	14.4	4.72	6.60	2.86	1.92	2.00	0.81	1.30	0.28					30
	30	0.97	0.13							6.30	11.2	3.82	3.35	2.68	1.36	1.73	0.47					40
	40	1.30	0.23	1.01	0.12					7.87	16.6	4.77	5.00	3.34	2.06	2.16	0.72					50
	50	1.62	0.34	1.26	0.18	5-in pipe (5.047-in ID)				5.72	7.00	4.02	2.85	2.60	0.99	2.60	0.99					60
	60	1.94	0.48	1.51	0.25																	60
	70	2.27	0.63	1.76	0.34	1.12	0.11	6-in pipe (6.065-in ID)						6.68	9.40	4.68	3.80	3.03	1.33			70
	80	2.59	0.82	2.01	0.43	1.28	0.15							7.62	11.9	5.35	4.95	3.46	1.72			80
	90	2.91	1.00	2.27	0.54	1.44	0.18							8.60	14.7	6.02	6.05	3.89	2.13			90
100	3.24	1.24	2.52	0.65	1.60	0.22	1.11	0.09					9.56	18.7	6.70	7.47	4.83	2.58			100	
125	4.05	1.82	3.15	1.00	2.00	0.33	1.39	0.13							8.37	11.1	5.41	3.90			125	
150	4.86	2.55	3.78	1.39	2.40	0.47	1.66	0.18	8-in pipe (7.981-in ID)				10.0	15.4	6.50	5.44					150	
175	5.66	3.40	4.40	1.90	2.80	0.62	1.94	0.24					11.7	20.8	7.58	7.30					175	
200	6.48	4.35	5.04	2.40	3.20	0.80	2.22	0.31							8.66	9.18					200	
225	7.30	5.44	5.66	2.98	3.60	0.97	2.50	0.38	1.44	0.10					9.75	11.6					225	
250	8.10	6.59	6.29	3.68	4.00	1.19	2.77	0.47	1.60	0.12							10.8	14.0			250	

**TABLE 5** Continued.

<i>gpm</i> <sup>a</sup>	<i>v</i> <sup>b</sup>	<i>f</i> <sup>c</sup>	<i>v</i>	<i>f</i>	<i>v</i>	<i>f</i>	<i>v</i>	<i>f</i>	<i>v</i>	<i>f</i>	<i>v</i>	<i>f</i>	<i>v</i>	<i>f</i>	<i>v</i>	<i>f</i>	<i>gpm</i>			
275	8.91	7.90	6.92	4.35	4.40	1.43	3.05	0.56	1.76	0.15	10-in pipe					11.9	16.9	275		
300	9.72	9.30	7.55	5.04	4.80	1.65	3.32	0.66	1.92	0.17	(10.020-in ID)					13.0	19.6	300		
350	11.3	12.2	8.80	6.85	5.60	2.21	3.88	0.88	2.24	0.23								350		
400	13.0	15.9	10.1	8.67	6.40	2.89	4.44	1.12	2.56	0.29	1.62	0.10								400
450	14.6	20.0	11.3	10.9	7.20	3.56	4.99	1.40	2.88	0.37	1.82	0.12								450
500			12.6	13.3	8.00	4.36	5.54	1.72	3.20	0.45	2.03	0.15								500
550			13.9	16.0	8.80	5.17	6.10	2.06	3.52	0.55	2.23	0.18								550
600			15.1	19.1	9.60	6.16	6.65	2.42	3.84	0.63	2.44	0.21								600
650					10.4	7.22	7.20	2.78	4.16	0.73	2.64	0.24								650
700					11.2	8.29	7.75	3.25	4.47	0.85	2.84	0.28								700
750					12.0	9.40	8.31	3.63	4.80	0.97	3.04	0.31								750
800					12.8	10.3	8.87	4.11	5.11	1.11	3.25	0.35								800
900					14.4	13.0	9.96	5.12	5.75	1.33	3.65	0.44								900
1,000					16.0	15.8	11.1	6.17	6.40	1.64	4.06	0.55								1,000
1,100					17.6	19.0	12.2	7.45	7.04	1.98	4.46	0.64								1,100
1,200							13.3	8.73	7.67	2.36	4.87	0.75								1,200
1,300							14.4	10.2	8.31	2.71	5.27	0.88								1,300
1,400							15.5	11.9	8.95	3.10	5.68	1.02								1,400
1,500							16.7	13.2	9.60	3.49	6.09	1.18								1,500
1,600							17.8	15.0	10.2	3.92	6.49	1.31								1,600
1,800							20.0	18.5	11.5	4.99	7.30	1.60								1,800
2,000									12.8	5.96	8.11	1.97								2,000
2,500									16.0	9.00	10.2	2.95								2,500
3,000									19.2	12.5	12.2	4.15								3,000
3,500									22.4	16.6	14.2	5.60								3,500
4,000											16.2	6.90								4,000
4,500											18.3	8.80								4,500
5,000											20.3	10.8								5,000
5,500											22.3	13.0								5,500
6,000											24.4	15.3								6,000

<sup>a</sup>1 gpm = 6.31 × 10<sup>-5</sup> m<sup>3</sup>/s = 0.227 m<sup>3</sup>/h = 0.0631 liters/s

<sup>b</sup>Velocity, in feet per second. 1 ft/s = 0.305 m/s

<sup>c</sup>Frictional head loss, in feet of water per 100 feet of pipe. 1 ft = 0.305 m. Friction values apply to pipe carrying water at 60°F (15.6°C).

<sup>d</sup>1 in = 25.4 mm

**TABLE 6** Viscosity of common liquids

Typical SSU values as standardized by reputable authorities are shown in boldface type.

Liquid	Sp. gr. at 60°F (15.6°C) <sup>a</sup>	Viscosity			
		SSU	Centistokes	At °F	At °C
Freon	1.37 to 1.49 @ 70°F (21°C)		0.27-0.32	70	21
Glycerine (100%)	1.26 @ 68°F (20°C)	2950 813	648 176	68.6 100	20.3 38
Glycol					
Propylene	1.038 @ 68°F (20°C)	240.6	52	70	21
Triethylene	1.125 @ 68°F (20°C)	185.7	40	70	21
Diethylene	1.12	149.7	32	70	21
Ethylene	1.125	88.4	17.8	70	21
Hydrochloric acid (31.5%)	1.05 @ 68°F (20°C)		1.9	68	20
Mercury	13.6		0.118 0.11	70 100	21 38
Phenol (carbolic acid)	0.95 to 1.08	65	11.7	65	18
Silicate of soda	40 Baumé	365	79	100	38
	42 Baumé	637.6	138	100	38
Sulfuric acid (100%)	1.83	75.7	14.6	68	20
Fish and animal oils					
Bone oil	0.918	220 <b>65</b>	47.5 11.6	130 212	54 100
Cod oil	0.928	<b>150</b> 95	32.1 19.4	100 130	38 54
Lard	0.96	<b>287</b> 160	62.1 34.3	100 130	38 54
Lard oil	0.912 to 0.925	<b>190 to 220</b> 112 to 128	41 to 47.5 23.4 to 27.1	100 130	38 54

**TABLE 6** Continued.

Fish and animal oils						
Liquid	Sp. gr. at 60°F (15.6°C) <sup>a</sup>	SSU	Centistokes	At °F	At °C	
Menhaden oil	0.933	<b>140</b>	29.8	100	38	
		90	18.2	130	54	
Neatsfoot oil	0.917	<b>230</b>	49.7	100	38	
		130	27.5	130	54	
Sperm oil	0.883	<b>110</b>	23.0	100	38	
		78	15.2	130	54	
Whale oil	0.925	<b>163 to 184</b>	35 to 39.6	100	38	
		97 to 112	19.9 to 23.4	130	54	
Mineral oils						
A.11	Automobile crankcase oils (average mid-continent paraffin base):					
	SAE 10	0.880 to 0.935 <sup>b</sup>	165 to 240	35.4 to 51.9	100	38
			<b>90 to 120</b>	18.2 to 25.3	130	54
	SAE 20	0.880 to 0.935 <sup>b</sup>	240 to 400	51.9 to 86.6	100	38
			<b>120 to 185</b>	25.3 to 39.9	100	54
	SAE 30	0.880 to 0.935 <sup>b</sup>	400 to 580	86.6 to 125.5	100	38
			<b>185 to 255</b>	39.9 to 55.1	130	54
	SAE 40	0.880 to 0.935 <sup>b</sup>	580 to 950	125.5 to 205.6	100	38
			<b>255 to</b>	55.1 to	130	54
			<b>80</b>	15.6	210	99
	SAE 50	0.880 to 0.935 <sup>b</sup>	950 to 1600	205.6 to 352	100	38
			<b>80 to 105</b>	15.6 to 21.6	210	99
	SAE 60	0.880 to 0.935 <sup>b</sup>	1600 to 2300	352 to 507	100	38
			<b>105 to 125</b>	21.6 to 26.2	210	99
	SAE 70	0.880 to 0.935 <sup>b</sup>	2300 to 3100	507 to 682	100	38
		<b>125 to 150</b>	26.2 to 31.8	210	99	
SAE 10W	0.880 to 0.935 <sup>b</sup>	<b>5000 to 10,000</b>	1100 to 2200	0	-18	
SAE 20W	0.880 to 0.935 <sup>b</sup>	<b>10,000 to 40,000</b>	2200 to 8800	0	-18	

**TABLE 6** Continued.

Mineral oils					
Liquid	Sp. gr. at 60°F (15.6°C) <sup>a</sup>	SSU	Centistokes	At °F	At °C
Automobile transmission lubricants					
SAE 80	0.880 to 0.935 <sup>b</sup>	<b>100,000</b> max	22,000 max	0	-18
SAE 90	0.880 to 0.935 <sup>b</sup>	<b>800 to 1500</b>	173.2 to 324.7	100	38
		300 to 500	64.5 to 108.2	130	54
SAE 140	0.880 to 0.935 <sup>b</sup>	950 to 2300	205.6 to 507	130	54
		<b>120 to 200</b>	25.1 to 42.9	210	99
SAE 250	0.880 to 0.935 <sup>b</sup>	Over 2300	Over 507	130	54
		Over 200	Over 42.9	210	99
Crude oils					
Texas, Oklahoma	0.81 to 0.916	40 to 783	4.28 to 169.5	60	16
		34.2 to 210	2.45 to 45.3	100	38
Wyoming, Montana	0.86 to 0.88	74 to 1215	14.1 to 263	60	16
		46 to 320	6.16 to 69.3	100	38
California	0.78 to 0.92	40 to 4840	4.28 to 1063	60	16
		34 to 700	2.4 to 151.5	100	38
Pennsylvania	0.8 to 0.85	46 to 216	6.16 to 46.7	60	16
		38 to 86	3.64 to 17.2	100	38
Diesel engine lubricating oils (based on average mid-continent paraffin base)					
Federal specification no. 9110	0.880 to 0.935 <sup>b</sup>	165 to 240	35.4 to 51.9	100	38
		<b>90 to 120</b>	18.2 to 25.3	130	54
Federal specification no. 9170	0.880 to 0.935 <sup>b</sup>	300 to 410	64.5 to 88.8	100	38
		<b>140 to 180</b>	29.8 to 38.8	130	54
Federal specification no. 9250	0.880 to 0.935 <sup>b</sup>	470 to 590	101.8 to 127.8	100	38
		<b>200 to 255</b>	43.2 to 55.1	130	54
Federal specification no. 9370	0.880 to 0.935 <sup>b</sup>	800 to 1100	173.2 to 238.1	100	38
		<b>320 to 430</b>	69.3 to 93.1	130	54

**TABLE 6** Continued.

Mineral oils					
Liquid	Sp. gr. at 60°F (15.6°C) <sup>a</sup>	SSU	Centistokes	At °F	At °C
Federal specification no. 9500	0.880 to 0.935 <sup>b</sup>	490 to 600 <b>92 to 105</b>	106.1 to 129.9 18.54 to 21.6	130 210	54 99
Diesel fuel oils					
No. 2 D	0.82 to 0.95 <sup>b</sup>	32.6 to 45.5 39	2 to 6 1 to 3.97	100 130	38 54
No. 3 D	0.82 to 0.95 <sup>b</sup>	<b>45.5 to 65</b> 39 to 48	6 to 11.75 3.97 to 6.78	100 130	38 54
No. 4 D	0.82 to 0.95 <sup>b</sup>	<b>140 max</b> 70 max	29.8 max 13.1 max	100 130	38 54
No. 5 D	0.82 to 0.95 <sup>b</sup>	<b>400 max</b> 165 max	86.6 max 35.2 max	122 160	50 71
Fuel oils					
No. 1	0.82 to 0.95 <sup>b</sup>	34 to 40 <b>32 to 35</b>	2.39 to 4.28 2.69	70 100	21 38
No. 2	0.82 to 0.95 <sup>b</sup>	36 to 50 <b>33 to 40</b>	3.0 to 7.4 2.11 to 4.28	70 100	21 38
No. 3	0.82 to 0.95 <sup>b</sup>	<b>35 to 45</b> 32.8 to 39	2.69 to 0.584 2.06 to 3.97	100 130	38 54
No. 5A	0.82 to 0.95 <sup>b</sup>	<b>50 to 125</b> 42 to 72	7.4 to 26.4 4.91 to 13.73	100 130	38 54
No. 5B	0.82 to 0.95 <sup>b</sup>	125 to <b>400</b> 72 to 310	26.4 to 86.6 13.63 to 67.1	100 122 130	38 50 54
No. 6	0.82 to 0.95 <sup>b</sup>	<b>450 to 3000</b> 175 to 780	97.4 to 660 37.5 to 172	122 160	50 71

A.13



**TABLE 6** Continued.

Mineral oils					
Liquid	Sp. gr. at 60°F (15.6°C) <sup>a</sup>	SSU	Centistokes	At °F	At °C
Fuel oil, navy specification	0.989 max <sup>b</sup>	<b>110</b> to <b>225</b> 63 to 115	23 to 48.6 11.08 to 23.9	122 160	50 71
Fuel oil, navy II	1.0 max	<b>1500</b> max 480 max	324.7 max 104 max	122 60	50 71
Gasoline	0.68 to 0.74		0.46 to 0.88 0.40 to 0.71	60 100	16 38
Gasoline (natural)	76.5 degrees API		0.41	68	20
Gas oil	28 degrees API	73 50	13.9 7.4	70 100	21 38
Insulating oil					
Transformer, switches, and circuit breakers		115 max <b>65</b> max	24.1 max 11.75 max	70 100	21 38
Kerosene	0.78 to 0.82	35 32.6	2.69 2	68 100	20 38
Machine lubricating oil (average Pennsylvania paraffin base)					
Federal specification no. 8	0.880 to 0.935 <sup>b</sup>	112 to 160 <b>70</b> to <b>90</b>	23.4 to 34.3 13.1 to 18.2	100 130	38 54
Federal specification no. 10	0.880 to 0.935 <sup>b</sup>	160 to 235 <b>90</b> to <b>120</b>	34.3 to 50.8 18.2 to 25.3	100 130	38 54
Federal specification no. 20	0.880 to 0.935 <sup>b</sup>	235 to 385 <b>120</b> to <b>185</b>	50.8 to 83.4 25.3 to 39.9	100 130	38 54
Federal specification no. 30	0.880 to 0.935 <sup>b</sup>	385 to 550 185 to 255	83.4 to 119 39.9 to 55.1	100 130	38 54

**TABLE 6** Continued.

Mineral oils					
Liquid	Sp. gr. at 60°F (15.6°C) <sup>a</sup>	SSU	Centistokes	At °F	At °C
Mineral lard cutting oil					
Federal specification grade 1		<b>140 to 190</b>	29.8 to 41	100	38
		86 to 110	17.22 to 23	130	54
Federal specification grade 2		<b>190 to 220</b>	41 to 47.5	100	38
		110 to 125	23 to 26.4	130	54
Petrolatum	0.825	100	20.6	130	54
		77	14.8	160	71
Turbine lubricating oil					
Federal specification (penn base)	0.91 average	400 to 440	86.6 to 95.2	100	38
		<b>185 to 205</b>	39.9 to 44.3	130	54
Vegetable oils					
Castor oil	0.96 @ 68°F (20°C)	1200 to 1500	259.8 to 324.7	100	38
		<b>450 to 600</b>	97.4 to 129.9	130	54
China wood oil	0.943	<b>1425</b>	308.5	69	21
		580	125.5	100	38
Coconut oil	0.925	<b>140 to 148</b>	29.8 to 31.6	100	38
		76 to 80	14.69 to 15.7	130	54
Corn oil	0.924	135	28.7	130	54
		<b>54</b>	8.59	212	100
Cotton seed oil	0.98 to 0.925	<b>176</b>	37.9	100	38
		100	20.6	130	54
Linseed oil, raw	0.925 to 0.939	<b>143</b>	30.5	100	38
		93	18.94	130	54
Olive oil	0.912 to 0.918	<b>200</b>	43.2	100	38
		115	24.1	130	54

**TABLE 6** Continued.

Vegetable oils					
Liquid	Sp. gr. at 60°F (15.6°C) <sup>a</sup>	SSU	Centistokes	At °F	At °C
Palm oil	0.924	<b>221</b>	47.8	100	38
		125	26.4	130	54
Peanut Oil	0.920	<b>221</b>	47.8	100	38
		125	26.4	130	54
Rape seed oil	0.919	<b>250</b>	54.1	100	38
		145	31	130	54
Rosin oil	0.980	<b>1500</b>	324.7	100	38
		600	129.9	130	54
Rosin (wood)	1.09 avg.	500 to <b>20,000</b>	108.2 to 4,400	200	93
		1,000 to 50,000	216.4 to 11,000	190	88
Sesame oil	0.923	<b>184</b>	39.6	100	38
		110	23	130	54
Soybean oil	0.927 to 0.98	<b>165</b>	35.4	100	38
		96	19.64	130	54
Turpentine	0.86 to 0.87	33	2.11	60	16
		32.6	2.0	100	38
Sugar, syrups, molasses, and so on					
Corn syrups	1.4 to 1.47	5,000 to 500,000	1,100 to 110,000	100	38
		1,500 to 60,000	324.7 to 13,200	130	54
Glucose	1.35 to 1.44	35,000 to 100,000	7,700 to 22,000	100	38
		4,000 to 11,000	880 to 2,420	150	66
Honey (raw)		340	73.6	100	38
Molasses "A" (first)	1.40 to 1.46	1,300 to 23,000	281.1 to 5,070	100	38
		700 to 8,000	151.5 to 1,760	130	54
Molasses "B" (second)	1.43 to 1.48	6,400 to 60,000	1,410 to 13,200	100	38
		3,000 to 15,000	660 to 3,300	130	54
Molasses "C" (blackstrap or final)	1.46 to 1.49	17,000 to 250,000	2,630 to 5,500	100	38
		6,000 to 75,000	1,320 to 16,500	130	54

**TABLE 6** Continued.

Sugar, syrup, molasses, and so on					
Liquid	Sp. gr. at 60°F (15.6°C) <sup>a</sup>	SSU	Centistokes	At °F	At °C
Sucrose solutions (sugar syrups)					
60 Brix	1.29	230	49.7	70	21
		92	18.7	100	38
62 Brix	1.30	310	67.1	70	21
		111	23.2	100	38
64 Brix	1.31	440	95.2	70	21
		148	31.6	100	38
66 Brix	1.326	650	140.7	70	21
		195	42.0	100	38
68 Brix	1.338	1,000	216.4	70	21
		275	59.5	100	38
70 Brix	1.35	1,650	364	70	21
		400	86.6	100	38
72 Brix	1.36	2,700	595	70	21
		640	138.6	100	38
74 Brix	1.376	5,500	1,210	70	21
		1,100	238	100	38
76 Brix	1.39	10,000	2,200	70	21
		2,000	440	100	38
Tars					
Tar, coke oven	1.12+	<b>3,000 to 8,000</b>	600 to 1,760	71	21
		650 to 1,400	140.7 to 308	100	38
Tar, gas house	1.16 to 1.30	<b>15,000 to 300,000</b>	3,300 to 66,000	70	21
		2,000 to 20,000	440 to 4,400	100	38

**TABLE 6** Continued.

Tars					
Liquid	Sp. gr. at 60°F (15.6°C) <sup>a</sup>	SSU	Centistokes	At °F	At °C
Road tar					
Grade RT-2	1.07+	<b>200 to 300</b> 55 to 60	43.2 to 64.9 8.77 to 10.22	122 212	50 100
Grade RT-4	1.08+	<b>400 to 700</b> 65 to 75	86.6 to 154 11.63 to 14.28	122 212	50 100
Grade RT-6	1.09+	<b>1,000 to 2,000</b> 85 to 125	216.4 to 440 16.83 to 26.2	122 212	50 100
Grade RT-8	1.13+	<b>3,000 to 8,000</b> 150 to 225	660 to 1,760 31.8 to 48.3	122 212	50 100
Grade RT-10	1.14+	<b>20,000 to 60,000</b> 250 to 400	4,400 to 13,200 53.7 to 86.6	122 212	50 100
Grade RT-12	1.15+	114,000 to 456,000 <b>500 to 800</b>	25,000 to 75,000 108.2 to 173.2	122 212	50 100
Pine tar	1.06	2,500 500	559 108.2	100 132	38 56
Miscellaneous					
Corn starch solutions					
22 Baumé	1.18	150 130	32.1 27.5	70 100	21 38
24 Baumé	1.20	600 440	129.8 95.2	70 100	21 38
25 Baumé	1.21	1,400 800	303 173.2	70 100	21 38
Ink, printers	1.00 to 1.38	2,500 to 10,000 1,100 to 3,000	550 to 2,200 238.1 to 660	100 130	38 54
Tallow	0.918 avg.	56	9.07	212	100
Milk	1.02 to 1.05		1.13	68	20

**TABLE 6** Continued.

Liquid	Miscellaneous				
	Sp. gr. at 60°F (15.6°C) <sup>a</sup>	SSU	Centistokes	At °F	At °C
Varnish, spar	0.9	1425	313	68	20
		650	143	100	38
Water, fresh	1.0		1.123	60	16
			0.516	130	54

<sup>a</sup>Unless otherwise noted<sup>b</sup>Depends on origin or percent and type of solventSource: *Hydraulic Institute Engineering Data Book*, 2nd Edition, 1990, Hydraulic Institute, Parsippany, NJ

**TABLE 7** Viscosity Conversion Table

This table gives an approximate comparison of ratings so that, if a viscosity is given in terms other than Saybolt seconds universal, it can be translated quickly by following horizontally to the SSU column.

	Saybolt universal seconds SSU	Kinematic viscosity, cSt*	Approx. seconds, Mac Michael	Approx. Gardner Holt bubble	Seconds, Zahn cup 1	Seconds, Zahn cup 2	Seconds, Zahn cup 3	Seconds, Zahn cup 4	Seconds, Zahn cup 5	Seconds, Demmler cup 1	Seconds, Demmler cup 10	Approx. seconds, Stormer 100-g load	Seconds, Pratt and Lambert "F"
	31	1.00	—	—	—	—	—	—	—	—	—	—	—
	35	2.56	—	—	—	—	—	—	—	—	—	—	—
	40	4.30	—	—	—	—	—	—	—	1.3	—	—	—
	50	7.40	—	—	—	—	—	—	—	2.3	—	2.6	—
	60	10.3	—	—	—	—	—	—	—	3.2	—	3.6	—
	70	13.1	—	—	—	—	—	—	—	4.1	—	4.6	—
	80	15.7	—	—	—	—	—	—	—	4.9	—	5.5	—
	90	18.2	—	—	—	—	—	—	—	5.7	—	6.4	—
	100	20.6	125	—	38	18	—	—	—	6.5	—	7.3	—
	150	32.1	145	—	47	20	—	—	—	10.0	1.0	11.3	—
	200	43.2	165	A	54	23	—	—	—	13.5	1.4	15.2	—
	250	54.0	198	A	62	26	—	—	—	16.9	1.7	19	—
	300	65.0	225	B	73	29	—	—	—	20.4	2.0	23	—
	400	87.0	270	C	90	37	—	—	—	27.4	2.7	31	7
	500	110.0	320	D	—	46	—	—	—	34.5	3.5	39	8
	600	132	370	F	—	55	—	—	—	41	4.1	46	9
	700	154	420	G	—	63	22.5	—	—	48	4.8	54	9.5
	800	176	470	—	—	72	24.5	—	—	55	5.5	62	10.8
	900	198	515	H	—	80	27	18	—	62	6.2	70	11.9
	1000	220	570	I	—	88	29	20	138	69	6.9	77	12.4
	1500	330	805	M	—	—	40	28	18	103	10.3	116	16.8
	2000	440	1070	Q	—	—	51	34	24	137	13.7	154	22
	2500	550	1325	T	—	—	63	41	29	172	17.2	193	27.6
	3000	660	1690	U	—	—	75	48	33	206	20.6	232	33.7
	4000	880	2110	V	—	—	—	63	43	275	27.5	308	45
	5000	1100	2635	W	—	—	—	77	50	344	34.4	385	55.8
	6000	1320	3145	X	—	—	—	—	65	413	41.3	462	65.5

A.20

**TABLE 7** Continued.

Saybolt universal seconds SSU	Kinematic viscosity, cSt <sup>a</sup>	Approx. seconds, Mac Michael	Approx. Gardner Holt bubble	Seconds, Zahn cup 1	Seconds, Zahn cup 2	Seconds, Zahn cup 3	Seconds, Zahn cup 4	Seconds, Zahn cup 5	Seconds, Demmler cup 1	Seconds, Demmler cup 10	Approx. seconds, Stormer 100-g load	Seconds, Pratt and Lambert "F"
7000	1540	3670	—	—	—	—	—	75	481	48	540	77
8000	1760	4170	Y	—	—	—	—	86	550	55	618	89
9000	1980	4700	—	—	—	—	—	96	620	62	695	102
10,000	2200	5220	Z	—	—	—	—	—	690	69	770	113
15,000	3300	7720	Z2	—	—	—	—	—	1030	103	1160	172
20,000	4400	10500	Z3	—	—	—	—	—	1370	137	1540	234

$$^a\text{Kinematic viscosity (in centistokes)} = \frac{\text{absolute viscosity (in centipoises)}}{\text{density}}$$

When the SI units centistokes and centipoises are used, the density is numerically equal to the specific gravity. Therefore, the following will be sufficiently accurate for most calculations:

$$\text{Kinematic viscosity (in centistokes)} = \frac{\text{absolute viscosity (in centipoises)}}{\text{specific gravity}}$$

When USCS units are used, the density must be used rather than the specific gravity.

Note: For values of 70 cSt and above, use the conversion

$$\text{SSU} = \text{centistokes} \times 4.635$$

Above the range of this table and within the range of the viscosimeter, multiply the particular value by the following approximate factors to convert to SSU:

Viscosimeter	Factor
Mac Michael	1.92 (approx.)
Demmler 1	14.6
Demmler 10	146
Stormer	13 (approx.)

Source: *Hydraulic Institute Engineering Data Book*, 2nd Edition, 1990, Hydraulic Institute, Parsippany, NJ



**TABLE 7** Viscosity conversion table, (cont.)

This table gives an approximate comparison of ratings so that, if a viscosity is given in terms other than Saybolt seconds universal, it can be translated quickly by following horizontally to the SSU column.

Saybolt seconds universal SSU	Kinematic viscosity, cSt*	Saybolt seconds Furoil SSF	Seconds, Redwood 1 (standard)	Seconds, Redwood 2 (admiralty)	Degrees, Engler	Degrees, Barbey	Seconds, Parlin cup 7	Seconds, Parlin cup 10	Seconds, Parlin cup 15	Seconds, Parlin 20	Seconds, Ford cup 3	Seconds, Ford cup 4
31	1.00	—	29	—	1.00	6200	—	—	—	—	—	—
35	2.56	—	32.1	—	1.16	2420	—	—	—	—	—	—
40	4.30	—	36.2	5.10	1.31	1440	—	—	—	—	—	—
50	7.40	—	44.3	5.83	1.58	838	—	—	—	—	—	—
60	10.3	—	52.3	6.77	1.88	618	—	—	—	—	—	—
70	13.1	12.95	60.9	7.60	2.17	483	—	—	—	—	—	—
80	15.7	13.70	69.2	8.44	2.45	404	—	—	—	—	—	—
90	18.2	14.44	77.6	9.30	2.73	348	—	—	—	—	—	—
100	20.6	15.24	85.6	10.12	3.02	307	—	—	—	—	—	—
150	32.1	19.30	128	14.48	4.48	195	—	—	—	—	—	—
200	43.2	23.5	170	18.90	5.92	144	40	—	—	—	—	—
250	54.0	28.0	212	23.45	7.35	114	46	—	—	—	—	—
300	65.0	32.5	254	28.0	8.79	95	52.5	15	6.0	3.0	30	20
400	87.60	41.9	338	37.1	11.70	70.8	66	21	7.2	3.2	42	28
500	110.0	51.6	423	46.2	14.60	56.4	79	25	7.8	3.4	50	34
600	132	61.4	508	55.4	17.50	47.0	92	30	8.5	3.6	58	40
700	154	71.1	592	64.6	20.45	40.3	106	35	9.0	3.9	67	45
800	176	81.0	677	73.8	23.35	35.2	120	39	98.8	4.1	74	50
900	198	91.0	762	83.0	26.30	31.3	135	41	10.7	4.3	82	57
1000	220	100.7	896	92.1	29.20	28.2	149	43	11.5	4.5	90	62
1500	330	150	1270	138.2	43.80	18.7	—	65	15.2	6.3	132	90
2000	440	200	1690	184.2	58.40	14.1	—	86	19.5	7.5	172	118
2500	550	250	2120	230	73.0	11.3	—	108	24	9	218	147
3000	660	300	2540	276	87.60	9.4	—	129	28.5	11	258	172
4000	880	400	3380	368	117.0	7.05	—	172	37	14	337	230
5000	1100	500	4230	461	146	5.64	—	215	47	18	425	290
6000	1320	600	5080	553	175	4.70	—	258	57	22	520	350

**TABLE 7** Continued.

Saybolt seconds universal SSU	Kinematic viscosity, cSt <sup>a</sup>	Saybolt seconds Furoil SSF	Seconds, Redwood 1 (standard)	Seconds, Redwood 2 (admiralty)	Degrees, Engler	Degrees, Barbey	Seconds, Parlin cup 7	Seconds, Parlin cup 10	Seconds, Parlin cup 15	Seconds, Parlin 20	Seconds, Ford cup 3	Seconds, Ford cup 4
7000	1540	700	5920	645	204.5	4.03	—	300	67	25	600	410
8000	1760	800	6770	737	233.5	3.52	—	344	76	29	680	465
9000	1980	900	7620	829	263	3.13	—	387	86	32	780	520
10,000	2200	1000	8460	921	292	2.82	—	430	96	35	850	575
15,000	3300	1500	13,700	—	438	2.50	—	650	147	53	1280	860
20,000	4400	2000	18,400	—	584	1.40	—	860	203	70	1715	1150

$$^a\text{Kinematic viscosity (in centistokes)} = \frac{\text{absolute viscosity (in centipoises)}}{\text{density}}$$

When the SI units centistokes and centipoises are used, the density is numerically equal to the specific gravity. Therefore, the following will be sufficiently accurate for most calculations:

$$\text{Kinematic viscosity (in centistokes)} = \frac{\text{absolute viscosity (in centipoises)}}{\text{specific gravity}}$$

When USCS units are used, the density must be used rather than the specific gravity.

Note: For values of 70 cSt and above, use the conversion

$$\text{SSU} = \text{centistokes} \times 4.635$$

Above the range of this table and within the range of the viscosimeter, multiply the particular value by the following approximate factors to convert to SSU:

Viscosimeter	Factor	Viscosimeter	Factor
Saybolt Furoil	10.	Parlin cup #15	98.2
Redwood Standard	1.095	Parlin cup #20	187.0
Redwood Admiralty	10.87	Ford cup #4	17.4
Engler, degrees	34.5		

Source: *Hydraulic Institute Engineering Data Book*, 2nd Edition, 1990, Hydraulic Institute, Parsippany, NJ

**TABLE 8** Properties of water at temperatures from 40 to 705.4°F (4.4 to 374.1°C)

°F	°C	Specific volume <sup>a</sup> , ft <sup>3</sup> /lb	Specific gravity			Wt <sup>b</sup> , lb/ft <sup>3</sup>	Vapor pressure <sup>c</sup> , lb/in <sup>2</sup> abs
			39.2°F reference	60°F reference	70°F reference		
40	4.4	0.01602	1.000	1.001	1.002	62.42	0.1217
50	10.0	0.01603	0.999	1.001	1.002	62.38	0.1781
60	15.6	0.01604	0.999	1.000	1.001	62.34	0.2563
70	21.1	0.01606	0.998	0.999	1.000	62.27	0.3631
80	26.7	0.01608	0.996	0.998	0.999	62.19	0.5069
90	32.2	0.01610	0.995	0.996	0.997	62.11	0.6982
100	37.8	0.01613	0.993	0.994	0.995	62.00	0.9492
120	48.9	0.01620	0.989	0.990	0.991	61.73	1.692
140	60.0	0.01629	0.983	0.985	0.986	61.39	2.889
160	71.1	0.01639	0.977	0.979	0.979	61.01	4.741
180	82.2	0.01651	0.970	0.972	0.973	60.57	7.510
200	93.3	0.01663	0.963	0.964	0.966	60.13	11.526
212	100.0	0.01672	0.958	0.959	0.960	59.81	14.696
220	104.4	0.01677	0.955	0.956	0.957	59.63	17.186
240	115.6	0.01692	0.947	0.948	0.949	59.10	24.97
260	126.7	0.01709	0.938	0.939	0.940	58.51	35.43
280	137.8	0.01726	0.928	0.929	0.930	58.00	49.20
300	148.9	0.01745	0.918	0.919	0.920	57.31	67.01
320	160.0	0.01765	0.908	0.909	0.910	56.66	89.66
340	171.1	0.01787	0.896	0.898	0.899	55.96	118.01
360	182.2	0.01811	0.885	0.886	0.887	55.22	153.04
380	193.3	0.01836	0.873	0.874	0.875	54.47	195.77
400	204.4	0.01864	0.859	0.860	0.862	53.65	247.31
420	215.6	0.01894	0.846	0.847	0.848	52.80	308.83
440	226.7	0.01926	0.832	0.833	0.834	51.92	381.59
460	237.8	0.0196	0.817	0.818	0.819	51.02	466.0
480	248.9	0.0200	0.801	0.802	0.803	50.00	566.1
500	260.0	0.0204	0.785	0.786	0.787	49.02	680.8
520	271.1	0.0209	0.765	0.766	0.767	47.85	812.4
540	282.2	0.0215	0.746	0.747	0.748	46.51	962.5
560	293.3	0.0221	0.726	0.727	0.728	45.3	1133.1
580	304.4	0.0228	0.703	0.704	0.704	43.9	1325.8
600	315.6	0.0236	0.678	0.679	0.680	42.3	1542.9
620	326.7	0.0247	0.649	0.650	0.650	40.5	1786.6
640	337.8	0.0260	0.617	0.618	0.618	38.5	2059.7
660	348.9	0.0278	0.577	0.577	0.578	36.0	2365.4
680	360.0	0.0305	0.525	0.526	0.527	32.8	2708.1
700	371.1	0.0369	0.434	0.435	0.435	27.1	3093.7
705.4	374.1	0.0503	0.319	0.319	0.320	19.9	3206.2

<sup>a</sup>1 m<sup>3</sup>/kg = 16.02 ft<sup>3</sup>/lb<sup>b</sup>1 kg/m<sup>3</sup> = 0.06243 lb/ft<sup>3</sup><sup>c</sup>1 kPa = 0.145 lb/in<sup>2</sup>; 1 bar = 14.5 lb/in<sup>2</sup>Source: *Hydraulic Institute Engineering Data Book*, 2nd Edition, 1990, Hydraulic Institute, Parsippany, NJ

**TABLE 9** Conversions of USCS to SI units

The first two digits of each numeral entry represent a power of 10. An asterisk follows each number that expresses an exact definition.

<b>Acceleration</b>		
To convert from	to	multiply by
foot/second <sup>2</sup>	meter/second <sup>2</sup>	-01 3.048*
free fall, standard	meter/second <sup>2</sup>	+00 9.806 65*
gal (galileo)	meter/second <sup>2</sup>	-02 1.00*
inch/second <sup>2</sup>	meter/second <sup>2</sup>	-02 2.54*

<b>Area</b>		
To convert from	to	multiply by
acre	meter <sup>2</sup>	+03 4.046 856 4224*
circular mil	meter <sup>2</sup>	-10 5.067 074 8
foot <sup>2</sup>	meter <sup>2</sup>	-02 9.290 304*
inch <sup>2</sup>	meter <sup>2</sup>	-04 6.4516*
mile <sup>2</sup> (U.S. statute)	meter <sup>2</sup>	+06 2.589 988 110 336*
yard <sup>2</sup>	meter <sup>2</sup>	-01 8.361 273 6*

<b>Density</b>		
To convert from	to	multiply by
gram/centimeter <sup>3</sup>	kilogram/meter <sup>3</sup>	+03 1.00*
lbm/inch <sup>3</sup>	kilogram/meter <sup>3</sup>	+04 2.767 990 5
lbm/foot <sup>3</sup>	kilogram/meter <sup>3</sup>	+01 1.601 846 3
slug/foot <sup>3</sup>	kilogram/meter <sup>3</sup>	+02 5.153 79

<b>Energy</b>		
To convert from	to	multiply by
British thermal unit (ISO/TC 12)	joule	+03 1.055 06
British thermal unit (International Steam Table)	joule	+03 1.055 04
British thermal unit (mean)	joule	+03 1.055 87
British thermal unit (thermochemical)	joule	+03 1.054 350 264 488
British thermal unit (39°F)	joule	+03 1.059 67
British thermal unit (60°F)	joule	+03 1.054 68
calorie (International Steam Table)	joule	+00 4.1868
calorie (mean)	joule	+00 4.190 02
calorie (thermochemical)	joule	+00 4.184*
calorie (15°C)	joule	+00 4.185 80

<b>Length</b>		
To convert from	to	multiply by
fathom	meter	+00 1.8288*
foot	meter	-01 3.048*
foot (U.S. survey)	meter	+00 1.200/3937*
foot (U.S. survey)	meter	-01 3.048 006 096
furlong	meter	+02 2.011 68*
inch	meter	-02 2.54*
league (U.K. nautical)	meter	03 5.559 552*
league (international nautical)	meter	+03 5.556*
league (statute)	meter	+03 4.828 032*
light-year	meter	+15 9.460 55
meter	wavelengths Kr 86	+06 1.650 763 73*
micron	meter	-06 1.00*
mil	meter	-05 2.54*
mile (U.S. statute)	meter	+03 1.609 344*
mile (U.K. nautical)	meter	+03 1.853 184*
mile (international nautical)	meter	+03 1.852*
mile (U.S. nautical)	meter	+03 1.852*
nautical mile (U.K.)	meter	+03 1.853 184*
nautical mile (international)	meter	+03 1.852*
nautical mile (U.S.)	meter	+03 1.852*
rod	meter	+00 5.0292*
statute mile (U.S.)	meter	+03 1.609 344*
yard	meter	-01 9.144*

<b>Mass</b>		
To convert from	to	multiply by
carat (metric)	kilogram	-04 2.00*
grain	kilogram	-05 6.479 891*
gram	kilogram	-03 1.00*
kgf second <sup>2</sup> meter (mass)	kilogram	+00 9.806 65*
kilogram mass	kilogram	+00 1.00*
lbm (pound mass, avoirdupois)	kilogram	-01 4.535 923 7*
ounce mass (avoirdupois)	kilogram	-02 2.834 952 312 5*
ounce mass (troy or apothecary)	kilogram	-02 3.110 347 68*
pennyweight	kilogram	-03 1.555 173 84*
pound mass, lbm (avoirdupois)	kilogram	-01 4.535 923 7*
pound mass (troy or apothecary)	kilogram	-01 3.732 417 216*
slug	kilogram	+01 1.459 390 29
ton (assay)	kilogram	-02 2.916 666 6
ton (long)	kilogram	+03 1.016 046 908 8*

**TABLE 9** Continued.

Energy		
To convert from	to	multiply by
calorie (20°C)	joule	+00 4.181 90
calorie (kilogram, International Steam Table)	joule	+03 4.1868
calorie (kilogram, mean)	joule	+03 4.190 02
calorie (kilogram, thermochemical)	joule	+03 4.184*
electronvolt	joule	-19 1.602 10
erg	joule	-07 1.00*
foot pound force (ft • lbf)	joule	+00 1.355 817 9
foot poundal	joule	-02 4.214 011 0
joule (international of 1948)	joule	+00 1.000 165
kilocalorie (International Steam Table)	joule	+03 4.1868
kilocalorie (mean)	joule	+03 4.190 02
kilocalorie (thermochemical)	joule	+03 4.184*
kilowatthour	joule	+06 3.60*
kilowatthour (international of 1948)	joule	+06 3.600 59
ton (nuclear equivalent of TNT)	joule	+09 4.20
watthour	joule	+03 3.60*

Energy/Area Time		
To convert from	to	multiply by
Btu (thermochemical)/foot <sup>2</sup> second	watt/meter <sup>2</sup>	+04 1.134 893 1
Btu (thermochemical)/foot <sup>2</sup> minute	watt/meter <sup>2</sup>	+02 1.891 488 5
Btu (thermochemical)/foot <sup>2</sup> hour	watt/meter <sup>2</sup>	+00 3.152 480 8
Btu (thermochemical)/inch <sup>2</sup> second	watt/meter <sup>2</sup>	+06 1.634 246 2
calorie (thermochemical)/cm <sup>2</sup> minute	watt/meter <sup>2</sup>	+02 6.973 333 3
erg/centimeter <sup>2</sup> second	watt/meter <sup>2</sup>	-03 1.00*
watt/centimeter <sup>2</sup>	watt/meter <sup>2</sup>	+04 1.00*

Force		
To convert from	to	multiply by
dyne	newton	-05 1.00*
kilogram force (kgf)	newton	+00 9.806 65*
kilopond force	newton	+00 9.806 65*
kip	newton	+03 4.448 221 615 260 5*
lbf (pound force, avoirdupois)	newton	+00 4.448 221 615 260 5*
ounce force (avoirdupois)	newton	-01 2.780 138 5
pound force lbf (avoirdupois)	newton	+00 4.448 221 615 260 5*
poundal	newton	-01 1.382 549 543 76*

Mass		
To convert from	to	multiply by
ton (metric)	kilogram	+03 1.00*
ton (short, 2000 pound)	kilogram	+02 9.071 847 4*

Power		
To convert from	to	multiply by
Btu (thermochemical)/second	watt	+03 1.054 350 264 488
Btu (thermochemical)/minute	watt	+01 1.757 250 4
calorie (thermochemical)/second	watt	+00 4.184*
calorie (thermochemical)/minute	watt	-02 6.973 333 3
foot lbf/hour	watt	-04 3.766 161 0
foot lbf/minute	watt	-02 2.259 696 6
foot lbf/second	watt	+00 1.355 817 9
horsepower (550 foot lbf/second)	watt	+02 7.456 998 7
horsepower (boiler)	watt	+03 9.809 50
horsepower (electric)	watt	+02 7.46*
horsepower (metric)	watt	+02 7.354 99
horsepower (U.K.)	watt	+02 7.457
horsepower (water)	watt	+02 7.460 43
kilocalorie (thermochemical)/minute	watt	+01 6.973 333 3
kilocalorie (thermochemical)/second	watt	+03 4.184*
watt (international of 1948)	watt	+00 1.000 165

Pressure		
To convert from	to	multiply by
atmosphere	newton/meter <sup>2</sup>	+05 1.013 25*
bar	newton/meter <sup>2</sup>	+05 1.00*
centimeter of mercury (0°C)	newton/meter <sup>2</sup>	+03 1.333 22
centimeter of water (4°C)	newton/meter <sup>2</sup>	+01 9.806 38
dyne/centimeter <sup>2</sup>	newton/meter <sup>2</sup>	-01 1.00*
foot of water (39.2°F)	newton/meter <sup>2</sup>	+03 2.988 98
inch of mercury (32°F)	newton/meter <sup>2</sup>	+03 3.386 389
inch of mercury (60°F)	newton/meter <sup>2</sup>	+03 3.376 85
inch of water (39.2°F)	newton/meter <sup>2</sup>	+02 2.490 82
inch of water (60°F)	newton/meter <sup>2</sup>	+02 2.4884
kgf/centimeter <sup>2</sup>	newton/meter <sup>2</sup>	+04 9.806 65*
kgf/meter <sup>2</sup>	newton/meter <sup>2</sup>	+00 9.806 65*
lbf/foot <sup>2</sup>	newton/meter <sup>2</sup>	+01 4.788 025 8

**TABLE 9** Continued.

Pressure		
To convert from	to	multiply by
lbf/inch <sup>2</sup> (psi)	newton/meter <sup>2</sup>	+03 6.894 757 2
millibar	newton/meter <sup>2</sup>	+02 1.00*
millimeter of mercury (0°C)	newton/meter <sup>2</sup>	+02 1.333 224
pascal	newton/meter <sup>2</sup>	+00 1.00*
psi (lbf/inch <sup>2</sup> )	newton/meter <sup>2</sup>	+03 6.894 757 2

Speed		
To convert from	to	multiply by
foot/hour	meter/second	-05 8.466 666 6
foot/minute	meter/second	-03 5.08*
foot/second	meter/second	-01 3.048*
inch/second	meter/second	-02 2.54*
kilometer/hour	meter/second	-01 2.777 777 8
knot (international)	meter/second	-01 5.144 444 444
mile/hour (U.S. statute)	meter/second	-01 4.4704*
mile/minute (U.S. statute)	meter/second	+01 2.682 24*
mile/second (U.S. statute)	meter/second	+03 1.609 344*

Temperature		
To convert from	to	proceed as follows
Celsius	Kelvin	$t_K = t_C + 273.15$
Fahrenheit	Kelvin	$t_K = (\frac{5}{9})(t_F + 459.67)$
Fahrenheit	Celsius	$t_C = (\frac{5}{9})(t_F - 32)$
Rankine	Kelvin	$t_K = (\frac{5}{9})t_R$

Viscosity		
To convert from	to	multiply by
centistoke	meter <sup>2</sup> /second	-06 1.00*
stoke	meter <sup>2</sup> /second	-04 1.00*
foot <sup>2</sup> /second	meter <sup>2</sup> /second	-02 9.290 304*
centipoise	newton second/meter <sup>2</sup>	-03 1.00*
lbm/foot second	newton second/meter <sup>2</sup>	+00 1.488 163 9
lbf second/foot <sup>2</sup>	newton second/meter <sup>2</sup>	+01 4.788 025 8

Viscosity		
To convert from	to	multiply by
poise	newton second/meter <sup>2</sup>	-01 1.00*
poundal second/foot <sup>2</sup>	newton second/meter <sup>2</sup>	+00 1.488 163 9
slug/foot second	newton second/meter <sup>2</sup>	+01 4.788 025 8
rhe	meter <sup>2</sup> /newton second	+01 1.00*

Volume		
To convert from	to	multiply by
acre foot	meter <sup>3</sup>	+03 1.233 481 9
barrel (petroleum, 42 gallons)	meter <sup>3</sup>	-01 1.589 873
bushel (U.S.)	meter <sup>3</sup>	-02 3.523 907 016 688*
cord	meter <sup>3</sup>	+00 3.624 556 3
cup	meter <sup>3</sup>	-04 2.365 882 365*
dram (U.S. fluid)	meter <sup>3</sup>	-06 3.696 691 195 312 5*
fluid ounce (U.S.)	meter <sup>3</sup>	-05 2.957 352 956 25*
foot <sup>3</sup>	meter <sup>3</sup>	-02 2.831 684 659 2*
gallon (U.K. liquid)	meter <sup>3</sup>	-03 4.546 087
gallon (U.S. dry)	meter <sup>3</sup>	-03 4.404 883 770 86*
gallon (U.S. liquid)	meter <sup>3</sup>	-03 3.785 411 784*
gill (U.S.)	meter <sup>3</sup>	-04 1.182 941 2
inch <sup>3</sup>	meter <sup>3</sup>	-05 1.638 706 4*
liter	meter <sup>3</sup>	-03 1.00*
ounce (U.S. fluid)	meter <sup>3</sup>	-05 2.957 352 956 25*
peck (U.S.)	meter <sup>3</sup>	-03 8.809 767 541 72*
pint (U.S. dry)	meter <sup>3</sup>	-04 5.506 104 713 575*
pint (U.S. liquid)	meter <sup>3</sup>	-04 4.731 764 73*
quart (U.S. dry)	meter <sup>3</sup>	-03 1.101 220 942 715*
quart (U.S. liquid)	meter <sup>3</sup>	-04 9.463 529 5
tablespoon	meter <sup>3</sup>	-05 1.478 676 478 125*
teaspoon	meter <sup>3</sup>	-06 4.928 921 593 75*
ton (register)	meter <sup>3</sup>	+00 2.831 684 659 2*
yard <sup>3</sup>	meter <sup>3</sup>	-01 7.645 548 579 84*

Volume/Unit Time		
To convert from	to	multiply by
gallon/minute	meter <sup>3</sup> /second	-05 6.309 020
gallon/minute	meter <sup>3</sup> /hour	-01 2.271 247
gallon/minute	liter/second	-02 6.309 020

---

# INDEX

## A

- abnormal operations, centrifugal pumps, 2.376
- aboveground discharge pumps, 2.99
- abrasive wear, 5.16, 5.18
  - composite pumps, 5.50
  - packings, 2.192
  - particulates, 5.20
  - rotary pumps, 3.137
  - slurry pumps, 9.364
  - water supply systems, 9.9
- absolute viscosities, 8.32
- AC adjustable-voltage drives, 6.110–6.111
- AC electric motors, 6.3
- acceleration, electric motors, 6.23–6.24
- accelerators, solutions, 9.115
- accelerometers, 2.422
- accessories, fire protection systems, 9.70
- accumulators, 9.464
- accuracy in testing pumps, 13.8
- acid sulfite pulping process, 9.160
- acidic solutions, 9.114
- acoustic filters, displacement pumps, 3.68
- acoustic treatments, gas turbines, 6.93
- acoustic velocities, displacement pump piping systems, 3.64–3.65
- active magnetic bearings, 2.282
- actuators, control valves, 7.23, 7.26
- adhesive wear, 5.14–5.15
- adjustable blade propeller turbines, 6.79
- adjustable rigid couplings, 6.176
- adjustable vanes, centrifugal pumps, 2.367
- adjustable–frequency drives
  - frequency inverters, 6.118
  - solid state adjustable–frequency inverters, 6.119–6.120

- adjustable-speed belt drives, 6.167
  - applications, 6.173
  - control systems, 6.173
  - gear reduction, 6.169
  - input speed, 6.168
  - operations, 6.170
  - output torque, 6.172
  - ratings, 6.172
  - service factoring, 6.172
  - speed control, 6.169
  - V belts, 6.170
- aerated solutions, 9.114
- affinity laws
  - rotary pumps, 3.132
  - turbines, 6.84
- agricultural pumps
  - transfer systems, 9.441–9.442
  - water usage, 9.5
- air admission, centrifugal pumps, 2.367
- air chambers, waterhammer prevention, 8.101–8.103
- air cleaners, engines, 6.69
- air conditioning chilled water marine pumps, 9.236
- air conditioning pumps, 9.257
- air intake systems, engines, 6.68
- air leakage, stuffing boxes, 2.192
- air lift eductors, 4.47
- air motor starters, engines, 6.71
- air siphons, 4.47
- air ventilation, hot water pumps, 9.254
- air-cooled eddy current couplings, enclosures, 6.105
- air-separating tanks, 2.465
- airborne noise, 8.117–8.122
- aircraft fuel pumps, 9.409–9.411
  - altitude climb performance, 9.415–9.416
  - boost pumps, 9.412–9.414, 9.418
  - constant altitude performance, 9.416
  - contaminated fuels, 9.429
  - gear stage cyclic durability, 9.428
  - gear stage volumetric performance, 9.428
  - low lubricity fuels, 9.429
  - main fuel pump, 9.416–9.417, 9.420–9.427
  - motor speeds, 9.414
  - performance, 9.414
  - pressure rise, 9.414–9.415
  - types of fuel, 9.415
  - vapor lock, 9.419
- aircraft refueling cryogenic pumps, 9.401
- aircraft-derivative split shaft gas turbines, 6.91
- alignment
  - engines, 6.74
  - gear reducers, 6.160
  - mechanical performance impact, 2.412–2.417
  - pumps, 12.3–12.4, 12.7
- alignment issues, screw pumps, 3.120
- alkaline solution chemical pumps, 9.114, 9.117
- alkalinity, water supply systems, 9.9
- alloys, corrosion factors, 5.7
- alternators, multipump control systems, 7.7
- altitude climb performance, aircraft fuel pumps, 9.415–9.416
- amnifold pumps, piping, 10.29
- amplitude, vibration analysis, 2.419–2.424
- angular contact bearings, 2.151–2.152
- angular misalignment, 2.228
- annual inspections, 12.17
- annular siphons, 4.44
- antifriction bearings
  - power pumps, 3.34
  - vibration, 2.434
- AODPs (air-operated diaphragm pumps)
  - applications, 3.95
  - ball valves, 3.92
  - check valves, 3.93
  - flap valves, 3.92
  - limitations, 3.97
  - pumping dry powders, 3.97



- API Standard 682, 2.215
- applications
- adjustable-speed belt drives, 6.173
  - canned motor pumps, 2.318
  - eddy current couplings, 6.106
  - eductors, 4.30
  - flexible couplings, 6.181–6.182
  - food/beverage pumps, 9.188
  - gas turbines, 6.94–6.96
  - hydraulic water pumps, 6.193
  - jet pumps, 4.20
  - rigid couplings, 6.176
- approach channels, intake
- design, 10.46
- ARC valves (Automatic Recirculation Control), 2.444
- Archimedean screw, 1.2
- area ratio, L/JL pumps, 4.12, 4.16
- artificial lift, oil well pumps, 9.377
- ash handling pumps, 9.111
- atmospheric gases, cryogenic pumps, 9.400
- Austenitic iron casings, 5.29
- Austenitic stainless steel
- casings, 5.29
  - impellers, 5.27
  - stress corrosion cracking, 5.7
- automatic controls, mining pumps, 9.211
- automatic packings, 2.183
- auxiliary bearings. *See* catcher bearings.
- auxiliary circulating pumps, steam turbogenerators, 9.228
- auxiliary condensate pumps, steam turbogenerators, 9.228
- auxiliary services, standby pumps, 12.16
- auxiliary starters, engines, 6.71
- average daily demand, water supply systems, 9.5
- axial clearances, wearing rings, 2.121
- axial lengths, centrifugal pumps, 2.29
- axial magnet forces, sealless magnetic drive pumps, 2.304
- axial thrust, 2.401
- axial-flow impellers, 2.127
  - boiler circulating pumps, 2.127
  - centrifugal pumps, 2.53–2.54
  - double-suction impellers, 2.124
  - high-energy pumps, recirculation response, 2.79
  - hydraulic balancing devices, 2.129
  - impellers, 2.124–2.125
  - multistage pumps, 2.128
  - overhung impellers, 2.126
  - radial impellers, 2.127
  - semiopen impellers, 2.127
  - single-stage pumps, 2.124
  - single-suction impellers, 2.126–2.128
  - vertical pumps, 2.171–2.172
- axial unbalances, 2.125
- axial unloading, ball bearings, 2.152
- axial-flow impellers, 2.113, 2.127
- axially split casings, 2.102
- interstage passages, 2.108
  - throat bushings, 2.141
- axially split pumps, 2.99

## B

- babbitted bearings, 2.149
- babbits, 2.273
- backflow
- high-energy pump cavitation, 2.86
  - preventers, 2.143
- backup systems, magnetic bearings, 2.279
- backward curved blades, centrifugal pumps, 2.331
- balance
- couplings, 6.182
  - seals, 2.200–2.201, 2.211
- balanced piston valves, duplex steam pumps, 3.44
- balancing drum/disk units, hydraulic balancing devices, 2.129–2.131

- ball bearings, 2.149
  - angular contact, 2.151
  - double-row angular contact, 2.152
  - electric motors, 6.17
  - lubrication, 2.153
  - sealed, 2.150
  - self-aligning, 2.151
  - single-row angular contact, 2.151
  - single-row deep-groove, 2.151
- ball thrust bearings, 2.150
- ball valves
  - AODPs, 3.92
  - control valves, 7.16
- ballast pumps, 9.234
- bar racks, head losses, 8.73
- barrier fluid, 2.216
- baseplates, 2.156
  - drain pockets, 2.156
  - vibration, 2.435
- beam pumping units, 9.386
- bearing cases, single-stage steam turbines, 6.41
- bearings, 2.149
  - ball bearings, 2.150
  - canned motor pumps, 2.316
    - environment control, 2.321
  - critical mass, 2.270–2.271
  - cross coupling, 2.267
  - defective, 2.406
  - electric motors, 6.17–6.18
  - gears, lubrication, 6.161
  - heat balancing, 2.263–2.266
  - hydrokinetic drives, 6.129
  - inboard, 2.149
  - line, 2.149
  - lubrication, 2.152
  - magnetic. *See* magnetic bearings.
  - outboard, 2.149
  - pedestal, 2.149
  - propulsion marine pumps, 9.219
  - rolling element, 2.149
  - rotor whirl, 2.266
  - sealless magnetic drive pumps, 2.308–2.310
  - self-aligning, 2.149
  - sewage systems, 9.42
  - slurry pumps, 9.357
  - spring and damping coefficients, 2.268
  - squeeze film effect, 2.252
  - stability, 2.270–2.273
  - stability analyses, 2.268
  - static radial load damage, 2.403
  - static thrust, 2.401
  - thrust, 2.149
  - vertical dry-pit pumps, 2.160
  - viscosity, 2.258
- bedplates, 2.155
  - composite pumps, 5.61
  - drain surfaces, 2.157
- below-ground discharge pumps, 2.99
- bends in pipes, resistance coefficients, 8.65
- BEP (Best Efficiency Point), 2.327, 2.437
- Bernoulli constant, 2.15
- BEs (operating Basis Earthquakes), seismic nuclear pumps, 9.304
- beverage pumps, 9.187–9.188
  - positive displacement, 9.190
  - rotodynamic, 9.189
  - seals, 9.193
  - types, 9.189–9.190, 9.193
- Bhp (brake horsepower), power pumps, 3.4
- bid requisitions. *See* RFQs.
- bidders lists, RFQs, 11.20–11.22
- bilge pumps, 9.232
- biologically-induced corrosion, 5.10
- black liquor, paper mill pumps, 9.163–9.164
- blades
  - centrifugal pumps, 2.33
    - determining number, 2.36–2.38
    - determining shape, 2.39–2.40
    - inlet, 2.34
    - outlet, 2.34–2.35
  - high-energy pumps, vane combinations, 2.76–2.77
- bleach liquors, paper mill pumps, 9.164
- bleaching pulp, 9.160

- blockages, centrifugal pumps, 2.61
- blow tanks, paper mill pumps, 9.163
- boiler circulating pumps, 2.127, 9.108–9.109
- boiler feed pumps
  - cavitation, 9.92, 9.94
  - constant speed control systems, 7.11–7.13
  - drivers, 9.90
  - efficiencies, 9.94–9.95
  - reduced flow operation, 9.90
  - steam power plants, 9.77
    - capacities, 9.78
    - load reduction, 9.79–9.81
    - NPSH, 9.78–9.79
  - working pressures, 9.87
- boiler injectors, 4.48
- boiler-feed water condensate, 5.35
- booster pumps
  - aircraft fuel systems, 9.412–9.414, 9.418
  - steam power plants, 9.84
  - water treatment plants, 9.19
- Boron injection recirculation pumps, PWR plants, 9.280
- bottom-suction pumps, 2.106
- boundary blockages, centrifugal pumps, 2.61
- boundary layer theory, fluid mechanics, 2.249
- Bourdon gages, measuring head, 13.35
- brake horsepower (bhp)
  - gas turbines, 6.96
  - steam pumps, 3.58
- branch-line pumping systems
  - closed loop, 8.83–8.84
  - flow control, 8.88
  - open-ended systems, 8.84, 8.86
  - total head, 8.90
- Brayton cycle, gas turbines, 6.89
- breakaway torque
  - centrifugal pumps, 2.360
  - power pumps, 3.8
  - sealless magnetic drive pumps, 2.303
- brine pumps, 9.259
- bronze
  - casings, 5.29
  - impellers, 5.26
  - wear rings, 5.31
- brushless DC motors, 6.10–6.12
- brushless synchronous motors, 6.7
- buffer fluids, 2.216
- building water pressure control systems, 7.14
- butterfly control valves, 7.16
- BWR plants (boiling water reactor), 9.279
  - closed cooling water pumps, 9.284
  - control rod drive pumps, 9.284
  - fuel pool cooling pumps, 9.285
  - high-pressure core spray pumps, 9.285
  - jet pumps, 9.283
  - low-pressure core spray pumps, 9.285
  - main coolant pumps, 9.287, 9.290
  - reactor core isolation cooling pumps, 9.285
  - reactor water cleanup pumps, 9.284
  - recirculation pumps, 9.283
  - RHR pumps, 9.285
  - standby liquid control systems, 9.285
- bypass control and regulation
  - centrifugal pumps, 2.367
  - condensate pumps, 9.102
  - displacement pumps, 3.78
- bypass flow, 2.439
- bypass orifices, 8.87
- bypass systems
  - controls, 2.450
  - fixed orifices, 2.448
  - low flow protection, 2.441–2.444
  - orifice issues, 2.448
  - PRVs, 2.448
  - pumps in parallel, 2.450
  - variable orifices, 2.448

## C

- cage control valves, 7.16–7.17
- calculated wear factors, 5.31
- calibration, metering pumps, 9.317
- canned motor pumps, 2.315
  - applications, 2.318
  - bearings, 2.316
    - environment control, 2.321
  - diagnostics, 2.322
  - filter assembly, 2.318
  - flow path, 2.318
  - installing, 2.321
  - intakes, 10.26
  - internal clearances, 2.318
  - pressure temperature
    - profiles, 2.321
  - recirculation fluid, 2.321
  - rotors, 2.316–2.318
  - secondary containment, 2.318
  - stator liners, 2.318
  - stators, 2.315
  - thrust balance, 2.319–2.321
  - vertical condensate pumps, 9.97
- cantilever shaft pumps, 2.168
- capacities
  - drainage pumps, 9.48
  - hydrodynamic drives, 6.135
  - hydrokinetic drives, 6.134
  - hydroviscous drives, 6.136
  - irrigation pumps, 9.48
  - metering pumps, 9.317
  - paper mill pumps, 9.175
  - power pumps, 3.4
  - rotary pumps, 3.139–3.140
  - screw pumps, 3.115
  - vane pumps, 3.140
  - water supply systems, 9.6
  - well pumps, 9.22
- capacity planning
  - electronic pumps, 3.88
  - sewage pumps, 9.37
- carbon pumps, 5.53
- carbon slurry pumps, water
  - treatment plants, 9.17
- carbon steel shafts, 5.30
- carburizing gears, 6.150
- cargo marine pumps,
  - 9.237–9.238, 9.241
- casing cover rings, leakage
  - joints, 2.118
- casing housing, rotary pumps, 3.124
- casing rings
  - leakage joints, 2.118
  - restricting movement, 2.123
- casing sealing glands, single-stage
  - steam turbines, 6.41
- casing tongues, centrifugal pumps,
  - reducing size, 2.347
- casings, 2.102
  - feet location, 2.110
  - handholes, 2.107
  - hydrokinetic drives, 6.129
  - hydrostatic tests, 2.111
  - materials of construction,
    - 5.28–5.29
  - mechanical features, 2.107
  - multistage pumps, 2.107, 2.110
  - single-stage steam turbines, 6.41
  - slurry pumps, 9.357
- cast cylinders, power pumps, 3.22
- cast iron
  - casings, 5.28
  - flanges, 2.110
  - impellers, 5.27
  - wear rings, 5.32
- catcher bearings, 2.279, 2.284
- cavitation, 2.224, 2.248,
  - 2.397–2.398, 2.448
  - boiler feed pumps, 9.92–9.94
  - centrifugal pumps, 2.347,
    - 2.356–2.357
  - control valves, 7.23
  - high-energy pumps
    - backflow, 2.86
    - erosion effects, 2.71, 2.88
    - instabilities, 2.87
    - pressure pulsations, 2.87
  - LJL pumps, 4.11, 4.17
  - noise sources, 8.111–8.113
  - resistance, 5.13
  - rotary pumps, 3.135

- testing pumps, 13.10
- turbines, 6.83
- cavitation erosion, 5.11
- cavitation limited flow ratios, L<sub>JL</sub> pumps, 4.15, 4.19
- cellar drainers, volute pumps, 2.169
- centerline footings, 2.110
- centerline pump support, 2.157
- centipoises, 8.33
- centralized multi-pump priming systems, 2.459
- centrifugal pumps, 2.3, 2.21
  - abnormal operations, 2.376
  - adjustable vanes, 2.367
  - air admission, 2.367
  - aircraft fuel, 9.411
  - axial lengths, 2.29
  - blades, 2.33–2.34
    - determining number, 2.36–2.38
    - determining shape, 2.39–2.40
  - boundary blockages, 2.61
  - breakaway torque, 2.360
  - bypass orifices, 8.87
  - bypass regulation, 2.367
  - casing tongues, reducing size, 2.347
  - cavitation, 2.347
    - reducing damage, 2.356
    - resistant materials, 2.357
  - chemical, 9.120
  - collectors, 2.41
  - component efficiencies, 2.11–2.12
  - defective bearings, 2.406
  - designing, 2.27, 2.406
  - diffusion assessments, 2.66
  - discharge
    - recirculation, 2.370
    - throttling, 2.366
  - drainage. *See* drainage pumps.
  - drivers, torque characteristics, 2.359–2.360
  - dynamic instability, 2.56
  - efficiencies, 2.60–2.61, 2.329, 2.382–2.383
    - increasing impeller speed, 2.334
  - electromagnetic effects, 2.27
  - emulsions, 2.27
  - energy transfer, 2.9
  - entrained air, 2.358
  - entrained gases, 2.26
  - Euler's Pump Equation, 2.13
  - exit radius, 2.30
  - extended Bernoulli equation, 2.15
  - first law of thermodynamics, 2.9
  - flow rate, 2.327, 2.351
    - regulation, 2.365
  - head, 2.328
  - heat of compression, 2.11
  - high specific speed, 2.364
  - hubs, profiles, 2.31, 2.33, 2.62
  - hydraulic efficiency, 2.334
  - hydraulic geometry, 2.21
  - impellers, 2.29
    - blades, 2.64
    - diffusion effects, 2.15
    - eyes, 2.29
    - inlets, 2.58–2.59
    - outlets, 2.59
      - reducing diameter, 2.338–2.339
      - reversed installation, 2.382
  - incorrect driver rotation, 2.382
  - inducers, 2.358
  - inlets
    - blades, 2.34
    - velocity diagrams, 2.64
  - internal static pressure distribution, 2.16
  - irrigation. *See* irrigation pumps.
  - L<sub>JL</sub> pump interaction, 4.19
  - losses, 2.11
  - low specific speed, 2.361–2.362
  - marine cargo, 9.237
  - mechanical issues
    - critical speed, 2.409
    - efficiency, 2.334
    - mechanical performance, 2.405–2.406
  - medium specific speed, 2.364
  - mixed-flow impellers, reducing diameter, 2.339
  - moments of forces, 2.13
  - Moody-Stauffer formula, 2.383

NPSH, 2.16–2.17, 2.25,  
     2.349–2.351, 2.355  
 operating, 12.13–12.14  
 outlets  
     blades, 2.34–2.35  
     velocity diagrams, 2.64  
 overfiling vanes, 2.343  
 parallel operation, 2.367–2.368  
 performance, 2.24, 2.334  
     axial thrust, 2.53–2.54  
     backward-curved blades, 2.331  
     CFD, 2.51–2.52  
     characteristic curves, 2.18, 2.46  
     estimates, 2.69  
     forward-curved blades, 2.332  
     mechanical efficiency, 2.50  
     non-recirculating flows, 2.46  
     non-viscous flows, 2.329–2.330  
     radial blades, 2.332  
     stability, 2.56  
     viscous flow, 2.331  
     volumetric efficiency, 2.50  
 pipeline applications, 9.142  
 pitting, 2.347  
 power output, 2.329  
 primers, 2.359  
 Q3D analysis, 2.48  
 radial thrust, 2.372  
 recirculation, 2.369–2.370  
     recirculating flow, 2.19  
 return passages, 2.45  
 rotary pump comparisons, 3.130  
 rotative speed, 2.27  
 Rüttschi formula, 2.384  
 scaling, 2.19  
 second law of  
     thermodynamics, 2.10  
 shrouds, profiles, 2.31–2.33, 2.62  
 similitude, 2.20  
 sizing, 2.28–2.29  
     effect on efficiency, 2.24  
 slurry effects, 2.26  
 speeds, rotor shape, 2.23  
 starting, 12.14  
 static instability, 2.56  
 static pressure  
     increases, 2.16  
     losses, 2.14

static stability, 2.56  
 stopping, 12.14  
 subscript designations, 2.8  
 suction nozzles, 2.58  
 suction recirculation, 2.370  
 suction throttling, 2.366  
 suction-specific speed, 2.352  
 temperature rise, 2.372  
 Thoma cavitation parameter, 2.352  
 total dynamic head, 2.10  
 transient operations, 2.379–2.381  
 transient power failures, 2.376  
 troubleshooting, 12.20–12.23  
 turbine applications, 2.385–2.387  
 underfiling vanes, 2.343  
 units, 2.327  
 vane tips  
     clearance, 2.337  
     reducing size, 2.342  
 vaned diffusers, 2.43–2.44  
 velocity diagrams, 2.13  
 velocity triangles, 2.19  
 vibration, 2.382  
 viscosity, 2.25  
 volumetric efficiency, 2.334  
 volutes, 2.41–2.43, 2.67  
 wearing rings, clearance, 2.336  
 centrifugal slurry pumps,  
     9.351–9.352, 9.358  
     casings, 9.357  
     efficiencies, 9.360–9.361  
     hydraulic design, 9.353  
     impellers, 9.357  
     liners, 9.365  
     particle impact wear, 9.364  
     seals, 9.357  
     shells, 9.365  
     sliding abrasion wear, 9.364  
     solids effects, 9.360  
     wear, 9.353, 9.363–9.365  
 centrifugal/displacement systems,  
     flow control, 3.78, 3.81  
 ceramic pumps, 5.53  
 CFD (computational fluid dynamics),  
     centrifugal pumps, 2.46,  
     2.51–2.52  
 chamber design, seals, 2.220  
 charging pumps, 9.280

- check valves
  - AODPs, 3.93
  - sealing liquids, 2.143
  - waterhammer, 8.98, 8.102
- chemical pulping, 9.160
- chemical pumps
  - alkaline solutions, 9.117
  - casting integrity, 9.121
  - chlorine, 9.117
  - corrosion, 9.118
  - gaskets, 9.121
  - hydrochloric acid, 9.117
  - maintenance, 9.122
  - materials of construction, 9.115–9.116, 9.121
  - nitric acid, 9.117
  - nonmetallic, 9.124
  - organic acids/compounds, 9.117–9.118
  - packings, 9.122
  - phosphoric acid, 9.117
  - pigments, 9.116
  - power end, 9.122
  - salt solutions, 9.118
  - sealless, 9.124
  - seals, 9.122–9.123
  - shafts, 9.123
  - sulfuric acid, 9.116
  - types, 9.120
  - weldments, 9.121
- chemical resistance, composite pumps, 5.51
- chemical transfer systems. *See* transfer systems.
- chilled water pumps, PWR plants, 9.283
- chlorine
  - chemical pumps, 9.117
  - composite pump applications, 5.54
  - corrosion, 5.38
  - paper mill pumps, 9.165
- chrome plating, shafts, 5.30
- Cipoletti weirs, 13.19, 13.22
- circuits, hot water pumps, 9.255
- city water cooling systems, engines, 6.66
- clamshell markings, 5.24
- classes of nuclear pumps, 9.294
- classification of pumps, 1.2–1.3
- clearances
  - centrifugal pumps, 2.336–2.337
  - magnetic bearing rotors, 2.282
  - wearing rings, 2.123–2.124
- clockwise rotation, 2.107
- closed cooling water pumps, BWR plants, 9.284
- closed cooling electric motors, 6.20
- closed couplings, sealless magnetic drive pumps, 2.305
- closed cycles, steam power plants, 9.75
- closed impellers, 2.115
- closed loop branch-line pumping systems, 8.83–8.84
- closed-cycle gas turbines, 6.90
- closed-loop controls, 7.3
- coagulant feed pumps, water treatment plants, 9.16
- coatings, 5.7, 5.44
- codes, fire protection systems, 9.60
- coefficient of friction
  - packings, 2.187
  - seals, 2.202
- cold alignment of pump and driver, 2.413
- collectors, centrifugal pumps, 2.41
- Colmonoy-wear rings, 5.32
- combined cycle gas turbines, 6.90
- combined displacement/centrifugal systems
  - flow control, 3.78
  - parallel operation, 3.81
  - suction boost, 3.81
- commercial purchase recommendations, 11.29
- commercial terms, RFQs, 11.9
- commercial water usage, 9.5
- complex slurry flows, 9.338–9.339
- component cooling water pumps, 9.280
- component efficiencies, centrifugal pumps, 2.11–2.12
- composite pumps
  - abrasives, 5.50
  - bedplates, 5.61
  - chemical resistance, 5.51

- chlorine applications, 5.54
- dye applications, 5.57
- ethylene uses, 5.57
- ferric chloride uses, 5.57
- industrial uses, 5.58
- insulation properties, 5.50
- lined housings, 5.53
- materials of construction, 5.60
- mechanical properties,
  - 5.49–5.50, 5.54
- operating temperatures, 5.50
- propylene uses, 5.57
- standards, 5.60
- sulfuric acid applications, 5.57
- thermoplastic, 5.51
- thermoset, 5.52
- UV exposure, 5.50
- compound pressure gages, 12.12
- compressible flow, jet pumps, 4.8
- compression packings,
  - 2.183–2.184, 2.187
- computer-based pump systems
  - design, 11.33
- computer-based purchase proposals,
  - 11.30–11.31
- concentrated sludge/scum pumps,
  - 9.34–9.35
- concentration cell corrosion,
  - chemical pumps, 9.118
- concentrations, solutions,
  - 9.113–9.114
- condensate injection water,
  - requirements, 2.241
- condensate pumps, 9.96
  - bypass control, 9.102
  - discharge throttling, 9.102
  - flow regulation, 9.100
  - marine plants, 9.220–9.223
  - seal cages, 9.99
- condenser circulating pumps, 9.104
  - performance, 9.105
  - system hydraulics, 9.108
- condenser exhausting pumps, 9.223
- conduction rings, sealless magnetic drive pumps, 2.298
- connecting rods, power pumps, 3.31
- Conrad-type bearings, 2.151
- consistency, paper stock, 9.166
- constant altitude performance,
  - aircraft fuel pumps, 9.416
- constant differential pressure
  - propulsion marine pumps, 9.220
- constant drain temperature-controlled injection flow control systems, 2.243
- constant pressure governors,
  - propulsion marine pumps, 9.219
- constant speed control systems, 7.9
- constant speed multipump
  - water pressure booster systems, 9.454
- constant-torque loads, eddy current couplings, 6.103
- constituents of solutions, 9.113
- construction refinery pumps,
  - 9.134, 9.137
- construction liquids transfer systems, 9.444
- contact load solids, 9.322
- contact secondary controls, wound-rotor induction motors, 6.116
- contacting liquid lubricated seals,
  - 2.197–2.199, 2.215
- contacting seals, operating envelope, 2.207
- containment shell, sealless magnetic drive pumps, 2.305
- containment spray pumps, PWR plants, 9.280
- contaminated fuels, aircraft fuel pumps, 9.429
- contamination, cylindrical bearings, 2.255
- continuous bypass systems, 2.441
- continuous coil packings, 2.193
- continuous-tooth herringbone gears, 6.146
- control panels, water pressure booster systems, 9.455
- control rod drive pumps, BWR plants, 9.284
- control systems, 7.2
  - adjustable-speed belt drives, 6.173
  - alternators, 7.7



- boiler feedwater constant speed, 7.11–7.13
- building water pressure, 7.14
- bypass systems, 2.450
- closed-loop controls, 7.3
- constant speed, 7.9
- eddy current couplings, 6.105
- gas turbines, 6.94
- liquid level sensors, 7.4
- on-off constant speed, 7.9
- on-off controls, 7.3
- open-loop controls, 7.3
- pressure sensors, 7.7
- proportional controls, 7.3
- sewage systems, 9.40
- steam turbines, 6.41
- system design, 11.4
- telemetry systems, 7.9
- transducers, 7.7
- transmitters, 7.7
- valve-throttling constant speed, 7.10
- valves, 7.14–7.15
- waterhammer prevention, 8.103–8.105
- control techniques for noise, 8.113
  - airborne noise, 8.117–8.122
  - controlling noise paths, 8.115–8.116
  - source modification, 8.113–8.114
- control valves, 7.15, 7.23
  - ball valves, 7.16
  - butterfly valves, 7.16
  - cage valves, 7.16–7.17
  - cavitation, 7.23
  - flow characteristics, 7.20–7.21
  - flow coefficient, 7.22
  - gain, 7.21
  - gate valves, 7.16
  - globe valves, 7.15
  - injection flow systems, 2.245
  - multiple orifices in series, 7.18
  - positioners, 7.26
  - pressure recovery, 7.23
  - rangeability, 7.21
- controlled valve closure, waterhammer, 8.100
- controllers
  - fire protection systems, 9.61
  - fluid couplings, 6.139
- controlling noise path, noise control, 8.115–8.116
- controls. *See* control systems.
- conventional generation, pumped storage, 9.268
- conventional sewage pumps, 9.29
- conventional split-shaft gas turbines, 6.90
- coolant flow, seals, 2.204–2.205
- cooling systems, engines, 6.62–6.66
- cooling tower systems, 9.257–9.258
  - engines, 6.68
  - intakes, 10.8
  - pump pits, 10.6
- cooling water intakes, 10.5
- copper oxide corrosion, 5.4
- corrective fatigue measures, 5.25
- corrective procedures for common problems, 2.404
- corrosion, 5.37
  - alloys, 5.7
  - cavitation erosion, 5.11
  - chemical pumps, 9.118
    - seals, 9.122
    - shafts, 9.123
  - copper oxide corrosion, 5.4
  - dealloying, 5.5
  - dezincification, 5.5
  - galvanic corrosion, 5.6–5.7
  - graphite corrosion, 5.4–5.5
  - hydrocarbons, 5.38
  - intergranular, 5.10
  - microbiologically-induced, 5.10
  - rotary pumps, 3.136
  - stress corrosion cracking, 5.7
- corrosion-assisted fatigue, 5.25
- cost estimates, pumped storage, 9.275
- counterbalance, oil well pumps, 9.386
- counterclockwise rotation, 2.107
- couplings
  - balance, 6.182
  - elastomer, 6.178–6.179
  - electric motors, 6.20

flexible, 6.176  
flexible diaphragm, 6.178  
gear units, 6.160  
limited end float, 6.182  
material flexible, 6.178  
mechanically flexible, 6.176–6.177  
metal disk, 6.178  
rigid, 6.175–6.176  
rubber jaw, 6.179  
spring-grid, 6.180  
vertical operations, 6.182  
crack arrest lines, 5.24  
cracking and fatigue, 5.22–5.23  
crank pin bearings, power pumps, 3.33  
cranking ratios, engines, 6.71  
crankshafts, power pumps, 3.28–3.29  
crevice corrosion, chemical pumps, 9.118  
critical damping, seismic nuclear pumps, 9.302  
critical mass  
bearings, 2.270  
journal bearings, 2.271  
critical sigma, turbines, 6.83  
critical speed  
centrifugal pumps, 2.409  
shafts, 2.132–2.133, 6.187  
cross coupling, bearings or springs, 2.267  
crossheads, power pumps, 3.32  
crossways, power pumps, 3.32  
crude oil pipeline service, gas turbines, 6.95  
cryogenic liquids, 2.227  
cryogenic pumps, 9.399  
atmospheric gases, 9.400  
LNG (liquefied natural gas), 9.403–9.405  
LPG (liquefied petroleum gas), 9.404–9.405  
refueling systems, 9.401  
ship-loading, 9.405  
CTIO volume (closed-to-inlet-and-outlet), rotary pumps, 3.123  
current meters, 13.26  
Curtis stage steam turbines, 6.46

cushion valves, duplex steam pumps, 3.44  
cycle time, sewage systems, 9.38  
cyclone separators, 2.142  
cylinders  
engines, 6.57  
power pumps, 3.22  
liners, 3.26  
cylindrical bearings, 2.254  
performance plots, 2.259  
spring and damping coefficients, 2.268  
with axial grooves, 2.255

## D

daily observation of pump operations, 12.16  
dam wearing rings, 2.120  
damping coefficients, 2.267  
Darcy-Weisbach formula, 8.33  
data sheets, RFQs, 11.11  
datum, horizontal/vertical shaft pumps, 2.328  
DC motors, 6.3, 6.8  
PM brushless, 6.10, 6.12  
SCR power supply drives, 6.123  
shunt-wound, 6.8  
SR brushless, 6.13  
dealloying, 5.5  
dealuminification, 5.6  
debris removal, 10.14–10.16  
deep well eductors, 4.38  
deep well marine cargo pumps, 9.242–9.243  
deep well turbine irrigation pumps, 9.46  
defective bearings, 2.406  
deflection, shafts, 2.134  
deformation rates, 8.32  
degrees of freedom, seismic nuclear pumps, 9.302  
delivery, screw pumps, 3.101, 3.115

- demand profiles, water pressure
  - booster systems, 9.457–9.460
- deposition, partially stratified
  - slurries, 9.332
- derating power pumps, 3.9
- design/analysis computer programs, 11.33–11.34
- designing intakes, 10.42
  - approach channel, 10.46
  - Froude scaling, 10.45
  - model scale, 10.46
  - model similitude, 10.44
  - screens, 10.47
- designing magnetic bearings, 2.285
- designing pumps, 10.47
  - centrifugal, 2.27
    - faults, 2.406
  - control systems, 11.4
  - flow distribution, 10.51
  - fluid characteristics, 11.2, 11.7
  - free surface vortices, 10.49
  - gas turbine temperatures, 6.91
  - intake loss coefficient, 10.50
  - nuclear pumps, 9.293–9.294
  - operating modes, 11.3
  - power, 3.21–3.22
  - prerotation, 10.50
  - pump type selection, 11.4, 11.7
  - subsurface vortices, 10.49
  - system head curves, 11.2–11.3
- designing slurry transport
  - systems, 9.343
    - homogeneous slurries, 9.344–9.345
    - settling slurries, 9.345
- detailed dynamic analysis, seismic
  - nuclear pumps, 9.308
- dezincification, 5.5
- diagnostics
  - canned motor pumps, 2.322
  - displacement pumps, 3.70–3.71
  - magnetic bearings, 2.291
  - vibration symptoms, 2.425, 2.430–2.431
- dial indicators
  - pump alignment, 12.4
  - pump installs, 2.418
- diaphragm couplings, 6.178
- diaphragm pumps
  - air-operated, 3.92–3.93
  - chemical, 9.121
  - hydraulically driven, 3.89–3.91
  - mechanically driven, 3.85–3.86
    - walking beams, 3.87
- diaphragms, 2.108
- diesel engines, 6.57
  - fire protection systems, 9.60
  - fuel systems, 6.62
- diesel freshwater cooling
  - pumps, 9.226
- diesel generators
  - fuel oil pumps, 9.229
  - jacket water circulating
    - pumps, 9.229
    - lubricating oil pumps, 9.229
- diesel marine pumps, 9.226
- diesel seawater cooling pumps, 9.226
- diesel transfer systems, 9.443
- differential mercury gages,
  - measuring head, 13.34
- differential pressure
  - rotary pumps, 3.145
  - water supply systems, 9.12
- differential pressure meters, 13.15
- differential pressure-controlled
  - injection flow systems, 2.242
- differential temperature-controlled
  - injection flow systems, 2.242
- diffusers
  - centrifugal pumps, 2.43–2.44
  - pumps, 2.97, 2.100, 2.163
- diffusion effects, centrifugal
  - impellers, 2.15, 2.66
- digester circulating paper mill
  - pumps, 9.181
- dilatant liquids, 8.33, 9.188
- dilute sludge pumps, 9.34
- direct acting steam pumps, 3.40, 3.53
- direct connected steam
  - turbines, 6.39
- direct-acting pumps, throttle
  - control, 3.75
- direct-connected exciters,
  - synchronous motors, 6.7
- disc diaphragm pumps, 3.89

- discharge
  - drainage/irrigation systems, 9.48–9.51
  - mainfolds, power pumps, 3.27
  - pressure, 2.439
  - steam power plants, 9.85
  - recirculation, 2.370, 2.398
  - testing pumps, 13.14
- discharge head, 13.4
- discharge nozzles, 2.106
- discharge piping, 12.9
  - float mounted mining pumps, 9.202–9.203
  - profiles, waterhammer, 8.93
  - water supply systems, 9.9
- discharge stroke, reciprocating pumps, 3.38
- discharge throttling
  - centrifugal pumps, 2.366
  - condensate pumps, 9.102
- discharge valves, power pumps, 3.27
- disks, hydroviscous drives, 6.134
- displacement
  - power pumps, 3.4
  - rotary pumps, 3.138, 3.141–3.143
  - steam pumps, 3.53
- displacement pumps, 1.3
  - acoustic filters, 3.68
  - bypass control, 3.78
  - diagnostics, 3.70–3.71
  - flow control, 3.75
    - operating costs, 3.78
    - pumps in series, 3.83
  - gas-charged dampeners, 3.69
  - in-line gas dampeners, 3.69
  - inadequate NPSH, 3.63
  - isentropic bulk moduli, 3.66–3.67
  - isothermal bulk moduli, 3.67
  - piping system
    - acoustic velocities, 3.64–3.65
    - pulsation responses, 3.64
    - vibration, 3.70
  - positive pulsations, 3.64
  - pulsation control, 3.67
  - shaft failures, 3.73
  - side branch accumulators, 3.69
  - speed changer controls, 3.76
  - suction valve unloading, 3.76–3.77
  - thermal problems, 3.72
  - troubleshooting, 3.63
- displacement/centrifugal systems,
  - flow control, 3.78, 3.81
- dissolved air issues, screw pumps, 3.113
- dissolved gases, rotary pumps, 3.134
- distance shaft sleeves, 2.136
- distillation marine pumps, 9.234
- distribution pumps, water treatment plants, 9.19
- domestic water usage, 9.5
- double acting reciprocating pumps, 3.38
- double helical gears, 6.146
- double seals, 2.208
- double volute pumps, 2.101
- double-end screw pumps, 3.104
- double-ring pumps, 2.119
- double-row angular contact ball bearings, 2.152
- double-suction impellers, 2.113, 2.124
- doughnut type pumps, 2.110
- doweling, pumps/drivers, 12.8
- drain lines, injection flow systems, 2.245
- drain pockets, baseplates, 2.156
- drainage pumps, 9.45
  - capacities, 9.48
  - discharge systems, 9.49–9.51
  - multiple pumps, 9.47
  - pool-to-pool head, 9.48
  - propeller, 9.53
  - total suction head, 9.52
  - total suction lift, 9.52
  - turbines, 9.52
  - valves, 9.48
  - volute, 9.52
- drains, piping systems, 12.11
- dredge pumps, 9.321, 9.351
- drive shaft systems, 6.182–6.183
- drive-end pumps, 2.107
- driver speed controls, displacement pumps, 3.76
- drivers
  - boiler feed pumps, 9.90

- centrifugal pumps, torque
    - characteristics, 2.359–2.360
  - doweling, 12.8
  - fire protection systems, 9.60
  - mining pumps, 9.212
  - refinery pumps, 9.142
  - selecting, 11.8
  - sewage systems, 9.39
  - steam power plants, 9.85–9.87
  - water supply systems, 9.10
  - dry pit pumps, 2.99
    - multipump systems, 10.11–10.12
    - sewage pumps, 9.29
  - dry running, sealless magnetic
    - drive pumps, 2.310
  - dry vacuum pumps, 2.458
  - dual containment shells, sealless
    - magnetic drive pumps, 2.308
  - dual strainers, injection flow
    - systems, 2.245
  - dual-pressurized gas lubricated
    - seals, 2.223–2.224
  - ductile overload zones, 5.24
  - duplex stainless steel
    - casings, 5.29
    - impellers, 5.28
  - duplex steam pumps, 3.40–3.44
  - duty cycles, engines, 6.59
  - dye applications, composite
    - pumps, 5.57
  - dynamic instability, centrifugal
    - pumps, 2.56
  - dynamic pumps, 1.3
  - dynamic viscosities, 8.32
- E**
- ebullition cooling systems,
    - engines, 6.67
  - eccentric straps, power pumps, 3.31
  - ECCS (emergency core cooling
    - system), PWR plants, 9.280
  - economic evaluation, pumped
    - storage, 9.272
  - eddies, 10.24
  - eddy current couplings, 6.99
    - air-cooled, 6.105
    - applications, 6.106
    - constant-torque loads, 6.103
    - control systems, 6.105
    - enclosures, 6.105
    - horizontal, 6.103
    - ratings, 6.106
    - sizes, 6.106
    - slip speed, 6.100–6.101
    - variable-torque loads, 6.101
    - vertical, 6.104
    - water-cooled, 6.105
    - weather-protected, 6.105
  - eddy current losses, sealless
    - magnetic drive pumps,
      - 2.306–2.307
  - eductors, 4.24–4.25
    - air lift, 4.47
    - applications, 4.30
    - deep well, 4.38
    - general purpose, 4.30–4.32
    - mixing, 4.33
    - multinozzle, 4.38
    - NPSH, 4.27
    - performance, 4.30
    - priming, 4.41
    - sand/mud, 4.36
    - solids handling, 4.37
    - spindle proportioning, 4.34
  - efficiencies
    - boiler feed pumps, 9.94–9.95
    - centrifugal pumps, 2.60–2.61,
      - 2.329, 2.334, 2.382–2.383
    - eddy current couplings, 6.101
    - electric motors, 6.4, 6.25
    - fluid couplings, 6.139
    - gear reducers, 6.153
    - paper mill pumps, 9.180–9.181
    - power transmission systems, 6.197
    - single-stage steam turbines, 6.47
    - slurry pumps, 9.360–9.361
    - steam power plants, 9.94–9.95
    - steam turbines, 6.48
      - units of measure, 13.7
  - efficiency formula, 13.37
  - ejectors, 2.458, 4.23
  - elastomer couplings, 6.178–6.179

- elastomeric vane pumps. *See* flexible liner pumps.
- electric drives, 6.109–6.111
- electric motors
  - AC, 6.3
  - acceleration, 6.23–6.24
  - adjustable-frequency drives, 6.118
  - ball bearings, 6.17
  - bearings, 6.17
  - brushless synchronous motors, 6.7
  - DC, 6.3, 6.8
    - with SCR power supply drives, 6.123
  - drainage/irrigation, 9.53
  - efficiencies, 6.4, 6.25
  - enclosures, 6.15–6.16
  - fire protection systems, 9.60
  - flanged, 6.20
  - flux vector drives, 6.121
  - frequency variations, 6.22
  - horizontal wound-rotor induction, 6.114
  - hydrodynamic bearings, 6.18
  - insulation, 6.18–6.19
  - Kraemer drives, 6.122
  - magnetic starters, 6.27
  - manual starters, 6.27
  - mining pumps, 9.212
  - motion equations, 6.23
  - performance, 6.21
  - power factors, 6.26
  - pull-in torque, 6.25
  - pump coupling methods, 6.20
  - rolling element bearings, 6.18
  - safe temperature, 6.25
  - service factor ratings, 6.25
  - sleeve bearings, 6.18
  - speeds, 6.23
  - squirrel-cage induction motors, 6.4–6.5
  - starters, 6.27–6.28
  - submersible centrifugal oil well pumps, 9.393
  - submersible pumps, 9.246
  - synchronous motors, 6.6
  - TEWAC (totally enclosed water-to-air-cooled), 6.113
  - voltage ratings, 6.22
  - wound-rotor induction, 6.111–6.113
  - wound-rotor induction motors, 6.5–6.6
- electric starters for engines, 6.71
- electromagnetic effects, centrifugal pumps, 2.27
- electronic pumps, 3.87–3.88
- elevation head
  - centrifugal pumps, 2.10
  - pumping systems, 8.6
- elliptical bearings, 2.255
- emergency pumps, fire protection systems, 9.58
- emissions, gas turbines, 6.93
- emulsions, centrifugal pumps, 2.27
- enclosures
  - eddy current couplings, 6.105
  - electric motors, 6.15–6.16
- end plates, rotary pumps, 3.124
- end suction pumps, 2.102, 9.58
- energy conversion, steam turbines, 6.46
- energy evaluations, RFQs, 11.11
- energy gradients, pumping systems, 8.12
- energy level measurements, high-energy pumps, 2.71
- energy transfer, centrifugal pumps, 2.9
- engineering guidelines, fire protection systems, 9.62
- engines
  - air cleaners, 6.69
  - air intake systems, 6.68
  - alignment, 6.74
  - cooling systems, 6.62–6.68
  - cylinders, 6.57
  - drainage/irrigation, 9.53
  - duty cycles, 6.59
  - exhaust systems, 6.60, 6.70
  - foundations, 6.73
  - fuel systems, 6.61
  - heat exchangers, 6.66
  - ignition systems, 6.72
  - maintenance, 6.60

mufflers, 6.70  
 pistons, velocities, 6.59  
 pollutants, 6.60  
 power ratings, 6.57–6.58  
 radiators, 6.64–6.65  
 speed ratings, 6.60  
 starters, 6.70–6.71  
 vibration isolation, 6.74  
 entrained air  
   centrifugal pumps, 2.358  
   rotary pumps, 3.134  
   screw pumps, 3.113  
 entrained gases, centrifugal  
   pumps, 2.26  
 environmental issues  
   canned pump bearings, 2.321  
   environmentally-assisted  
     fatigue, 5.22  
   gas turbines, 6.91  
 epicyclic gear units, 6.159  
 equations  
   liquid jet pumps, 4.7  
   LJL pumps, 4.9–4.10  
 equipment inspection, 12.16–12.17  
 equivalent fluid slurries, 9.322  
   hydraulic gradient, 9.324  
   pressure losses, 9.323  
 equivalent head, pumping  
   systems, 8.5  
 erosion, 5.17–5.20  
   cavitation, high-energy  
     pumps, 2.88  
   corrosion, 5.37  
     chemical pumps, 9.119  
     high purity water, 5.35  
     saline water, 5.36  
 ethylene uses, composite  
   pumps, 5.57  
 Euler's Pump Equation, 2.13  
 evaluating bids, 11.24  
 exhaust gas boiler marine  
   pumps, 9.231  
 exhaust systems, engines, 6.60, 6.70  
 exit radius, centrifugal pumps, 2.30  
 exit width, centrifugal pumps, 2.30  
 expansion joints, piping  
   systems, 12.10

explosion-proof enclosures, electric  
   motors, 6.16  
 exposure limits for noise, 8.124  
 extended Bernoulli equation, 2.15  
 extended-shaft pumps, power  
   losses, 6.197  
 external gear pumps, 3.127  
 eye of impeller. *See* impeller eye.

## F

face pressure, seals, 2.201  
 face-and-rim alignment, 12.5  
 failures  
   power, 12.16  
   pump motor, waterhammer,  
     8.95–8.96  
 fast fracture zones, 5.24  
 fatigue, 5.22, 5.24  
   corrective measures, 5.25  
   failures, 2.401  
   reducing via mechanical  
     notches, 5.23  
 feedback systems, magnetic  
   bearings, 2.278–2.279  
 feet, casings, 2.110  
 ferric chloride uses, composite  
   pumps, 5.57  
 fertilizer pumps, 9.321, 9.442  
 fiber characteristics of paper  
   stock, 9.166  
 field maintenance, 12.2  
 field tests, 13.2  
 filters  
   canned motor pump  
     assemblies, 2.318  
   gas turbines, inlets, 6.94  
   injection flow systems, 2.245  
 finite element method analysis,  
   seismic nuclear pumps, 9.303  
 fire marine pumps, 9.231–9.232  
 fire protection systems, 9.57  
   accessories, 9.70  
   codes and regulations, 9.60  
   controllers, 9.61

- drivers, 9.60
- emergency pumps, 9.58
- engineering guidelines, 9.62
- first intervention pumps, 9.58
- jockey pumps, 9.58
- recommended design features, 9.63–9.68
- firm capacity, raw sewage pumps, 9.29
- first intervention pumps, fire protection systems, 9.58
- first law of thermodynamics, 2.9
- fish, preventing from entering intake, 10.18–10.21
- fittings, frictional losses, 8.54
- fixed blade propeller turbines, 6.79
- fixed displacement hydraulic pumps, fixed water flow, 6.195
- fixed orifices, bypass systems, 2.448
- fixed system heads, pumping systems, 8.13
- fixed water flow, hydraulic pumps, 6.195
- flame hardening gears, 6.150
- flanges, 2.110
  - motors, 6.20
  - rigid couplings, 6.175
- flap valves, AODPs, 3.92
- flash distilling marine pumps, 9.234
- flashing, 2.448, 8.113
- flat characteristic, 2.334
- flat side valves, duplex steam pumps, 3.43
- flat wearing rings, 2.119
- flexible couplings, 6.176, 6.181–6.182
- flexible diaphragm couplings, 6.178
- flexible drive shafts, 6.186
- flexible graphite packing, 2.188
- flexible impeller food/beverage pumps, 9.190
- flexible liner pumps, 3.126
- flexible pipe, bedplate issues, 2.157
- flexible shafts, 2.133
- float mounted mining pumps, 9.201–9.203
- floating packings, 2.183
- floating rings, segmented throttle bushings, 2.240–2.241
- floating shafts, 6.184
- flooded suction, units of measure, 13.3
- floor acceleration, seismic nuclear pumps, 9.303
- flow characteristics
  - complex slurries, 9.338–9.339
  - control valves, 7.20–7.21
  - fully stratified slurries, 9.335
  - inclined slurries, 9.342
  - slurries, 9.322–9.323
  - vertical slurries, 9.341
- flow coefficients, valves, 7.22, 8.56–8.58, 8.62–8.63
- flow control, 2.437
  - automatic bypass systems, 2.441–2.443
  - branch-line pumping systems, 8.88
  - combined displacement/centrifugal systems, 3.78, 3.81
  - continuous bypass systems, 2.441
  - control loop bypass systems, 2.442
  - design factors, 2.439
  - displacement pumps, 3.75, 3.78 in series, 3.83
  - sewage systems, 9.41
- flow curves, rotary pumps, 3.131
- flow cutoff, LJGL pumps, 4.8
- flow distribution, scale models, 10.51
- flow metering devices, 12.12
- flow nozzles, testing pumps, 13.16
- flow paths
  - canned motor pumps, 2.318
  - sealless magnetic drive pumps, 2.311
- flow rates, 2.327
  - centrifugal pumps, 2.351, 2.365
  - reducing to prevent cavitation, LJL pumps, 4.17
  - temperature variations, 8.77
- flow regimes, jet pumps, 4.5–4.6
- flow regulation, condensate pumps, 9.100
- flow requirements, 2.438
- flow units, hydraulic turbines, 6.80
- fluid characteristics, pump selection, 11.7



- fluid couplings, 6.127
  - controllers, 6.139
  - efficiencies, 6.139
  - hydrodynamic drives, 6.132
  - hydrokinetic drives, 6.127–6.130
  - hydrostatic drives, 6.134
  - hydroviscous drives, 6.133–6.134
  - leakoff, 6.131
  - output speed regulation, 6.136
  - scoop-trimming, 6.130–6.131
  - turndown, 6.136
- fluid drives. *See* hydrokinetic drives.
- fluid dynamics, 2.9
- fluid film bearing cavitation, 2.248
- fluid friction power losses, rotary pumps, 3.145
- fluid issues, rotary pumps, 3.135
- fluid lubricity, rotary pumps, 3.135
- fluid mechanics, boundary layer theory, 2.249
- fluid vapor pressure, screw pumps, 3.110
- fluid/structure interactions, high-energy pumps, 2.74
- flumes, 13.23–13.24
- fluoride pumps, water treatment plants, 9.17
- flush gland plates, 2.220
- flush-and-quench gland plates, 2.220
- flushes, 2.204
- flushing solids pumps, 9.374
- flux vector drives, 6.121
- flywheel effect, waterhammer, 8.94
- food pumps, 9.187–9.188
  - positive displacement, 9.190
  - rotodynamic, 9.189
  - seals, 9.193
  - types, 9.189–9.190, 9.193
- foot valves, 2.456
- forged cylinders, power pumps, 3.23
- forward curved blades, centrifugal pumps, 2.332
- foul condensate, paper mill pumps, 9.166
- foundations, 12.3, 12.8, 2.155
  - engines, 6.73
  - gear reducers, 6.160
  - grouting, 12.8
  - screw pumps, 3.120
  - vertical pumps, 2.175
- frames, power pumps, 3.28
- Francis turbines
  - power shafts, 6.80
  - runners, 6.79
  - sizes, 6.83
- Francis-vane impellers, 2.113
- Francis-vane radial impellers, 2.113
- free surface vortices, 10.39, 10.49
- freeness, paper stock, 9.166
- frequencies
  - defective bearings, 2.406
  - impeller vane passage, 2.406
  - variations, electric motors, 6.22
  - vibration analysis, 2.419–2.424
- frequency inverters, PWM, 6.118
- freshwater cooling marine pumps, 9.230
- freshwater drain collecting tank pumps, 9.223
- fretting, 5.15
- friction, 8.32
- frictional losses
  - head losses, pumping systems, 8.34, 8.39–8.48
  - journal bearings, 2.253
  - LJL pump coefficients, 4.12
  - paper mill piping, 9.170–9.173, 9.177–9.179
  - water supply systems, 9.12
- Froude scaling of intakes, 10.45
- fuel oil pumps, 9.225–9.229, 9.256
- fuel pool cooling pumps, BWR plants, 9.285
- fuel systems, engines, 6.61
- fuels
  - aircraft fuel pumps, 9.415
  - gas turbines, 6.91
- full-convolution bellows seals, 2.214
- fully stratified slurries, 9.323, 9.335
- fundamental shaft frequency
  - pressure pulsations, 8.105
- fungicide transfer systems, 9.442
- FVNR starters (full voltage nonreversing), wound-rotor induction motors, 6.111

## G

- gain, control valves, 7.21
- galling resistance of alloys, 5.30–5.34
- galvanic corrosion, 5.6–5.7, 9.119
- gaps, sealless magnetic drive pumps, 2.299
- gas turbines, 6.89
  - acoustic treatments, 6.93
  - brake horsepower, 6.96
  - Brayton cycle, 6.89
  - closed-cycle, 6.90
  - combined cycle, 6.90
  - control systems, 6.94
  - design temperatures, 6.91
  - emissions, 6.93
  - environmental issues, 6.91
  - filtration inlets, 6.94
  - fuel oil marine pumps, 9.227
  - fuel sources, 6.91
  - Joule cycle, 6.89
  - lubricating oil marine pumps, 9.227
  - lubrication, 6.94
  - noise, 6.93
  - open-cycle, 6.90
  - pipeline service, 6.95
  - pump applications, 6.94–6.96
  - rolling media filters, 6.94
  - single-shaft, 6.90
  - split shaft, 6.90
  - split-shaft conventional, 6.90
  - standards, 6.91
  - starting systems, 6.94
- gas-charged dampeners, displacement pumps, 3.69
- gaseous fuel systems, engines, 6.61
- gaskets, chemical pumps, 9.121
- gasoline transfer systems, 6.61, 9.443
- gate control valves, 7.16
- gear food/beverage pumps, 9.190
- gear pumps, 3.123, 3.127
- gear reducers, 6.152
  - adjustable-speed belt drives, 6.169
  - alignment, 6.160
  - efficiencies, 6.153
  - foundations, 6.160
  - leveling, 6.160
  - power ranges, 6.153
  - ratios, 6.153
  - speeds, 6.153
- geared steam turbines, 6.39
- gears
  - carburizing, 6.150
  - continuous-tooth herringbone gears, 6.146
  - couplings, 6.160
  - double helical gears, 6.146
  - epicyclic gear units, 6.159
  - flame hardening, 6.150
  - grease lubrication, 6.161
  - helical gears, 6.144–6.146
  - hypoid-bevel gears, 6.148
  - induction hardening, 6.149
  - installing, 6.159
  - lubrication, 6.160–6.161
  - minimizing
    - dimensions, 6.150
    - noise, 6.151
  - nitriding, 6.149
  - oil seals, 6.161
  - packaged gear drives, 6.152
  - parallel-shaft gears, 6.144
  - pump drives, 6.143
  - spiral-bevel gears, 6.147
  - spur gears, 6.144
  - straight-bevel gears, 6.147
  - through hardening, 6.149
  - troubleshooting, 6.161–6.164
  - worm gears, 6.148
  - zero-bevel gears, 6.147
- general corrosion, 5.4
- general purpose eductors, 4.30–4.32
- generator motors, pumped storage, 9.262
- geothermal water, salinity, 5.37
- gerotor pumps, 3.129
- gland plates
  - seals, 2.220
  - stuffing boxes, 2.186
- globe control valves, 7.15

- governors
    - pumped storage systems, 9.270
    - single-stage steam turbines, 6.41
    - steam turbines, 6.41
  - graphite corrosion, 5.4–5.5
  - grease
    - ball bearing lubricant, 2.153
    - gear units, 6.161
    - oil lubricant, 2.152
  - grease seals, sewage pumps, 2.144
  - green liquor, paper mill
    - pumps, 9.164
  - ground acceleration, seismic nuclear
    - pumps, 9.303
  - groundwater
    - salinity, 5.37
    - pumps, 9.3–9.4
    - well pumps, 9.21
  - groundwood pulp, 9.159
  - grouting, 12.8
  - guarded enclosures, electric
    - motors, 6.15
  - GVPs (gas void fractions), screw
    - pumps, 3.118
- ## H
- half-convolution bellows seals, 2.214
  - handholes, casings, 2.107
  - Hazen-Williams formula, 8.34–8.36
  - head
    - area meters, 13.18
    - capacity curves
      - sewage systems, 9.39
      - steam power plants, 9.85
    - centrifugal pumps, 2.328
    - measuring, 13.27–13.28
      - Bourdon gages, 13.35
      - differential mercury gages, 13.34
      - mercury gages, 13.34
      - water gages, 13.33
    - pool-to-pool, drainage/irrigation
      - pumps, 9.48
    - pumping systems, 8.5
    - units of measure, 13.3
  - head losses, 8.64
    - bar racks, 8.73
    - metering systems, 8.66
    - perforated plates, 8.73
    - pumping systems, 8.32
      - pipe frictional losses, 8.34, 8.39, 8.42–8.48
    - screens, 8.70
    - throttling orifices, 8.77
    - wire mesh screens, 8.71
  - heat balancing, bearings,
    - 2.263–2.266
  - heat exchangers, engines, 6.66
  - heat of compression, centrifugal
    - pumps, 2.11
  - heat recovery distillation
    - pumps, 9.235
  - heat removal, seals, 2.203
  - heater drain pumps, 9.103–9.104
  - heating jackets, rotary pumps, 3.125
  - helical gears, 6.144–6.146
  - herbicide transfer systems, 9.442
  - heteropolar magnetic bearings,
    - 2.282, 2.285–2.288
  - high head systems,
    - waterhammer, 8.93
  - high purity water, erosion
    - corrosion, 5.35
  - high specific speed centrifugal
    - pumps, 2.364
  - high viscosity uses, rotary
    - pumps, 3.132
  - high-energy pumps, 2.71–2.72
    - blade-vane combinations, 2.76–2.77
  - cavitation
    - backflow, 2.86
    - erosion, 2.71, 2.88
    - instabilities, 2.87
    - pressure pulsations, 2.87
  - energy level measurements, 2.71
  - fluid/structure interactions, 2.74
  - high-energy domains, 2.72
  - low energy domains, 2.74

- MCSF (minimum continuous stable flow), 2.80, 2.84
- NPSH life prediction, 2.90
- pressure pulsations, 2.71
- recirculation, 2.78–2.79
- suction specific speed, 2.84–2.85
- torque per unit volume, 2.72–2.73
- high-head mining pumps, 9.208
- high-pressure core spray pumps, BWR plants, 9.285
- high-service pumps, water treatment plants, 9.19
- homogeneous slurries, transport systems, 9.344–9.345
- homopolar magnetic bearings, 2.282, 2.289–2.290
- horizontal condensate pumps, 9.96
- horizontal eddy current couplings, 6.103
- horizontal shaft pumps, standard datum, 2.328
- horizontal shafts pumps, 2.99 turbines, 6.80
- horizontal wound-rotor induction motors, 6.114
- horizontally split casings, 2.102
- hot alignment of pump and driver, 2.414
- hot water pumps, 9.253
  - air ventilation, 9.254
  - circulation marine pumps, 9.236
  - types, 9.254–9.255
- housings
  - composite pumps, 5.53
  - hydrokinetic drives, 6.128
  - hydroviscous drives, 6.133
- hubs
  - centrifugal pumps, profiles, 2.31–2.33, 2.62
  - impellers, 2.118
- hybrid bearings, 2.257
- hydraulic balancing devices, 2.129, 2.131
  - balancing disks, 2.130
  - balancing drums, 2.129
  - predetermined thrust direction, 2.130
- hydraulic conditions, mining pumps, 9.207–9.208
- hydraulic couplings. *See* hydrokinetic drives.
- hydraulic design, slurry pumps, 9.353
- hydraulic efficiency, centrifugal pumps, 2.334
- hydraulic geometry, centrifugal pumps, 2.21
- hydraulic gradient
  - equivalent fluid slurries, 9.324
  - non-Newtonian flows, 9.325
  - non-Newtonian slurries, 9.325
  - open channels, 8.41
  - pumping systems, 8.12
- hydraulic horsepower, rotary pumps, 3.145
- hydraulic instabilities, 2.438
- hydraulic presses, 9.463
  - operating pressures, 9.466
  - reciprocating pumps, 9.464–9.465
- hydraulic pumps, power
  - transmission systems, 6.191–6.192
- hydraulic starters, engines, 6.71
- hydraulic submersible centrifugal oil well pumps, 9.395–9.396
- hydraulic system marine pumps, 9.231
- hydraulic transients, pumped storage, 9.263–9.264
- hydraulic turbines, 6.77–6.79
  - cavitation, 6.83
  - flow units, 6.80
  - power shafts, 6.80
  - runners, 6.82
  - torque, 6.86
- hydraulic water pumps
  - applications, 6.193
  - efficiency, 6.197
  - fixed water flow, 6.195

- performance curves, 6.197
- variable water flow, 6.196
- hydraulic-motor-driven submersible pumps, 9.246
- hydraulically actuated diaphragm metering pumps, 9.315
- hydraulically actuated piston metering pumps, 9.315
- hydraulically driven diaphragm pumps, 3.89, 3.91
- hydraulics, 2.9
- hydrocarbons, corrosion, 5.38
- hydrochloric acid chemical pumps, 9.117
- hydrodynamic bearings, 2.135
  - canned motor pumps, 2.317
  - electric motors, 6.18
- hydrodynamic drives, 6.132
  - capacitance, 6.135
  - response speeds, 6.138
- hydrogen embrittlement, 5.9
- hydrokinetic drives, 6.127–6.128
  - bearings, 6.129
  - capacitance, 6.134
  - casings, 6.129
  - housing, 6.128
  - manifolds, 6.130
  - oil coolers, 6.129
  - oil pumps, 6.129
  - response speeds, 6.136
  - rotors, 6.129
  - scoop tubes, 6.129
  - shafts, 6.129
- hydrostatic drives, 6.134
- hydrostatic tests, 2.111
- hydroviscous drives
  - capacitance, 6.136
  - disks, 6.134
  - housing, 6.133
  - oil coolers, 6.134
  - oil pumps, 6.134
  - pistons, 6.134
  - response speeds, 6.138
  - rotors, 6.134
- hypoid-bevel gears, 6.148
- IGBTs (insulated gate bipolar transistors), electric drives, 6.109
- ignition systems, engines, 6.72
- imbalance loads, magnetic bearings, 2.282
- impeller rings, 2.119
  - radial pins, 2.123
  - restricting movement, 2.123
- impellers, 2.97, 2.114
  - axial flow, 2.113
  - axial thrust, 2.124–2.125
  - blades, centrifugal pumps, 2.64
  - centrifugal pumps, 2.29
    - diffusion effects, 2.15
    - increasing speed, 2.334
    - reducing diameter, 2.338–2.339
    - reversed installation, 2.382
  - closed, 2.115
  - double-suction, 2.113
  - eyes, centrifugal pumps, 2.29
  - Francis-vane, 2.113
  - Francis-vane radial, 2.113
  - hubs, 2.118
  - hydraulic unbalance, 2.433
  - inlets, centrifugal pumps, 2.58–2.59
  - inspection ports, 2.120
  - leakage joints, 2.118
  - materials of construction, 5.26–5.27
  - mixed-flow, 2.113
  - open, 2.115
  - opposed, 2.128
  - optimum diameter, 1.5
  - outlets, centrifugal pumps, 2.59
  - overhung, 2.113, 2.118
  - pump-out vanes, 2.115
  - radial vane, 2.113
  - recessed, 2.168
  - semiopen, 2.115
  - single-suction, 2.113

- slurry pumps, 9.357
- straight-vane radial, 2.113
- suction eye, 2.118
- unbalanced, 2.432
- vanes, frequency pressure pulsations, 8.106
- vertical turbine pumps, 2.165
- wearing rings, 2.118
- impulse loads, oil well pumps, 9.383
- impulse stage, steam turbines, 6.39
- impulse turbines, 6.78–6.79
  - runners, 6.79
  - sizes, 6.83
- in-line gas dampeners,
  - displacement pumps, 3.69
- inadequate NPSH, displacement pumps, 3.63
- inboard bearings, 2.149
- inboard-end pumps, 2.107
- inclined flows, slurries, 9.342
- inclined shaft turbines, 6.80
- incorrect driver rotation, centrifugal pumps, 2.382
- index tests, 13.2
- inducers, 2.113–2.114, 2.358
- induction hardening, gears, 6.149
- industrial uses, composite pumps, 5.58
- industrial water usage, 9.5
- inert gas marine pumps, 9.248
- inertial head, pumping systems, 8.22–8.24
- inhibitors, solutions, 9.115
- injection flow systems, 2.241–2.242
  - control valves, 2.245
  - drain lines, 2.245
  - dual strainers, 2.245
  - injection sources, 2.244
- injection-type shaft seals, 2.239–2.240
- injectors, 4.23
- inlet blades, centrifugal pumps, 2.34
- inlet pressure, rotary pumps, 3.134
- inlet vane, vertical turbine pumps, 2.164
- inlet velocity diagrams, centrifugal pumps, 2.64
- inlets, gas turbines, 6.94
- inner magnet encapsulation, sealless magnetic drive pumps, 2.304
- input power, rotary pumps, 3.145
- input speeds, adjustable-speed belt drives, 6.168
- insecticide transfer systems, 9.442
- inserts, slurry pumps, 5.44
- inside-mounted seals, 2.208
- inspecting equipment, 12.16–12.17
- inspection checklists, RFQs, 11.17
- inspection ports, wearing ring clearance, 2.120
- instabilities, high-energy pump cavitation, 2.87
- installing pumps
  - alignment, 12.3, 12.7
  - canned motor pumps, 2.321
  - compound pressure gages, 12.12
  - continuous coil packing, 2.193
  - dial indicators, 2.418
  - discharge piping, 12.9
  - expansion joints, 12.10
  - flow metering devices, 12.12
  - foundations, 12.3
  - gears, 6.159
  - grouting, 12.8
  - magnetic bearings, 2.291
  - relief valves, 12.11
  - rotary pumps, 3.133
  - screw pumps, 3.119
  - suction piping, 12.8
  - suction strainers, 12.10
  - surge chambers, 12.12
  - vents, 12.11
  - warm-up flow piping, 12.11
- installing seals, 2.228
- instrumentation, 12.12, 13.8
- insulation
  - composite pumps, 5.50
  - electric motors, 6.18–6.19
- intakes, 10.3
  - can pumps, 10.26

- cooling tower systems, 10.8
- cooling water, 10.5
- designing, 10.42
  - approach channel, 10.46
  - model scale, 10.46
  - screens, 10.47
- Froude scaling, 10.45
- insufficient NPSH, 10.42
- loss coefficients, scale
  - models, 10.50
- model similitude, 10.44
- once through, 10.5
- prerotation, 10.42
- preventing fish from entry, 10.18–10.21
- similarity of vortices, 10.45
- submergence levels, 10.25
- swirl, 10.42
- velocity caps, 10.18
- vortices, 10.39
- integral eddy current
  - couplings, 6.103
- integral relief valves, rotary
  - pumps, 3.125
- intergranular corrosion, 5.10, 9.119
- interior suction pressure, rotary
  - pumps, 3.144
- intermediate leakoff flow control
  - systems, 2.243–2.244
- intermeshing rings, 2.119
- internal axial velocity limits, screw
  - pumps, 3.109
- internal clearances, canned motor
  - pumps, 2.318
- internal combustion engines.
  - See* engines.
- internal gear pumps, 3.127
- internal static pressure distribution,
  - centrifugal pumps, 2.16
- internal vane pumps, 3.126
- Internet-based vendor
  - communication, 11.35
- interstage diaphragms, 2.108
- interstage passages, multistage
  - pumps, 2.108
- interstage shaft sleeves, 2.136
- irrigation pumps, 9.46
  - capacities, 9.48
  - discharge systems, 9.49–9.51
  - multiple pumps, 9.47
  - pool-to-pool head, 9.48
  - propeller, 9.53
  - total suction head, 9.52
  - total suction lift, 9.52
  - turbines, 9.52
  - valves, 9.48
  - volute, 9.52
- isentropic bulk modulus,
  - displacement pumps, 3.66–3.67
- isothermal bulk modulus,
  - displacement pumps, 3.67

## J–K

- jacket water circulating pumps,
  - diesel generators, 9.229
- jet compressors, 4.23
- jet pumps, 4.23
  - applications, 4.20
  - BWR plants, 9.283
  - compressible flow case
    - solutions, 4.8
  - eductors, 4.24–4.25
    - applications, 4.30
    - NPSH, 4.27
    - performance, 4.30
  - equations, 4.7
  - flow regimes, 4.5–4.6
  - jet losses, 4.8
  - operating conditions, 4.20
  - pump efficiencies, 4.8
  - siphons, 4.43
  - See also* L<sub>JL</sub> jet pumps; L<sub>JG</sub> jet pumps; L<sub>JGL</sub> jet pumps.
- jockey pumps, fire protection
  - systems, 9.58

Joule cycle, gas turbines, 6.89  
 journal bearings  
   critical mass, 2.270–2.271  
   cross coupling, 2.267  
   cylindrical bearings, 2.254  
     with axial grooves, 2.255  
   elliptical bearings, 2.255  
   fluid film bearing cavitation, 2.248  
   heat balancing, 2.263–2.266  
   hybrid bearings, 2.257  
   lobe bearings, 2.255  
   lubrication, 2.248  
   performance plots, 2.259–2.260  
   rotor whirl, 2.266  
   spring coefficients, 2.267  
   stability, 2.270–2.273  
     analyses, 2.268  
   tilted pad bearings, 2.256  
   turbulence, 2.252  
   viscous drag losses, 2.253  
 kinematic viscosities, 8.33  
 Kingsbury-type bearings, electric  
   motors, 6.18  
 Kraemer drives, 6.122

## L

L-type wearing rings, 2.119  
 labyrinth wearing rings, 2.119  
 lake water pumps, 9.259  
 laminar flow, 8.32  
   non-Newtonian slurries, 9.325  
   scaling, 9.329  
 Langelier Index, 5.4  
 lantern rings, 2.186  
   packing, 2.141  
   rotary pumps, 3.124  
   sealing liquids, 2.141  
 lawn services systems, 9.444  
 leaded bronze, impellers, 5.26  
 leading edge lockup, 2.257  
 leakage, 2.207  
   compression packings, 2.187  
   screw pumps, 3.101  
   leakage joints  
   casing cover rings, 2.118  
   casing rings, 2.118  
   impellers, 2.118  
   radial clearance, 2.122  
   relief chambers, 2.119  
   suction head rings, 2.118  
 leakoff fluid drives, 6.131  
 length of mixing throat, L/JL  
   pumps, 4.14  
 level controls, sewage systems, 9.41  
 leveling gear reducers, 6.160  
 leveling pumps, 12.4, 12.7  
 life cycle cost evaluations, RFQs,  
   11.13, 11.15  
 lifetimes of pumps, 5.3  
 lift mechanisms, non-contacting gas  
   lubricated seals, 2.222  
 lime slurries, paper mill  
   pumps, 9.164  
 limited end float, couplings, 6.182  
 limited storage constant speed  
   multipump water booster  
   systems, 9.456  
 limiting stage pressure rise,  
   high-energy pumps, 2.72  
 line bearings, 2.149  
 lined composite pumps, 5.53  
 liners, slurry pumps, 5.44, 9.365  
 liquid cylinders, reciprocating  
   pumps, 3.37  
 liquid end  
   power pumps, 3.22  
   reciprocating pumps, 3.37  
   steam pumps, 3.47  
   diameter, 3.56  
   piston type, 3.47–3.48, 3.51  
   plunger type, 3.53  
   valves, 3.52  
 liquid horsepower, rotary  
   pumps, 3.145  
 liquid jet pumps  
   compressible flow case  
   solutions, 4.8  
   equations, 4.7  
   flow regimes, 4.5–4.6



- jet losses, 4.8
- pump efficiencies, 4.8
- liquid level sensors, 7.4–7.6
- liquid noise sources, 8.110–8.111
- liquid rheostat controls,
  - wound-rotor induction motors, 6.112–6.113
- liquid rocket propellant pumps, 9.431–9.432, 9.437
- liquid viscosity, petroleum pumps, 9.150–9.154
- liquid-plunger separation, power pumps, 3.18
- liquor pumps, paper mills, 9.162
- LJG jet pumps (liquid-jet gas)
  - compressible flow, 4.8
  - flow regime, 4.6
- LJGL jet pumps (liquid-jet gas liquid)
  - compressible flow, 4.8
  - flow regime, 4.6
  - flow cutoff, 4.8
- LJL jet pumps (liquid-jet liquid)
  - area ratios, 4.16
  - cavitation, 4.11
    - limited flow ratios, 4.15, 4.19
  - centrifugal pump interaction, 4.19
  - equations, 4.9–4.10
  - flow performance, 4.15
  - flow ratios, reducing to curb cavitation, 4.17
  - flow regimes, 4.6
  - friction loss coefficients, 4.12
  - longitudinal dimensions, 4.14
  - mixing throats, 4.14
  - nozzle throats, 4.14
  - nozzle to throat area ratio, 4.12
  - operating flow ratio, 4.11
  - primary flow nozzles, 4.14
  - straight line approximation, 4.14
  - throat inlets, 4.15
- LNG cryogenic pumps (liquefied natural gas), 9.404–9.405
- load handling, magnetic bearings, 2.282
- load reduction, boiler feed pumps, 9.79–9.81
- load stress, seismic nuclear pumps, 9.310
- loads, vertical pump foundations, 2.175
- lobe bearings, 2.255, 2.259
- lobe pumps, 3.123, 3.128–3.129
- lobe rotor food/beverage pumps, 9.190
- locating pumps in the field, 12.3
- locks, screw pumps, 3.101
- Lomakin effect, 2.135
- longitudinal dimensions, LJL pumps, 4.14
- losses, centrifugal pumps, 2.11
- low flow protection systems, 2.441
- low flow rates, 2.438
- low head systems,
  - waterhammer, 8.93
- low lift pumps, water treatment plants, 9.16
- low lubricity fuels, aircraft fuel pumps, 9.429
- low specific speed centrifugal pumps, 2.361–2.362
- low-energy domains, high-energy pumps, 2.74
- low-pressure core spray pumps, BWR plants, 9.285
- LPG cryogenic pumps (liquefied petroleum gas), 9.150, 9.404–9.405
- lubricating oil pumps, 9.225
  - diesel generators, 9.229
  - diesel marine pumps, 9.227
  - steam turbogenerators, 9.228
  - transfer marine pumps, 9.230
- lubrication
  - bearings, 2.152
  - gas turbines, 6.94
  - gear units, 6.160–6.161
  - gears, bearings, 6.161
  - journal bearings, 2.248
  - power pumps, 3.34
  - refrigeration pumps, 9.260
  - single-stage steam turbines, 6.41

## M

- magnet blocks, sealless magnetic drive pumps, 2.303
- magnetic bearings, 2.277–2.278
  - active, 2.282
  - backup systems, 2.279
  - catcher bearings, 2.279, 2.284
  - designing, 2.285
  - diagnostics, 2.291
  - feedback systems, 2.278–2.279
  - heteropolar, 2.285–2.288
  - homopolar, 2.289–2.290
  - imbalance loads, 2.282
  - installing, 2.291
  - pump operation, 2.292
  - reduced power consumption, 2.281
  - reliability, 2.281
  - rotors
    - clearances, 2.282
    - dynamics, 2.281–2.283
  - stators, sizing, 2.284
  - transfer function, 2.283
  - transient loads, 2.283
  - tuning, 2.291
  - unit load capabilities, 2.284
  - user interfaces, 2.292
- magnetic drive pumps, 2.179, 2.297
- magnetic starters, electric motors, 6.27
- main bearings, power pumps, 3.33
- main circulating pumps, marine plants, 9.223
- main condensate pumps, marine plants, 9.220–9.223
- main coolant pumps, BWR plants, 9.287, 9.290
- main fuel pumps, aircraft fuel systems, 9.416–9.417, 9.420–9.422, 9.425, 9.427
- maintenance
  - annual inspections, 12.17
  - chemical pumps, 9.122
  - daily observation of pump operation, 12.16
  - engines, 6.60
  - metering pumps, 9.318
  - overhauls, 12.17
  - semiannual inspections, 12.16
  - site location, 12.2
  - solids pumps, 9.376
  - spare parts, 12.19
- manifolds
  - hydrokinetic drives, 6.130
  - power pumps, 3.27
- Manning formula, 8.41
- manual injection flow systems, 2.242
- manual starters, electric motors, 6.27
- marine pumps, 9.215
  - air conditioning chilled water, 9.236
  - ballast pumps, 9.234
  - bilge pumps, 9.232
  - condenser exhausting pumps, 9.223
  - deep well cargo, 9.242–9.243
  - diesel, 9.226
  - electric-motor-driven submersible pumps, 9.246
  - exhaust gas boiler, 9.231
  - fire prevention, 9.231–9.232
  - flash distilling, 9.234
  - freshwater
    - cooling, 9.230
    - drain collecting tank pumps, 9.223
  - fuel oil diesel, 9.225–9.229
  - gas turbine fuel oil, 9.227
  - gas turbine lubricating oil, 9.227
  - heat recovery distillation, 9.235
  - hotwater circulation, 9.236
  - hydraulic system, 9.231
  - hydraulic-motor-driven submersible pumps, 9.246
  - inert gas, 9.248
  - liquid cargo transfer, 9.237–9.238, 9.241
  - lubricating oil diesel, 9.225–9.227
  - lubricating oil transfer, 9.230
  - main circulating pumps, 9.223
  - main condensate pumps, 9.220–9.223
  - potable water, 9.235

- propulsion, 9.216
  - bearings, 9.219
  - constant differential pressure governors, 9.220
  - constant pressure governors, 9.219
  - relief valves, 9.220
  - seals, 9.219
- reciprocating cargo, 9.248
- rotary cargo, 9.248
- sanitary uses, 9.236
- seawater service, 9.230
- sewage, 9.236
- stern-tube lubricating oil, 9.231
- tank cleaning, 9.249
- waste heat, 9.231
- Martensitic stainless steel
  - casings, 5.29
  - impellers, 5.27
  - shafts, 5.30
  - stress corrosion cracking, 5.7
  - wear rings, 5.31
- material flexible couplings, 6.178
- materials of construction, 5.3–5.4
  - casings, 5.28–5.29
  - chemical pumps, 9.115–9.116, 9.121
  - composite pumps, 5.60
  - fire pumps, 9.63–9.68
  - impellers, 5.26–5.27
  - mining pumps, 9.206
  - nuclear pumps, 9.299
  - packings, 2.187–2.188
  - pipeline pumps, 9.145–9.147
  - pump selection, 11.8
  - pumps, 5.32, 5.35
  - refinery pumps, 9.142
  - rotary pumps, 3.125
  - seals, 2.227
  - shafts, 5.29–5.30
  - slurry pumps, 5.43–5.44
  - solids pumps, 9.371
  - steam pumps, 3.45–3.47
  - water pressure booster systems, 9.461
  - wear rings, 5.30
- mating rings, contacting liquid lubricating seals, 2.199
- maximum demand, water supply systems, 9.5
- maximum speed rise, steam turbines, 6.45
- MCSF (minimum continuous stable flow), high-energy pumps, 2.80, 2.84
- measuring elements, 7.4
- measuring noise, 8.122–8.124
- mechanical efficiency
  - centrifugal pumps, 2.50, 2.334
  - power pumps, 3.6, 3.19
  - rotary pumps, 3.146
  - steam pumps, 3.57
- mechanical friction power, rotary pumps, 3.145
- mechanical load, 2.438
- mechanical noise sources, 8.110
- mechanical notches, reducing fatigue, 5.23
- mechanical performance
  - alignment, 2.412–2.417
  - centrifugal pumps, 2.405
  - critical speed, 2.409
  - defective bearings, 2.406
  - multistage boiler feed pumps, 2.410
- mechanical properties, composite pumps, 5.49–5.50, 5.54
- mechanical seals, 2.148
  - chemical pumps, 9.122
  - rotary pumps, 3.124
  - slurry pumps, 9.357
- mechanically actuated diaphragm metering pumps, 9.314
- mechanically driven diaphragms pumps, 3.85–3.87
- mechanically flexible couplings, 6.176–6.177
- medium specific speed centrifugal pumps, 2.364
- mercury gages, measuring head, 13.34
- metal disk couplings, 6.178

- metal-chain belt
  - transmissions, 6.171
- metallic construction materials for pumps, 5.3–5.4
- metallic packing, 2.188
- meter differential pressure, 8.77
- meter loss of head, 8.77
- metering pumps, 9.313
  - calibration, 9.317
  - capacity controls, 9.317
  - hydraulically actuated diaphragm type, 9.315
  - hydraulically actuated piston type, 9.315
  - maintenance, 9.318
  - mechanically actuated diaphragm type, 9.314
  - packed plunger type, 9.313
- microbiologically-induced corrosion, 5.10
- Miller number index, slurry particulate abrasiveness, 5.20
- minimizing gear dimension, 6.150
- minimizing gear noise, 6.151
- minimum flow control systems
  - automatic bypass systems, 2.441–2.443
  - continuous bypass systems, 2.441
  - control loop bypass systems, 2.442
  - design factors, 2.439
  - See also* flow control.
- minimum polished rod load, oil well pumps, 9.384
- minimum pump flow requirements, 2.438
- mining pumps
  - automatic controls, 9.211
  - drivers, 9.212
  - float mounted, 9.201–9.203
  - hydraulic conditions, 9.207–9.208
  - materials of construction, 9.206
  - NPSH, 9.198–9.199
  - pressure pulsations, 9.209
  - pumping conditions, 9.197–9.198
  - sumps, 9.209–9.210
  - system design, 9.205
  - waterhammer analysis, 9.208
- minor losses, pumping systems, 8.53
- mixed-flow impellers, 2.113
  - axial thrust, 2.127
  - centrifugal pumps, reducing diameter, 2.339
- mixing eductors, 4.33
- mixing throats, LJJ pumps, 4.14
- modal analysis, seismic nuclear pumps, 9.303
- model similitude, intake design, 10.44
- model testing, 13.2, 13.39–13.40
  - noise reduction, 8.124
  - suction pits, 10.22
- modeling intakes, 10.42–10.47
- modified Kraemer drives, 6.122
- modulating control systems, 7.2
- moments of forces, centrifugal pumps, 2.13
- Moody-Staufer formula, centrifugal pumps, 2.383
- motion equations, electric motors, 6.23
- motor sheaves, 6.171
- motor speeds, aircraft fuel pumps, 9.414
- motor-driven pumps, 3.87
- motor-generated exciters, synchronous motors, 6.7
- motors
  - electric. *See* electric motors.
  - failures due to waterhammer, 8.95–8.96
- mounting wearing rings, 2.122
- mud eductors, 4.36
- mufflers, engines, 6.70
- multinozzle eductors, 4.38
- multiphase uses, screw pumps, 3.117
- multiple consecutive pumps, 2.107
- multiple orifice in series control valves, 7.18
- multiple origin high cycle fatigue, 5.25
- multiple pump systems, total head, 8.16

multiple screw pumps, 3.99  
 multiple seals, 2.208  
 multiple spring seals, 2.211  
 multiple-convolution bellows  
   seals, 2.214  
 multipump systems  
   dry pit, 10.11–10.12  
   piping, 10.30  
 multistage boiler feed  
   pumps, mechanical  
   performance, 2.410  
 multistage pumps, 2.99  
   axial thrust, 2.128  
   casings, 2.107, 2.110  
   interstage passages, 2.108  
   steam turbines, 6.39, 6.47

## N

Natural frequencies, seismic nuclear  
   pumps, 9.304, 9.308  
 Net inlet pressure, rotary  
   pumps, 3.145  
 Net plunger stroke, oil well  
   pumps, 9.385  
 Newtonian liquids, 8.33  
 Ni-Resist iron, casings, 5.29  
 Nitric acid chemical pumps, 9.117  
 Nitriding gears, 6.149  
 Nitronic alloys, wear rings, 5.32  
 Noise, 8.109  
   cavitation, 8.111–8.113  
   control techniques  
     airborne noise, 8.117–8.122  
     controlling noise paths,  
       8.115–8.116  
     source modification, 8.113–8.114  
   exposure limits, 8.124  
   flashing, 8.113  
   gas turbines, 6.93  
   gears, 6.151  
   liquid sources, 8.111  
   measuring, 8.122–8.124  
   mechanical sources, 8.110  
   rotary pumps, 3.134  
   screw pumps, 3.120  
 Noise data sheets, RFQs,  
   11.19–11.20  
 Non-asbestos packing, 2.188  
 Non-contacting gas lubricated  
   cryogenic seals, 2.227  
 Non-contacting gas lubricated seals,  
   2.198, 2.221–2.222  
 Non-drive-end pumps, 2.107  
 Non-Newtonian flows  
   hydraulic gradient, 9.325  
   rheograms, 9.326  
   turbulent flows, 9.327  
 Non-Newtonian fluids  
   rotary pumps, 3.136  
   screw pumps, 3.113–3.114  
 Non-Newtonian slurries  
   hydraulic gradient, 9.325  
   laminar flow, 9.325  
 Non-recirculating flows, centrifugal  
   pumps, 2.46  
 Nonaerated solutions, 9.114  
 Nonclog sewage pumps, 9.29  
 Nonmetallic chemical pumps, 9.124  
 Nonpusher seals, 2.214  
 Nonreverse ratchets, waterhammer  
   prevention, 8.102  
 Nonseismic nuclear pumps, 9.301  
 Nozzle rings, 2.119  
 Nozzle throats, LJL pumps, 4.14  
 Nozzle to throat area ratio, LJL  
   pumps, 4.12  
 Nozzles, 2.106  
 NPSH (net positive suction head),  
   2.16–2.17, 2.224, 3.111  
   boiler feed pumps, steam power  
   plants, 9.78–9.79  
   centrifugal pumps, 2.25,  
   2.349–2.351, 2.355  
   displacement pumps,  
   inadequacies, 3.63  
   eductors, 4.27  
   high-energy pumps, life  
   prediction, 2.90

- losses, 10.42
- mining pumps, 9.198–9.199
- pipng losses, 10.30
- screw pumps, 3.110–3.112
- units of measure, 13.5
- water supply systems, 9.12
- NPSHA (Net positive suction head available), 3.63, 2.397
- NPSHR (NPSH required), 2.398
- Nuclear pumps, 9.279
  - classes, 9.294
  - design issues, 9.293–9.294
  - materials of construction, 9.299
  - nonseismic, 9.301
  - SSEs (safe shutdown earthquakes), 9.301, 9.306
  - types, 9.291
  - working pressures, 9.87

## O

- O rings, sleeves, 2.138
- ocean inlets, once through intakes, 10.5
- oil
  - ball bearing lubricant, 2.153
  - bearing lubricant, 2.152
  - field brines and salinity, 5.37
- oil coolers
  - hydrokinetic drives, 6.129
  - hydroviscous drives, 6.134
- oil pumps
  - hydraulic presses, 9.464
  - hydrokinetic drives, 6.129
  - hydroviscous drives, 6.134
- oil seals
  - gear units, 6.161
  - sewage pumps, 2.144
- oil well pumps
  - artificial lift, 9.377
  - counterbalance, 9.386
  - electric submersible centrifugal, 9.393
  - hydraulic submersible centrifugal, 9.395–9.396
  - impulse load, 9.383
  - installation calculations, 9.382
  - minimum polished rod load, 9.384
  - net plunger stroke, 9.385
  - peak polished rod load, 9.384
  - peak torque, 9.384
  - plungers
    - fluid weight, 9.382
    - overtravel, 9.384
  - polished rod power, 9.384
  - rod weights, 9.383
  - subsurface hydraulic, 9.386–9.387
  - subsurface progressing cavity, 9.392
  - subsurface reciprocating hydraulic, 9.390–9.391
  - sucker rod, 9.378
    - stretch, 9.385
  - torque ratings, 9.382
  - tubing shrink, 9.385
- oil-ring lubrication system, single-stage steam turbines, 6.41
- on-off control systems, 7.2–7.3, 7.9
- once through intakes, ocean inlets, 10.5
- one-dimensional model, magnetic bearing design, 2.285
- open channels, frictional head losses/hydraulic gradients, 8.41
- open cycles, steam power plants, 9.75
- open drip-proof enclosures, electric motors, 6.15
- open enclosures, electric motors, 6.15
- open ended branch-line pumping systems, 8.84–8.86
- open externally vented enclosures, electric motors, 6.15
- open impeller pumps, casings, 2.104
- open impellers, 2.115
- open pipe vented enclosures, electric motors, 6.16
- open-cycle gas turbines, 6.90
- open-loop controls, 7.3

- operating
    - centrifugal pumps, 12.13–12.14
    - costs
      - displacement pump flow control, 3.78
      - steam turbines, 6.52
    - jet pumps, 4.20
    - magnetic bearing pumps, 2.292
    - requirements
      - fluid types, 11.2
      - system head curves, 11.2–11.3
    - scale models, 10.49
    - speeds
      - rotary pumps, 3.150–3.151
      - sewage systems, 9.38
    - temperatures
      - chemical pump seals, 9.122
      - composite pumps, 5.50
      - testing pumps, 13.8–13.9
  - operating basis earthquakes, seismic
    - nuclear pumps, 9.304
  - operating envelope
    - non-contacting gas lubricated seals, 2.222
    - seals, 2.207
  - operating flow ratio, L/JL
    - pumps, 4.11
  - operating frequency, sewage systems, 9.38
  - operating pressures, hydraulic presses, 9.466
  - opposed impellers, 2.128
  - optimum geometry, pumps, 1.4
  - organic acid chemical pumps, 9.117
  - organic compound chemical pumps, 9.118
  - orifice issues, bypass systems, 2.448
  - orifice meters, 2.449, 13.17
  - origins of pumps, 1.2
  - OTI volume (open-to-inlet), rotary pumps, 3.123
  - OTO volume (open-to-outlet), rotary pumps, 3.123
  - outboard bearings, 2.149
  - outboard-end pumps, 2.107
  - outer impeller hubs, 2.118
  - outer magnet encapsulation, sealless magnetic drive pumps, 2.305
  - outlet blades, centrifugal pumps, 2.34–2.35
  - outlet discharge pressure, rotary pumps, 3.144
  - outlet pipes, suction tanks, submergence, 10.25
  - outlet velocity diagrams, centrifugal pumps, 2.64
  - output torque, adjustable-speed belt drives, 6.172
  - outside-mounted seals, 2.208
  - overall efficiency, 2.329, 3.146
  - overfilling vanes, centrifugal pumps, 2.343
  - overhauling pumps, 12.17
  - overhung impellers, 2.113, 2.118
    - axial thrust, 2.126
    - sleeves, 2.138
  - overpressure fire pumps, 9.58
  - oversizing shaft at impeller, 2.135
  - overspeed trip system
    - single-stage steam turbines, 6.41
    - steam turbines, 6.46
  - OWS (oily-water separator), 9.234
  - oxygen pumps, liquid rocket propellant pumps, 9.432
- ## P
- packaged gas turbine drivers, 6.95
  - packaged gear drives, 6.152
  - packed plunger metering pumps, 9.313
  - packing glands, 2.147
  - packing rings, 2.184
  - packing seals, 2.183
  - packings
    - abrasives, 2.192
    - air leakage, 2.192
    - chemical pumps, 9.122
    - coefficients of friction, 2.187

- compression, 2.184
- continuous coil, 2.193
- lantern rings, 2.141
- materials used, 2.187–2.188
- power pumps, 3.26
- pressure issues, 2.190–2.191
- rotary pumps, 3.124
- sleeves, 2.138
- slurry pumps, 9.357
- temperature issues, 2.192
- packless stuffing boxes, 2.239
- Pamgren-Miner cumulative damage
  - law, 5.26
- paper mill pumps, 9.159, 9.182
  - black liquor, 9.163–9.164
  - bleach liquors, 9.164
  - blow tank discharge, 9.163
  - capacities, 9.175
  - chlorine dioxide, 9.165
  - digester circulating, 9.181
  - efficiencies, 9.180–9.181
  - foul condensate, 9.166
  - green liquor, 9.164
  - lime slurries, 9.164
  - liquors, 9.162
  - pipng, 9.167
    - friction losses, 9.170–9.173, 9.177–9.179
  - slurries, 9.162
  - steaming out process, 9.181
  - stock, 9.166
  - stock pumps, 9.167
  - wash liquors, 9.165
  - water pumping, 9.161
  - white liquor, 9.162
- parallel misalignment, 2.228
- parallel operations, centrifugal pumps, 2.367–2.368
- parallel pump bypass systems, 2.450
- parallel water supply systems, 9.13–9.14
- parallel-shaft gears, 6.144
- parshall flumes, 13.23–13.24
- partially stratified slurries, 9.322
  - deposition, 9.332
  - pressure gradients, 9.335–9.337
- particle impact wear, slurry pumps, 9.364
- particulates, 5.19–5.20
- peak polished rod load, oil well pumps, 9.384
- peak torque, oil well pumps, 9.384
- pedestal bearings, 2.149
- Pelton wheel turbines, 6.79
- perforated plates, head losses, 8.73
- performance
  - aircraft boost pumps, 9.414
  - centrifugal pumps, 2.24
  - condenser circulating pumps, 9.105
  - direct acting steam pumps, 3.53
  - eductors, 4.30
  - electric motors, 6.21
  - LJL pumps, 4.15
  - pipeline pumps, 9.147
  - pumps, 5.3
  - refinery pumps, 9.141
  - rotary pumps, 3.147–3.149
  - screw pumps, 3.109
  - seals, 2.198
- performance characteristic curves
  - centrifugal pumps, 2.18, 2.46, 2.334
    - axial thrust, 2.53–2.54
    - backward curved blades, 2.331
    - CFD, 2.51–2.52
    - forward curved blades, 2.332
    - mechanical efficiency, 2.50
    - non-recirculating flows, 2.46
    - non-viscous flow, 2.329–2.330
    - radial curved blades, 2.332
    - viscous flow, 2.331
    - volumetric efficiency, 2.50
  - hydraulic water pumps, 6.197
  - journal bearings, 2.259–2.260
- performance troubleshooting, 2.397
- peristaltic food/beverage pumps, 9.193
- pest control systems, 9.444
- pesticide transfer systems, 9.442
- petroleum pumps, 9.134
  - liquid viscosity, 9.150–9.154
  - transfer systems, 9.443
- See also* oil well pumps.



- pharmaceutical pumps, 9.187–9.188
- phosphoric acid chemical pumps, 9.117
- piezoelectric accelerometers, 2.422
- pigment chemical pumps, 9.116
- pilot-operated ARC valves, 2.444
- pilotless trim design ARC valves, 2.444
- pipeline pumps, 9.142–9.143
  - materials of construction, 9.145–9.147
  - performance, 9.147
- piping
  - bends, resistance coefficients, 8.65
  - discharge end, 12.9
  - displacement pumps
    - acoustic velocities, 3.64–3.65
    - pulsation responses, 3.64
  - expansion joints, 12.10
  - fitting losses, 8.53
  - friction, 8.33–8.34
  - gas turbines, 6.95
  - manifold pumps, 10.29
  - multipump systems, 10.30
  - NPSH losses, 10.30
  - paper mill pumps, 9.167
    - friction losses, 9.170–9.173, 9.177–9.179
  - screens, 10.32
  - screw pumps, 3.119
  - sewage systems, 9.41
  - strainers, 10.32
  - strains, 12.9
  - suction end, 12.8
  - suction pits, 10.28–10.29
  - surge protection, 10.31
  - vents, 12.11
  - vibration problems, 10.31
    - displacement pumps, 3.70
    - warm-up flow, 12.11
- piston food/beverage pumps, 9.193
- piston type liquid ends, steam pumps, 3.47–3.48, 3.51
- pistons
  - engines, velocities, 6.59
  - hydroviscous drives, 6.134
  - power pumps, 3.24
  - reciprocating pumps, 3.37
  - steam pumps, speeds, 3.55
- pitot static tubes, 13.18
- pitot tubes, 13.18
- pitting
  - centrifugal pumps, 2.347
  - chemical pumps, 9.118
- plain gland plates, 2.220
- plant water pumps, water treatment plants, 9.18
- plunger type liquid ends, steam pumps, 3.53
- plungers
  - oil well pumps
    - fluid weight, 9.382
    - overtravel, 9.384
  - power pumps, 3.24
  - reciprocating pumps, 3.37
- PM brushless DC motors (permanent magnet), 6.10–6.12
- pneumatic ejectors, raw sewage pumps, 9.29
- poises, 8.33
- polished rod power, oil well pumps, 9.384
- pollutants, engines, 6.60
- polymer chemical pumps, 9.115–9.116
- pony rods, power pumps, 3.32
- pool-to-pool head, drainage/irrigation pumps, 9.48
- portable drainage pumps, 9.47
- positioners, control valve actuators, 7.26
- positive displacement pumps
  - acoustic filters, 3.68
  - bypass control, 3.78
  - diagnostics, 3.70–3.71
  - flow control, 3.75
    - operating costs, 3.78
    - pumps in series, 3.83
  - food/beverage, 9.190
  - gas-charged dampeners, 3.69
  - in-line gas dampeners, 3.69
  - inadequate NPSH, 3.63

- isentropic bulk moduli, 3.66–3.67
- isothermal bulk moduli, 3.67
- paper mill pumps, 9.181
- pipng system
  - acoustic velocities, 3.64–3.65
  - pulsation responses, 3.64
  - vibration, 3.70
- positive pulsations, 3.64
- power pumps, 3.3
- pulsation control, 3.67
- shaft failures, 3.73
- side branch accumulators, 3.69
- solids pumps, 9.369
- speed changer controls, 3.76
- starting/stopping, 12.15
- suction valve unloading, 3.76–3.77
- thermal problems, 3.72
- troubleshooting, 3.63
- potable water marine pumps, 9.235
- power end
  - chemical pumps, 9.122
  - power pumps, 3.16, 3.28
- power factors, electric motors, 6.26
- power failures, 12.16, 2.376
- power measurements, 13.35
- power output, centrifugal pumps, 2.329
- power pumps, 3.3
  - antifriction pin bearings, 3.34
  - applications, 3.35
  - bhp, 3.4
  - break-away torque, 3.8
  - capacitance, 3.4
  - connecting rods, 3.31
  - crank pin bearings, 3.33
  - crankshafts, 3.28–3.29
  - crossheads, 3.32
  - crossways, 3.32
  - cylinder, 3.22
  - cylinder liners, 3.26
  - derating, 3.9
  - designing, 3.21–3.22
  - displacement, 3.4
  - eccentric straps, 3.31
  - frames, 3.28
  - liquid end, 3.22
  - liquid-plunger separation, 3.18
  - lubrication, 3.34
  - main bearings, 3.33
  - manifolds, 3.27
  - mechanical efficiency, 3.6, 3.19
  - packing, 3.26
  - pistons, 3.24
  - plungers, 3.24
  - pony rod, 3.32
  - power end, 3.16, 3.28
  - pressure, 3.4
  - pull rod, 3.33
  - pulsation, 3.10
  - pumping cycles, 3.10
  - relief valves, 3.35
  - rod load, 3.17
  - sleeve bearings, 3.33
  - slip, 3.5
  - stress limits, 3.23
  - stroke rate, 3.6
  - stuffing boxes, 3.25
  - torque, 3.8
  - unbalanced reciprocating parts
    - force, 3.18
  - unbalanced rotating parts
    - force, 3.19
  - valve covers, 3.28
  - valve dynamics, 3.14
  - valve spring rates, 3.16
  - valve springs, 3.16
  - valve stiction, 3.14
  - valves, 3.12–3.13, 3.15, 3.27
  - volumetric efficiency, 3.6–3.7
  - wrist pin bearings, 3.33
  - wrist pins, 3.31
- power ranges, gear reducers, 6.153
- power ratings
  - engines, 6.57–6.58
  - screw pumps, 3.116
- power shafts
  - Francis turbines, 6.80
  - hydraulic turbines, 6.80
- power transmission systems,
  - 6.175–6.176,
  - 6.191–6.192, 6.197
- power-recovery turbines, 6.83
- pre-bid meetings, 11.24
- pre-rotation, 2.105–2.106

- predetermined thrust direction,
  - hydraulic balancing devices, 2.130
- preoperation checks, centrifugal pumps, 12.14
- prerotation, 10.42, 10.50
- pressure
  - chemical pump seals, 9.123
  - fully stratified slurry gradients, 9.335, 9.337
  - power pumps, 3.4
  - rotary pumps, 3.145
  - seal calculations, 2.200–2.201
  - screw pump capabilities, 3.103
  - water supply system
    - differential, 9.12
- pressure head, pumping systems, 8.5, 8.10
- pressure losses, equivalent fluid slurries, 9.323
- pressure lubrication system, single-stage steam turbines, 6.41
- pressure pulsations, 2.403
  - fundamental shaft frequency, 8.105
  - high-energy pumps, 2.71
    - cavitation, 2.87
  - impeller vane frequency, 8.106
  - mining pumps, 9.209
  - scroll case frequency, 8.107
- pressure recovery, control valves, 7.23
- pressure rise, aircraft fuel pumps, 9.414–9.415
- pressure sensors, 7.7
- pressure temperature profiles,
  - canned motor pumps, 2.321
- pressure transducers, 13.18
- pressure velocity, seals, 2.202
- pressure-reducing devices, 2.145
- preventing unprimed pump operation, 2.466
- primary flow nozzles, LJJ pumps, 4.14
- primary rings, contacting liquid lubricating seals, 2.199
- prime movers, drainage/irrigation, 9.53
- primers
  - centrifugal pumps, 2.359
  - sewage pumps, 2.464
- priming
  - centrifugal pumps, 12.13
  - screw pumps, 3.120
- priming chambers, 2.456
- priming eductors, 4.41
- priming ejectors, 2.458
- priming inductors, 2.457
- priming tanks, 2.465
- profiles, discharge lines,
  - waterhammer, 8.93
- progressing tooth gear pumps, 3.129
- progressive cavity food/beverage pumps, 9.190
- progressive cavity pumps, 3.99
- propeller drainage pumps, 9.46, 9.53
- propeller irrigation pumps, 9.46, 9.53
- propeller turbines, 6.79, 6.83
- propellers, 2.113
- proportional control systems, 7.3
- proportioning pumps, 9.313
- propulsion marine pumps, 9.216
  - bearings, 9.219
  - constant differential pressure governors, 9.220
  - constant pressure governors, 9.219
  - relief valves, 9.220
  - seals, 9.219
- propylene uses, composite pumps, 5.57
- PRVs (Pressure Reducing Valves), 2.448
- public water usage, 9.5
- pull rods, power pumps, 3.33
- pull-in torque, electric motors, 6.25
- pulleys, 6.171
- pullout pumps, 2.167
- pulp mill pumps, 9.159
- pulping process, 9.159–9.160
- pulsation
  - displacement pumps, 3.67
  - power pumps, 3.10
  - responses, 3.64

- pump covers, rotary pumps, 3.124
- pump data sheets, RFQs, 11.11
- pump drives
  - adjustable-speed belt drives, 6.167
    - gear reduction, 6.169
    - input speed, 6.168
    - operations, 6.170
    - speed control, 6.169
    - V belts, 6.170
  - continuous-tooth herringbone
    - gears, 6.146
  - double helical gears, 6.146
  - gears, 6.143
  - helical gears, 6.144–6.146
  - hypoid-bevel gears, 6.148
  - parallel-shaft gears, 6.144
  - spiral-bevel gears, 6.147
  - spur gears, 6.144
  - straight-bevelgears, 6.147
  - worm gears, 6.148
  - zero-bevelgears, 6.147
- pump efficiencies, jet pumps, 4.8
- pump efficiency formula, 13.37
- pump noise, 8.109
  - cavitation, 8.111–8.113
  - control techniques, 8.113
    - airborne noise, 8.117–8.122
    - controlling noise paths, 8.115–8.116
    - source modification, 8.113–8.114
  - exposure limits, 8.124
  - flashing, 8.113
  - liquid sources, 8.111
  - measuring, 8.122, 8.124
  - mechanical sources, 8.110
- pump pits, cooling tower
  - systems, 10.6
- pump power formula, 13.36
- pump turbines, pumped
  - storage, 9.262
- pump-out vanes, 2.115, 2.126
- pumped storage systems, 9.261
  - conventional generation, 9.268
  - economic evaluation, 9.272, 9.275
  - generator motors, 9.262
  - governor times, 9.270
  - pump turbines, 9.262
  - pumping mode, 9.266
  - rotating spinning reserve, 9.269
  - surge tanks, 9.271
  - transient speeds, 9.263–9.264
- pumping chamber, rotary
  - pumps, 3.124
- pumping conditions, mining pumps, 9.197–9.198
- pumping cycles, power pumps, 3.10
- pumping mode, pumped
  - storage, 9.266
- pumping stations, 9.148
  - sump, 9.54
  - superstructure, 9.54
  - water. *See* water supply systems.
- pumping systems, 8.3–8.4
  - bar racks, head losses, 8.73
  - defining operation requirements
    - control systems, 11.4
    - fluid types, 11.2
    - operating modes, 11.3
    - pump type selection, 11.4, 11.7
    - system head curves, 11.2–11.3
  - deformation rates, 8.32
  - elevation head, 8.6
  - energy gradients, 8.12
  - equivalent head, 8.5
  - fluid characteristics, 11.7
  - friction, 8.32
  - frictional head losses, 8.41
  - head, 8.5
  - head losses, 8.32, 8.64
    - metering systems, 8.66
    - pipe frictional losses, 8.34, 8.39, 8.42–8.48
    - screens, 8.70
    - wire mesh screening, 8.71
  - hydraulic gradients, 8.12
  - incompressible liquids, 8.5
  - inertial head, 8.22–8.24
  - kinematic viscosities, 8.33
  - laminar flow, 8.32
  - meter differential pressure, 8.77
  - meter loss of head, 8.77
  - minor losses, 8.53

- multiple pump systems, total head, 8.16
- perforated plates, head losses, 8.73
- pipe bends, resistance coefficients, 8.65
- pipe friction, 8.33–8.34
- pressure head, 8.5, 8.10
- reverse-speed-torque, 8.20
- shear stress, 8.32
- siphon head, 8.25–8.31
- starting against check valves, 8.20
- starting against closed valves, 8.17
- starting against open valves, 8.20
- suction elbows, 8.66
- system-head curves, 8.13
- temperature variations, flow rates, 8.77
- throttling orifices, head losses, 8.77
- total head, 8.6–8.9
- turbulent flow, 8.32
- valves, flow coefficients, 8.56–8.58, 8.62–8.63
- variable static head, 8.15
- variable system resistance, 8.16
- velocity head, 8.5
- pumping time variations, water supply systems, 9.6
- pumps
  - air conditioning. *See* air conditioning pumps.
  - alignment, 12.3–12.4, 12.7
  - aircraft fuel, 9.409
  - ash handling, 9.111
  - axial thrust, 2.401
  - axially split, 2.99
  - backflow preventers, 2.143
  - bearings, 2.149
  - bedplates, 2.155
  - beverage. *See* beverage pumps.
  - boiler circulating, 9.108–9.109
  - bottom-suction, 2.106
  - brine, 9.259
  - canned motor pumps, 2.315
  - cantilever shaft, 2.168
  - casings, 2.102
    - feet locations, 2.110
    - handholes, 2.107
    - hydrostatic tests, 2.111
    - mechanical features, 2.107
  - cast-iron flanges, 2.110
  - cavitation, 2.398
  - centerline support, 2.157
  - centrifugal. *See* centrifugal pumps.
  - classification, 1.2–1.3
  - condenser circulating. *See* condenser circulating pumps.
  - control systems, 7.2
  - cyclone separators, 2.142
  - diaphragms, 3.85–3.87
  - diffusers, 2.97, 2.100, 2.163
  - direct acting throttle control, 3.75
  - disc diaphragm, 3.89
  - discharges
    - nozzles, 2.106
    - pipng, 12.9
    - recirculation, 2.398
  - displacement
    - flow control, 3.75
    - in series flow control, 3.83
  - double volute, 2.101
  - double-ring, 2.119
  - doweling, 12.8
  - drainage. *See* drainage pumps.
  - drive shaft systems, 6.182–6.183
  - drive-end, 2.107
  - dry vacuum, 2.458
  - eddy current couplings, 6.99
  - electric motors. *See* electric motors.
  - electronic, 3.87–3.88
  - end suction, casings, 2.102
  - erosion, 5.19
  - field locations, 12.3
  - fire protection. *See* fire protection systems.
  - flexible liners, 3.126
  - flexible pipe, bedplate issues, 2.157
  - flow control, 2.437, 2.441–2.443
  - design factors, 2.439
  - flow requirements, 2.438
  - food. *See* food pumps.
  - foot valves, 2.456
  - foundations, 12.3, 12.8

- fretting, 5.15
- fuel oil. *See* fuel oil pumps.
- gear, 3.123, 3.127
- gerotor, 3.129
- groundwater, 9.3–9.4
- grouting, 12.8
- heater drain. *See* heater drain pumps.
- high purity water and erosion, 5.35
- horizontal-shaft, 2.99
- hot water. *See* hot water pumps.
- impellers, 2.97, 2.113–2.115
- inboard-end, 2.107
- inducers, 2.114
- intakes, 10.3
- internal vane, 3.126
- irrigation. *See* irrigation pumps.
- jet
  - compressible flow case solutions, 4.8
  - equations, 4.7
  - flow regimes, 4.5–4.6
  - jet losses, 4.8
  - pump efficiencies, 4.8
- jet. *See* jet pumps.
- lake water. *See* lake water pumps.
- leveling, 12.4, 12.7
- lifetimes, 5.3
- liquid jet
  - compressible flow case solutions, 4.8
  - equations, 4.7
  - flow regimes, 4.5–4.6
  - jet losses, 4.8
  - pump efficiencies, 4.8
- liquid rocket propellant, 9.432
- LJL, equations, 4.9–4.10
- lobe, 3.123, 3.128–3.129
- low flow rates, 2.438
- magnetic bearings, 2.277–2.278
- magnetic drives, 2.178
- maintenance. *See* maintenance.
- marine. *See* marine pumps.
- materials of construction, 5.3–5.4, 5.32, 5.35
- metering, 9.313
- motor failure, waterhammer, 8.95–8.96
- motor-driven, 3.87
- multiple screw, 3.99
- multistage, 2.99
  - casings, 2.107, 2.110
  - interstage passages, 2.108
- non-drive-end, 2.107
- nuclear, 9.279
- oil well, 9.377
- open impeller casings, 2.104
- optimum geometry, 1.4
- outboard-end, 2.107
- overhauling, 12.17
- paper/pulp. *See* paper mill pumps.
- performance troubleshooting, 2.397
- pharmaceutical. *See* pharmaceutical pumps.
- pipeline. *See* pipeline pumps.
- power-driven, speed control, 3.75
- pre-rotation, 2.105–2.106
- pressure pulsations, 2.403
- preventing unprimed operation, 2.466
- priming, 2.455–2.458
- progressing tooth gear, 3.129
- progressive cavity, 3.99
- radial thrust, 2.100–2.101, 2.402
- radially split, 2.99
- radially split double casing, 2.110
- raw sewage, 9.29
- refinery. *See* refinery pumps.
- refrigeration, 9.259
- rigid vane, 3.126
- ring casing, 2.110
- rotary, 3.123
- rotation, 2.107
- safety shutdown systems, 2.445
- saline water and erosion, 5.36
- screw, 3.99
- screw-and-wheel, 3.128
- seal chambers, 2.139, 2.141
- sealing liquids, 2.141–2.143
- sealless. *See* sealless pumps.
- seawater. *See* seawater pumps.

- selecting, 1.5
  - self-priming, 2.461–2.462
  - semi-open impeller casings, 2.105
  - series unit, 2.107
  - sewage. *See* sewage systems.
  - shafts, 2.132
    - failures, 2.401–2.403
  - shutdown, waterhammer
    - prevention, 8.103
  - side-suction, 2.106
  - single-chamber primers, 2.456
  - single-stage, 2.99
  - single-volute, 2.168
  - single-volute casing, 2.100
  - solenoid, 3.87
  - solid casings, 2.102
  - specific speed, 1.4
  - split casings, 2.102
  - stage pieces, 2.108
  - starting, waterhammer
    - prevention, 8.102
  - steam heat. *See* steam heat pumps.
  - stop pieces, 2.106
  - straight-radial-vane
    - high-speed, 2.179
  - stuffing boxes, 2.139–2.141
  - submersible motor-driven
    - wet-pit, 2.177
  - suction piping, 12.8
  - suction recirculation, 2.398–2.400
  - surface water, 9.3
  - testing. *See* testing pumps.
  - thrust bearings, 2.149
  - tubular diaphragm, 3.91
  - two-chamber primers, 2.457
  - vacuum primers, 2.458
  - vane, 3.123
  - vertical dry-pit, 2.158–2.160
  - vertical propeller, 2.166–2.167
  - vertical sewage, 2.158
  - vertical shaft, 2.99
  - vertical single-suction, 2.160–2.162
  - vertical turbine, 2.163–2.165
  - vertical wet-pit, 2.163
  - volute, 2.97, 2.168
  - volute-casing, 2.99
  - vortex pumps, 2.389
  - wear, 5.13
  - well. *See* well pumps.
  - wet vacuum, 2.458
  - purchase orders, 11.30
  - purchase recommendations, 11.29
  - purity of solutions, 9.115
  - pusher-type seals, 2.211
  - PV, pressure times velocity, 2.202
  - PWM (pulse width modulation)
    - electric drives, 6.109
    - frequency inverters, 6.118
  - PWR plants (pressurized water reactor), 9.279
    - boron injection recirculation pumps, 9.280
    - charging pumps, 9.280
    - chilled water pumps, 9.283
    - component cooling water pumps, 9.280
    - containment spray pumps, 9.280
  - ECCS (emergency core cooling system), 9.280
  - reactor coolant pumps, 9.280
  - recycle evaporator feed pumps, 9.283
  - residual heat removal pumps, 9.280
  - RHR pumps (residual heat removal), 9.280
  - safety injection pumps, 9.280
  - spent fuel pit pumps, 9.283
  - spent resin sluicing pumps, 9.283
- ## Q
- Q, rotary pumps, 3.138–3.139
  - Q3D (quasi three-dimensional analysis), 2.48
  - qualification analysis, seismic nuclear pumps, 9.308
  - qualification testing, seismic nuclear pumps, 9.309

quantity meters, 13.14  
 quick opening slow closing  
 valves, waterhammer  
 prevention, 8.101

## R

Rabinowitsch-Mooney technique,  
 scaling laminar flow, 9.329  
 radial blades, centrifugal  
 pumps, 2.332  
 radial clearances, leakage  
 joints, 2.122  
 radial impellers, axial thrust, 2.127  
 radial magnet forces, sealless  
 magnetic drive pumps, 2.304  
 radial pins, impeller rings, 2.123  
 radial thrust, 2.101, 2.402  
 centrifugal pumps, 2.372  
 pumps, 2.100  
 radial vane impellers, 2.113  
 radially split casings, 2.102  
 radially split double casing  
 pumps, 2.110  
 radially split pumps, 2.99  
 radiators, engines, 6.64–6.65  
 raised-face flanges, 2.110  
 rangeability, control valves, 7.21  
 Ranney wells, 10.10  
 ratchets, electric motors, 6.20  
 rate of flow meters, 13.15  
 ratings  
 adjustable-speed belt drives, 6.172  
 eddy current couplings, 6.106  
 gas turbines, 6.91  
 ratios, gear reducers, 6.153  
 raw sewage pumps, 9.29  
 firm capacity, 9.29  
 pneumatic ejectors, 9.29  
 RD-170 rocket engine, 9.439  
 reaction stage, steam turbines, 6.40  
 reactor coolant pumps, 9.280  
 reactor core isolation cooling pumps,  
 BWR plants, 9.285  
 reactor feed pumps, 9.150  
 reactor water cleanup pumps, BWR  
 plants, 9.284  
 recessed impellers, 2.168  
 reciprocating cargo pumps, 9.248  
 reciprocating hydraulic presses,  
 9.464–9.465  
 reciprocating pumps  
 discharge stroke, 3.38  
 double acting, 3.38  
 liquid cylinders, 3.37  
 liquid end, 3.37  
 pistons, 3.37  
 plungers, 3.37  
 single-acting, 3.38  
 suction stroke, 3.38  
 troubleshooting, 12.24  
 recirculating flow, centrifugal  
 pumps, 2.19  
 recirculation, 2.398, 2.400  
 canned motor pumps, 2.321  
 centrifugal pumps, 2.369–2.370  
 discharge pumps, 2.463  
 high-energy pumps, 2.78–2.79  
 recirculation pumps, BWR  
 plants, 9.283  
 recirculation to suction pumps, 2.462  
 recommended test procedures,  
 13.12–13.13  
 records of pump test data, 13.38  
 recycle evaporator feed pumps, 9.283  
 reduced flow  
 bolier feed pumps, 9.90  
 centrifugal pumps, 12.13  
 reduced power consumption,  
 magnetic bearings, 2.281  
 reducing waterhammer, 8.93, 8.95  
 refiner mechanical pulp, 9.159  
 refinery pumps, 9.133–9.134  
 construction, 9.134, 9.137  
 drivers, 9.142  
 materials of construction, 9.142  
 performance, 9.141  
*See also* oil well pumps.  
 refining industry, seal  
 standards, 2.215  
 refrigeration pumps, 9.259



- lubricating oil transfer, 9.260
- refrigerant circulation, 9.260
- refueling cryogenic pumps, 9.401
- regulation of flow, condensate pumps, 9.100
- regulation of flow rate, centrifugal pumps, 2.365
- regulations, fire protection systems, 9.60
- reliability
  - magnetic bearings, 2.281
  - sewage systems, 9.38
- relief chambers, 2.119
  - leakage joints, 2.119
  - pressure-reducing devices, 2.145
- relief valves, 12.11
  - power pumps, 3.35
  - propulsion marine pumps, 9.220
- remote monitoring, mining pumps, 9.211
- renewable shaft sleeves, 2.136
- repairing equipment, 12.17
- requisitions, see RFQs, 11.9
- residual heat removal pumps, PWR plants, 9.280
- resistance coefficients, pipe bends, 8.65
- resistance to cavitation, 5.13
- resistance to wear, slurry pumps, 9.364
- response spectra, seismic nuclear pumps, 9.304
- response speeds
  - hydrodynamic drives, 6.138
  - hydrokinetic drives, 6.136
  - hydroviscous drives, 6.138
- return passages, centrifugal pumps, 2.45
- reverse-speed-torque, pumping systems, 8.20
- reversed impellers, centrifugal pumps, 2.382
- Reynolds equation, 2.249, 2.251
- RFQs (requests for quotation), 11.9
  - bidders lists, 11.20–11.22
  - commercial terms and conditions, 11.9
  - energy evaluations, 11.11
  - inspection checklists, 11.17
  - life cycle cost evaluations, 11.13–11.15
  - noise data sheets, 11.19–11.20
  - pump data sheets, 11.11
  - technical specifications, 11.9
  - technical specs, 11.10
  - testing checklists, 11.17
  - vendor data requirement forms, 11.17
- rheograms, non-Newtonian flows, 9.325–9.326
- RHR pumps (residual heat removal), 9.280, 9.285
- rigid couplings, 6.175–6.176
- rigid shafts, 2.133, 6.185–6.186
- rigid vane pumps, 3.126
- rigid water column theory, waterhammer, 8.93
- rigidity of seismic nuclear pumps, 9.308
- ring-casing pumps, 2.110
- ring-section pumps, 2.110
- rings, intermeshing, 2.119
- rising head characteristic, 2.334
- rod load, power pumps, 3.17
- rod weights, oil well pumps, 9.383
- roller bearings, slurry pumps, 9.357
- rolling element bearings, 2.149, 6.18
- rolling-media filters, gas turbines, 6.94
- rotary cargo pumps, 9.248
- rotary chemical pumps, 9.120
- rotary pumps, 3.123
  - abrasives, 3.137
  - affinity laws, 3.132
  - capacity, 3.139–3.140
  - casing housing, 3.124
  - cavitation, 3.135
  - centrifugal pump
    - comparisons, 3.130
  - corrosiveness of fluids, 3.136
  - CTIO volume (closed-to-inlet-and-outlet), 3.123
  - displacement, 3.138, 3.141–3.143
  - dissolved gases, 3.134

- dry running, 3.133
- end plates, 3.124
- entrained air, 3.134
- flow curves, 3.131
- fluid lubricity, 3.135
- heating jackets, 3.125
- high viscosity uses, 3.132
- inlet pressure, 3.134
- input power, 3.145
- installing, 3.133
- integral relief valves, 3.125
- lantern rings, 3.124
- materials of construction, 3.125
- mechanical efficiency, 3.146
- mechanical friction power, 3.145
- mechanical seals, 3.124
- noise, 3.134
- non-Newtonian fluids, 3.136
- operating speeds, 3.150–3.151
- OTI volume (open-to-inlet), 3.123
- OTO volume (open-to-outlet), 3.123
- overall efficiency, 3.146
- packings, 3.124
- performance, 3.147–3.149
- pressure issues, 3.144–3.145
- pumping chamber, 3.124
- rotating assembly, 3.124
- safety relief valves, 3.125
- seal cages, 3.124
- seal chambers, 3.124
- slip, 3.138–3.139
- speed issues, 3.143
- stators, 3.124
- suction strainers, 3.134
- temperature of fluids, 3.135
- timed, 3.124
- troubleshooting, 12.23
- untimed arrangement, 3.124
- vapor pressure, 3.138
- viscosity if fluids, 3.135
- viscous power losses, 3.145
- Volumetric efficiency, 3.146, 3.149
- rotating assembly, rotary pumps, 3.124
- rotating seals, 2.211
- rotating spinning reserve, pumped storage, 9.269
- rotating trash screens, 10.15
- rotation, 2.107
- rotative speed
  - centrifugal pumps, 2.27
  - screw pumps, 3.114
- rotodynamic beverage pumps, 9.189
- rotodynamic food pumps, 9.189
- rotor armature, canned motor pumps, 2.318
- rotor dynamics, magnetic bearings, 2.281
- rotor sleeves, canned motor pumps, 2.318
- rotor whirl, bearings, 2.266
- rotors
  - canned motor pumps, 2.316
  - centrifugal pumps, shape and speed, 2.23
  - hydrodynamic bearing effect, 2.135
  - hydrokinetic drives, 6.129
  - hydroviscous drives, 6.134
  - magnetic bearings
    - clearances, 2.282
    - dynamics, 2.283
  - single-stage steam turbines, 6.41
  - RP1 pumps
    - liquid rocket propellant pumps, 9.433
- RRS (required response spectrum), seismic nuclear pumps, 9.304
- rubber jaw couplings, 6.179
- rules, fire protection systems, 9.60
- runners
  - Francis turbines, 6.79
  - hydraulic turbines
    - running speed, 6.82
  - impulse turbines, 6.79
  - turbines, 6.79
- Rütschi formula, centrifugal pumps, 2.384

**S**

- safe temperatures, electric
  - motors, 6.25
- safety injection pumps, PWR
  - plants, 9.280
- safety relief valves, rotary
  - pumps, 3.125
- safety shutdown systems, 2.445
- saline water, erosion corrosion, 5.36
- salt solution chemical pumps, 9.118
- sampling pumps, water treatment
  - plants, 9.18
- sand/mud eductors, 4.36
- sanitary marine pumps, 9.236
- Saturn V booster rockets, 9.432
- scale models, 13.39–13.40
  - flow distribution, 10.51
  - free surface vortices, 10.49
  - intake loss coefficient, 10.50
  - operating, 10.49
  - prerotation, 10.50
  - subsurface vortices, 10.49
- scaling centrifugal pumps, 2.19
- scaling laminar flow, 9.329
- SCC (stress corrosion cracking),
  - stainless steel, 5.7
- scoop tubes, hydrokinetic
  - drives, 6.129
- scoop-trimming fluid drives,
  - 6.130–6.131
- SCR (silicon-controlled rectifier),
  - electric drive power
    - supplies, 6.110
- screens, 10.14, 10.16
  - head losses, 8.70
  - intake design, 10.47
  - pipings, 10.32
- screw pumps, 3.99
  - advantages, 3.100
  - delivered capacity, 3.115
  - delivery, 3.101
  - dissolved air issues, 3.113
  - double-end, 3.104
  - entrained air issues, 3.113
  - foundations, 3.120
  - GVF's (gas void fractions), 3.118
  - installing, 3.119
  - internal axial velocity limits, 3.109
  - leakage, 3.101
  - locks, 3.101
  - multiphase uses, 3.117
  - noise, 3.120
  - non-Newtonian liquids,
    - 3.113–3.114
  - NPSH, 3.110–3.112
  - performance, 3.109
  - pipe sizing, 3.119
  - power ratings, 3.116
  - pressure capability, 3.103
  - priming, 3.120
  - rotative speed, 3.114
  - seals, 3.109
  - single-end, 3.104
  - slip, 3.102
  - timed rotor, 3.103, 3.106–3.107
  - untimed rotor, 3.103, 3.107–3.108
  - vapor pressure issues, 3.110
  - viscosity issues, 3.113
- screw-and-wheel pumps, 3.128
- scroll case frequency pressure
  - pulsations, 8.107
- scum pumps, 9.33–9.34
- SDF's (single degree of freedom oscillators), seismic nuclear pumps, 9.306
- seal cages, 2.141, 2.186
  - condensate pumps, 9.99
  - rotary pumps, 3.124
- seal chambers, 2.139, 2.141
  - chemical pumps, 9.122
  - rotary pumps, 3.124
- sealed ball bearings, 2.150
- sealing liquids, 2.141
  - check valves, 2.143
  - lantern rings, 2.141

- sealless chemical pumps, 9.124
- sealless magnetic drive pumps, 2.297
  - axial magnet forces, 2.304
  - bearings, 2.308, 2.310
  - breakaway torque, 2.303
  - closed coupling, 2.305
  - conduction rings, 2.298
  - containment shell, 2.305
  - dry running, 2.310
  - dual containment shells, 2.308
  - eddy current losses, 2.306–2.307
  - flow paths, 2.311
  - gaps, 2.299
  - inner magnet encapsulation, 2.304
  - magnet blocks, 2.303
  - outer magnet encapsulation, 2.305
  - radial magnet forces, 2.304
  - transmittal torque, 2.303
- sealless pumps, 2.179, 2.295
- seals
  - angular misalignment, 2.228
  - balance, 2.200–2.201
  - balanced, 2.211
  - chamber design, 2.220
  - chemical pumps, 9.122
    - chamber pressures, 9.123
    - temperature issues, 9.122
  - coefficient of friction, 2.202
  - contacting liquid lubricating, 2.197
    - mating rings, 2.199
    - primary rings, 2.199
    - refining industry
      - standards, 2.215
  - coolant flow, 2.204–2.205
  - dual-pressurized gas
    - lubricated, 2.223
  - face pressure, 2.201
  - flushes, 2.204
  - food/beverage pumps, 9.193
  - full-convolution bellows, 2.214
  - gland plates, 2.220
  - half-convolution bellows, 2.214
  - heat removal, 2.203
  - inside-mounted, 2.208
  - installing, 2.228
  - leakage, 2.207
  - main coolant pumps, BWR
    - plants, 9.290
  - materials of construction, 2.227
  - multiple, 2.208
  - multiple spring, 2.211
  - multiple-convolution bellows, 2.214
  - non-contacting gas lubricated,
    - 2.221–2.222
  - non-contacting gas
    - lubricating, 2.198
  - nonpusher, 2.214
  - operating envelope, 2.207
  - outside-mounted, 2.208
  - parallel misalignment, 2.228
  - performance analysis, 2.198
  - pressure calculations, 2.200–2.201
  - pressure velocity, 2.202
  - propulsion marine pumps, 9.219
  - pusher-type, 2.211
  - refining industry standards, 2.215
  - rotating, 2.211
  - screw pumps, 3.109
  - sewage systems, 9.41–9.42
  - single, 2.208
  - single spring, 2.211
  - slurry pumps, 9.357
  - split pusher-type, 2.212
  - stationary, 2.211
  - tandem, 2.209
  - unbalanced, 2.211
- seawater and erosion corrosion, 5.37
- seawater pumps, 9.259
- seawater service marine
  - pumps, 9.230
- second law of thermodynamics, 2.10
- secondary containment, canned
  - motor pumps, 2.318
- segmented throttle bushings,
  - floating rings, 2.240–2.241
- seismic nuclear pumps
  - critical damping, 9.302
  - degrees of freedom, 9.302
  - finite element method
    - analysis, 9.303
  - floor acceleration, 9.303
  - ground acceleration, 9.303

- load stress, 9.310
- modal analysis, 9.303
- natural frequencies, 9.308
- natural frequency, 9.304
- operating basis earthquakes, 9.304
- qualification analysis, 9.308
- qualification testing, 9.309
- response spectra, 9.304–9.306
- SSEs, 9.306
- stress limits, 9.310
- time history analysis, 9.307
- time history of acceleration, 9.307
- TRS (test response spectrum), 9.307
- ZPA (zero period acceleration), 9.307
- selecting pumps, 1.5
- selective leaching corrosion,
  - chemical pumps, 9.119
- self-aligning ball bearings, 2.151
- self-aligning bearings, 2.149
- self-contained priming units, 2.461
- self-priming centrifugal pumps, 2.462
- self-releasing couplings, electric motors, 6.20
- semi-open impeller pumps,
  - casings, 2.105
- semiannual inspections, 12.16
- semiguarded enclosures, electric motors, 6.15
- semiopen impellers, 2.115–2.127
- sensitization, 5.10
- sensors, 7.4–7.7
- series operations, centrifugal pumps, 2.367–2.368
- series unit pumps, 2.107
- series water supply systems, 9.13–9.14
- serrated throttle bushings, 2.239–2.240
- service factor ratings
  - adjustable-speed belt drives, 6.172
  - electric motors, 6.25
- service water sewage pumps, 9.33
- settled sewage pumps, 9.32
- settling slurries
  - deposition, 9.332
  - transport systems, 9.345
- sewage marine pumps, 9.236
- sewage pump systems, 9.25
  - bearings, 9.42
  - capacity planning, 9.37
  - collection, 9.26
  - concentrated sludge/scum pumps, 9.34–9.35
  - control systems, 9.40
  - cycle time, 9.38
  - drivers, 9.39
  - grease/oil seals, 2.144
  - head-capacity curves, 9.39
  - operating frequency, 9.38
  - operating speeds, 9.38
  - pipng, 9.41
  - priming systems, 2.464
  - raw sewage pumps, 9.29
  - reliability, 9.38
  - scum pumps, 9.33–9.34
  - seals, 9.41–9.42
  - service water systems, 9.33
  - settled sewage pumps, 9.32
  - sludge pumps, 9.33–9.34
  - surge control, 9.41
  - treatment, 9.26–9.27
  - valves, 9.41
  - vertical, 2.158
  - water-sealing tanks, 2.144
- shafts, 2.132
  - chemical pumps, 9.123
  - critical speed, 6.187
  - critical speeds, 2.132–2.133
  - deflection, 2.134
  - distance sleeves, 2.136
  - drive systems, 6.182
    - spacers, 6.183
  - elongation, vertical pumps, 2.175
  - failures, 2.401, 3.73
  - flexible, 2.133
  - flexible drive, 6.186
  - floating, 6.184
  - hydrokinetic drives, 6.129
  - interstage sleeves, 2.136

- Lomakin effect, 2.135
- materials of construction, 5.29–5.30
- radial load failures, 2.403
- rigid, 2.133, 6.185–6.186
- sizing, 2.135
- sleeves, 2.137
  - O rings, 2.138
  - packing, 2.138
  - renewable, 2.136
- steam turbines, orientation, 6.39
- torsional stress, 6.186
- turbines, 6.80
- shear rate, 8.32
- shear stress, 8.32
- shells, slurry pumps, 9.358, 9.365
- ship service pumps, 9.229
- ship-loading cryogenic pumps, 9.405
- shipping pumps, 12.2
- shop tests, 13.2
- shrouds, centrifugal pumps, profiles, 2.31–2.33, 2.62
- shunt-wound DC motors, 6.8
- shutdown process, waterhammer prevention, 8.103
- shutdown systems, 2.445
- side branch accumulators, displacement pumps, 3.69
- side-suction pumps, 2.106
- sigma, turbines, 6.83
- similitude, 2.20
- simplex steam pumps, 3.40, 3.45
- simplified dynamic analysis, seismic nuclear pumps, 9.308
- single seals, 2.208
- single spring seals, 2.211
- single-acting reciprocating pumps, 3.38
- single-chamber primers, 2.456
- single-curvature vanes, 2.113
- single-end screw pumps, 3.104
- single-row angular contact ball bearings, 2.151
- single-row deep-groove ball bearings, 2.151
- single-shaft gas turbines, 6.90
- single-stage pumps, 2.99
  - axial lengths, 2.29
  - axial thrust, 2.124
- single-stage steam turbines, 6.39, 6.41
  - bearing cases, 6.41
  - casing sealing glands, 6.41
  - efficiencies, 6.47
  - governors, 6.41
  - rotors, 6.41
  - steam chest, 6.41
- single-steam steam turbines, overspeed trip system, 6.41
- single-suction impellers, 2.113, 2.126–2.128
- single-unit adjustable-speed electric drives. *See* electric drives.
- single-volute casing pumps, 2.100
- single-volute pumps, 2.168
- siphon head, pumping systems, 8.25–8.31
- siphons, 4.23, 4.43
  - air, 4.47
  - annular, 4.44
  - standard, 4.44
- site maintenance, 12.2
- size effect on efficiency, centrifugal pumps, 2.24
- sizing
  - centrifugal pumps, 2.28–2.29
  - eddy current couplings, 6.106
  - shafts, 2.135
- sleeve bearings, 2.149
  - electric motors, 6.18
  - power pumps, 3.33
- sleeves
  - O rings, 2.138
  - overhung impellers, 2.138
  - packing, 2.138
  - shafts, 2.136–2.137
- sliding abrasion wear, slurry pumps, 9.364
- slip
  - loss, fluid couplings, 6.139
  - power pumps, 3.5
  - rotary pumps, 3.138–3.139
  - screw pumps, 3.102

- slip eddy current couplings, 6.106
- slip speed, eddy current couplings, 6.100–6.101
- sludge pumps, 9.27, 9.33–9.34
- slurries
  - complex flows, 9.338–9.339
  - equivalent fluid
    - hydraulic gradient, 9.324
    - pressure losses, 9.323
  - flow characteristics, 9.322–9.323
  - inclined flows, 9.342
  - laminar flow, scaling, 9.329
  - particulate abrasiveness, 5.20
  - vertical flows, 9.341
- slurry paper mill pumps, 9.162
- slurry pumps, 9.321–9.322, 9.351–9.352
  - casings, 9.357
  - centrifugal pumps, 2.26
  - coatings, 5.44
  - designing, 9.343–9.345
  - efficiencies, 9.360–9.361
  - hydraulic design, 9.353
  - impellers, 9.357
  - inserts, 5.44
  - liners, 5.44, 9.365
  - materials of construction, 5.43–5.44
  - particle impact wear, 9.364
  - roller bearings, 9.357
  - seals, 9.357
  - shells, 9.358, 9.365
  - sliding abrasion wear, 9.364
  - solids effects, 9.360
  - wear, 9.353, 9.363, 9.365
- smothering glands, 2.147
- solenoid pumps, 3.87
- soleplates, 2.156–2.157, 12.3
- solid casings, 2.102
- solid state adjustable-frequency inverters, adjustable-frequency drives, 6.119–6.120
- solids effects, slurry pumps, 9.360
- solids handling eductors, 4.37
- solids in suspension, solutions, 9.114
  - solids pumps, 9.321, 9.351, 9.369
    - flushing, 9.374
    - maintenance, 9.376
    - materials of construction, 9.371
    - packing wear, 9.372
    - process stream pumping, 9.370
    - surge legs, 9.374, 9.376
    - valves, 9.371–9.372
  - solutions
    - accelerators, 9.115
    - acidic, 9.114
    - aeration, 9.114
    - alkalinity, 9.114
    - concentrations, 9.113–9.114
    - constituents, 9.113
    - inhibitors, 9.115
    - purity, 9.115
    - solides in suspension, 9.114
    - temperatures, 9.114
  - source modification, noise control, 8.113–8.114
  - sources of pump noise, 8.110
  - space shuttle booster pumps, 9.437
  - spacing of nozzle throat, L<sub>JL</sub> pumps, 4.14
  - spare parts, 12.19
  - specific pump speeds, waterhammer, 8.94
  - specific speed, pumps, 1.4
  - speed changer controls, displacement pumps, 3.76
  - speed characteristic, turbines, 6.86
  - speed control
    - adjustable-speed belt drives, 6.169
    - centrifugal pumps, 2.21–2.23
    - electric motors, 6.23
    - engines, 6.60
    - gear reducers, 6.153
    - hydraulic turbines, runners, 6.82
    - power-driven pumps, 3.75
    - regulation, fluid couplings, 6.136
    - rotary pumps, 3.143
    - steam turbines, 6.43
    - variation, 6.45
  - speed measurements, 13.36

- speed rings, vertical dry-pit pumps, 2.162
- speed-torque curves, ac adjustable-voltage drives, 6.111
- spent fuel pit pumps, PWR plants, 9.283
- spent resin sluicing pumps, PWR plants, 9.283
- spindle proportioning eductors, 4.34
- spiral-bevel gears, 6.147
- splashproof enclosures, electric motors, 6.15
- split casings, 2.102
- split glands, 2.147
- split pusher-type seals, 2.212
- split rigid couplings, 6.175
- split-case fire pumps, 9.58
- split-shaft gas turbines, 6.90
- spring-grid couplings, 6.180
- spur gears, 6.144
- squeeze film effect, 2.252
- squirrel-cage induction motors, 6.4–6.5
- SR brushless dc motors (Switched Reluctance), 6.13
- SSEs (safe shutdown earthquakes), nuclear pumps, 9.301, 9.306
- stability, journal bearings, 2.270–2.273
- stability analyses, bearings, 2.268
- stable head characteristic, 2.334
- stage pieces, 2.108
- stainless steel
  - casings, 5.29
  - shafts, 5.30
  - wear rings, 5.31
- standard datum, shaft pumps, 2.328
- standard siphons, 4.44
- standards
  - composite pumps, 5.60
  - gas turbines, 6.91
- standby liquid control system pumps, BWR plants, 9.285
- standby pumps, auxiliary services, 12.16
- standpipe cooling systems, engines, 6.66
- starters
  - electric motors, 6.27–6.28
  - engines, 6.70–6.71
  - high specific speed centrifugal pumps, 2.364
  - low specific speed centrifugal pumps, 2.361–2.362
  - medium specific speed centrifugal pumps, 2.364
- starting
  - gas turbines, 6.94
  - pumped storage systems, 9.266
  - pumps
    - centrifugal pumps, 12.14
    - positive displacement pumps, 12.15
    - standby pumps, 12.16
    - steam turbine pumps, 12.15
    - waterhammer prevention, 8.102
- static analysis, seismic nuclear pumps, 9.308
- static excitation, synchronous motors, 6.7
- static head
  - pumping systems, 8.13
  - water supply systems, 9.12
- static instability, centrifugal pumps, 2.56
- static load failure, 2.401
- static pressure head, centrifugal pumps, 2.10
- static pressure increases, centrifugal pumps, 2.16
- static pressure losses, centrifugal pumps, 2.14
- static shaft deflection, 2.134
- static stability, centrifugal pumps, 2.56
- static thrust, 2.401
- stationary seals, 2.211
- stationary wearing rings, 2.122
- stators
  - canned motor pumps, 2.315
  - liners, 2.318
  - magnetic bearings, 2.284
  - rotary pumps, 3.124
  - windings, squirrel-cage induction motors, 6.5



- steam chest, single-stage steam turbines, 6.41
- steam consumption, steam pumps, 3.58
- steam ends, steam pumps, 3.40, 3.45, 3.57
- steam heat pumps, 9.256
- steam power plants, 9.73–9.74
  - boiler feed pumps, 9.77
    - capacities, 9.78
    - NPSH, 9.78–9.79
  - booster pumps, 9.84
  - closed cycles, 9.75
  - discharge pressures, 9.85
  - drivers, 9.85–9.87
  - efficiencies, 9.94–9.95
  - head capacity curve slope, 9.85
  - load reduction, transient conditions, 9.79–9.81
  - open cycles, 9.75
- steam pumps, 3.37
  - brake horsepower, 3.58
  - direct acting, 3.40
  - displacement, 3.53
  - duplex, 3.40
  - liquid end, 3.47
    - diameter, 3.56
    - piston type, 3.47–3.48, 3.51
    - plunger type, 3.53
    - valves, 3.52
  - materials of construction, 3.45, 3.47
  - mechanical efficiencies, 3.57
  - piston speed, 3.55
  - simplex, 3.40
  - steam consumption, 3.58
  - steam ends, 3.40, 3.45
    - diameter, 3.57
  - throttle control, 3.75
  - troubleshooting, 12.25
  - water horsepower, 3.59
- steam rates, steam turbines, 6.47
- steam turbine marine pumps, 9.216
- steam turbine pumps, 12.15
- steam turbines, 6.37–6.39
  - control systems, 6.41
  - direct connected, 6.39
  - efficiencies, 6.48
  - energy conversion, 6.46
  - geared, 6.39
  - governors, 6.41
  - impulse stage, 6.39
  - maximum speed rise, 6.45
  - multistage, 6.47
  - operating cost, 6.52
  - overspeed trip system, 6.46
  - reaction stage, 6.40
  - shaft orientation, 6.39
  - single-stage, 6.39
  - speed ranges, 6.43
  - speed variation, 6.45
  - steam rates, 6.47
  - superheat, 6.48, 6.51
- steam turbogenerators
  - auxiliary circulating pumps, 9.228
  - auxiliary condensate pumps, 9.228
  - lubricating oil pumps, 9.228
- steaming out process, paper mill pumps, 9.181
- steep characteristic, 2.334
- stellite-coated wear rings, 5.32
- step wearing rings, 2.119
- stern tube lubricating oil marine pumps, 9.231
- stock, paper mill pumps, 9.166–9.167
- stop pieces, 2.106
- stopping
  - centrifugal pumps, 12.14
  - positive displacement pumps, 12.15
    - steam turbine pumps, 12.15
    - waterhammer prevention, 8.103
- straight line approximation, L/JL pumps, 4.14
- straight-bevel gears, 6.147
- straight-radial-vane high-speed pumps, 2.178
- straight-vane radial impellers, 2.113
- strain on piping systems, 12.9
- strainers
  - piping, 10.32
  - suction end, 12.10
- stress corrosion cracking, chemical pumps, 9.119

- stress limits
  - power pumps, 3.23
  - seismic nuclear pumps, 9.310
- stroke rate, power pumps, 3.6
- structure borne noise, 8.116
- stuffing boxes, 2.139, 2.141
  - air leakage, 2.192
  - gland plates, 2.186
  - lantern rings, 2.141
  - mechanical seals, 2.148
  - packing glands, 2.147
  - packings
    - abrasives, 2.192
    - materials used, 2.187–2.188
  - power pumps, 3.25
  - pressure issues, 2.190–2.191
  - slurry pumps, 9.357
  - smothering glands, 2.147
  - temperature issues, 2.192
  - water-cooled, 2.145
- submergence, suction tank outlet pipes, 10.25
- submergence levels, intakes, 10.25
- submersible enclosures, electric motors, 6.16
- submersible motor-driven wet-pit pumps, 2.177
- submersible raw sewage pumps, 9.29
- submersible turbine irrigation pumps, 9.47
- subscript designations, centrifugal pumps, 2.8
- subsea multiphase pumps, 3.118
- subsurface hydraulic oil pumps, 9.386–9.387
- subsurface progressing cavity oil pumps, 9.392
- subsurface reciprocating hydraulic oil pumps, 9.390–9.391
- subsurface vortices, 10.40, 10.49
- sucker rod oil well pumps, 9.378
- sucker rod stretch, oil well pumps, 9.385
- suction case, vertical turbine pumps, 2.164
- suction elbows, 8.66
- suction eye, impellers, 2.118
- suction feed helicopter fuel pumps, 9.411
- suction flanges, 2.110
- suction head, units of measure, 13.3
- suction head rings, leakage joints, 2.118
- suction lift, 10.13, 13.3
- suction manifolds, power pumps, 3.27
- suction nozzles, centrifugal pumps, 2.58
- suction piping, water supply systems, 9.9, 12.8
- suction pits
  - eddies, 10.24
  - environmental issues, 10.18
  - intakes, submergence levels, 10.25
  - model tests, 10.22
  - piping, 10.28–10.29
  - vortices, 10.22–10.23
- suction recirculation, 2.370, 2.398, 2.400
- suction strainers, 3.134, 12.10
- suction stroke, reciprocating pumps, 3.38
- suction tanks, outlet pipes, submergence, 10.25
- suction throttling, centrifugal pumps, 2.366
- suction valves
  - power pumps, 3.27
  - unloading, displacement pumps, 3.76–3.77
- suction-specific speed
  - centrifugal pumps, 2.352
  - high-energy pumps, 2.84–2.85
- suggested test procedures, 13.12–13.13
- sulfide stress corrosion cracking, 5.7
- sulfuric acid applications, composite pumps, 5.57
- sulfuric acid chemical pumps, 9.116
- sump pumps, 2.163, 9.54, 9.209–9.210
- superheat, steam turbines, 6.48, 6.51
- superstructure, pumping stations, 9.54

support systems, 2.155, 2.163  
 surface treatments, fatigue  
     correction, 5.26  
 surface wash pumps, water  
     treatment plants, 9.19  
 surface water pumps, 9.3  
 surge chambers, 12.12  
 surge control, sewage systems, 9.41  
 surge legs, solids pumps,  
     9.374, 9.376  
 surge protection, piping, 10.31  
 surge suppressors,  
     waterhammer, 8.100  
 surge tanks  
     pumped storage, 9.271  
     waterhammer prevention,  
         8.102–8.103  
 suspended solids, 5.19  
 swirl, 10.42  
 synchronous motors, 6.6  
     direct-connected exciters, 6.7  
     motor-generated exciters, 6.7  
     static excitation, 6.7  
 system design, mining pumps, 9.205  
 system-head curves  
     pumping systems, 8.13  
     water supply systems, 9.10

## T

tandem seals, 2.209  
 tank-cleaning marine pumps, 9.249  
 tanks, water pressure booster  
     systems, 9.456  
 tare of water consumption, 9.5  
 technical bid evaluations, 11.25  
 technical purchase  
     recommendations, 11.29  
 technical specifications,  
     RFQs, 11.9–11.10  
 telemetry pump control systems, 7.9  
 temper annealing, 5.6  
 temperature issues  
     fluids, rotary pumps, 3.135  
     packings, 2.192  
     pumping system flow rates, 8.77  
     rise, centrifugal pumps, 2.372  
     solutions, 9.114  
 test models, suction pits, 10.22  
 testing checklists, RFQs, 11.17  
 testing pumps, 13.2  
     accuracy, 13.8  
     cavitation, 13.10  
     Cipoletti weirs, 13.19, 13.22  
     current meters, 13.26  
     data recording, 13.38  
     differential pressure meters, 13.15  
     discharge measurement, 13.14  
     flow nozzles, 13.16  
     flumes, 13.23–13.24  
     head area meters, 13.18  
     head measurements, 13.27–13.28  
         bourdon gages, 13.35  
         differential mercury gages, 13.34  
         mercury gages, 13.34  
         water gages, 13.33  
     instrumentation, 13.8  
     operating conditions, 13.8–13.9  
     orifice meters, 13.17  
     pitot tubes, 13.18  
     pitot static tubes, 13.18  
     power measurements, 13.35  
     pressure transducers, 13.18  
     quantity meters, 13.14  
     rate of flow meters, 13.15  
     recommended procedure,  
         13.12–13.13  
     seismic nuclear pumps, 9.309  
     speed, 13.37–13.38  
     speed measurements, 13.36  
     tolerances, 13.8  
     V notch weirs, 13.23  
     venturi meters, 13.15  
     volumetric meters, 13.14  
     weighing meters, 13.14  
     weirs, 13.19, 13.22  
 TEWAC electric motors  
     (totally enclosed  
     water-to-air-cooled), 6.113  
 thermal issues  
     displacement pumps, 3.72  
     low flow rates, 2.438

- thermoplastic composite pumps, 5.51
- thermoset composite pumps, 5.52
- thixotropic liquids, 8.33, 9.188
- thoma cavitation parameter,
  - centrifugal pumps, 2.352
- three-body wear, 5.16, 5.18
- throat bushings, axially split casings, 2.141
- throat inlets, L/JL pumps, 4.15
- throttle bushings, 2.191
- throttle control, direct-acting pumps, 3.75
- throttling orifices, head losses, 8.77
- through hardening gears, 6.149
- thrust balance, canned motor pumps, 2.319–2.321
- thrust bearings, 2.149–2.150
- tidal river water, salinity, 5.37
- tilted pad bearings, 2.256, 2.259
- time history analysis, seismic nuclear pumps, 9.307
- time history of acceleration, seismic nuclear pumps, 9.307
- timed rotary pumps, 3.124
- timed rotor screw pumps, 3.103, 3.106–3.107
- Tirastat II controllers, wound-rotor induction controllers, 6.116
- tolerance
  - testing pumps, 13.8
  - wearing rings, 2.123–2.124
- torque
  - centrifugal pumps, 2.359–2.360
  - high-energy pumps, 2.72–2.73
  - hydraulic turbines, 6.86
  - oil well pumps, 9.382
  - power pumps, 3.8
  - variable frequency drives, 3.9
- torsional stress, shafts, 6.186
- tortuous-path precipitators, gas turbines, 6.94
- total dynamic head, centrifugal pumps, 2.10
- total head, 13.4
  - branch-line pumping systems, 8.90
  - pumping systems, 8.6–8.9
- total suction head
  - drainage pumps, 9.52
  - irrigation pumps, 9.52
- total suction lift
  - drainage pumps, 9.52
  - irrigation pumps, 9.52
- totally enclosed enclosures, electric motors, 6.16
- touchdown bearings. *See* catcher bearings.
- transducers, pump control systems, 7.7
- transfer function, magnetic bearings, 2.283
- transfer systems, agriculture, 9.441–9.442
- transient loads, magnetic bearings, 2.283
- transient operation, centrifugal pumps, 2.379–2.381
- transient power failures, centrifugal pumps, 2.376
- transient speeds, pumped storage, 9.263–9.264
- transmission systems, 6.175–6.176, 6.191–6.192
- transmittal torque, sealless magnetic drive pumps, 2.303
- transmitters, control systems, 7.7
- trashracks, 10.14–10.16
- treatment sewage systems, 9.26–9.27
- tribology, 5.14
- troubleshooting
  - axial thrust, 2.401
  - cavitation, 2.397
  - centrifugal pumps, 12.20, 12.22–12.23
  - displacement pumps, 3.63
  - gear units, 6.161–6.164
  - pressure pulsations, 2.403
  - radial thrust, 2.402
  - reciprocating pumps, 12.24
  - recirculation, 2.398
  - rotary pumps, 12.23
  - steam pumps, 12.25

TRS (test response spectrum),  
     seismic nuclear pumps, 9.307  
 true liquids, 8.33  
 tube turbines, 6.80  
 tubing shrink, oil well pumps, 9.385  
 tubular diaphragm pumps, 3.91  
 tuning magnetic bearings, 2.291  
 turbine chemical pumps, 9.121  
 turbine drainage pumps, 9.52  
 turbine irrigation pumps, 9.52  
 turbines  
     adjustable blade propeller, 6.79  
     affinity laws, 6.84  
     cavitation, 6.83  
     centrifugal pump applications,  
         2.385–2.387  
     choosing type, 6.86  
     fixed blade propeller, 6.79  
     Francis, 6.79  
     power shafts, 6.80  
     gas, 6.89  
         Brayton cycle, 6.89  
         Joule cycle, 6.89  
     horizontal shafts, 6.80  
     hydraulic, 6.78–6.79  
         flow units, 6.80  
         power shafts, 6.80  
         torque, 6.86  
     impulse, 6.79  
     inclined shaft, 6.80  
     inpulse, 6.78  
     power recovery, 6.83  
     runners, 6.79  
     sigma, 6.83  
     speed characteristic, 6.86  
     steam turbines, 6.37  
     tube, 6.80  
     vertical propeller, 6.80  
 turbopumps, space shuttle booster  
     pumps, 9.434  
 turbulence, journal bearings, 2.252  
 turbulent flow, 8.32, 9.327  
 turndown, fluid couplings, 6.136  
 turning vanes, suction pits, 10.13  
 twin volute pumps, 2.101

two-body wear, 5.16  
 two-chamber primers, 2.457  
 types of wear, 5.13

## U

unbalanced impellers, 2.432–2.433  
 unbalanced power pumps, 3.18–3.19  
 unbalanced seals, 2.201, 2.211  
 unbalanced valves, duplex steam  
     pumps, 3.43  
 underfiling vanes, centrifugal  
     pumps, 2.343  
 underwater vortexing, 10.22  
 uniform corrosion, chemical  
     pumps, 9.118  
 unit load capabilities, magnetic  
     bearings, 2.284  
 units of measure  
     discharge head, 13.4  
     efficiencies, 13.7  
     flooded suction, 13.3  
     head, 13.3  
     NPSH, 13.5  
     suction head, 13.3  
     total head, 13.4  
     total suction lift, 13.3  
     velocity head, 13.3  
     volume, 13.3  
     water power, 13.6  
 unloader mechanisms, displacement  
     pump suction valves, 3.77  
 unstable characteristic, 2.334  
 untimed arrangement, rotary  
     pumps, 3.124  
 untimed rotor screw pumps, 3.103,  
     3.107–3.108  
 USCS (U.S. Customary  
     System), 2.327  
 user interfaces, magnetic  
     bearings, 2.292  
 UV exposure, composite pumps, 5.50

## V

- V belts, adjustable-speed belt drives, 6.170
- V notch weirs, 13.23
- vacuum primers, 2.458
- valve covers, power pumps, 3.28
- valve dynamics, power pumps, 3.14
- valve friction, power pumps, 3.14
- valve springs, power pumps, 3.16
- valve-throttling constant speed control systems, 7.10
- valves
  - control systems, 7.14–7.15
  - control valves, 7.15
  - controlled closure, waterhammer prevention, 8.100
  - drainage pumps, 9.48
  - duplex steam pumps, 3.42–3.44
  - flow coefficients, 8.56–8.58, 8.62–8.63
  - frictional losses, 8.54
  - irrigation pumps, 9.48
  - liquid ends, steam pumps, 3.52
  - power pumps, 3.12–3.13, 3.15, 3.27
  - sewage systems, 9.41
  - simplex steam pumps, 3.45
  - solids pumps, 9.371–9.372
- vane pumps, 3.123
  - capacity, 3.140
  - rigid, 3.126
- vane tips
  - centrifugal pumps
    - clearance, 2.337
    - reducing size, 2.342
  - erosion, 5.12
- vaned diffusers, centrifugal pumps, 2.43–2.44
- vanes
  - high-energy pumps, blade combinations, 2.76–2.77
  - impellers, single-curvature, 2.113
- vapor lock, aircraft fuel pumps, 9.419
- vapor phase cooling systems, engines, 6.68
- vapor pressure
  - rotary pumps, 3.138
  - screw pumps, 3.110
- variable frequency drives, torque, 3.9
- variable orifices, bypass systems, 2.448
- variable speed drive water pressure booster systems, 9.449–9.452
- variable speed water supply systems, 9.14
- variable static head, pumping systems, 8.15
- variable system resistance, pumping systems, 8.16
- variable-displacement piston hydraulic pumps, variable water flow, 6.196
- variable-speed drivers, sewage systems, 9.40
- variable-torque loads, eddy current couplings, 6.101
- velocity caps, intakes, 10.18
- velocity diagrams, centrifugal pumps, 2.13, 2.19
- velocity head
  - centrifugal pumps, 2.10
  - pumping systems, 8.5
  - units of measure, 13.3
- velocity sensors, 2.421–2.424
- velocity-compounded single-stage steam turbines, 6.46
- Vena Contracta, 7.23, 2.448
- vendor clarification meetings, 11.25
- vendor data requirement forms, RFQs, 11.17
- vents
  - pipng systems, 12.11
  - valves, 2.460
- Venturi meters, 13.15
- Venturi tubes, 2.449
- vertical condensate pumps, 9.96
- vertical dry-pit pumps, 2.158–2.160
- vertical eddy current couplings, 6.104
- vertical flows, slurries, 9.341
- vertical operations, couplings, 6.182
- vertical propeller pumps, 2.166–2.167
- vertical propeller turbines, 6.80

- vertical pumps
    - axial thrust, 2.171, 2.172
    - foundation loads, 2.175
    - shaft elongation, 2.175
    - support systems, 2.163
  - vertical sewage pumps, 2.158
  - vertical shaft pumps, 2.99, 2.328
  - vertical single-suction pumps, 2.160–2.162
  - vertical turbine pumps, 2.97, 2.163
    - impellers, 2.165
    - suction case, 2.164
  - vertical wet pit pumps, 2.163, 2.170, 12.3
  - vertically split casings, 2.102
  - vibration
    - centrifugal pumps, 2.382
    - piping, 10.31
  - vibration analysis, 2.419–2.424
    - antifriction bearings, 2.434
    - baseplates, 2.435
    - impellers, 2.432
    - symptom diagnosis, 2.425, 2.430–2.431
  - vibration isolation, engines, 6.74
  - viscosity
    - bearing performance, 2.258
    - centrifugal pumps, 2.25
    - drag losses, journal bearings, 2.253
    - food/beverage pump liquids, 9.188
    - heat generation, cylindrical bearings, 2.254
    - petroleum pump liquids, 9.150–9.154
    - rotary pumps, 3.132, 3.135
      - power losses, 3.145
    - screw pumps, 3.113
  - voltage ratings, electric motors, 6.22
  - volume
    - displacement flow control, 3.76
    - flow rate. *See* flow rate.
    - units of measure, 13.3
  - volumetric efficiency
    - centrifugal pumps, 2.50, 2.334
    - power pumps, 3.6–3.7
    - rotary pumps, 3.146, 3.149
  - volumetric meters, 13.14
  - volute pumps, 2.97, 2.168
    - cellar drainers, 2.169
    - drainage pumps, 9.46, 9.52
    - irrigation pumps, 9.46, 9.52
  - volute-casing pumps, 2.99
  - volute, centrifugal pumps, 2.41–2.43, 2.67
  - vortex pumps, 2.389
  - vortices
    - correcting, 10.52
    - free surface, 10.39
    - subsurface, 10.40
    - suction pits, 10.22–10.23
- ## W
- walking beams, mechanically driven
    - diaphragm pumps, 3.87
  - warm-up flow piping, 12.11
  - wash liquors, paper mill pumps, 9.165
  - wash water pumps, water treatment plants, 9.18
  - waste heat marine pumps, 9.231
  - waste pumps, 9.321
  - waste treatment. *See* sewage systems.
  - water as bearing lubricant, 2.152
  - water column separation, waterhammer, 8.100
  - water consumption rates, water supply systems, 9.6
  - water distillation marine pumps, 9.234
  - water flooding of oil fields, gas turbines, 6.95
  - water flushed wearing rings, 2.119
  - water gages, measuring head, 13.33
  - water horsepower, steam pumps, 3.59
  - water injection pumps, 9.148, 9.150
  - water power, units of measure, 13.6
  - water pressure booster systems, 9.447

- constant speed multipump, 9.454
- control panels, 9.455
- demand profiles, 9.457–9.460
- limited storage constant speed
  - multipump, 9.456
- materials of construction, 9.461
- sizing tanks, 9.456
- variable speed drives, 9.449–9.452
- water supply systems
  - abrasiveness, 9.9
  - alkalinity, 9.9
  - capacities, 9.6
  - consumption rates, 9.6
  - demand fluctuations, 9.5
  - drivers, 9.10
  - frictional losses, 9.12
  - NPSH, 9.12
  - parallel/series operation, 9.13–9.14
  - pressure differential, 9.12
  - pumping time variations, 9.6
  - static head, 9.12
  - suction/discharge piping, 9.9
  - system-head curves, 9.10
  - variable speed units, 9.14
- water treatment plants, 9.15
  - booster pumps, 9.19
  - carbon slurry pumps, 9.17
  - coagulant feed pumps, 9.16
  - fluoride pumps, 9.17
  - high-service pumps, 9.19
  - low lift pumps, 9.16
  - plant water pumps, 9.18
  - sampling pumps, 9.18
  - surface wash pumps, 9.19
  - wash water pumps, 9.18
- water-cooled eddy current couplings,
  - enclosures, 6.105
- water-cooled stuffing boxes, 2.145
- water-jet exhausters, 4.41
- water-sealing tanks, sewage
  - pumps, 2.144
- waterhammer, 8.91
  - air chambers, 8.101, 8.103
  - basic assumptions, 8.92
  - check valves, 8.98, 8.102
  - control devices, 8.103, 8.105
  - controlled valve closure, 8.100
  - controlled valve opening, 8.102
  - discharge line profiles, 8.93
  - flywheel effect, 8.94
  - high head systems, 8.93
  - low head systems, 8.93
  - mining pumps, 9.208
  - nonreverse ratchets, 8.102
  - pipeline sizes, 8.94
  - pump motor failure, 8.95–8.96
  - quick opening slow closing
    - valves, 8.101
  - reducing effects, 8.93, 8.95
  - rigid water column theory, 8.93
  - solving problem, 8.95
  - specific pump speed, 8.94
  - surge suppressors, 8.100
  - surge tanks, 8.102–8.103
  - water column separation, 8.100
  - wave velocity, 8.93
- waterwheels, 1.2
- wave velocity, waterhammer, 8.93
- wear, 5.13
  - abrasive wear, 5.16, 5.18
  - adhesive wear, 5.14
  - slurry pumps, 9.353, 9.363, 9.365
- wearing rings, 2.118, 5.30
  - axial clearance, 2.121
  - axial thrust, 2.125
  - clearances, 2.123–2.124, 2.336
  - dam-type, 2.120
  - flat, 2.119
  - inspection ports, 2.120
  - L-type, 2.119
  - labyrinth, 2.119
  - mounting, 2.122
  - stationary, 2.122
  - step, 2.119
  - tolerance, 2.123–2.124
  - water flushed, 2.119
- wearing-ring hubs, 2.118
- weather protected enclosures,
  - electric motors, 6.16



weather-protected eddy current  
couplings, 6.105  
weighing meters, 13.14  
weirs, 13.19, 13.22  
weldments, chemical pumps, 9.121  
well pumps, 9.21–9.22  
well water pumps, 9.259  
wet pit once through intakes, 10.5  
wet pit raw sewage pumps, 9.29  
wet vacuum pumps, 2.458  
wet-pit pumps, 2.99  
whirl, bearings, 2.266  
whirl instability, cylindrical  
bearings, 2.254  
white liquor, paper mill  
pumps, 9.162  
wire mesh screens, head losses, 8.71  
wire-to-liquid efficiency, 2.329  
wire-to-water efficiency, 2.329  
wood-block transmissions, 6.171  
working barrel, power pumps, 3.22

worm gears, 6.148  
wound-rotor induction motors,  
6.5–6.6  
contact secondary controls, 6.116  
FVNR starters (full voltage  
nonreversing), 6.111  
liquid rheostat controls,  
6.112–6.113  
Tirastat II controllers, 6.116  
wrist pin bearings, power  
pumps, 3.33  
wrist pins, power pumps, 3.31

## Z

zero-bevel gears, 6.147  
ZPA (zero period acceleration),  
seismic nuclear pumps, 9.307